

# AgriMetal

## PARTS LIST

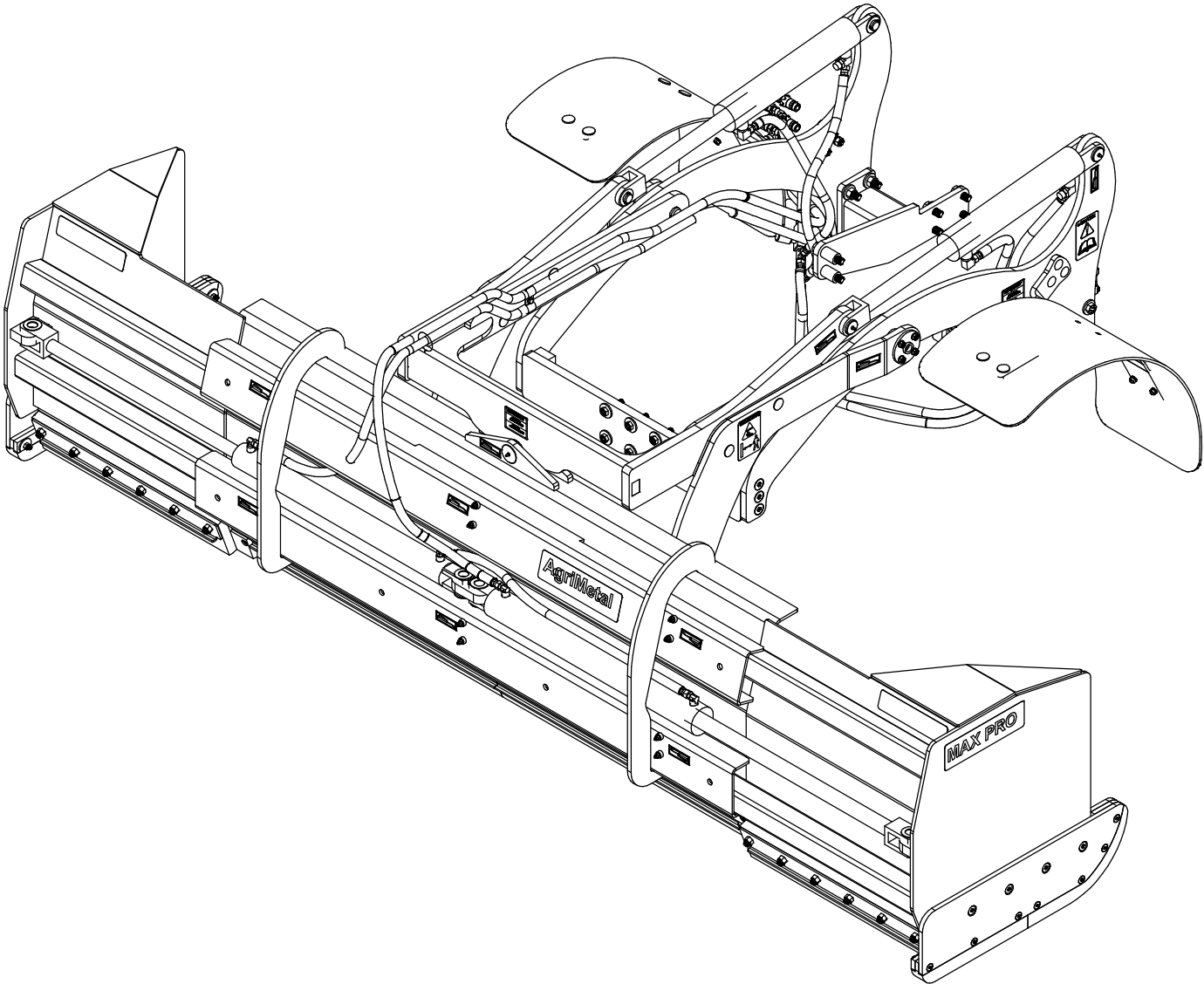

**MAX PRO 6-10 (MASSEY FERGUSON 1758)**

#	PART #	Qty	TITLE
1	92-42-0003	1	INSIDE RUBBER KNIFE (RIGHT)
2	92-42-0000	1	INSIDE RUBBER KNIFE (LEFT)
3	92-04-0021	1	KNIFE BRACE (RIGHT)
4	92-04-0024	1	KNIFE BRACE (LEFT)
5	91-20-0150	16	WASHER
6	NC01-96-0014	28	NYLON INSERT LOCKNUT 1/2-13"
7	NC02-48-0548	28	FLAT HEAD SOCKET CAP SCREW STAINLESS 1/2-13 X 2"
8	92-42-0121	2	SNOW GUARD
9	NC02-48-0582	4	FLAT HEAD SOCKET CAP SCREW STAINLESS 1/4-20 X 2"
10	NC01-96-0009	4	NYLON-INSERT LOCKNUT ZINC 1/4-20
11	92-42-0005	2	OUTSIDE RUBBER KNIFE
12	92-04-0016	2	KNIFE BRACE (OUTSIDE)

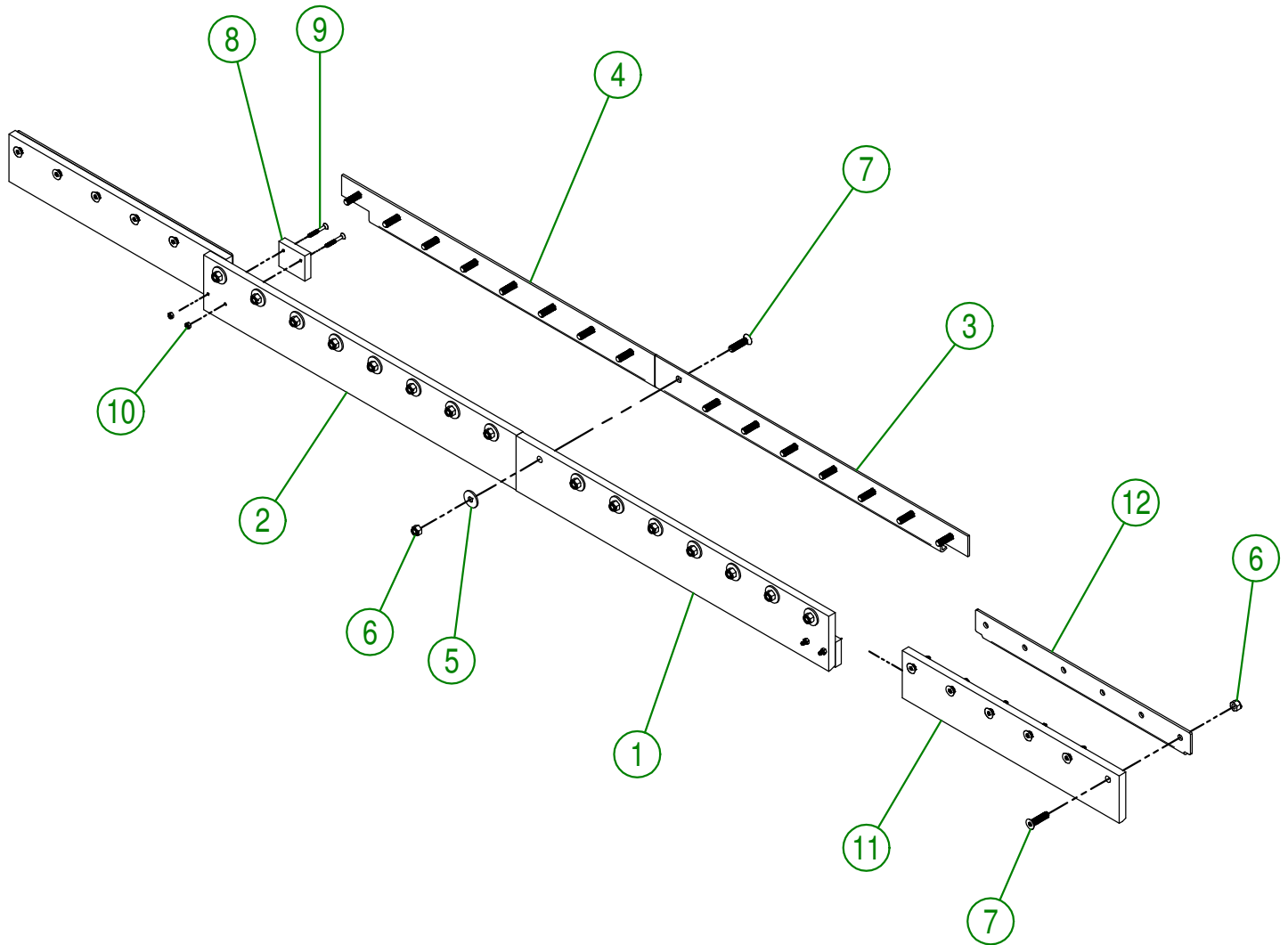

**AGRIMETAL**  
**RUBBER KNIFE GROUP**

CREATION : 09/05/17  
 REVISION : 07/08/18

ASSEMBLY : **92-57-0195**

AUTHOR : J. Houle

Page 1 de 12

#	PART #	Qty	TITLE
1	92-50-0051	1	RIGHT CENTER KNIFE
2	92-50-0056	1	LEFT CENTER KNIFE
3	NC01-96-0014	28	NYLON INSERT LOCKNUT 1/2-13"
4	NC02-48-0547	28	FLAT HEAD SOCKET CAP SCREW STAINLESS 1/2-13 X 1 3/4
5	92-20-0378	2	KNIFE

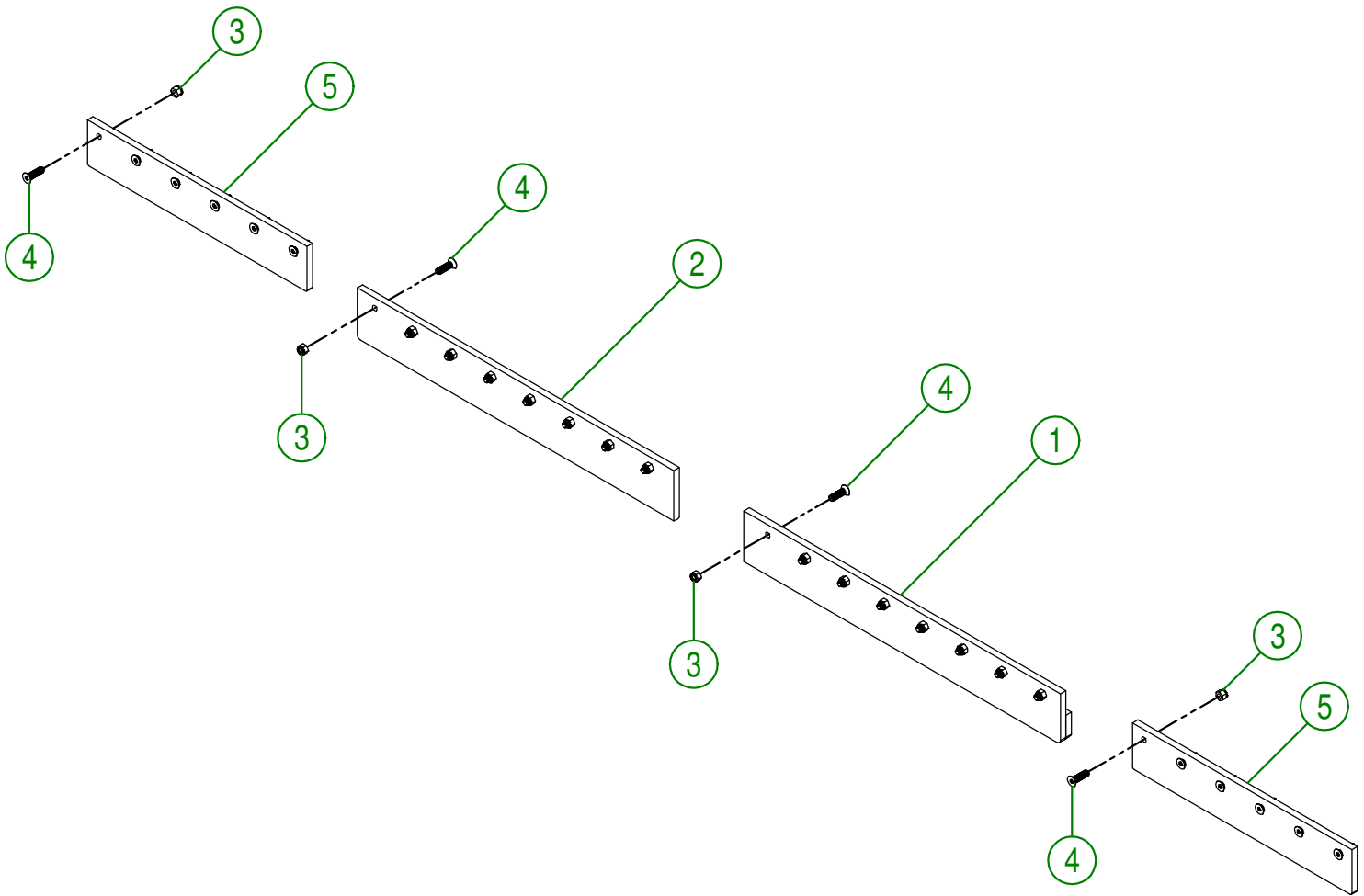

<b>AGRIMETAL</b>	
<b>QT KNIFE GROUP</b>	
CREATION : 10/08/16	ASSEMBLY : 92-57-0200
REVISION : 29/12/17	AUTHOR : Production Page 2 de 12

#	PART #	Qty	TITLE
1	92-42-0132	1	KNIFE (U.H.M.W)
2	92-42-0130	1	KNIFE (U.H.M.W)
3	92-04-0021	1	KNIFE BRACE (RIGHT)
4	92-04-0024	1	KNIFE BRACE (LEFT)
5	91-20-0150	16	WASHER
6	NC01-96-0014	28	NYLON INSERT LOCKNUT 1/2-13"
7	NC02-48-0549	28	STAINLESS FLAT HEAD SOCKET CAP SCREW 1/2-13 X 2 1/4"
8	92-42-0120	2	SNOW GUARD
9	NC02-48-0582	4	FLAT HEAD SOCKET CAP SCREW STAINLESS 1/4-20 X 2"
10	NC01-96-0009	4	NYLON-INSERT LOCKNUT ZINC 1/4-20
11	92-42-0148	2	KNIFE (U.H.M.W)
12	92-04-0016	2	KNIFE BRACE (OUTSIDE)

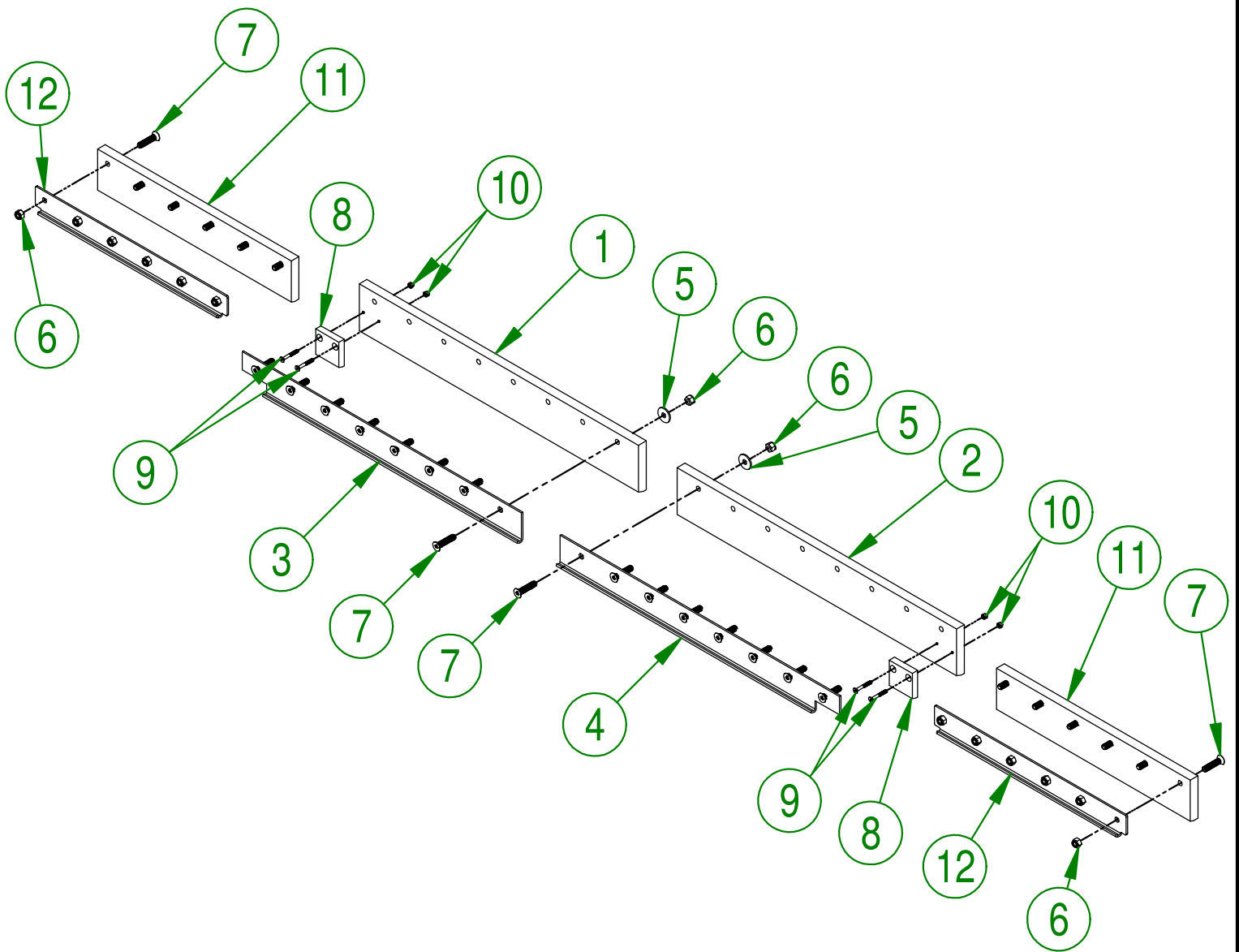

<b>AGRIMETAL</b>	
<b>UHMW KNIFE GROUP</b>	
CREATION : 10/08/16	ASSEMBLY : 92-57-0205
REVISION : 15/11/18	AUTHOR : Production Page 3 de 12

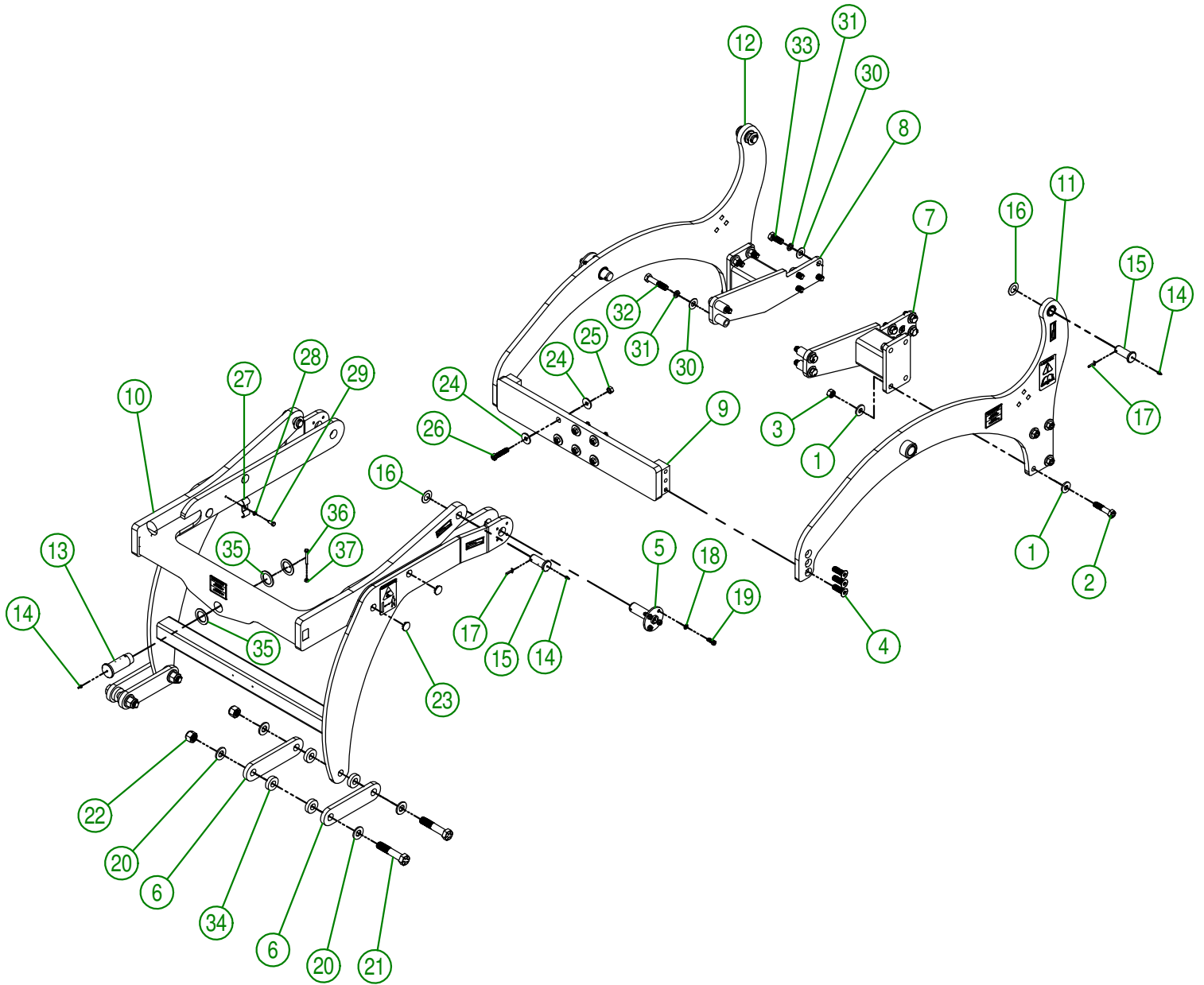

**AGRIMETAL**  
**SUBFRAME GROUP**

CREATION : 23/01/17  
 REVISION : 14/02/19

ASSEMBLY : **91-57-0325**

AUTHOR : J. HOULE

Page 4 de 12

#	PART #	Qty	TITLE
1	91-20-0155	16	FLAT WASHER
2	NC01-33-0400	8	CAP SCREW GR8 NC ZINC 5/8-11 X 3" LG
3	NC01-94-0100	8	STAINLESS DISTORTED THREAD LOCKNUT
4	NC02-48-0562	6	FLAT HEAD SOCKET CAP SCREW STAINLESS 5/8-11 X 1 1/2"
5	91-50-0030	2	SUBFRAME PIVOT
6	91-04-1420	4	BLADE CONNECTOR
7	91-50-0160	1	LEFT FRAME SUPPORT
8	91-50-0165	1	RIGHT FRAME SUPPORT
9	91-50-0170	1	FRAME SUPPORT
10	91-57-0330	1	SUBFRAME
11	91-57-0335	1	LEFT FRAME
12	91-57-0340	1	RIGHT FRAME
13	91-13-2800	1	CENTER PIVOT SHAFT
14	NC01-69-0785	7	STRAIGHT GREASE FITTING 1/4-28
15	91-20-0210	4	CYLINDER PIVOT
16	91-22-2200	4	FLAT WASHER HYDRAULIC CYLINDER
17	NC01-69-0159	4	COTTER PIN ZINC 3/16 X 1 1/2"
18	NC02-32-0012	8	LOCK WASHER ZINC 3/8"
19	NC01-37-0114	8	BOLT GR8 3/8" X 1"
20	09-04-0050	8	PNO 3/16" X 1 49/64" DIA. X Ø 7/8" FLAT WASHER
21	NC01-33-0506	4	CAP SCREW GR8 NC ZINC 7/8-9 X 4 1/2" LG
22	NC01-96-0018	4	NYLON INSERT NUT 7/8-9
23	NC13-80-0273	8	BLACK CAP 1" DIA
24	91-20-0150	12	WASHER
25	NC01-94-0013	6	NYLON NUT ZINC 1/2-20"
26	NC01-37-0252	6	HEX. BOLT HEX. GR8 ZINC 1/2-20 X 2 1/4"
27	91-01-0020	1	HYDRAULIC HOSE PROTECTOR
28	NC02-32-0011	1	LOCK WASHER ZINC 5/16"
29	NC01-17-0058	1	HEX. BOLT GR2 ZINC 5/16-18 X 3/4"
30	NC02-26-0100	12	WASHER STAINLESS 0.688 ID X 1.5 OD
31	NC02-32-0016	12	LOCK WASHER ZINC 5/8"
32	NC01-50-0113	4	HEX. BOLT GRI0.9 M16 X 1.5 X 80MM
33	NC01-50-0105	8	HEX. BOLT GRI0.9 M16 X 1.5 X 40MM
34	NC13-15-0319	8	RUBBER WASHER
35	92-01-0005	3	WASHER 2 1/4" DIA. X 1 9/16"
36	NC01-17-0010	1	HEX. BOLT GR2 NC ZINC 1/4-20 X 2"
37	NC01-93-0001	1	HEX. NUT NC ZINC 1/4-20

#	PART #	Qty	TITLE
1	92-57-0260	1	CENTRAL BLADE MAX PRO 6-10 INCLUDED STICKER GROUP.
2	NC01-69-0791	12	GREASE FITTING 1/8 NPT STRAIGHT

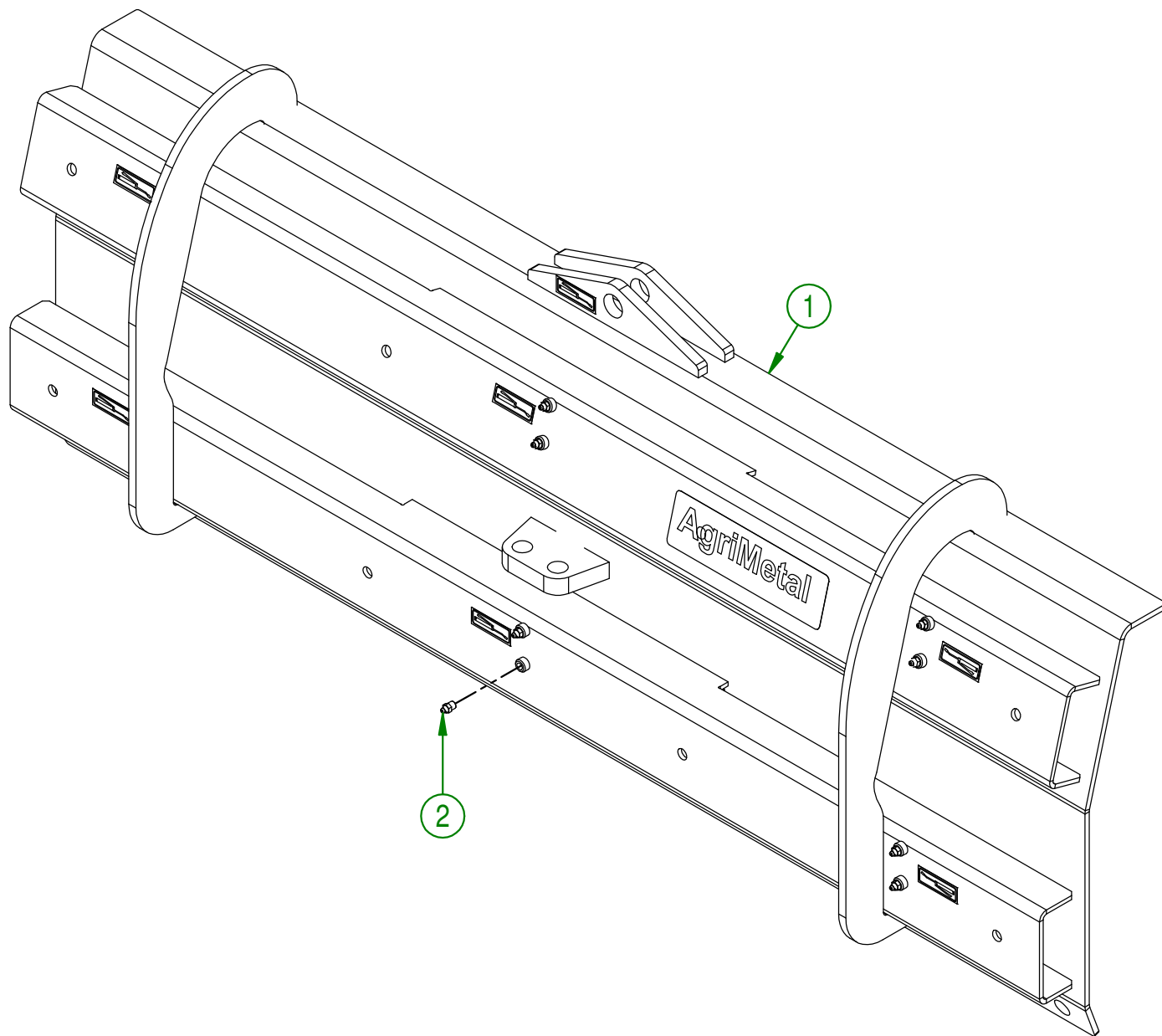

<b>AGRIMETAL</b>	
<b>CENTER BLADE</b>	
CREATION : 20/12/17	ASSEMBLY : <b>92-57-0040</b>
REVISION : 15/11/18	AUTHOR : J.KABWE   Page 6 de 12

#	PART #	Qty	TITLE
1	91-42-0144	1	FLOATING SKATE (RIGHT OUTSIDE)
2	NC13-15-0325	1	FLOATING SKATE (MIDDLE FRONT)
3	NC13-15-0323	1	FLOATING SKATE (MIDDLE BACK)
4	NC13-86-0052	2	SPRING 1/2" ID X 1" OD X 5" LG
5	91-42-0142	1	FLOATING SKATE (RIGHT INSIDE)
6	NC02-48-0549	4	STAINLESS FLAT HEAD SOCKET CAP SCREW 1/2-13 X 2 1/4"
7	NC02-48-0537	7	STAINLESS FLAT HEAD SOCKET CAP SCREW 3/8-16 X 2 1/4"
8	91-20-0163	2	WASHER
9	91-20-0150	4	WASHER
10	91-20-0160	5	WASHER
11	NC01-96-0011	7	NYLON NUT 3/8-16
12	NC01-96-0014	4	NYLON INSERT LOCKNUT 1/2-13"
13	91-09-0000	4	BUSHING
14	92-57-0265	1	RIGHT BLADE

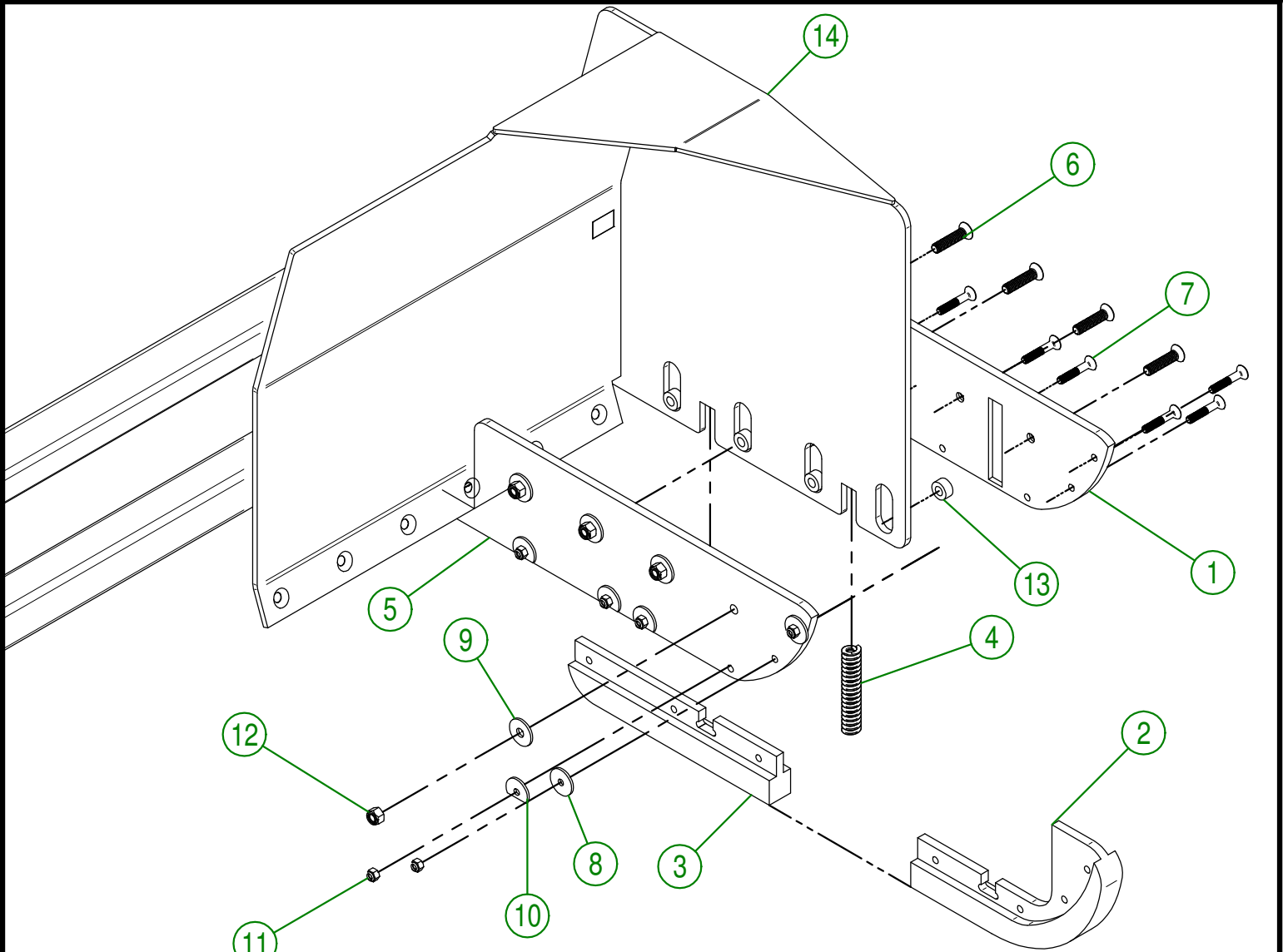

<b>AGRIMETAL</b>	
<b>RIGHT BLADE</b>	
CREATION : 10/08/16	ASSEMBLY : 92-57-0045
REVISION : 15/11/18	AUTHOR : JA. H Page 7 de 12



#	PART #	Qty	TITLE
1	91-42-0140	1	FLOATING SKATE (LEFT EXT.)
2	NC13-15-0325	1	FLOATING SKATE (MIDDLE FRONT)
3	NC13-15-0323	1	FLOATING SKATE (MIDDLE BACK)
4	NC13-86-0052	2	SPRING 1/2" ID X 1" OD X 5" LG
5	91-09-0000	4	BUSHING
6	91-42-0136	1	FLOATING SKATE (LEFT INT.)
7	NC02-48-0549	4	STAINLESS FLAT HEAD SOCKET CAP SCREW 1/2-13 X 2 1/4"
8	NC02-48-0537	7	STAINLESS FLAT HEAD SOCKET CAP SCREW 3/8-16 X 2 1/4"
9	91-20-0163	2	WASHER
10	91-20-0160	5	WASHER
11	91-20-0150	4	WASHER
12	NC01-96-0011	7	NYLON NUT 3/8-16
13	NC01-96-0014	4	NYLON INSERT LOCKNUT 1/2-13"
14	92-57-0270	1	LEFT BLADE

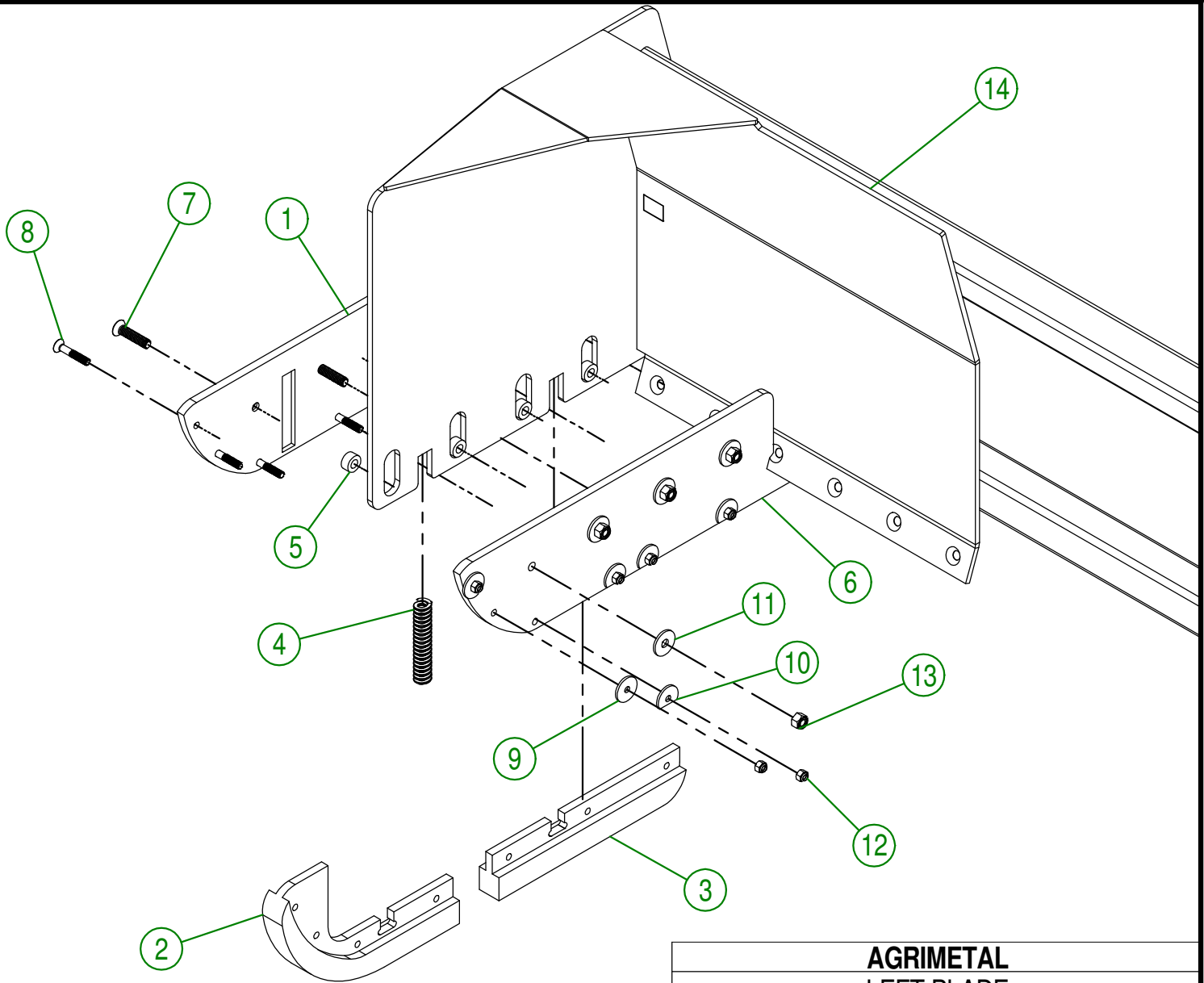

<b>AGRIMETAL</b>	
<b>LEFT BLADE</b>	
CREATION : 10/08/16	ASSEMBLY : 92-57-0050
REVISION : 15/11/18	AUTHOR : JA. H   Page 8 de 12

#	PART #	Qty	TITLE
1	91-50-0155	1	RIGHT MUDE GUARD BRACKET
2	NC01-54-0200	6	CARR. BOLT STAINLESS 1/2-13 X 2"
3	91-42-0155	2	MUD GUARD
4	NC01-13-0062	12	ELEVATOR STAINLESS BOLT 5/16-18 X 1"
5	NC02-22-0008	12	WASHER ZINC 5/16"
6	NC02-32-0011	12	LOCK WASHER ZINC 5/16"
7	NC02-07-0017	12	HEX. NUT 5/16-18
8	NC02-32-0100	6	LOCK WASHER STAINLESS 1/2"
9	NC02-14-0100	6	HEX NUT STAINLESS 1/2-13
10	91-50-0157	1	LEFT MUDE GUARD BRACKET

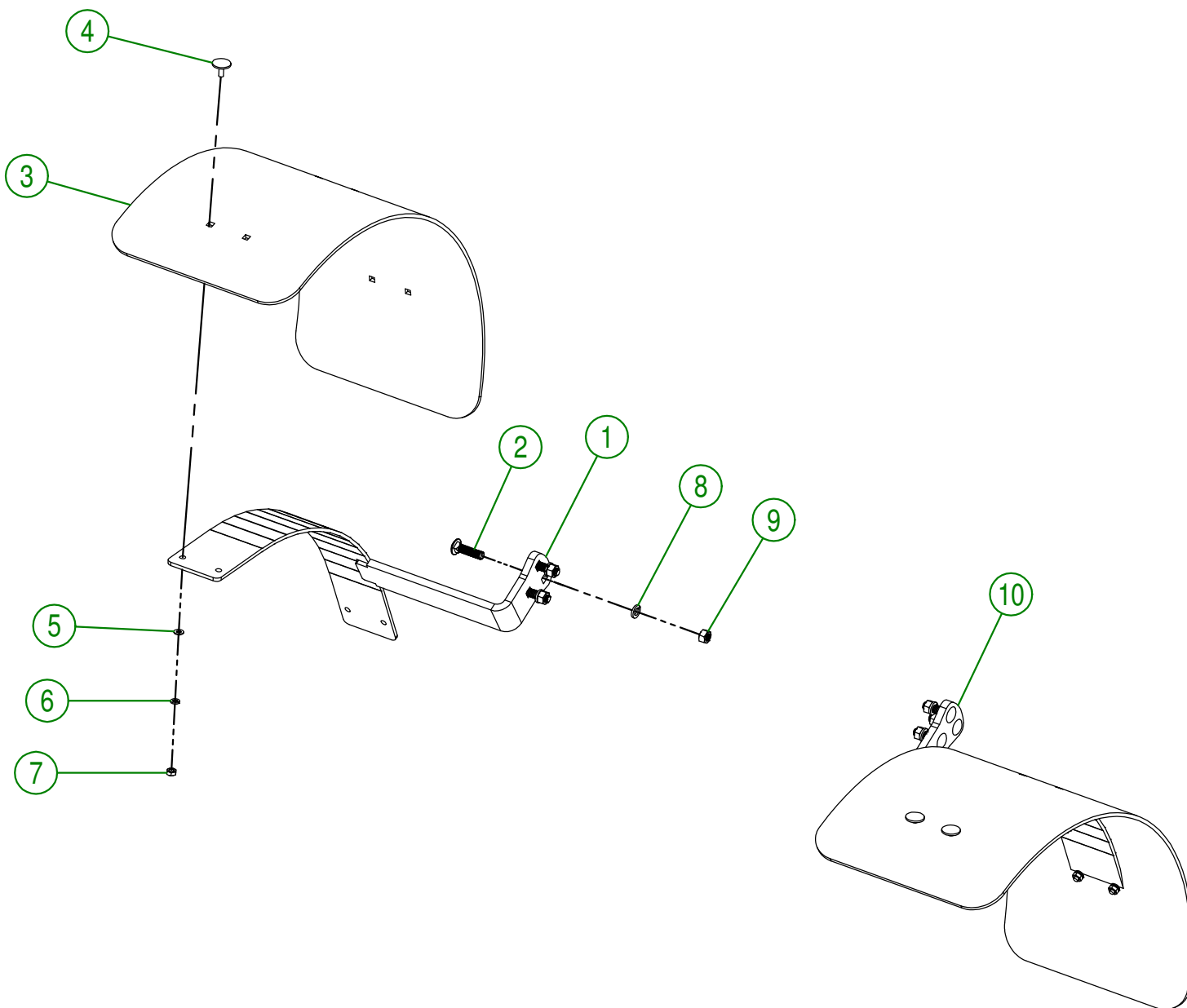

<b>AGRIMETAL</b>	
<b>MUD GUARD GROUP</b>	
CREATION : 23/01/17	ASSEMBLY : <b>91-57-0320</b>
REVISION : 19/01/18	AUTHOR : J. HOULE   Page 9 de 12

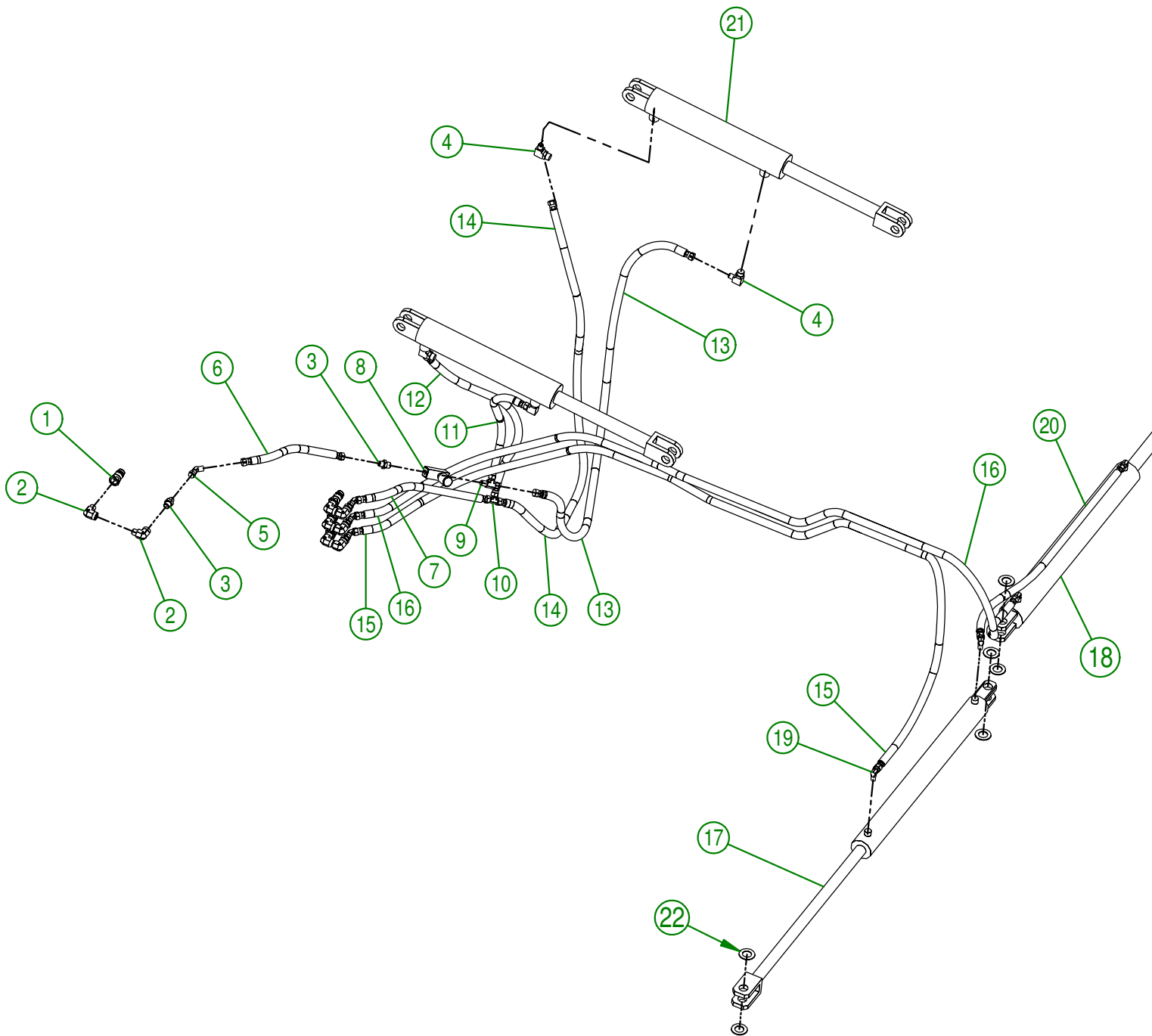

**AGRIMETAL**  
**HYDRAULIC GROUP**

CREATION : 23/01/17  
 REVISION : 14/02/19

ASSEMBLY : **91-57-0345**

AUTHOR : Dessin1 Page 10 de 12

#	PART #	Qty	TITLE
1	NC13-45-0285	4	QUICK COUPLER 3/8 NPTF
2	NC13-45-0038	8	ELBOW 90 3/8 FEM. NPT X 3/8 MALE NPT
3	NC13-45-0288	5	STRAIGHT FITTING 1/2" MALE JIC X 3/8" MALE NPT
4	NC13-45-0242	4	90 DEG ELBOW
5	NC13-45-0270	4	45 DEG ELBOW
6	NC17-02-0378	1	HYDRAULIC HOSE 10 1/2"
7	NC17-02-0379	1	HYDRAULIC HOSE 14 7/8"
8	NC13-45-0241	1	FLOW CONTROLE 3/8" NPT FEMALE
9	NC13-45-0244	1	TEE FITTING 3/8" MALE NPT X 3/8" MALE JIC X 3/8" MAL JIC
10	NC13-45-0289	1	T 3/8 MALE JIC X 3/8 MALE JIC X 3/8 MALE JIC
11	NC17-02-0381	1	HYDRAULIC HOSE 21 1/4"
12	NC17-02-0381	1	HYDRAULIC HOSE 21 1/4"
13	NC17-02-0370	1	HYDRAULIC HOSE 50"
14	NC17-02-0370	1	HYDRAULIC HOSE 50"
15	NC17-02-0383	1	HYDRAULIC HOSE 105"
16	NC17-02-0383	1	HYDRAULIC HOSE 105"
17	NC13-45-0238	1	HYDRAULIC CYLINDER 2" X 24" STROKE
18	NC13-45-0237	1	HYDRAULIC CYLINDER 2 1/2" X 24" STROKE
19	NC13-45-0254	4	90 DEG ELBOW 9/16"-18 MALE SAE6 O RING X 3/8" MALE JIC
20	NC17-02-0351	1	HYDRAULIC HOSE 34" LG
21	NC13-45-0257	2	HYDRAULIC CYLINDER 2 1/2" X 12" STROKE
22	91-22-2200	8	FLAT WASHER HYDRAULIC CYLINDER

#	PART #	Qty	TITLE
1	NCI3-33-0268	2	STICKER WARNING
2	NCI3-33-0024	14	STICKER GREASE HERE
3	NCI3-33-0319	3	STICKER IMPORTANT GREASE EVERY 5 HOURS
4	NCI3-33-0183	2	STICKER CAUTION OPERATION MANUAL
5	NCI3-33-0035	1	STICKER AGRIMETAL
6	NCI3-33-0265	2	STICKER MAX PRO
7	28-60-0050	2	STICKER SCOTCHLITE

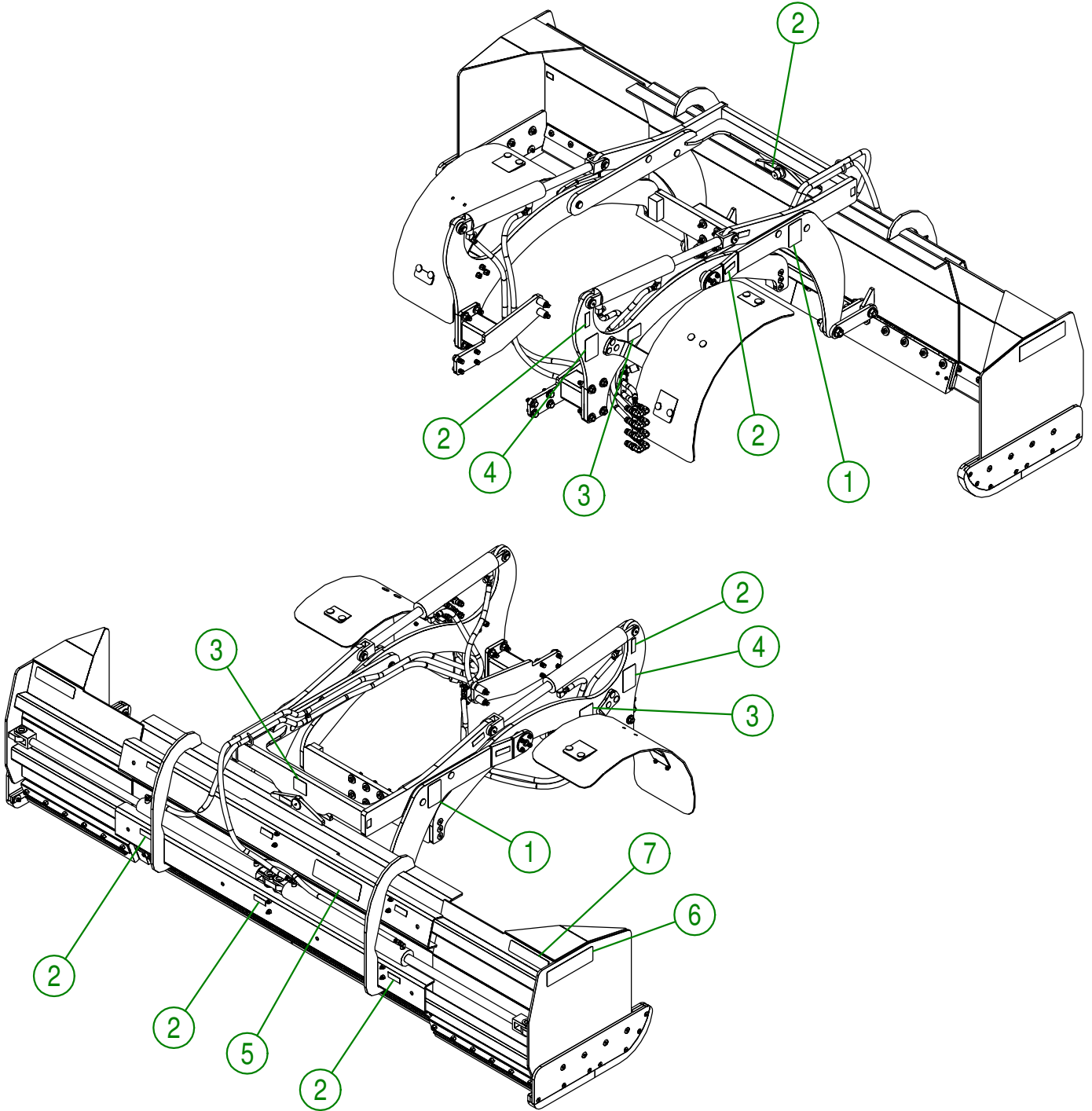

**AGRIMETAL**  
**MAX-PRO 6-10**

CREATION : 09/03/17  
REVISION : 14/02/19

ASSEMBLY : **91-99-2000**

AUTHOR : Production Page 12 de 12