

AgriMetal

PARTS LIST

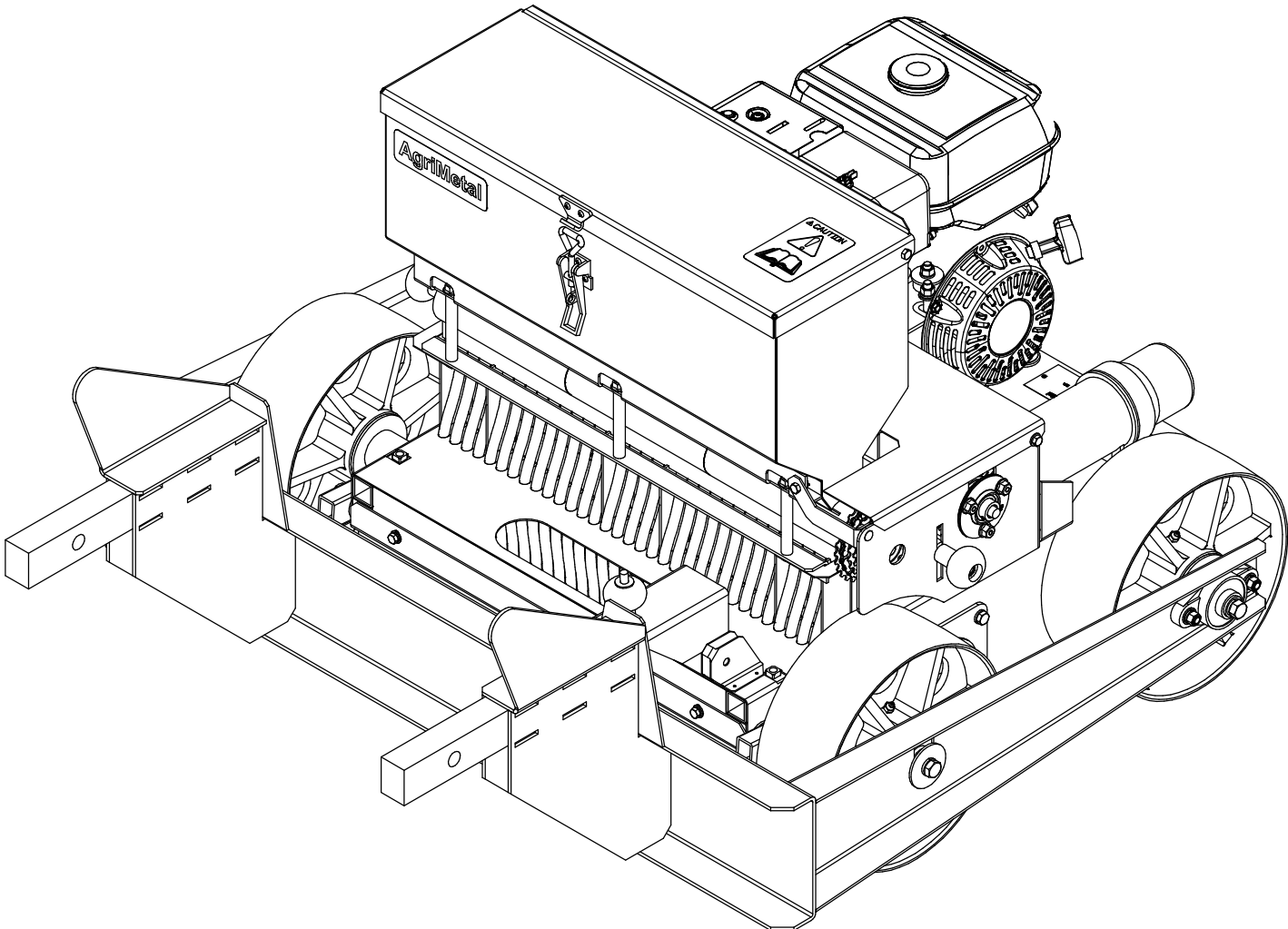

OVERSEEDER (JD-1500)

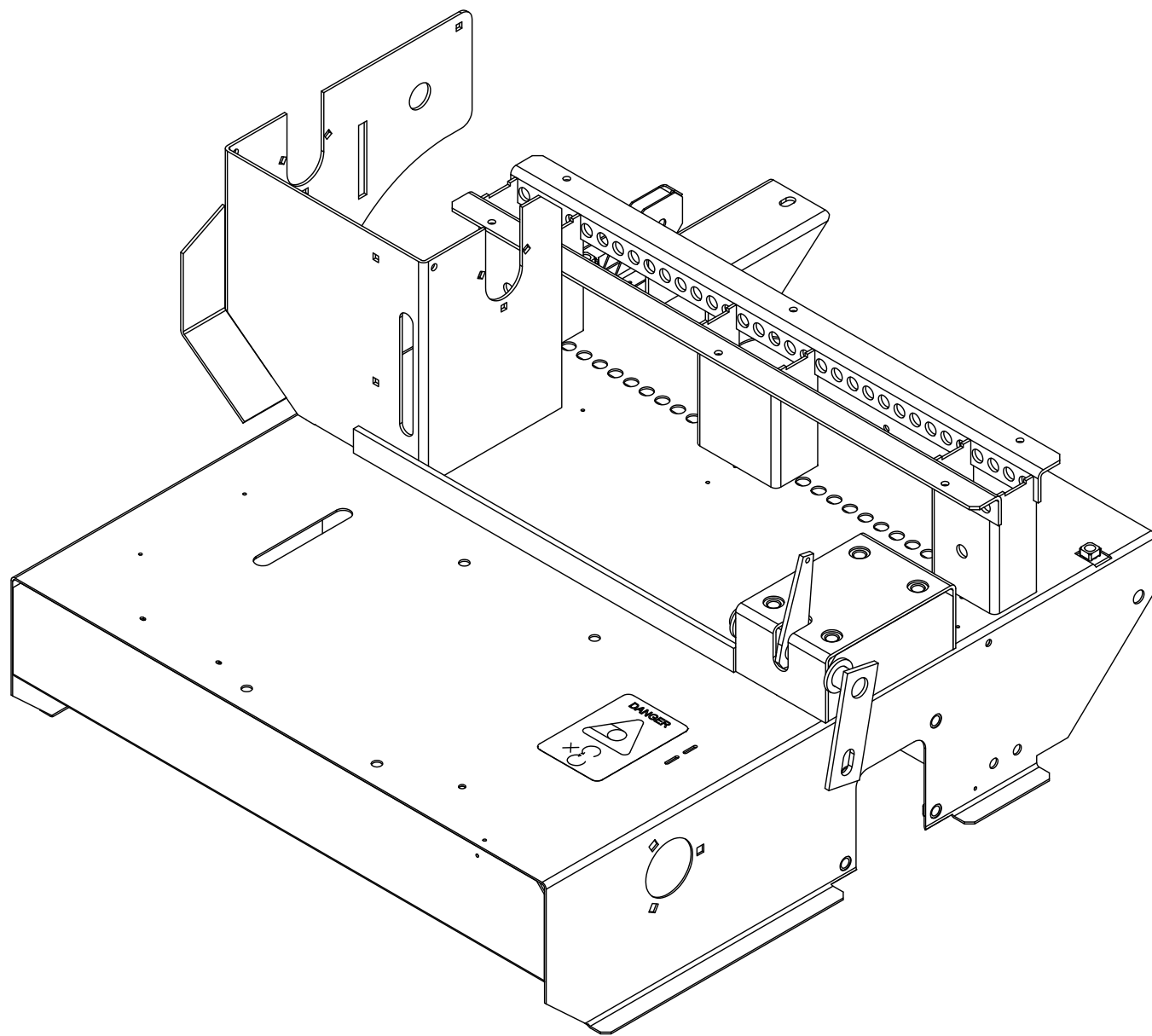

AGRIMETAL			
FRAME GROUP (STICKER INCLUDED)			
CREATION : 01/03/19	ASSEMBLY :	75-57-0000	
REVISION : 01/03/19	AUTHOR : F.HÉLIE	Page 1 de 28	

#	PART #	Qty	TITLE
1	75-42-0195	1	BRUSH 3/4" X 3/4" X 25 1/4" LG.
2	NC02-36-0136	8	FLAT HEAD MACHINE SCREW (SQUARE DRIVE) 1/4-20 X 1 1/4"
3	75-21-0200	34	SEED DISPENSER
4	75-42-0625	33	SEED DISPENSER WASHER
5	75-13-0405	1	SEED DISPENSER WHEEL ROD
6	75-13-0410	2	SEED DISPENSER ROD
7	01-01-2485	6	FLAT WASHER 14 GA X 13/16"OD X 25/64" ID
8	NC01-96-0011	6	NYLON NUT 3/8-16

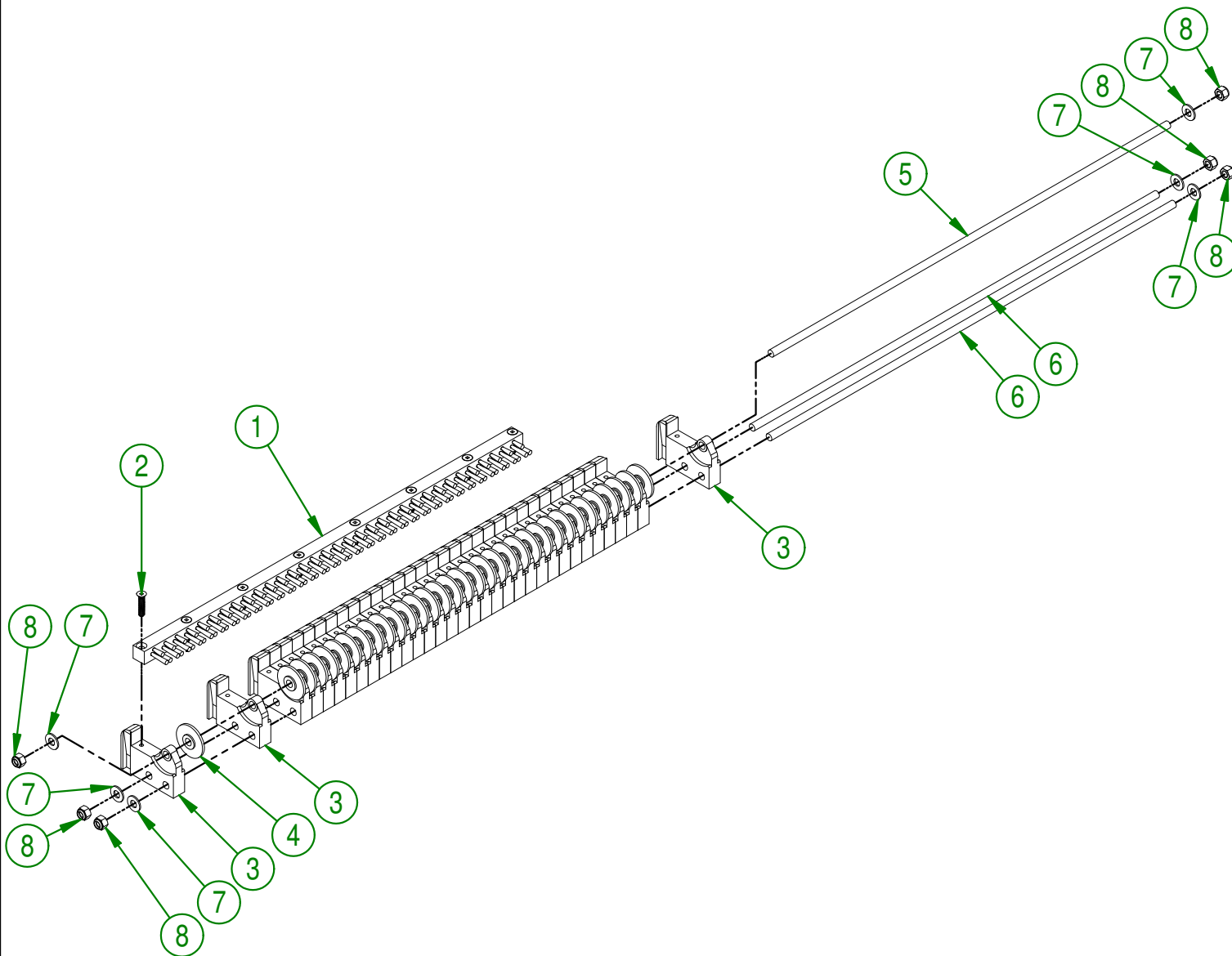

AGRIMETAL	
SEED DISPENSER ASSEMBLY	
CREATION : 01/03/19	ASSEMBLY : 75-55-0015
REVISION : 01/03/19	AUTHOR : F.HÉLIE Page 2 de 28

75-57-0010

#	PART #	Qty	TITLE
1	75-20-0105	1	FRONT WHEEL SHAFT
2	NC14-75-0009	4	PRESSED STEEL FLANGED HOUSING F5 O.D. 3 3/4"
3	NC14-75-0016	2	SEAL BALL BEARING SB 205-16
4	NC01-04-0055	6	CARR. BOLT GR2 ZINC 5/16-18 X 5/8"
5	NC02-14-0006	6	HEX. NUT SPECIAL FLANGET NC 5/16-18 B GRADE
6	NC01-65-0087	1	KEY 1/4 X 1/4 X 1 1/2"
7	NC14-55-0244	1	SPROCKET 35BI5H X Ø 1" KW 1/4" 2SS

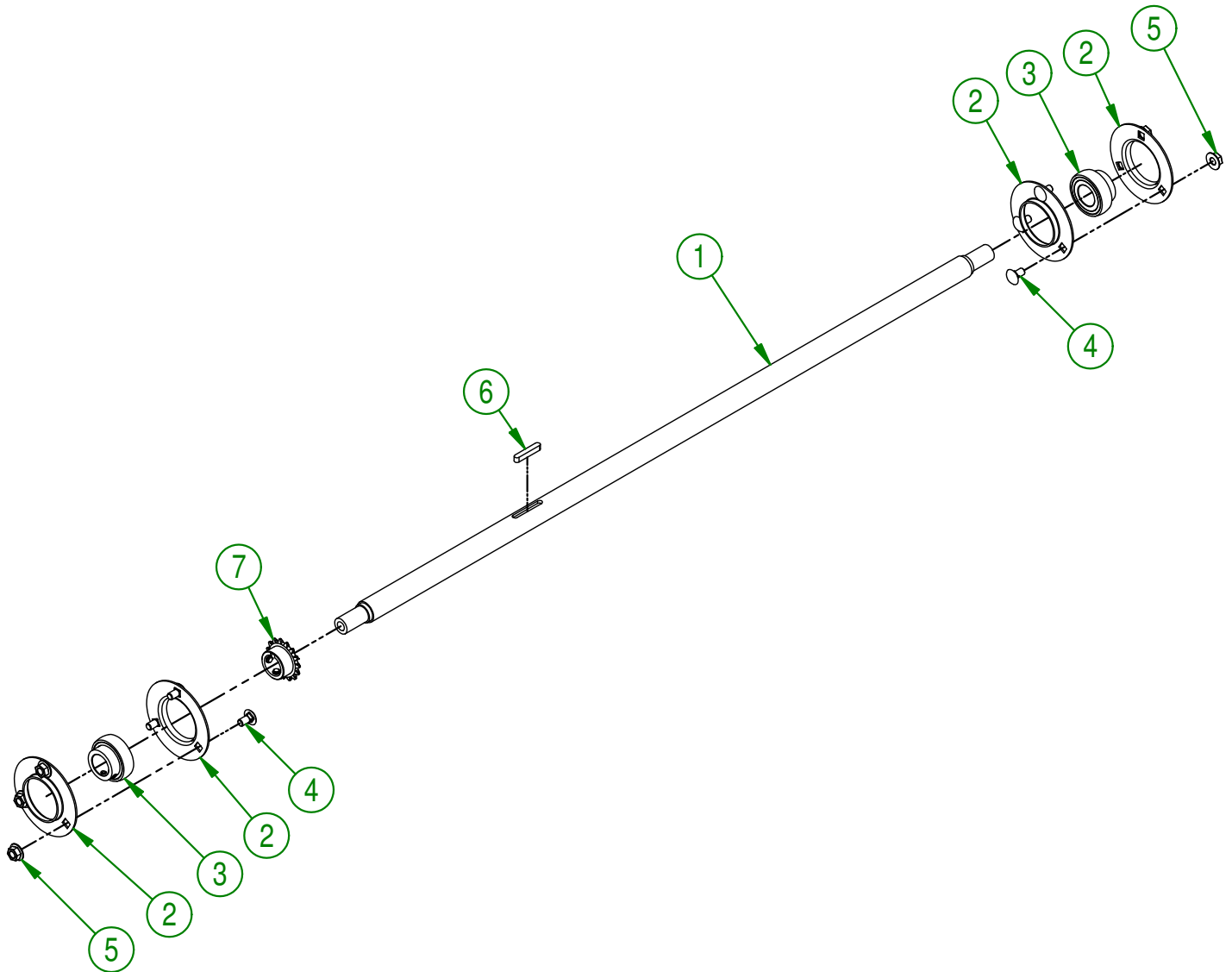

AGRIMETAL	
FRONT WHEEL SHAFT GROUP	
CREATION : 01/03/19	ASSEMBLY : 75-57-0010
REVISION : 01/03/19	AUTHOR : F.HÉLIE Page 3 de 28

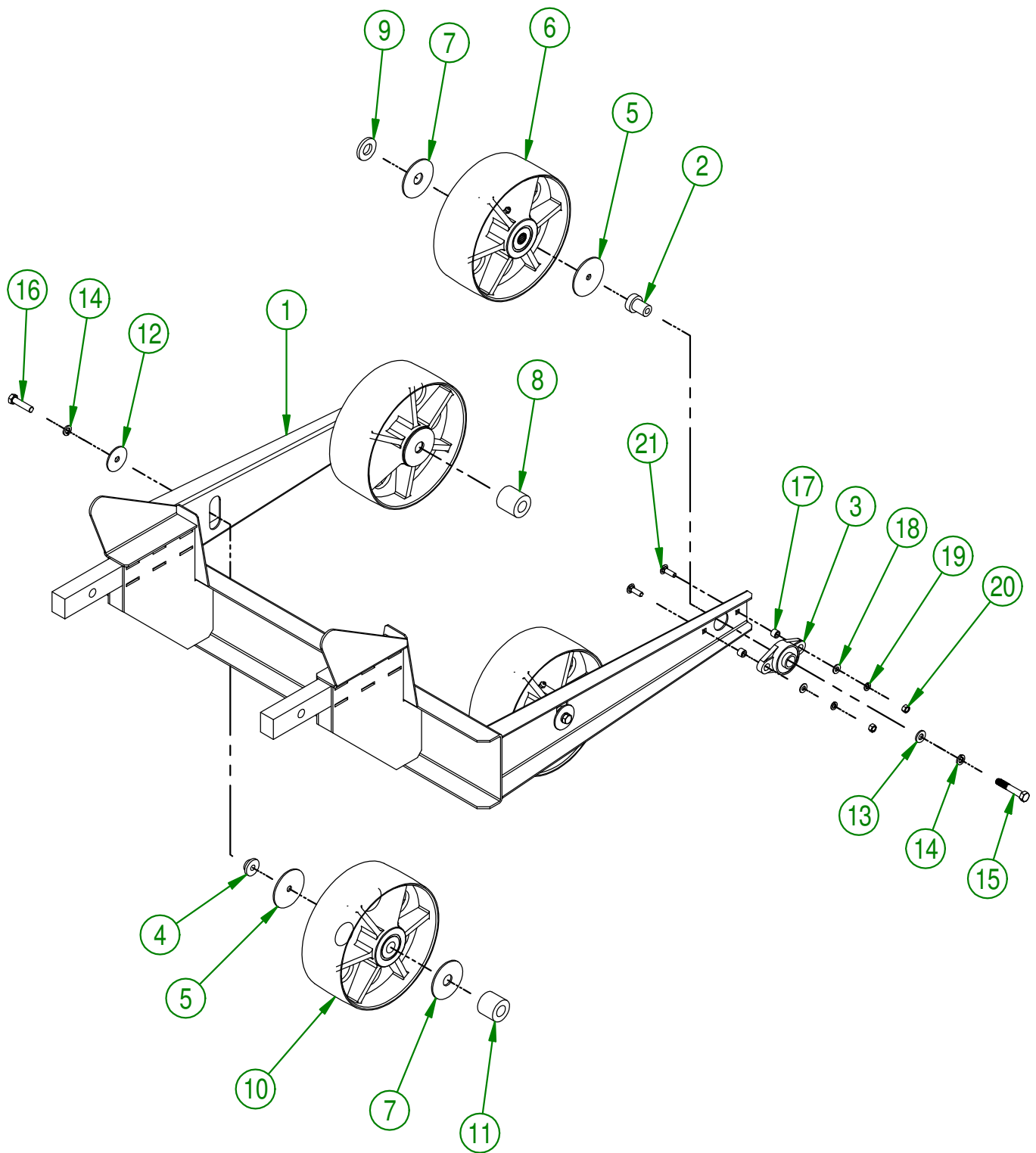

AGRIMETAL	
FRONT ATTACHMENT (JD-1500)	
CREATION : 20/04/20	ASSEMBLY : 75-57-0205
REVISION : 20/04/20	AUTHOR : J. Houle Page 4 de 28

#	PART #	Qty	TITLE
1	75-50-0250	1	FRONT ATTACHMENT
2	75-21-0025	2	FRONT ATTACHMENT BUSHING
3	NC14-75-0019	2	FLANGE PILLOW BLOCK BEARING UCFL205-16 Ø 1"
4	75-21-0030	2	FRONT ATTACHMENT BUSHING
5	75-01-0900	4	WASHER
6	75-55-0060	2	FRONT U.H.M.W. BLACK WHEEL
7	75-01-0902	4	WASHER
8	75-42-0140	1	LEFT FRONT WHEEL BUSHING
9	75-42-0150	1	RIGHT FRONT WHEEL WASHER
10	75-55-0055	2	REAR U.H.M.W BLACK WHEEL
11	75-42-0145	1	LEFT REAR WHEEL BUSHING
12	01-01-1625	2	FLAT WASHER
13	NC02-25-0011	2	WASHER SAE ZINC 17/32 ID
14	NC02-32-0014	4	LOCK WASHER ZINC 1/2"
15	NC01-17-0255	2	HEX. BOLT GR2 ZINC 1/2-13 X 3"
16	NC01-17-0251	2	HEX. BOLT GR2 ZINC 1/2-13 X 2"
17	32-09-0000	4	BUSHING BEARING
18	01-01-2485	4	FLAT WASHER 14 GA X 13/16"OD X 25/64" ID
19	NC02-32-0012	4	LOCK WASHER ZINC 3/8"
20	NC02-07-0018	4	HEX. NUT ZINC 3/8-16
21	NC01-04-0110	4	CARR. BOLT GR2 ZINC 3/8-16 X 1 1/4"

#	PART #	Qty	TITLE
1	75-55-0050	1	U.H.M.W. BLACK WHEEL
2	NC14-70-0027	1	ROLLER BEARING
3	75-42-0100	2	PLASTIC WHEEL INTERNAL BUSHING

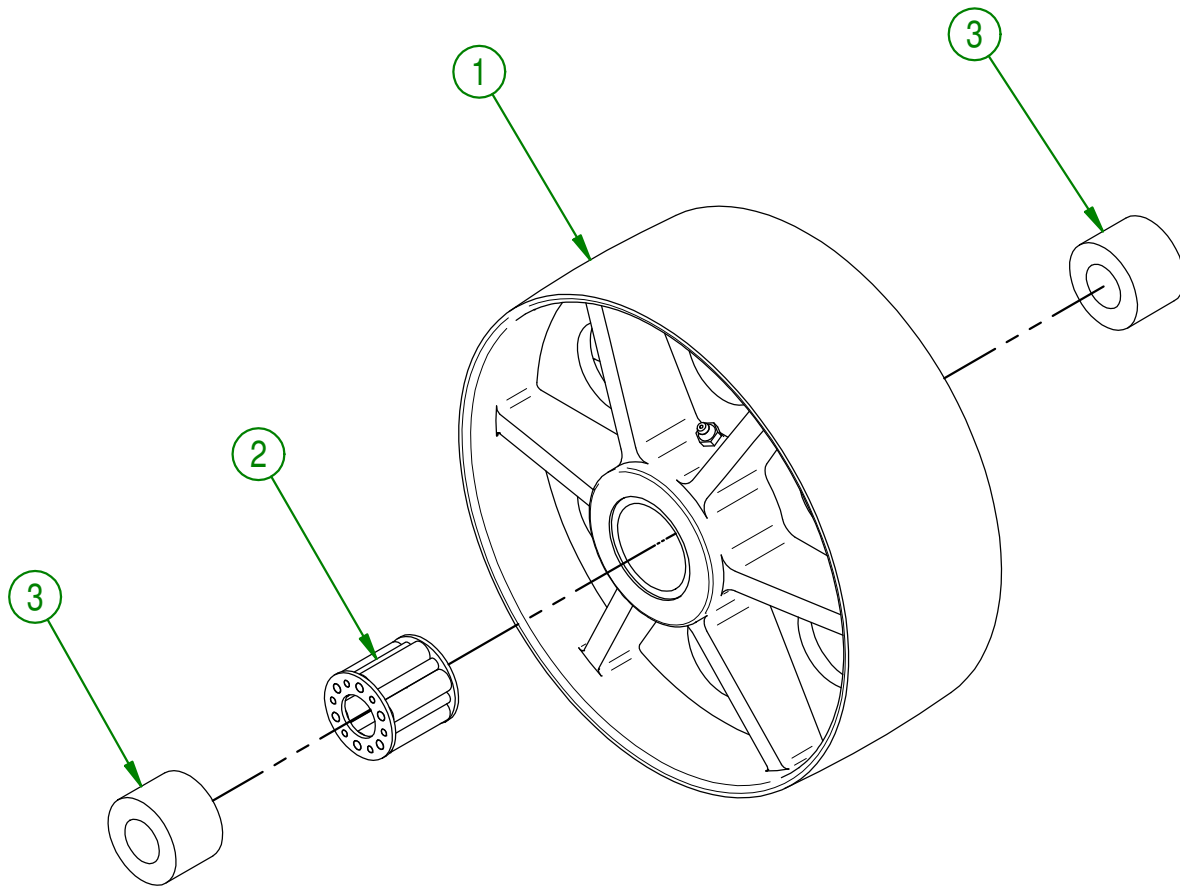
**AGRIMETAL****REAR U.H.M.W BLACK WHEEL**

CREATION : 16/04/20
 REVISION : 16/04/20

ASSEMBLY : **75-55-0055**

AUTHOR : J. Houle

Page 6 de 28

#	PART #	Qty	TITLE
1	75-55-0050	1	U.H.M.W. BLACK WHEEL
2	75-42-0100	1	PLASTIC WHEEL INTERNAL BUSHING
3	75-21-0020	1	PLASTIC WHEEL INTERNAL BUSHING
4	NCI4-75-0112	2	NEEDLE BEARING RC-121610
5	NCI4-70-0027	1	ROLLER BEARING

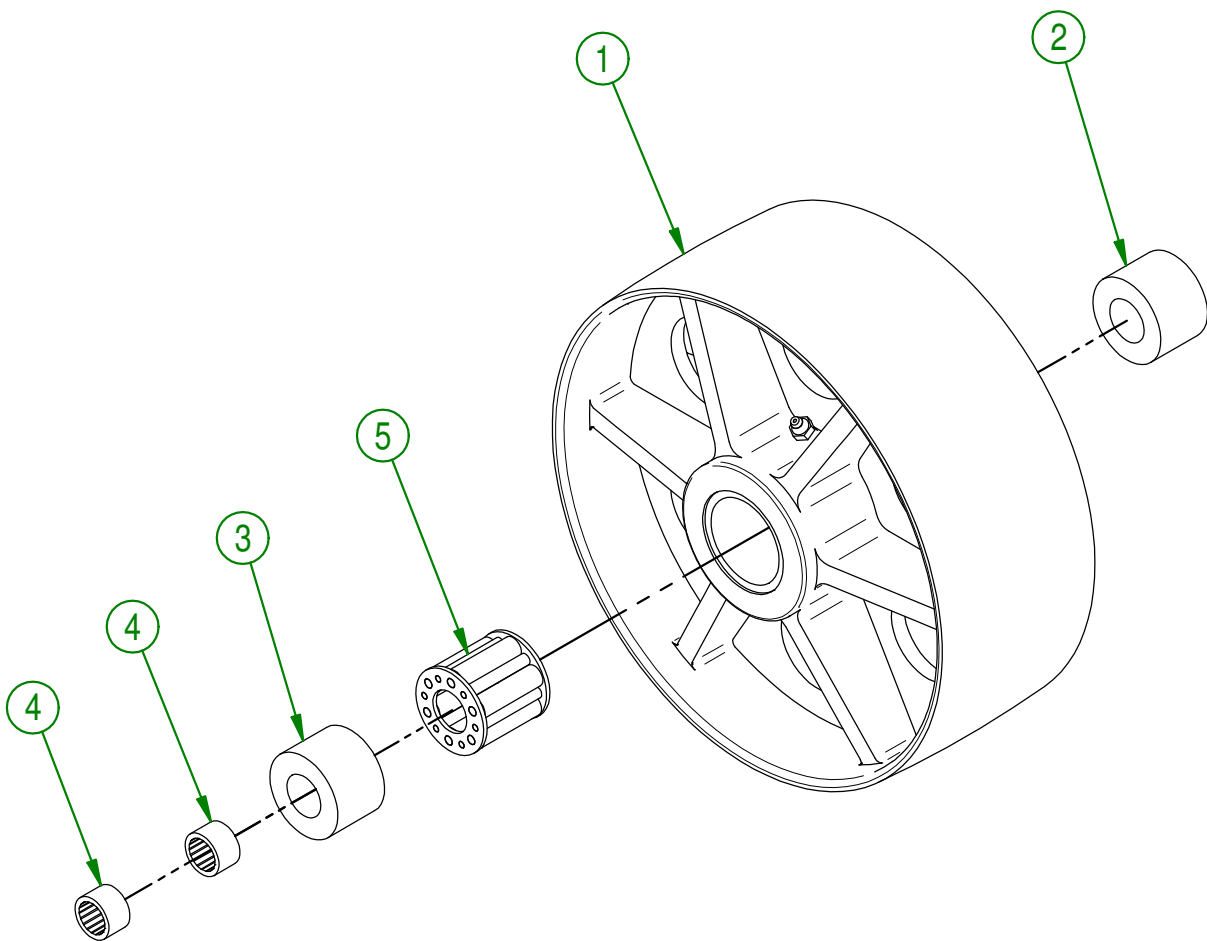
**AGRIMETAL**

FRONT U.H.M.W. BLACK WHEEL

CREATION : 16/04/20
 REVISION : 16/04/20

ASSEMBLY : **75-55-0060**

AUTHOR : J. Houle

Page 7 de 28

#	PART #	Qty	TITLE
1	NCI3-80-0238	1	PROFILE h-TYPE FOR BRUSH #7 X 24" LG.
2	NCI3-80-0236	1	BLACK NYLON BRUSH .030 X 1 1/2" X 25"
3	NC01-78-0016	8	ALUMINIUM BLIND POP RIVET STEEL MANDREL 0.187 X 0.690

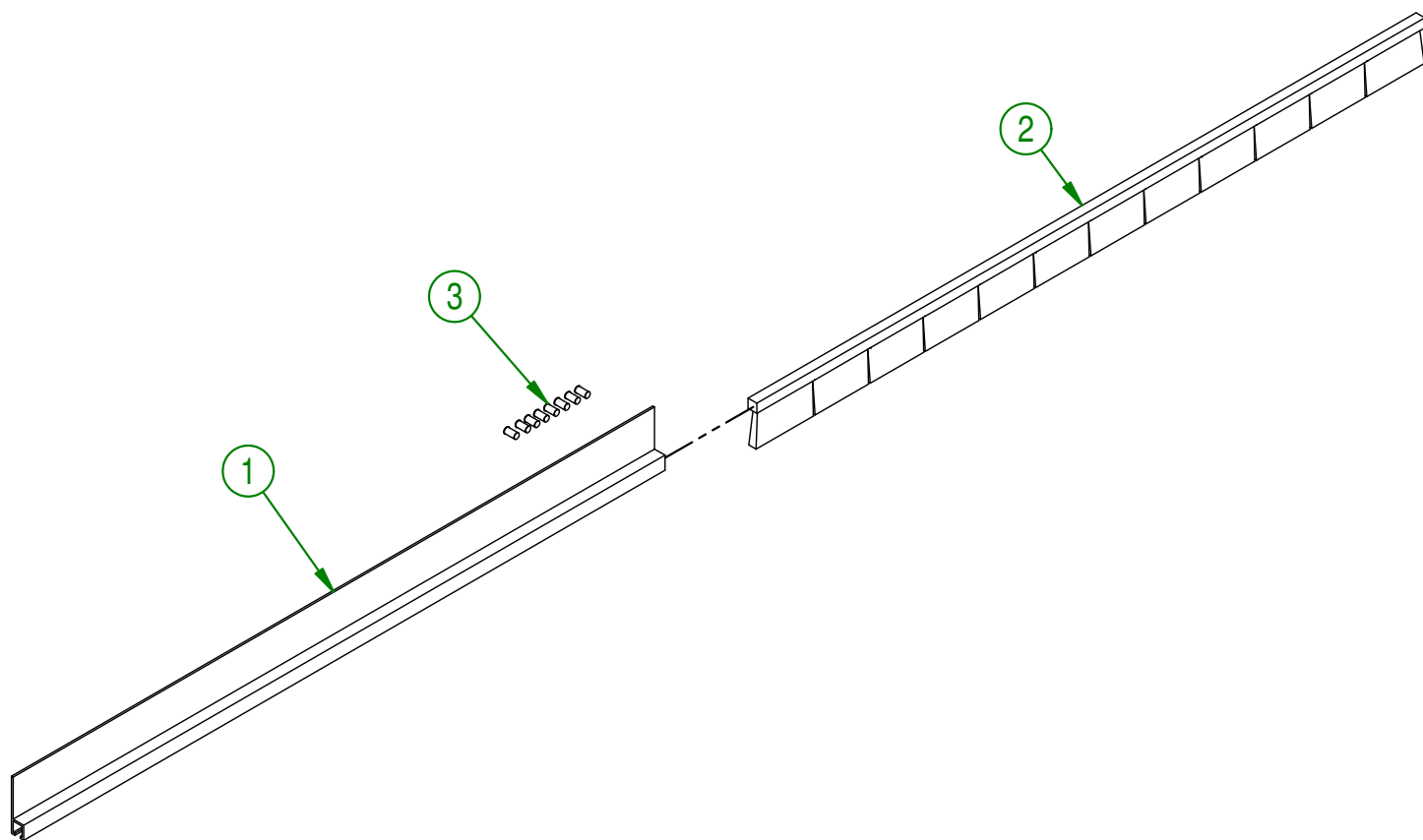

AGRIMETAL	
BRUSH 1 1/2" GROUP (FRONT)	
CREATION : 01/03/19	ASSEMBLY : 75-57-0025
REVISION : 01/03/19	AUTHOR : F.HÉLIE Page 8 de 28

75-57-0030

#	PART #	Qty	TITLE
1	75-50-0025	1	ADJUSTABLE WHEEL FRAME
2	NC01-17-0253	2	HEX. BOLT GR2 ZINC 1/2-13 X 2 1/2"
3	NC02-25-0011	6	WASHER SAE ZINC 17/32 ID
4	NC02-32-0014	2	LOCK WASHER ZINC 1/2"
5	NC01-96-0014	2	NYLON-INSERT LOCKNUT ZINC 1/2-13
6	01-01-1660	2	WASHER SPACER

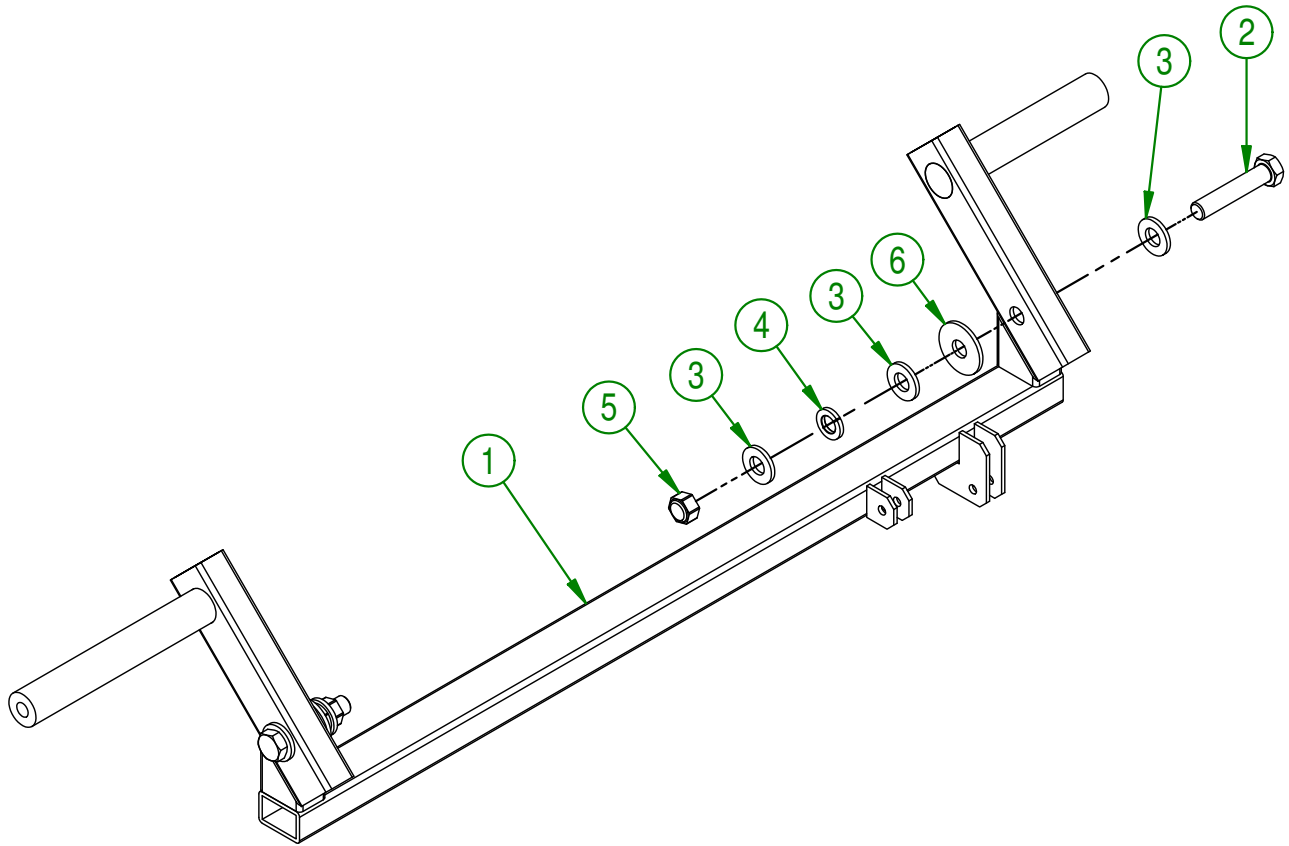

AGRIMETAL	
ADJUSTABLE WHEEL FRAME GROUP	
CREATION : 01/03/19	ASSEMBLY : 75-57-0030
REVISION : 01/03/19	AUTHOR : F.HÉLIE Page 9 de 28

75-57-0050

#	PART #	Qty	TITLE
1	75-55-0045	1	BRUSH 4" AND SUPPORT (REAR) ASSEMBLY
2	NC02-25-0007	3	WASHER ZINC 0.281 = 9/32
3	NC02-32-0010	3	LOCK WASHER ZINC 1/4"
4	NC01-17-0004	3	HEX. BOLT GR2 ZINC 1/4-20 X 3/4"

75-55-0045

#	PART #	Qty	TITLE
5	75-01-7600	1	REAR BRUSH SUPPORT
6	75-41-7250	1	PROFILE h-TYPE FOR BRUSH #7 X 24" LG
7	NC13-80-0237	1	BLACK NYLON BRUSH .030 X 1 1/2" HAUT X 25"
8	NC01-78-0016	8	ALUMINIUM BLIND POP RIVET STEEL MANDREL 0.187 X 0.690

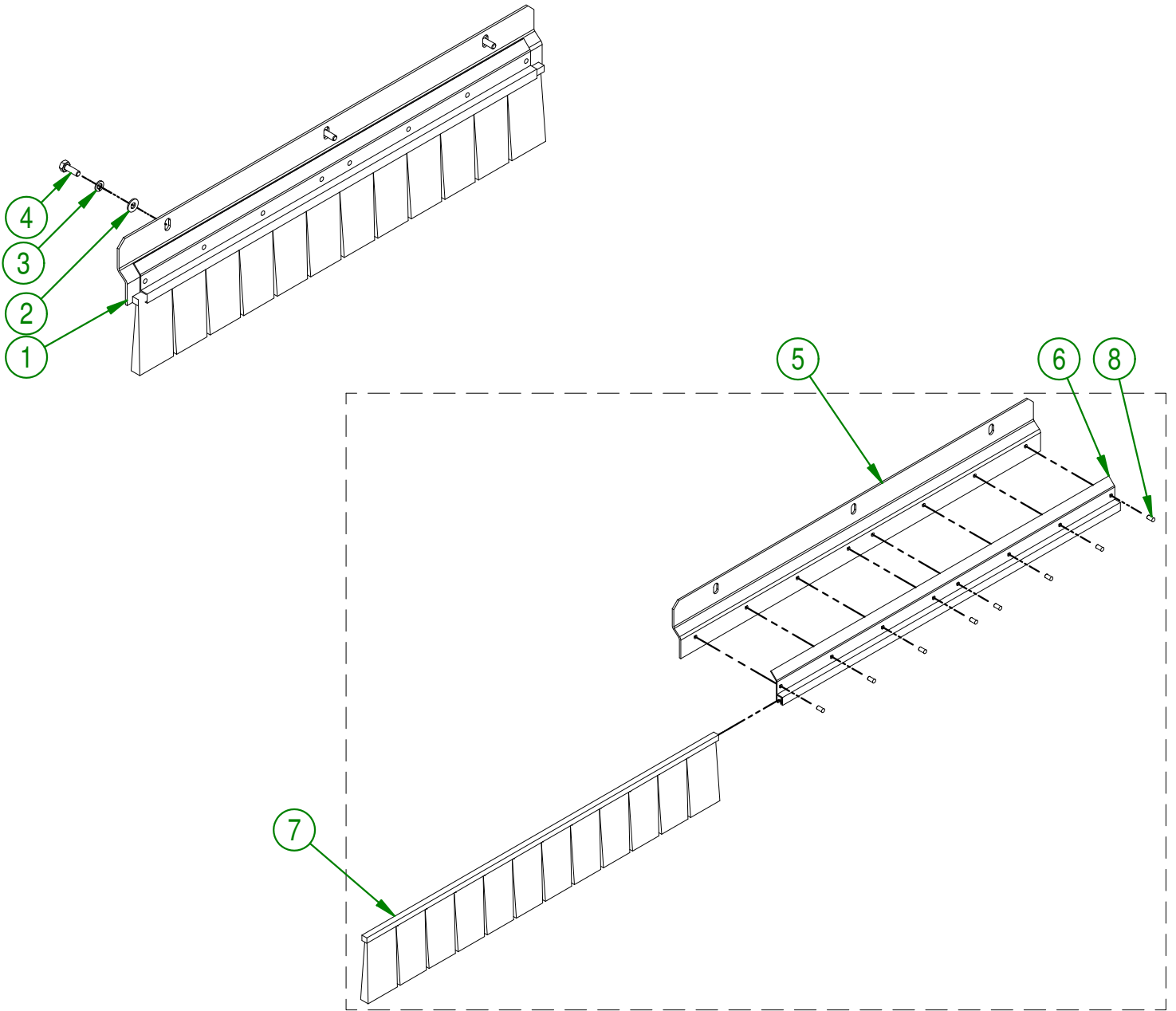

AGRIMETAL	
BRUSH 4" AND SUPPORT GROUP (REAR)	
CREATION : 01/03/19	ASSEMBLY : 75-57-0050
REVISION : 01/03/19	AUTHOR : F.HÉLIE Page 10 de 28

#	PART #	Qty	TITLE
1	75-13-0805	1	CLUTCH SHAFT
2	75-21-0075	1	CLUTCH
3	75-41-0900	1	KEY 3/16" X 3/16" X 4"
4	75-41-0905	1	KEY 3/16" X 3/16" X 9/16"
5	75-42-0160	1	MULTIPLE SPROCKET BUSHING
6	75-36-0100	1	SPROCKET
7	NC14-75-0108	1	BEARING SB 201-8 Ø 1/2"
8	NC14-75-0155	1	BEARING SB 202-10 Ø 5/8"
9	NC14-75-0136	4	PRESSED STEEL FLANGED HOUSING O.D. 3 3/16" PF203
10	NC14-55-0243	1	MULTIPLE SPROCKET
11	75-13-1800	1	CLUTCH OF CALIBRATED ROLLER
12	NC13-85-0037	1	COMPRESSION SPRING
13	NC01-04-0002	6	CARR. BOLT GR2 ZINC 1/4-20 X 5/8"
14	NC02-14-0017	6	FLANGED NUT GR. B 1/4-20
15	75-01-3045	1	CLUTCH COVER
16	NC01-17-0004	2	HEX. BOLT GR2 ZINC 1/4-20 X 3/4"
17	NC02-25-0007	2	WASHER ZINC 0.281 = 9/32
18*	NC01-96-0009	2	NYLON-INSERT LOCKNUT ZINC 1/4-20

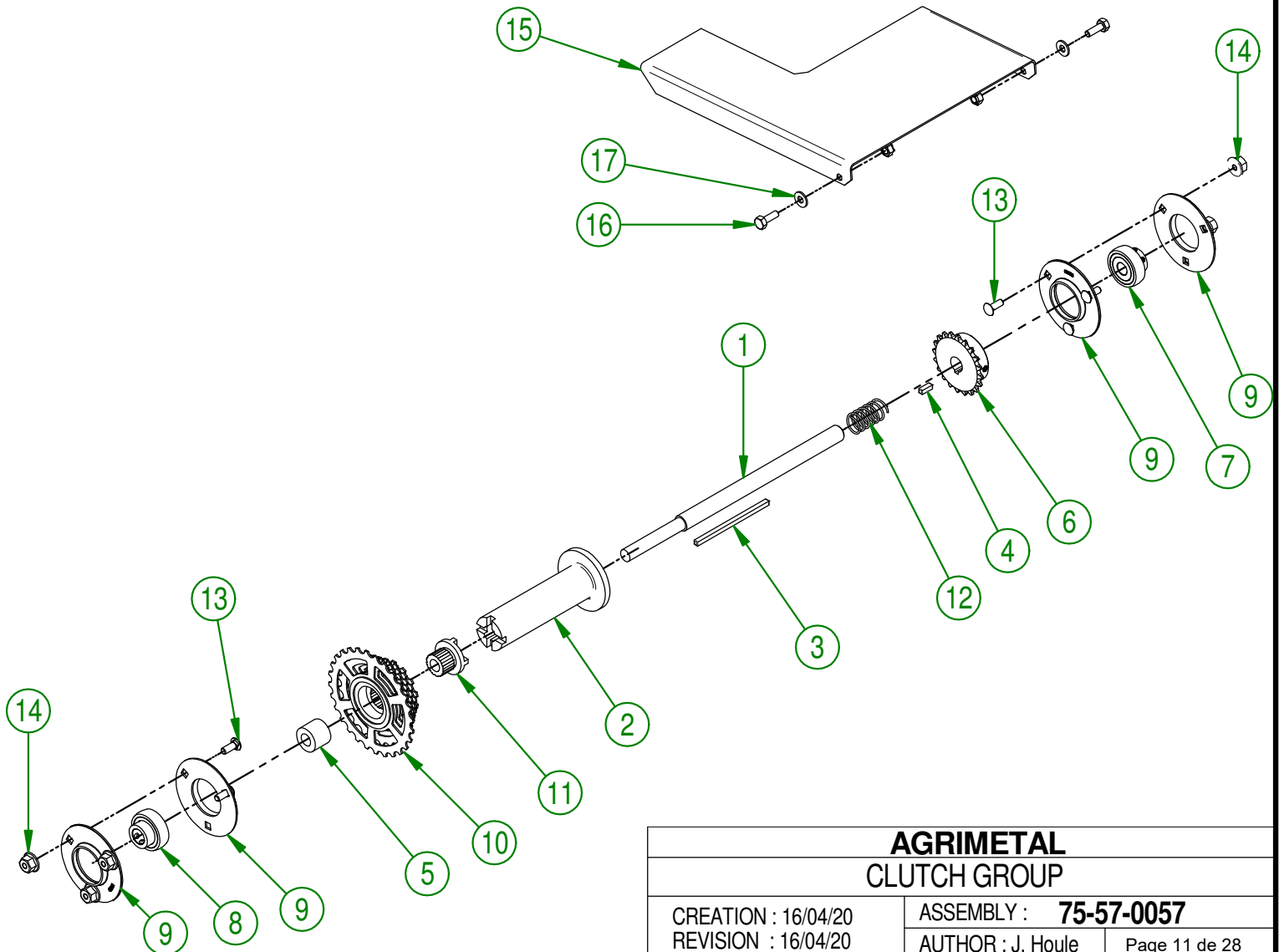

AGRIMETAL
CLUTCH GROUP

CREATION : 16/04/20
REVISION : 16/04/20

ASSEMBLY : **75-57-0057**

AUTHOR : J. Houle Page 11 de 28

#	PART #	Qty	TITLE
1	75-42-0170	2	CHAIN TENSIONER #35
2	NC01-96-0006	4	NYLON NUT ZINC 10-24
3	NC02-40-0085	4	MACHINE SCREW T.R. 10-24 X 1 1/2"
4	75-37-1000	1	CHAIN #35 X 36"

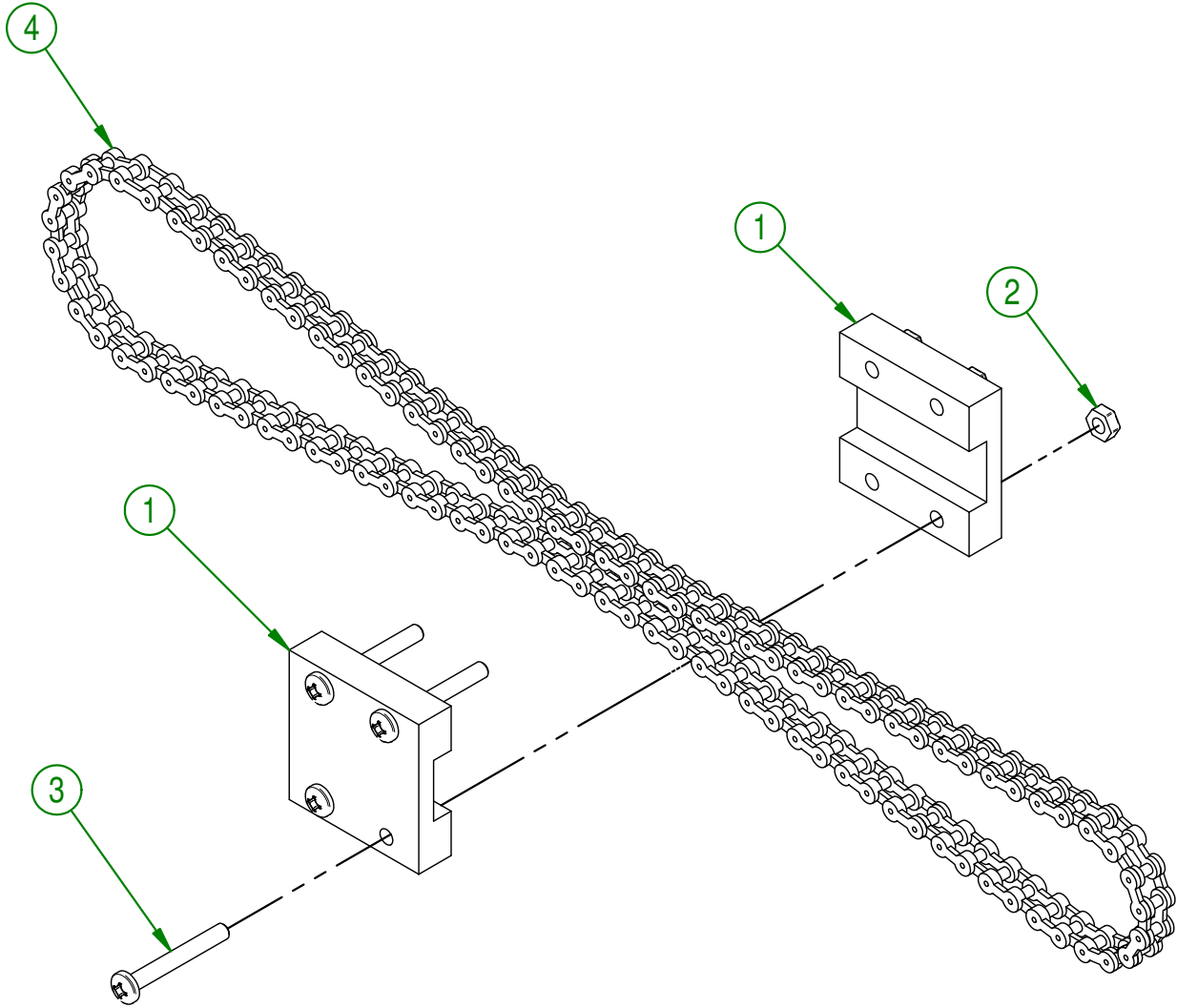

AGRIMETAL	
TENSIONER & ROTOR CLUTCH CHAIN GROUP	
CREATION : 01/03/19	ASSEMBLY : 75-57-0080
REVISION : 01/03/19	AUTHOR : F.HÉLIE Page 12 de 28

#	PART #	Qty	TITLE
1	75-01-3110	2	DISTRIBUTOR SHAFT SHIM
2	75-10-0100	6	ASSEMBLY GUIDE
3	75-01-7555	1	CLUTCH BOX BRACE
4	NC01-04-0002	3	CARR. BOLT GR2 ZINC 1/4-20 X 5/8"
5	NC01-17-0003	1	HEX. BOLT GR2 ZINC 1/4-20 X 5/8"
6	NC02-25-0007	6	WASHER ZINC 0.281 = 9/32
7	NC02-14-0017	7	FLANGED NUT GR. B 1/4-20
8	NC01-96-0009	3	NYLON-INSERT LOCKNUT ZINC 1/4-20
9	75-01-1560	1	CALIBRATED ROLLER LOCK
10	75-22-2600	1	HEAT SHIELD
11	NC02-40-0080	3	MACHINE SCREWS SQUARE SOCKET #10-24 X 1/2" LG
12	NC01-96-0006	3	NYLON NUT ZINC 10-24
13	NC02-41-0012	1	T METAL HEX. TAPPING SCREW 12 X 1"
14	NC01-17-0020	6	HEX BOLT GR2 NC ZINC 1/4-20 X 4 1/2" LG.

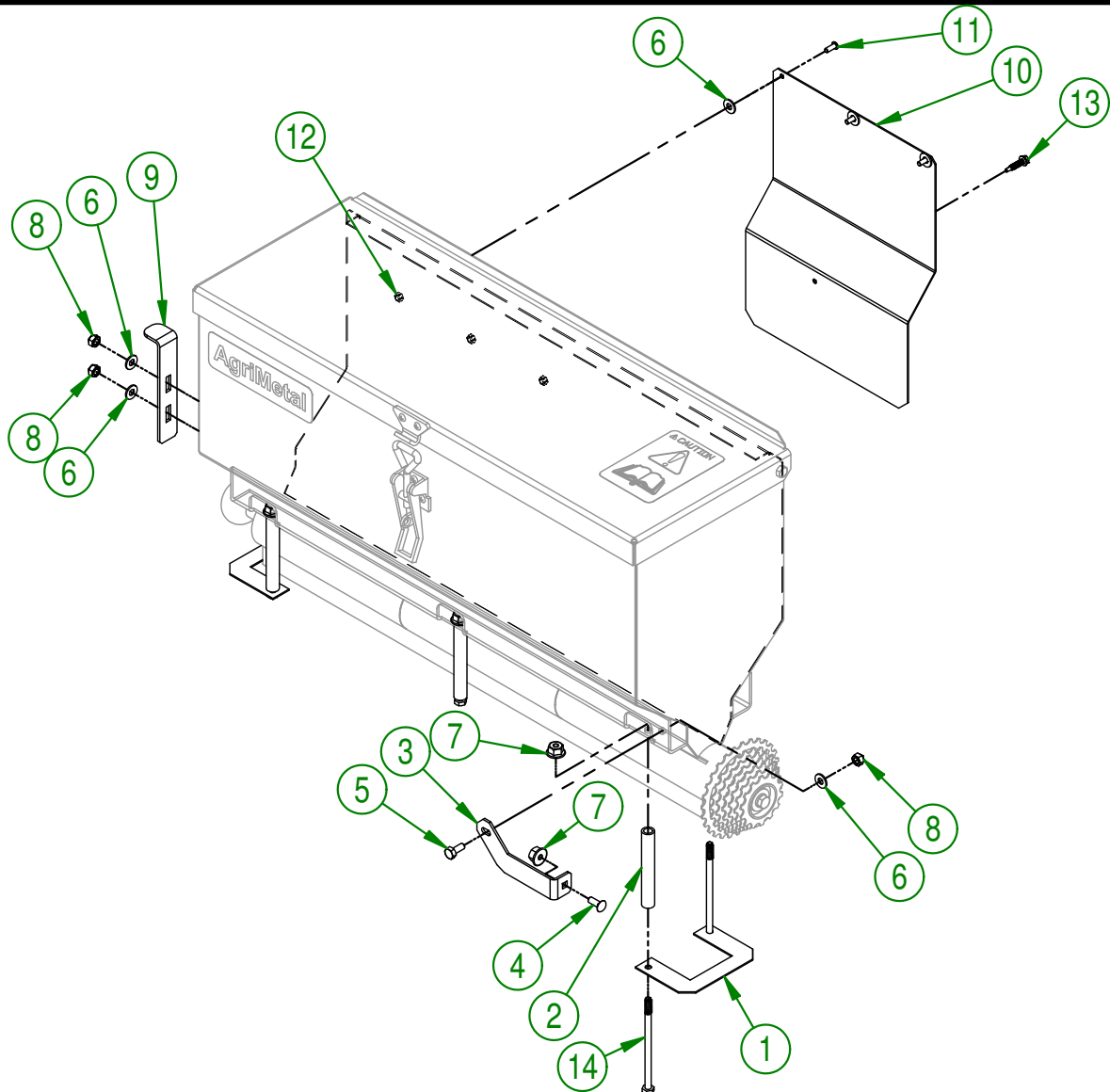

AGRIMETAL
SEED BOX GROUP

CREATION : 01/03/19
REVISION : 01/03/19

ASSEMBLY : **75-57-0090**

AUTHOR : F.HÉLIE Page 13 de 28

#	PART #	Qty	TITLE
1	75-57-0095	1	SEED BOX GROUP
2	NC01-63-0036	1	DRAW LATCH 6 1/2"
3	NC01-63-0037	1	DRAW LATCH STRIKER
4	NC02-40-0080	5	MACHINE SCREWS SQUARE SOCKET #10-24 X 1/2" LG
5	NC01-96-0006	5	NYLON NUT ZINC 10-24
6	75-42-0205	2	BLACK ADHESIVE-BACK STRIP
7	75-42-0200	2	BLACK ADHESIVE-BACK STRIP

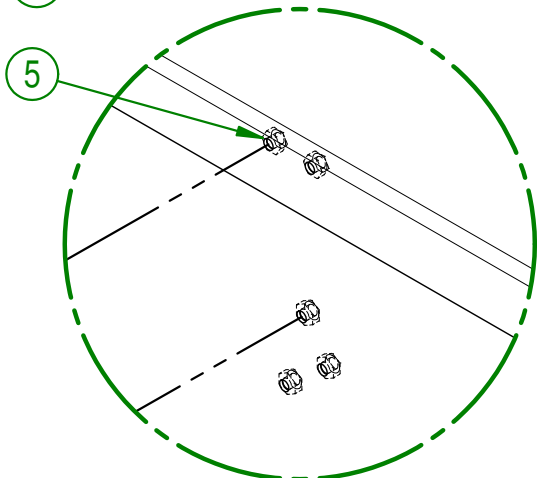
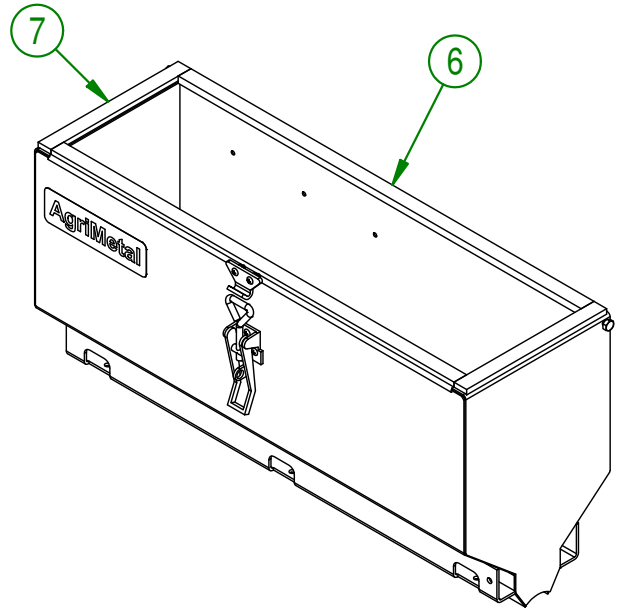
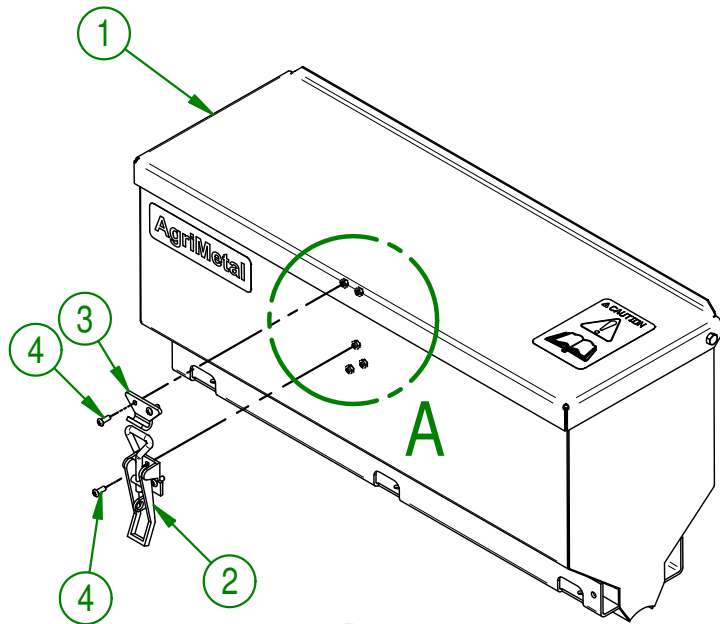

DETAIL A

AGRIMETAL	
SEED BOX ASSEMBLY	
CREATION : 01/03/19	ASSEMBLY : 75-55-0090
REVISION : 01/03/19	AUTHOR : F.HÉLIE Page 14 de 28

75-55-0040

#	PART #	Qty	TITLE
1	75-55-0100	1	DISTRIBUTOR TUBE ASSEMBLY
2	NC14-75-0070	2	6205-2RS BEARING
3	NC01-64-0159	1	INTERNAL RETAINING RING 2 1/16" HOLE
4	NC14-55-0243	1	MULTIPLE SPROCKET
5	NC01-17-0058	1	HEX. BOLT GR2 ZINC 5/16-18 X 3/4"
6	NC02-32-0011	1	LOCK WASHER ZINC 5/16"
7	75-13-1600	1	CALIBRATED ROLLER DRIVE SHAFT
8	75-42-0165	1	CALIBRATED ROLLER MULTIPLE SPROCKET BUSHING
9	75-42-0605	1	SEED CALIBRATED ROLLER "BEND"
10	21-01-0950	1	FLAT WASHER IOGA 1.005" DIA X 25/64"

75-55-0100

#	PART #	Qty	TITLE
11	75-21-0002	1	DISTRIBUTOR TUBE (CENTER)
12	75-21-0001	1	DISTRIBUTOR TUBE (RIGHT)
13	75-21-0003	1	DISTRIBUTOR TUBE (LEFT)
14	75-21-0105	1	SEED DISTRIBUTOR ROD
15	NC01-69-0373	9	SPRING PIN 1/8" X 1/2" ZINC

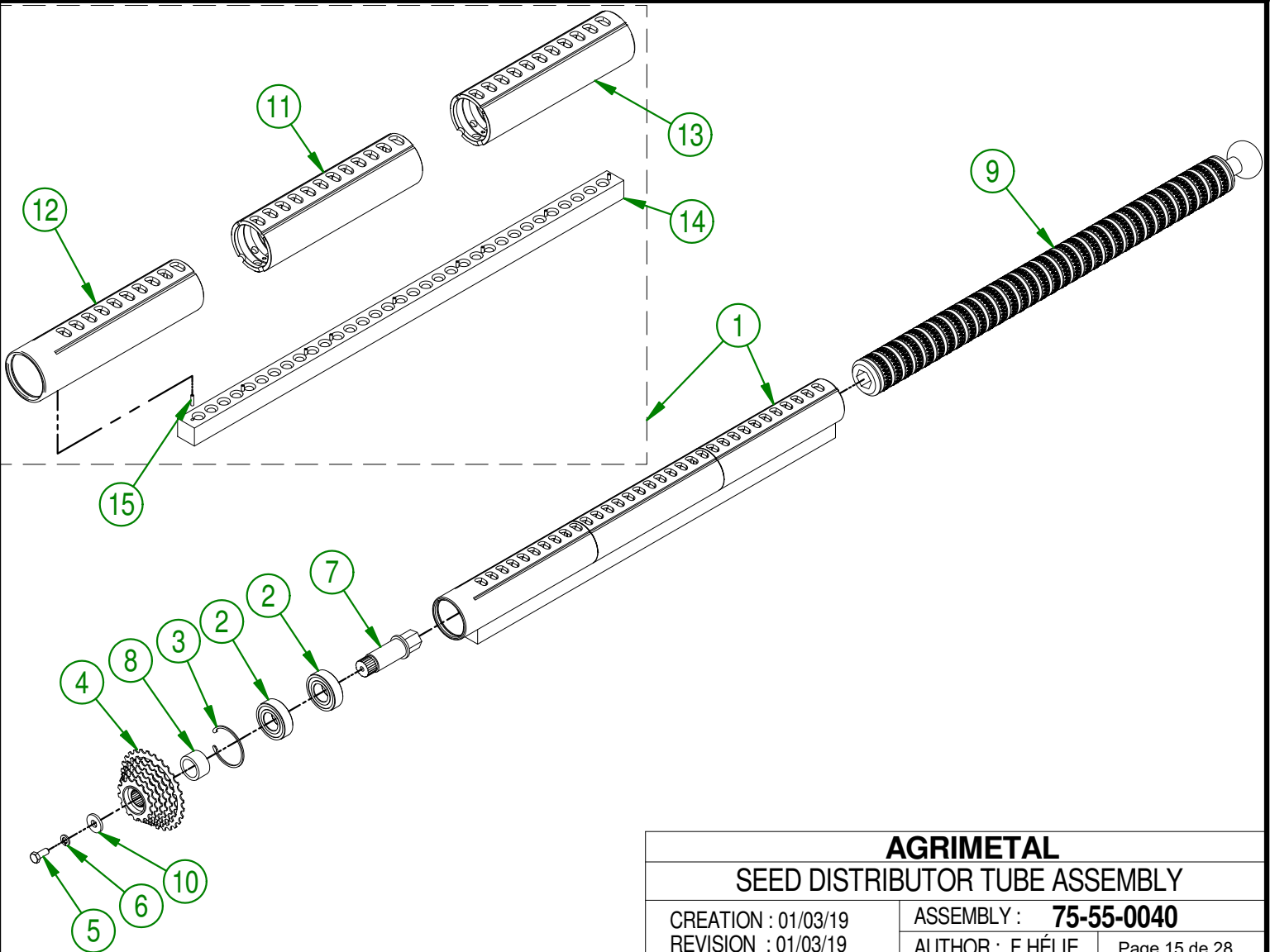

AGRIMETAL	
SEED DISTRIBUTOR TUBE ASSEMBLY	
CREATION : 01/03/19	ASSEMBLY : 75-55-0040
REVISION : 01/03/19	AUTHOR : F.HÉLIE Page 15 de 28

#	PART #	Qty	TITLE
1	75-57-0125	1	CHAIN TENSIONER GROUP
2	75-37-1005	1	BICYCLE CHAIN 22 1/4" ASSEMBLY
3	NC17-46-0018	1	HANDLE KNOB
4	NC02-07-0018	1	HEX. NUT ZINC 3/8-16

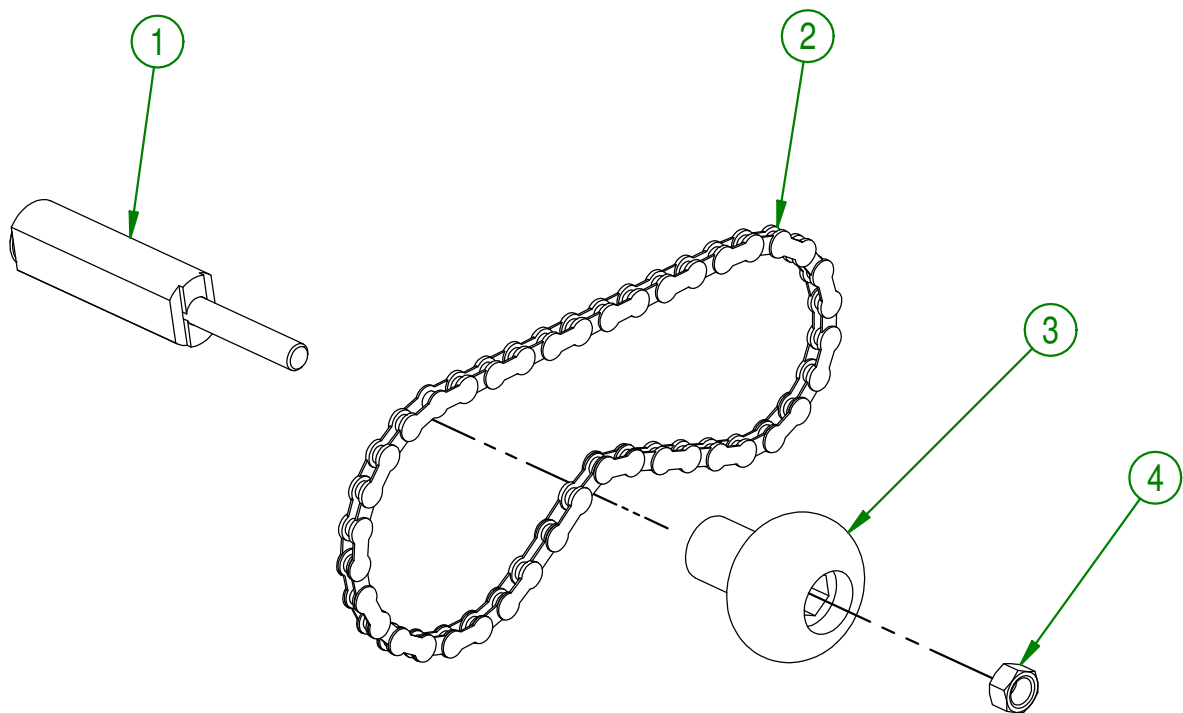

AGRIMETAL	
TENSIONER & MULTIPLE SPROCKET CLUTCH CHAIN GROUP	
CREATION : 01/03/19	ASSEMBLY : 75-57-0120
REVISION : 02/06/20	AUTHOR : F.HÉLIE Page 16 de 28

75-57-0140

#	PART #	Qty	TITLE
1	75-31-0100	1	ADJUSTABLE SCREW
2	NC02-07-0018	1	HEX. NUT ZINC 3/8-16
3	NC01-67-0102	1	INTERNALLY THREADED BALL JOINT ROD END 1/4-28
4	75-21-0005	1	HANDLE BLACK KNOB INSERT
5	NC17-46-0018	1	HANDLE KNOB
6	NC01-96-0011	1	NYLON NUT 3/8-16
7	01-01-2485	1	FLAT WASHER 14 GA X 13/16"OD X 25/64" ID
8	NC01-17-0006	1	HEX. BOLT 1/4-20 X 1"
9	NC01-96-0009	1	NYLON-INSERT LOCKNUT ZINC 1/4-20

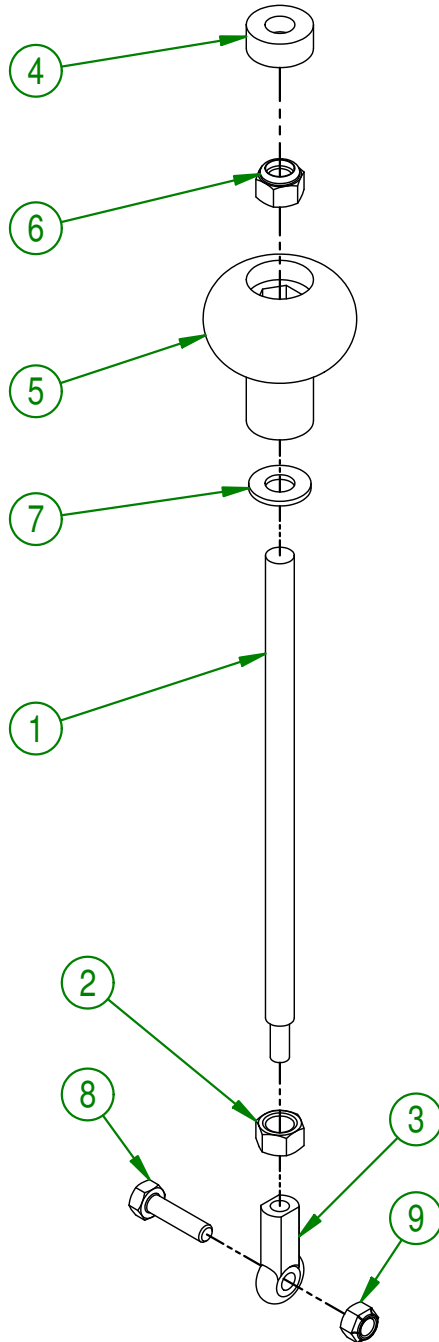

AGRIMETAL

REAR WHEEL ADJUSTABLE SCREW GROUP

CREATION : 04/03/19
 REVISION : 04/03/19

ASSEMBLY : **75-57-0140**

AUTHOR : F.HÉLIE | Page 17 de 28

#	PART #	Qty	TITLE
1	75-46-0525	33	SEED URETHANE TUBE

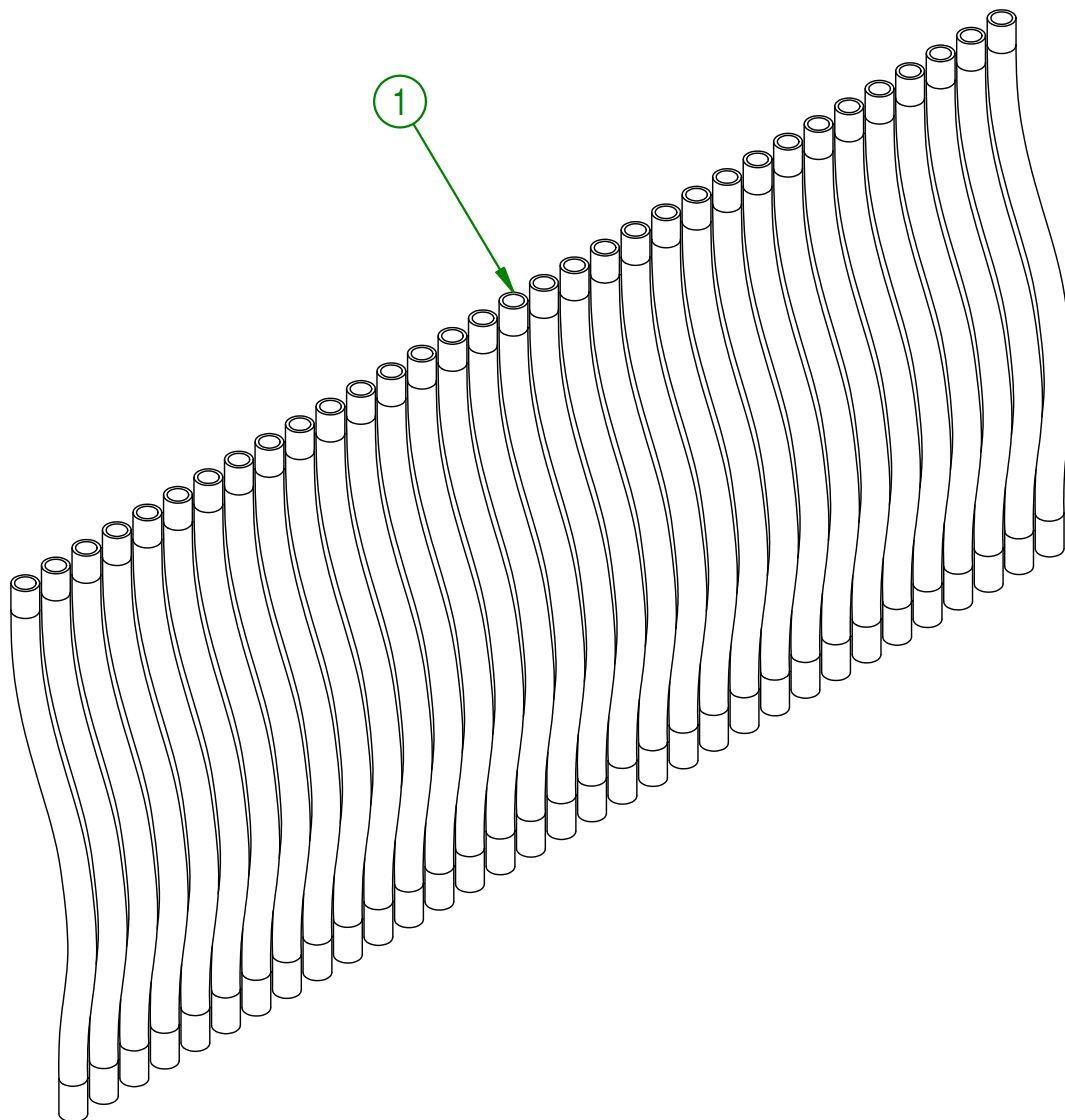

AGRIMETAL	
SEED DISTRIBUTOR TUBE GROUP	
CREATION : 04/03/19	ASSEMBLY : 75-57-0145
REVISION : 04/03/19	AUTHOR : F.HÉLIE Page 18 de 28

#	PART #	Qty	TITLE
1	26-03-4800	8	WASHER
2	NC13-15-0059	4	YELLOW RUBBER BASE MOUNT
3	01-33-0010	8	WASHER
4	NC01-17-0119	4	HEX. BOLT GR2 ZINC 3/8-16 X 2 1/4"
5	NC02-32-0012	4	LOCK WASHER ZINC 3/8"
6	NC02-07-0018	4	HEX. NUT ZINC 3/8-16
7	NC14-25-1071	1	V BELT 21/32" (BX-32)
8	NC13-85-0008	1	GALVANISED SPRING

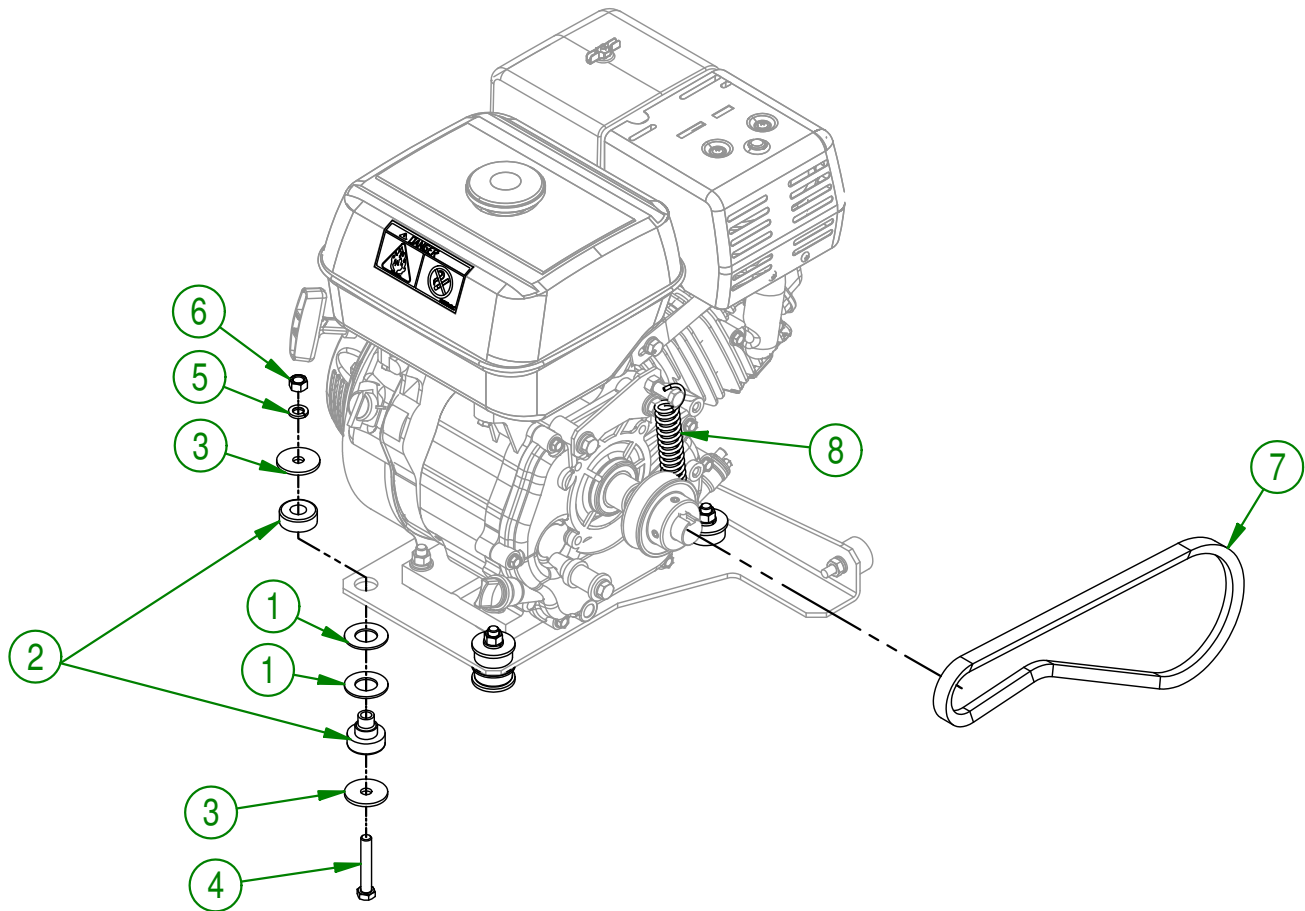
**AGRIMETAL****HONDA 9 H.P.(MANUAL) MOTOR GROUP**

CREATION : 04/03/19
 REVISION : 04/03/19

ASSEMBLY : **75-57-0150**

AUTHOR : F.HÉLIE | Page 19 de 28

#	PART #	Qty	TITLE
1	01-03-5405	1	MUFFLER SUPPORT
2	NC01-45-0188	1	BOLT MET.GR2 NF ZINC 8MM X 35MM
3	NC02-32-0011	2	LOCK WASHER ZINC 5/16"
4	NC02-22-0008	2	WASHER ZINC 5/16"
5	75-13-1425	1	MOTOR (9 HP) TENSIONER SHAFT
6	75-04-0025	1	MOTOR BASE (9 HP)
7	NC01-17-0117	4	HEX. BOLT GR2 ZINC 3/8-16 X 1 3/4"
8	01-01-2485	4	FLAT WASHER 14 GA X 13/16"OD X 25/64" ID
9	NC02-32-0012	5	LOCK WASHER ZINC 3/8"
10	NC02-07-0018	4	HEX. NUT ZINC 3/8-16
11	21-01-0950	1	FLAT WASHER 10GA 1.005" DIA X 25/64"
12	NC01-65-0087	1	KEY 1/4 X 1/4 X 1 1/2"
13	NC01-17-0119	1	HEX. BOLT GR2 ZINC 3/8-16 X 2 1/4"
14	NC14-62-0212	1	MB30X1/2 PULLEY
15	NC13-15-0034	1	RUBBER ABSORBER
16	NC02-07-0017	1	HEX. NUT 5/16-18
17	NC13-37-0519	1	ARRESTER SPARK

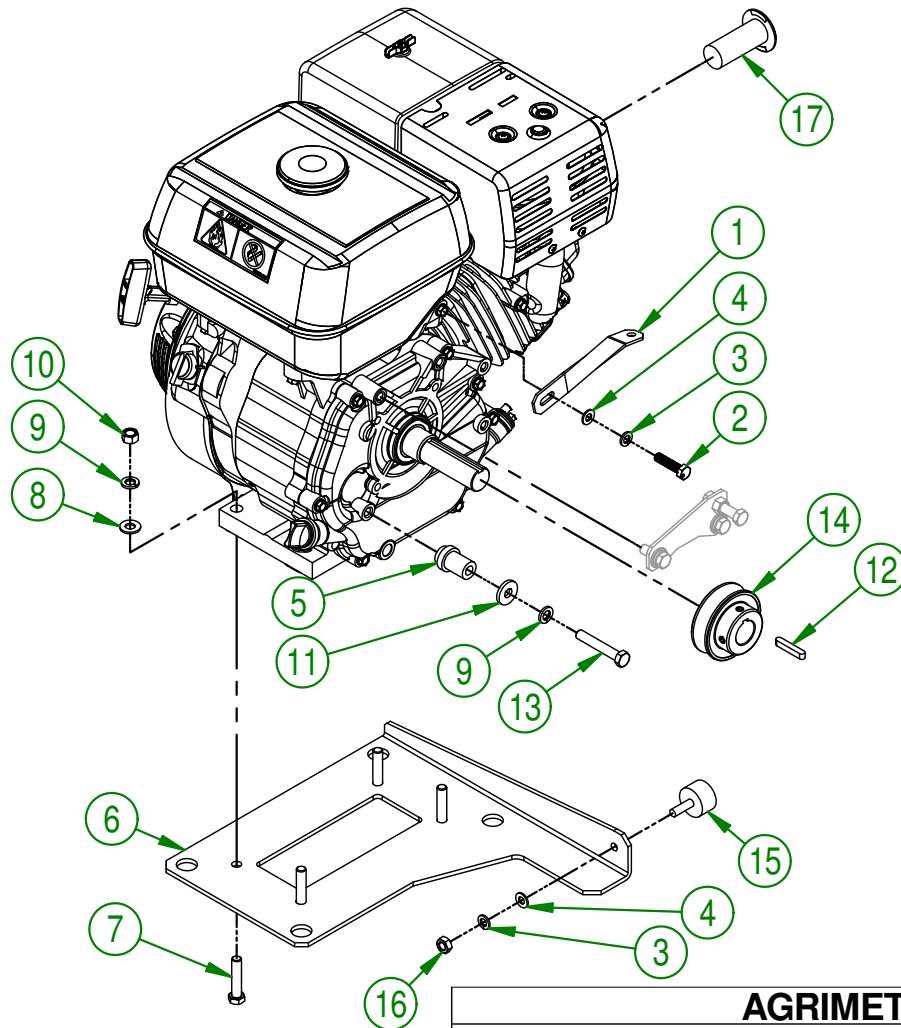
**AGRIMETAL****HONDA (MANUAL) MOTOR 9 H.P. ASSEMBLY**

CREATION : 04/03/19

REVISION : 30/08/19

ASSEMBLY : **75-55-0025**

AUTHOR : F.HÉLIE

Page 20 de 28

#	PART #	Qty	TITLE
1	75-01-0980	1	TENSIONER SPRING SUPPORT
2	01-01-2485	2	FLAT WASHER 14 GA X 13/16"OD X 25/64" ID
3	NC01-17-0117	1	HEX. BOLT GR2 ZINC 3/8-16 X 1 3/4"
4	NC01-17-0114	2	HEX. BOLT GR2 ZINC 3/8-16 X 1"
5	NC02-32-0012	3	LOCK WASHER ZINC 3/8"
6	NC02-07-0018	2	HEX. NUT ZINC 3/8-16

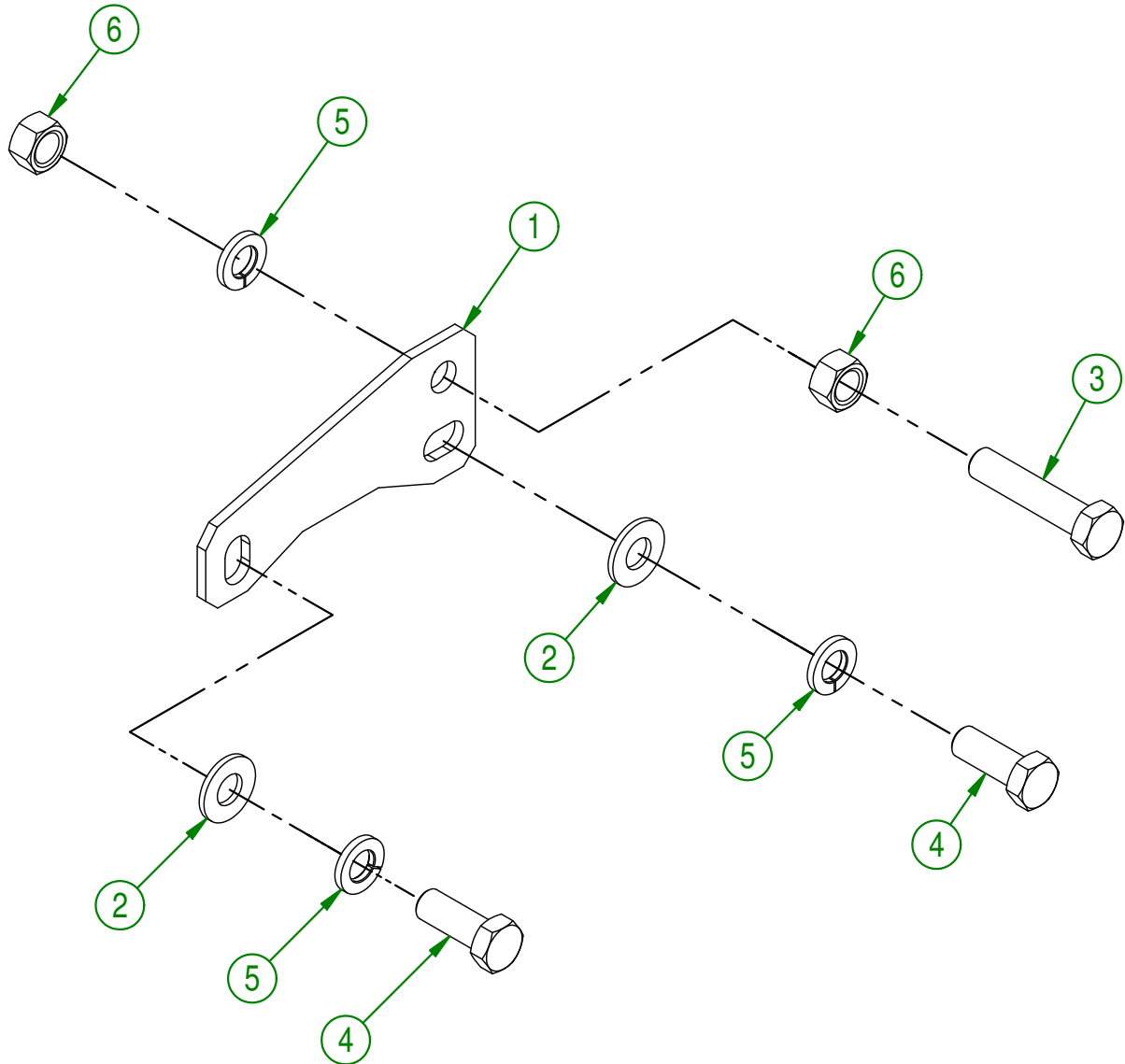
**AGRIMETAL****TENSIONER SPRING SUPPORT GROUP**

CREATION : 04/03/19
 REVISION : 04/03/19

ASSEMBLY : **75-57-0190**

AUTHOR : F.HÉLIE | Page 21 de 28

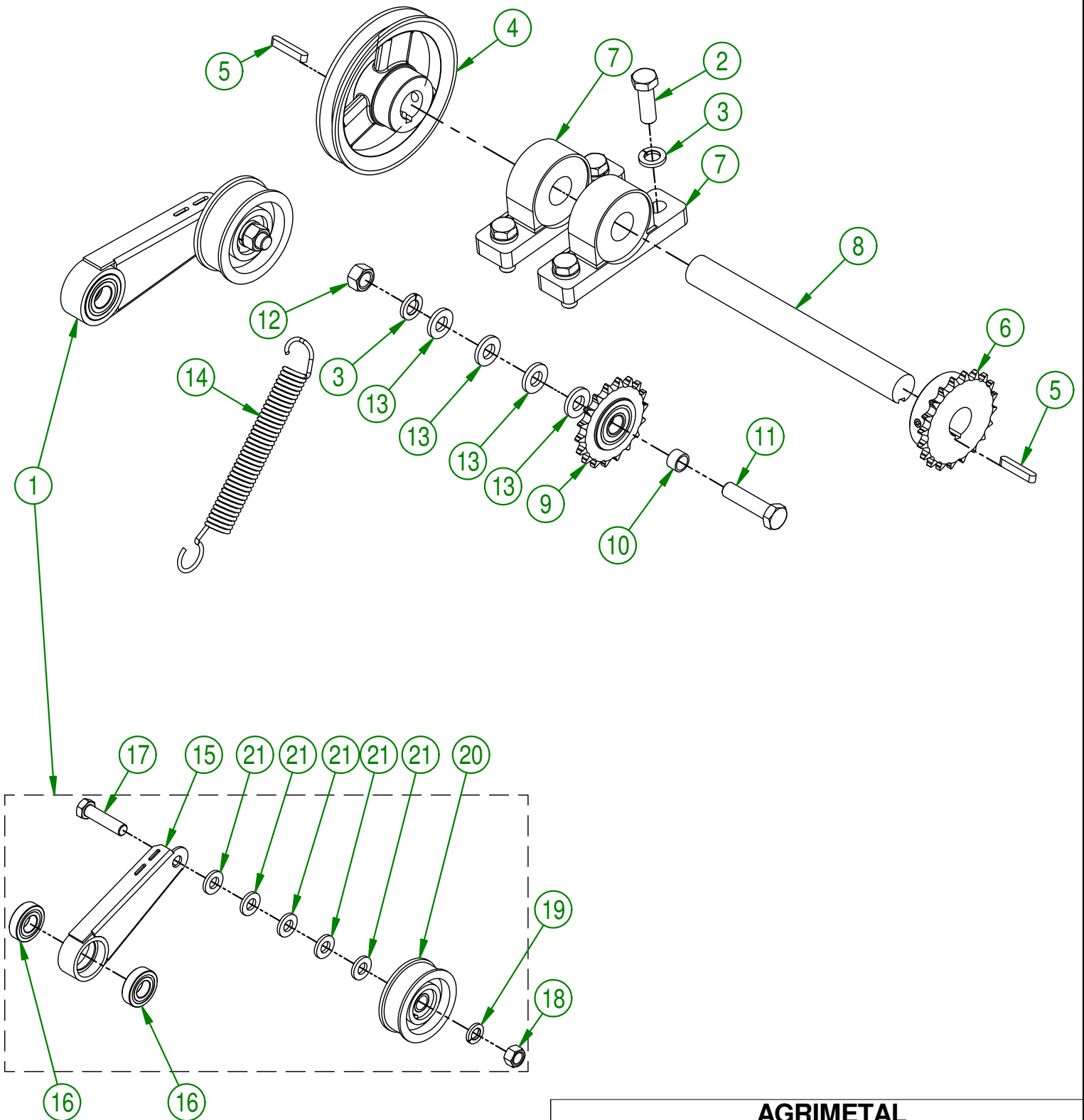

AGRIMETAL
ROTOR DRIVE GROUP

CREATION : 04/03/19
 REVISION : 04/03/19

ASSEMBLY : **75-57-0155**

AUTHOR : F.HÉLIE | Page 22 de 28

75-57-0155

#	PART #	Qty	TITLE
1	75-55-0095	1	BELT TENSIONER ARM
2	NC01-17-0249	4	HEX. BOLT GR2 ZINC 1/2-13 X 1 1/2"
3	NC02-32-0014	5	LOCK WASHER ZINC 1/2"
4	NC14-62-0213	1	PULLEY (MB55 X Ø 1" KW 1/4" 2 SS)
5	NC01-65-0087	2	KEY 1/4 X 1/4 X 1 1/2"
6	NC14-55-0254	1	SPROCKET 40B20 X Ø 1" K.W. 1/4" 2SS
7	03-38-0000	2	PILLOW BLOCK UCP205-16 X 1" ID
8	75-13-1410	1	INTERMEDIATE SHAFT
9	NC14-55-0305	1	SPROCKET 40C18H X 6202 X Ø 5/8" SPEC.
10	NC13-80-0061	1	PAD STEEL POWDER 1/2" X 5/8" X 3/8"
11	NC01-17-0251	1	HEX. BOLT GR2 ZINC 1/2-13 X 2"
12	NC02-07-0020	1	HEX. NUT ZINC 1/2-13
13	01-01-0925	4	WASHER
14	NC13-85-0008	1	GALVANISED SPRING

75-55-0095

#	PART #	Qty	TITLE
15	75-50-0065	1	BELT TENSIONER
16	NC14-75-0110	2	BALL BEARING R12 2RS
17	NC01-17-0251	1	HEX. BOLT GR2 ZINC 1/2-13 X 2"
18	NC02-07-0020	1	HEX. NUT ZINC 1/2-13
19	NC02-32-0014	1	LOCK WASHER ZINC 1/2"
20	01-39-0600	1	IDLER PULLEY PI-300 ASSY
21	01-01-0925	5	WASHER

AGRIMETAL
ROTOR DRIVE GROUP

CREATION : 04/03/19
 REVISION : 04/03/19

ASSEMBLY : **75-57-0155**
 AUTHOR : F.HÉLIE | Page 23 de 28

#	PART #	Qty	TITLE
1	75-57-0170	1	BELT GUARD GROUP (STICKER INCLUDED)
2	NC01-64-0005	2	OVAL SLEEVE (ALUMINUM)
3	NC01-17-0004	3	HEX. BOLT GR2 ZINC 1/4-20 X 3/4"
4	NC02-32-0010	3	LOCK WASHER ZINC 1/4"
5	NC02-25-0007	3	WASHER ZINC 0.281 = 9/32
6	75-41-0135	1	BELT GUARD WIRE Ø1/16 X 18" LG.

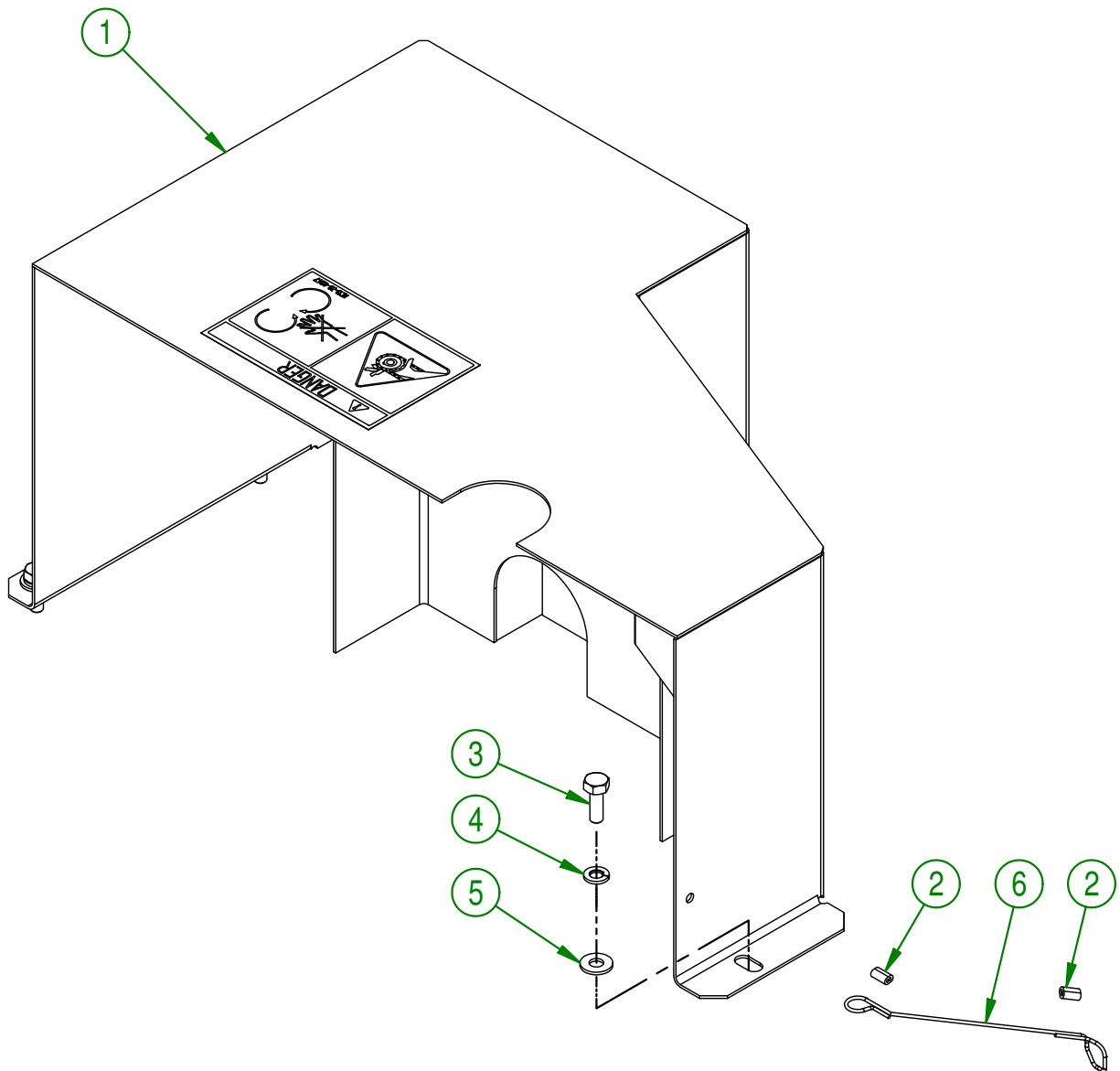

AGRIMETAL
BELT GUARD GROUP

CREATION : 04/03/19
REVISION : 04/03/19

ASSEMBLY : **75-57-0165**

AUTHOR : F.HÉLIE | Page 24 de 28

75-57-0175

#	PART #	Qty	TITLE
1	NC14-75-0009	4	PRESSED STEEL FLANGED HOUSING F5 O.D. 3 3/4"
2	NC14-75-0016	2	SEAL BALL BEARING SB 205-16
3	NC01-04-0056	7	CARR. BOLT 5/16-18 X3/4"
4	NC02-14-0006	6	HEX. NUT SPECIAL FLANGET NC 5/16-18 B GRADE
5	75-04-0035	2	ROTOR BEARING PLATE
6	NC01-17-0112	8	HEX. BOLT GR2 ZINC 3/8-16 X 3/4"
7	NC02-32-0012	8	LOCK WASHER ZINC 3/8"
8	33-41-0900	1	SQUARE KEY
9	NC14-55-0250	1	SPROCKET 40B28H X 1" (K.W. 1/4" 2SS)
10	75-37-1010	1	CHAIN #40 X 30" + 1 LINK

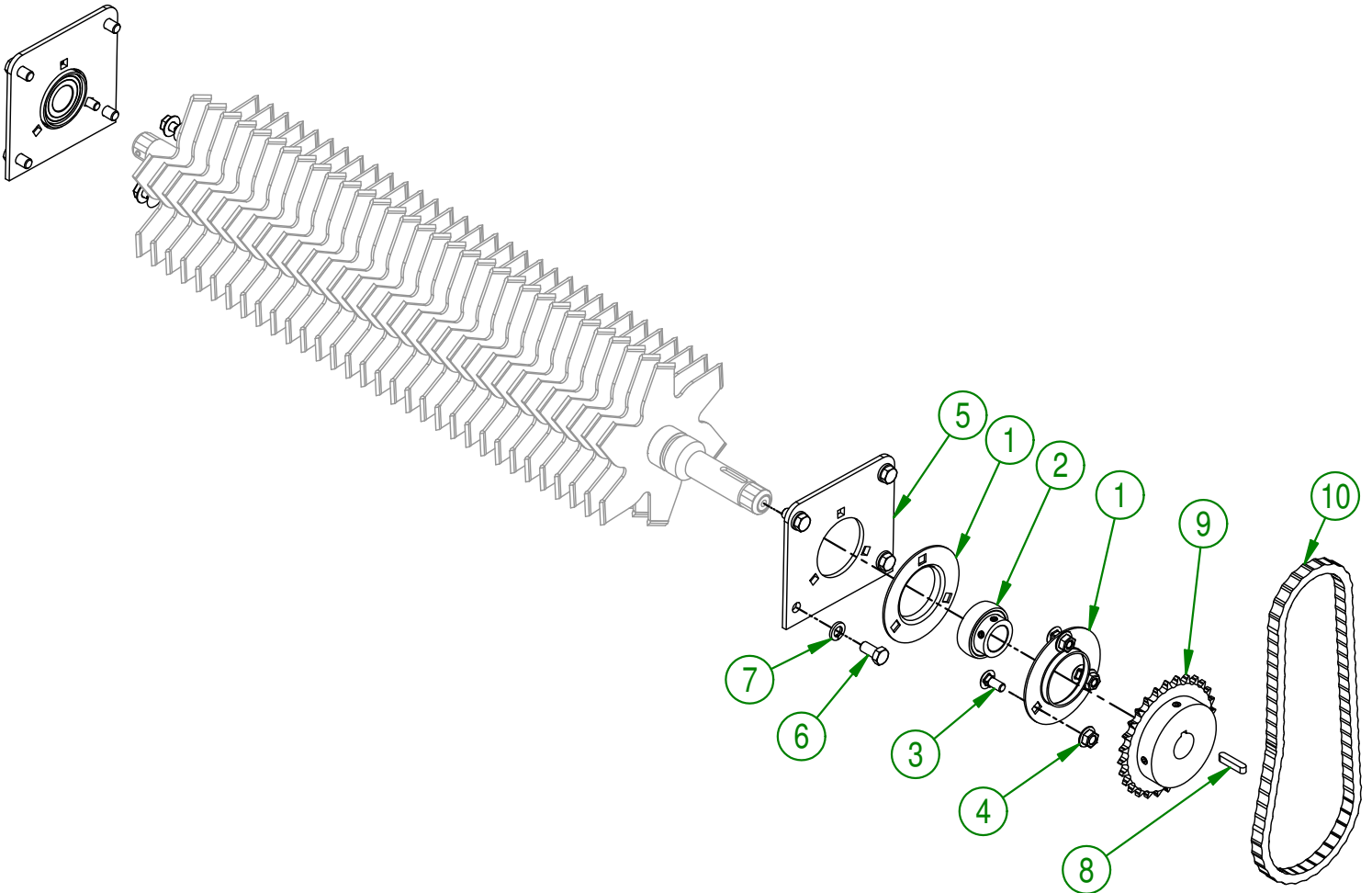

AGRIMETAL	
ROTOR GROUP	
CREATION : 04/03/19	ASSEMBLY : 75-57-0175
REVISION : 04/03/19	AUTHOR : F.HÉLIE Page 25 de 28

75-55-0086

#	PART #	Qty	TITLE
1	75-55-0081	1	ROTOR SHAFT
2	75-21-0056	32	BLADE BUSHING 0.110" X 3/4" C/C
3	47-41-0900	1	SQUARE KEY
4	75-13-2000	1	ROTOR DRIVE TIP
5	75-32-9950	1	ROTOR NYLON INSERT LOCKNUT
6	NC13-22-0026	32	ROTOR BLADE

75-55-0081

#	PART #	Qty	TITLE
7	75-25-2400	1	ROTOR SHAFT
8	47-41-0900	1	SQUARE KEY
9	75-13-2005	1	ROTOR LOCK TIP
10	75-32-9950	1	ROTOR NYLON INSERT LOCKNUT
11	NC01-69-0419	1	SPRING TIGHTENER PIN ZINC 3/16 XI"

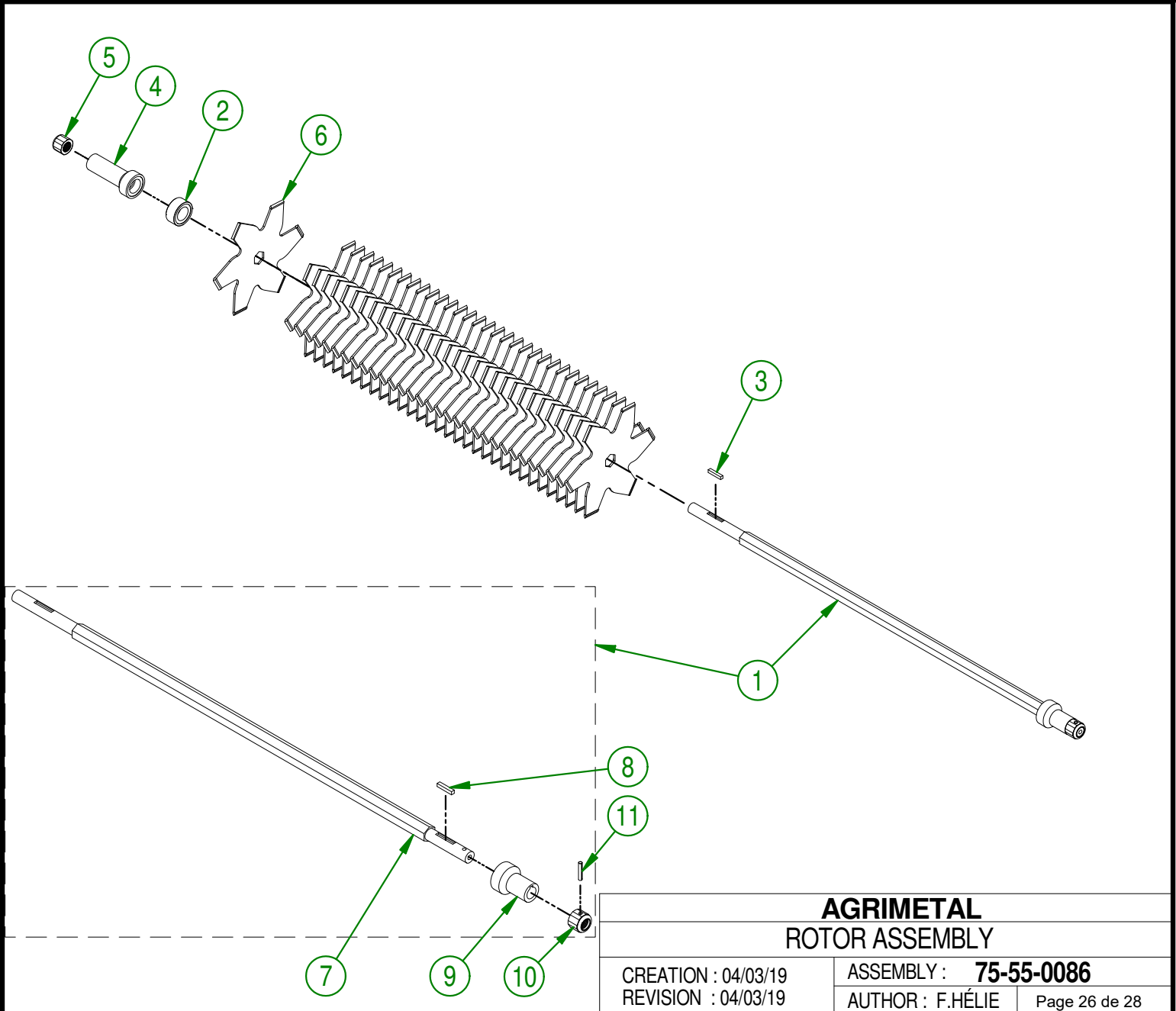

AGRIMETAL
ROTOR ASSEMBLY

CREATION : 04/03/19
REVISION : 04/03/19

ASSEMBLY : **75-55-0086**

AUTHOR : F.HÉLIE Page 26 de 28

#	PART #	Qty	TITLE
1	NC13-30-0237	1	PLASTIC TUBE FOR OPERATOR'S MANUAL
2	NC01-04-0003	3	CARR. BOLT GR2 ZINC 1/4-20 X 3/4"
3	NC02-25-0007	3	WASHER ZINC 0.281 = 9/32
4	NC01-96-0009	3	NYLON-INSERT LOCKNUT ZINC 1/4-20
5	75-98-0520	1	OPÉR.MAN.OVERSEEDER (ENGLISH)
6	01-55-0030	1	DRAIN OIL SLAB "STICKER INCLUDED"

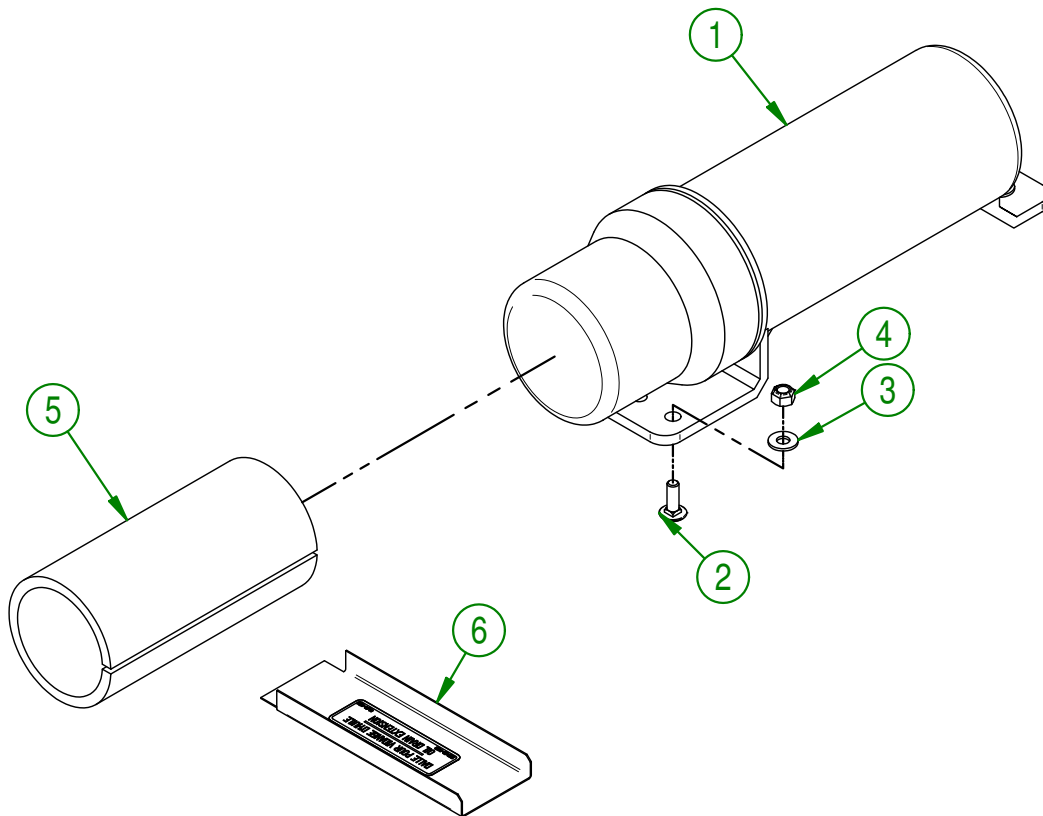
**AGRIMETAL****OPERATOR'S MANUAL GROUP**

CREATION : 16/01/19
 REVISION : 04/03/19

ASSEMBLY : **75-57-0178**

AUTHOR : F.HÉLIE | Page 27 de 28

#	PART #	Qty	TITLE
1	NCI3-33-0189	1	STICKER DANGER (PERSON AND CHAIN DRIVE)
2	NCI3-33-0247	1	STICKER DANGER
3	NCI3-33-0002	2	STICKER AGRIMETAL
4	NCI3-33-0183	1	STICKER CAUTION OPERATION MANUAL
5	NCI3-33-0197	1	STICKER SEEDING RATE BY SPROCKETS
6	NCI3-33-0252	1	STICKER (FIRE RISK)
7	NCI3-33-0023	1	STICKER OIL DRAIN EXTENSION

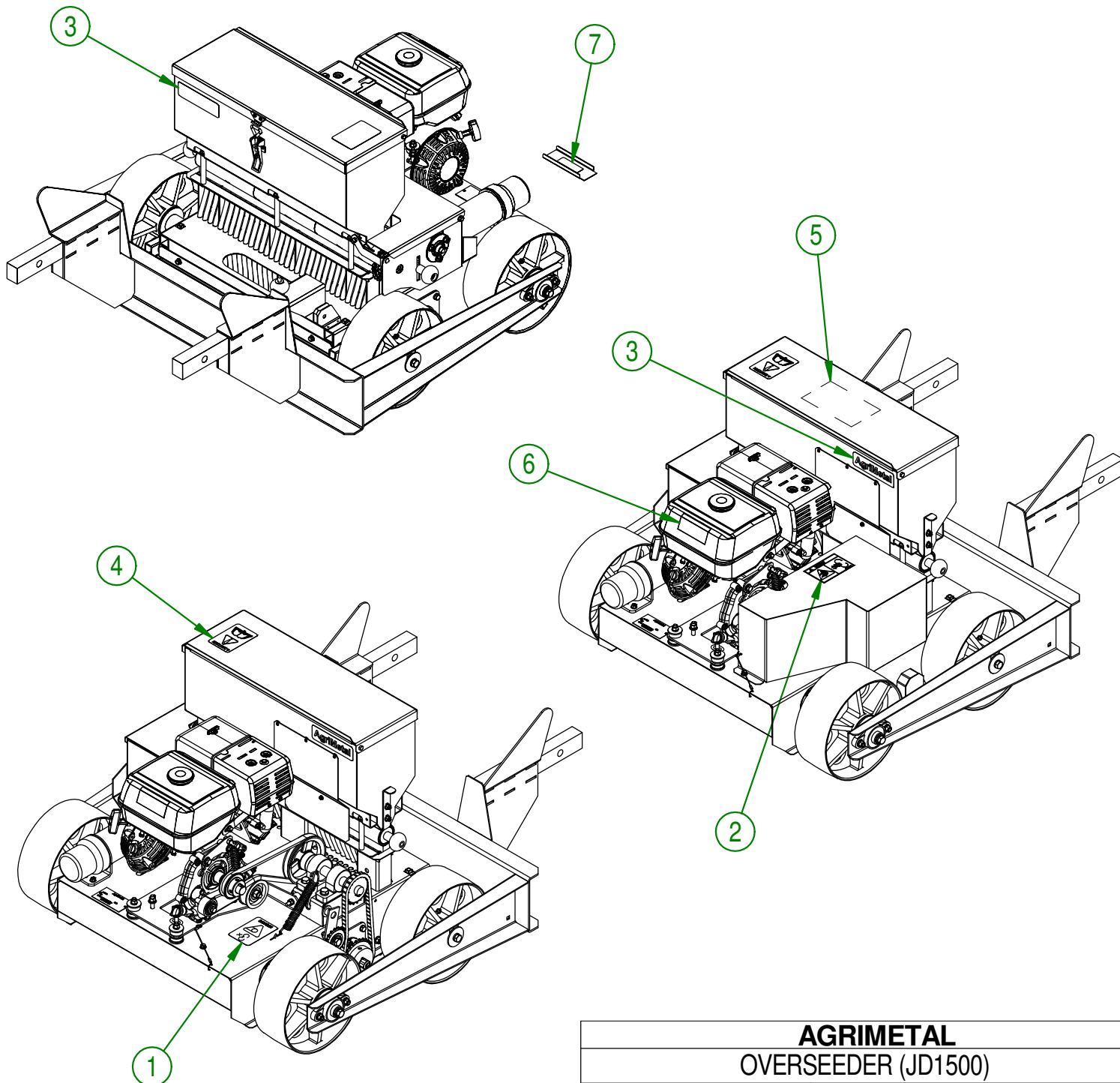

AGRIMETAL
OVERSEEDER (JD1500)

CREATION : 20/04/20
REVISION : 21/04/20

ASSEMBLY : **75-99-0500**

AUTHOR : J. Houle Page 28 de 28