

# 1 INTRODUCTION

Congratulations on your choice of an AgriMetal Front mount Leaf Blower to complement your operation. This equipment has been designed and manufactured to meet the needs of a discerning turf care industry.

Safe, efficient and trouble free operation of your AgriMetal Leaf Blower requires that you and anyone else who will be operating or maintaining the machine, read and understand the Safety, Operation, Maintenance and Trouble Shooting information contained within the Operator's Manual.



This manual covers the Models BWF 180 JD, BWF 180 Toro and BWF 180 Kubota Front mount Leaf Blower. Use the Table of Contents or Index as a guide to locate required information.

Keep this manual handy for frequent reference and to pass on to new operators or owners. Call your AgriMetal Dealer or Distributor if you need assistance, information or additional copies of the manuals.

**OPERATOR ORIENTATION** - The directions left, right, front and rear, as mentioned throughout this manual, are as seen from behind the tractor driver's seat and facing in the direction of travel.

## 2 SAFETY

### SAFETY ALERT SYMBOL

This Safety Alert symbol means **ATTENTION! BECOME ALERT! YOUR SAFETY IS INVOLVED!**



The Safety Alert symbol identifies important safety messages on the AgriMetal Front mount Leaf Blower and in the manual. When you see this symbol, be alert to the possibility of personal injury or death. Follow the instructions in the safety message.

Why is SAFETY important to you?

#### 3 Big Reasons

**Accidents Disable and Kill**  
**Accidents Cost**  
**Accidents Can Be Avoided**

#### SIGNAL WORDS:

Note the use of the signal words **DANGER**, **WARNING** and **CAUTION** with the safety messages. The appropriate signal word for each message has been selected using the following guide-lines:

**SI NO LEE INGLES, PIDA AYUDA A AIGUIEN QUE SI LO LEA PARA QUE LE TRADUZCA LAS MIDIDAS DE SEGURIDAD.**

**DANGER** - Indicates an imminently hazardous situation that, if not avoided, will result in death or serious injury. This signal word is to be limited to the most extreme situations typically for machine components which, for functional purposes, cannot be guarded.

**WARNING** - Indicates a potentially hazardous situation that, if not avoided, could result in death or serious injury, and includes hazards that are exposed when guards are removed. It may also be used to alert against unsafe practices.

**CAUTION** - Indicates a potentially hazardous situation that, if not avoided, may result in minor or moderate injury. It may also be used to alert against unsafe practices.

If you have any questions not answered in this manual or require additional copies or the manual is damaged, please contact your dealer or AgriMetal Inc., 1006 Rue Principale, Wickham, Quebec, Canada, J0C 1S0. Phone (819) 398-6883 or fax (819) 398-5311.

# SAFETY

**YOU** are responsible for the SAFE operation and maintenance of your AgriMetal Front mount Leaf Blower. **YOU** must ensure that you and anyone else who is going to operate, maintain or work around the Leaf Blower be familiar with the operating and maintenance procedures and related **SAFETY** information contained in this manual. This manual will take you step-by-step through your working day and alerts you to all good safety practices that should be adhered to while operating the Leaf Blower.

Remember, **YOU** are the key to safety. Good safety practices not only protect you but also the people around you. Make these practices a working part of your safety program. Be certain that **EVERYONE** operating this equipment is familiar with the recommended operating and maintenance procedures and follows all the safety precautions. Most accidents can be prevented. Do not risk injury or death by ignoring good safety practices.

- Leaf Blower owners must give operating instructions to operators or employees before allowing them to operate the machine, and at least annually thereafter per OSHA (Occupational Safety and Health Administration) regulation 1928.57.
- The most important safety device on this equipment is a SAFE operator. It is the operator's responsibility to read and understand ALL Safety and Operating instructions in the manual and to follow these. Most accidents can be avoided.
- A person who has not read and understood all operating and safety instructions is not qualified to operate the machine. An untrained operator exposes himself and bystanders to possible serious injury or death.
- Do not modify the equipment in any way. Unauthorized modification may impair the function and/or safety and could affect the life of the equipment.
- Think SAFETY! Work SAFELY!

## 2.1 GENERAL SAFETY

1. Read and understand the Operator's Manual and all safety signs before operating, maintaining, adjusting or unplugging the Leaf Blower.



2. Have a first-aid kit available for use should the need arise and know how to use it.



3. Have a fire extinguisher available for use should the need arise and know how to use it.

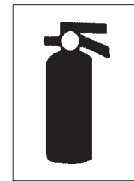

4. Do not allow riders.

5. Wear appropriate protective gear. This list includes but is not limited to:

- A hard hat
- Protective shoes with slip resistant soles
- Protective glasses or goggles
- Heavy gloves
- Wet weather gear
- Hearing protection
- Respirator or filter mask



6. Install and secure all guards before starting.

7. Wear suitable ear protection for prolonged exposure to excessive noise.

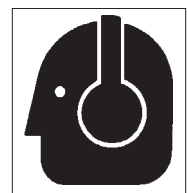

8. Place all controls in neutral, stop engine, set park brake, remove ignition key and wait for all moving parts to stop before servicing, adjusting, repairing or unplugging.

9. Clear the area of people, especially small children, before starting the unit.

10. Review safety related items annually with all personnel who will operating or maintaining the Leaf Blower.

## 2.2 EQUIPMENT SAFETY GUIDELINES

1. Safety of the operator and bystanders is one of the main concerns in designing and developing a machine. However, every year many accidents occur which could have been avoided by a few seconds of thought and a more careful approach to handling equipment. You, the operator, can avoid many accidents by observing the following precautions in this section. To avoid personal injury or death, study the following precautions and insist those working with you, or for you, follow them.
2. In order to provide a better view, certain photographs or illustrations in this manual may show an assembly with a safety shield removed. However, equipment should never be operated in this condition. Keep all shields in place. If shield removal becomes necessary for repairs, replace the shield prior to use.
3. Replace any safety sign or instruction sign that is not readable or is missing. Location of such safety signs is indicated in this manual.
4. Never use alcoholic beverages or drugs which can hinder alertness or coordination while operating this equipment. Consult your doctor about operating this machine while taking prescription medications.
5. **Under no circumstances should young children be allowed to work with this equipment. Do not allow persons to operate or assemble this unit until they have read this manual and have developed a thorough understanding of the safety precautions and of how it works.** Review the safety instructions with all users annually.
6. This equipment is dangerous to children and persons unfamiliar with its operation. The operator should be a responsible, properly trained and physically able person familiar with machinery and trained in this equipment's operations. If the elderly are assisting with work, their physical limitations need to be recognized and accommodated.
7. Never exceed the limits of a piece of machinery. If its ability to do a job, or to do so safely, is in question - **DON'T TRY IT.**
8. Do not modify the equipment in any way. Unauthorized modification result in serious injury or death and may impair the function and life of the equipment.
9. In addition to the design and configuration of this implement, including Safety Signs and Safety Equipment, hazard control and accident prevention are dependent upon the awareness, concern, prudence, and proper training of personnel involved in the operation, transport, maintenance, and storage of the machine. Refer also to Safety Messages and operation instruction in each of the appropriate sections of the tow vehicle, engine and machine Manuals. Pay close attention to the Safety Signs affixed to the tow vehicle and the machine.

## 2.3 SAFETY TRAINING

1. Safety is a primary concern in the design and manufacture of our products. Unfortunately, our efforts to provide safe equipment can be wiped out by a single careless act of an operator or bystander.
2. In addition to the design and configuration of equipment, hazard control and accident prevention are dependent upon the awareness, concern, prudence and proper training of personnel involved in the operation, transport, maintenance and storage of this equipment.
3. It has been said, "The best safety feature is an informed, careful operator." We ask you to be that kind of an operator. It is the operator's responsibility to read and understand ALL Safety and Operating instructions in the manual and to follow these. Accidents can be avoided.
4. Working with unfamiliar equipment can lead to careless injuries. Read this manual, and the manual for your tow vehicle, before assembly or operating, to acquaint yourself with the machines. If this machine is used by any person other than yourself, or is loaned or rented, it is the machine owner's responsibility to make certain that the operator, prior to operating:
  - a. Reads and understands the operator's manuals.
  - b. Is instructed in safe and proper use.
5. Know your controls and how to stop tow vehicle, engine, and machine quickly in an emergency. Read this manual and the one provided with your tow vehicle.
6. Train all new personnel and review instructions frequently with existing workers. Be certain only a properly trained and physically able person will operate the machinery. A person who has not read and understood all operating and safety instructions is not qualified to operate the machine. An untrained operator exposes himself and bystanders to possible serious injury or death. If the elderly are assisting with work, their physical limitations need to be recognized and accommodated.

## 2.4 SAFETY SIGNS

1. Keep safety signs clean and legible at all times.
2. Replace safety signs that are missing or have become illegible.
3. Replaced parts that displayed a safety sign should also display the current sign.
4. Safety signs are available from your authorized Distributor or Dealer Parts Department or the factory.

### How to Install Safety Signs:

- Be sure that the installation area is clean and dry.
- Be sure temperature is above 50°F (10°C).
- Determine exact position before you remove the backing paper.
- Remove the smallest portion of the split backing paper.
- Align the sign over the specified area and carefully press the small portion with the exposed sticky backing in place.
- Slowly peel back the remaining paper and carefully smooth the remaining portion of the sign in place.
- Small air pockets can be pierced with a pin and smoothed out using the piece of sign backing paper.

## 2.5 PREPARATION

1. Never operate the utility vehicle and machine until you have read and completely understand this manual, the utility Vehicle Operator's Manual, and each of the Safety Messages found on the safety signs on the tow vehicle and machine.

2. Personal protection equipment including hard hat, safety glasses, safety shoes, and gloves are recommended

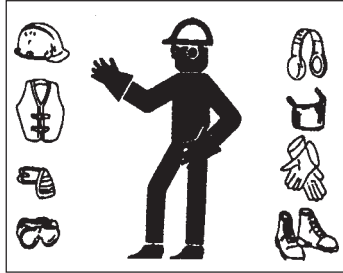

during assembly, installation, operation, adjustment, maintaining, repairing, removal, or moving the implement. Do not allow long hair, loose fitting clothing or jewelry to be around equipment.

3. **PROLONGED EXPOSURE TO LOUD NOISE MAY CAUSE PERMANENT HEARING LOSS!**

Push vehicles with or without equipment attached can often be noisy enough to cause permanent, partial hearing loss. We recommend that you wear hearing protection on a full-time basis if the noise in the Operator's position exceeds 80db. Noise over 85db on a long-term basis can cause severe hearing loss. Noise over 90db adjacent to the Operator over a long-term basis may cause permanent, total hearing loss. **NOTE:** Hearing loss from loud noise (from tractors, chain saws, radios, and other such sources close to the ear) is cumulative over a lifetime without hope of natural recovery.



4. Clear working area of stones, branches or hidden obstacles that might be hooked or snagged, causing injury or damage.
5. Operate only in daylight or good artificial light.
6. Be sure machine is properly mounted, adjusted and in good operating condition.
7. Ensure that all safety shielding and safety signs are properly installed and in good condition.

## 2.6 OPERATING SAFETY

1. Please remember it is important that you read and heed the safety signs on the Blower. Clean or replace all safety signs if they cannot be clearly read and understood. They are there for your safety, as well as the safety of others. The safe use of this machine is strictly up to you, the operator.
2. All things with moving parts are potentially hazardous. There is no substitute for a cautious, safe-minded operator who recognizes potential hazards and follows reasonable safety practices. The manufacturer has designed this Leaf Blower to be used with all its safety equipment properly attached, to minimize the chance of accidents. Study this manual to make sure you have all safety equipment attached.
3. If a safety shield or guard is removed for any reason, it must be replaced before the machine is again operated.
4. When the use of hand tools is required to perform any part of assembly, installation, adjustment, maintaining, repairing, removal, or moving, be sure the tools used are designed and recommended by the tool manufacturer for that specific task.
5. Personal protection equipment including hearing protection, hard hat, safety glasses, safety shoes, and gloves are recommended during assembly, installation, operation, adjustment, maintaining, repairing, removal, or moving. Do not allow long hair, loose fitting clothing, or jewelry to be around moving parts.
6. Always use two people to handle heavy, unwieldy components during assembly, installation, removal or moving.
7. Never place any part of your body where it would be in danger if movement should occur during assembly, installation, operation, maintaining, repairing, removal or moving.
8. Never place yourself between the push vehicle and machine while implement is in operation.
9. Place all controls in neutral, stop engine, set park brake, remove ignition key and wait for all moving parts to stop before servicing, adjusting, repairing or unplugging.
10. Use extreme care during travel. Slow down on turns and watch out for bumps.
11. Never use alcoholic beverages or drugs which can hinder alertness or coordination while operating this equipment. Consult your doctor about operating this machine while taking prescription medications.
12. Do not allow riders on the machine or push vehicle at any time. There is no safe place for any riders.
13. Before you operate the machine, check over all pins, bolts, and connections to be sure all are securely in place. Replace any damaged or worn parts immediately.
14. Do not allow anyone who is not familiar with the safety rules and operation instructions to use this machine.
15. Never allow children to operate or be around this machine.
16. Do not reach into blower openings when the engine is running. Keep others away also.
17. Clear the work area of objects which might be picked up and snagged or entangled in the machine.
18. Keep hands, feet, hair, jewelry, and clothing away from all moving and/or rotating parts.
19. Do not direct the air stream toward people, animals or buildings to prevent injury or damage.
20. Do not place hands, feet or other body parts into air stream.



## 2.7 TRANSPORT SAFETY

1. Comply with state and local laws governing highway safety and movement of machinery on public roads.
2. The use of flashing amber lights is acceptable in most localities. However, some localities prohibit their use. Local laws should be checked for all highway lighting and marking requirements.
3. At all times when driving the utility vehicle and equipment on the road or highway under 20 mph (32 kph), use flashing amber warning lights and a slow moving vehicle (SMV) identification emblem. Do not exceed 20 mph (32 kph). Reduce speed on rough roads and surfaces.
4. Plan your route to avoid heavy traffic.
5. Use a mounting pin with provisions for a retainer. Install the retainer.
6. Do not drink and drive.
7. Be a safe and courteous driver. Always yield to oncoming traffic in all situations, including narrow bridges, intersections, etc. Watch for traffic when operating near or crossing roadways.
8. Never allow riders on either push vehicle or machine.

## 2.8 STORAGE SAFETY

1. Store the unit in an area away from human activity.
2. Do not permit children to play on or around the stored machine.
3. Store the unit in a dry, level area. Support the frame with planks if required.

## 2.9 REFUELLING SAFETY

1. Handle fuel with care. It is highly flammable.
2. Allow engine to cool for 5 minutes before refuelling. Clean up spilled fuel before restarting engine.
3. Do not refuel the machine while smoking or when near open flame or sparks.
4. Fill fuel tank outdoors.
5. Prevent fires by keeping machine clean of accumulated trash, grease and debris.



## 2.10 TIRE SAFETY

1. Failure to follow proper procedures when mounting a tire on a wheel or rim can produce an explosion which may result in serious injury or death.
2. Do not attempt to mount a tire unless you have the proper equipment and experience to do the job.
3. Have a qualified tire dealer or repair service perform required tire maintenance.
4. When replacing worn tires, make sure they meet the original tire specifications. Never undersize.



## 2.11 MAINTENANCE SAFETY

1. Good maintenance is your responsibility. Poor maintenance is an invitation to trouble.
2. Follow good shop practices.

- Keep service area clean and dry.
- Be sure electrical outlets and tools are properly grounded.
- Use adequate light for the job at hand.



3. Make sure there is plenty of ventilation. Never operate an engine in a closed building. The exhaust fumes may cause asphyxiation.
4. Before working on this machine, shut off the engine, set the brakes, and remove the ignition keys.
6. Never work under equipment unless it is blocked securely.
7. Always use personal protection devices such as eye, hand and hearing protectors, when performing any service or maintenance work.
8. Where replacement parts are necessary for periodic maintenance and servicing, genuine factory replacement parts must be used to restore your equipment to original specifications. The manufacturer will not be responsible for injuries or damages caused by use of unapproved parts and/or accessories.

9. A fire extinguisher and first aid kit should be kept readily accessible while performing maintenance on this equipment.

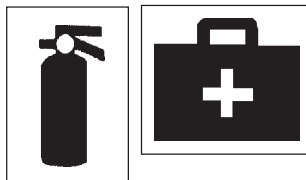

10. Periodically tighten all bolts, nuts and screws and check that all cotter pins are properly installed to ensure unit is in a safe condition.
11. When completing a maintenance or service function, make sure all safety shields and devices are installed before placing unit in service.

## 2.12 BATTERY SAFETY

1. Keep all sparks and flames away from batteries, as gas given off by electrolyte is explosive.
2. Avoid contact with battery electrolyte: wash off any spilled electrolyte immediately.
3. Wear safety glasses when working near batteries.
4. Do not tip batteries more than 45 degrees, to avoid electrolyte loss.
5. To avoid injury from spark or short circuit, disconnect battery ground cable before servicing any part of electrical system.

## 2.13 GAS MOTOR SAFETY

**BEFORE STARTING ENGINE, READ AND UNDERSTAND THE OPERATING AND MAINTENANCE INSTRUCTIONS THAT CAME WITH YOUR ENGINE.**

**WARNING: DO NOT**

1. DO NOT run engine in an enclosed area. Exhaust gases contain carbon monoxide, an odorless and deadly poison.
2. DO NOT place hands or feet near moving or rotating parts.
3. DO NOT store, spill, or use gasoline near an open flame, or devices such as a stove, furnace, or water heater which use a pilot light or devices which can create a spark.
4. DO NOT refuel indoors where area is not well ventilated. Outdoor refuelling is preferred.
5. DO NOT fill fuel tank while engine is running. Allow engine to cool for 5 minutes before refuelling. Store fuel in approved safety containers.
6. DO NOT remove fuel tank cap while engine is running.
7. DO NOT operate engine if gasoline is spilled. Move machine away from the spill and avoid creating any ignition until the gasoline has evaporated.
8. DO NOT smoke when filling fuel tank.
9. DO NOT choke carburetor to stop engine. Whenever possible, gradually reduce engine speed before stopping.
10. DO NOT run engine above rated speeds. This may result in injury.
11. DO NOT tamper with governor springs, governor links or other parts which may increase the governed engine speed.
12. DO NOT tamper with the engine speed selected by the original equipment manufacturer.
13. DO NOT check for spark with spark plug or spark plug wire removed. Use an approved tester.
14. DO NOT crank engine with spark plug re-

moved. If engine is flooded, place throttle in "FAST" position and crank until engine starts.

15. DO NOT strike flywheel with a hard object or metal tool as this may cause flywheel to shatter in operation. Use proper tools to service engine.
16. DO NOT operate engine without a muffler. Inspect periodically and replace, if necessary. If engine is equipped with muffler deflector, inspect periodically and replace, if necessary with correct deflector.
17. DO NOT operate engine with an accumulation of grass, leaves, dirt or other combustible materials in the muffler area.
18. DO NOT use this engine on any forest covered, brush covered, or grass covered unimproved land unless a spark arrester is installed on the muffler. The arrester must be maintained in effective working order by the operator. In the State of California the above is required by law (Section 4442 of the California Public Resources Code). Other states may have similar laws. Federal laws apply on federal lands.
19. DO NOT touch hot muffler, cylinder or fins because contact may cause burns.
20. DO NOT run engine with air cleaner or air cleaner cover removed.

**WARNING: DO**

1. ALWAYS DO remove the wire from the spark plug when servicing the engine or equipment TO PREVENT ACCIDENTAL STARTING or disconnect the negative wire from the battery terminal.
2. DO keep cylinder fins and governor parts free of grass and other debris which can affect engine speed.
3. DO examine muffler periodically to be sure it is functioning effectively. A worn or leaking muffler should be repaired or replaced as necessary.
4. DO use fresh gasoline. Stale fuel can gum carburetor and cause leakage.
5. DO check fuel lines and fittings frequently for cracks or leaks. Replace if necessary.
6. DO check air filter periodically.

## 2.14 SIGN-OFF FORM

AgriMetal follows the general Safety Standards specified by the American Society of Agricultural Engineers (ASAE) and the Occupational Safety and Health Administration (OSHA). Anyone who will be operating and/or maintaining the Front mount Leaf Blower must read and clearly understand ALL Safety, Operating and Maintenance information presented in this manual.

Do not operate or allow anyone else to operate this equipment until such information has been reviewed. Annually review this information before the season start-up.

Make these periodic reviews of SAFETY and OPERATION a standard practice for all of your equipment. We feel that an untrained operator is unqualified to operate this machine.

A sign-off sheet is provided for your record keeping to show that all personnel who will be working with the equipment have read and understand the information in the Operator's Manual and have been instructed in the operation of the equipment.

### SIGN-OFF FORM

DATE	EMPLOYEES SIGNATURE	EMPLOYERS SIGNATURE



### 3 SAFETY SIGN LOCATIONS

The types of safety signs and locations on the equipment are shown in the illustrations that follow. Good safety requires that you familiarize yourself with the various safety signs, the type of warning and the area, or particular function related to that area, that requires your SAFETY AWARENESS.

- Think SAFETY! Work SAFELY!



A

 <b>CAUTION</b>	 <b>ATTENTION</b>
<ol style="list-style-type: none"><li>1. Read Operator's Manual before starting.</li><li>2. Keep guards and shields in place and access doors closed.</li><li>3. Keep hands, feet, hair and clothing away from moving parts.</li><li>4. Stop engine, place all controls in neutral, set park brake, remove ignition key and wait for all moving parts to stop before servicing, adjusting, repairing or unplugging the machine.</li><li>5. Do not climb on the machine or place hands in any opening when the engine is running.</li><li>6. Keep people and pets a safe distance from the machine.</li><li>7. Do not smoke when refuelling.</li><li>8. Block up machine securely before working under it.</li><li>9. Keep all electrical wires and connections dry and in good repair.</li><li>10. Do not direct discharge duct or hose toward people, animals or property to prevent being hit by fast moving objects. Always wear appropriate safety gear during operation.</li><li>11. Review safety instructions annually.</li></ol>	<ol style="list-style-type: none"><li>1. Lire attentivement le manuel d'opération avant la mise en marche.</li><li>2. Garder tous les écrans protecteurs in place.</li><li>3. Garder les mains, pieds, cheveux et vêtements éloignés des éléments mobiles.</li><li>4. Arrêter le moteur, placer tous les contrôles à la position "neutre", enlever la clé du contact et attendre que toutes les places soient au point mort avant de faire tout ajustement, réparation ou de débloquer la machine.</li><li>5. Ne pas grimper sur la machine et ne jamais se placer les mains dans toute ouverture lorsque celle-ci est en marche.</li><li>6. Garder les gens et les animaux à une distance sécuritaire de la machine.</li><li>7. Ne jamais fumer lors du plein d'essence.</li><li>8. Immobiliser la machine de façon sécuritaire avant de travailler sous celle-ci.</li><li>9. Garder toute connection et fil électrique au sec et en bonne condition.</li><li>10. Afin d'éviter tout risque d'accident grave, ne jamais souffler en direction des gens, animaux ou vers les propriétés. Le port des équipements de sécurité est obligatoire lorsque vous opérerez la machine.</li><li>11. Reviser annuellement le manual d'opération.</li></ol>

NC13-33-0108



REMEMBER - If safety signs have been damaged, removed, become illegible or parts replaced without safety signs, new signs must be applied. New safety signs are available from your authorized dealer.

The types of safety signs and locations on the equipment are shown in the illustrations that follow. Good safety requires that you familiarize yourself with the various safety signs, the type of warning and the area, or particular function related to that area, that requires your SAFETY AWARENESS.

- Think SAFETY! Work SAFELY!



B



 <b>DANGER</b>	
	
<p><b>FIRE HAZARD NO SMOKING</b></p> <p>To prevent serious injury or death from fire:</p> <ol style="list-style-type: none"><li>1. Do not smoke when refueling.</li><li>2. Keep sparks, flames and hot material away from flammable substances.</li><li>3. Stop engine five minutes before refueling.</li></ol>	<p><b>RISQUE D'INCENDIE DEFENSE DE FUMER</b></p> <p>À défaut de suivre ces instructions, cela pourrait entraîner de sérieuses blessures ou même la mort.</p> <ol style="list-style-type: none"><li>1. Ne pas fumer lors du remplissage.</li><li>2. Garder les flammes et toute matière inflammable hors de portée.</li><li>3. Arrêter le moteur cinq minutes avant de refaire le plein.</li></ol> <p>01-60-0060</p>

REMEMBER - If safety signs have been damaged, removed, become illegible or parts replaced without safety signs, new signs must be applied. New safety signs are available from your authorized dealer.

The types of safety signs and locations on the equipment are shown in the illustrations that follow. Good safety requires that you familiarize yourself with the various safety signs, the type of warning and the area, or particular function related to that area, that requires your SAFETY AWARENESS.

- Think SAFETY! Work SAFELY!

C

 <b>DANGER</b>	
	
<p><b>THROWN OBJECT HAZARD</b>  <b>To prevent serious injury or death from a thrown object:</b></p> <ol style="list-style-type: none"> <li>1. Stop engine, place all controls in neutral, set park brake, remove ignition key and wait for all moving parts to stop before servicing, adjusting, repairing or unplugging machine.</li> <li>2. Do not direct discharge duct toward people, animals or property. Always wear appropriate safety gear. Keep hands and feet out of discharge openings.</li> <li>3. Keep others away.</li> </ol>	<p><b>RISQUE D'OBJETS PROJÉTÉS</b>  <b>À défaut de suivre ces instructions, cela pourrait entraîner de sérieuses blessures ou même la mort.</b></p> <ol style="list-style-type: none"> <li>1. Arrêter le moteur, placer tous les contrôles à la position "neutre", enlever la clé du contact et attendre que toutes les places soient au point mort avant de faire tout ajustement, réparation ou de débloquer la machine.</li> <li>2. Afin d'éviter tout risque d'accident grave, ne jamais souffler en direction des gens, des animaux ou vers les propriétés. Le port des équipements de sécurité est obligatoire lorsque vous opérez la machine.</li> <li>3. Garder les gens éloignés de la machine.</li> </ol> <p style="text-align: right; font-size: small;">NC13-33-0110</p>

**REMEMBER** - If safety signs have been damaged, removed, become illegible or parts replaced without safety signs, new signs must be applied. New safety signs are available from your authorized dealer.



## 4 ASSEMBLING

### 4.1 MACHINE ASSEMBLY

The machine is shipped from the factory in a partially disassembled configuration and attached to a pallet that provides for easy moving and handling. Always use tools, equipment and forklifts of appropriate size and capacity for the job. Always use 2 men when lifting, moving and assembling the machine.

**When the machine is shipped, follow this procedure when preparing for the customer:**

1. Clear the area of bystanders especially small children before starting.
2. Remove the pallet tie-downs.



**Wrapped**



**Unwrapped**

**Fig. 1 SHIPPING CONFIGURATION**



- 3. Use a forklift to lift the pallet/machine from the truck. Carry the load close to the ground as it is moved to the assembly area and positioned.
- 4. Remove plastic wrap.
- 5. Cut strapping and remove screws holding components to pallet.



**Strapping**



**Screws**

**Fig. 2 LOOSENING**

- 6. Lay out components.



**Fig. 3 LAYOUT**

7. Mount the control cable stand.
  - a. Remove the nuts from the stand rod.



**Removal**

- b. Mount the rod into the frame and install the nuts.

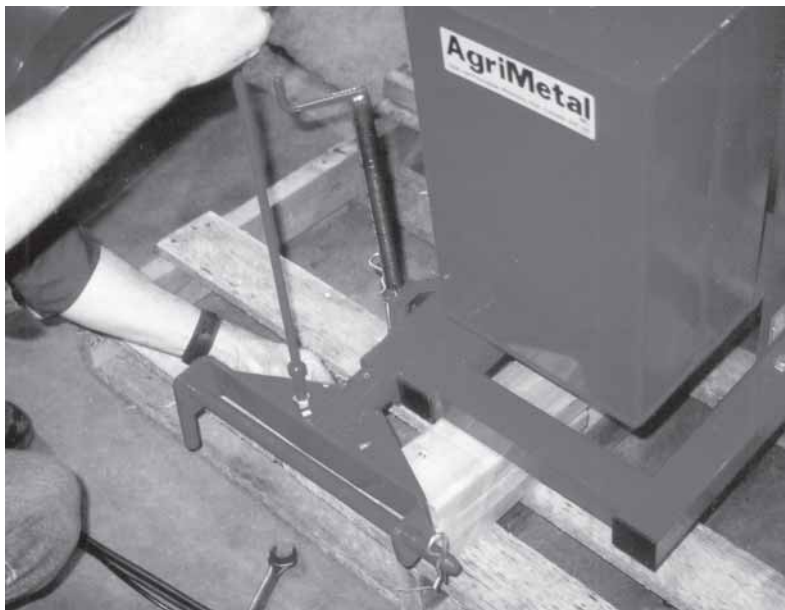

**Installation**

- c. Tighten nuts to their specified torque.

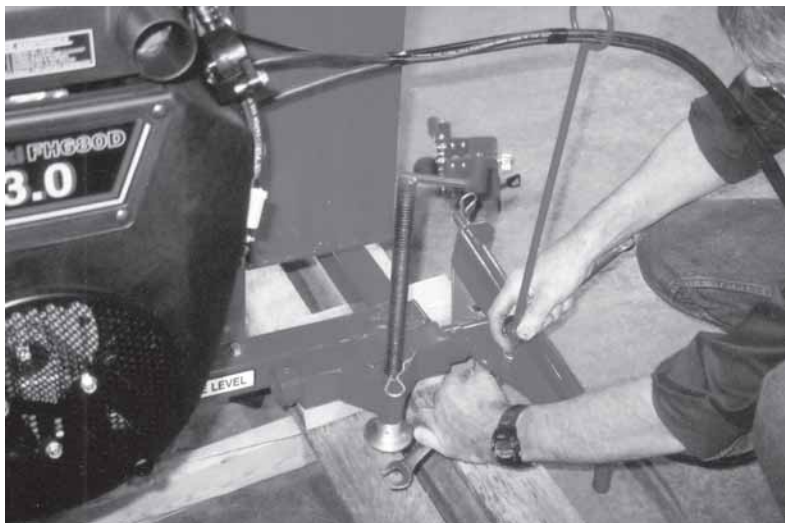

**Tightening**

**Fig. 4 CONTROL CABLE STAND**

8. Wrap the control module and cable back over the frame.
9. Use a forklift crane or hoist to lift the machine and back away from the pallet or slide it out of the way.



**Fig. 5 PALLET REMOVAL**

10. Lower the jack and set the machine on the working surface.

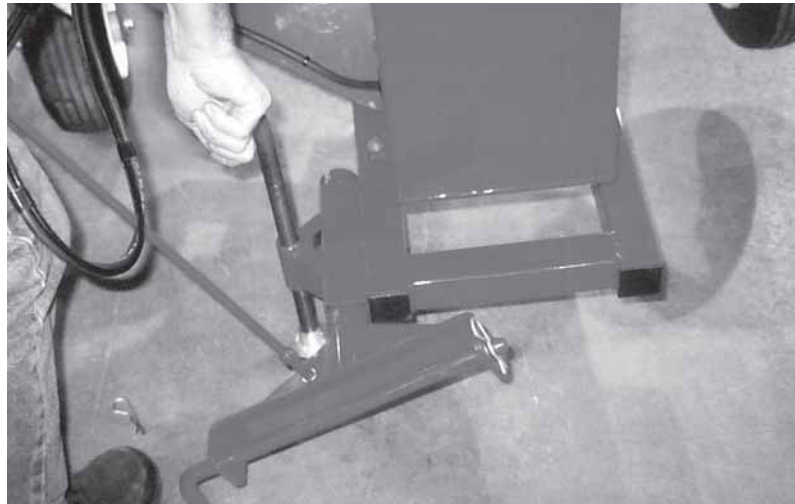

**Jack**



**Placement**

**Fig. 6 WORKING AREA**

11. Mount the deflector to the discharge outlet. Be sure to align arrows when mounting.
12. Tighten fasteners to their specified torque.

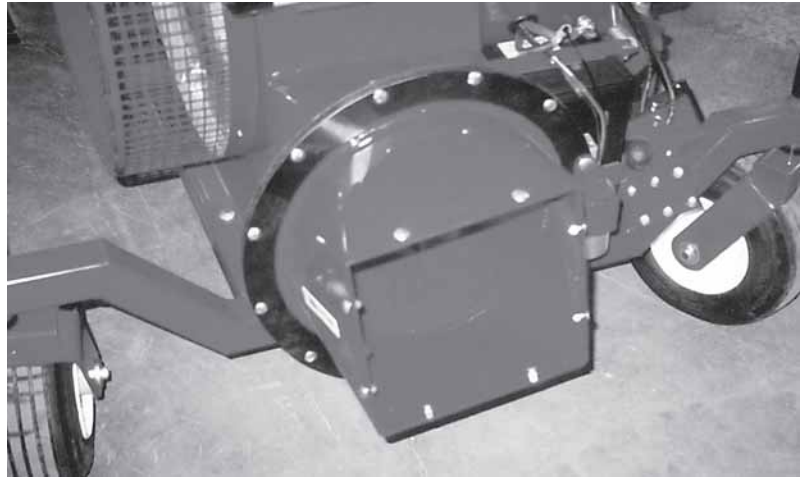

**Fastener Removal**



**Arrows**

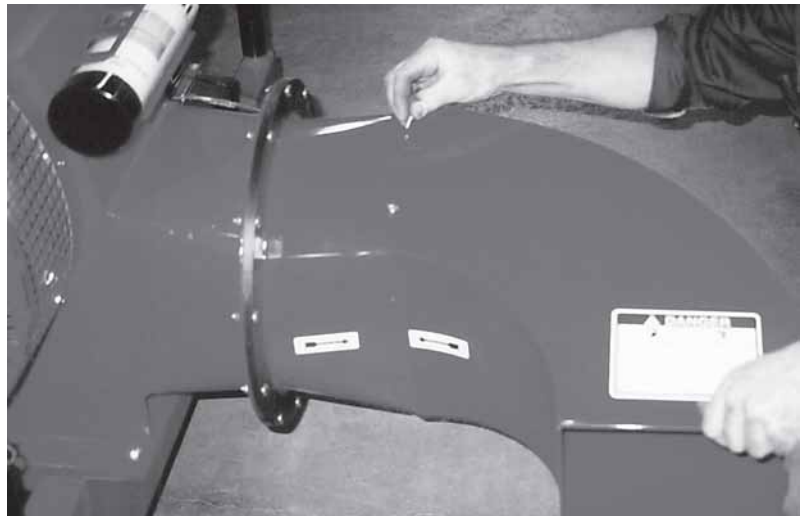

**Installing**

**Fig. 7 DEFLECTOR**



13. Connect the battery cables and tighten fasteners to their specified torque.

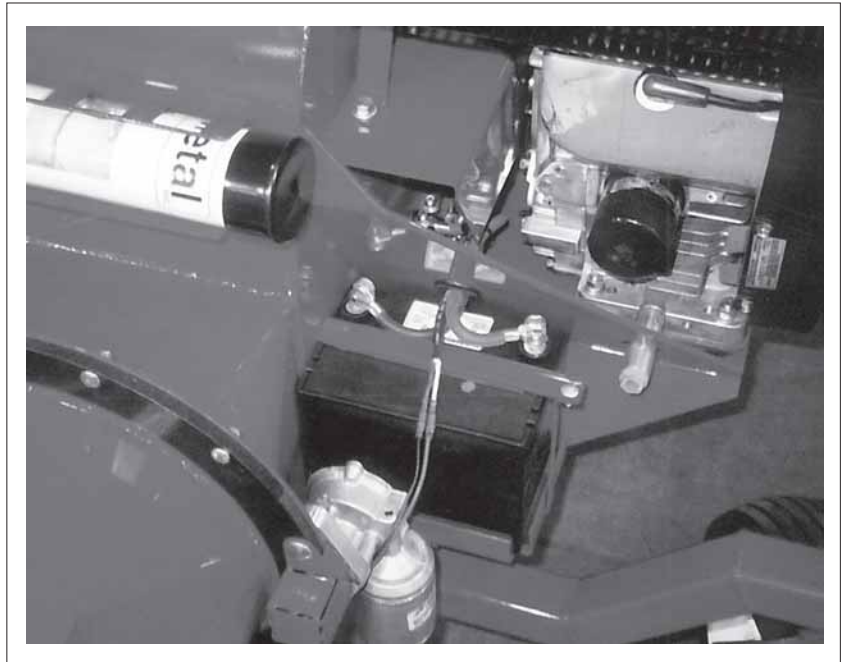

**Fig. 8 BATTERY CABLE**

## 5 OPERATION



### OPERATING SAFETY

- Please remember it is important that you read and heed the safety signs on the Leaf Blower. Clean or replace all safety signs if they cannot be clearly read and understood.
- If a safety shield or guard is removed for any reason, it must be replaced before the machine is again operated.
- Always use two people to handle heavy, unwieldy components during assembly, installation, removal or moving.
- Place all controls in neutral, stop engine, set park brake, remove ignition key and wait for all moving parts to stop before servicing, adjusting, repairing or unplugging.
- Do not allow riders on the machine or push vehicle at any time. There is no safe place for any riders.
- Do not allow anyone who is not familiar with the safety rules and operation instructions to use this machine.
- Never allow children to operate or be around this machine.
- Do not reach into blower openings when the engine is running. Clear the work area of objects which might be picked up and snagged or entangled in the machine.
- Clear the work area of objects which might be picked up and snagged or entangled in the machine.
- Do not reach into blower openings when the engine is running. Keep others away also.
- Keep hands, feet, hair, jewelry, and clothing away from all moving and/or rotating parts.
- Do not direct the air stream toward people, animals or buildings to prevent injury or damage.
- Do not place hands, feet or other body parts into air stream.

### 5.1 TO THE NEW OPERATOR OR OWNER

AgriMetal Front mount Leaf Blowers are designed to quickly and efficiently, blow away leaves, cuttings and other debris. The material is conveyed on a stream of high velocity air to remove it from the area of concern. When the material is removed, it gives a neat, professional look to the working area.

**In addition to the design and configuration of equipment, hazard control and accident prevention are dependent upon the awareness, concern, prudence and proper training of personnel involved in the operation, transport, maintenance and storage of equipment. It is the responsibility of the owner or operator to read this manual and to train all other operators before they start working with the machine.**

**Follow all safety instructions exactly. Safety is everyone's business. By following recommended procedures, a safe working environment is provided for the operator, bystanders and the area around the worksite. Untrained operators are not qualified to operate the machine.**

Many features incorporated into this machine are the result of suggestions made by customers like you. Read this manual carefully to learn how to operate the machine safely and how to set it to provide maximum field efficiency. By following the operating instructions in conjunction with a good maintenance program, your Front mount Leaf Blower will provide many years of trouble-free service.

## 5.2 MACHINE COMPONENTS

The AgriMetal Front mount Leaf Blower is a large blower mounted on a trailer for moving debris on a stream of air. The air stream can be directed to the right, left or down depending on the duct position. A gas engine on the front frame powers the blower. The throttle and duct position controls are located on an umbilical cord that extends to the pushing vehicle. An electric solenoid moves the duct to the desired position.

Adapters for mounting to John Deere, Kubota and Toro garden equipment is available.

- A Discharge Duct
- B Duct Position Control
- C Blower
- D Gas Engine
- E Throttle Control
- F Duct Position Drive
- G Umbilical Cord
- H Blower Air Intake



Fig. 9 PRINCIPLE COMPONENTS



## 5.3 BREAK-IN

Although there are no operational restrictions on the Blower when it is used for the first time, it is recommended that the following mechanical items be checked:

### A. After operating for 1 hour:

1. Torque all fasteners and hardware.
2. Check condition of blower bearings.
3. Check tire pressure. Inflate as required.
4. Check engine fluid levels. Top up as required.

### B. After operating for 10 hours:

1. Repeat steps 1 through 4 listed above. (Section A).
2. Change engine oil.
3. Go to the normal servicing and maintenance schedule as defined in the Maintenance Section.

## 5.4 PRE-OPERATION CHECKLIST

Efficient and safe operation of the AgriMetal Front mount Leaf Blower requires that each operator reads and understands the operating procedures and all related safety precautions outlined in this section. A pre-operation checklist is provided for the operator. It is important for both personal safety and for maintaining the machine in good mechanical condition that this checklist be followed.

Before operating the Blower and each time thereafter, the following areas should be checked off:

1. Lubricate the machine per the schedule outline in the Maintenance Section.
2. Check that all bearings turn freely. Replace any that are rough or seized.
3. Make sure that all guards and shields are in place, secured and functioning as designed.
4. Clean the screen over the blower intake.
5. Check engine oil and fuel level. Top up as required.

## 5.5 CONTROLS

Before starting to work, all operators should familiarize themselves with the location and function of the controls.

### 1. Gas Engine:

Read the engine manufacturers operator's manual before starting for more detailed instructions.

#### a. Ignition Switch:

This key operated switch controls the electric power to the engine.

**OFF** - Turn the key fully counterclockwise to stop the fuel flow and turn the engine off.

**RUN** - Turn clockwise on detent to the run position. This is the position where the engine will continue to run.

**START** - Turn fully clockwise to the last spring-loaded detent position to engage the starter solenoid and start the engine. Release the key when the engine starts and it will return to the RUN position.

#### b. Choke:

This wire loop controls the position of the choke. Push the loop in to close the choke for starting when the engine is cold. Pull the loop out to open the choke as the engine warms. Always pull the loop fully out when operating the machine.

### 2. Control Module:

Each machine is equipped with a remote control module that attaches to the power unit. Be familiar with each control before starting.

#### a. Rotary Switch:

This rotary switch controls the power to the duct position actuator. Turn the switch to the right and hold to move the center duct to the right. Turn and hold to the left to move the center duct to the left. Release the switch and the center duct will stop moving.

### NOTE

Watch the position of the duct to determine its position.

#### b. Throttle:

This lever controls the throttle position on the gas engine through a push-pull cable. Move the lever toward the cable to increase engine RPM and away to decrease.



Fig. 10 IGNITION SWITCH

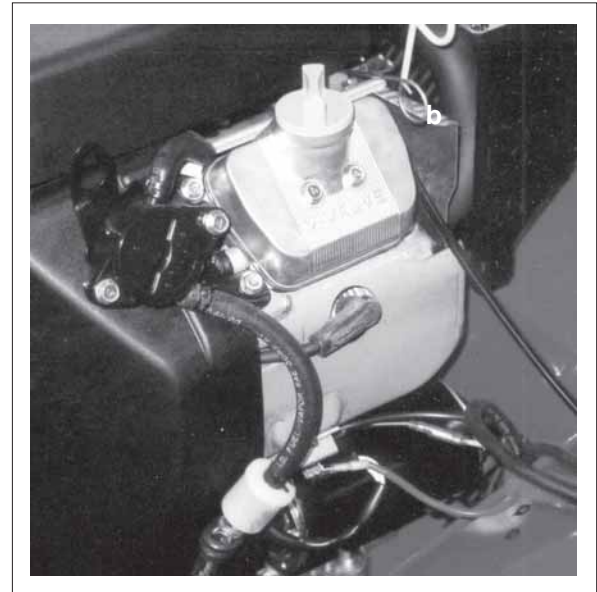

Fig. 11 CHOKE



Fig. 12 CONTROL MODULE

## 5.6 ATTACHING/UNHOOKING

The Blower is designed to be used on John Deere Gators and Turf TX, Toro Twister and Kubota RTV 900 power units in a push mode. Each must be configured to accept the mounting bracket.

### 5.6.1 JOHN DEERE GATOR AND TURF TX

To attach the JD Gator or Turf TX, follow this procedure:

1. Clear the area of bystanders, especially small children.
2. Place all controls in neutral, set park brake, remove ignition key and wait for all moving parts to stop.
3. Remove the front bumper from the power unit.

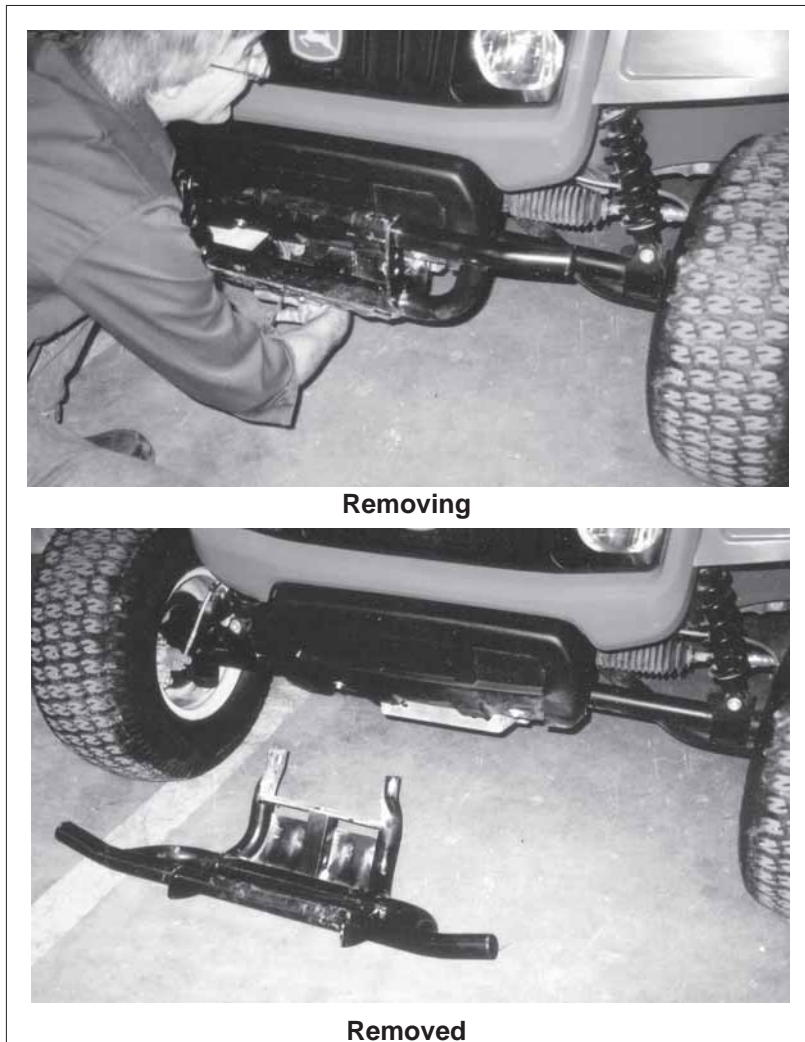
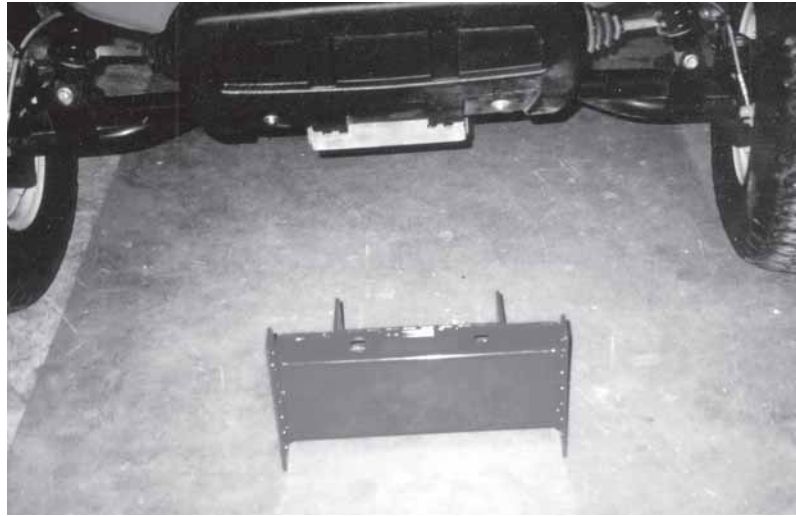

Fig. 13 FRONT BUMPER REMOVAL

4. Install the mounting bracket to the front of the power unit.
5. Tighten fasteners to their specified torque.



**Lay-Out**



**Installing**

**Fig. 14 BRACKET INSTALLATION**

6. **Attach the power unit to the blower:**

a. Move the power unit up to the blower.



**Aligning**

b. Remove the mounting pin retainer and mounting pin.

c. Move power unit ahead and align holes.



**Installing**

d. Install mounting pin and retainer.



**Retainer**

**Fig. 15 ATTACHING**

7. Raise jack.
8. Level frame.



**Fig. 16 JACK**



9. Mount the control module to the power unit:

a. Remove fasteners from the control bracket.



**Fasteners**

b. Mount bracket to handhold.



**Mounting**

c. Mount control module to bracket.



**Module**

e. Tighten all fasteners to their specified torque.



**Mounted**

**Fig. 17 CONTROL MODULE**



10. Route the control cable over the hood and secure through the cable bracket ring.

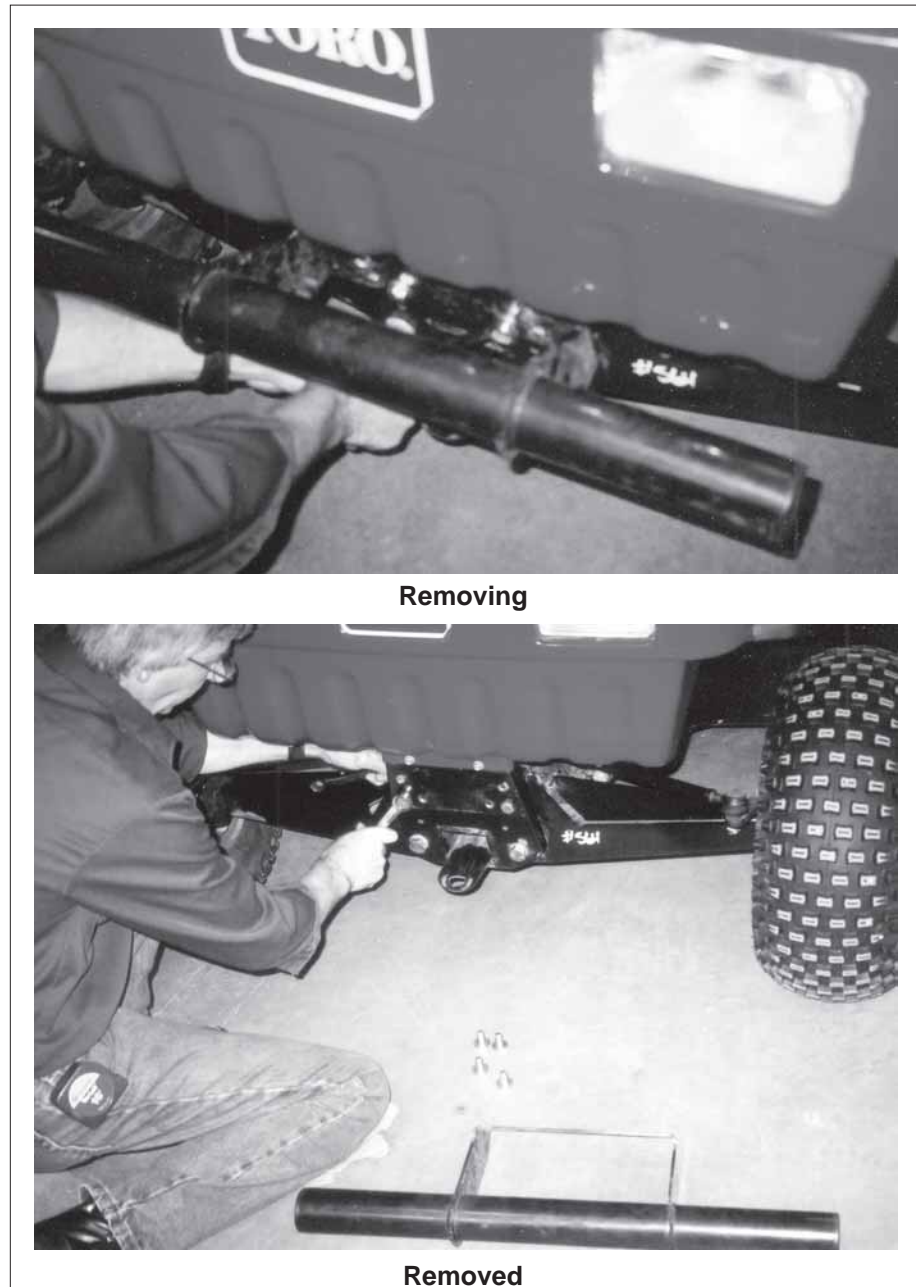

**Fig. 18 ROUTING**

## 5.6.2 TORO TWISTER

To attach the Toro Twister, follow this procedure:

1. Clear the area of bystanders, especially small children.
2. Place all controls in neutral, set park brake, remove ignition key and wait for all moving parts to stop.
3. Remove the front bumper from the power unit.



**Fig. 19 FRONT BUMPER REMOVAL**

4. Install the mounting bracket to the front of the power unit.
5. Tighten fasteners to their specified torque.



**Lay-Out**



**Installing**

**Fig. 20 BRACKET INSTALLATION**

6. **Attach the power unit to the blower:**

a. Move the power unit up to the blower.



**Aligning**

b. Remove the mounting pin retainer and mounting pin.

c. Move power unit ahead and align holes.

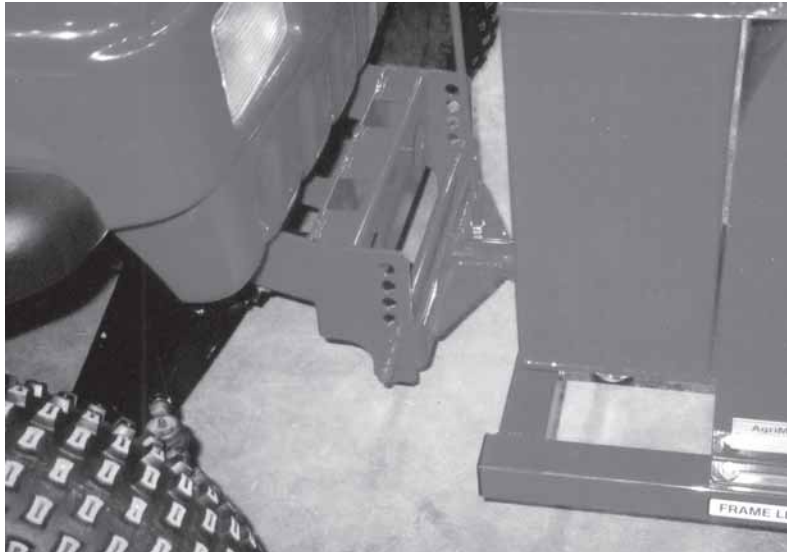

**Installing**

d. Install mounting pin and retainer.

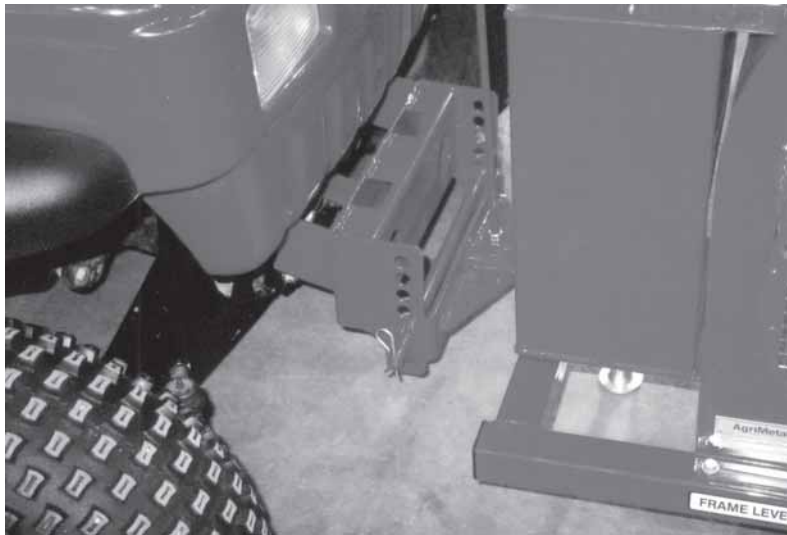

**Retainer**

**Fig. 21 ATTACHING**

7. Raise jack.
8. Level frame.



**Fig. 22 JACK**

9. Mount the control module to the power unit:
  - a. Remove fastener from the control bracket.
  - b. Install bracket into dash pocket.



**Dash Pocket**

- c. Mount control module to bracket.

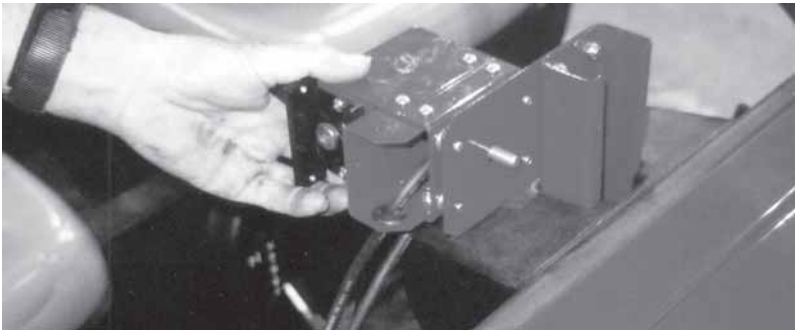

**Module**

- d. Secure module with knob.
      - e. Tighten all fasteners to their specified torque.



**Mounted**

**Fig. 23 CONTROL MODULE**

10. Route the control cable over the hood and through the cable bracket ring.

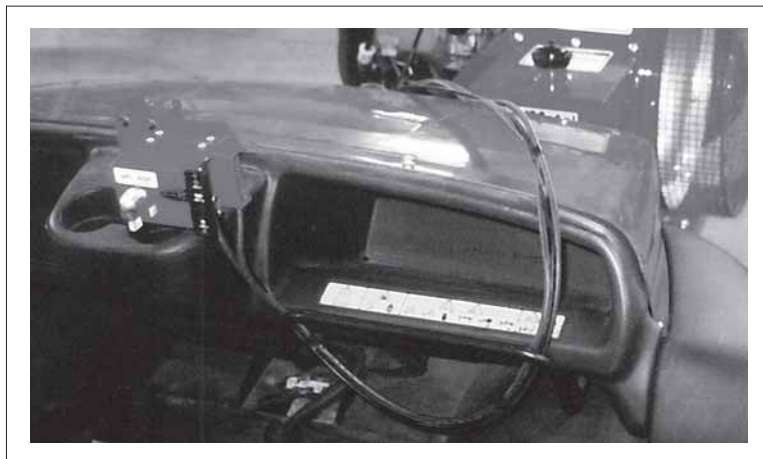

**Fig. 24 ROUTING**



### 5.6.3 KUBOTA RTV 900

To attach the Kubota RTV 900, follow this procedure:

1. Clear the area of bystanders, especially small children.
2. Place all controls in neutral, set park brake, remove ignition key and wait for all moving parts to stop.
3. Remove the low front bumper from the power unit.



**Low Bumper**



**Removing**

**Fig. 25 FRONT BUMPER REMOVAL**



4. Install the mounting bracket to the front of the power unit.

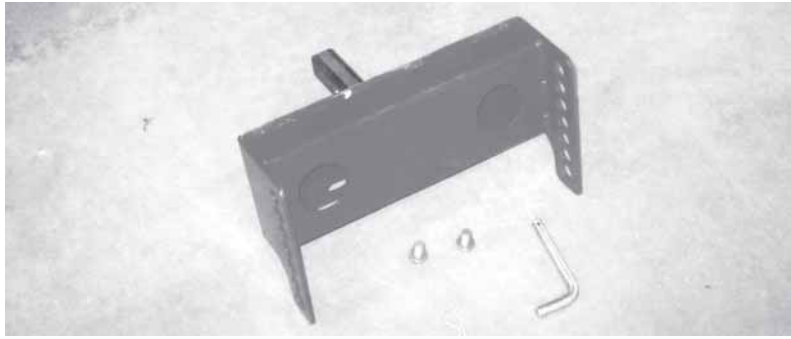

**Lay-Out**



**Mounting**

5. Tighten fasteners to their specified torque.



**Fasteners**

6. Install the lock pin and retainer.



**Lock Pin**

**Fig. 26 BRACKET INSTALLATION**

7. Remove the high front bumper fasteners from the power unit.



**Front Bumper**



**Removing**

**Fig. 27 FRONT BUMPER**

8. Install the mounting bracket to the front of the power unit.
  - a. Slide the bracket into the pocket.



**Lay-Out**

- b. Install spacers on each end of bracket.



**Installing**



**Spacer**

- c. Tighten fasteners to their specified torque.



**Tightening**

**Fig. 28 BRACKET INSTALLATION**

9. Install anchor pin and re-  
tainer.

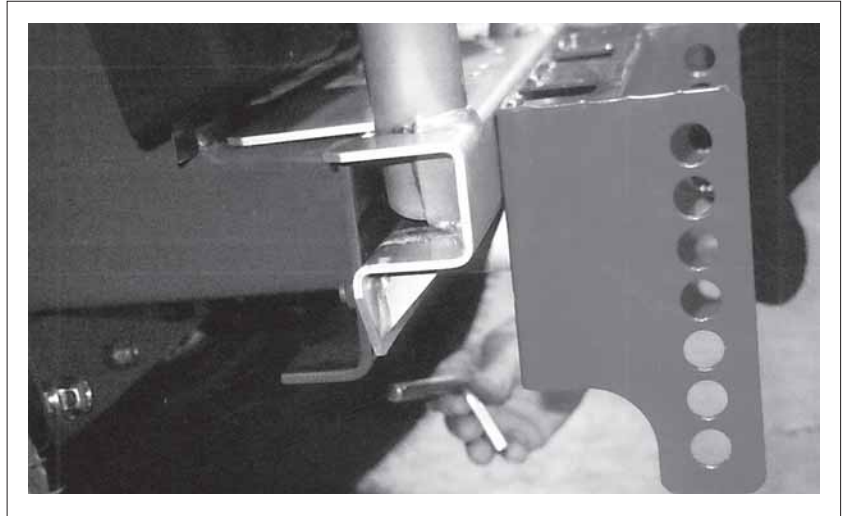

**Fig. 29 ANCHOR PIN**

10. **Attach the power unit to the blower:**

a. Move the power unit up to the blower.

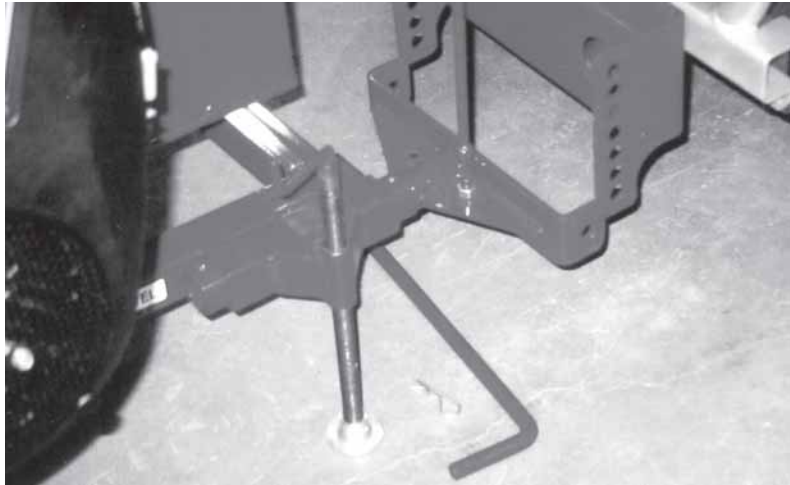

**Aligning**

b. Remove the mounting pin retainer and mounting pin.

c. Move power unit ahead and align holes.

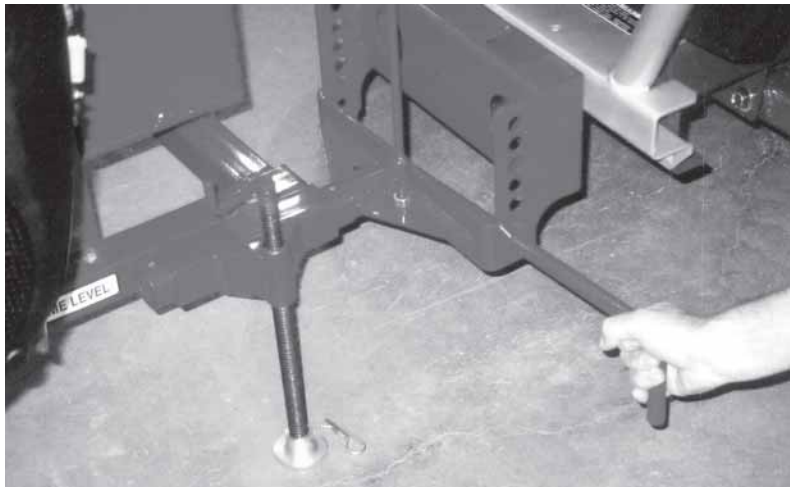

**Installing**

d. Install mounting pin and retainer.



**Retainer**

**Fig. 30 ATTACHING**

11. Raise jack.



**Fig. 31 JACK**

12. Level frame.

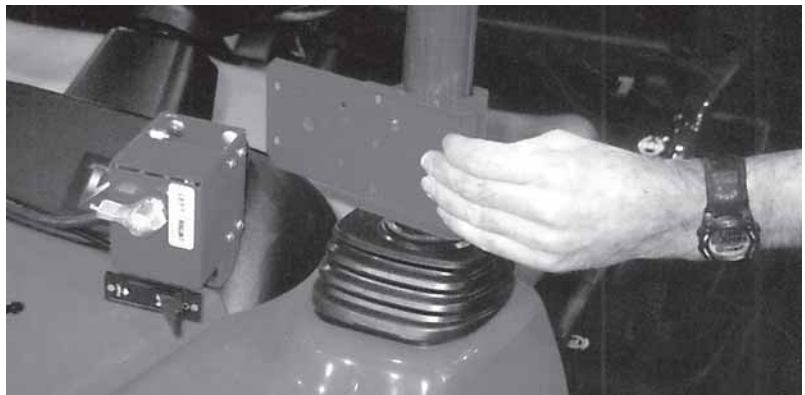

**Fig. 32 LEVEL FRAME**



13. Mount the control module to the power unit:

- a. Remove fastener from the control bracket.
- b. Mount bracket to cab frame.



**Fasteners**

- c. Mount control module to bracket.

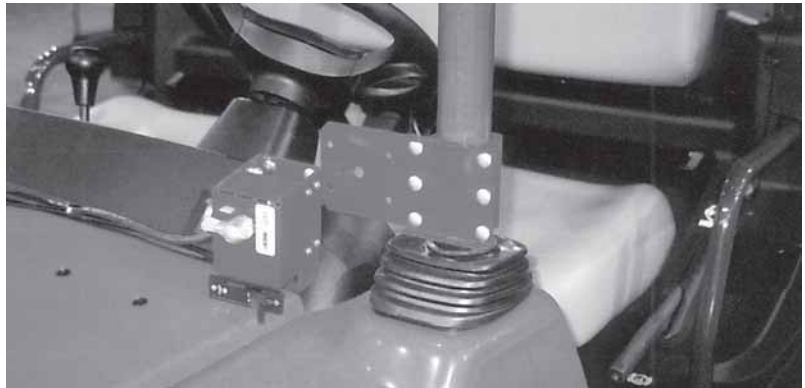

**Mounting**

- d. Secure module with knob.



**Module**

- e. Tighten all fasteners to their specified torque.



**Mounted**

**Fig. 33 CONTROL MODULE**

14. Route the control cable over the hood and through the cable bracket ring.



**Fig. 34 ROUTING**

## 5.7 FIELD OPERATION



### OPERATING SAFETY

- Please remember it is important that you read and heed the safety signs on the Leaf Blower. Clean or replace all safety signs if they cannot be clearly read and understood.
- If a safety shield or guard is removed for any reason, it must be replaced before the machine is again operated.
- Always use two people to handle heavy, unwieldy components during assembly, installation, removal or moving.
- Place all controls in neutral, stop engine, set park brake, remove ignition key and wait for all moving parts to stop before servicing, adjusting, repairing or unplugging.
- Do not allow riders on the machine or push vehicle at any time. There is no safe place for any riders.
- Do not allow anyone who is not familiar with the safety rules and operation instructions to use this machine.
- Never allow children to operate or be around this machine.
- Do not reach into blower openings when the engine is running. Clear the work area of objects which might be picked up and snagged or entangled in the machine.
- Clear the work area of objects which might be picked up and snagged or entangled in the machine.
- Do not reach into blower openings when the engine is running. Keep others away also.
- Keep hands, feet, hair, jewelry, and clothing away from all moving and/or rotating parts.
- Do not direct the air stream toward people, animals or buildings to prevent injury or damage.
- Do not place hands, feet or other body parts into air stream.

Although the Leaf Blower is easy to use, each operator should review this section to familiarize himself with the detailed safety and operating procedures. When using the machine, follow this procedure:

1. Clear the area of bystanders, especially small children.
2. Review and follow the Pre-Operation Checklist (see Section 5.4).
3. Attach the machine to the push vehicle (see Section 5.6). Be sure the frame is level.
4. Transport to the working area (refer to Section 5.8).

5. **Starting Machine:**

- a. Stop utility vehicle engine, set park brake, remove ignition key and wait for all moving parts to stop before dismounting.
- c. Close the choke if the engine is cold.
- d. Move the throttle to its 1/4 throttle position.
- e. Use the ignition switch on the front frame to start the engine.
- f. Run the engine for a few minutes to allow it to warm.
- g. Gradually open the choke.
- h. Increase throttle setting to maximum speed for operation.
- i. Start push vehicle engine to start working.

6. Use the rotary switch to set the position of the center duct.

7. **Travel Speed:**

Set the travel speed appropriate for the job being done. Travel faster if all the debris is being blown away. Slow down if some debris is not being removed.

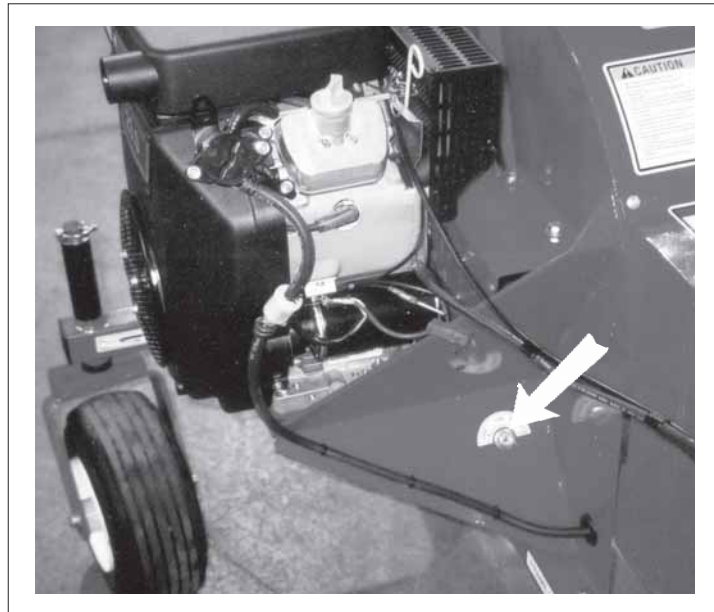

Fig. 35 IGNITION SWITCH



To Left



To Right

Fig. 36 WORKING

8. **Center Duct:**

The Blower is designed with a moveable center duct that can be used to direct the air to the left, or right. Use the spring-loaded rotary switch on the control module to change the duct position.

**NOTE**

The machine ignition switch must be in the run position when moving the center duct.



**Control**



**Left**



**Right**

**Fig. 37 DUCT POSITION**



9. **Castor Wheel Height:**

- a. The castor shaft on the wheels can be set in the high, middle or low position to fit any application. Each machine is shipped from the factory with the shafts in the high position. Refer to Maintenance section for conversion procedure.

**NOTE**

It may be necessary to change hitch configuration when axle height changes to keep the hitch/frame level.

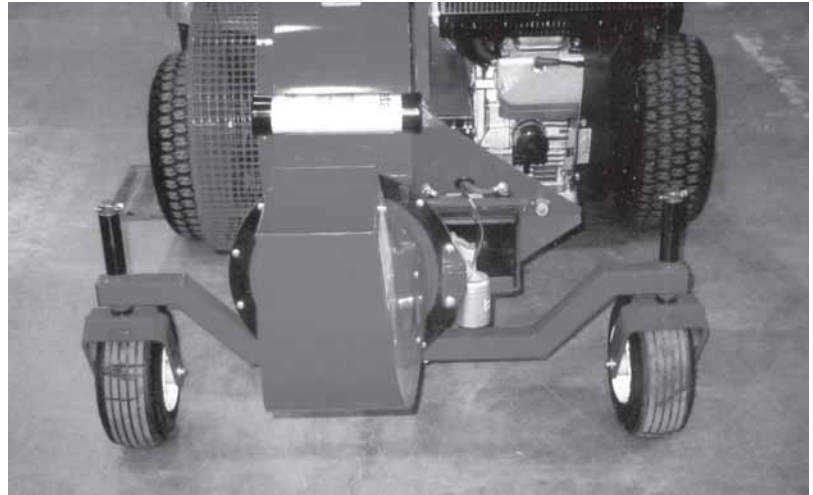

**High**

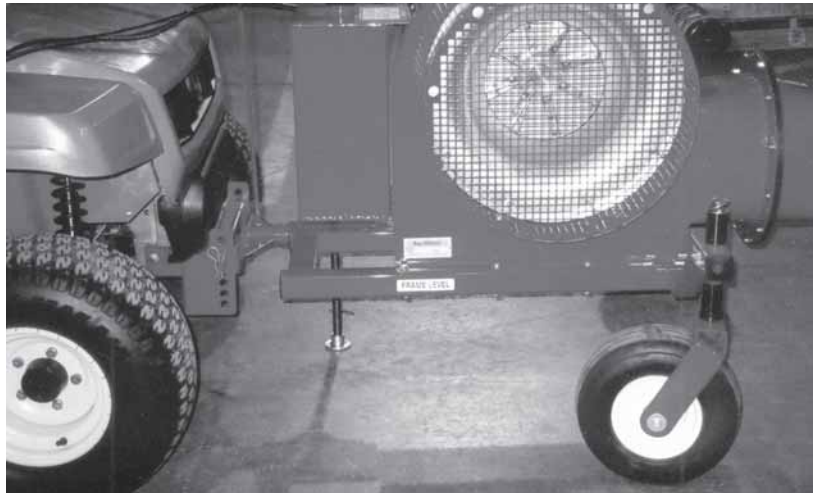

**Middle**

**Fig. 38 AXLE HEIGHT**



- b. Check and level the frame.

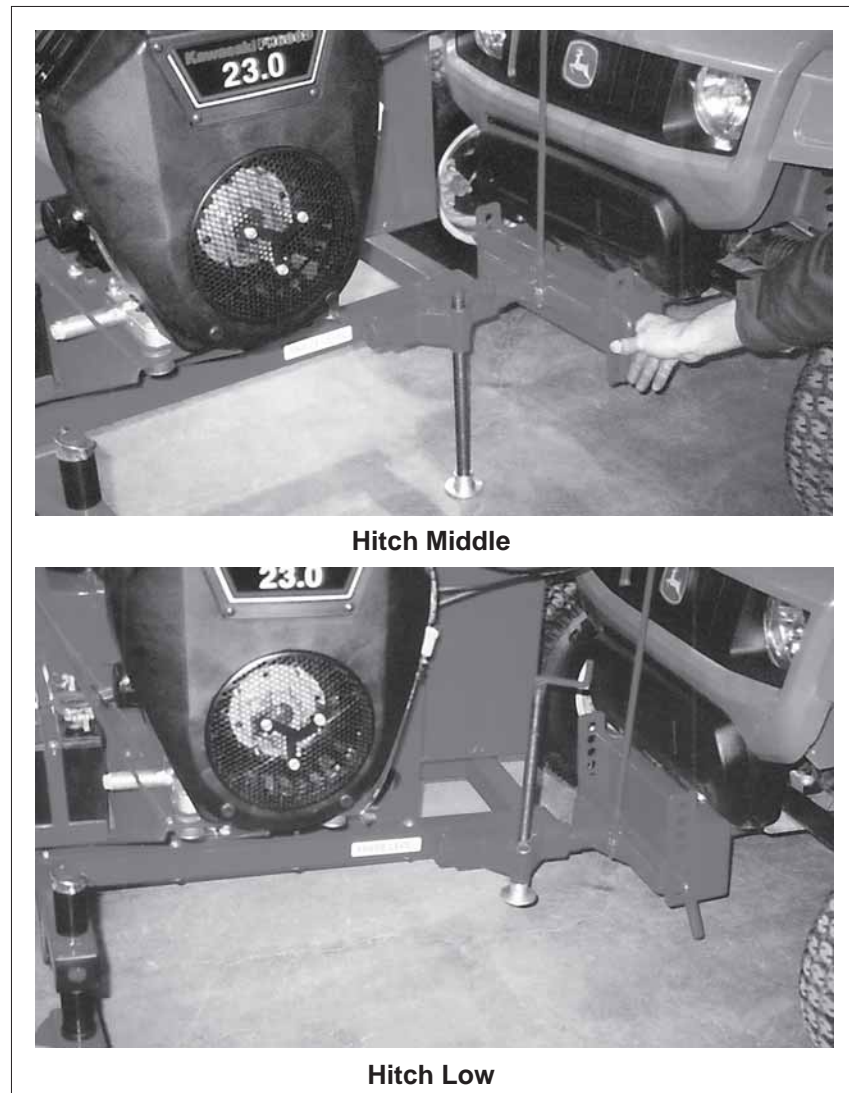

Fig. 39 HITCH POSITION

10. **Blower Engine Operating RPM:**  
Run the blower engine at a fast enough speed to get the job done.
11. Clean the intake screen as required to insure ample flow of air to the fan.
12. Always try to blow with the wind.  
Blowing against the wind can result in lifting the material into the wind and having it blown over a wider area.



Fig. 40 SCREEN

### 13. Application Hints:

- a. Cleaning fairways or large open areas:
  - i. When moving the material to one side, start at the opposite side and blow toward the receiving side. Use the center duct to change the air flow direction when coming back.
  - ii. When moving the material to all sides, start in the middle and move outward toward the edges while going around.
- b. Cleaning parking lots or other paved surfaces:
  - i. Blow only the area that needs cleaning.
  - ii. Run only at a speed necessary to move the debris.
  - iii. Direct the air stream with care. The blower can produce an air flow speed in excess of 292 kph (175 mph). At this speed, it can pick up small solid objects and move them over 30 m (100 feet). People, pets, animals, building, vehicle or other objects can be hit by these objects. Dust or sand can be blown in peoples eyes.
  - iv. It is best to stop for a short time to allow people to pass before running machine again.
- c. Drying wet areas:
  - i. Determine the area to be dried.
  - ii. Drive slowly past the area that is wet.
  - iii. Repeat the drive-by until the moisture is gone.



Fig. 41 WORKING

 **DANGER**



**THROWN OBJECT HAZARD**

**To prevent serious injury or death from a thrown object:**

1. Stop engine, place all controls in neutral, set park brake, remove ignition key and wait for all moving parts to stop before servicing, adjusting, repairing or unplugging machine.
2. Do not direct discharge duct toward people, animals or property. Always wear appropriate safety gear. Keep hands and feet out of discharge openings.
3. Keep others away.

**RISQUE D'OBJETS PROJETÉS**

**À défaut de suivre ces instructions, cela pourrait entraîner de sérieuses blessures ou même la mort.**

1. Arrêter le moteur, placer tous les contrôles à la position "neutre", enlever la clé du contact et attendre que toutes les places soient au point mort avant de faire tout ajustement, réparation ou de débloquer la machine.
2. Afin d'éviter tout risque d'accident grave, ne jamais souffler en direction des gens, des animaux ou vers les propriétés. Le port des équipements de sécurité est obligatoire lorsque vous opérez la machine.
3. Garder les gens éloignés de la machine.

## 5.8 TRANSPORTING



### TRANSPORT SAFETY

- Comply with state and local laws governing highway safety and movement of machinery on public roads.
- The use of flashing amber lights is acceptable in most localities. However, some localities prohibit their use. Local laws should be checked for all highway lighting and marking requirements.
- At all times when driving the utility vehicle and equipment on the road or highway under 20 mph (32 kph), use flashing amber warning lights and a slow moving vehicle (SMV) identification emblem. Do not exceed 20 mph (32 kph). Reduce speed on rough roads and surfaces.
- Plan your route to avoid heavy traffic.
- Use a mounting pin with provisions for a retainer. Install the retainer.
- Do not drink and drive.
- Be a safe and courteous driver. Always yield to oncoming traffic in all situations, including narrow bridges, intersections, etc. Watch for traffic when operating near or crossing roadways.
- Never allow riders on either push vehicle or machine.

When transporting the machine, review and follow these instructions:

1. Clear the area of bystanders, especially small children.
2. Be sure that the pushing unit has sufficient size and mass to control the Leaf Blower during transport.
3. Insure that the machine is securely attached to the push vehicle with a mechanical retainer through the mounting pin.
4. Do not allow riders on blower.
5. Never exceed a safe travel speed. Never travel faster than 32 kph (20 mph) The ratio of the push vehicle weight to the machine weight plays an important role in defining acceptable travel speed. The following table summarizes the weight ratio to travel speed.
6. Always shift to a lower gear when going down hill to use the engine as a restraining force.
7. Apply the brakes carefully to prevent losing control.
8. Never disengage utility vehicle drivetrain and coast down hills. Always keep utility vehicle in gear.

**Table 1 Travel Speed vs. Weight Ratio**

Road Speed	Weight of fully equipped or loaded implement(s) relative to weight of push vehicle
Up to 32 km/h (20 mph)	1 to 1, or less
Up to 16 km/h (10 mph)	2 to 1, or less
Do not push	More than 2 to 1

## 5.9 STORAGE



### STORAGE SAFETY

- Store the unit in an area away from human activity.
- Do not permit children to play on or around the stored machine.
- Store the unit in a dry, level area. Support the frame with planks if required.

At the end of the season, the machine should be thoroughly inspected and prepared for storage. Repair or replace any worn or damaged components to prevent any unnecessary down time at the beginning of the next season. Follow this procedure:

1. Thoroughly wash the machine with a pressure washer or water hose to remove all dirt, mud, debris or residue.
2. Make sure all the water drains out of the blower and duct compartments.
3. Lubricate all grease points to remove any water residue from washing.
4. Coat the roller chain coupler with a good quality chain lubricant to prevent rusting.
5. Remove any material that has become entangled around any moving part.
6. Run the machine for a couple of minutes at low RPM to dry the inside of the blower and duct.
7. Touch up all paint nicks and scratches to prevent rusting.

8. Move the machine to its storage area.
9. Store in a dry, level spot.
10. Store in an enclosed building if possible. If space is not available, cover with a waterproof tarpaulin and tie down securely.
11. Unhook from the push vehicle (see Section 5.6).
12. Place planks under the hitch and tires for added support if required.
13. Store in an area away from human activity.
14. Do not allow children to play around the stored unit.



Fig. 42 STORED

## 6 SERVICE AND MAINTENANCE



### MAINTENANCE SAFETY

- Good maintenance is your responsibility. Poor maintenance is an invitation to trouble.
- Follow good shop practices.
  - Keep service area clean and dry.
  - Be sure electrical outlets and tools are properly grounded.
  - Use adequate light for the job at hand.
- Make sure there is plenty of ventilation. Never operate an engine in a closed building. The exhaust fumes may cause asphyxiation.
- Before working on this machine, shut off the engine, set the brakes, and remove the ignition keys.
- Never work under equipment unless it is blocked securely.
- Always use personal protection devices such as eye, hand and hearing protectors, when performing any service or maintenance work.
- Where replacement parts are necessary for periodic maintenance and servicing, genuine factory replacement parts must be used to restore your equipment to original specifications. The manufacturer will not be responsible for injuries or damages caused by use of unapproved parts and/or accessories.
- A fire extinguisher and first aid kit should be kept readily accessible while performing maintenance on this equipment.
- Periodically tighten all bolts, nuts and screws and check that all cotter pins are properly installed to ensure unit is in a safe condition.
- When completing a maintenance or service function, make sure all safety shields and devices are installed before placing unit in service.

## 6.1 SERVICE

### 6.1.1 FLUIDS AND LUBRICANTS

1. **Grease:**  
Use an SAE multipurpose high temperature grease with extreme pressure (EP) performance. Also acceptable is an SAE multipurpose lithium base grease.
2. **Gasoline:**  
Use a super unleaded gasoline for all operating conditions. Do not use gasoline with an ethanol blend.

Capacity: 15 litres (4.0 gal).

3. **Engine Oil:**  
Use an SAE 30W viscosity oil meeting the American Petroleum Institute (API) classification of SF or SG for normal operating temperatures. Consult the engine manual for unusual operating conditions. Do not mix oil types or viscosities.

**Crankcase Capacity:**  
1.8 liters (2.0 US qt).

4. **Storing Lubricants:**  
Your machine can operate at top efficiency only if clean lubricants are used. Use clean containers to handle all lubricants. Store them in an area protected from dust, moisture and other contaminants.

### 6.1.2 GREASING

Use the Maintenance Checklist provided to keep a record of all scheduled maintenance.

1. Use a hand-held grease gun for all greasing.
2. Wipe grease fitting with a clean cloth before greasing, to avoid injecting dirt and grit.
3. Replace and repair broken fittings immediately.
4. If fittings will not take grease, remove and clean thoroughly. Also clean lubricant passageway. Replace fitting if necessary.



### 6.1.3 SERVICING INTERVALS

The period recommended is based on normal operating conditions. Severe or unusual conditions may require more frequent lubrication or oil changes.

#### 8 Hours or Daily

1. Clean blower air intake screen.



Fig. 43 AIR INTAKE SCREEN

2. Check engine oil level.



Fig. 44 DIPSTICK



3. Check fuel level.



**Fig. 45 GAS TANK**

### **50 Hours**

1. Change engine oil.

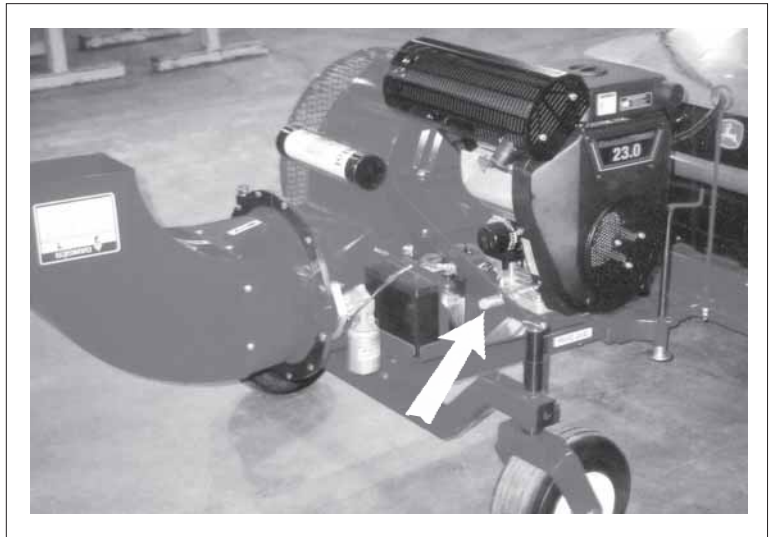

**Fig. 46 ENGINE DRAIN PLUG**

2. Clean air cleaner.
3. Check tire pressure. Pressurize to (25 psi) maximum.

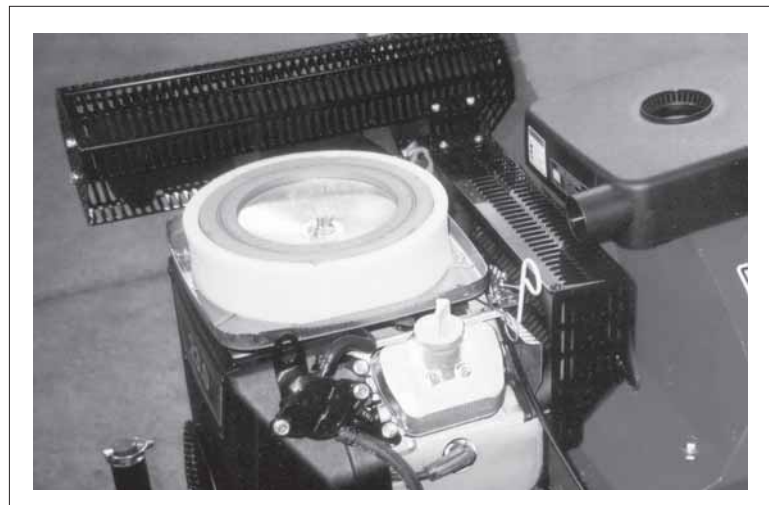

**Fig. 47 AIR CLEANER**

4. Grease castor shafts (2 locations).

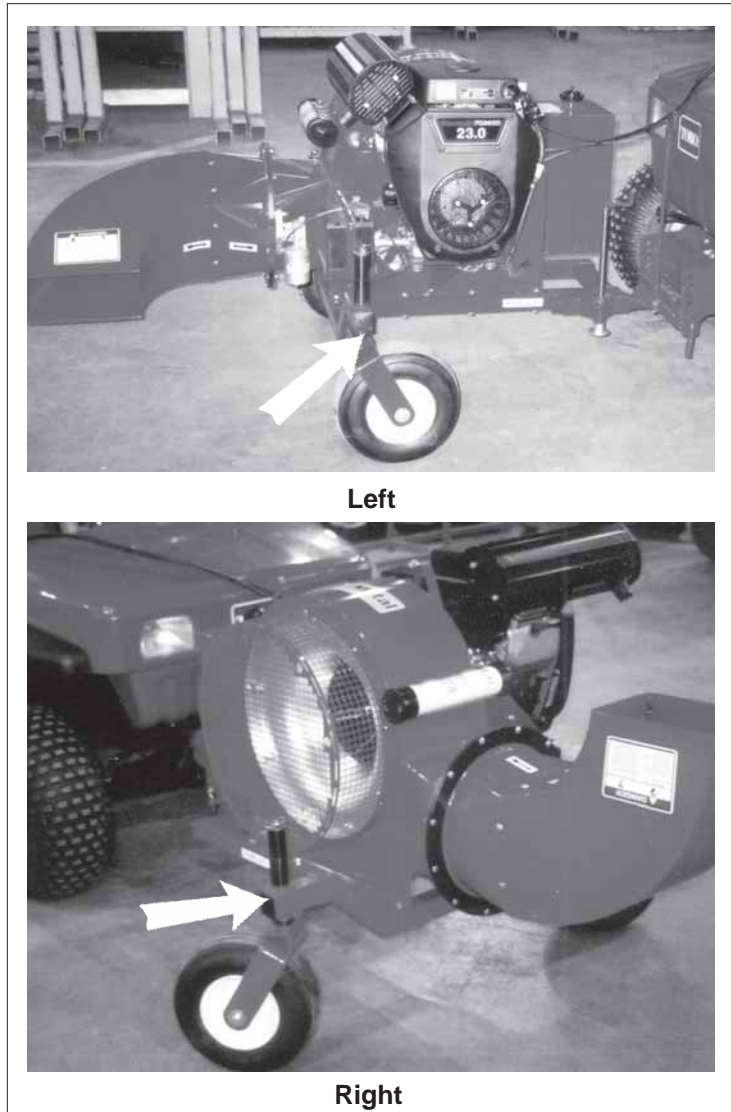

Fig. 48 CASTOR SHAFTS

#### 100 Hours

1. Change engine oil filter.



Fig. 49 OIL FILTER

**Annually**

1. Change in line fuel filter.

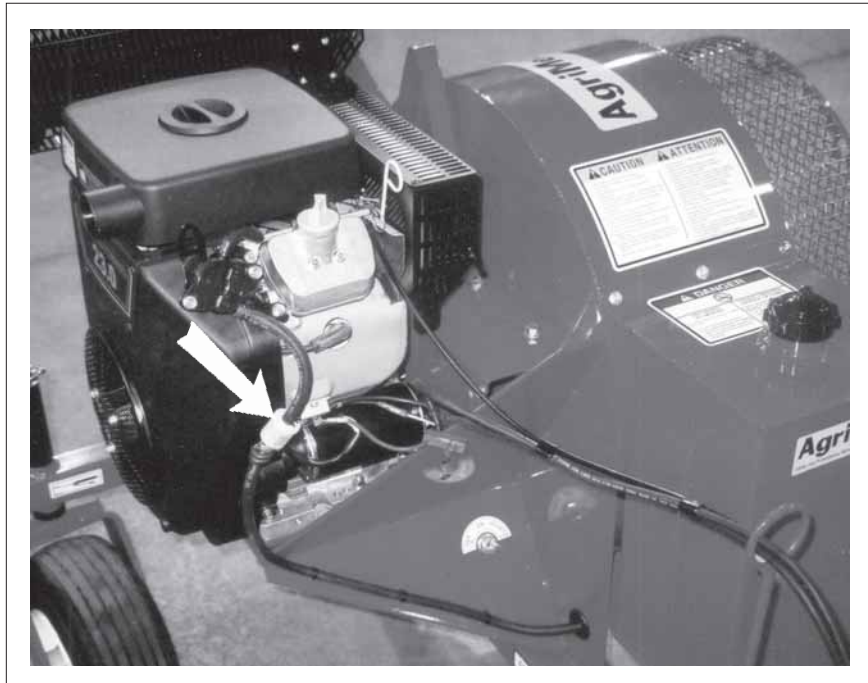

**Fig. 50 IN LINE FUEL FILTER**

2. Clean machine.



**Fig. 51 MACHINE**

## 6.1.4 SERVICE RECORD

See Lubrication and Maintenance sections for details of service. Copy this page to continue record.

ACTION CODE:      CK CHECK                      CL CLEAN  
                             G GREASE                      CH CHANGE

MAINTENANCE	HOURS																			
	SERVICED BY																			
<b>8 Hours or Daily</b>																				
CL Blower Air Intake Screen																				
CK Engine Oil Level																				
CK Fuel Level																				
<b>50 Hours</b>																				
CH Engine Oil																				
CL Air Cleaner																				
CK Tire Pressure																				
G Castor Shafts (2)																				
<b>100 Hours</b>																				
CH Engine Oil Filter																				
<b>Annually</b>																				
CH Inline Fuel Filter																				
CL Machine																				

## 6.2 MAINTENANCE

By following a careful service and maintenance program for your machine, you will enjoy many years of trouble-free operation.

### 6.2.1 CLEANING AIR CLEANER

1. Review the Operator's Manual for the engine.
2. Place all controls in neutral, stop engine and remove ignition key before maintaining.
3. Remove the cover over the air cleaner.
4. Remove the foam from the engine.
5. Use an air hose to blow the dust and debris out of the foam.
6. Install foam.
7. Install and secure the cover.

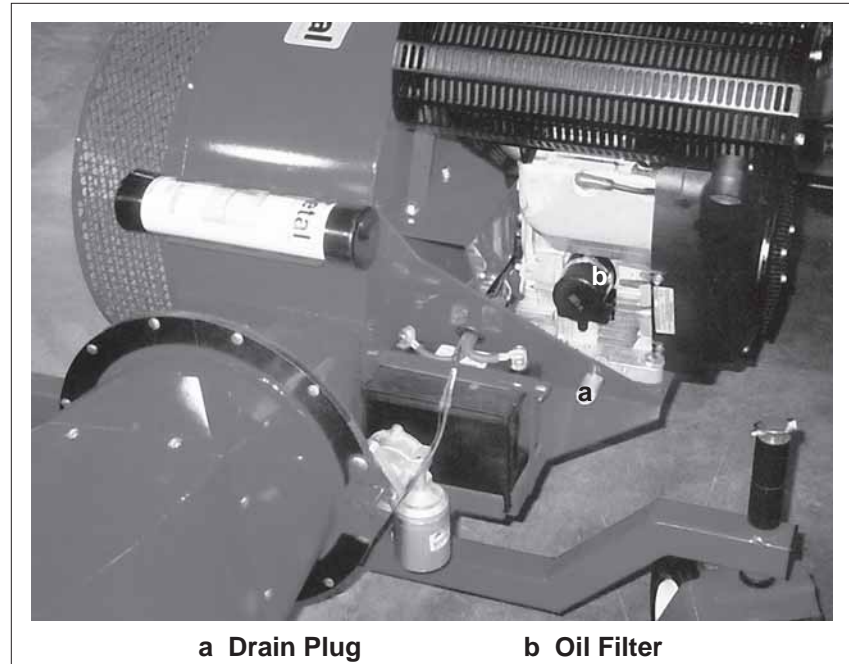

Fig. 52 AIR CLEANER



## 6.2.2 CHANGING ENGINE OIL AND FILTER

1. Review the Operator's Manual for the engine.
2. Place all controls in neutral, stop engine and remove ignition key before maintaining.
3. Allow the engine to cool before changing the oil. Hot oil can cause burns if it contacts exposed skin. It is best to change oil while the engine is warm to keep the contaminants in suspension.
4. Place a pan under the drain plug.
5. Remove the drain and allow the oil to drain for 10 minutes.
6. Install and tighten the drain plug.
7. Dispose of the used oil in an approved container.
8. Remove engine oil filter.
9. Apply a light coat of oil to the O ring and install the replacement filter. Snug up by hand and then tighten another 1/2 turn.
10. Fill the crankcase with specified oil.
11. Run the engine for 1-2 minutes and check for oil leaks.
12. If leaks are found around the drain plug or filter, tighten slightly. Repeat step 9.
13. Check engine oil level. Top up as required.



**Fig. 53 ENGINE (FRONT)**

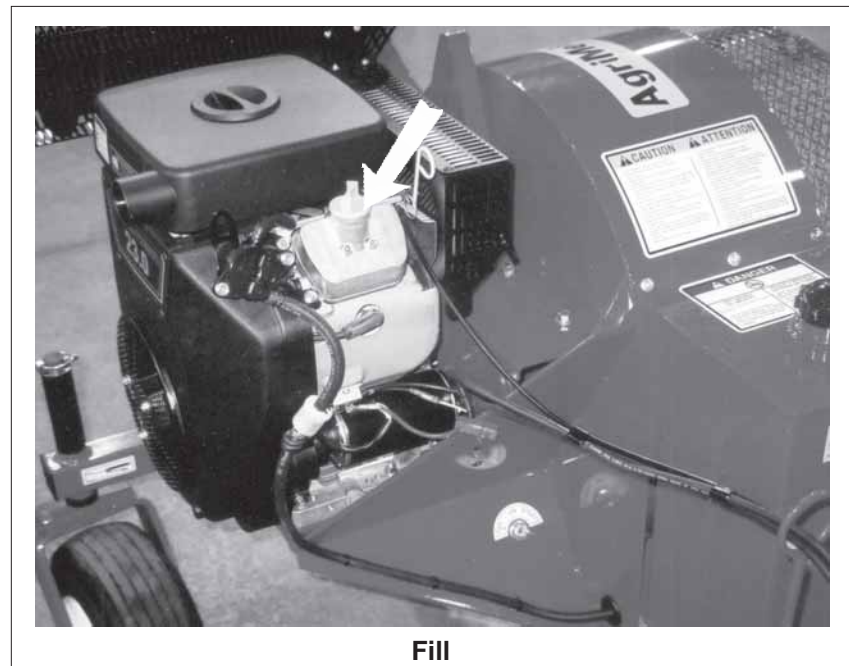

**Fig. 54 ENGINE (REAR)**



### 6.2.3 AXLE HEIGHT CONVERSION

The machine is shipped from the factory with the castor shafts on the wheels mounted in the up position to reduce the space required during shipping. It can be used in that configuration or converted to the middle or down positions. Different possible configuration to work on flat fairway or undulations terrain.

To convert the configuration, follow this procedure:

1. Clear the area of bystanders, especially small children.
2. Place all controls in neutral, stop engine, set park brake, remove ignition key and wait for all moving parts to stop before dismounting.
3. Use a floor jack to raise and support frame.

4. Remove the castor shaft retainer.
5. Remove shaft from frame and move one or both spacers over the

shaft as required.

6. Install shaft into frame.
7. Install retainer through shaft.

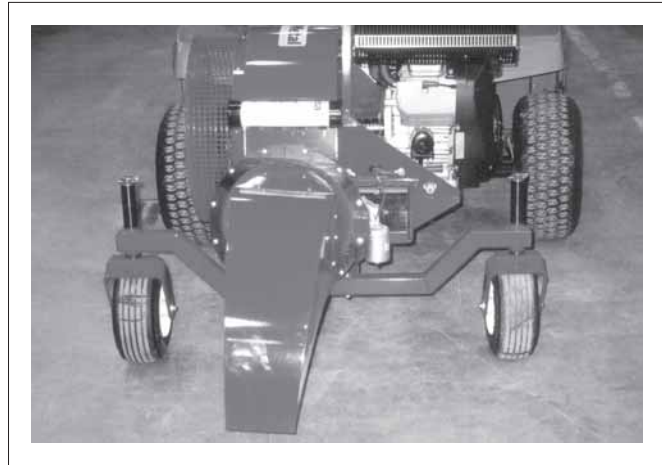

**Fig. 55 FACTORY SETTING**



**Retainer**



**Shaft**



**Mid Position**

**Fig. 56 RIGHT SHAFT**

8. Repeat with the left side:

- a. Use a floor jack to raise and support.



**Retainer**

- b. Remove castor shaft retainer.



**Shaft Removed**

- c. Remove shaft from frame and move one or both spacers over the shaft as required.

- d. Install shaft into frame.



**Shaft Installed**

- e. Install retainer through shaft.



**Installed**

**Fig. 57 LEFT WHEEL**

9. Check and level the frame if required.



Hitch Middle



Hitch Low

Fig. 58 LEVEL FRAME

## 7 TROUBLE SHOOTING

The AgriMetal Front mount Leaf Blower is a large portable blower that can be used to blow leaves, grass clippings, trash and debris. It is a simple system that requires minimal maintenance.

In the following Trouble Shooting section, we have listed many of the problems, causes and solutions that can help you to solve the problems that you might encounter.

If you encounter a problem that is difficult to solve, even after having read through this trouble shooting section, please call your local distributor or dealer. Before you call, please have this Operator's Manual and the serial number of your machine at hand.

<b>PROBLEM</b>	<b>CAUSE</b>	<b>SOLUTION</b>
Engine won't start	No fuel.	Check fuel level, add as required.
	Plugged in line filter.	Replace in line filter.
	No power from battery.	Loose cable. Tighten cable. Check fuse.  Battery low. Recharge battery.
Doesn't move debris/leaves.	No air flow.	Clean blower air intake screen.
	Wrong angle for air stream.	Level frame to provide proper air stream angle.  Change duct angle as required.
		Raise or lower wheel frame as required.

# 8 SPECIFICATIONS

## 8.1 MECHANICAL

<b>PULL TYPE BLOWER</b>	
<b>BWF 180</b>	
IMPELLER SIZE	457.2 mm x 88.9 mm (18" x 3 1/2")
NO. OF BLADES	8
AIR FLOW SPEED	292 kph (175 mph)
OUTLET SIZE	152.4 mm x 266.7 mm (6" x 10 1/2")
CHUTE ROTATION	360°
DRIVE	DIRECT
ENGINE	23 H.P.
'LENGTH	2743.2 mm (108")
WIDTH	1231.9 mm (48 1/2")
HEIGHT	1016 mm (40")
MACHINE WEIGHT	182 kg (400 lbs)
SHIPPING WEIGHT	200 kg (440 lbs)
SHIPPING DIMENSION	1270 mm x 1270 mm x 1168.4 mm (50" x 50" x 46")

**SPECIFICATIONS SUBJECT TO CHANGE WITHOUT NOTICE**

## 8.2 BOLT TORQUE

### CHECKING BOLT TORQUE

The tables shown below give correct torque values for various bolts and capscrews. Tighten all bolts to the torques specified in chart unless otherwise noted. Check tightness of bolts periodically, using bolt torque chart as a guide. Replace hardware with the same strength bolt.

### ENGLISH TORQUE SPECIFICATIONS

Bolt Diameter "A"	Bolt Torque *					
	SAE 2		SAE 5		SAE 8	
	N.m	(lb-ft)	N.m	(lb-ft)	N.m	(lb-ft)
1/4"	8	(6)	12	(9)	17	(12)
5/16"	13	(10)	25	(19)	36	(27)
3/8"	27	(20)	45	(33)	63	(45)
7/16"	41	(30)	72	(53)	100	(75)
1/2"	61	(45)	110	(80)	155	(115)
9/16"	95	(70)	155	(115)	220	(165)
5/8"	128	(95)	215	(160)	305	(220)
3/4"	225	(165)	390	(290)	540	(400)
7/8"	230	(170)	570	(420)	880	(650)
1"	345	(225)	850	(630)	1320	(970)

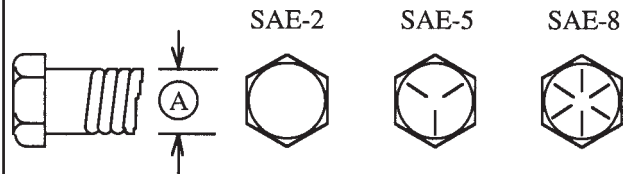

### METRIC TORQUE SPECIFICATIONS

Bolt Diameter "A"	Bolt Torque*			
	8.8		10.9	
	(N.m)	(lb-ft)	(N.m)	(lb-ft)
M3	.5	.4	1.8	1.3
M4	3	2.2	4.5	3.3
M5	6	4	9	7
M6	10	7	15	11
M8	25	18	35	26
M10	50	37	70	52
M12	90	66	125	92
M14	140	103	200	148
M16	225	166	310	229
M20	435	321	610	450
M24	750	553	1050	774
M30	1495	1103	2100	1550
M36	2600	1917	3675	2710

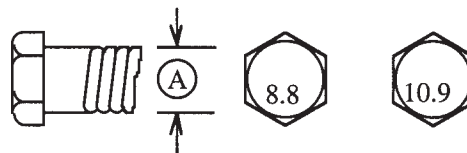

Torque figures indicated above are valid for non-greased or non-oiled threads and heads unless otherwise specified. Therefore, do not grease or oil bolts or capscrews unless otherwise specified in this manual. When using locking elements, increase torque values by 5%.

\* Torque value for bolts and capscrews are identified by their head markings.



# 10 INDEX

A	PAGE
Assembling .....	15
Machine Assembly .....	15
<b>I</b>	
Introduction .....	1
<b>O</b>	
Operation .....	21
Attaching/Unhooking .....	25
John Deere Gator and Turf TX .....	25
Kubota RTV 900 .....	36
Toro Twister .....	31
Break-In .....	23
Controls .....	24
Field Operation .....	45
Machine Components .....	22
Pre-Operation Checklist .....	23
Storage .....	52
To the New Operator or Owner .....	21
Transporting .....	51
<b>P</b>	
Parts List .....	67

S	PAGE
Safety .....	2
Battery Safety .....	9
Equipment Safety .....	4
Gas Motor Safety .....	10
General Safety .....	3
Maintenance Safety .....	9
Operating Safety .....	7
Preparation .....	6
Refuelling Safety .....	8
Safety Signs .....	5
Safety Training .....	5
Sign-Off Form .....	11
Storage Safety .....	8
Tire Safety .....	8
Transport Safety .....	8
Safety Sign Locations .....	12
Service and Maintenance .....	53
Maintenance .....	59
Axle Height Conversion .....	61
Changing Engine Oil and Filter .....	60
Cleaning Air Cleaner .....	59
Service .....	53
Fluids and Lubricants .....	53
Greasing .....	53
Service Record .....	58
Servicing Intervals .....	54
Specifications .....	65
Bolt Torque .....	66
Mechanical .....	65

T	
Trouble Shooting .....	64