

AgriMetal

PARTS LIST

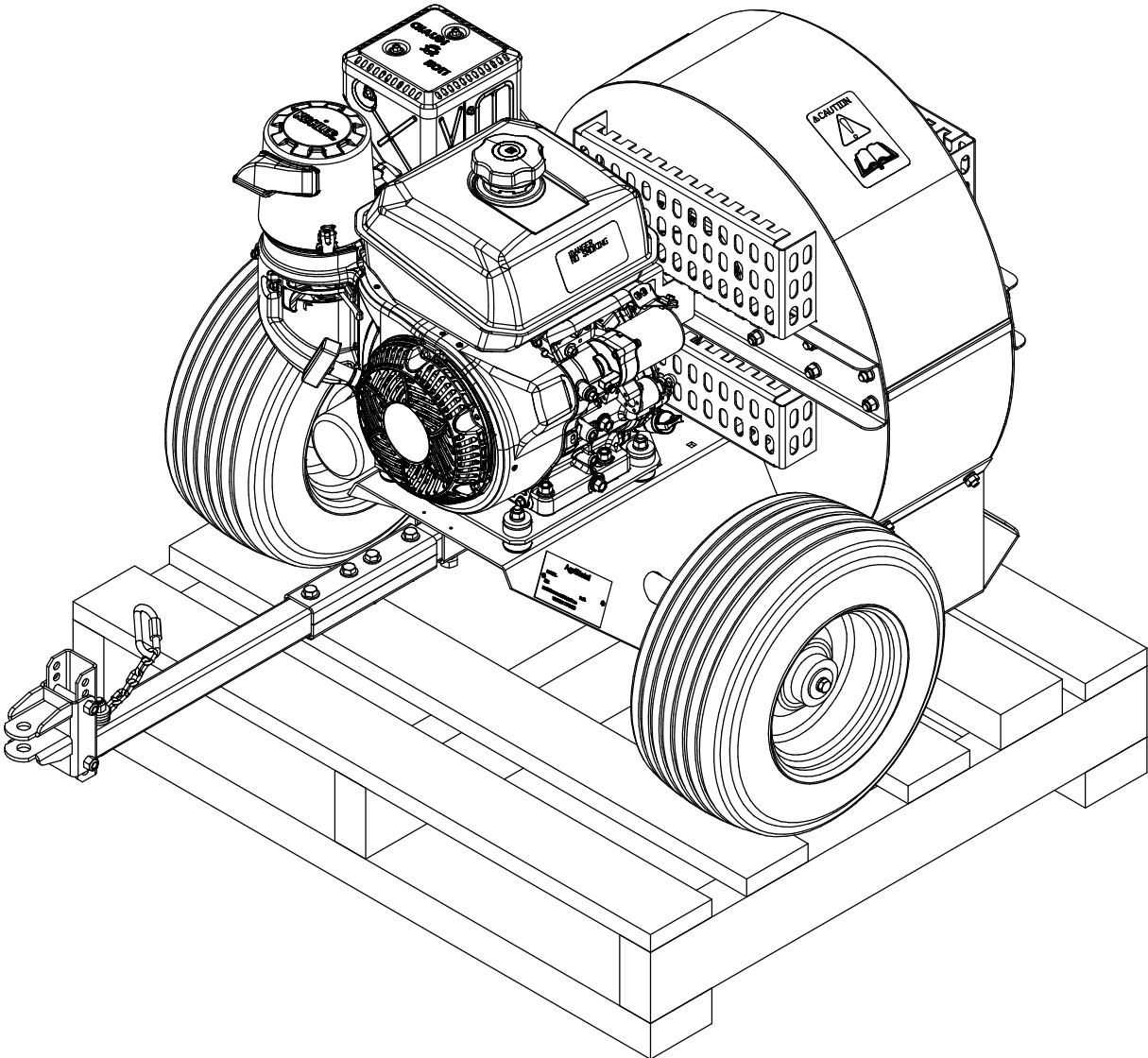

B.W.T. 150 (PULL START)

#	PART #	Qty	TITLE
1	22-50-0150	1	HYDRAULIC CONTROL SUPPORT
2	26-01-3115	2	CONTROL SUPPORT BRACKET
3	NC01-96-0009	8	NYLON-INSERT LOCKNUT ZINC 1/4-20
4	NC01-17-0004	4	HEX. BOLT GR2 ZINC 1/4-20 X 3/4"
5	NC01-17-0002	4	HEX. BOLT GR2 ZINC 1/4-20 X 1/2"
6	26-01-3080	1	CONTROL SUPPORT
7	26-01-3075	1	CONTROL SUPPORT (TOP)
8	NC01-64-0232	1	BLACK BALL 1 7/8" X 3/8-16
9	NC13-37-0572	1	41" SHEATH THROTTLE CONTROL
10	NC02-40-0080	6	MACHINE SCREWS SQUARE SOCKET #10-24 X 1/2" LG
11	NC01-96-0006	6	NYLON NUT ZINC 10-24

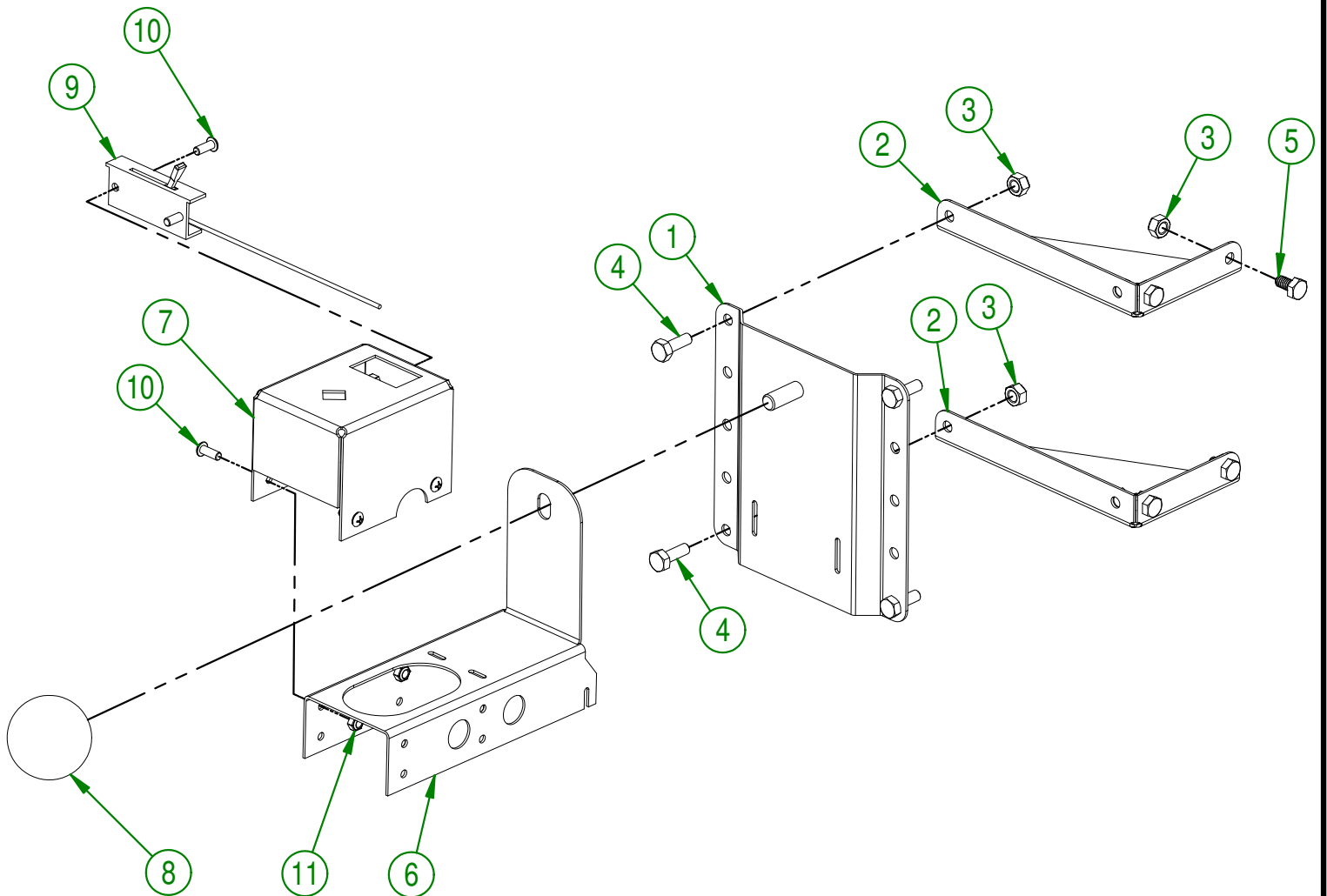

AGRIMETAL	
REMOTE THROTTLE (OPTION)	
CREATION : 30/05/18	ASSEMBLY : 26-55-1100
REVISION : 30/05/18	AUTHOR : F.HÉLIE
	Page 1 de 12

#	PART #	Qty	TITLE
1	26-07-0815	1	DRAWBAR EXTENSION
2	26-01-0920	2	DRAWBAR UNION
3	NC01-29-0121	4	HEX BOLT. GR5 NF ZINC 3/8-24 X 2 3/4"
4	01-01-2485	8	FLAT WASHER 14 GA X 13/16"OD X 25/64" ID
5	NC01-97-0006	4	HEX. LOCK NUT NF Z 3/8-24

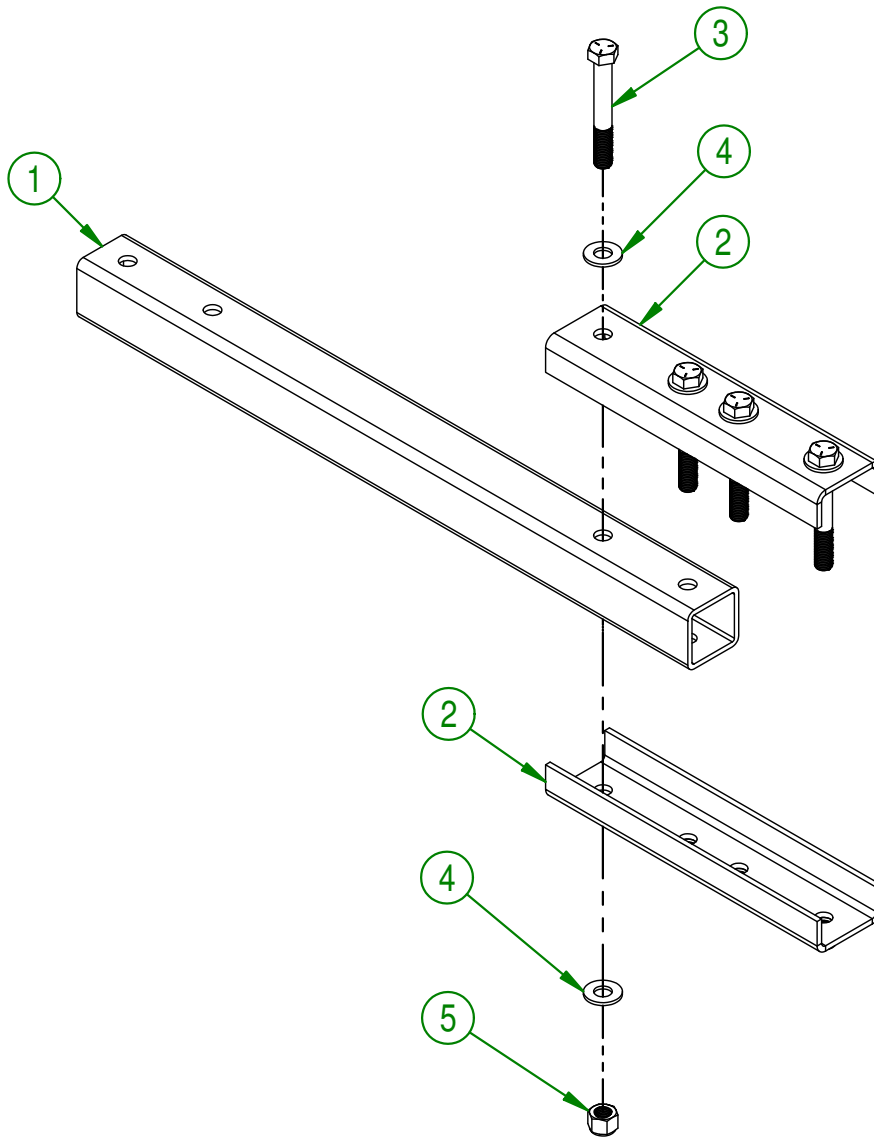

AGRIMETAL	
DRAWBAR EXTENSION 18" (OPTION)	
CREATION : 30/05/18	ASSEMBLY : 26-55-1105
REVISION : 30/05/18	AUTHOR : F.HÉLIE Page 2 de 12

#	PART #	Qty	TITLE
1	NC13-50-0086	1	SERIAL NUMBER PLATE
2	NC01-78-0055	2	ALUMINIUM BLIND POP RIVET STEEL MANDREL 0.125 X 0.515
3	26-01-7545	1	PROTECTOR SKATE
4	NC14-70-0078	2	WHEEL ASSEMBLY 16" X 6.50-8 BWT 150-180
5	01-33-0010	2	WASHER
6	NC01-17-0114	2	HEX. BOLT GR2 ZINC 3/8-16 X 1"
7	NC01-04-0055	6	CARR. BOLT GR2 ZINC 5/16-18 X 5/8"
8	NC02-32-0011	8	LOCK WASHER ZINC 5/16"
9	NC02-07-0017	8	HEX. NUT 5/16-18
10	NC02-22-0008	2	WASHER ZINC 5/16"
11	NC02-32-0012	2	LOCK WASHER ZINC 3/8"
12	26-55-1110	1	BLOWER COVER (LOW SECTION) (MOD.B.W.T.150)
13	26-07-0800	1	DRAWBAR
14	NC01-17-0246	2	HEX. BOLT GR2 NC ZINC 1/2-13 X 3/4
15	26-55-0090	1	ADJUSTABLE DRAW BAR HITCH

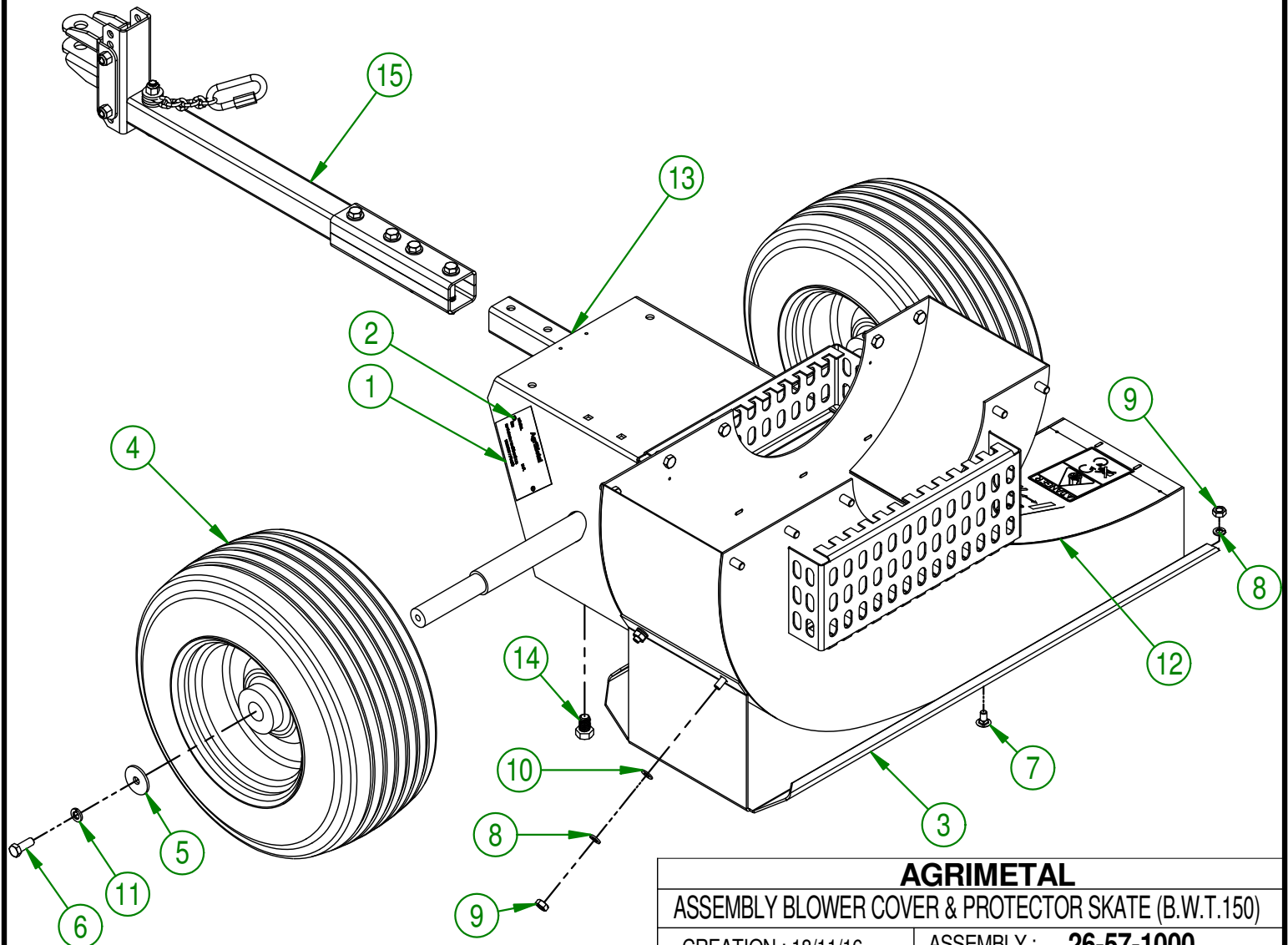

AGRIMETAL	
ASSEMBLY BLOWER COVER & PROTECTOR SKATE (B.W.T.150)	
CREATION : 18/11/16	ASSEMBLY : 26-57-1000
REVISION : 30/05/18	AUTHOR : F.HÉLIE
	Page 3 de 12

#	PART #	Qty	TITLE
1	26-50-0010	1	ADJUSTABLE DRAW BAR
2	26-50-0015	1	HITCH
3	26-01-0920	2	DRAWBAR UNION
4	NC01-29-0121	3	HEX BOLT. GR5 NF ZINC 3/8-24 X 2 3/4"
5	NC02-32-0012	4	LOCK WASHER ZINC 3/8"
6	NC02-07-0018	4	HEX. NUT ZINC 3/8-16
7	NC01-17-0120	4	HEX.BOLT GR2 NC ZINC 3/8-16 X 2 1/2
8	21-01-0950	4	FLAT WASHER IOGA 1.005" DIA X 25/64"
9	NC01-97-0006	3	HEX. LOCK NUT NF Z 3/8-24
10	01-01-2485	8	FLAT WASHER
11	26-41-0000	1	SAFETY CHAIN 4.8MM X 2/0 X 58" LONG
12	NC01-75-0015	1	RAPID LINK DIA. 5/16"-8MM, 1300-1760 LBS WLL

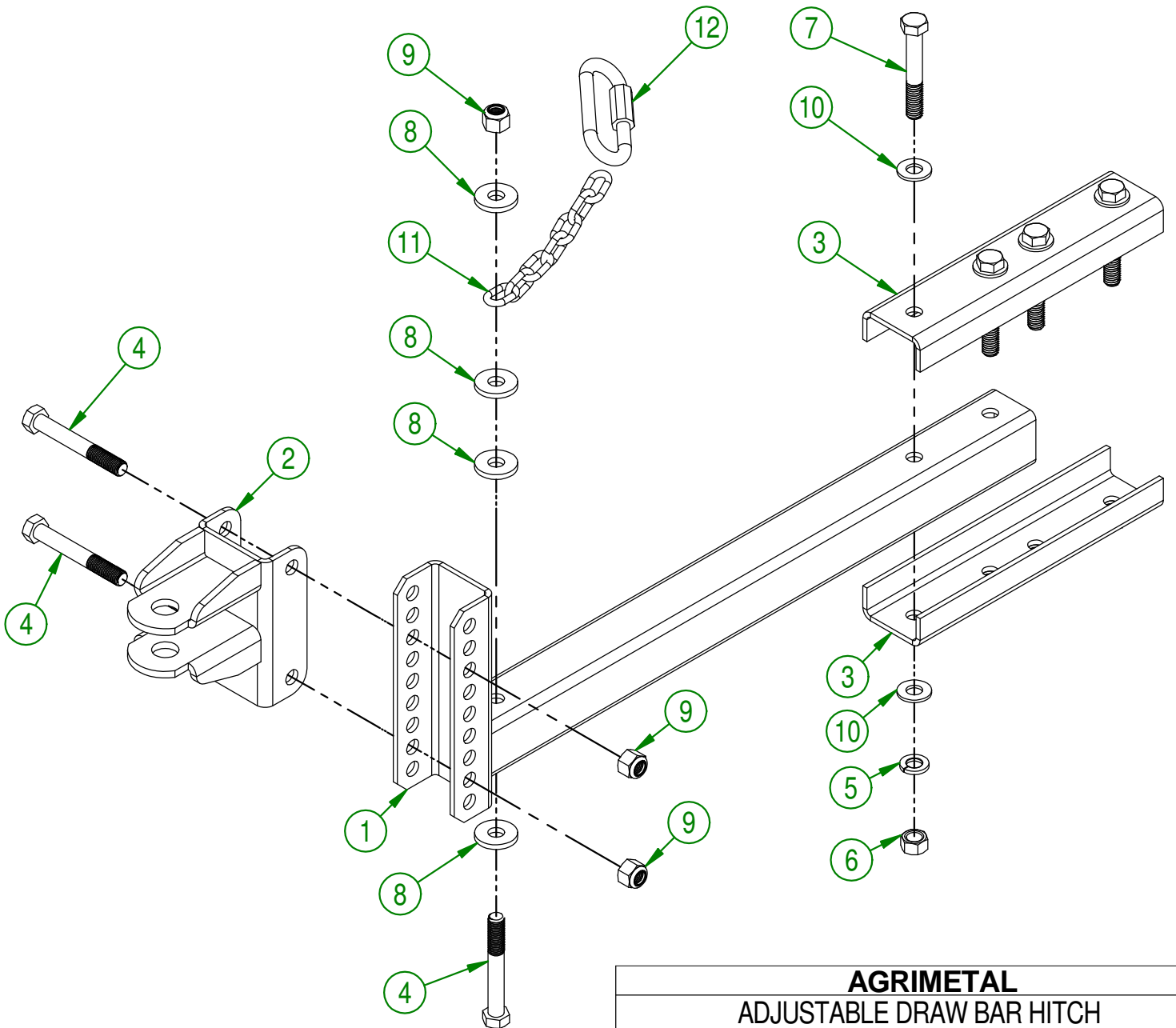

AGRIMETAL		
ADJUSTABLE DRAW BAR HITCH		
CREATION : 18/11/16	ASSEMBLY : 26-55-0090	
REVISION : 30/05/18	AUTHOR : Dessin2	Page 4 de 12

#	PART #	Qty	TITLE
1	26-55-1115	1	BLOWER COVER (HIGH SECTION) (MOD.B.W.T.150)
2	26-01-7525	1	BLOWER CHANNEL (FRONT)
3	26-01-7520	1	BLOWER CHANNEL (REAR)
4	NC02-32-0012	20	LOCK WASHER ZINC 3/8"
5	NC02-07-0018	20	HEX. NUT ZINC 3/8-16

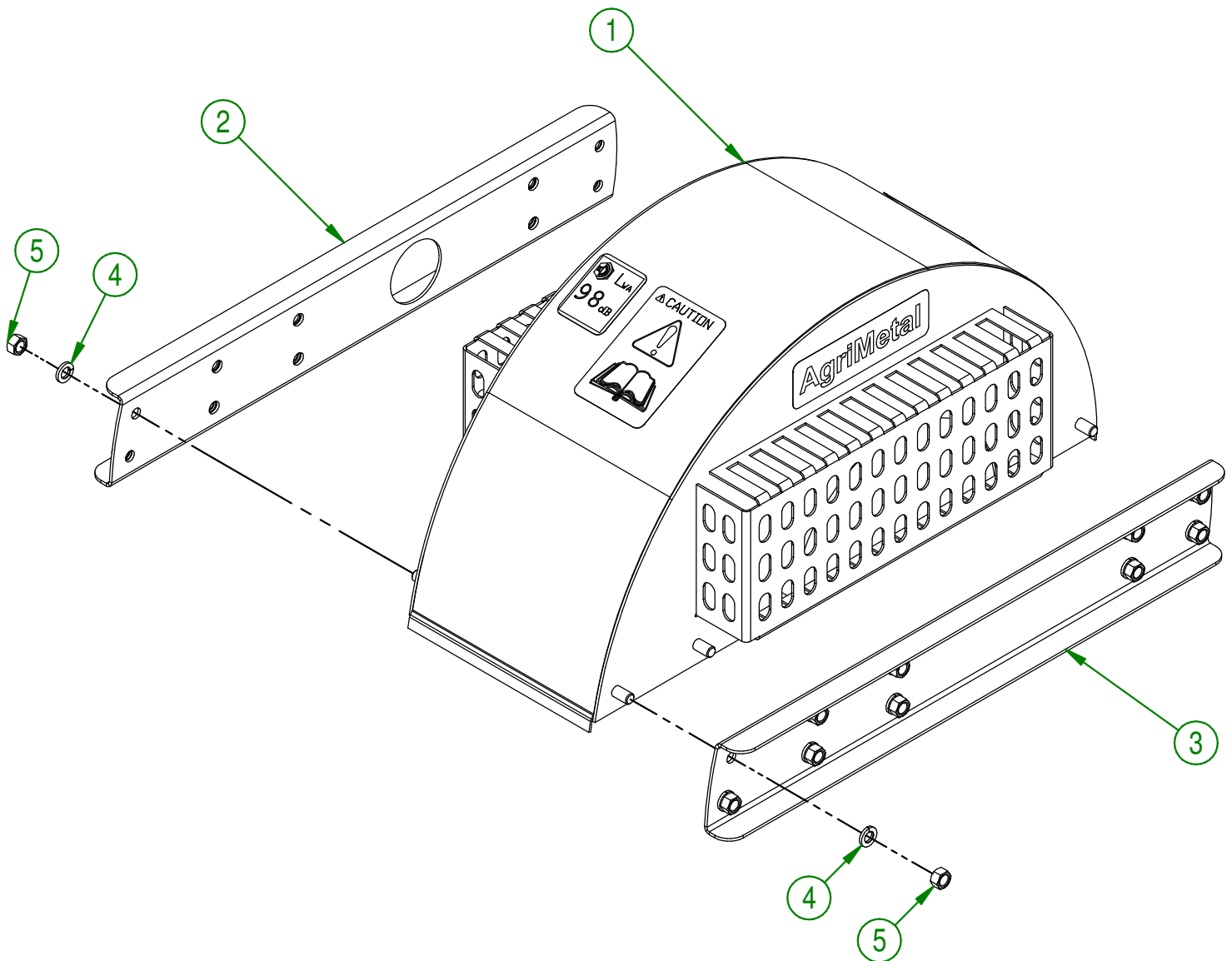

AGRIMETAL	
ASSEMBLY BLOWER COVER	
CREATION : 18/11/16	ASSEMBLY : 26-57-1020
REVISION : 07/09/21	AUTHOR : F.HÉLIE

#	PART #	Qty	TITLE
1	26-55-1081	1	IMPELLER
2	NC01-65-0087	1	KEY 1/4 X 1/4 X 1 1/2"
3	NC01-98-0020	1	NYLON NUT HEX. 1 1/8 UNF-3B THIN
4	NC02-32-0012	1	LOCK WASHER ZINC 3/8"
5	26-09-0600	1	IMPELLER COUPLING CONE SHAFT
6	26-21-0090	1	EXTRACTOR BOLT STOP
7	26-20-0075	1	IMPELLER SHAFT
8	21-01-0950	1	FLAT WASHER IOGA 1.005" DIA X 25/64"
9	26-31-0105	1	IMPELLER BOLT

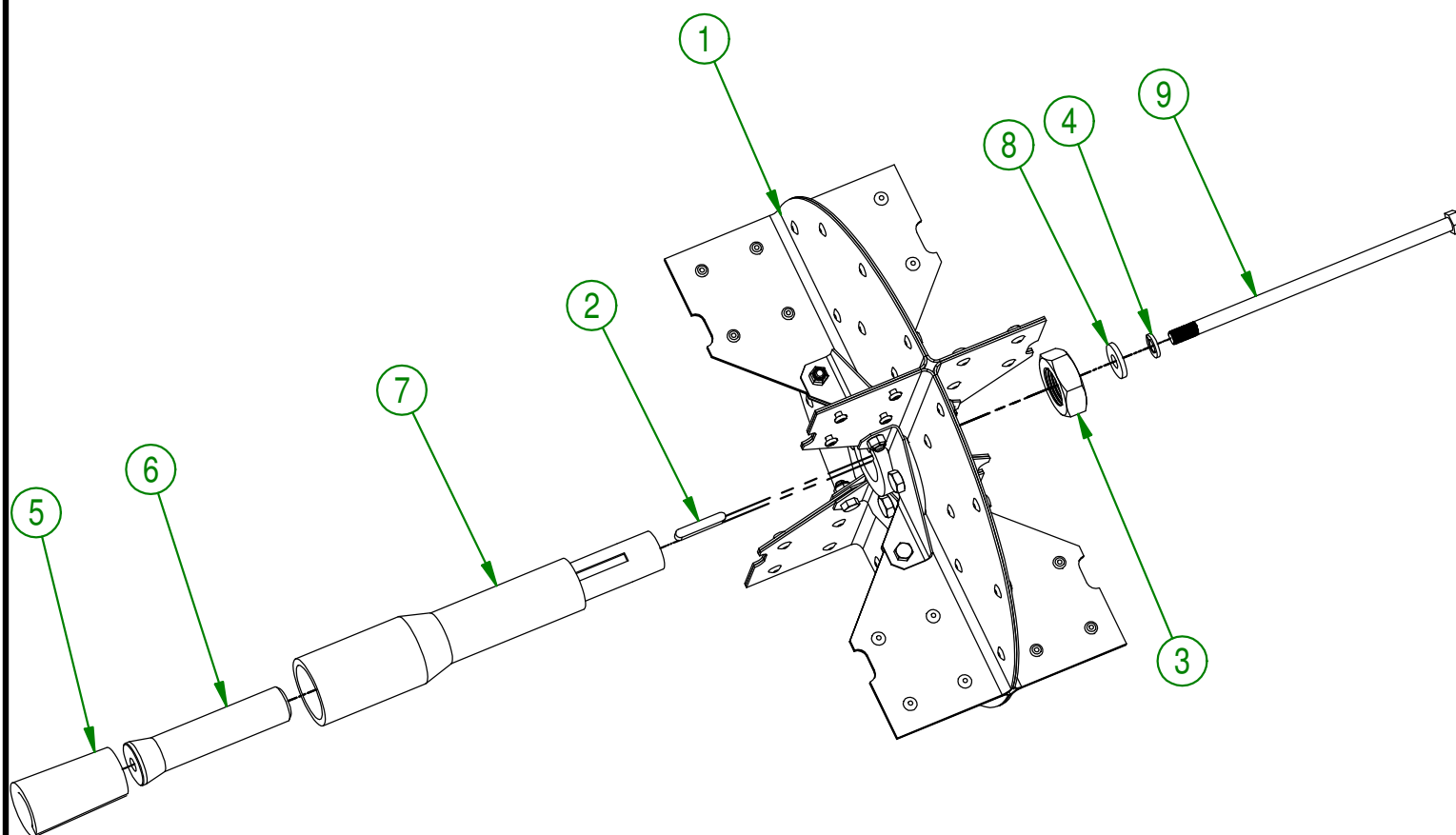

AGRIMETAL	
ASSEMBLY IMPELLER KIT	
CREATION : 18/11/16	ASSEMBLY : 26-57-1016
REVISION : 19/06/18	AUTHOR : F.HÉLIE Page 6 de 12

#	PART #	Qty	TITLE
1	NC13-15-0059	4	YELLOW RUBBER BASE MOUNT
2	26-22-0400	4	MOTOR BASE WASHER
3	26-03-4800	8	WASHER
4	26-03-4205	4	MOTOR BASE WASHER
5	NC01-17-0119	4	HEX. BOLT GR2 ZINC 3/8-16 X 2 1/4"
6	NC02-32-0012	4	LOCK WASHER ZINC 3/8"
7	NC02-07-0018	4	HEX. NUT ZINC 3/8-16

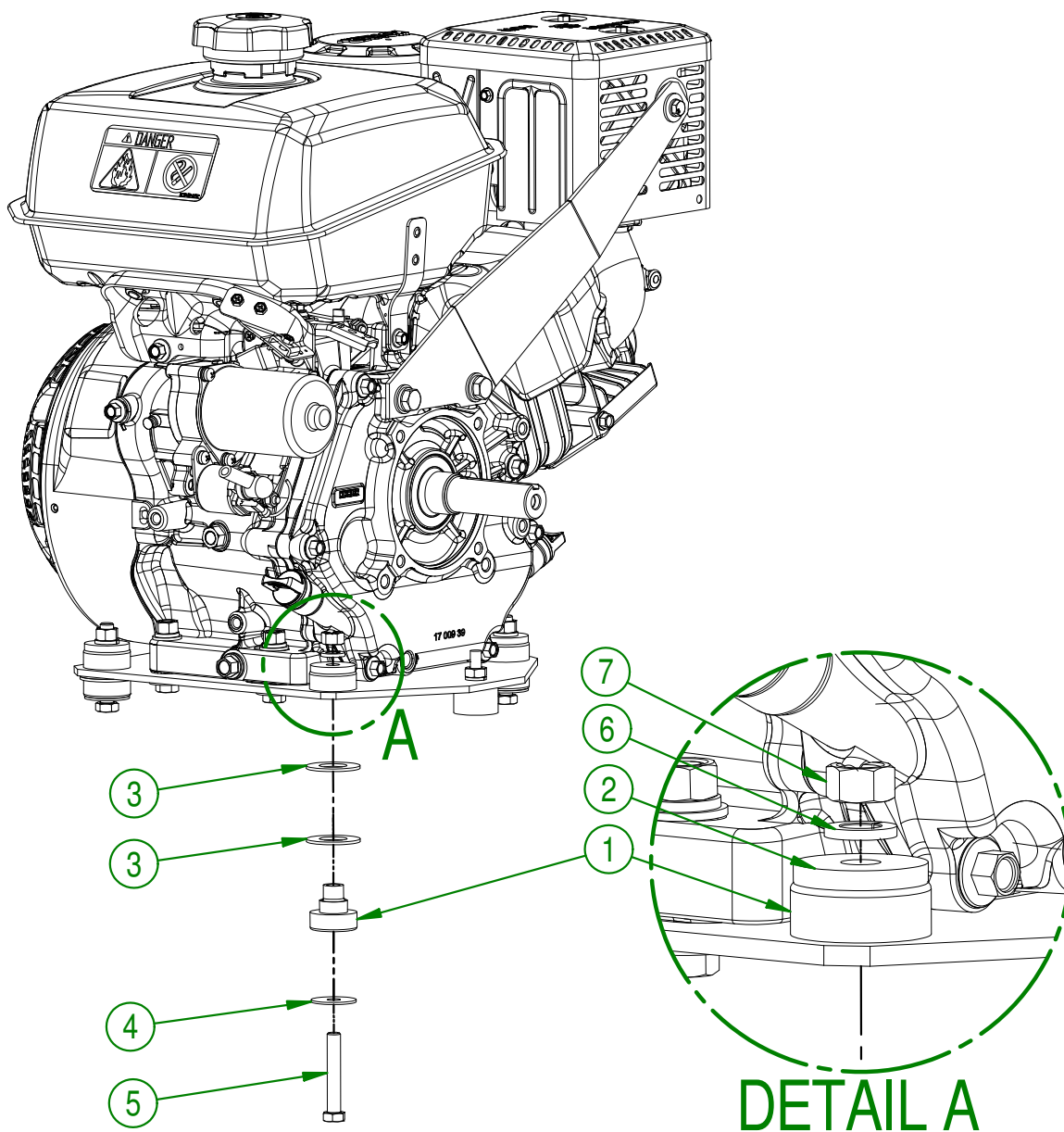

AGRIMETAL	
ASSEMBLY KOHLER MOTOR	
CREATION : 01/06/18	ASSEMBLY : 26-57-1010
REVISION : 03/01/19	AUTHOR : F.HÉLIE Page 7 de 12

#	PART #	Qty	TITLE
1	NC13-15-0034	1	RUBBER ABSORBER
2	NC02-32-0011	1	LOCK WASHER ZINC 5/16"
3	NC02-07-0017	1	HEX. NUT 5/16-18
4	26-04-0055	1	MOTOR BASE
5	NC01-17-0117	4	HEX. BOLT GR2 ZINC 3/8-16 X 1 3/4"
6	21-01-0950	4	FLAT WASHER 10GA 1.005" DIA X 25/64"
7	01-01-2485	4	FLAT WASHER 14 GA X 13/16"OD X 25/64" ID
8	NC02-32-0012	4	LOCK WASHER ZINC 3/8"
9	NC02-07-0018	4	HEX. NUT ZINC 3/8-16

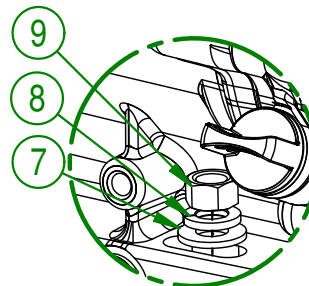
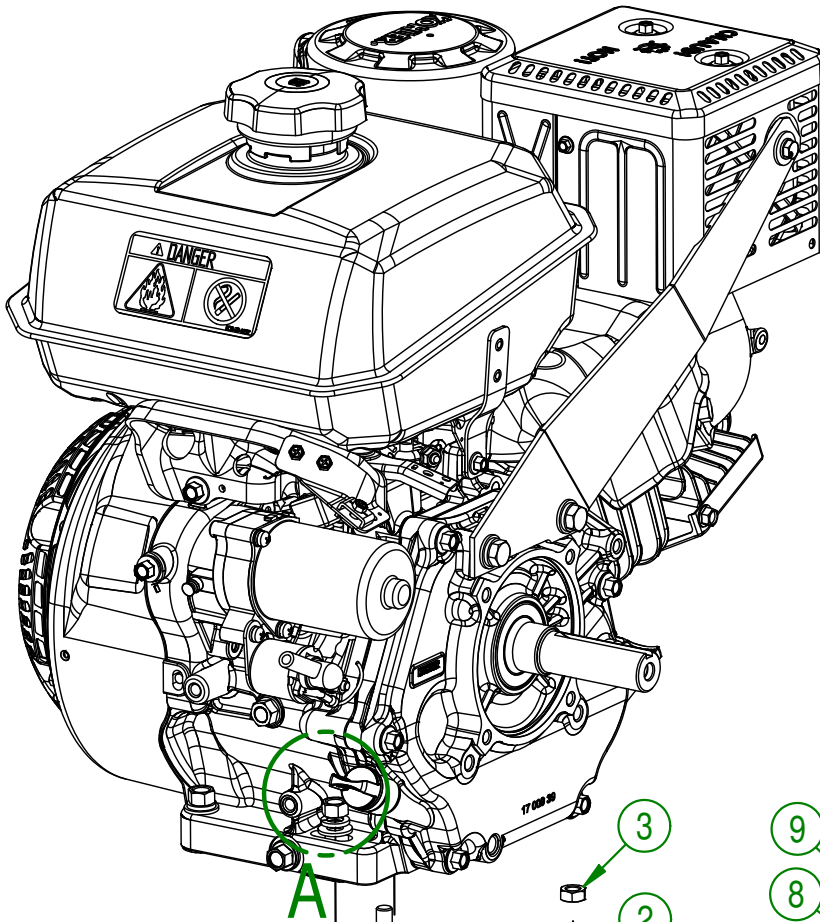

DETAIL A

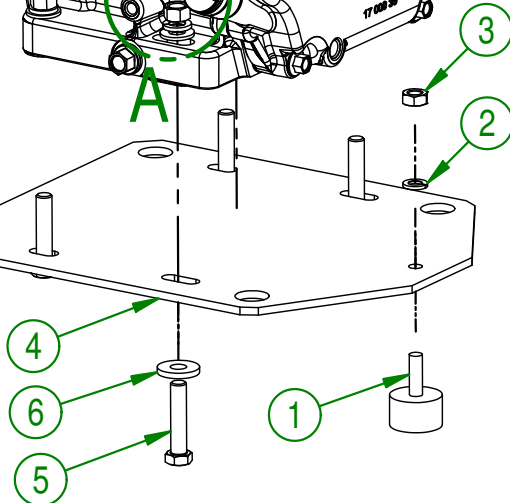

AGRIMETAL	
KOHLER MOTOR (MANUAL) ASSEMBLY (B.W.T.150)	
CREATION : 19/06/18	ASSEMBLY : 26-55-1001
REVISION : 30/08/19	AUTHOR : F.HÉLIE Page 8 de 12

#	PART #	Qty	TITLE
1	26-01-1180	1	MUFFLER HOLDER
2	NC01-17-0114	2	HEX. BOLT GR2 ZINC 3/8-16 X 1"
3	NC02-32-0012	2	LOCK WASHER ZINC 3/8"
4	01-01-2485	2	FLAT WASHER 14 GA X Ø13/16" X Ø25/64"
5	26-21-0098	1	MUFFLER HOLDER RING
6	NC-01-45-0116	1	METRIC BOLT GR8.8 NC ZINC 6MM X 25 MM
7	NC02-32-0010	1	LOCK WASHER ZINC 1/4"
8	36-01-2430	1	WASHER

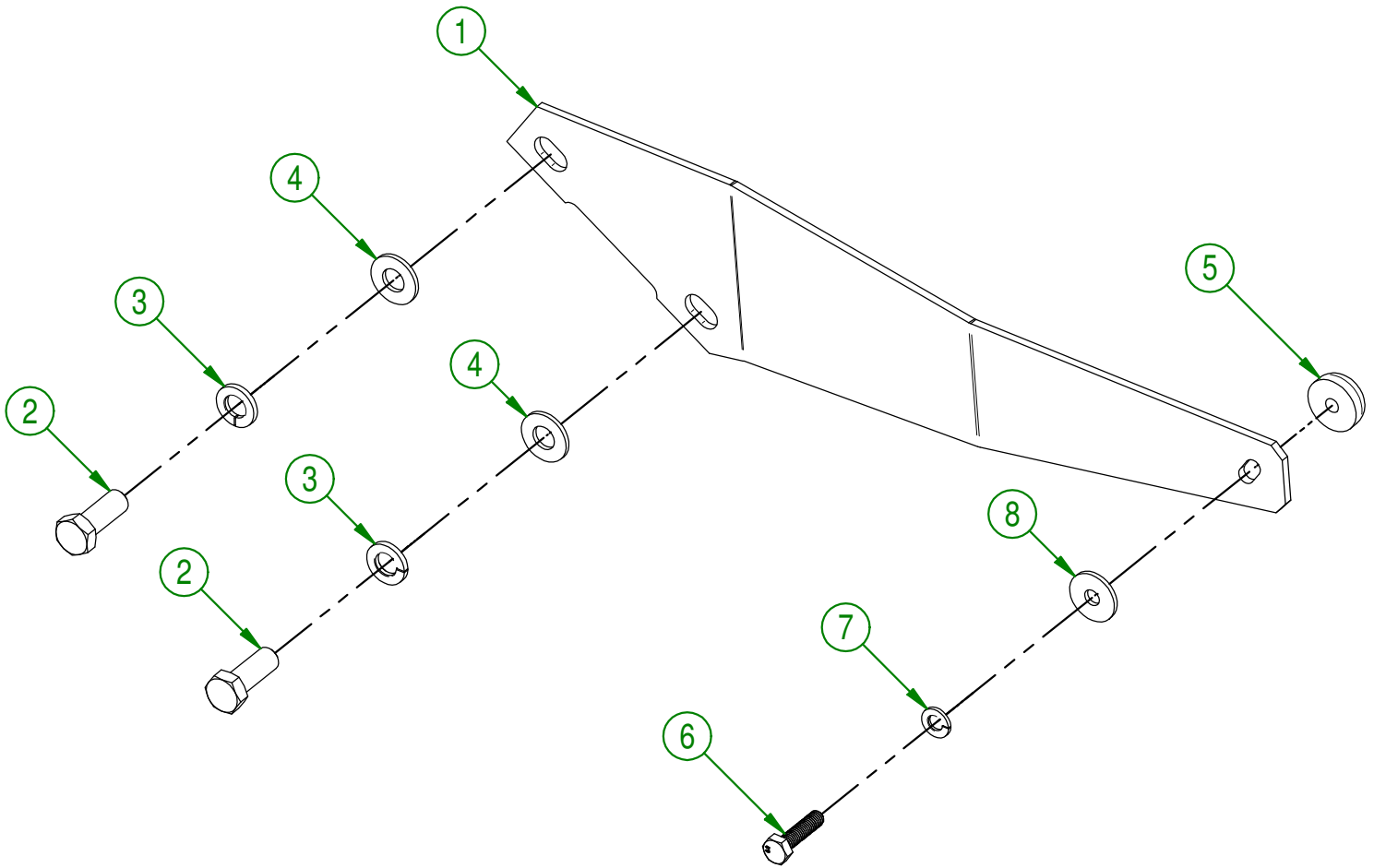

AGRIMETAL	
MUFFLER BRACKET ASSEMBLY	
CREATION : 18/11/16	ASSEMBLY : 26-57-1030
REVISION : 19/06/18	AUTHOR : Dessin2 Page 9 de 12

#	PART #	Qty	TITLE
1	26-55-0110	1	IMPELLER COUPLER GUARD (B.W.T.140&150)
2	NC01-21-0058	2	HEX. BOLT GR2 NF ZINS 5/16-24 X 3/4
3	NC02-32-0011	2	LOCK WASHER ZINC 5/16"

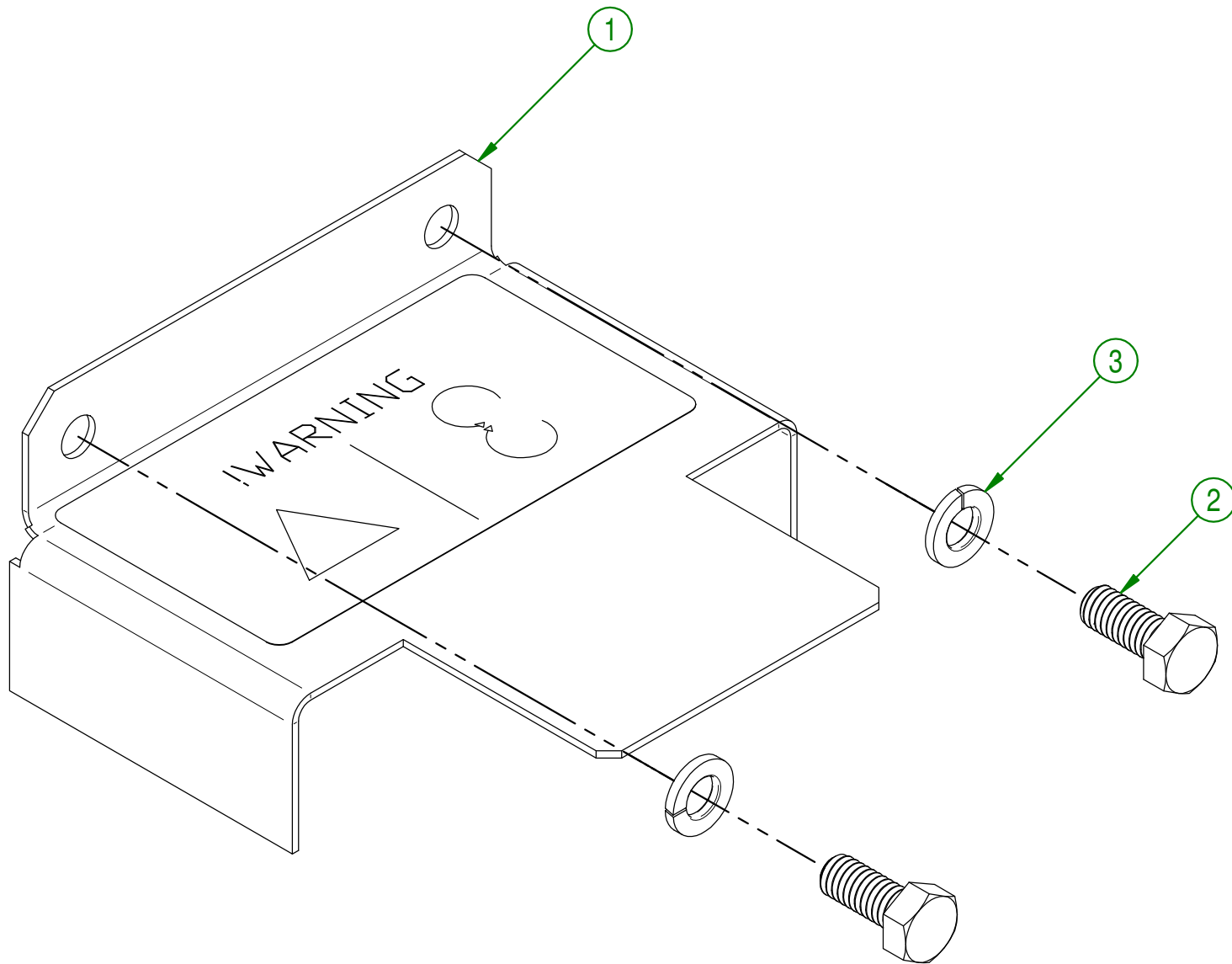

AGRIMETAL	
ASSEMBLY IMPELLER COUPLER GUARD (B.W.T.140&150)	
CREATION : 18/11/16	ASSEMBLY : 26-57-0025
REVISION : 30/05/18	AUTHOR : F.HÉLIE Page 10 de 12

#	PART #	Qty	TITLE
1	NC13-30-0237	1	PLASTIC TUBE FOR OPERATOR'S MANUAL
2	26-50-1030	1	EXTRACTOR BOLT
3	NC13-50-0054	1	INSTRUCTION MANUAL B.W.T-150 (CE) (ENGLISH)
4	NC01-04-0003	3	CARR. BOLT GR2 ZINC 1/4-20 X 3/4"
5	NC02-25-0007	3	WASHER ZINC 0.281 = 9/32
6	NC01-96-0009	3	NYLON-INSERT LOCKNUT ZINC 1/4-20

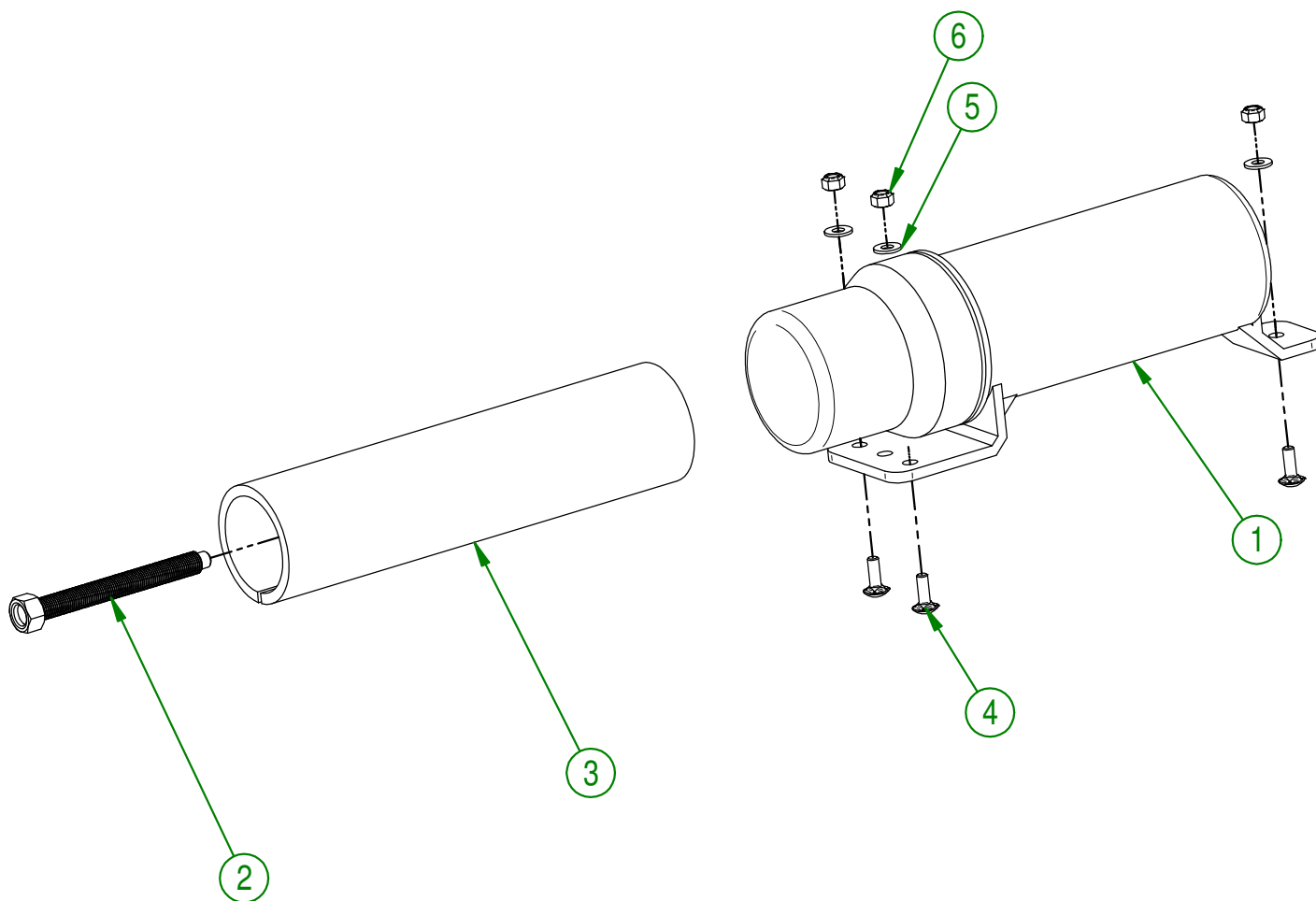

AGRIMETAL	
ASSEMBLY INSTRUCTION MANUAL TUBE	
CREATION : 18/11/16	ASSEMBLY : 26-57-1035
REVISION : 30/05/18	AUTHOR : F.HÉLIE Page 11 de 12

#	PART #	QTY	TITLE
1	NCI3-33-0192	1	STICKER (PROJECTION RISK)
2	NCI3-33-0186	1	STICKER (DANGER)
3	NCI3-33-0151	1	STICKER (IMPORTANT TO PREVENT ENGINE FAILURE...)
4	NCI3-33-0002	1	STICKER AGRIMETAL
5	NCI3-33-0183	1	STICKER CAUTION OPERATION MANUAL
6	NCI3-33-0341	1	STICKER 98 DB
7	NCI3-33-0252	1	STICKER (FIRE RISK)
8	NCI3-33-0276	2	STICKER (WARNING)

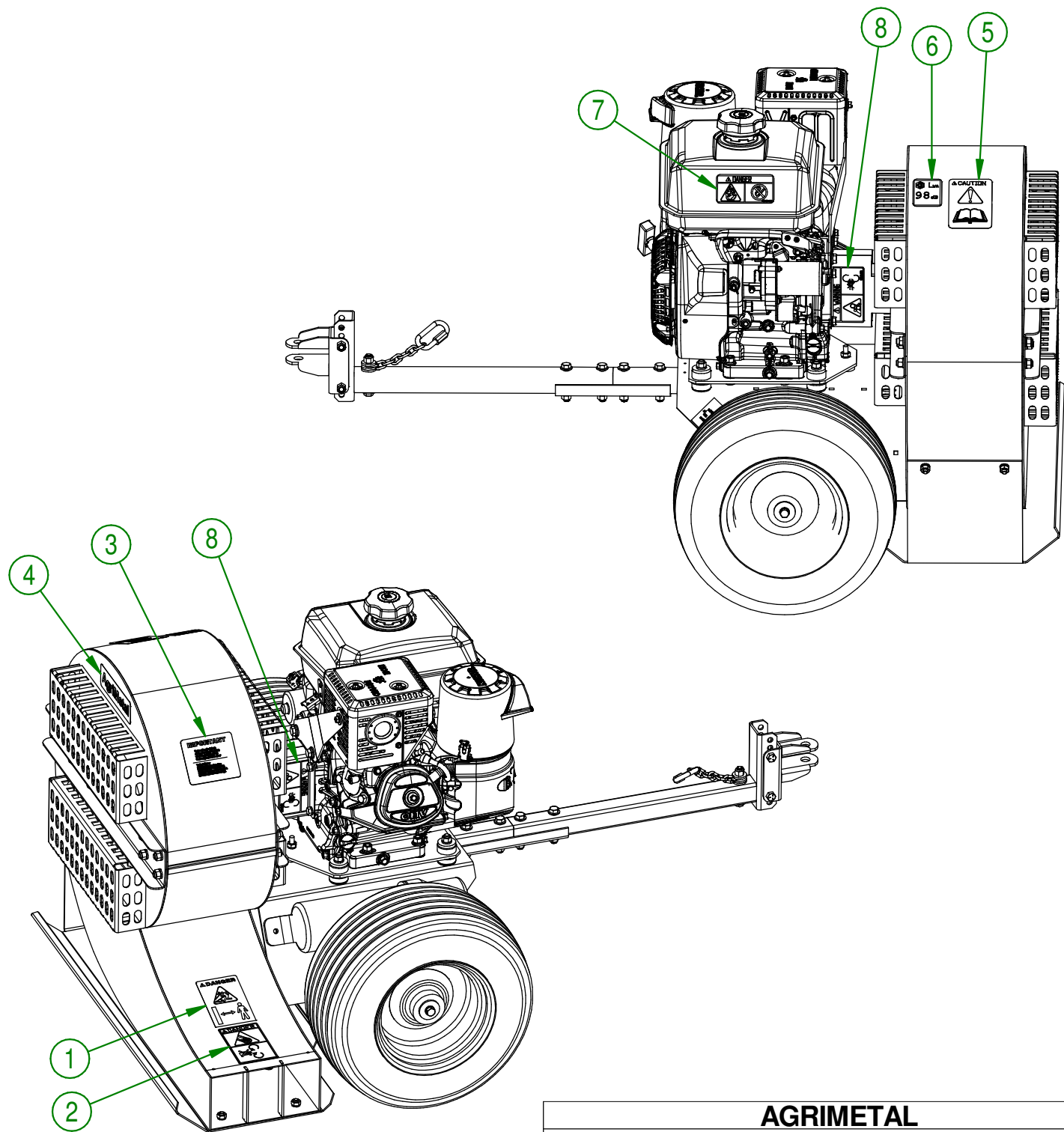

AGRIMETAL	
B.W.T.150 (PULL START)	
CREATION : 01/06/18	ASSEMBLY : 26-99-0500
REVISION : 14/09/21	AUTHOR : F.HÉLIE