

AgriMetal

PARTS LIST

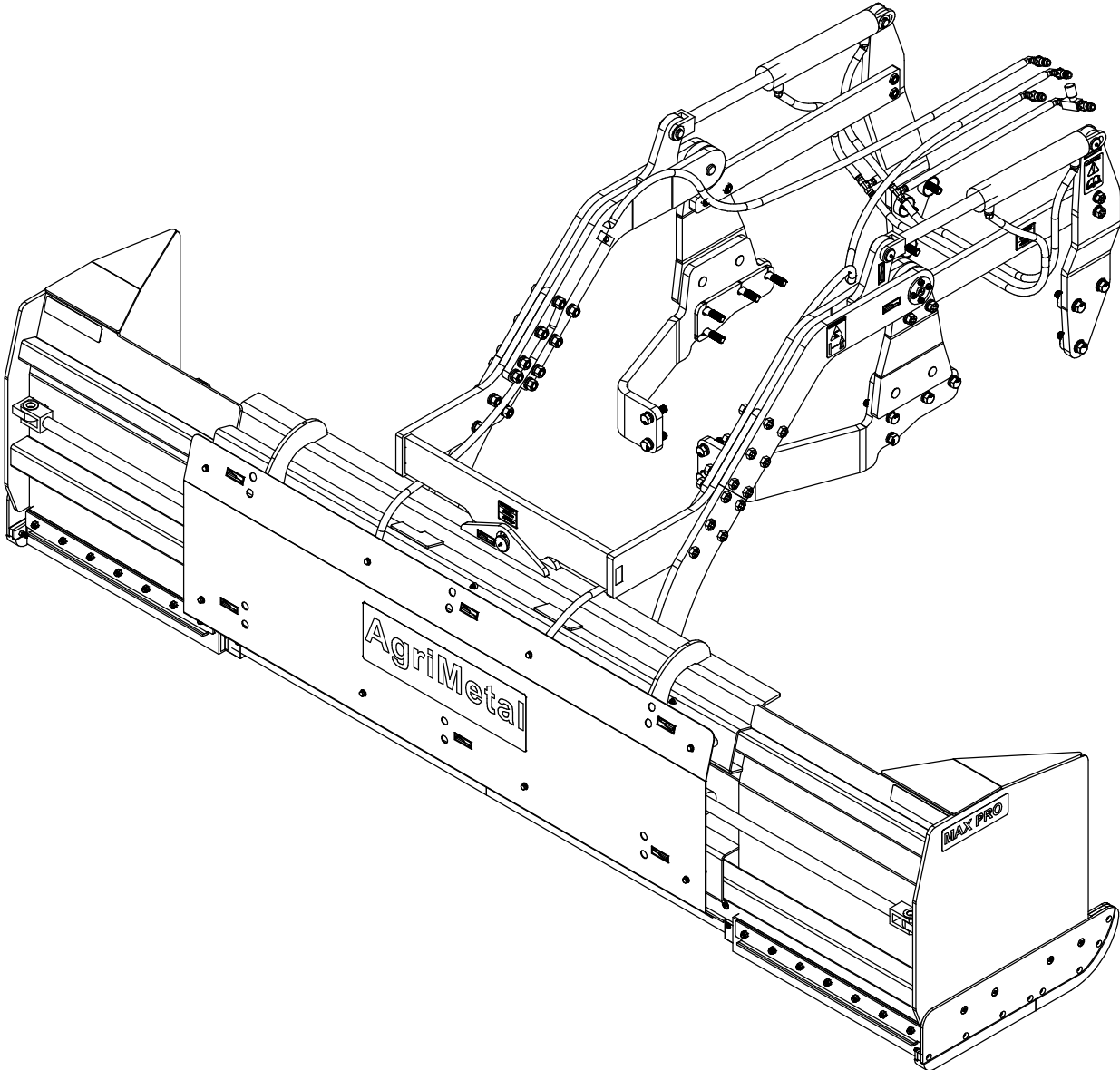

MAX PRO CASE 105U 7-12H B

#	PART #	Qty	TITLE
1	91-50-0052	1	INSIDE KNIFE RIGHT
2	91-50-0057	1	INSIDE KNIFE LEFT
3	NC02-48-0547	32	FLAT HEAD SOCKET CAP SCREW STAINLESS 1/2-13 X 1 3/4
4	NC01-96-0014	32	NYLON INSERT LOCKNUT 1/2-13"
5	91-20-0388	2	OUTSIDE KNIFE

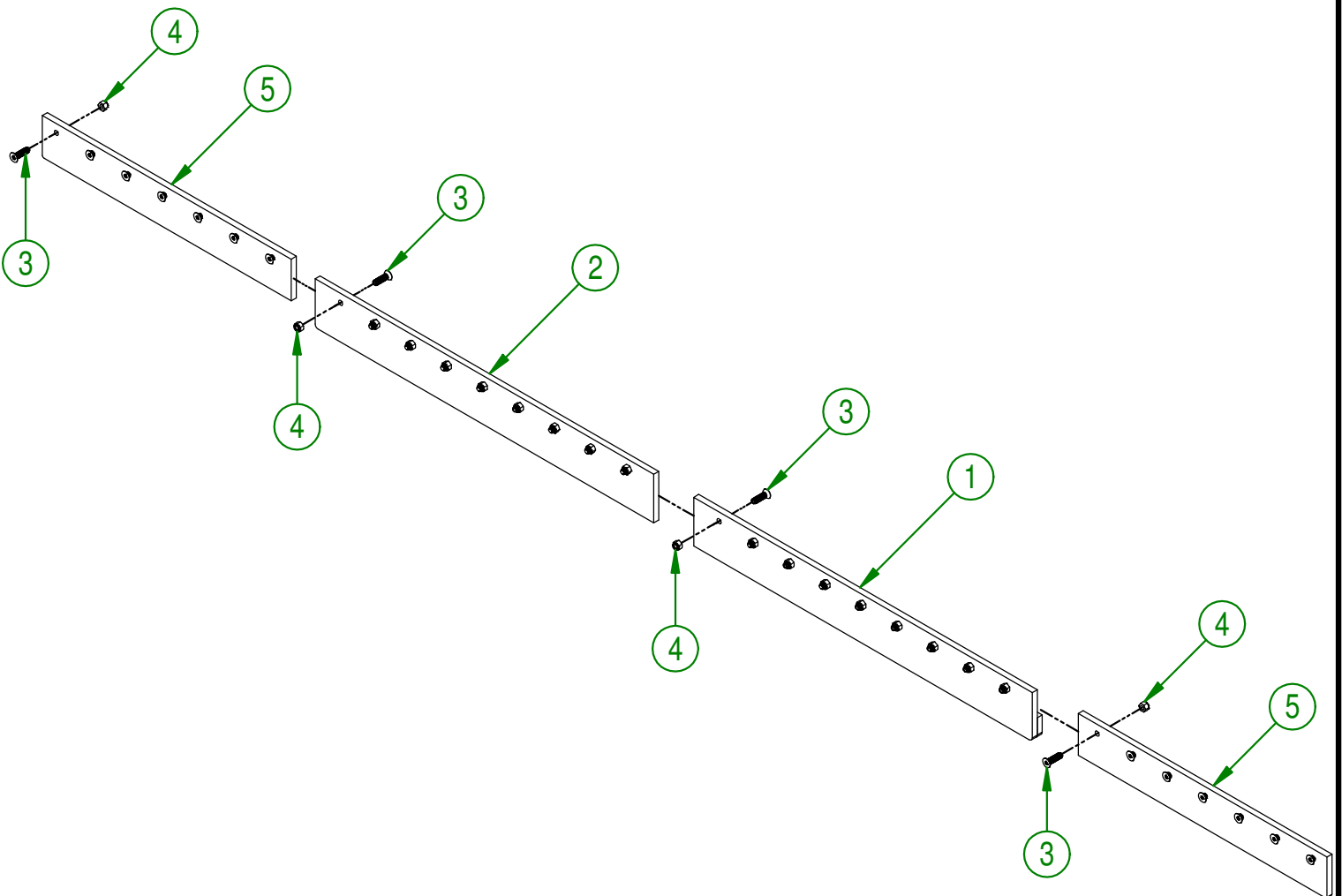

AGRIMETAL			
QT KNIFE GROUP			
CREATION : 04/05/17	ASSEMBLY :	91-57-0201	
REVISION : 29/12/17	AUTHOR : J.H.	Page 1 de 12	

#	PART #	Qty	TITLE
1	91-42-0013	1	RUBBER KNIFE (OUTSIDE LEFT)
2	91-04-0246	2	KNIFE BRACE (OUTSIDE)
3	NC02-48-0548	32	FLAT HEAD SOCKET CAP SCREW STAINLESS 1/2-13 X 2"
4	NC01-96-0014	32	NYLON-INSERT LOCKNUT ZINC 1/2-13
5	91-42-0003	1	RUBBER KNIFE (INSIDE RIGHT)
6	91-42-0121	2	SNOW GUARD
7	91-42-0000	1	RUBBER KNIFE (INSIDE LEFT)
8	91-20-0150	18	WASHER
9	NC02-48-0582	4	FLAT HEAD SOCKET CAP SCREW STAINLESS 1/4-20 X 2"
10	NC01-96-0009	4	NYLON-INSERT LOCKNUT ZINC 1/4-20
11	91-04-0241	1	KNIFE BRACE (RIGHT)
12	91-04-0244	1	KNIFE BRACE (LEFT)
13	91-42-0010	1	RUBBER KNIFE (OUTSIDE RIGHT)

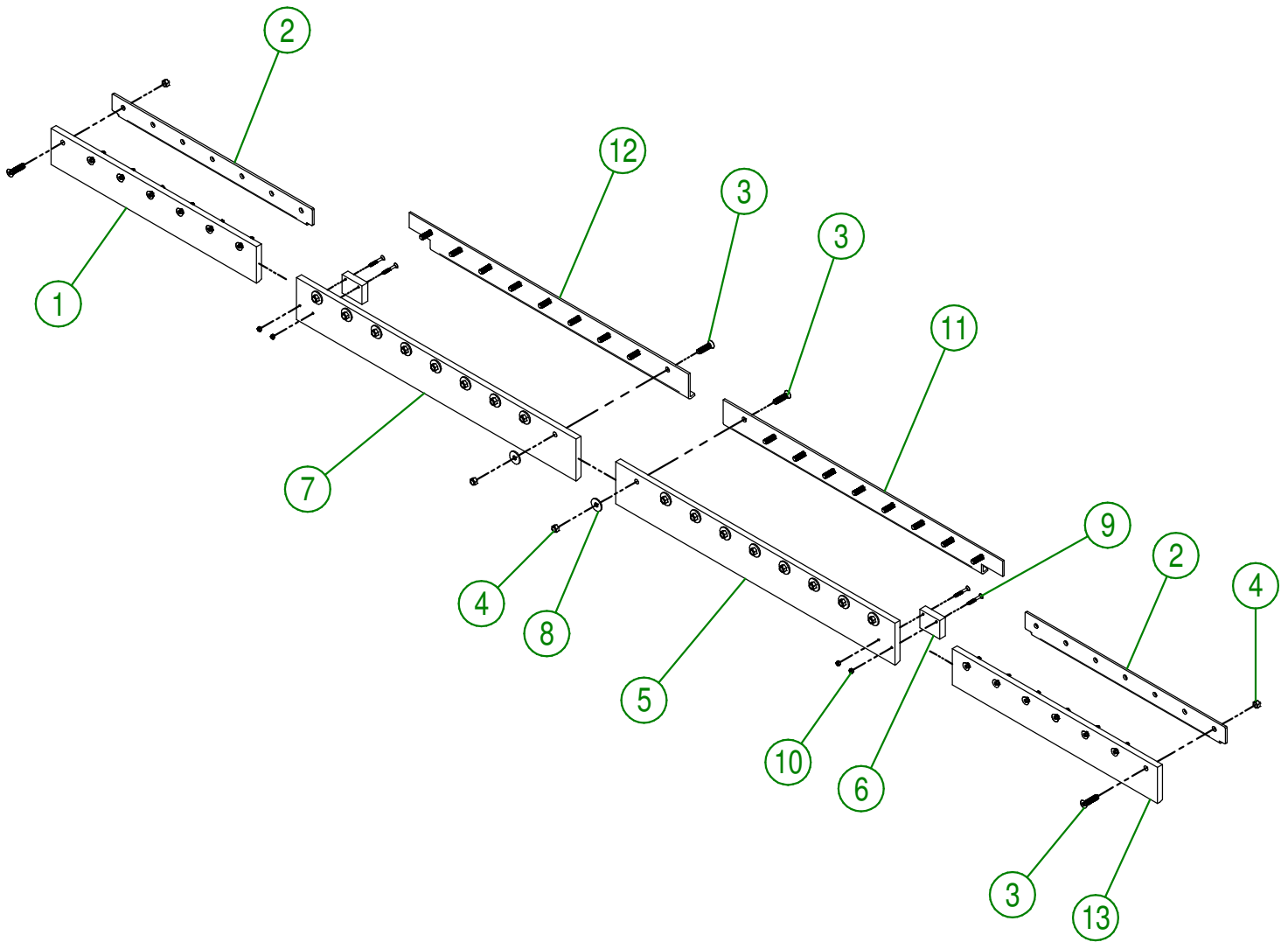

AGRIMETAL
RUBBER KNIFE GROUP

CREATION : 10/05/17
REVISION : 05/02/21

ASSEMBLY : **91-57-0195**
AUTHOR : J. Houle

#	PART #	Qty	TITLE
1	91-42-0147	2	OUTSIDE KNIFE (UHMW)
2	91-04-0246	2	KNIFE BRACE (OUTSIDE)
3	NC02-48-0549	14	STAINLESS FLAT HEAD SOCKET CAP SCREW 1/2-13 X 2 1/4"
4	NC01-96-0014	32	NYLON-INSERT LOCKNUT ZINC 1/2-13
5	91-42-0133	2	CENTER KNIFE (UHMW)
6	91-42-0121	2	SNOW GUARD
7	NC02-48-0550	18	FLAT HEAD SOCKET CAP SCREW STAINLESS 1/2-13 X 2 1/2"
8	91-20-0150	18	WASHER
9	NC02-48-0582	4	FLAT HEAD SOCKET CAP SCREW STAINLESS 1/4-20 X 2"
10	NC01-96-0009	4	NYLON-INSERT LOCKNUT ZINC 1/4-20
11	91-04-0241	1	KNIFE BRACE (RIGHT)
12	91-04-0244	1	KNIFE BRACE (LEFT)

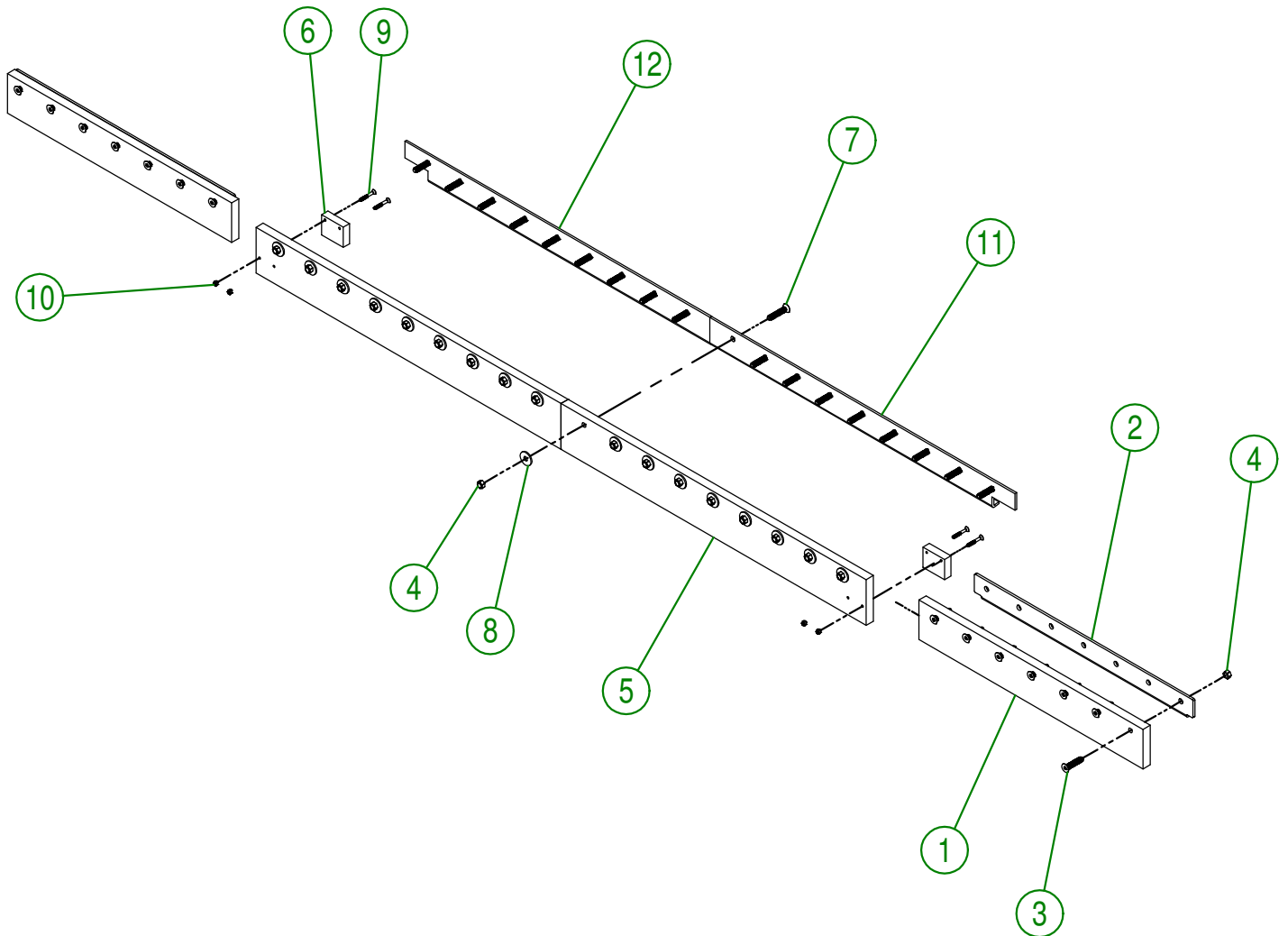

AGRIMETAL	
UHMW KNIFE GROUP	
CREATION : 05-05-2017	ASSEMBLY : 91-57-0206
REVISION : 09-11-2018	AUTHOR : Dessin1 Page 3 de 12

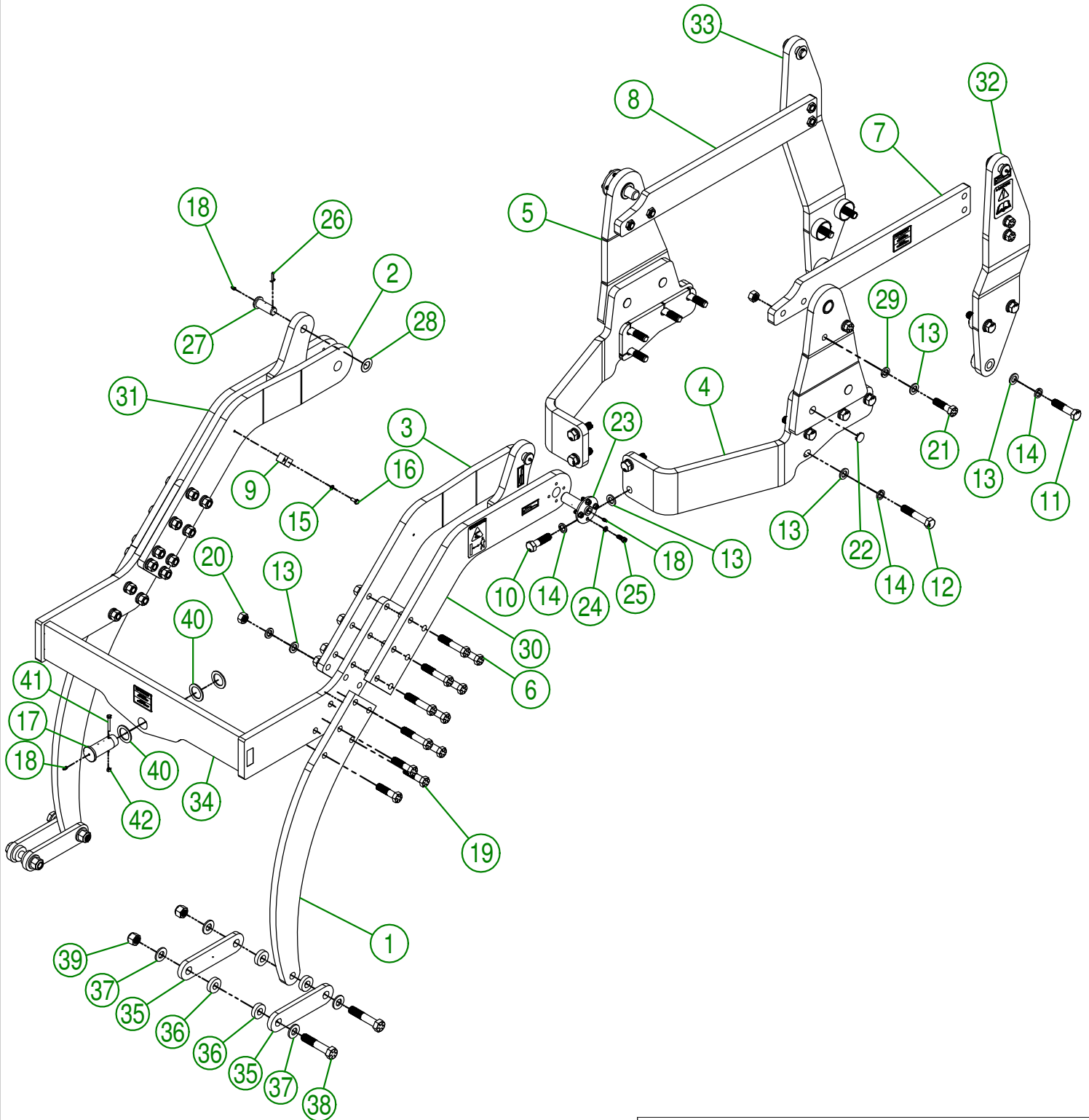

AGRIMETAL	
SUBFRAME U105 GROUP	
CREATION : 26-10-2016	ASSEMBLY : 91-57-0285
REVISION : 08-02-2019	AUTHOR : JA. H. Page 4 de 12

#	PART #	Qty	TITLE
1	91-04-2050	2	SUBFRAME SECTION
2	91-04-2047	1	SUBFRAME SECTION
3	91-04-2045	1	SUBFRAME SECTION
4	91-50-0140	1	SUBFRAME SECTION
5	91-50-0130	1	SUBFRAME SECTION
6	NC01-37-0460	16	HEX. BOLT GR8 ZINC 3/4-16 X 4
7	91-57-0530	1	LEFT BRACE GROUP "STICKER INCLUDED"
8	91-57-0535	1	RIGHT BRACE GROUP. "STICKER INCLUDED"
9	91-01-0020	2	HYDRAULIC HOSE PROTECTOR
10	NC01-50-1100	4	BOLT 10.9 NF 20 MM X 70 MM
11	NC01-50-1105	6	BOLT 10.9 NF 20 MM X 90 MM
12	NC01-50-1110	8	BOLT 10.9 NF 20 MM X 110 MM
13	NC02-22-0016	48	WASHER ZINC 3/4"
14	NC02-32-0030	22	LOCK WASHER ZINC 20 MM
15	NC02-32-0011	2	LOCK WASHER ZINC 5/16"
16	NC01-17-0058	2	HEX. BOLT GR2 ZINC 5/16-18 X 3/4"
17	91-13-2800	1	CENTER PIVOT SHAFT
18	NC01-69-0785	7	STRAIGHT GREASE FITTING 1/4-28
19	NC01-37-0455	6	HEX. BOLT GR8 ZINC 3/4-16 X 3
20	NC02-10-0023	30	HEX NUT 3/4-16
21	NC01-37-0450	8	HEX. BOLT GR8 ZINC 3/4-16 X 2 3/4
22	NC13-80-0273	8	BLACK CAP 1" DIA
23	91-50-0145	2	SUBFRAME PIVOT
24	NC02-32-0012	8	LOCK WASHER ZINC 3/8"
25	NC01-37-0114	8	BOLT GR8 3/8" X 1"
26	NC01-69-0159	4	COTTER PIN ZINC 3/16 X 1 1/2"
27	91-20-0210	4	CYLINDER PIVOT
28	91-22-2200	4	FLAT WASHER HYDRAULIC CYLINDER
29	NC02-32-0017	26	LOCK WASHER ZINC 3/4"
30	91-57-0295	1	SUBFRAME SECTION GROUP
31	91-57-0300	1	SUBFRAME SECTION GROUP
32	91-57-0305	1	SUBFRAME SECTION GROUP
33	91-57-0310	1	SUBFRAME SECTION GROUP
34	91-57-0525	1	FRONT SUBFRAME " STICKER INCLUDED"
35	91-04-1420	4	BLADE CONNECTOR
36	NC13-15-0319	8	RUBBER WASHER
37	09-04-0050	8	PNO 3/16" X 1 49/64" DIA. X Ø 7/8" FLAT WASHER
38	NC01-33-0506	4	CAP SCREW GR8 NC ZINC 7/8-9 X 4 1/2" LG
39	NC01-96-0018	4	NYLON INSERT NUT 7/8-9
40	92-01-0005	3	WASHER 2 1/4" DIA. X 1 9/16"
41	NC01-17-0010	1	HEX. BOLT GR2 NC ZINC 1/4-20 X 2"
42	NC01-93-0001	1	HEX. NUT NC ZINC 1/4-20

AGRIMETAL**SUBFRAME U105 GROUP**

CREATION : 26-10-2016

ASSEMBLY : 91-57-0285

REVISION : 08-02-2019

AUTHOR : JA. H.

Page 5 de 12

#	PART #	Qty	TITLE
1	91-57-0241	1	CENTRAL BLADE (WITH STICKER)
2	NC01-69-0791	12	GREASE FITTING 1/8 NPT STRAIGHT
3	91-57-0500	1	HYDRAULIC CYLINDER GUARD
4	01-01-2485	8	FLAT WASHER 14 GA X 13/16"OD X 25/64" ID
5	NC02-32-0012	8	LOCK WASHER ZINC 3/8"
6	NC01-17-0112	8	HEX. BOLT GR2 ZINC 3/8-16 X 3/4"

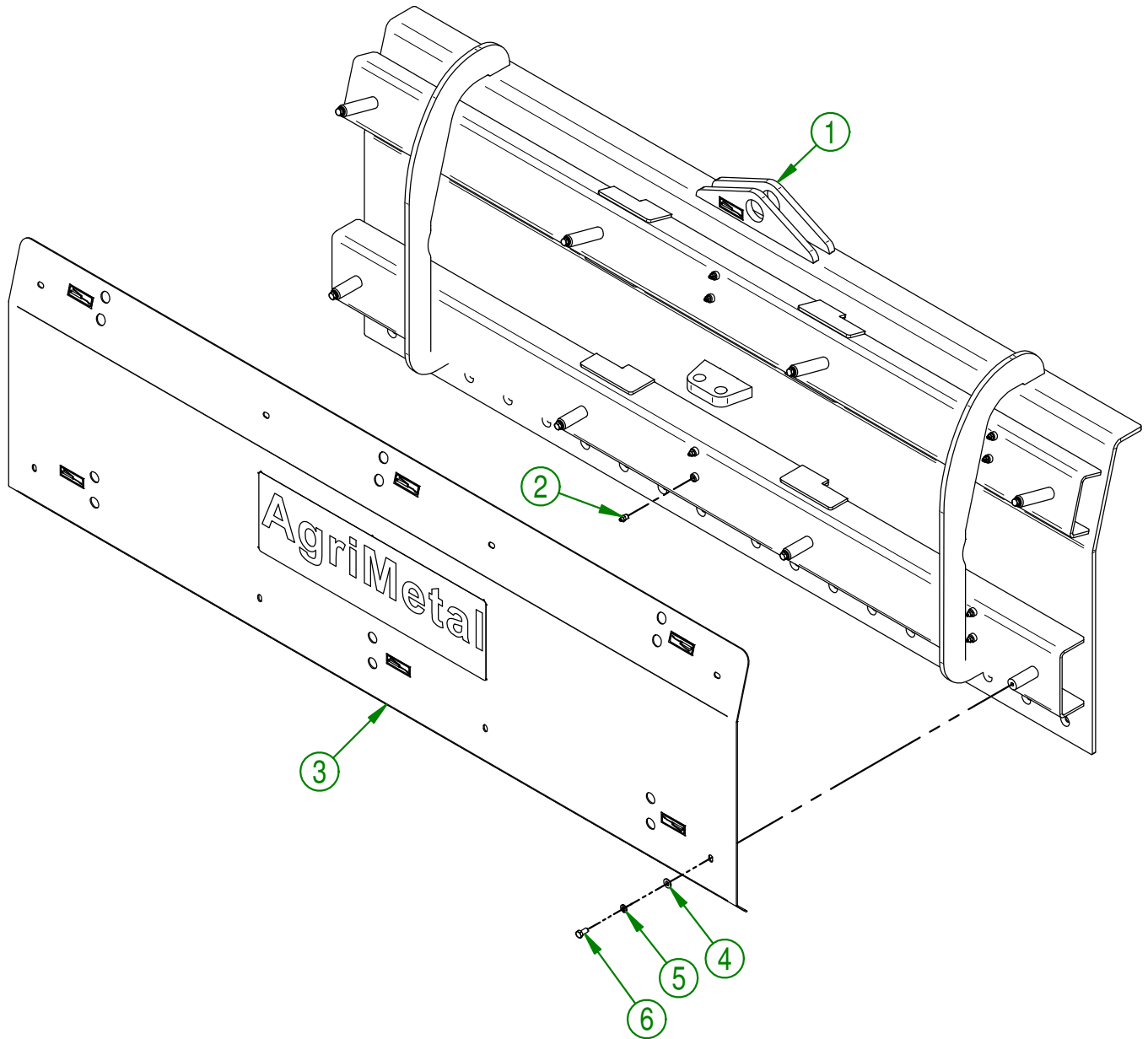

AGRIMETAL	
SNOW BLADE GROUP	
CREATION : 23/03/18	ASSEMBLY : 91-57-0271
REVISION : 15/10/18	AUTHOR : J.KABWE Page 6 de 12

#	PART #	Qty	TITLE
1	91-57-0251	1	RIGHT BLADE (WITH STICKER)
2	NC13-15-0325	1	FLOATING SKATE (MIDDLE FRONT)
3	NC13-15-0324	1	FLOATING SKATE (MIDDLE BACK)
4	91-09-0000	4	BUSHING
5	91-42-0185	1	FLOATING SKATE (RIGHT OUTSIDE)
6	91-42-0180	1	FLOATING SKATE (RIGHT INT.)
7	NC13-86-0052	2	SPRING 1/2" ID X 1" OD X 5" LG
8	NC02-48-0549	4	STAINLESS FLAT HEAD SOCKET CAP SCREW 1/2-13 X 2 1/4"
9	NC02-48-0537	8	STAINLESS FLAT HEAD SOCKET CAP SCREW 3/8-16 X 2 1/4"
10	91-20-0150	4	WASHER
11	91-20-0163	2	WASHER
12	91-20-0160	6	WASHER
13	NC01-96-0011	8	NYLON NUT 3/8-16
14	NC01-96-0014	4	NYLON-INSERT LOCKNUT ZINC 1/2-13

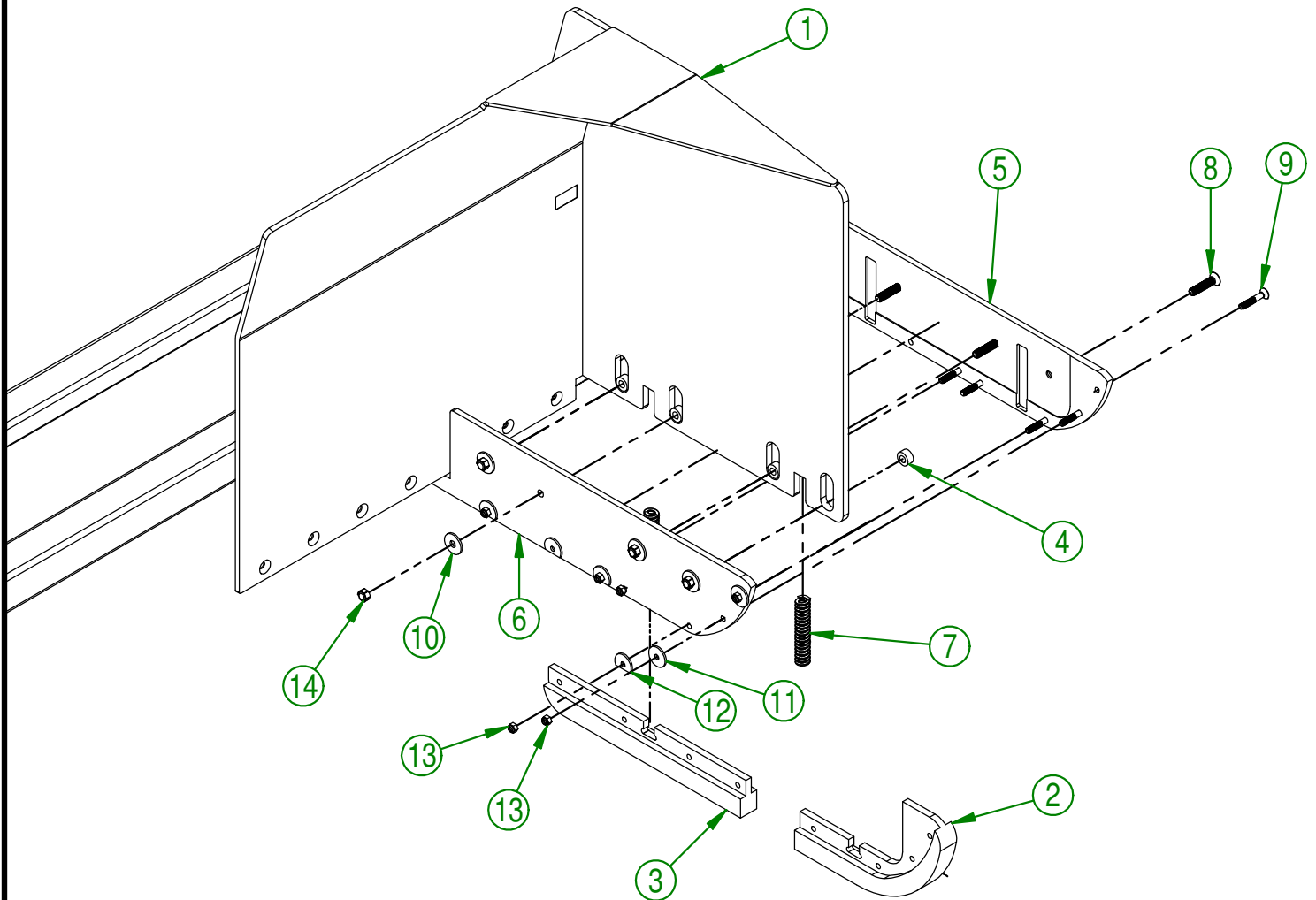

IMPORTANT

USE THIS PARTS ONLY IF YOUR SERIAL NUMBER IS INVOLVED:

#37424 OR UNDER

AGRIMETAL RIGHT BLADE GROUP

CREATION : 18/01/18
REVISION : 09/01/19

ASSEMBLY : **91-57-0256**

AUTHOR : J.KABWE

Page 7 de 12

#	PART #	Qty	TITLE
1	91-57-0251	1	RIGHT BLADE (WITH STICKER)
2	91-42-0138	1	FLOATING SKATE (MIDDLE FRONT)
3	91-42-0175	1	FLOATING SKATE (MIDDLE BACK)
4	91-09-0000	4	BUSHING
5	91-42-0410	1	FLOATING SKATE (RIGHT OUTSIDE)
6	NC13-86-0052	2	SPRING 1/2" ID X 1" OD X 5" LG
7	NC02-48-0548	4	FLAT HEAD SOCKET CAP SCREW STAINLESS 1/2-13 X 2"
8	NC02-48-0535	8	STAINLESS FLAT HEAD SOCKET CAP SREW 3/8-16 X 1 3/4
9	NC01-96-0011	8	NYLON NUT 3/8-16
10	NC01-96-0014	4	NYLON-INSERT LOCKNUT ZINC 1/2-13
11	91-50-0370	1	FLOATING SKATE (RIGHT INT.)

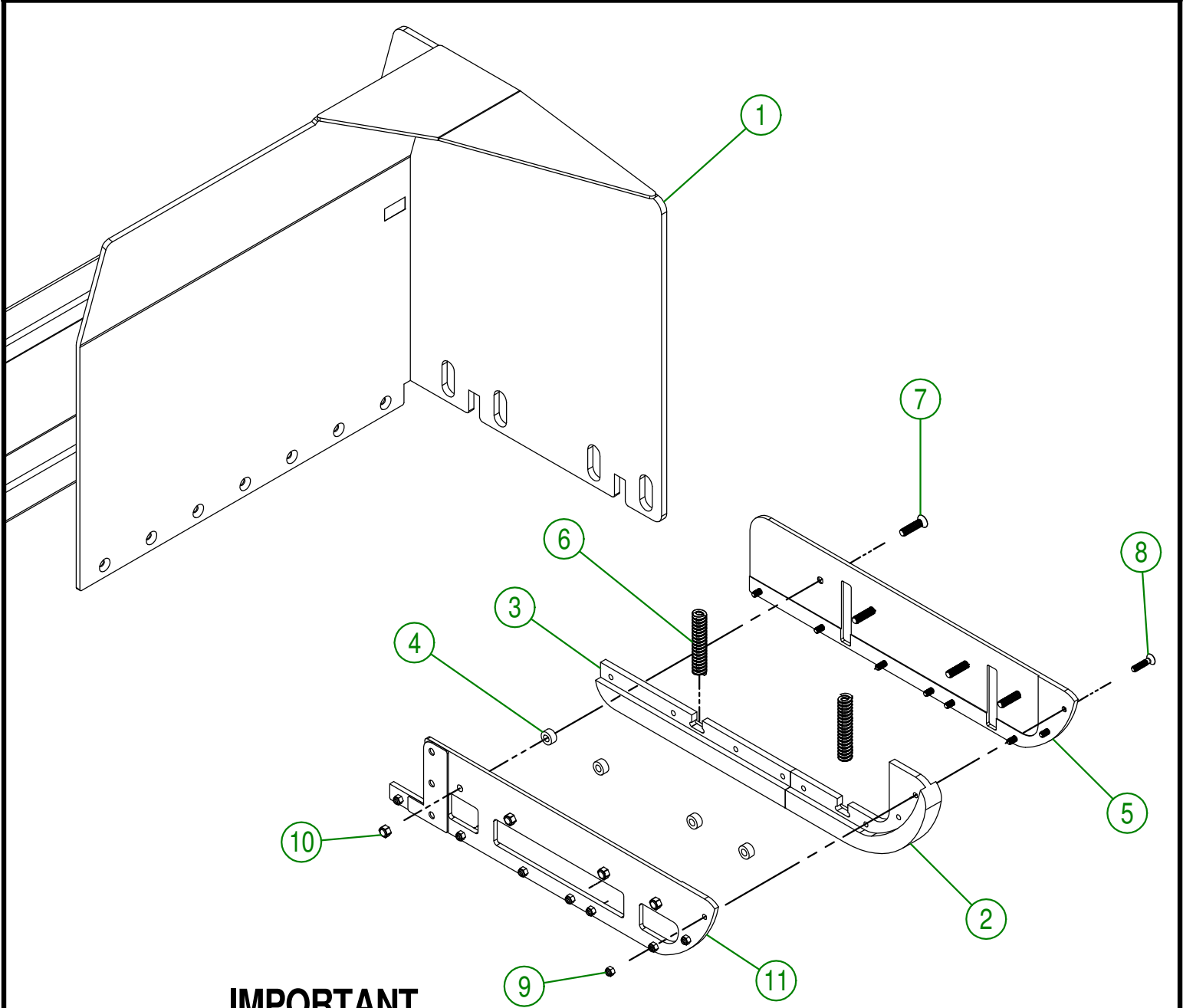

IMPORTANT

USE THIS PARTS ONLY IF YOUR SERIAL NUMBER IS INVOLVED:

#37430 OR ABOVE

AGRIMETAL
RIGHT BLADE GROUP

CREATION : 05/11/18
REVISION : 25/10/19

ASSEMBLY : **91-57-0257**

AUTHOR : J. Houle

Page 8 de 12

#	PART #	Qty	TITLE
1	91-57-0261	1	LEFT BLADE (WITH STICKER)
2	NC13-15-0324	1	FLOATING SKATE (MIDDLE BACK)
3	91-42-0165	1	FLOATING SKATE (RIGHT INT.)
4	91-42-0160	1	FLOATING SKATE (RIGHT MIDDLE)
5	91-09-0001	4	BUSHING
6	NC13-86-0052	2	SPRING 1/2" ID X 1" OD X 5" LG
7	NC02-48-0537	8	STAINLESS FLAT HEAD SOCKET CAP SCREW 3/8-16 X 2 1/4"
8	NC02-48-0549	4	STAINLESS FLAT HEAD SOCKET CAP SCREW 1/2-13 X 2 1/4"
9	91-20-0150	4	WASHER
10	91-20-0163	2	WASHER
11	91-20-0160	6	WASHER
12	NC01-96-0014	4	NYLON-INSERT LOCKNUT ZINC 1/2-13
13	NC01-96-0011	8	NYLON NUT 3/8-16
14	NC13-15-0325	1	FLOATING SKATE (MIDDLE FRONT)

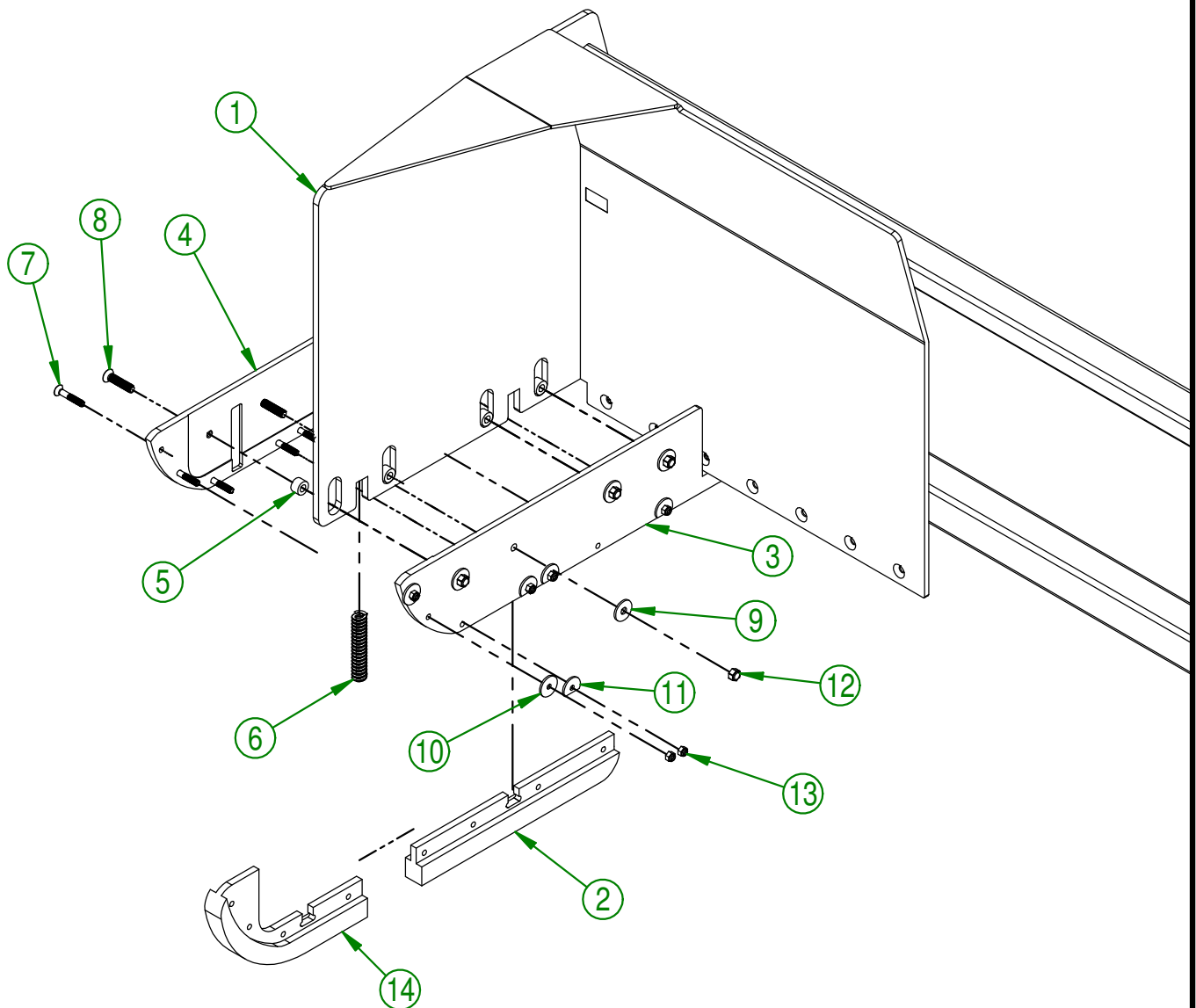

IMPORTANT

USE THIS PARTS ONLY IF YOUR SERIAL NUMBER IS INVOLVED:

#37424 OR UNDER

AGRIMETAL
LEFT BLADE GROUP

CREATION : 18/01/18
REVISION : 09/01/19

ASSEMBLY : **91-57-0266**

AUTHOR : J.KABWE

Page 9 de 12

#	PART #	Qty	TITLE
1	91-57-0261	1	LEFT BLADE (WITH STICKER)
2	91-42-0175	1	FLOATING SKATE (MIDDLE BACK)
3	91-42-0413	1	FLOATING SKATE (RIGHT MIDDLE)
4	91-09-0001	4	BUSHING
5	NC13-86-0052	2	SPRING 1/2" ID X 1" OD X 5" LG
6	NC02-48-0535	8	STAINLESS FLAT HEAD SOCKET CAP SREW 3/8-16 X 1 3/4
7	NC02-48-0548	4	FLAT HEAD SOCKET CAP SCREW STAINLESS 1/2-13 X 2"
8	NC01-96-0014	4	NYLON-INSERT LOCKNUT ZINC 1/2-13
9	NC01-96-0011	8	NYLON NUT 3/8-16
10	91-42-0138	1	FLOATING SKATE (MIDDLE FRONT)
11	91-50-0365	1	FLOATING SKATE (RIGHT INT.)

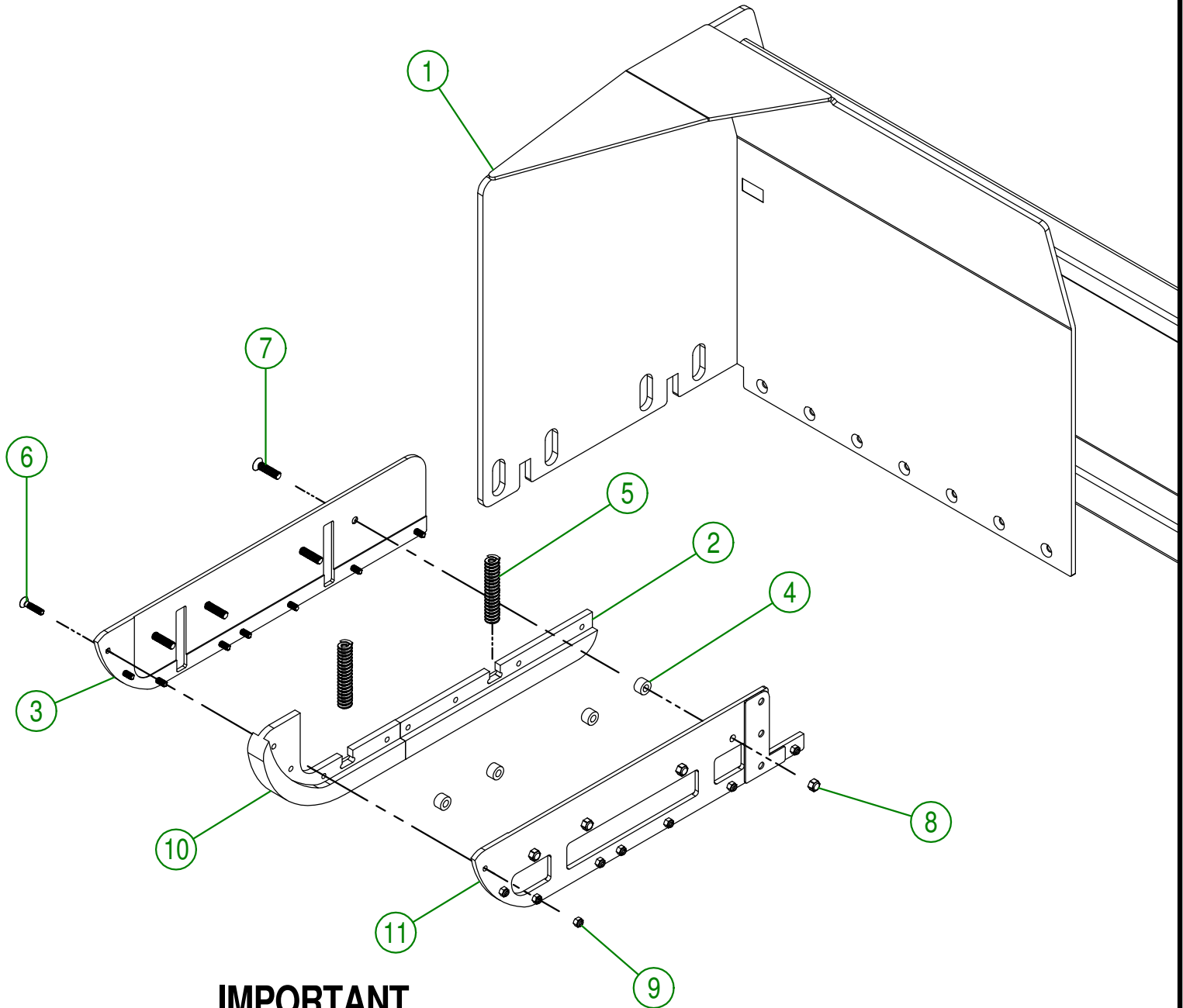

IMPORTANT

USE THIS PARTS ONLY IF YOUR SERIAL NUMBER IS INVOLVED:

#37430 OR ABOVE

AGRIMETAL
LEFT BLADE GROUP

CREATION : 05/11/18
REVISION : 28/10/19

ASSEMBLY : **91-57-0267**

AUTHOR : J. Houle Page 10 de 12

#	PART #	Qty	TITLE
1	NC13-45-0240	1	HYDRAULIC CYLINDER 2" X 30" STROKE
2	NC13-45-0239	1	HYDRAULIC CYLINDER 2 1/2" X 30" STROKE
3	NC13-45-0254	3	90 DEG ELBOW 9/16"-18 MALE SAE6 O RING X 3/8" MALE JIC
4	NC13-45-0294	5	ELBOW 45 DEG 9/16-18 MÂLE O RING X 3/8 MÂLE JIC
5	NC17-02-0393	1	HYDRAULIC HOSE 232"
6	NC13-45-0014	4	QUICK COUPLER 1/2-14 NPTF
7	NC17-02-0394	1	HYDRAULIC HOSE 244"
8	NC13-45-0257	2	HYDRAULIC CYLINDER 2 1/2" X 12" STROKE
9	NC13-45-0247	3	STRAIGHT FITTING 1/2" MALE NPT X 3/8" MALE JIC
10	NC17-02-0353	1	HYDRAULIC HOSE 39 3/4"
11	NC17-02-0395	1	HYDRAULIC HOSE 54"
12	NC13-45-0289	2	T 3/8 MALE JIC X 3/8 MALE JIC X 3/8 MALE JIC
13	NC17-02-0396	1	HYDRAULIC HOSE 41"
14	NC17-02-0399	2	HYDRAULIC HOSE 112"
15	NC17-02-0397	1	HYDRAULIC HOSE 57"
16	NC17-02-0396	1	HYDRAULIC HOSE 41"
17	NC13-45-0241	1	FLOW CONTROLE 3/8" NPT FEMALE
18	NC13-45-0246	1	HEX 1/2" MALE NPT X 3/8" MALE NPT
19	NC13-45-0288	1	STRAIGHT FITTING 1/2" MALE JIC X 3/8" MALE NPT
20	NC13-45-0173	4	90 DEG ELBOW
21	91-22-2200	8	FLAT WASHER HYDRAULIC CYLINDER

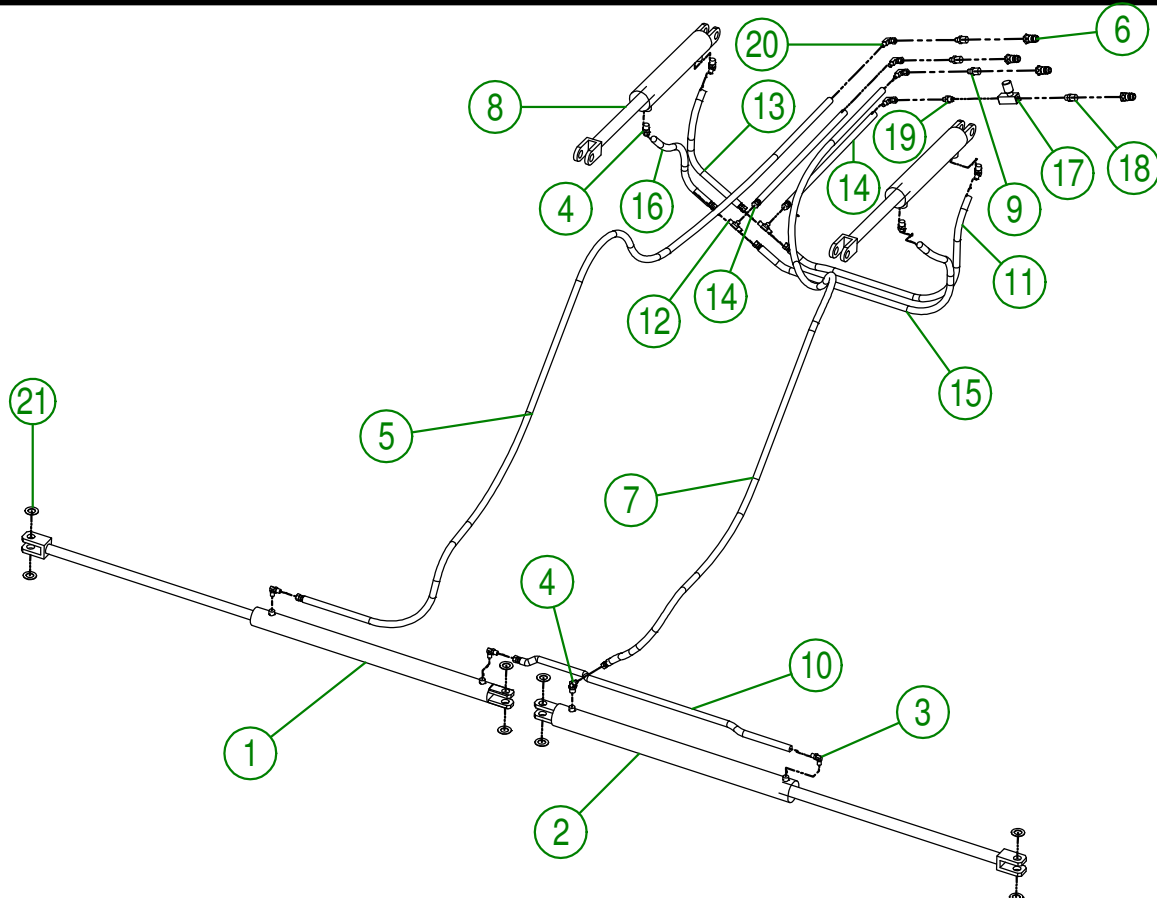

AGRIMETAL	
HYDRAULIC GROUP	
CREATION : 2016-10-26	ASSEMBLY : 91-57-0290
REVISION : 2018-01-17	AUTHOR : JA. H. Page 11 de 12

#	PART #	Qty	TITLE
1	NC13-33-0319	3	STICKER IMPORTANT GREASE EVERY 5 HOURS
2	NC13-33-0024	14	STICKER GREASE HERE
3	NC13-33-0268	2	STICKER WARNING
4	NC13-33-0183	2	STICKER CAUTION OPERATION MANUAL
5	NC13-33-0265	2	STICKER MAX PRO
6	28-60-0050	2	STICKER SCOTCHLITE
7	NC13-33-0318	1	STICKER AGRIMETAL INC (XL)

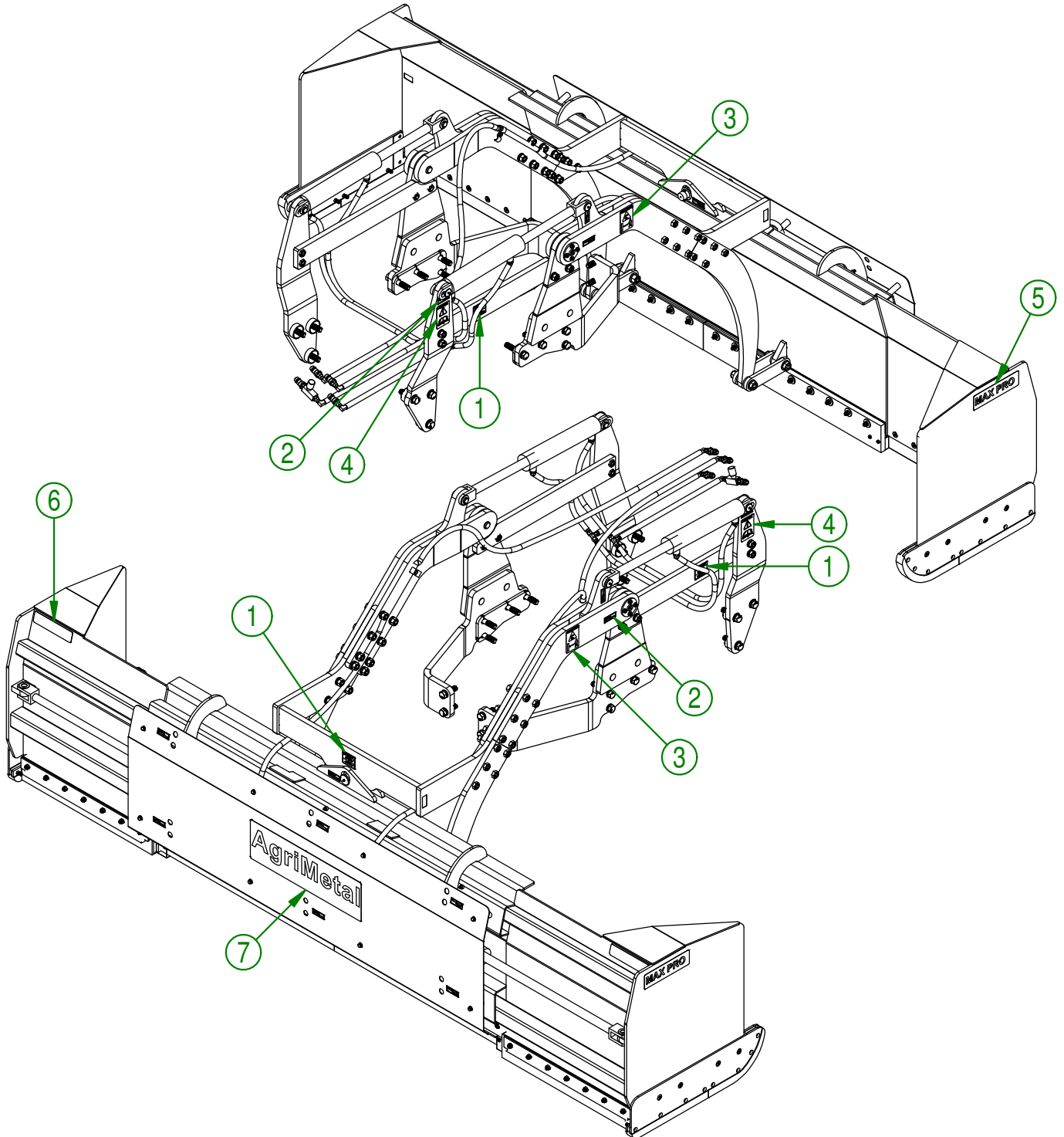

AGRIMETAL	
MAX PRO CASE 105U 7-12H	
CREATION : 19/01/18	ASSEMBLY : 91-99-1501
REVISION : 08/02/19	AUTHOR : J.KABWE Page 12 de 12