

AgriMetal

PARTS LIST

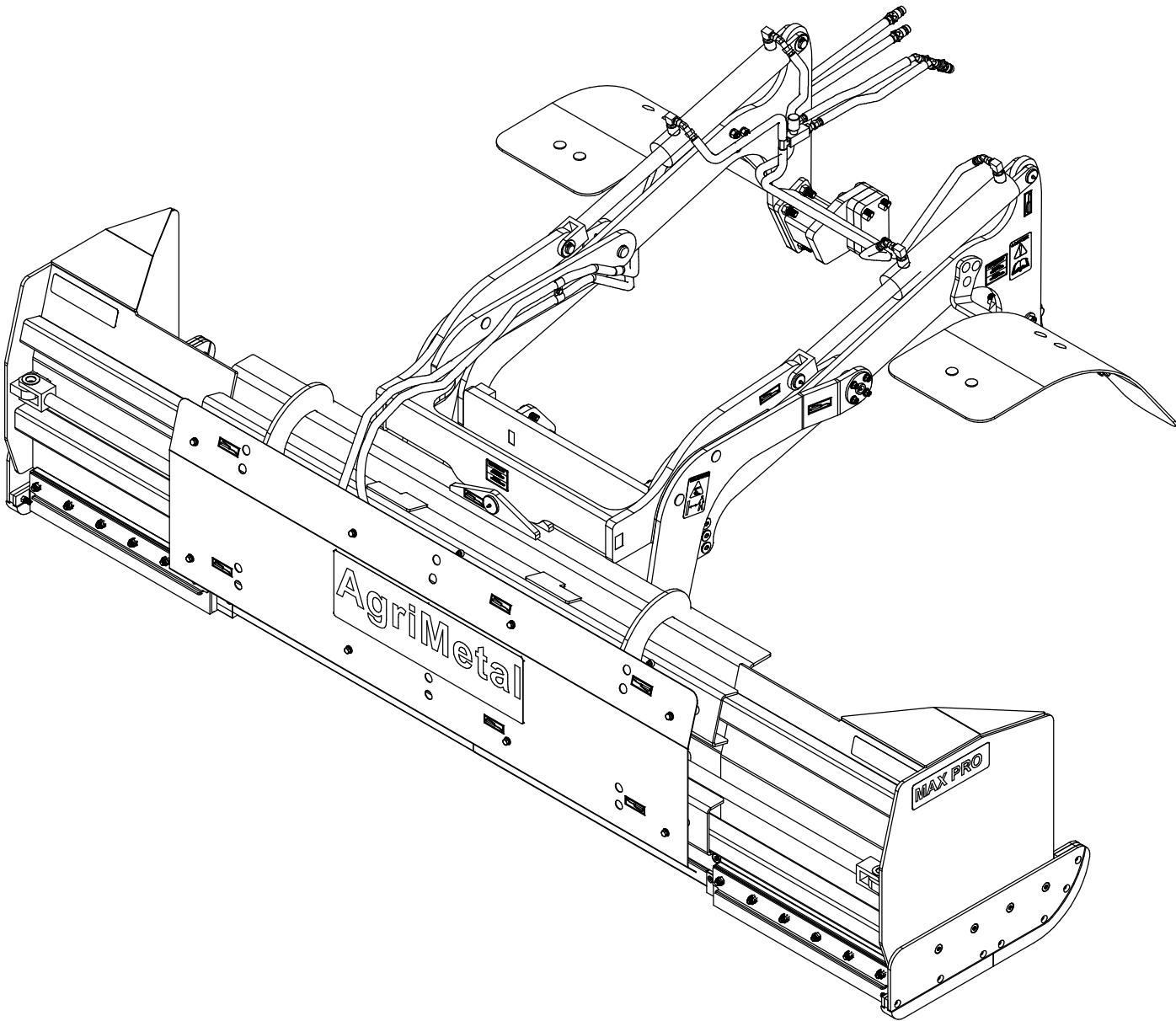

MAX-PRO 6-10 B (MAHINDRA 2555 HST)

#	PART #	Qty	TITLE
1	92-42-0003	1	INSIDE RUBBER KNIFE (RIGHT)
2	92-42-0000	1	INSIDE RUBBER KNIFE (LEFT)
3	92-04-0021	1	KNIFE BRACE (RIGHT)
4	92-04-0024	1	KNIFE BRACE (LEFT)
5	91-20-0150	16	WASHER
6	NC01-96-0014	28	NYLON INSERT LOCKNUT 1/2-13"
7	NC02-48-0548	28	FLAT HEAD SOCKET CAP SCREW STAINLESS 1/2-13 X 2"
8	92-42-0121	2	SNOW GUARD
9	NC02-48-0582	4	FLAT HEAD SOCKET CAP SCREW STAINLESS 1/4-20 X 2"
10	NC01-96-0009	4	NYLON-INSERT LOCKNUT ZINC 1/4-20
11	92-42-0005	2	OUTSIDE RUBBER KNIFE
12	92-04-0016	2	KNIFE BRACE (OUTSIDE)

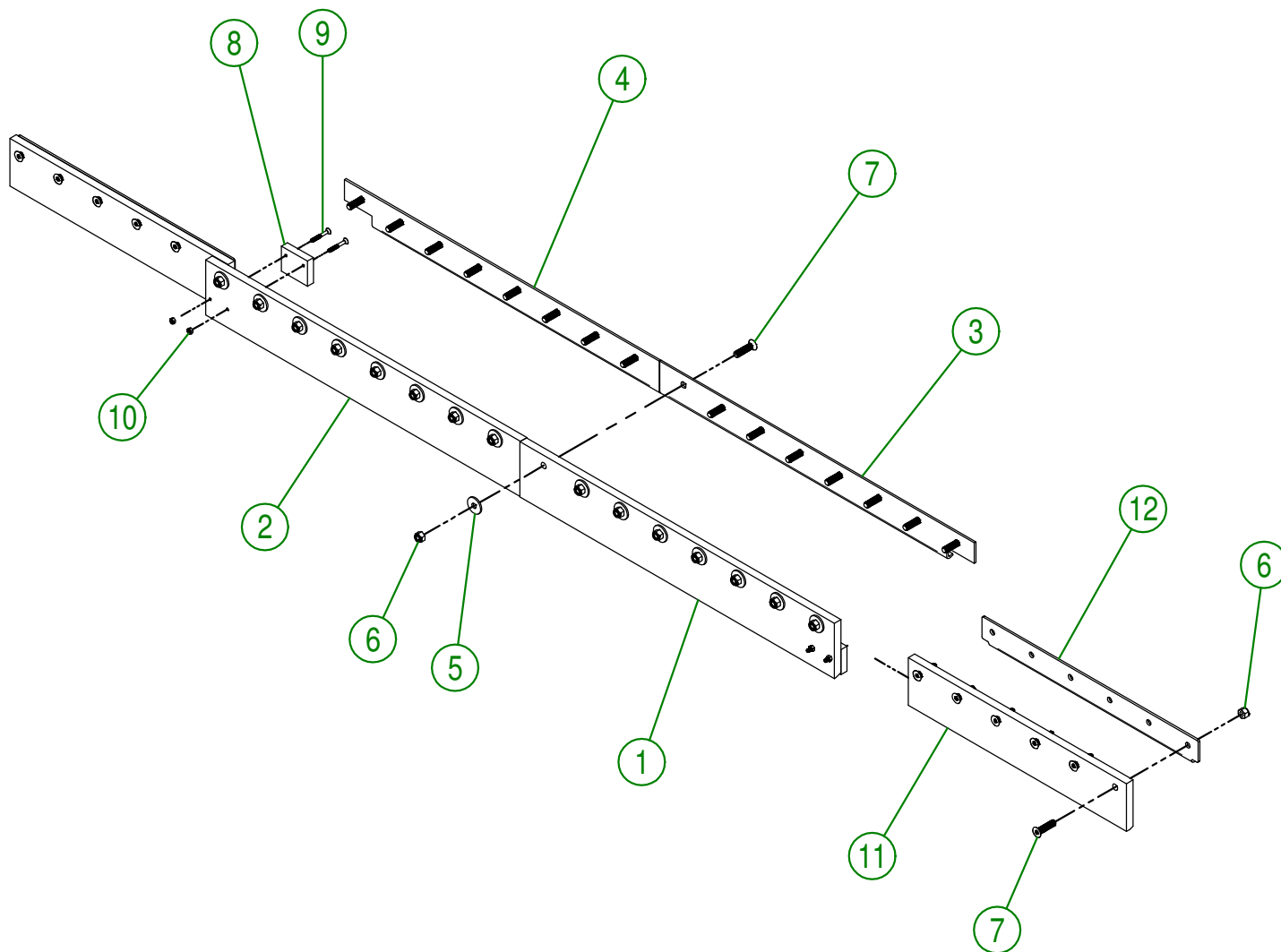

AGRIMETAL
RUBBER KNIFE GROUP

CREATION : 09/05/17
 REVISION : 29/12/17

ASSEMBLY : **92-57-0195**

AUTHOR : J. Houle

Page 1 de 14

#	PART #	Qty	TITLE
1	92-50-0052	1	RIGHT CENTER KNIFE
2	92-50-0057	1	LEFT CENTER KNIFE
3	NC01-96-0014	28	NYLON INSERT LOCKNUT 1/2-13"
4	NC02-48-0547	28	FLAT HEAD SOCKET CAP SCREW STAINLESS 1/2-13 X 1 3/4
5	92-20-0379	2	KNIFE SIDE QT 400

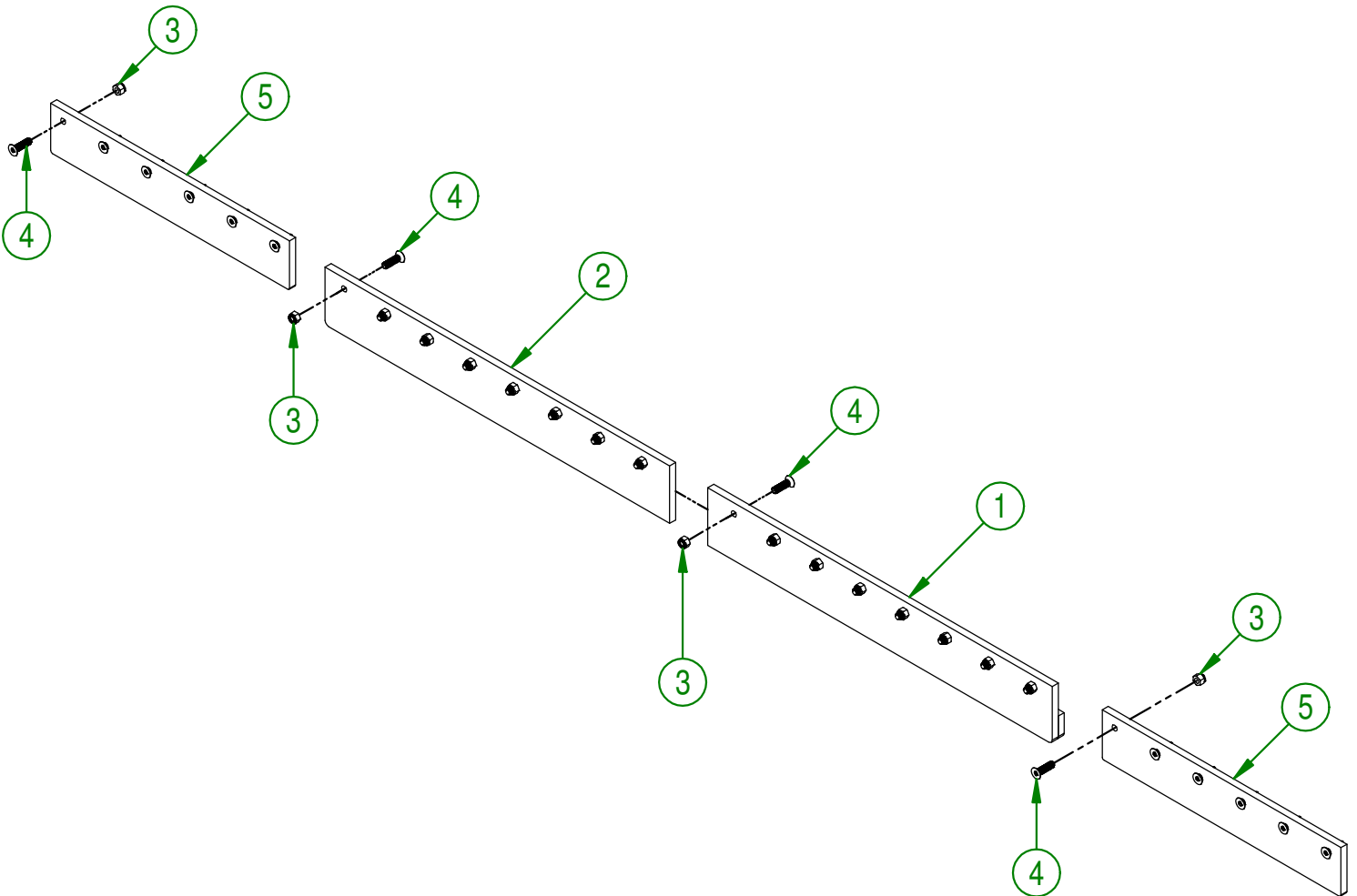

AGRIMETAL	
QT KNIFE GROUP	
CREATION : 09/05/17	ASSEMBLY : 92-57-0201
REVISION : 29/12/17	AUTHOR : J.H. Page 2 de 14

#	PART #	Qty	TITLE
1	92-42-0133	2	INSIDE KNIFE (UHMW)
2	92-04-0021	1	KNIFE BRACE (RIGHT)
3	92-04-0024	1	KNIFE BRACE (LEFT)
4	91-20-0150	16	WASHER
5	NC01-96-0014	28	NYLON INSERT LOCKNUT 1/2-13"
6	NC02-48-0549	28	STAINLESS FLAT HEAD SOCKET CAP SCREW 1/2-13 X 2 1/4"
7	92-42-0121	2	SNOW GUARD
8	NC02-48-0582	4	FLAT HEAD SOCKET CAP SCREW STAINLESS 1/4-20 X 2"
9	NC01-96-0009	4	NYLON-INSERT LOCKNUT ZINC 1/4-20
10	92-42-0149	2	OUTSIDE KNIFE (UHMW)
11	92-04-0016	2	KNIFE BRACE (OUTSIDE)

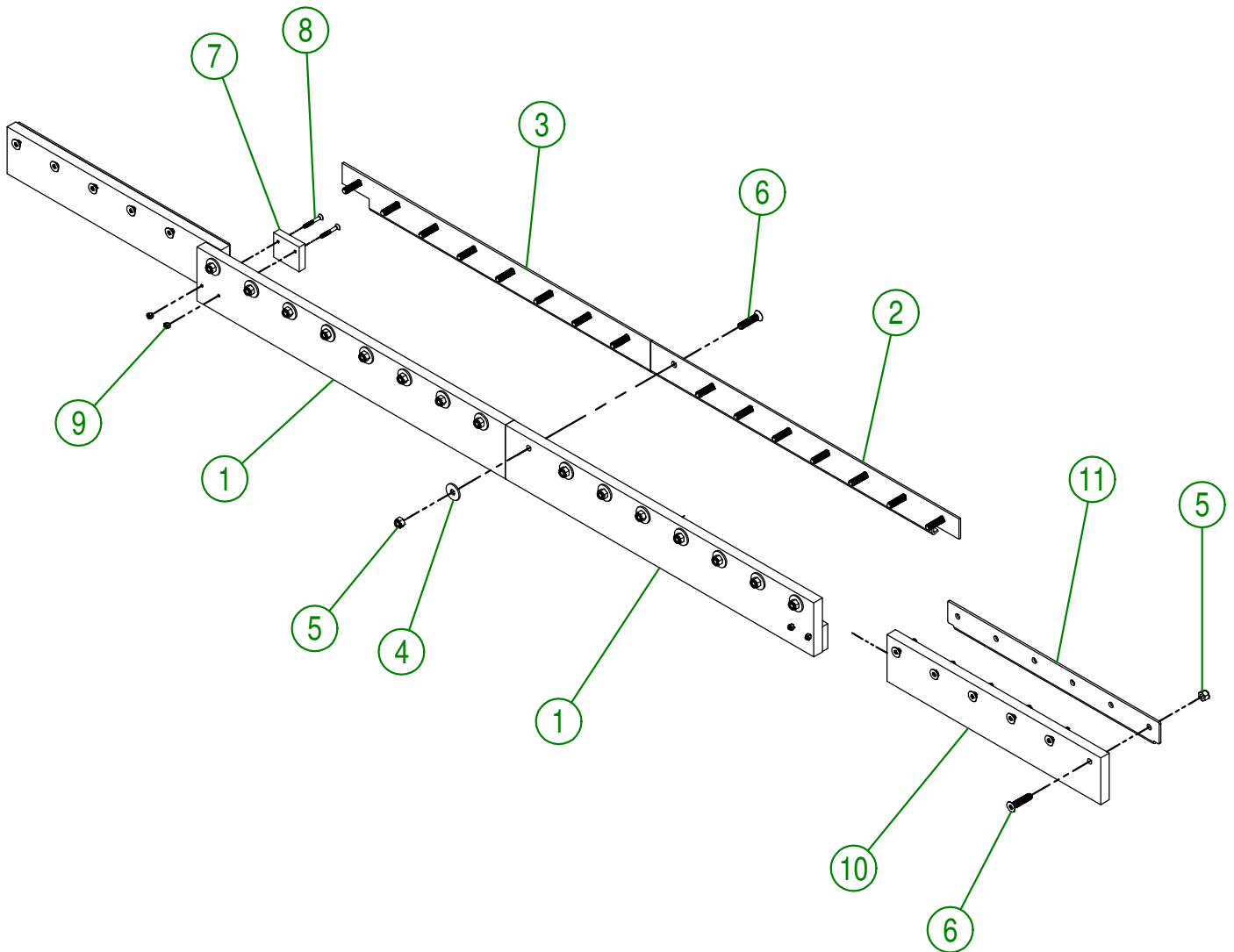

AGRIMETAL			
UHMW KNIFE GROUP			
CREATION : 09/05/17	ASSEMBLY :	92-57-0206	
REVISION : 09/11/18	AUTHOR : J.H.	Page 3 de 14	

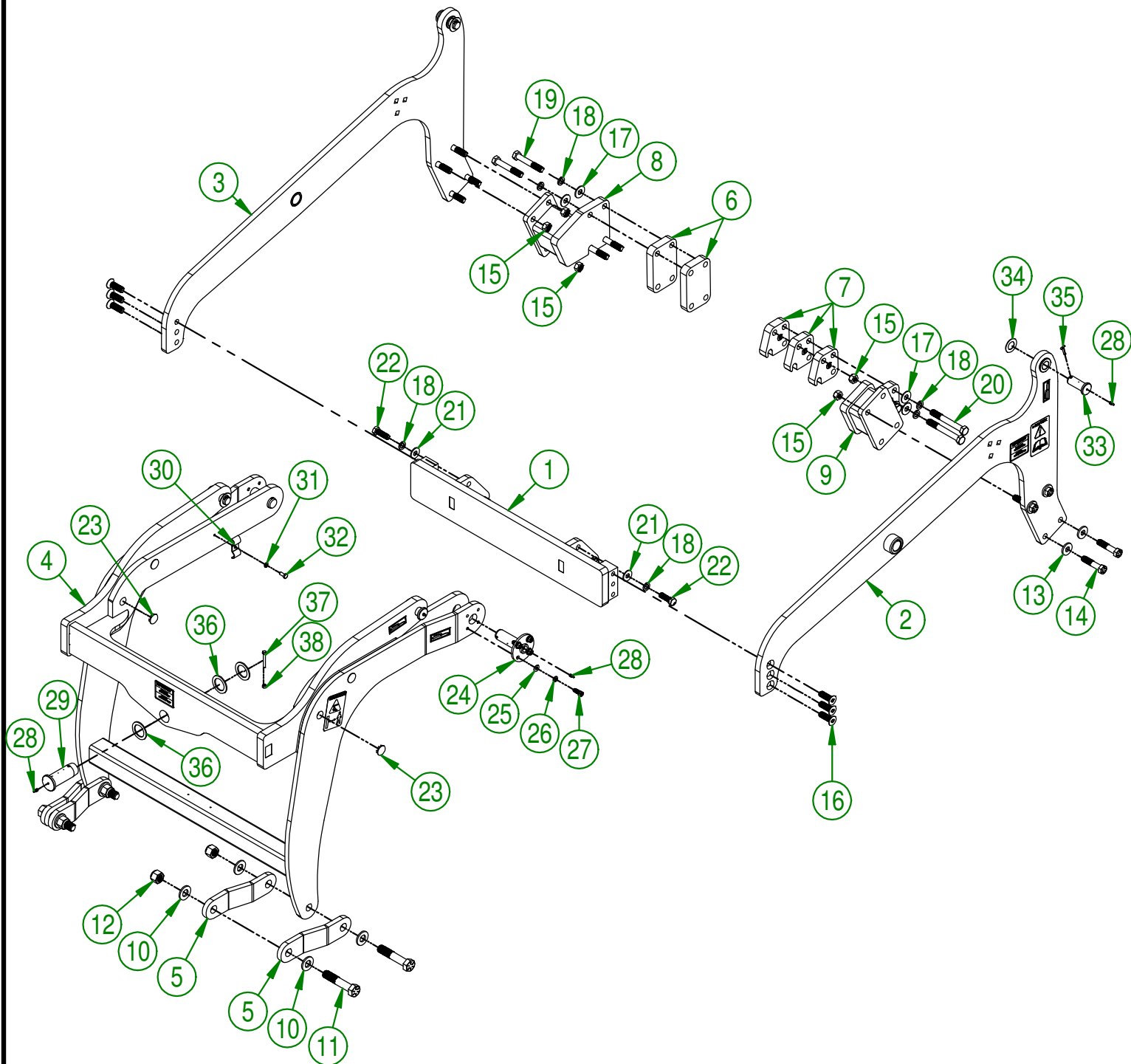

AGRIMETAL
SUBFRAME GROUP.

CREATION : 20/12/17
 REVISION : 15/02/19

ASSEMBLY : **91-57-0400**

AUTHOR : J.KABWE

Page 4 de 14

#	PART #	Qty	TITLE
1	91-50-0225	1	SUBFRAME FRONT PLATE
2	91-57-0435	1	FIXED FRAME STICKER INCLUDED (LEFT)
3	91-57-0430	1	FIXED FRAME STICKER INCLUDED (RIGHT)
4	91-57-0425	1	SUBFRAME MOBILE STICKER INCLUDED
5	91-04-1465	4	CONNECTOR
6	91-04-2125	2	FRAME SPACER (RIGHT)
7	91-04-2135	3	FRAME SPACER (LEFT)
8	91-50-0255	1	FIXED FRAME SUPPORT (RIGHT)
9	91-50-0260	1	FIXED FRAME SUPPORT (LEFT)
10	09-04-0050	8	PNO 3/16" X 1 49/64" DIA. X \varnothing 7/8" FLAT WASHER
11	NC01-33-0506	4	CAP SCREW GR8 NC ZINC 7/8-9 X 4 1/2" LG
12	NC01-96-0018	4	NYLON INSERT NUT 7/8-9
13	91-20-0155	8	FLAT WASHER
14	NC01-33-0400	8	CAP SCREW GR8 NC ZINC 5/8-11 X 3" LG
15	NC01-93-0016	8	LOCK NUT ZINC 5/8-11
16	NC02-48-0564	6	FLAT HEAD SOCKET CAP SCREW STAINLESS 5/8-11 X 2" LG
17	NC02-22-0013	8	WASHER ZINC 5/8 ID X 1 1/2 OD
18	NC02-32-0016	14	LOCK WASHER ZINC 5/8"
19	NC01-50-1115	4	BOLT METR. GR. 10.9 NC 16MM X 2THREAD X 100MM
20	NC01-50-1119	4	BOLT METR. GR. 10.9 NC 16MM X 2THREAD X 130MM
21	NC02-22-0012	6	WASHER ZINC 1/2 BOLT = 9/16" \varnothing X 1 3/8" OD
22	NC01-50-1086	6	BOLT METR. GR. 10.9 NC 14MM X 2THREAD X 45 MM
23	NC13-80-0273	8	BLACK CAP 1" DIA
24	91-50-0030	2	SUBFRAME PIVOT
25	01-01-2485	8	FLAT WASHER 14 GA X 13/16"OD X 25/64" ID
26	NC02-32-0012	8	LOCK WASHER ZINC 3/8"
27	NC01-37-0114	8	BOLT GR8 3/8" X 1"
28	NC01-69-0785	7	STRAIGHT GREASE FITTING 1/4-28
29	91-13-2800	1	CENTER PIVOT SHAFT
30	91-01-0020	1	HYDRAULIC HOSE PROTECTOR
31	NC02-32-0011	1	LOCK WASHER ZINC 5/16"
32	NC01-17-0058	1	HEX. BOLT GR2 ZINC 5/16-18 X 3/4"
33	91-20-0210	4	CYLINDER PIVOT
34	91-22-2200	4	FLAT WASHER HYDRAULIC CYLINDER
35	NC01-69-0159	4	COTTER PIN ZINC 3/16 X 1 1/2"
36	92-01-0005	3	WASHER 2 1/4" DIA. X 1 9/16"
37	NC01-17-0010	1	HEX. BOLT GR2 NC ZINC 1/4-20 X 2"
38	NC01-93-0001	1	HEX. NUT NC ZINC 1/4-20

AGRIMETAL**REGROUPEMENT SUBFRAME**

CREATION : 20/12/17
REVISION : 15/02/19

ASSEMBLY : **91-57-0400**

AUTHOR : J.KABWE

Page 5 de 14

#	PART #	Qty	TITLE
1	92-57-0261	1	CENTRAL BLADE MAX PRO 6-10 INCLUDED STICKER GROUP.
2	NC01-69-0791	12	GREASE FITTING 1/8 NPT STRAIGHT
3	92-57-0500	1	HYDRAULIC CYLINDER GUARD
4	01-01-2485	8	FLAT WASHER 14 GA X 13/16"OD X 25/64" ID
5	NC02-32-0012	8	LOCK WASHER ZINC 3/8"
6	NC01-17-0112	8	HEX. BOLT GR2 ZINC 3/8-16 X 3/4"

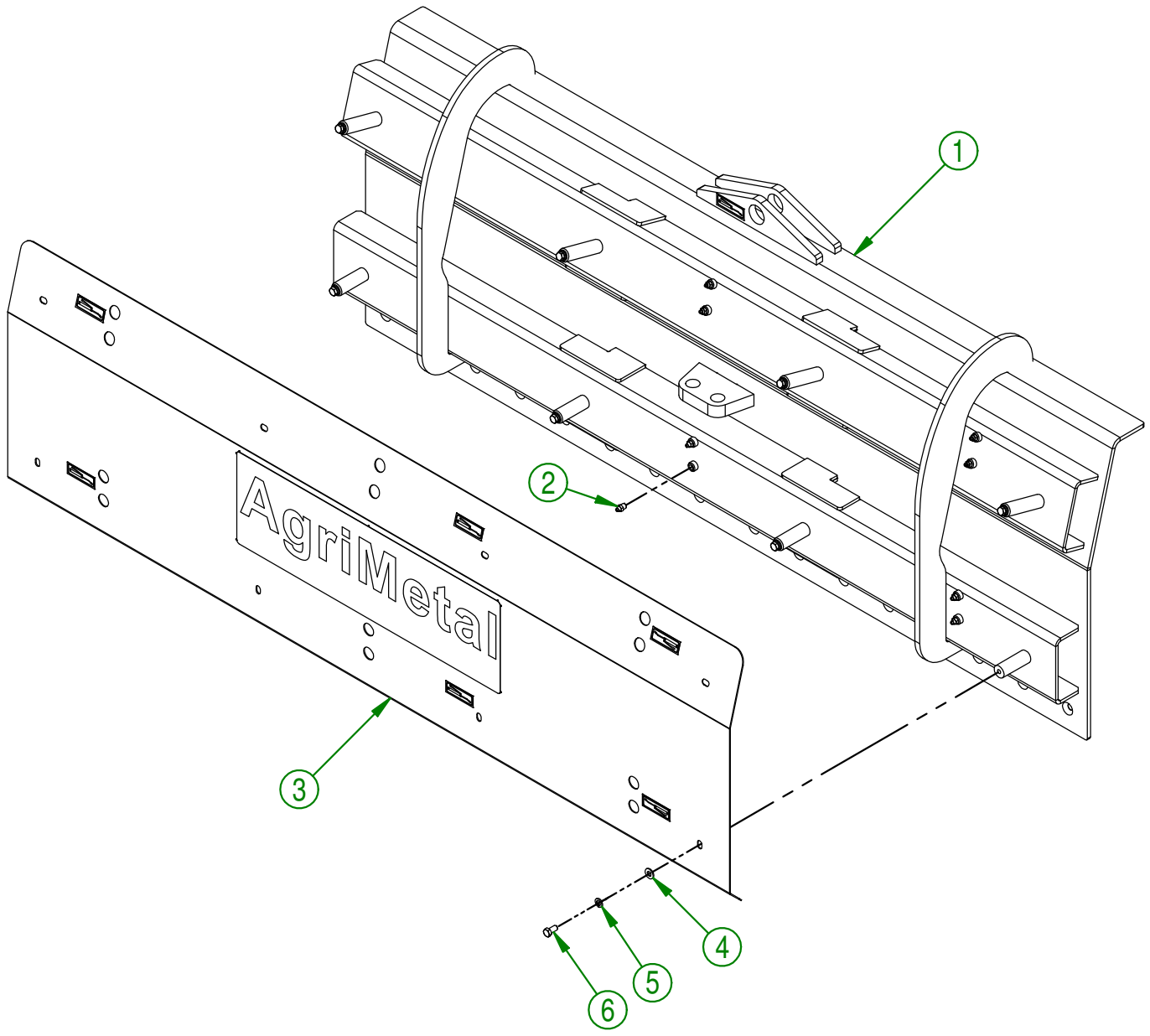

AGRIMETAL	
BLADE 6-10 GROUP	
CREATION : 22/03/18	ASSEMBLY : 92-57-0021
REVISION : 15/10/18	AUTHOR : J.KABWE Page 6 de 14

#	PART #	Qty	TITLE
1	91-42-0144	1	FLOATING SKATE (RIGHT OUTSIDE)
2	NC13-15-0325	1	FLOATING SKATE (MIDDLE FRONT)
3	NC13-15-0323	1	FLOATING SKATE (MIDDLE BACK)
4	NC13-86-0052	2	SPRING 1/2" ID X 1" OD X 5" LG
5	91-42-0142	1	FLOATING SKATE (RIGHT INSIDE)
6	NC02-48-0549	4	STAINLESS FLAT HEAD SOCKET CAP SCREW 1/2-13 X 2 1/4"
7	NC02-48-0537	7	STAINLESS FLAT HEAD SOCKET CAP SCREW 3/8-16 X 2 1/4"
8	91-20-0163	2	WASHER
9	91-20-0150	4	WASHER
10	91-20-0160	4	WASHER
11	NC01-96-0011	7	NYLON NUT 3/8-16
12	NC01-96-0014	4	NYLON INSERT LOCKNUT 1/2-13"
13	91-09-0000	4	BUSHING
14	92-57-0266	1	RIGHT BLADE

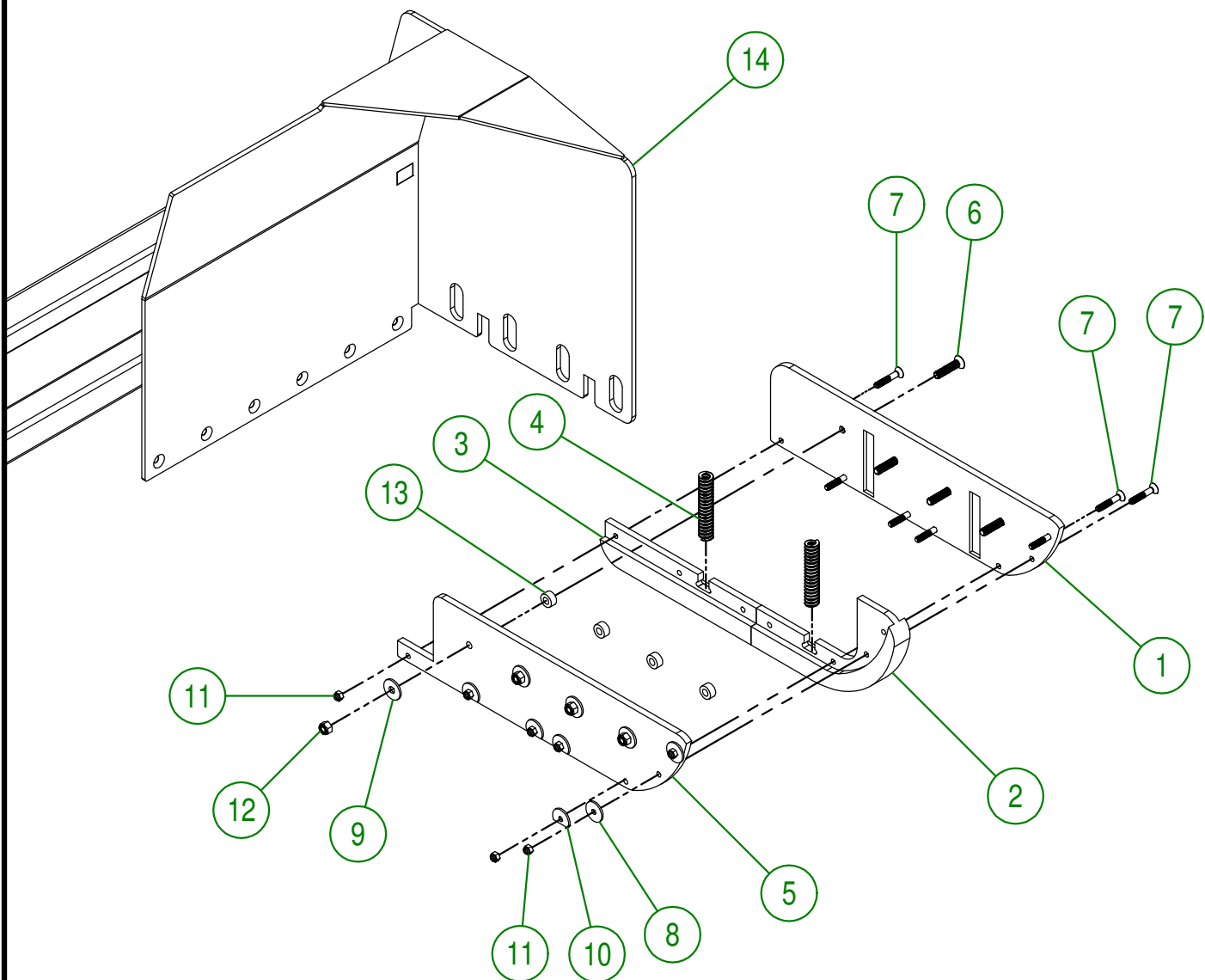

IMPORTANT

USE THIS PARTS ONLY IF YOUR SERIAL NUMBER IS INVOLVED:

#37424 OR UNDER

AGRIMETAL RIGHT BLADE GROUP

CREATION : 08/05/17
REVISION : 10/01/19

ASSEMBLY : 92-57-0046
AUTHOR : J.H. Page 7 de 14

#	PART #	Qty	TITLE
1	91-42-0400	1	FLOATING SKATE (RIGHT OUTSIDE)
2	91-42-0138	1	FLOATING SKATE (MIDDLE FRONT)
3	91-42-0150	1	FLOATING SKATE (MIDDLE BACK)
4	NC13-86-0052	2	SPRING 1/2" ID X 1" OD X 5" LG
5	NC02-48-0548	4	FLAT HEAD SOCKET CAP SCREW STAINLESS 1/2-13 X 2"
6	NC02-48-0535	7	STAINLESS FLAT HEAD SOCKET CAP SREW 3/8-16 X 1 3/4
7	91-50-0355	1	FLOATING SKATE (RIGHT INSIDE)
8	NC01-96-0011	7	NYLON NUT 3/8-16
9	NC01-96-0014	4	NYLON INSERT LOCKNUT 1/2-13"
10	91-09-0000	4	BUSHING
11	92-57-0266	1	RIGHT BLADE

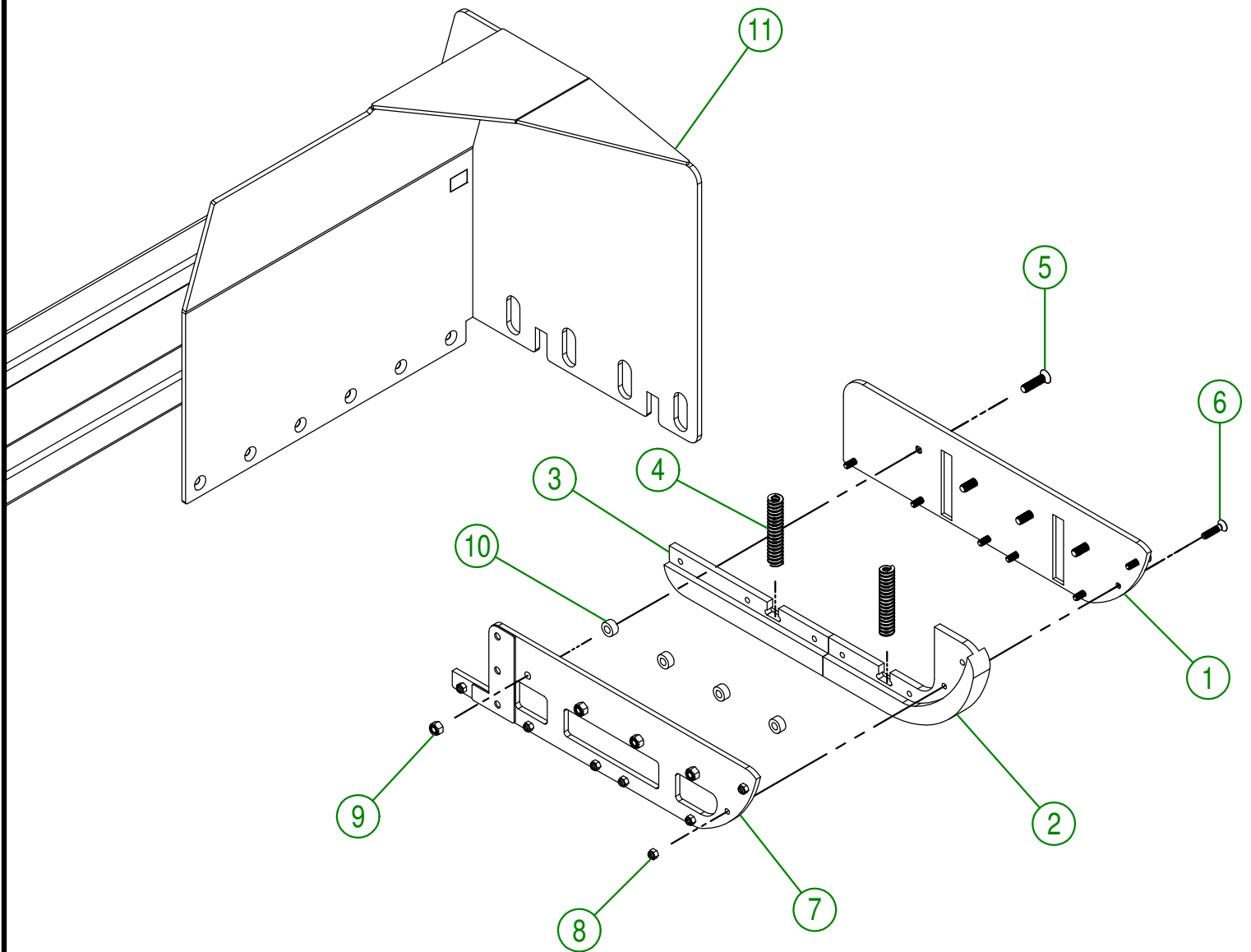

IMPORTANT

USE THIS PARTS ONLY IF YOUR SERIAL NUMBER IS INVOLVED:

#37430 OR ABOVE

AGRIMETAL
RIGHT BLADE

CREATION : 05/11/18
REVISION : 28/10/19

ASSEMBLY : **92-57-0047**

AUTHOR : J. Houle

Page 8 de 14

#	PART #	Qty	TITLE
1	91-42-0140	1	FLOATING SKATE (LEFT EXT.)
2	NC13-15-0325	1	FLOATING SKATE (MIDDLE FRONT)
3	NC13-15-0323	1	FLOATING SKATE (MIDDLE BACK)
4	NC13-86-0052	2	SPRING 1/2" ID X 1" OD X 5" LG
5	91-09-0000	4	BUSHING
6	91-42-0136	1	FLOATING SKATE (LEFT INT.)
7	NC02-48-0549	4	STAINLESS FLAT HEAD SOCKET CAP SCREW 1/2-13 X 2 1/4"
8	NC02-48-0537	7	STAINLESS FLAT HEAD SOCKET CAP SCREW 3/8-16 X 2 1/4"
9	91-20-0163	2	WASHER
10	91-20-0160	4	WASHER
11	91-20-0150	4	WASHER
12	NC01-96-0011	7	NYLON NUT 3/8-16
13	NC01-96-0014	4	NYLON INSERT LOCKNUT 1/2-13"
14	92-57-0271	1	LEFT BLADE

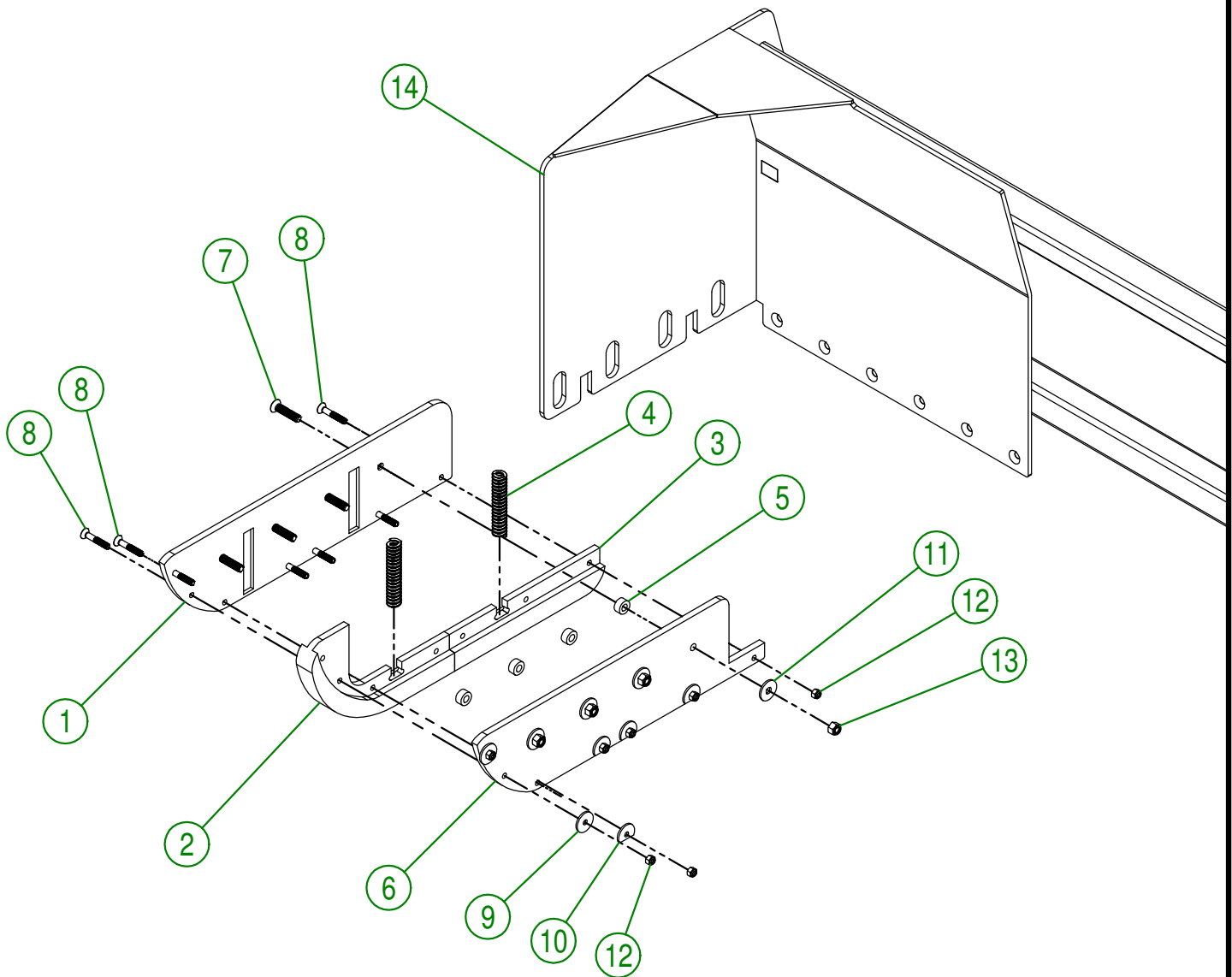

IMPORTANT

USE THIS PARTS ONLY IF YOUR SERIAL NUMBER IS INVOLVED:

#37424 OR UNDER

AGRIMETAL LEFT BLADE GROUP.

CREATION : 08/05/17
REVISION : 10/01/19

ASSEMBLY : 92-57-0051
AUTHOR : J.H. Page 9 de 14

#	PART #	Qty	TITLE
1	91-42-0403	1	FLOATING SKATE (LEFT EXT.)
2	91-42-0138	1	FLOATING SKATE (MIDDLE FRONT)
3	91-42-0150	1	FLOATING SKATE (MIDDLE BACK)
4	NC13-86-0052	2	SPRING 1/2" ID X 1" OD X 5" LG
5	91-09-0000	4	BUSHING
6	91-50-0360	1	FLOATING SKATE (LEFT INSIDE)
7	NC02-48-0548	4	FLAT HEAD SOCKET CAP SCREW STAINLESS 1/2-13 X 2"
8	NC02-48-0535	7	STAINLESS FLAT HEAD SOCKET CAP SREW 3/8-16 X 1 3/4
9	NC01-96-0011	7	NYLON NUT 3/8-16
10	NC01-96-0014	4	NYLON INSERT LOCKNUT 1/2-13"
11	92-57-0271	1	LEFT BLADE

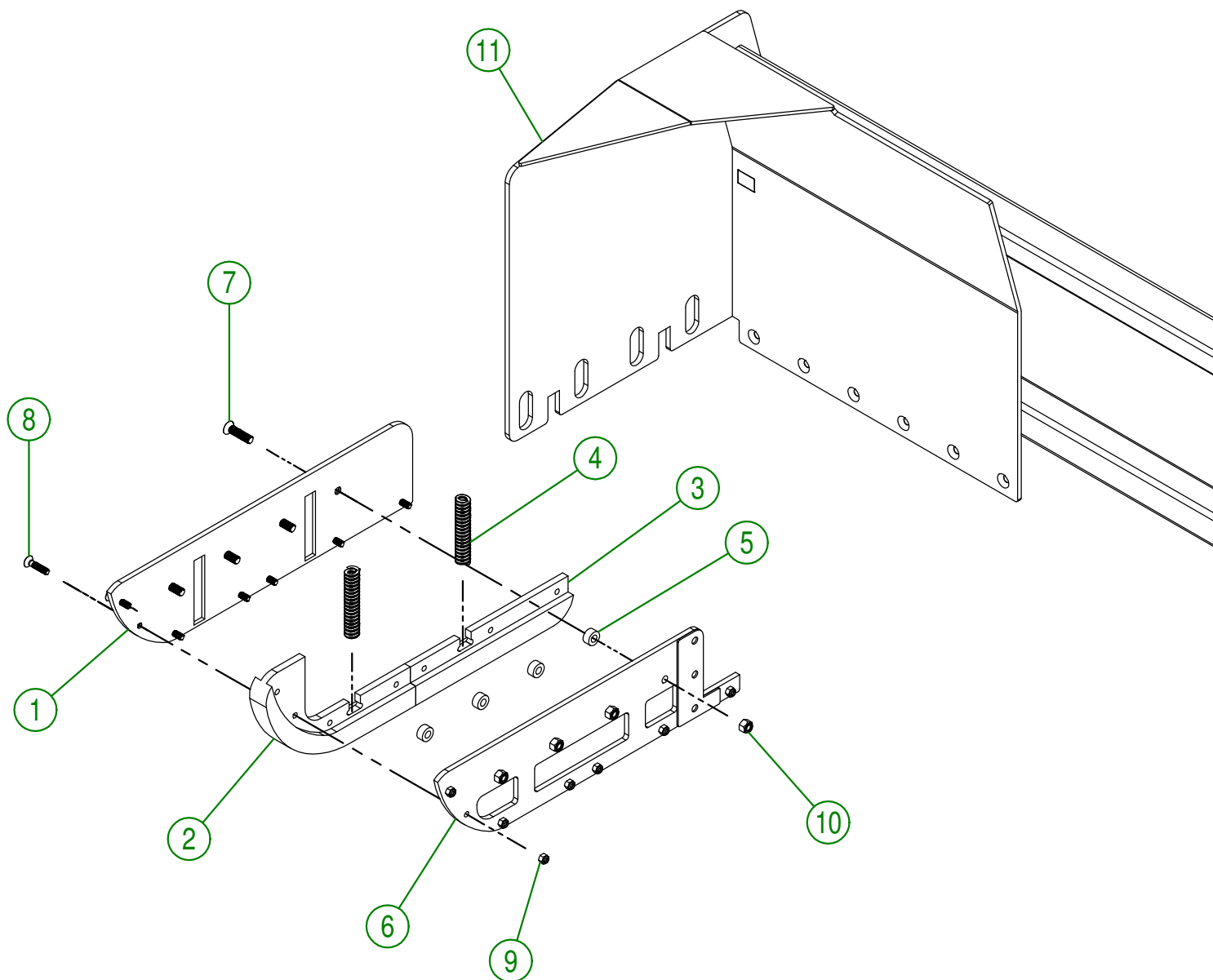

IMPORTANT

USE THIS PARTS ONLY IF YOUR SERIAL NUMBER IS INVOLVED:

#37430 OR ABOVE

AGRIMETAL
LEFT BLADE GROUP.

CREATION : 05/11/18
REVISION : 28/10/19

ASSEMBLY : **92-57-0052**

AUTHOR : J. Houle Page 10 de 14

#	PART #	Qty	TITLE
1	91-50-0245	1	LEFT MUD GUARD BRACKET
2	NC01-13-0062	12	ELEVATOR STAINLESS BOLT 5/16-18 X 1"
3	NC02-22-0008	12	WASHER ZINC 5/16"
4	NC02-32-0011	12	LOCK WASHER ZINC 5/16"
5	NC02-07-0017	12	HEX. NUT 5/16-18
6	91-42-0190	1	MUD GUARD (LEFT)
7	91-50-0250	1	RIGHT MUD GUARD BRACKET
8	91-42-0195	1	MUD GAURD (RIGHT)
9	NC01-54-0200	6	CARR. BOLT STAINLESS 1/2-13 X 2"
10	NC02-32-0100	6	LOCK WASHER STAINLESS 1/2"
11	NC02-14-0100	6	HEX NUT STAINLESS 1/2-13

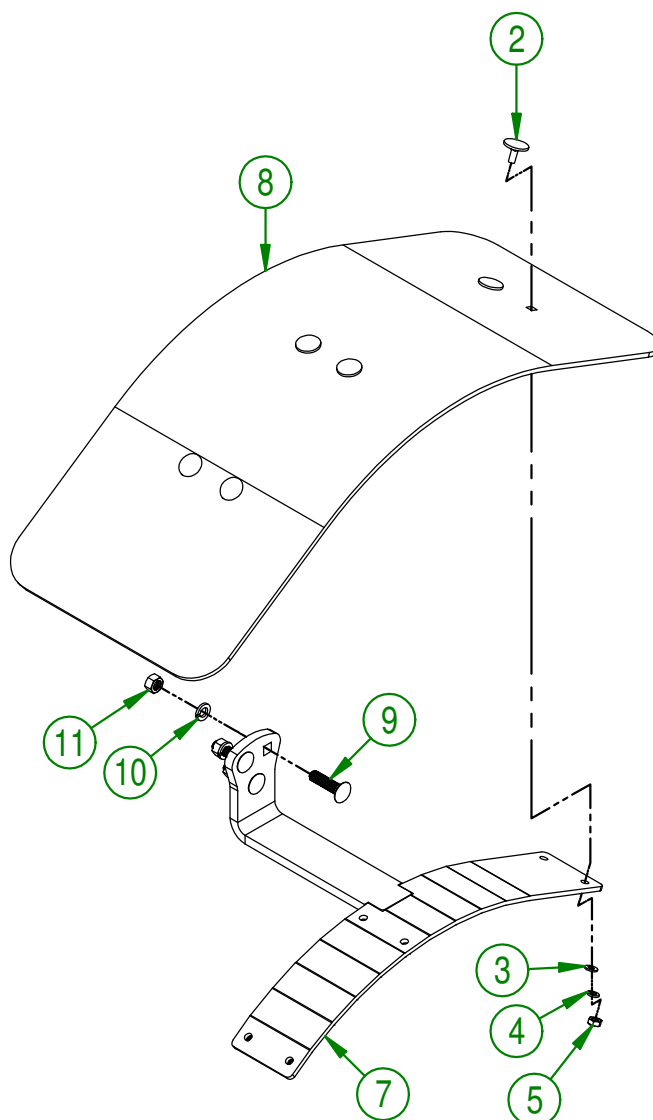
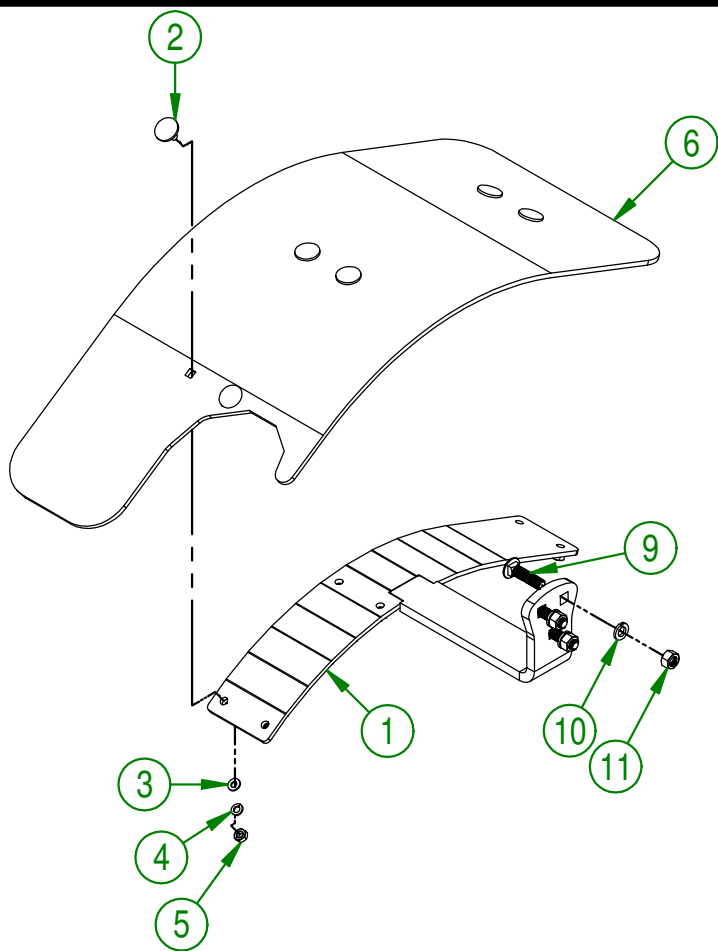

AGRIMETAL	
FENDEUR KIT (UHMW)	
CREATION : 20/12/17	ASSEMBLY : 91-57-0405
REVISION : 04/01/18	AUTHOR : J.KABWE Page 11 de 14

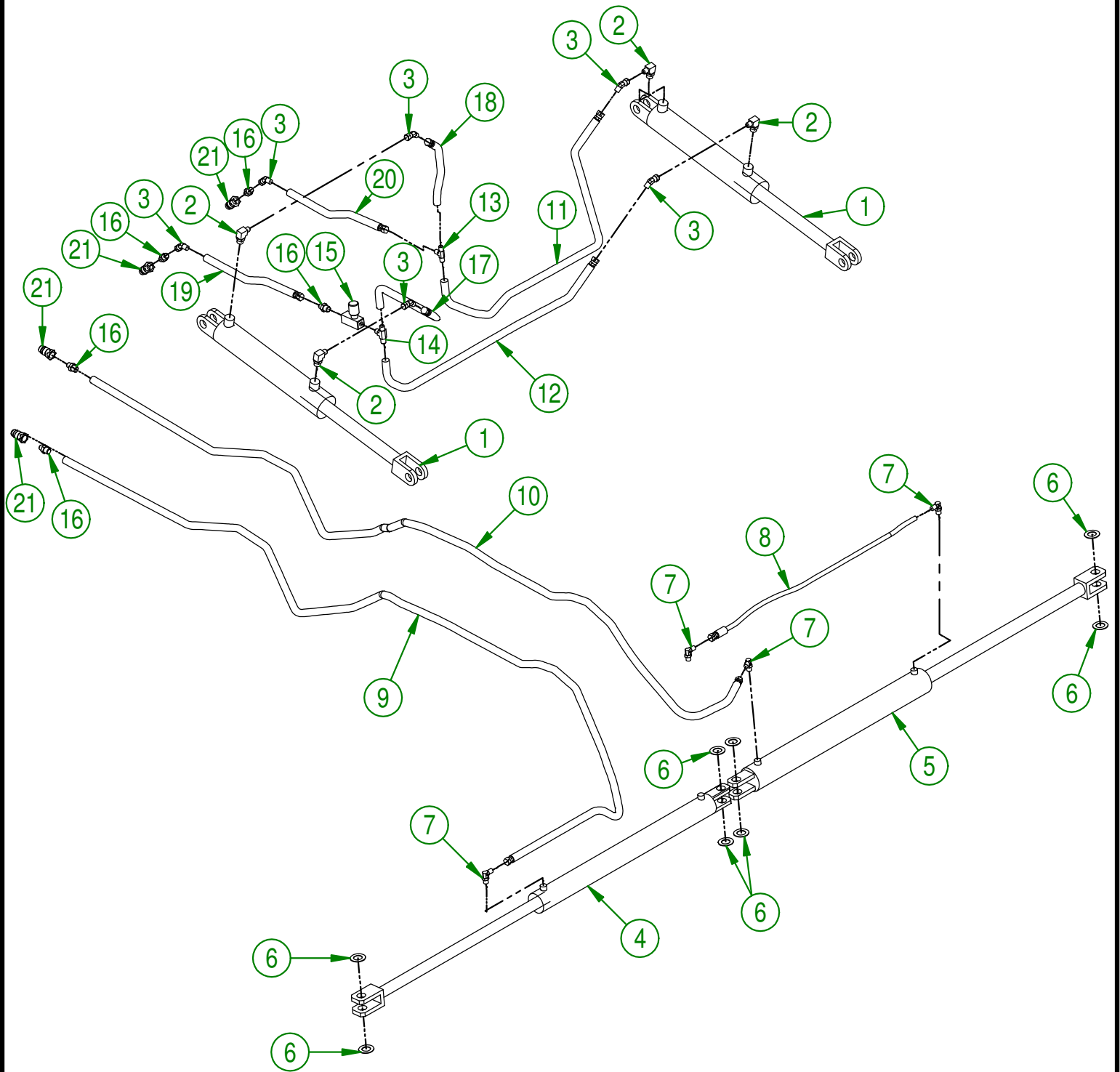

AGRIMETAL	
HYDRAULIC GROUP.	
CREATION : 21/12/17	ASSEMBLY : 91-57-0420
REVISION : 15/02/19	AUTHOR : J.KABWE Page 12 de 14

#	PART #	Qty	TITLE
1	NC13-45-0257	2	HYDRAULIC CYLINDER 2 1/2" X 12" STROKE
2	NC13-45-0242	4	90 DEG ELBOW
3	NC13-45-0270	6	45 DEG ELBOW
4	NC13-45-0238	1	HYDRAULIC CYLINDER 2" X 24" STROKE
5	NC13-45-0237	1	HYDRAULIC CYLINDER 2 1/2" X 24" STROKE
6	91-22-2200	8	FLAT WASHER HYDRAULIC CYLINDER
7	NC13-45-0254	4	90 DEG ELBOW 9/16"-18 MALE SAE6 O RING X 3/8" MALE JIC
8	NC17-02-0351	1	HYDRAULIC HOSE 34"
9	NC17-02-0384	1	HYDRAULIC HOSE 106 3/8"
10	NC17-02-0384	1	HYDRAULIC HOSE 106 3/8"
11	NC17-02-0354	1	HYDRAULIC HOSE 60"
12	NC17-02-0354	1	HYDRAULIC HOSE 60"
13	NC13-45-0289	1	T 3/8 MALE JIC X 3/8 MALE JIC X 3/8 MALE JIC
14	NC13-45-0244	1	TEE FITTING 3/8" MALE JIC X 3/8" MALE JIC X 3/8" MAL JIC
15	NC13-45-0241	1	FLOW CONTROLE 3/8" NPT FEMALE
16	NC13-45-0288	5	STRAIGHT FITTING 1/2" MALE JIC X 3/8" MALE NPT
17	NC17-02-0381	1	HYDRAULIC HOSE 21 1/4"
18	NC17-02-0381	1	HYDRAULIC HOSE 21 1/4"
19	NC17-02-0350	1	HYDR. HOSE 3/8" X 26" LG 3/8 JIC 37 FEM.X 3/8 JIC 37 FEM.
20	NC17-02-0381	1	HYDRAULIC HOSE 21 1/4"
21	NC13-45-0285	4	QUICK COUPLER 3/8 NPTF

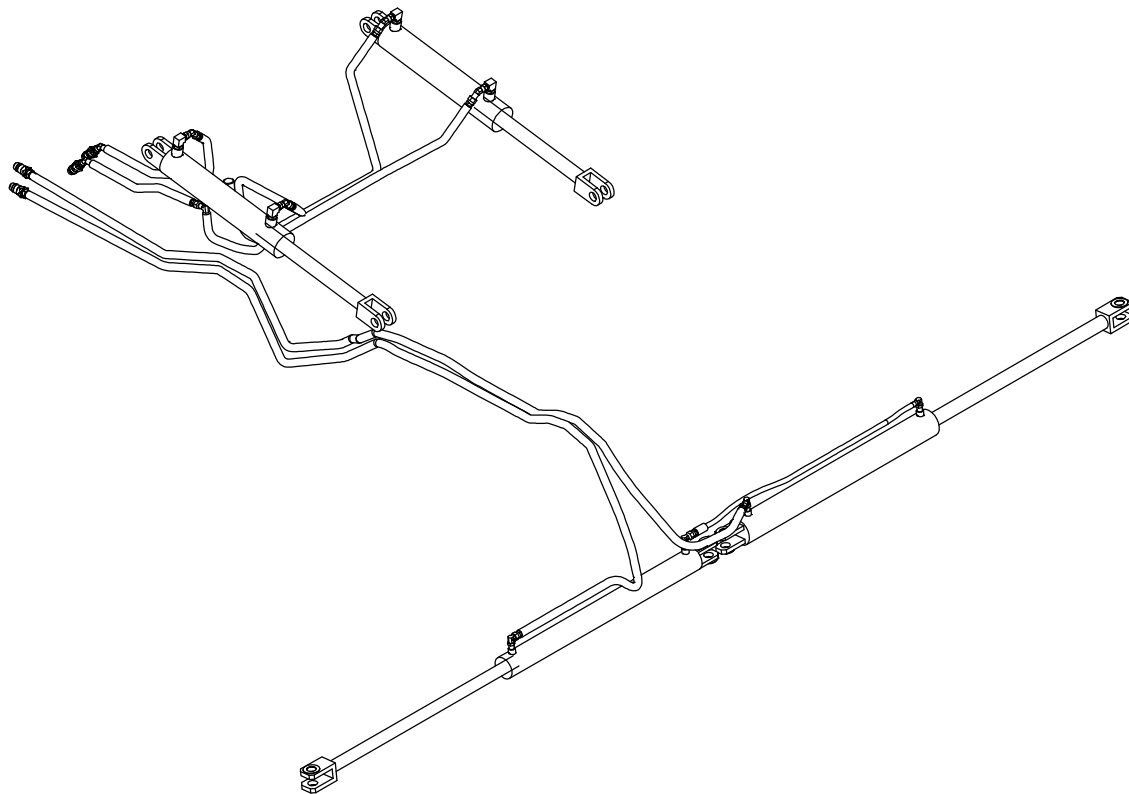

AGRIMETAL	
HYDRAULIC GROUP.	
CREATION : 21/12/17	ASSEMBLY : 91-57-0420
REVISION : 15/02/19	AUTHOR : J.KABWE Page 13 de 14

#	PART #	Qty	TITLE
1	NCI3-33-0024	14	STICKER GREASE HERE
2	NCI3-33-0183	2	STICKER CAUTION OPERATION MANUAL
3	NCI3-33-0319	3	STICKER IMPORTANT GREASE EVERY 5 HOURS
4	NCI3-33-0268	2	STICKER WARNING
5	NCI3-33-0265	2	STICKER MAX PRO
6	28-60-0050	2	STICKER SCOTCHLITE
7	NCI3-33-0318	1	STICKER AGRIMETAL INC (XL)

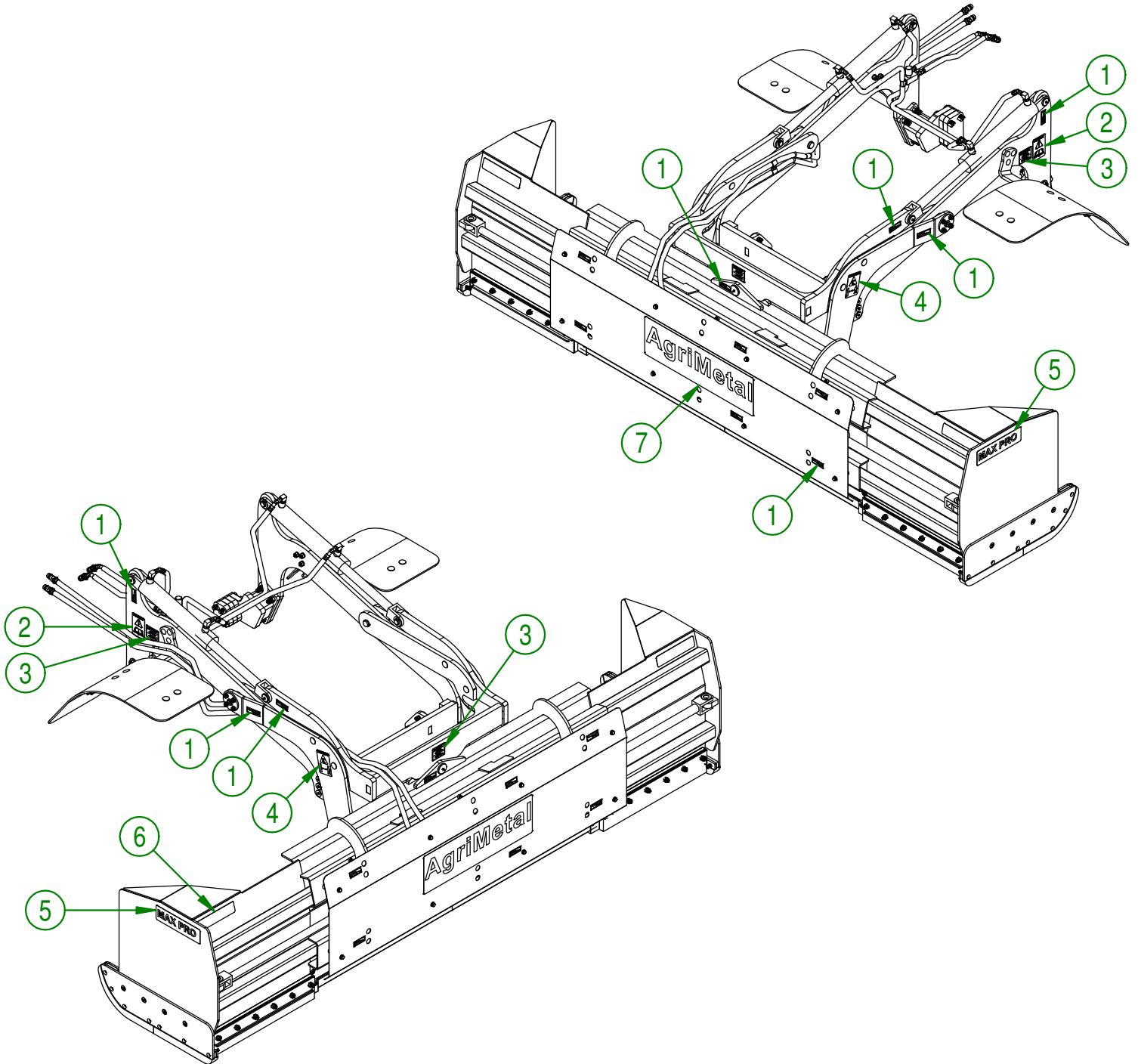

AGRIMETAL	
MAX PRO 7-12 B (MAHINDRA 2555)	
CREATION : 21/12/17	ASSEMBLY : 91-99-2501
REVISION : 15/02/19	AUTHOR : J.KABWE Page 14 de 14