

PTO MODEL
TUFF VAC 5000

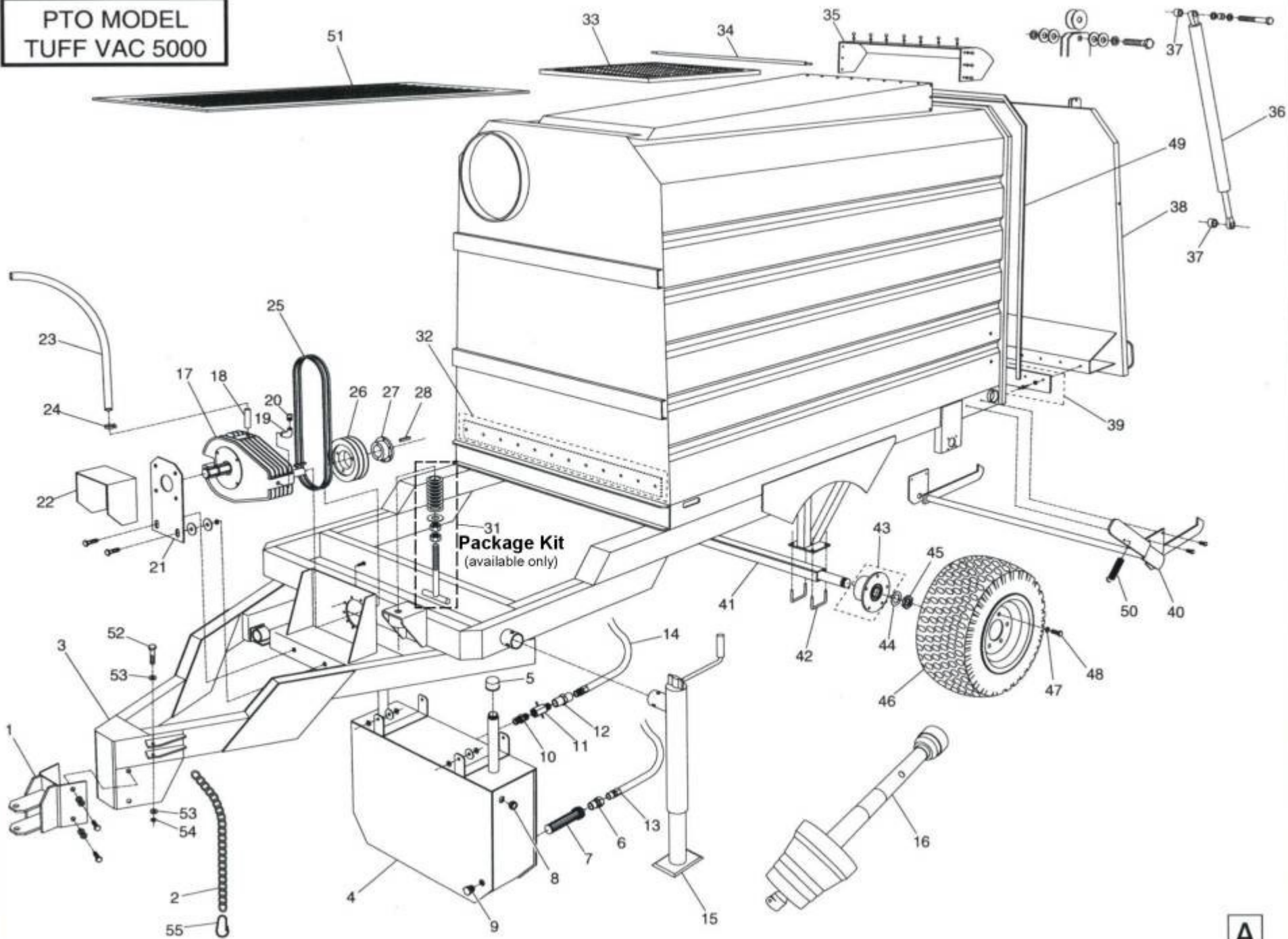

31
Package Kit
(available only)

A

TUFF VAC 5000 PTO

REF.	PART NO.	DESCRIPTION	QTE
1	16-50-0105	HITCH	1
2	16-41-0040	SAFETY CHAIN 10MM GRADE 70 X 58" LONG	2
3	16-55-0300	BODY MOD:PTO "STICKER INCLUDED"	1
4	16-50-0115	HYDRAULIC OIL RESERVOIR "STICKER INCLUDED"	1
5	NC13-45-0016	FILLING CAP	2
6	NC13-45-0066	HEXAGONAL REDUCER 3/4 NPT FEM..X 1 NPT MALE	1
7	NC13-45-0050	STRAINER TANK	1
8	NC01-76-0001	SIGHT GLASS 3/4 NPT	1
9	NC13-45-0015	HEXAGONAL CAP 1/2 NPTF MALE	1
10	NC13-45-0029	MALE PIPE COUPLING 1/2" NPT	1
11	NC13-65-0023	BEFORE -04/98 #17733- BALL VALVE 1/2 NPT FEMALE	1
N/I	NC13-45-0020	AFTER -04/98 #17733- CHECK VALVE 1/2" NPT	1
12	NC13-45-0095	AFTER -04/98 #17733- FEMALE PIPE COUPLING 1/2 NPT	1
13	16-55-0120	HYDR.HOSE 3/4-H ASSY.3/4-14 MALE RIG.X 3/4-14 MALE RIG. X 40" LG	1
14	16-55-0125	HYDR.HOSE 1/2-H ASSY 1/2-14 MALE RIG.X 1/2-14 MALE SWI. X 48" LG	2
15	16-55-0249	JACK	1
16	16-34-0030	PTO SHAFT T40 X 44" LG	1
17	16-34-0101	TRANSMISSION A624 RATIO 1:6.9	1
18	NC13-65-0010	GALV.NIPPLE 3/8 NPT X 1 1/2" LG	1
19	NC13-65-0003	BRASS ELBOW 90° 3/8 FEM. NPT X 3/8 MALE NPT	1
20	NC02-44-0204	ALLEN SET SCREW 3/8"-18 NPT	1
21	16-55-0305	SUPPORT TRANSMISSION "STICKER INCLUDED"	1
22	01-55-0535	PTO SHAFT GUARD "STICKER INCLUDED"	1
23	16-46-0525	OVER FLOW TRANSMISSION HOSE 39" LG	1
24	NC01-65-0055	COLLAR (HS8)	1
25	NC14-25-0560	V-BELT B-46	2
26	NC14-62-0089	CAST IRON SHAVE PULLEY 2B5.6 SDS	2
27	16-39-0435	TAPERED QD BUSHING SDS X Ø 1 1/4" KW 5/16"	1
28	16-41-0905	SQUARE KEY 5/16" X 5/16" X 1 7/8" LG	1
31	16-55-0255	-03/05 #25982- BELT TENSION KIT ASSY.	1
32	16-55-0186	RUBBER PAD ASSY. "FLAT WASHER AND POT RIVET INCLUDED"	1
N/I	16-55-0177	RUBBER PAD SMALL COMPL."FLAT WASHER AND POT RIVET INCLUDED"	1
33	16-55-0060	OPT.HARD SURFACE FILTER ASSY.	4
34	16-55-0056	OPT.FILTER SUPPORT ASSY.	4
35	16-50-0165	DEFLECTOR "EXTENSION"	1
36	NC13-80-0005	GAS CYLINDER	2
37	01-09-0000	ROLLER BEARING BUSHING	4
38	16-55-0266	BACK DOOR "STICKER INCLUDED"	1
39	16-55-0185	DOOR RUBBER PAD ASSY. "FLAT WASHER AND POT RIVET"	1
40	16-50-0150	DOOR LATCH	1
41	16-50-0060	AXLE	1
42	16-13-0600	AXLE COLLAR	4
43	16-55-0055	HUB ASSY.	2
N/I	16-50-0100	HUB	2
N/I	NC14-75-0071	BALL BEARING 6207-2RS	4
44	16-09-1005	FLAT WASHER 2" Dia. X Ø 1 3/8" X .125" LG	2
45	NC01-98-0021	NYLON INSERT LOCKNUTS 1 1/4"-18	2
46	16-55-0050	WHEEL 23" ASSY.	2
N/I	NC14-70-0001	TIRE 23-10.5 X 4 PLIS TBL	2
N/I	16-55-0051	RIM 12" Dia.	2
N/I	NC14-70-0003	VALVE TBL TR-13	2
47	NC02-32-0014	LOCK WASHER Ø 1/2"	10
48	NC01-29-0248	HEX.BOLT 1/2"-20 X 1 1/4" LG (GRADE 5)	10
49	16-42-0220	FOAM STICKER 148" LG	1
50	NC13-85-0008	SPRING 7/8" Dia. X 5" LG	1
51	16-03-4800	EXHAUST SCREEN	1

TUFF VAC 5000 PTO

REF.	PART NO.	DESCRIPTION	QTE
52	NC01-29-0253	HEX.BOLT 1/2"-20 X 2 1/2" LG (GRADE 5)	2
53	NC02-25-0011	FLAT WASHER Ø 17/32"	2
54	NC01-97-0008	NYLON INSERT LOCKNUTS 1/2"-20	2
55	NC01-75-0007	RAPID LINKS 1/2"	2

PTO MODEL
TUFF VAC 5000

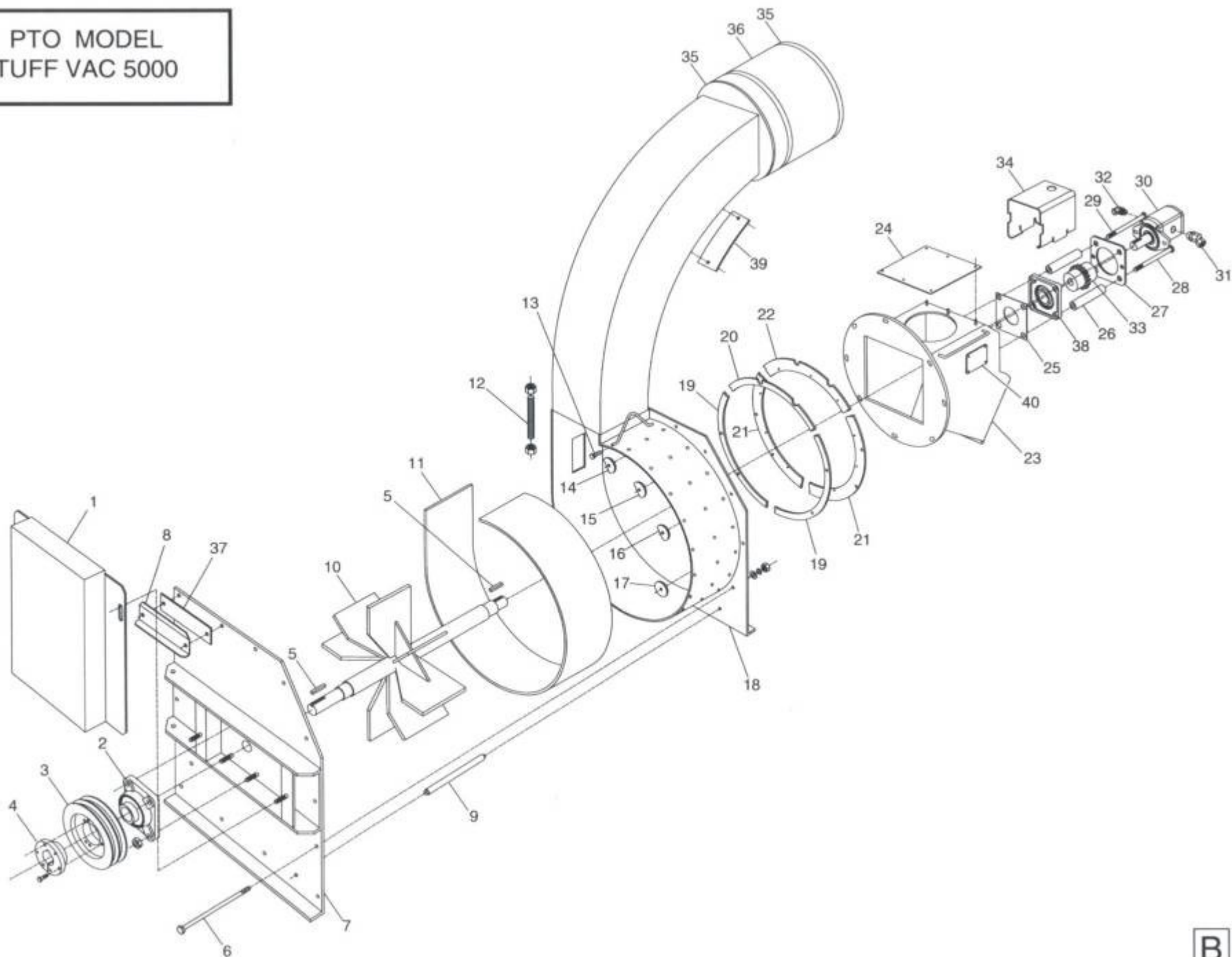

TUFF VAC 5000 PTO

REF.	PART NO.	DESCRIPTION	QTE
1	16-55-0222	BELT GUARD "STICKER INCLUDED"	1
2	12-38-0001	FLANGE BEARING 4 Ø UCF 207-20 X Ø 1 1/4" (GREASE FITTING 1/4"-28)	3
3	NC14-62-0089	CAST IRON SHAVE PULLEY 2B5.6 SDS	2
4	NC14-62-0011	TAPERED QD BUSHING SDS 1 1/4" KW 1/4"	1
5	01-41-0910	SQUARE KEY 1/4" X 1/4" X 1 1/2" LG	7
6	NC01-17-0146	HEX. BOLT 3/8"-16 X 9" LONG (GRADE 2)	14
7	16-50-0160	BLOWER CASING COVER "STICKER INCLUDED"	1
8	16-01-2295	EJECTION CHUTE PROTECTOR	1
9	16-13-0805	BLOWER CASING SPACER 5/8" Dia.X 8 1/4" LG	2
10	16-50-0046	IMPELLER	1
11	16-50-0110	WEAR LINER	1
12	16-31-0250	LINER ADJUSTMENT ROD 5/8"-11 X 5 3/4" LG	1
13	16-30-9955	SUCTION BOX FLANGE STOPPER 3/8"-16 X 1 1/4" LG	1
14	16-13-2815	BOLT HEAD PROTECTOR 2" Dia. X 3/8" LG	1
15	16-13-2810	BOLT HEAD PROTECTOR 2" Dia. X 3/8" LG	1
16	16-13-2805	BOLT HEAD PROTECTOR 2" Dia. X 3/8" LG	1
17	16-13-2820	BOLT HEAD PROTECTOR 2" Dia. X 3/8" LG	5
18	16-50-0180	BLOWER CASING "STICKER INCLUDED"	1
19	16-04-0300	FLANGE SHIM	2
20	16-04-0295	SUCTION BOX FLANGE SHIM	1
21	16-04-6810	SUCTION BOX FLANGE STOPPER	2
22	16-04-6805	SUCTION BOX FLANGE STOPPER	1
23	16-50-0175	SUCTION BOX "STICKER INCLUDED"	1
24	16-55-0220	SUCTION BOX COVER "STICKER INCLUDED"	1
25	16-01-3145	BEARING SHIM	1
26	16-09-0800	BUSHING 1" X 1/2" X 4 3/4" LG	4
27	16-04-6855	HYDRAULIC PUMP SUPPORT	1
28	NC01-17-0269	HEX.BOLT 1/2"-13 X 6 1/2" LG (GRADE 2)	2
29	16-30-9965	BOLT 1/2"-13 X 6 1/2" LG (GRADE 2) SPECIAL	2
30	NC14-45-0010	HYDR.PUMP.	1
31	NC13-45-0044	45° 1 1/16"-12 MALE O RING X 3/4 NPT FEM. TOUR.	1
32	NC13-45-0046	45° 7/8-14 MALE O RING X 1/2 NPT FEM. TOUR.	1
33	16-55-0187	CHAIN COUPLING 4016 ASSY. Ø 1" X Ø 3/4"	1
N/I	NC14-55-0154	COUPLING 4016 X Ø 1" KW 1/4" 2SS 5/16"-18	1
N/I	NC14-55-0169	COUPLING 4016 X Ø 3/4" KW 3/16" 2SS 5/16"-18	1
N/I	NC14-20-0030	DOUBLE CHAIN #4016	1
N/I	NC02-44-0103	ALLENS SET SCREW 5/16"-18 X 3/8" LG	4
34	16-55-0216	CHAIN COUPLING GUARD "STICKER INCLUDED"	1
35	NC01-65-0082	COLLAR (HAS224)	2
36	16-42-0065	HOSE CHUTE 13" Dia.	1
37	16-42-0225	FOAM STICKER 8" LG	1
38	16-38-0000	FLANGE BEARING SPECIAL 4 Ø UCF 207-20 X Ø 1 1/4"	1
39	16-55-0310	ACCESS DOOR "STICKER INCLUDED"	1
40	22-55-0250	ACCESS DOOR "STICKER INCLUDED"	2

CONVEYOR
TUFF VAC 5000

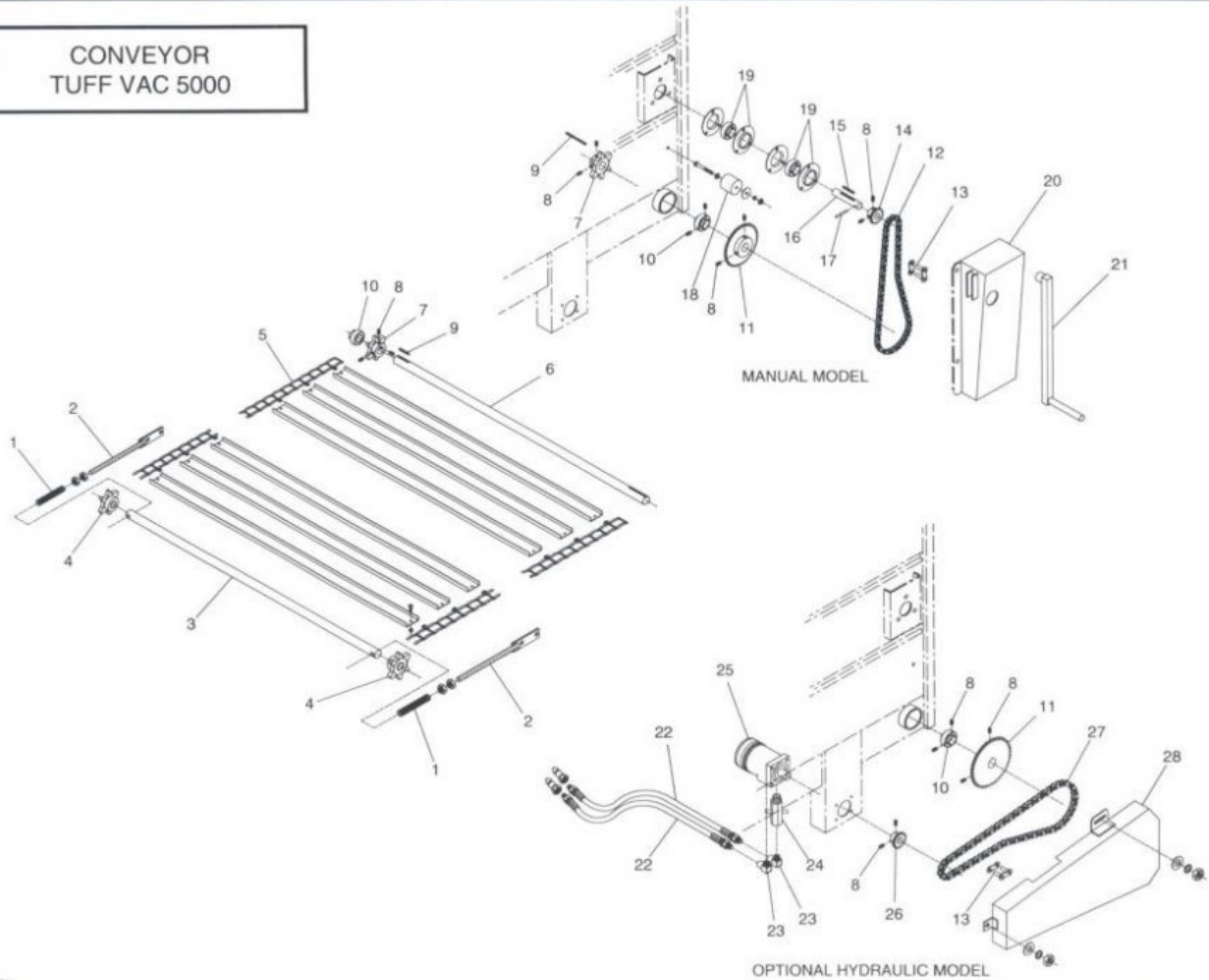

TUFF VAC 5000 PTO

REF.	PART NO.	DESCRIPTION	QTE
1	NC13-86-0050	BLUE SPRING 1" Dia. X 4" LG	2
2	04-50-3035	CONVEYOR CHAIN TIGHTNER	2
3	16-13-1205	CONVEYOR IDLER SHAFT 7/8" Dia. X 48" LG	1
4	04-55-0020	CAST IRON SPROCKET 62B6 COMPL." BRASS BUSHING INCLUDED "	2
N/I	NC14-56-0003	CAST IRON SPROCKET 62B6 X Ø 1 1/8" NO KW - NO SS	2
N/I	NC13-80-0053	OILITE BUSHING 1 1/8" X Ø 7/8" X 1 1/2" LG	2
5	16-55-0040	CHAIN #62 AND U PADDLE ASSY.	1
N/I	16-37-0190	CHAIN #62 111 LINKS .RIGHT SIDE / 111 LINKS .LEFT SIDE " FLOOR "	1
N/I	04-37-0205	CHAIN (BOTH SIDE) #62 / FT	1
N/I	NC14-20-0035	LINK #62	2
N/I	NC14-20-0003	COUPLING LINK #62	2
N/I	NC14-20-0004	RIGHT ATTACHMENT LINK #62	1
N/I	NC14-20-0005	LEFT ATTACHMENT LINK #62	1
N/I	16-01-1600	U PADDLE 41 7/8" LG	22
N/I	NC01-37-0004	HEX.BOLT 1/4"-28 X 3/4" LG (GRADE 8)	44
N/I	NC01-97-0004	NYLON INSERT LOCKNUTS 1/4"-28	44
6	16-13-1405	DRIVE SHAFT 1" Dia. X 49 3/4" LG	1
7	NC14-56-0002	CAST IRON SPROCKET 62B6 X Ø 1" KW 1/4"	2
8	NC02-44-0103	ALLENS SET SCREW 5/16"-18 X 3/8" LG	16
9	01-41-0910	SQUARE KEY 1/4" X 1/4" X 1 1/2" LG	3
10	16-38-0135	BALL BEARING UC 205-16 X Ø 1"	2
11	NC14-55-0041	SPROCKET 40B36 X Ø 1" KW 1/4"	1
12	04-37-1174	CHAIN #40 X 37 3/4" LG	1
13	NC14-20-0025	CONNECTING LINK #40	2
14	NC14-55-0021	SPROCKET 40B13 X Ø 7/8" KW 1/4" 2SS 5/16"-18	1
15	16-41-0900	SQUARE KEY 1/4" X 1/4" X 1" LG	1
16	16-13-1200	CONVEYOR REDUCTION SHAFT 7/8" Dia. X 4 1/2" LG	1
17	NC01-69-0463	SPRING PIN 1/4" X 1 3/4" LG	5
18	06-42-0120	NYLON TIGHTENER 2" Dia. X Ø 25/64" X 2" LG	1
19	16-55-0272	PRESS.STEEL FLANGE BEARING Ø 7/8" ASSY.	2
N/I	NC14-75-0009	PRESSED STEEL FLANGE (MS52)	4
N/I	NC14-75-0015	BALL BEARING SB 205-14 X Ø 7/8"	2
N/I	NC02-32-0011	LOCK WASHER Ø 5/16"	3
N/I	NC02-07-0017	HEX.NUT 5/16"-18	3
20	16-55-0202	MANUAL CONVEYOR CHAIN GUARD "STICKER INCLUDED"	1
21	16-50-0080	CRANK HANDLE	1
22	16-55-0089	HYDR.HOSE 3/8" Dia. COMPL. HYDR.CONVEYOR OPTION	2
N/I	16-55-0090	HYDR.HOSE 3/8"-H ASS 1/2"-14 MALE RIG. X 1/2"-14 MALE SWI.X 195" LG	2
N/I	NC13-45-0014	QUICK DISCON.COUPLER 1/2"-14 NPTF	2
23	NC13-45-0025	90° FEMALE 1/2 NPT X MALE 1/2 NPT	2
24	NC13-45-0020	CHECK VALVE 1/2" NPT	1
25	NC14-45-0004	HYDRAULIC MOTOR	1
26	NC14-55-0027	SPROCKET 40B15 X Ø 1" KW 1/4"	1
27	16-37-1000	CHAIN #40 X 45" LG	1
28	16-55-0239	HYDR.CONVEYOR CHAIN GUARD "STICKER INCLUDED"	1

HAND PICK-UP HOSE
TUFF VAC 5000
(OPTION)

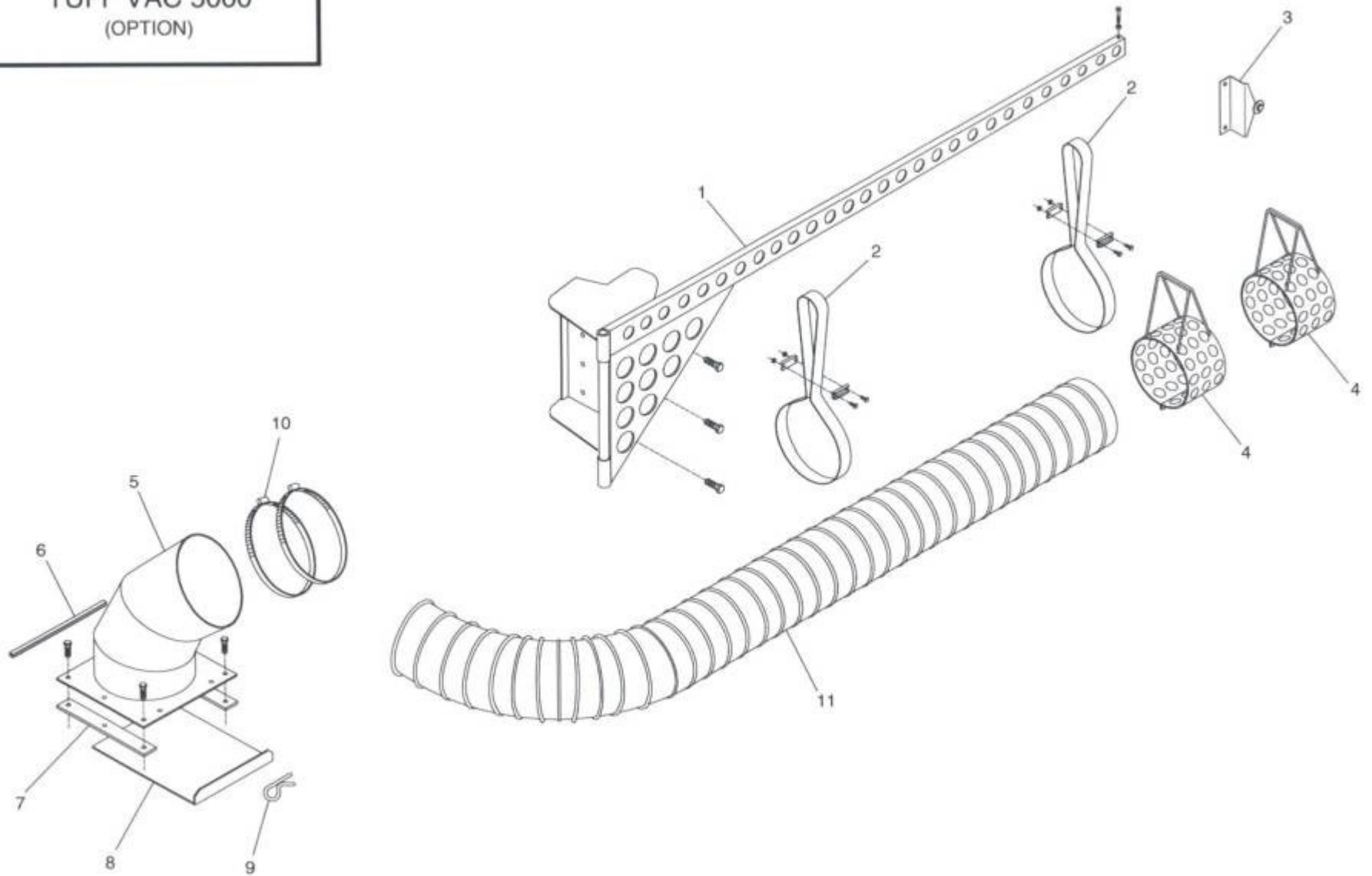

TUFF VAC 5000 PTO

REF.	PART NO.	DESCRIPTION	QTE
1	16-50-0120	FLEXIBLE HOSE SUPPORT	1
2	16-55-0180	HOSE STRAP ASSY.	2
N/I	16-41-4000	YELLOW STRAP ONLY	2
N/I	16-01-2650	STRAP SECURING	4
N/I	NC01-29-0003	HEX.BOLT.1/4"-28 X 5/8" LG (GRADE 5)	4
N/I	NC01-97-0004	NYLON INSERT LOCKNUTS 1/4"-28	4
3	16-01-2165	HOSE SUPPORT	1
4	16-55-0181	HOSE HANDLE ASSY.	2
5	16-55-0274	ELBOW 8" Dia.	1
6	16-42-0200	FOAM STICKER 8 1/2" LG	1
7	16-21-0200	ALUMINIUM SHIM 9 1/2" LG	2
8	16-01-2501	ELBOW TRAP	1
9	NC01-63-0026	HITCH PIN CLIPS 5/32" X 3" LG	1
10	NC01-65-0077	COLLAR (HS128)	2
11	16-46-0455	FLEXIBLE HOSE 8" Dia. X 192" LG	1

2-WAY SPLITTER
VALVE OPTION
TUFF VAC 5000

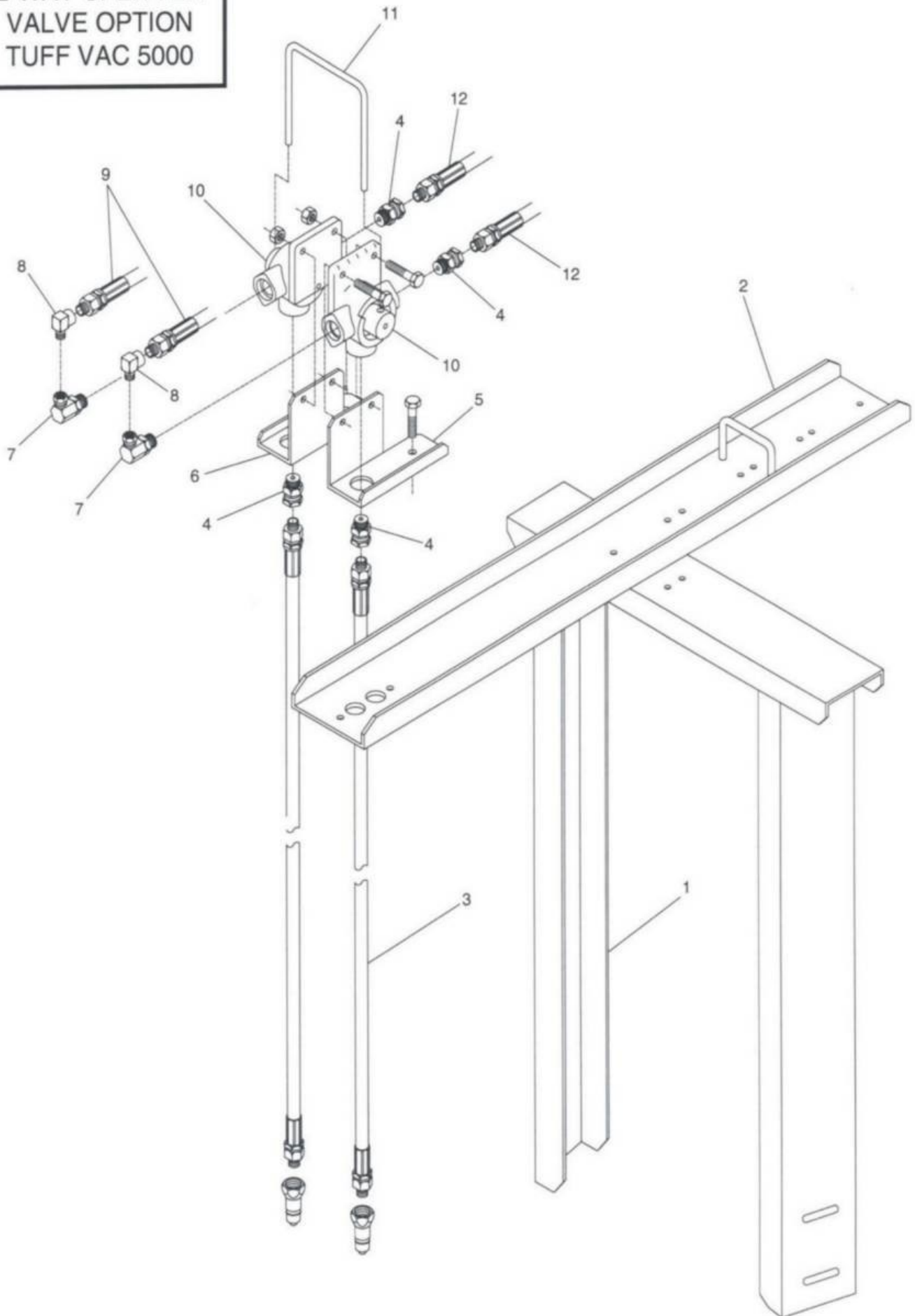

TUFF VAC 5000 PTO

REF.	PART NO.	DESCRIPTION	QTE
1	16-50-2075	HYDRAULIC VALVE SUPPORT	1
2	16-50-2101	HYDR.VALVE SUPPORT ADJUSTABLE	1
3	16-55-0271	BEFORE -06/95 #0000-HYDR.HOSE 3/8" Dia. ASSY."3 WAY SPLITER VALVE 1/2 NPT"	2
N/I	16-55-0105	BEFORE -06/95 #0000-HYDR.HOSE 3/8-H ASS 1/2-14 MALE RIG.X 1/2-14 MALE RIG.X 48" LG	2
N/I	NC13-45-0014	BEFORE -06/95 #0000-QUICK DISCON.COUPLER 1/2"-14 NPTF	1
N/I	16-55-0179	AFTER -06/95 #0000-HYDR.HOSE 3/8" Dia. X ASSY. "3 WAYS SPLITER VALVE 7/8-14 SAE"	2
N/I	16-55-0250	AFTER -06/95 #0000-HYDR.HOSE 3/8"-H ASS 1/2-14 MALE RIG X 3/8-18 MALE RIG. X 60" LG	2
N/I	NC13-45-0014	AFTER -06/95 #0000-QUICK DISCON.COUPLER 1/2"-14 NPTF	1
4	NC13-45-0073	STRAIGHT UNION 7/8-14 MALE SAE O RING X 3/8 FEM.TOUR.NPT	4
5	16-01-2280	SUPPORT LEFT	1
6	16-01-2285	SUPPORT RIGHT	1
7	NC13-45-0072	90° 7/8"-14 MALE SAE O RING X 3/8" FEM.TOUR.NPT	2
8	NC13-45-0038	ELBOW 90° 3/8 FEM.NPT X 3/8 MALE NPT	2
9	16-55-0085	BEFORE -06/95 #0000-HYDR.HOSE 3/8-H ASS. 3/8-18 MALE SWI.X 1/2-14 MALE RIG.X 180" LG	2
N/I	16-55-0110	AFTER -06/95 #0000-HYDR.HOSE 3/8-H ASS 3/8-18 MALE RIG. X 3/8-18 MALE SWI.X 180" LG	2
10	15-45-0160	BEFORE -06/95 #0000-3 WAY SPLITER VALVE"STRAIGHT FITT.7/8-14 SAE X 1/2 NPT INCLUD."	2
N/I	15-45-0161	AFTER -06/95 #0000-3 WAY SPLITER VALVE 7/8-14 SAE	2
11	16-13-0300	HYDR.SELECTOR VALVE	1
12	16-55-0090	BEFORE -06/95 #0000-HYDR.HOSE 3/8-H ASS 1/2-14 MALE RIG. X 1/2-14 MALE SWI.X 195" LG	2
N/I	16-55-0115	AFTER -06/95 #0000-HYDR.HOSE 3/8-H ASS 3/8-18 MALE SWI. X 1/2-14 MALE SWI. X 195" LG	2

GAZ MODEL
TUFF VAC 5000

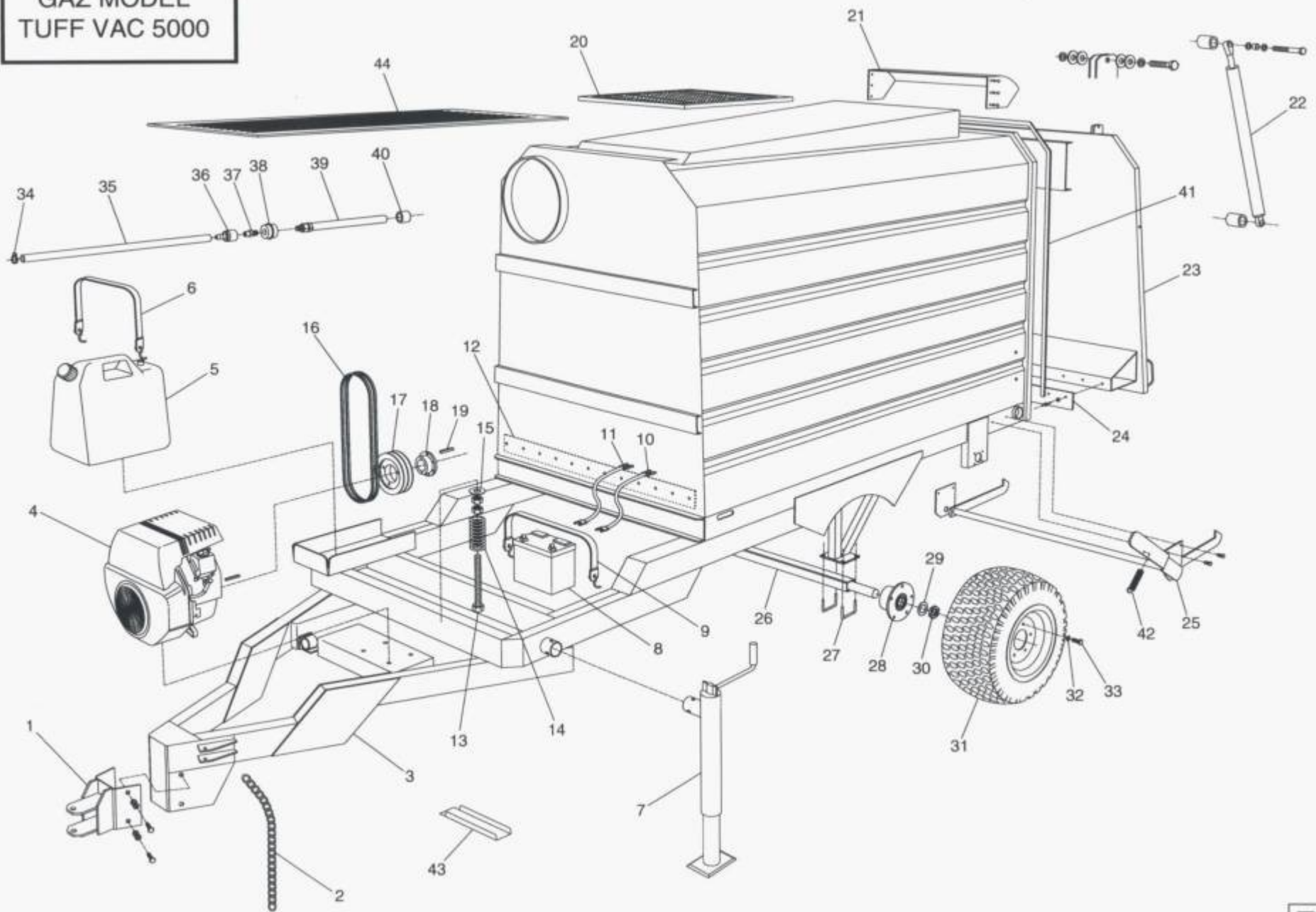

TUFF VAC 5000 GAS

REF.	PART NO.	DESCRIPTION	QTE
1	16-50-0105	HITCH	1
2	16-41-0040	SAFETY CHAIN 10MM GRADE 70 X 58" LONG	2
3	16-50-1001	BODY	1
4	16-55-0505	MOTOR GAS 20 HP ASSY	1
5	NC13-80-0002	GAS TANK (5 GALLONS)	1
6	NC13-15-0032	POLYURETHANE STRAP 24"	1
7	16-55-0249	JACK	1
8	NC13-12-0001	BATTERY (12 VOLTS)	1
9	NC13-15-0008	RUBBER STRAP 12" LG	1
10	16-55-0540	BATTERY CABLE ASSY 24" LG NEG.	1
11	16-55-0545	BATTERY CABLE ASSY 15" LG POS.	1
12	16-55-0186	RUBBER PAD ASSY. "FLAT WASHER AND POT RIVET INCLUDED"	1
N/I	16-42-0035	RUBBER PAD 45 1/2" LG	1
N/I	NC01-78-0016	ALUMINIUM RIVET 3/16" X 5/8" LG	15
N/I	16-01-2720	FLAT WASHER 13/16" Dia. X Ø 13/64" X 14 GA	15
13	16-55-0530	BELT TIGHTENER	1
14	NC13-86-0077	BLUE SPRING 1 1/2" Dia. X Ø 3/4" X 4" LG	1
15	17-09-0500	FLAT WASHER 1 3/4" Dia. X 3/4" X 1/4" LG	1
16	NC14-25-0554	V-BELT B-40	2
17	NC14-62-0099	CAST IRON SHAVE PULLEY 3B5.0 SD	1
18	NC14-62-0003	TAPERED QD BUSHING SD 1" KW 1/4"	1
19	01-41-0910	SQUARE KEY 1/4" X 1/4" X 1 1/2" LG	7
20	16-55-0060	OPT.HARD SURFACE FILTER ASSY.	4
21	16-50-0165	DEFLECTOR "EXTENSION"	1
22	NC13-80-0005	GAS CYLINDER	2
23	16-55-0266	BACK DOOR "STICKER INCLUDED"	1
24	16-55-0185	DOOR RUBBER PAD ASSY. "FLAT WASHER AND POT RIVET"	1
N/I	16-42-0030	RUBBER PAD " DOOR "46 1/4" LG	1
N/I	NC01-78-0016	ALUMINIUM RIVET 3/16" X 5/8" LG	15
N/I	16-01-2720	FLAT WASHER 13/16" Dia. X Ø 13/64" X 14 GA	15
25	16-50-0150	DOOR LATCH	1
26	16-50-0060	AXLE	1
27	16-13-0600	AXLE COLLAR	4
28	16-55-0055	HUB ASSY.	2
N/I	16-50-0100	HUB	2
N/I	NC14-75-0071	BALL BEARING 6207-2RS	4
29	16-09-1005	FLAT WASHER 2" Dia. X Ø 1 3/8" X .125" LG	2
30	NC01-98-0021	NYLON INSERT LOCKNUTS 1 1/4"-18	2
31	16-55-0050	WHEEL 23" ASSY.	2
N/I	NC14-70-0001	TIRE 23-10.5 X 4 PLIS TBL	2
N/I	16-55-0051	RIM 12" Dia.	2
N/I	NC14-70-0003	VALVE TBL TR-13	2
32	NC02-32-0014	LOCK WASHER Ø 1/2"	10
33	NC01-29-0248	HEX.BOLT 1/2"-20 X 1 1/4" LG (GRADE 5)	10
34	NC01-65-0053	COLLAR (MH4)	2
35	16-46-0930	GAS LINE 30" LG "MOTOR"	1
36	NC01-80-0002	FEMALE GAS LINE NIPPLE	1
37	NC01-80-0003	GAS LINE NIPPLE MALE	1
38	16-42-0100	CAP GAS LINE 1 5/8" Dia. X 1 1/8" LG	1
39	16-55-0555	GAS LINE ASSY. 14" LG "TANK"	1
40	01-09-0105	BUSHING 1" Dia. X 1/2" X 1 1/8" LG	2
41	16-42-0220	FOAM STICKER 148" LG	1
42	NC13-85-0008	SPRING 7/8" Dia. X 5" LG	1
43	01-55-0030	DRAIN OIL SLAB "STICKER INCLUDED"	1
44	16-03-4800	EXHAUST SCREEN	1

GAZ MODEL
TUFF VAC 5000

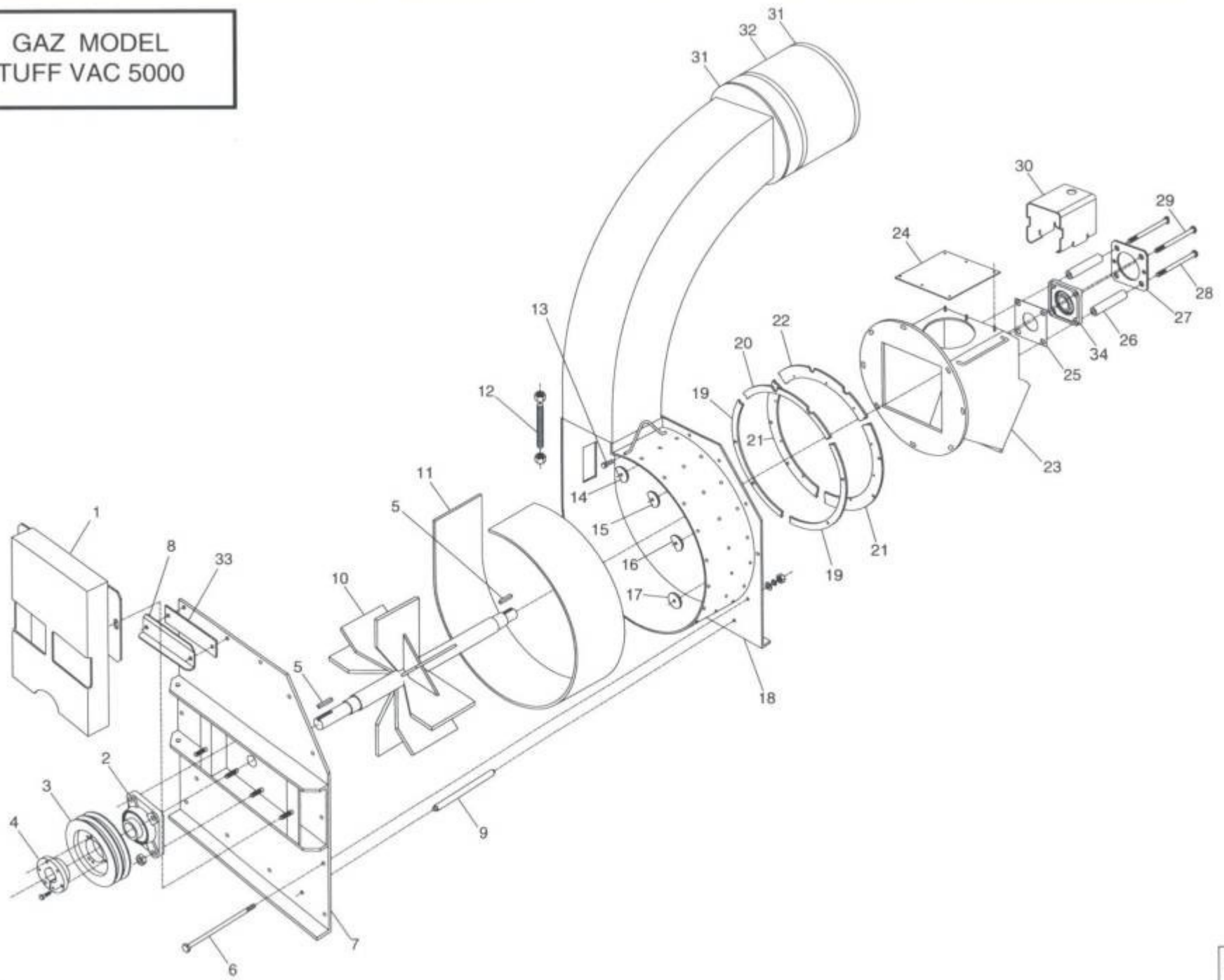

TUFF VAC 5000 GAS

REF.	PART NO.	DESCRIPTION	QTE
1	16-01-3065	BELT GUARD	1
2	16-38-0000	FLANGE BEARING SPECIAL 4 Ø UCF 207-20 X Ø 1 1/4"	1
3	NC14-62-0089	CAST IRON SHAVE PULLEY 2B5.6 SDS	1
4	NC14-62-0011	TAPERED QD BUSHING SDS 1 1/4" KW 1/4"	1
5	01-41-0910	SQUARE KEY 1/4" X 1/4" X 1 1/2" LG	5
6	NC01-17-0146	HEX. BOLT 3/8"-16 X 9" LONG (GRADE 2)	14
7	16-50-0160	BLOWER CASING COVER "STICKER INCLUDED"	1
8	16-01-2295	EJECTION CHUTE PROTECTOR	1
9	16-13-0805	BLOWER CASING SPACER 5/8" Dia.X 8 1/4" LG	2
10	16-50-0046	IMPELLER	1
11	16-50-0110	WEAR LINER	1
12	16-31-0250	LINER ADJUSTMENT ROD 5/8"-11 X 5 3/4" LG	1
13	16-30-9955	SUCTION BOX FLANGE STOPPER 3/8"-16 X 1 1/4" LG	1
14	16-13-2815	BOLT HEAD PROTECTOR 2" Dia. X 3/8" LG	1
15	16-13-2810	BOLT HEAD PROTECTOR 2" Dia. X 3/8" LG	1
16	16-13-2805	BOLT HEAD PROTECTOR 2" Dia. X 3/8" LG	1
17	16-13-2820	BOLT HEAD PROTECTOR 2" Dia. X 3/8" LG	5
18	16-50-0180	BLOWER CASING "STICKER INCLUDED"	1
19	16-04-0300	FLANGE SHIM	2
20	16-04-0295	SUCTION BOX FLANGE SHIM	1
21	16-04-6810	SUCTION BOX FLANGE STOPPER	2
22	16-04-6805	SUCTION BOX FLANGE STOPPER	1
23	16-50-0175	SUCTION BOX "STICKER INCLUDED"	1
24	16-55-0220	SUCTION BOX COVER "STICKER INCLUDED"	1
25	16-01-3145	BEARING SHIM	1
26	16-09-0800	BUSHING 1" X 1/2" X 4 3/4" LG	4
27	16-04-6855	HYDRAULIC PUMP SUPPORT	1
28	NC01-17-0269	HEX.BOLT 1/2"-13 X 6 1/2" LG (GRADE 2)	2
29	16-30-9965	BOLT 1/2"-13 X 6 1/2" LG (GRADE 2) SPECIAL	2
30	16-55-0216	CHAIN COUPLING GUARD "STICKER INCLUDED"	1
31	NC01-65-0082	COLLAR (HAS224)	2
32	16-42-0065	HOSE CHUTE 13" Dia.	1
33	16-42-0225	FOAM STICKER 8" LG	1
34	12-38-0001	FLANGE BEARING 4 Ø UCF 207-20 X Ø 1 1/4" (GREASE FITTING 1/4"-28)	1

PICK-UP HEAD
WITH
ROTARY BRUSH
TUFF VAC 5000

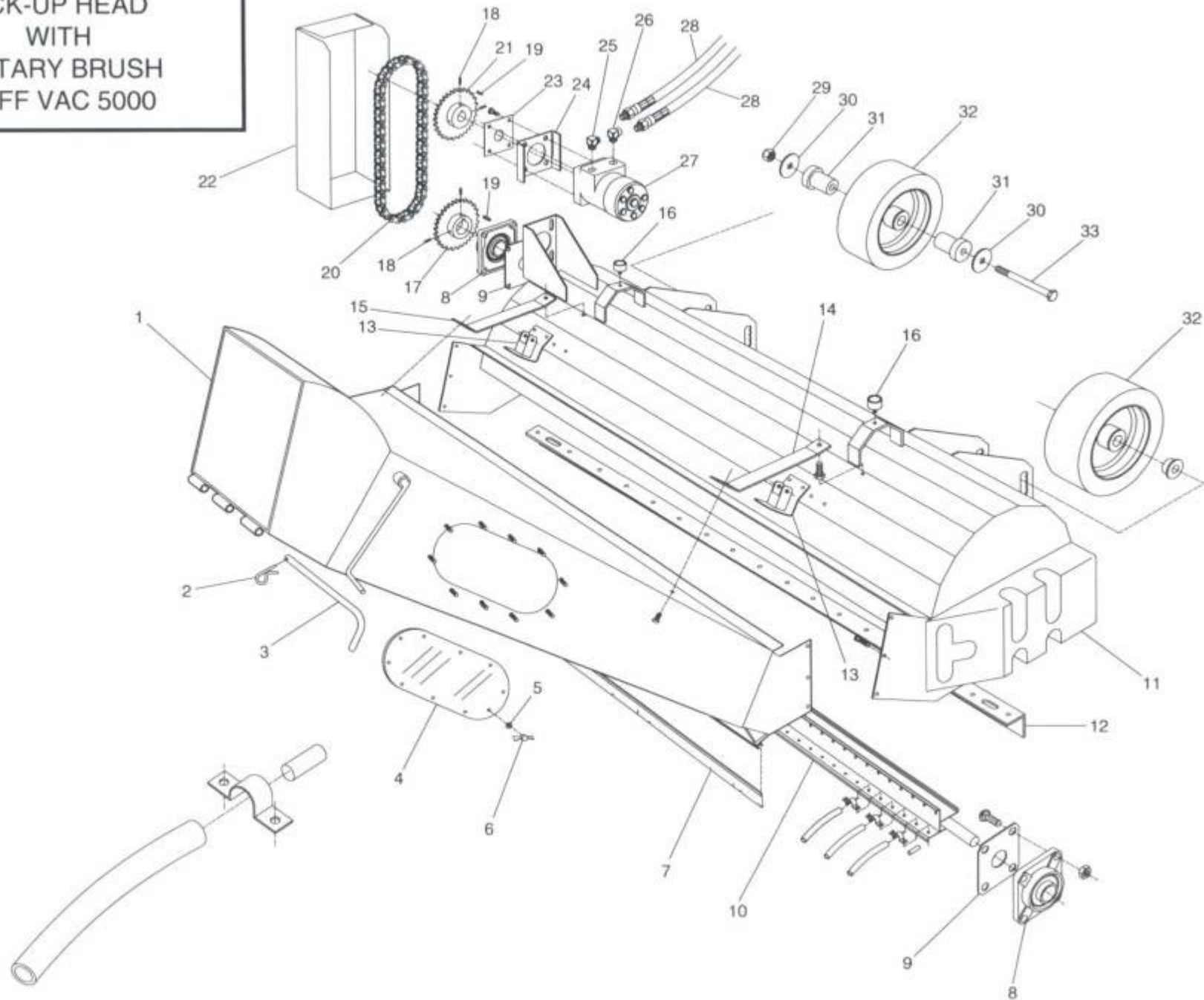

TUFF VAC 5000 PTO

REF.	PART NO.	DESCRIPTION	QTE
1	16-50-0185	VACUUM DUCT	1
2	NC01-63-0015	HITCH PIN CLIPS 1/8" X 2 5/8" LG	1
3	16-13-0610	HINGE PIN	1
4	16-42-0010	CLEAR ACCES DOOR 12" X 7" X 1/16"	2
5	01-01-2485	FLAT WASHER 13/16" Dia. X Ø 25/64" X 14GA	20
6	NC02-16-0008	WING NUT 3/8"-16	20
7	NC13-80-0051	BLACK NYLON BRUSH 60" LG	1
8	12-38-0001	FLANGE BEARING 4 Ø UCF 207-20 X Ø 1 1/4" (GREASE FITTING 1/4"-28)	3
9	16-01-1010	ROTARY BRUSH CASING END REINFORCEMENT 5 1/8" X 5 1/8" X 10GA	2
10	16-55-0135	ROTARY BRUSH ASSY.	1
11	16-50-0140	ROTARY BRUSH CASING	1
12	16-55-0236	SUCTION CASING RESTRICTOR ASSY.	1
N/I	16-01-2685	SUCTION CASING RESTRICTOR	1
N/I	NC01-29-0003	HEX.BOLT.1/4"-28 X 5/8" LG (GRADE 5)	13
N/I	NC01-37-0004	HEX.BOLT 1/4"-28 X 3/4" LG (GRADE 8)	6
N/I	NC01-97-0004	NYLON INSERT LOCKNUTS 1/4"-28	19
13	16-55-0231	STEEL CABLE FIXING REINFORCEMENT ASSY.	2
N/I	16-50-0145	STEEL CABLE FIXING REINFORCEMENT	2
N/I	NC01-37-0004	HEX.BOLT 1/4"-28 X 3/4" LG (GRADE 8)	4
N/I	NC01-97-0004	NYLON INSERT LOCKNUTS 1/4"-28	4
14	16-05-1005	PICK-UP HEAD LEFT SUPPORT	1
15	16-05-1010	PICK-UP HEAD RIGHT SUPPORT	1
16	NC13-15-0034	RUBBER ABSORBER	2
17	NC14-55-0204	SPROCKET 50B24H X Ø 1 1/4" KW 1/4" 2SS 5/16"-18	1
18	NC02-44-0103	ALLENS SET SCREW 5/16"-18 X 3/8" LG	2
19	01-41-0910	SQUARE KEY 1/4" X 1/4" X 1 1/2" LG	7
20	16-37-6100	CHAIN #530 MOTO "0"- RING X 35 1/4" LG	1
21	NC14-55-0164	SPROCKET 50B24H X Ø 1" KW 1/4" 2SS 5/16"-18	1
22	16-55-0267	CHAIN GUARD "STICKER INCLUDED"	1
23	16-01-2115	HYDR.MOTOR SUPPORT REINFORCEMENT	1
24	16-01-2110	HYD.MOTOR SUPPORT REINFORCEMENT	1
25	16-45-6007	90° FEMALE 1/2 NPT X MALE 1/2 NPT (SPECIAL)	1
26	NC13-45-0025	90° FEMALE 1/2 NPT X MALE 1/2 NPT	2
27	NC14-45-0006	HYDRAULIC MOTOR	1
28	16-55-0125	HYDR.HOSE 1/2-H ASSY 1/2-14 MALE RIG.X 1/2-14 MALE SWI. X 48" LG	2
29	NC01-96-0014	NYLON INSERT LOCKNUTS 1/2"-13	2
30	16-04-0112	FLAT WASHER (ADJUSTABLE WHEEL) 2" Dia. X Ø 33/64" X 3/16"	4
31	16-13-2825	ADJUST.WHEEL AXLE 2" Dia. X Ø 33/64" X 2 1/4" LG	4
32	16-55-0100	HARD WHEEL ASSY.	2
N/I	16-55-0264	HARD WHEEL "NO BEARING"	2
N/I	NC14-70-0027	ROLLER BEARING	2
N/I	04-13-3400	SHOULDER BUSHING 2 3/8" Dia. X Ø 1 1/64" X 1/2" LG	4
33	NC01-17-0267	HEX. BOLT GRADE 2 1/2"-13 X 6" LG	2

16-55-0135

#	PART #	Qty	TITLE
1	16-50-0170	1	ROTOR
2	16-55-0140	92	FINGER
3	16-01-0005	4	RUBBER FINGER HOLDER
4	16-01-0010	20	RUBBER FINGER HOLDER
5	NC01-97-0004	96	NYLON-INSERT LOCKNUT ZINC 1/4-28
6	NC01-37-0008	96	HEX. BOLT GR8 1/4-28 X 1 1/2"

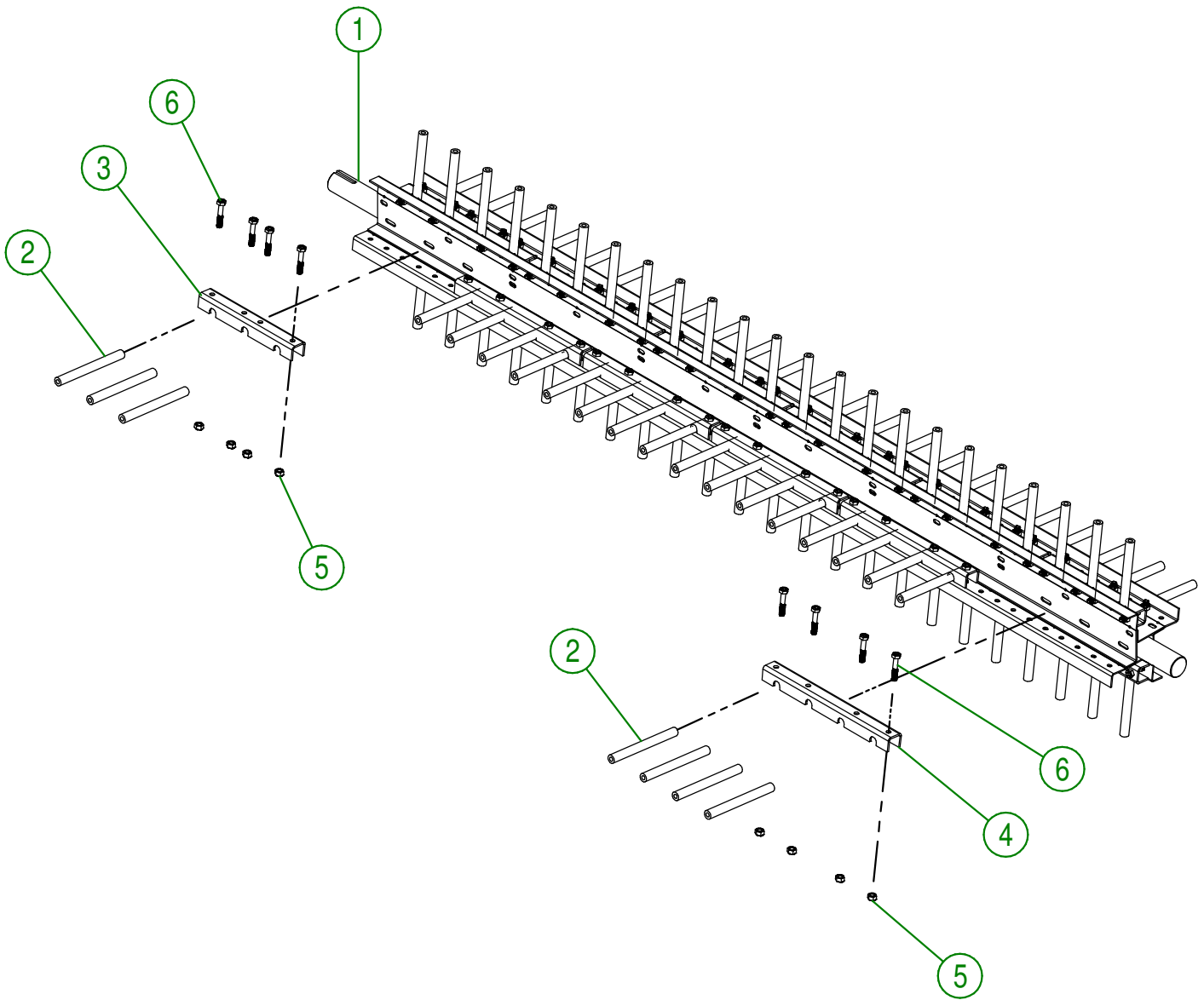

AGRIMETAL	
BRUSH ASSEMBLY	
CREATION : 31/08/21	ASSEMBLY : 16-55-0135
REVISION : 31/08/21	AUTHOR : J. Houle

PICK-UP HEAD
HYDRAULIC
LIFTING SYSTEM
TUFF VAC 5000

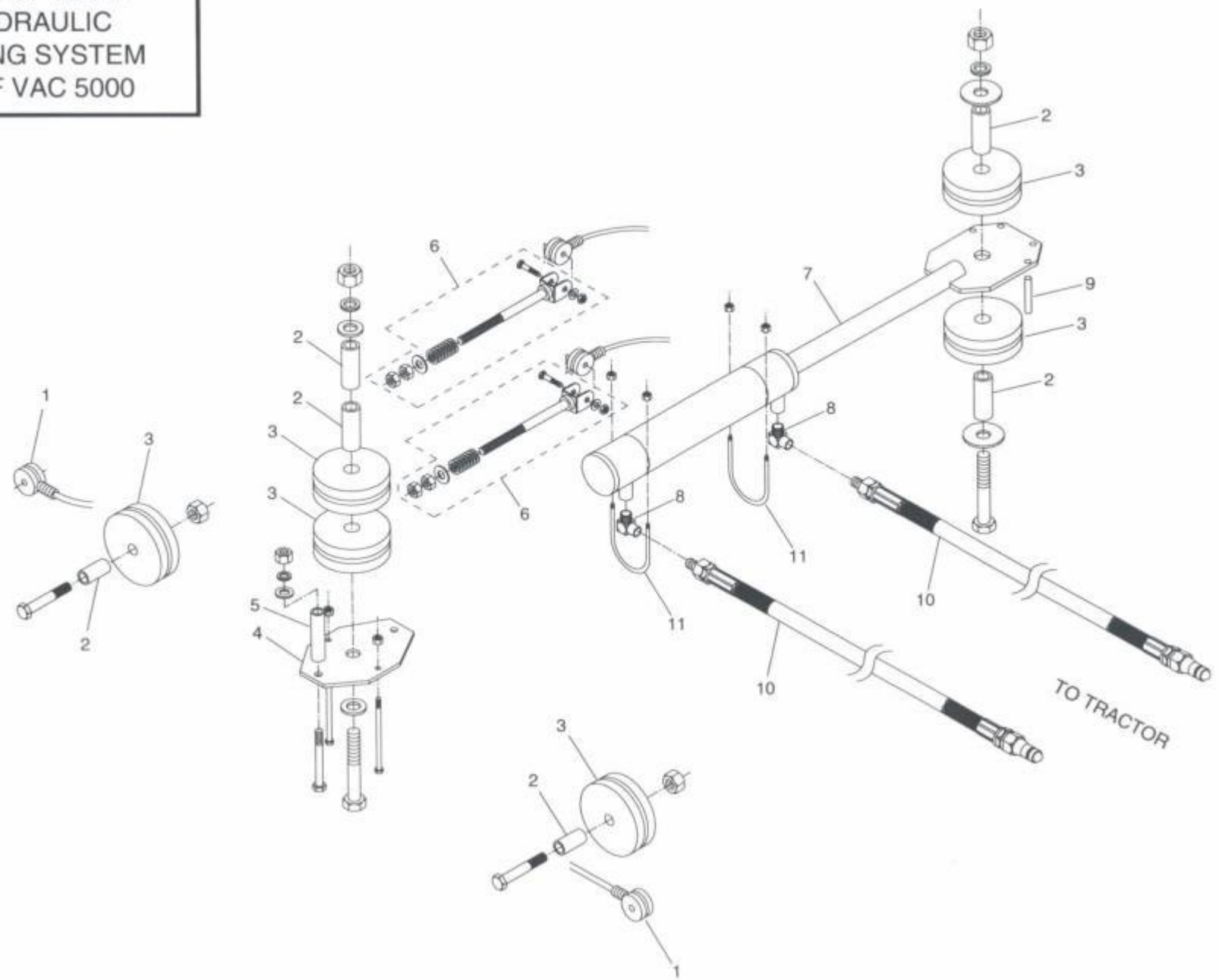

TUFF VAC 5000 PTO

REF.	PART NO.	DESCRIPTION	QTE
1	16-55-0188	LIFTING CABLE FOR PICK-UP HEAD ASSY. "WITH BRUSH"	2
2	12-09-0100	BUSHING 3/4" Dia. X Ø 1/2" X 1 5/16" LG	6
3	12-42-0100	U.H.M.W. IDLER PULLEY 4" Dia. X 1 1/4" THICK	6
4	16-01-0990	PULLEY SUPPORT	1
5	16-09-0605	BUSHING 3/4" Dia. X Ø 33/64" X 2 5/8" LONG	1
6	16-55-0175	STEEL CABLE TIGHTENER ASSY.	2
N/I	16-50-0135	STEEL CABLE TIGHTENER BOLT	2
N/I	NC13-86-0143	RED SPRING 1/2" Ø X 1" X 2" LONG	2
7	16-50-0155	BRUSH HYDRAUL.CYLINDER	1
8	NC13-45-0038	ELBOW 90° 3/8 FEM.NPT X 3/8 MALE NPT	2
9	NC01-69-0465	SPRING PIN 1/4" X 2" LG	4
10	16-55-0084	HYDRAUL.HOSE 3/8" Dia. ASSY. PICK-UP HEAD "QUICK DISCON.COUPLER INCUDED"	2
N/I	16-55-0085	HYDR.HOSE 3/8-H ASS. 3/8-18 MALE SWI.X 1/2-14 MALE RIG.X 180" LG	2
N/I	NC13-45-0014	QUICK DISCON.COUPLER 1/2"-14 NPTF	2
11	NC01-61-0002	U BOLT 3/8"-16	2

STANDARD PICK-UP HEAD
TUFF VAC 5000

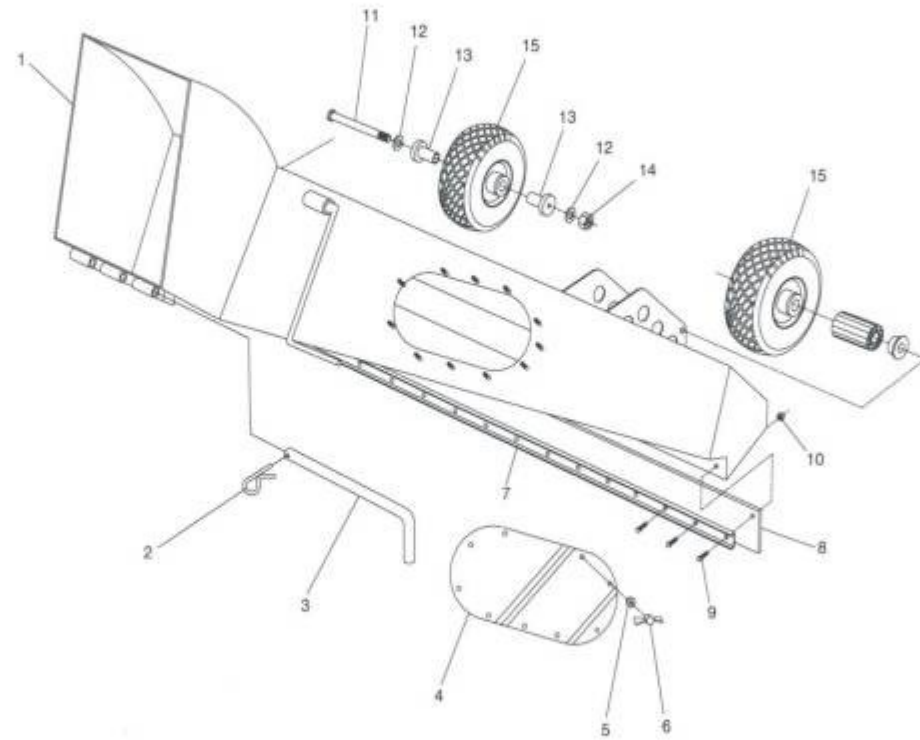

TUFF VAC 5000 GAS

REF.	PART NO.	DESCRIPTION	QTE
1	16-50-0190	PICK-UP HEAD WITHOUT BRUSH	1
2	NC01-63-0015	HITCH PIN CLIPS 1/8" X 2 5/8" LG	1
3	16-13-0610	HINGE PIN	1
4	16-42-0010	CLEAR ACCES DOOR 12" X 7" X 1/16"	2
5	01-01-2485	FLAT WASHER 13/16" Dia. X Ø 25/64" X 14GA	20
6	NC02-16-0008	WING NUT 3/8"-16	20
7	16-01-2745	RUBBER REINFORCEMENT 60" LG	1
8	16-42-0075	RUBBER 60" LG	1
9	NC01-37-0004	HEX.BOLT 1/4"-28 X 3/4" LG (GRADE 8)	21
10	NC01-97-0004	NYLON INSERT LOCKNUTS 1/4"-28	21
11	NC01-17-0267	HEX. BOLT GRADE 2 1/2"-13 X 6" LG	2
12	16-04-0112	FLAT WASHER (ADJUSTABLE WHEEL) 2" Dia. X Ø 33/64" X 3/16"	4
13	16-13-2015	ADJUST.WHEEL AXLE 1 1/2" Dia. X Ø 33/64" X 2 1/4" LG	4
14	NC01-96-0014	NYLON INSERT LOCKNUTS 1/2"-13	2
15	NC14-70-0019	WHEEL 10" Dia. ASSY.	2
N/I	NC14-70-0049	TIRE 4.10/3.50-4	2
N/I	NC14-70-0055	RIM 4" Dia.	2
N/I	NC14-70-0030	TUBE 3.50-4	2
N/I	NC14-70-0021	ROLLER BEARING X Ø 3/4"	2
N/I	NC14-70-0057	STEEL SHOULDER BUSHING X Ø 3/4"	4

PICK-UP HEAD
STANDARD
LIFTING SYSTEM
TUFF VAC 5000

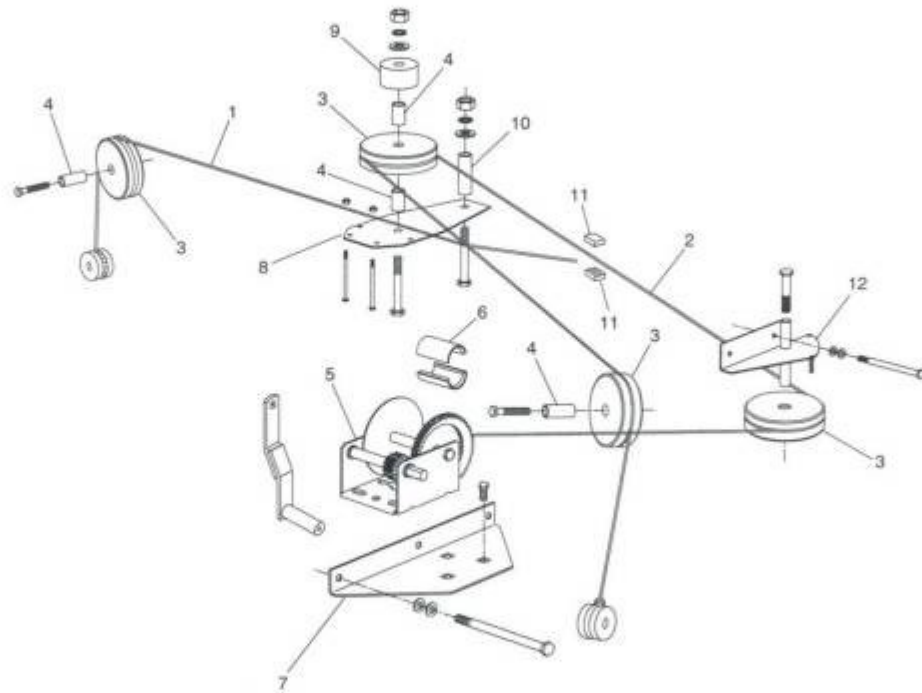

TUFF VAC 5000 PTO

REF.	PART NO.	DESCRIPTION	QTE
1	16-55-0252	LIFFTING CABLE FOR PICK-UP HEAD ASSY. "WITHOUT BRUSH" MANUAL	1
2	16-55-0251	LIFFTING CABLE FOR PICK-UP HEAD ASSY. "WITHOUT BRUSH" MANUAL	1
3	12-42-0100	U.H.M.W. IDLER PULLEY 4" Dia. X 1 1/4" THICK	4
4	12-09-0100	BUSHING 3/4" Dia. X Ø 1/2" X 1 5/16" LG	4
5	NC13-80-0088	WINCH MANUAL	1
6	16-42-0125	WINCH HALF-BUSHING 1 1/4" Dia. X 2" LONG	2
7	16-01-1015	WINCH SUPPORT	1
8	16-01-0990	PULLEY SUPPORT	1
9	16-42-0120	PULLEY SPEACER 2" Dia. X 1 1/4" LG	1
10	16-09-0605	BUSHING 3/4" Dia. X Ø 33/64" X 2 5/8" LONG	1
11	16-05-2520	CABLE SECURING	2
12	16-50-0205	PULLEY SUPPORT	1

STICKER TUFF VAC 5000 PTO MANUAL AND HYDRAULIC

REF.	PART NO.	DESCRIPTION	QTE
N/I	16-58-0020	STICKER KIT (TUFF VAC 5000 PTO MANUAL)	1
N/I	NC13-33-0105	STICKER CAUTION / READ OPERATOR'S MANUAL BEFORE STARTING...	2
N/I	NC13-33-0113	STICKER WARNING MISSING SHIELD HAZARD...	1
N/I	NC13-33-0096	STICKER WARNING PINCH POINT HAZARD	2
N/I	NC13-33-0102	STICKER REFLECTOR (TRIANGLE)	1
N/I	16-60-0050	STICKER REFLECTOR (2" X 9 " LG: RED)	2
N/I	NC13-33-0112	STICKER DANGER BLOWER BLADE HAZARD...	4
N/I	NC13-33-0119	STICKER HEAD HOSE	1
N/I	NC13-33-0098	STICKER WARNING ROTATING BLADE HAZARD...	1
N/I	01-60-0000	STICKER AGRIMÉTAL INC "LARGE"	1
N/I	15-60-0010	STICKER WARNING HIGH-PRESSURE FLUID HAZARD...	2
N/I	01-60-0040	STICKER MAXIMUM 540 RPM	1
N/I	04-60-0040	STICKER IMPORTANT 2 1/4 INCHES 60 MM	2
N/I	01-60-0115	STICKER WARNING ROTATING PART HAZARD...	1
N/I	16-60-0005	STICKER COMMERCIAL VAC SYSTEM	2
N/I	16-60-0020	STICKER DANGER THROWN OBJECT HAZARD...	2
N/I	16-60-0025	STICKER FRAME LEVEL	2
N/I	16-60-0000	STICKER TUFF VAC	2
N/I	01-60-0150	STICKER ATTENTION ADJUST TRACTOR DRAWBAR AND/OR PTO SHAFT LENGTH...	1
N/I	16-60-0015	STICKER 5000	2
N/I	01-60-0125	STICKER WARNING KEEP ALL GUARDS AND SHIELDS IN PLACE...	1
N/I	01-60-0015	STICKER OIL LEVEL	3
N/I	06-60-0000	STICKER AGRIMÉTAL INC "MEDIUM"	3
N/I	NC13-33-0123	STICKER IMPORTANT 5 INCHES 125 MM	1
N/I	01-60-0070	STICKER WARNING MISSING SHIELD HAZARD...	3
N/I	03-60-0005	STICKER GREASE GUN	8
N/I	01-60-0110	STICKER WARNING ROTATING PART HAZARD...	3
N/I	16-60-0035	STICKER CAUTION THIS MACHINE IS EQUIPED WITH A CONSTANT...	1
N/I	16-60-0045	STICKER ATTENTION THIS VACUUM HAS A REPLACEABLE WEAR LINER...	1
N/I	NC13-80-0081	ANTI-SLIP 12" X 1 1/2"	2
N/I	NC13-80-0082	ANTI-SLIP 3" X 6"	2
N/I	NC13-80-0083	ANTI-SLIP 12" X 3"	2

N/I	16-58-0030	STICKER KIT (TUFF VAC 5000 PTO HYDRAULIC)	1
N/I	NC13-33-0105	STICKER CAUTION / READ OPERATOR'S MANUAL BEFORE STARTING...	2
N/I	NC13-33-0113	STICKER WARNING MISSING SHIELD HAZARD...	2
N/I	NC13-33-0096	STICKER WARNING PINCH POINT HAZARD	2
N/I	16-60-0050	STICKER REFLECTOR (2" X 9 " LG: RED)	2
N/I	NC13-33-0102	STICKER REFLECTOR (TRIANGLE)	1
N/I	NC13-33-0112	STICKER DANGER BLOWER BLADE HAZARD...	4
N/I	NC13-33-0119	STICKER HEAD HOSE	1
N/I	NC13-33-0098	STICKER WARNING ROTATING BLADE HAZARD...	2
N/I	01-60-0000	STICKER AGRIMÉTAL INC "LARGE"	1
N/I	15-60-0010	STICKER WARNING HIGH-PRESSURE FLUID HAZARD...	3
N/I	01-60-0040	STICKER MAXIMUM 540 RPM	1
N/I	04-60-0040	STICKER IMPORTANT 2 1/4 INCHES 60 MM	2
N/I	01-60-0115	STICKER WARNING ROTATING PART HAZARD...	1
N/I	16-60-0005	STICKER COMMERCIAL VAC SYSTEM	2
N/I	16-60-0020	STICKER DANGER THROWN OBJECT HAZARD...	2
N/I	16-60-0025	STICKER FRAME LEVEL	2
N/I	16-60-0000	STICKER TUFF VAC	2
N/I	01-60-0150	STICKER ATTENTION ADJUST TRACTOR DRAWBAR AND/OR PTO SHAFT LENGTH...	1
N/I	16-60-0015	STICKER 5000	2
N/I	01-60-0125	STICKER WARNING KEEP ALL GUARDS AND SHIELDS IN PLACE...	1
N/I	01-60-0015	STICKER OIL LEVEL	3
N/I	06-60-0000	STICKER AGRIMÉTAL INC "MEDIUM"	3

STICKER TUFF VAC 5000 PTO MANUAL AND HYDRAULIC

REF.	PART NO.	DESCRIPTION	QTE
N/I	NC13-33-0123	STICKER IMPORTANT 5 INCHES 125 MM	1
N/I	01-60-0070	STICKER WARNING MISSING SHIELD HAZARD...	2
N/I	03-60-0005	STICKER GREASE GUN	8
N/I	01-60-0110	STICKER WARNING ROTATING PART HAZARD...	3
N/I	16-60-0035	STICKER CAUTION THIS MACHINE IS EQUIPED WITH A CONSTANT...	1
N/I	16-60-0045	STICKER ATTENTION THIS VACUUM HAS A REPLACEABLE WEAR LINER...	1
N/I	NC13-80-0081	ANTI-SLIP 12" X 1 1/2"	2
N/I	NC13-80-0082	ANTI-SLIP 3" X 6"	2
N/I	NC13-80-0083	ANTI-SLIP 12" X 3"	2