

# AgriMetal

## PARTS LIST

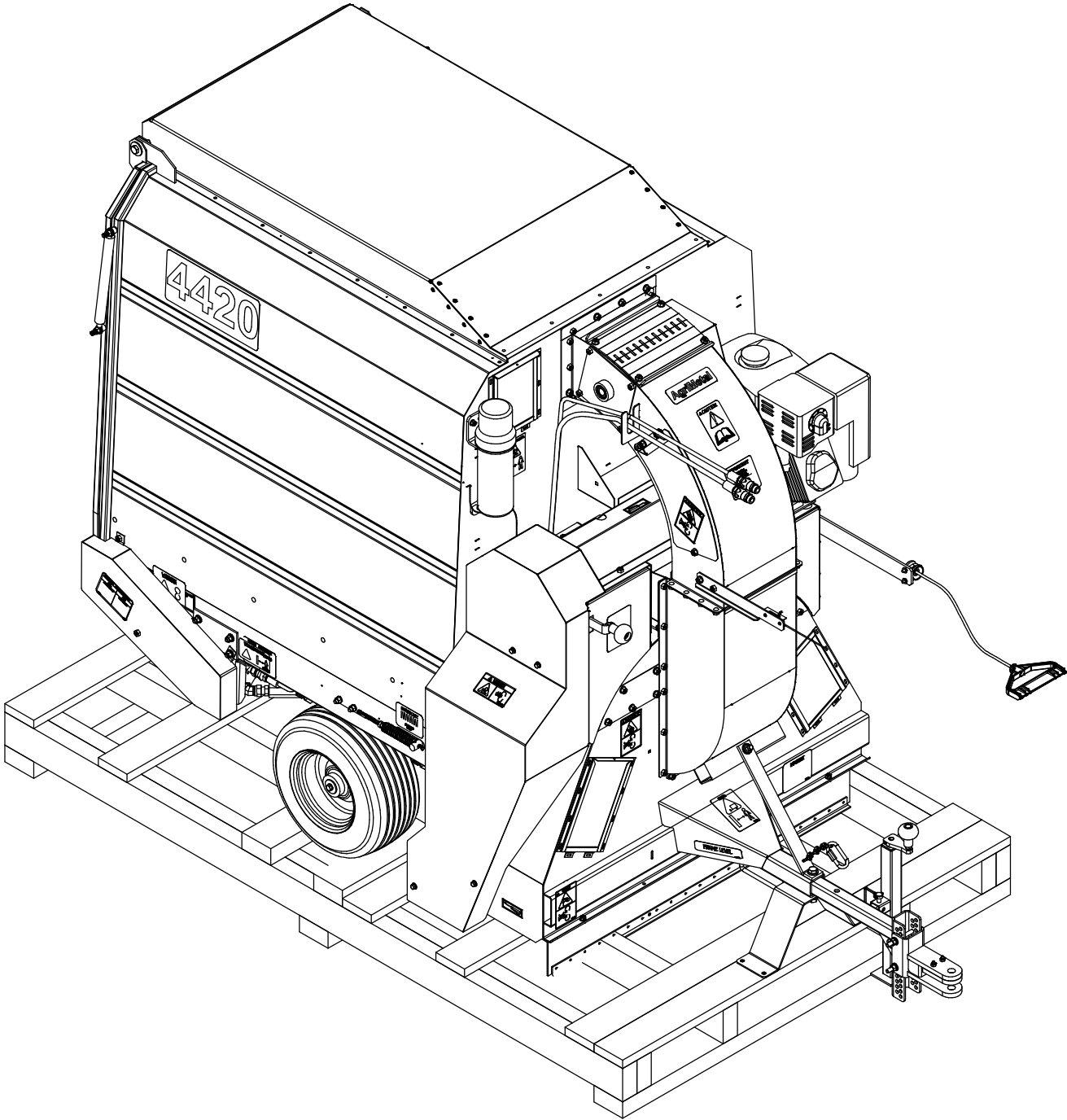

# LEAF AND DEBRIS COLLECTOR 4420

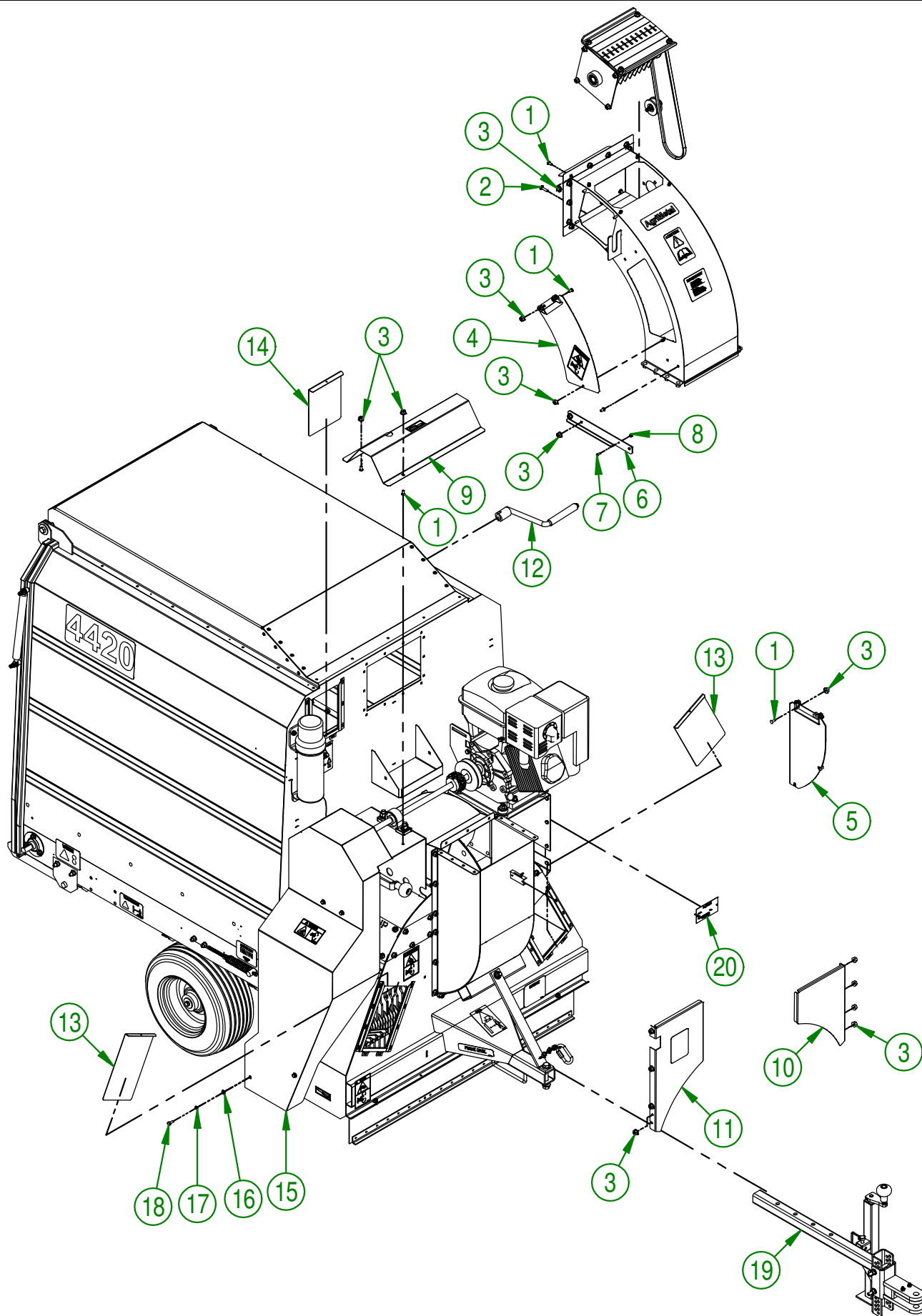

<b>AGRIMETAL</b>	
<b>LEAF COLLECTOR 4420 (HAMMER) 9 HP HONDA</b>	
CREATION : 20/09/17	ASSEMBLY : <b>23-99-0515</b>
REVISION : 26/10/18	AUTHOR : J.KABWE      Page 1 de 43

#	PART #	Qty	TITLE
1	NC01-04-0001	29	CARR. BOLT GR2 ZINC 1/4-20 X 1/2"
2	NC01-04-0005	4	CARR. BOLT GR2 ZINC 1/4-20 X 1"
3	NC02-14-0017	44	FLANGED NUT GR. B 1/4-20
4	23-55-1056	1	CHUT ELBOW ACCESS DOOR "STICKER INCLUDED"
5	23-55-0075	1	LEFT IMPELLER BOX ACCESS DOOR "STICKER INCLUDED"
6	23-01-1625	1	THROTTLE-LEVER SUPPORT
7	NC02-40-0080	2	MACHINE SCREWS SQUARE SOCKET #10-24 X 1/2" LG
8	NC01-96-0006	2	NYLON NUT ZINC 10-24
9	23-57-1233	1	BEARING DRIVE SHAFT GUARD " STICKER INCLUDED"
10	23-01-3195	1	ENGINE BASE SUPPORT GUARD
11	23-57-0243	1	BEARING SUPPORT GUARD "STICKER INCLUDED"
12	23-55-0050	1	CRANK HANDLE ASSY.
13	23-42-0005	2	CLEAR ACCESS DOOR (SUCTION BOX)
14	23-42-0010	1	CLEAR ACCESS DOOR (BOX)
15	23-57-0250	1	PULLEY GUARD " STICKER INCLUDED"
16	NC02-25-0007	4	WASHER ZINC 0.281 = 9/32
17	NC02-32-0010	4	LOCK WASHER ZINC 1/4"
18	NC01-17-0003	4	HEX. BOLT GR2 ZINC 1/4-20 X 5/8"
19	23-55-0035	1	REMOVIBLE HITCH, HAND CLIP & JACK ASSY
20	25-55-0710	1	SERIAL NUMBER PLATE

**AGRIMETAL**

LEAF COLLECTOR 4420 (HAMMER) 9 HP HONDA

CREATION : 20/09/17  
 REVISION : 26/10/18

ASSEMBLY : **23-99-0515**

AUTHOR : J.KABWE

Page 2 de 43

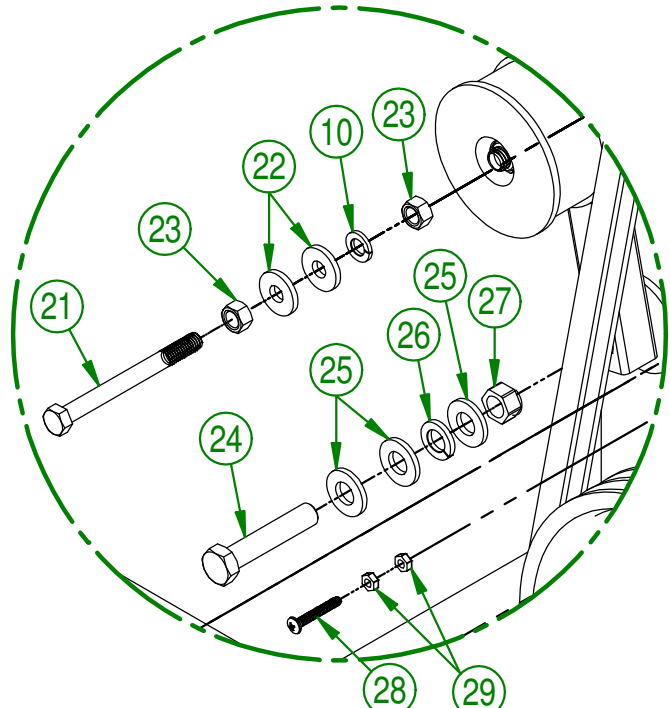
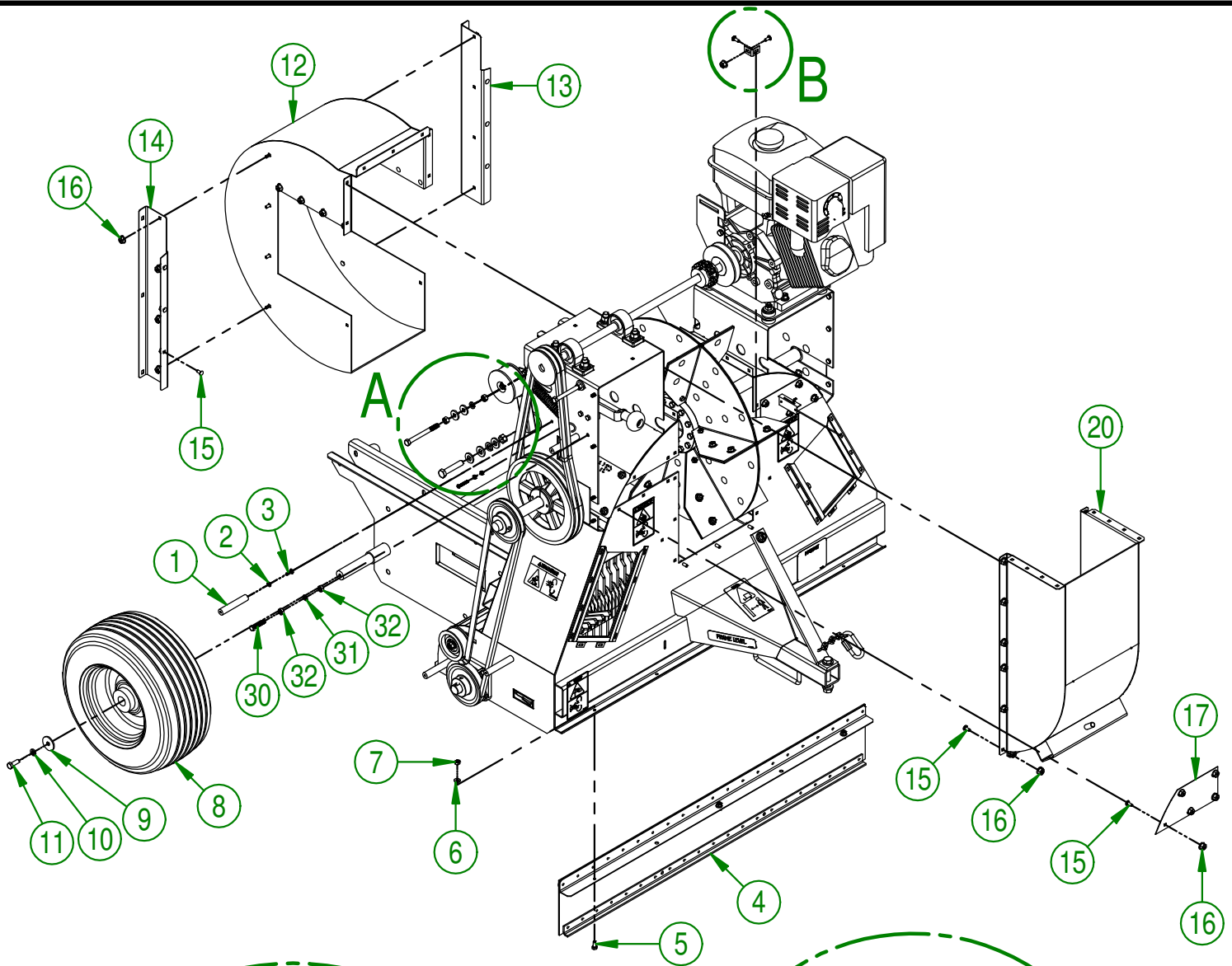

**DETAIL A**

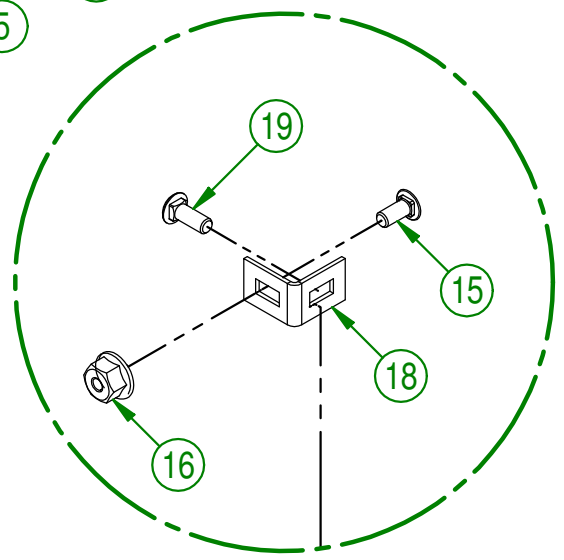

**DETAIL B**

<b>AGRIMETAL</b>	
HONDA ENGINE HAMMER SUCTION PICK-UP HEAD COMPL. ASSY.	
CREATION : 19/09/17	ASSEMBLY : <b>23-57-1096</b>
REVISION : 26/10/18	AUTHOR : J.KABWE
	Page 3 de 43

#	PART #	Qty	TITLE
1	23-21-0035	4	PULLEY GUARD SUPPORT
2	NC02-32-0010	4	LOCK WASHER ZINC 1/4"
3	NC01-29-0003	4	HEX. BOLT GR5 ZINC 1/4-28 X 5/8"
4	23-55-0095	1	RUBBER PAD ASSY.
5	NC01-17-0003	3	HEX. BOLT GR2 ZINC 1/4-20 X 5/8"
6	NC02-25-0007	3	WASHER ZINC 0.281 = 9/32
7	NC01-96-0009	3	NYLON-INSERT LOCKNUT ZINC 1/4-20
8	NC14-70-0078	2	WHEEL ASSEMBLY 16" X 6.50-8 BWT 150-180
9	01-33-0010	2	WASHER
10	NC02-32-0012	4	LOCK WASHER ZINC 3/8"
11	NC01-17-0114	2	HEX. BOLT GR2 ZINC 3/8-16 X 1"
12	23-50-0005	1	BLOWER CASING (BACK)
13	23-01-3365	1	LEFT CHANNEL BOX SUPPORT
14	23-01-3360	1	RIGHT CHANNEL BOX SUPPORT
15	NC01-04-0001	44	CARR. BOLT GR2 ZINC 1/4-20 X 1/2"
16	NC02-14-0017	49	FLANGED NUT GR. B 1/4-20
17	23-01-3350	2	SUCTION BOX ACCESS DOOR
18	23-01-2465	2	CASING BLOWER SUPPORT
19	NC01-04-0002	2	CARR. BOLT GR2 ZINC 1/4-20 X 5/8"
20	23-50-0010	1	BLOWER CASING FRONT
21	NC01-17-0126	2	HEX. BOLT GR2 ZINC 3/8-16
22	21-01-0950	4	FLAT WASHER 10GA 1.005" DIA X 25/64"
23	NC02-07-0018	4	HEX. NUT ZINC 3/8-16
24	NC01-17-0253	1	HEX. BOLT GR2 ZINC 1/2-13 X 2 1/2"
25	NC02-25-0011	3	WASHER SAE ZINC 17/32 ID
26	NC02-32-0014	1	LOCK WASHER ZINC 1/2"
27	NC01-96-0014	1	NYLON-INSERT LOCKNUT ZINC 1/2-13
28	NC02-40-0084	1	MÉCA. SCREW T. ROUND. SQUARE ZINC 10-24 X 1/4 OR 3/16 X 1/4
29	NC01-96-0006	2	NYLON NUT ZINC 10-24
30	NC01-17-0062	1	HEX. BOLT GR2 ZINC 5/16-18 X 1 1/2" TOTAL LENGTH
31	NC02-32-0011	1	LOCK WASHER ZINC 5/16"
32	NC02-07-0017	2	HEX. NUT 5/16-18

**AGRIMETAL**

HONDA ENGINE HAMMER SUCTION PICK-UP HEAD COMPL. ASSY.

CREATION : 19/09/17  
 REVISION : 26/10/18

ASSEMBLY : **23-57-1096**

AUTHOR : J.KABWE

Page 4 de 43

#	PART #	Qty	TITLE
1	23-21-0005	1	BELT TIGHTENER
2	NC17-46-0004	1	IDLER PULLEY PI-300
3	NC02-25-0011	1	WASHER SAE ZINC 17/32 ID
4	NC01-04-0115	1	CARR. BOLT GR2 ZINC 3/8-16 X 2 1/2"
5	01-01-2485	1	FLAT WASHER
6	NC02-32-0012	1	LOCK WASHER ZINC 3/8"
7	NC02-07-0018	1	HEX. NUT ZINC 3/8-16

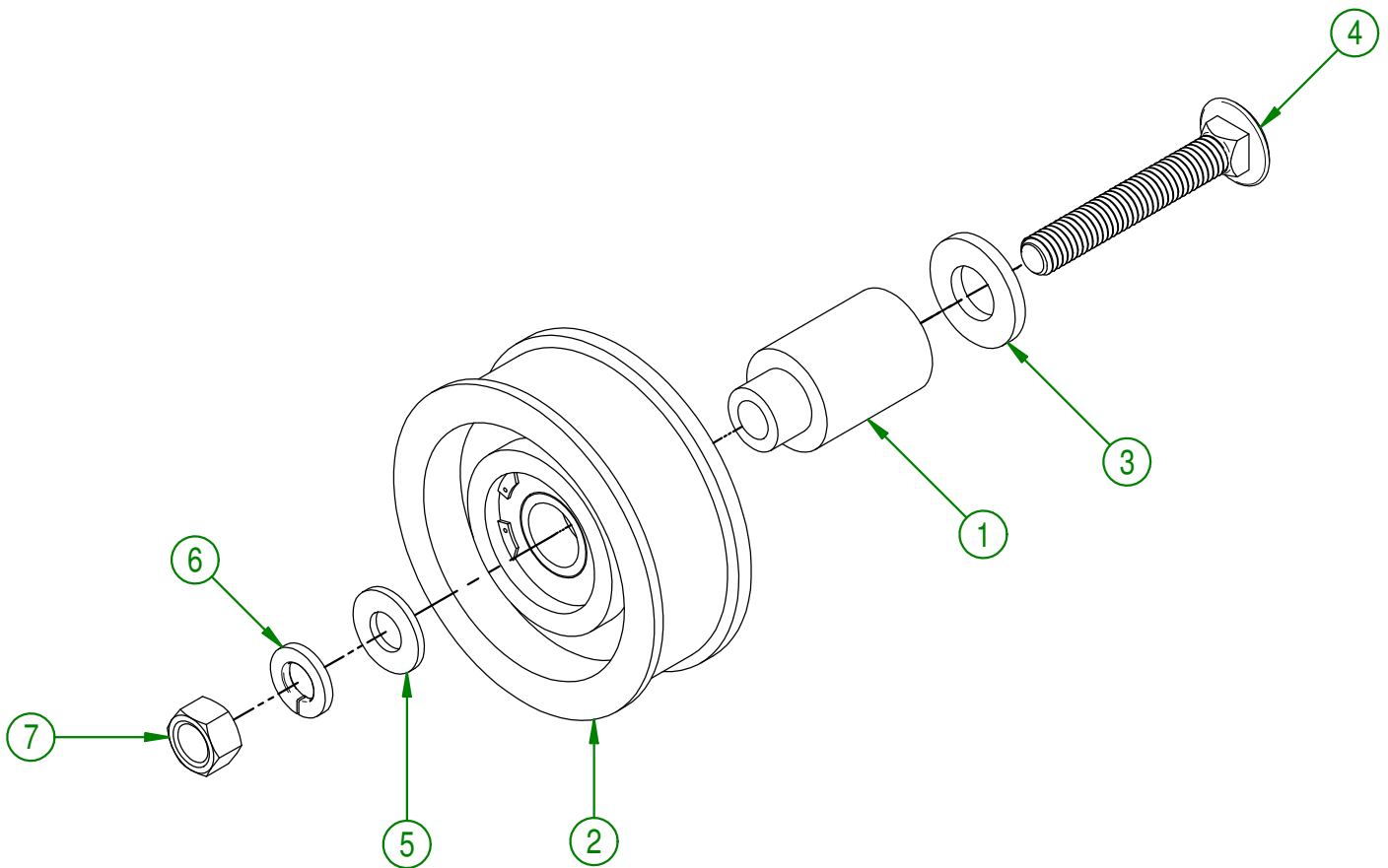

<b>AGRIMETAL</b>	
BELT TIGHTENER " IDLER PI-300" ASSY.	
CREATION : 07/12/16	ASSEMBLY : <b>23-57-0170</b>
REVISION : 25/01/18	AUTHOR : J.KABWE   Page 5 de 43

#	PART #	Qty	TITLE
1	23-55-0021	1	ROTARY ROTOR HAMMER PRE-ASS.
2	NC14-75-0023	2	FLANGE BEARING 4 HOLES UCF205-16 1" ID
3	23-01-3600	1	BEARING GUARD
4	NC01-17-0115	8	HEX. BOLT GR2 ZINC 3/8-16 X 1 1/4"
5	NC02-32-0012	8	LOCK WASHER ZINC 3/8"
6	NC02-07-0018	8	HEX. NUT ZINC 3/8-16
7	01-41-0910	1	KEY
8	NC14-62-0172	1	CAST IRON PULLEY MA45 X DIA. 1", KW 1/4 2SS
9	NC14-25-1535	1	1/2 COGGED RAW EDGE AX-57 V BELT

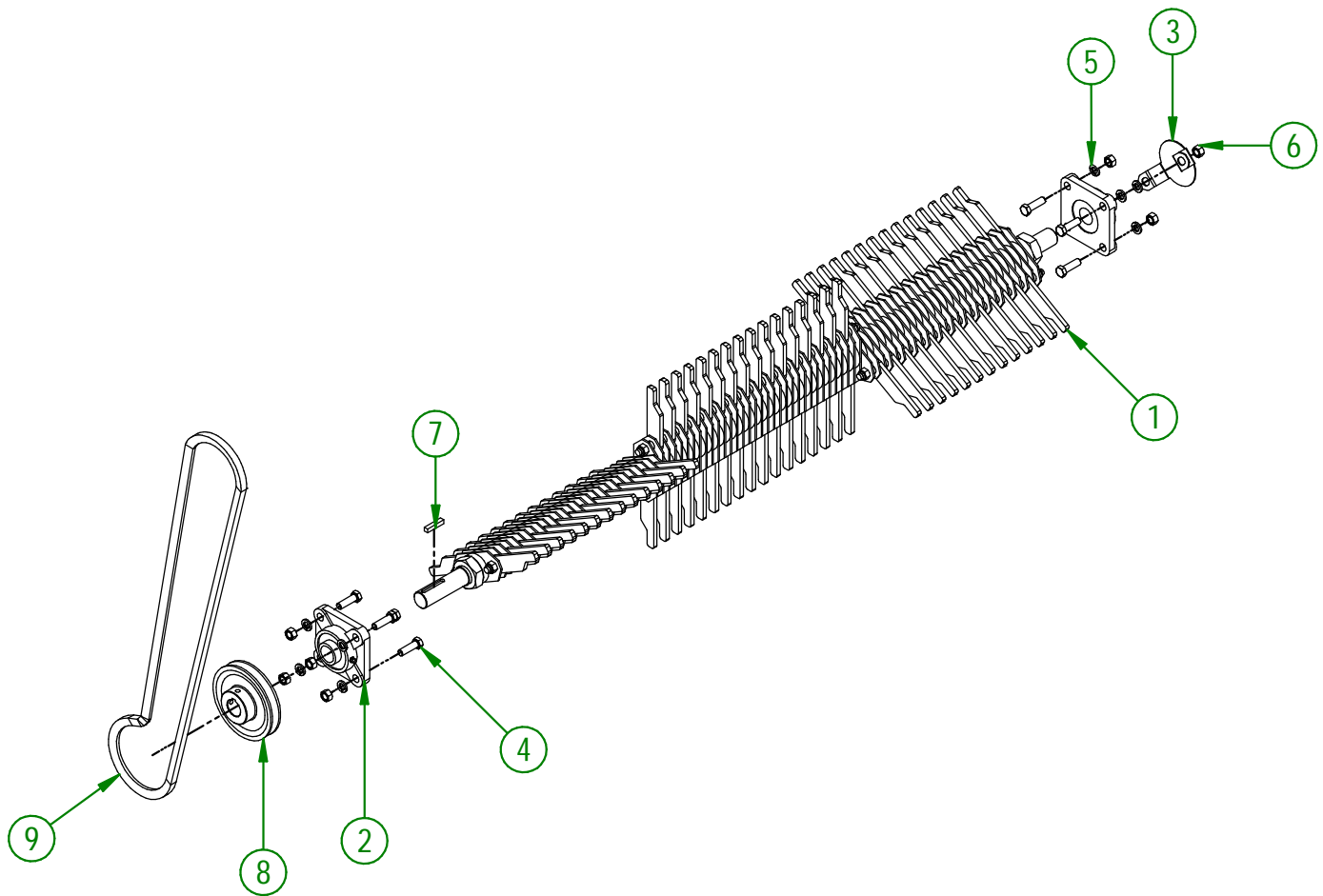

<b>AGRIMETAL</b>	
<b>ROTARY ROTOR HAMMER BRUSH GROUP.</b>	
CREATION : 07/12/16	ASSEMBLY : <b>23-57-0085</b>
REVISION : 22/02/22	AUTHOR : J.KABWE



#	PART #	Qty	TITLE
1	23-25-2400	1	ROTOR SHAFT
2	23-22-1400	90	ROTOR HAMMER SUPPORT
3	23-21-0070	2	END ROTOR RING
4	NC01-98-0020	2	NYLON NUT HEX. I 1/8 UNF-3B THIN
5	23-13-0615	4	ROTOR HAMMER PIVOT
6	23-13-0620	2	ROTOR HAMMER PIVOT
7	NC01-96-0011	12	NYLON NUT 3/8-16
8	NC17-46-0021	87	PLAST. CENTRAL ROTOR SLEEVE OD I 3/4" X ID 1.299" X 3/8" THICK
9	NC17-46-0020	87	MR AND LDC HAMMER

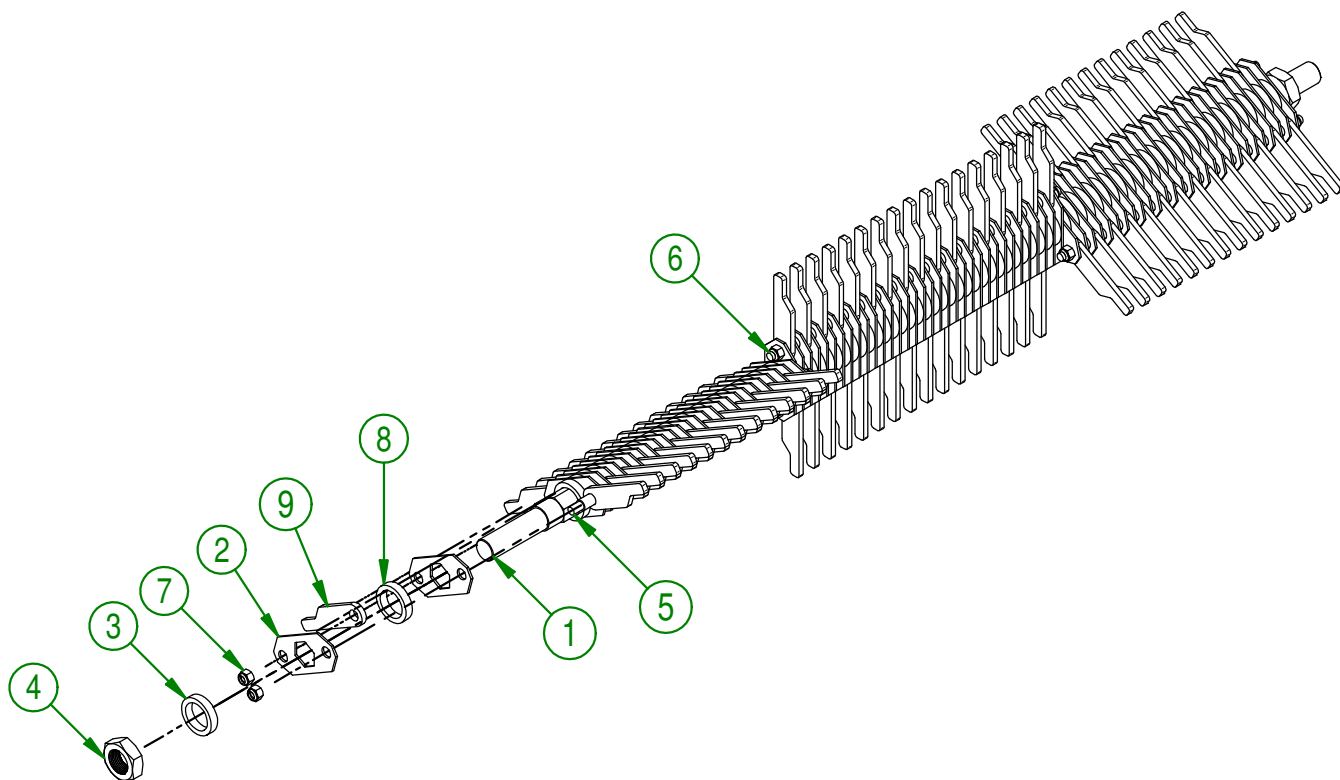

<b>AGRIMETAL</b>	
ROTARY ROTOR HAMMER PRE-ASS.	
CREATION : 07/12/16	ASSEMBLY : <b>23-55-0021</b>
REVISION : 10/01/18	AUTHOR : J.KABWE   Page 7 de 43



#	PART #	Qty	TITLE
1	23-01-3040	1	RUBBER PAD SUPPORT
2	NC13-15-0071	1	BLACK RUBBER
3	23-01-1065	1	RUBBER PAD SUPPORT
4	NC01-78-0016	42	ALUMINIUM BLIND POP RIVET STEEL MANDREL 0.187 X 0.690
5	16-01-2720	42	WASHER 13/16" DIA. X 13/64"

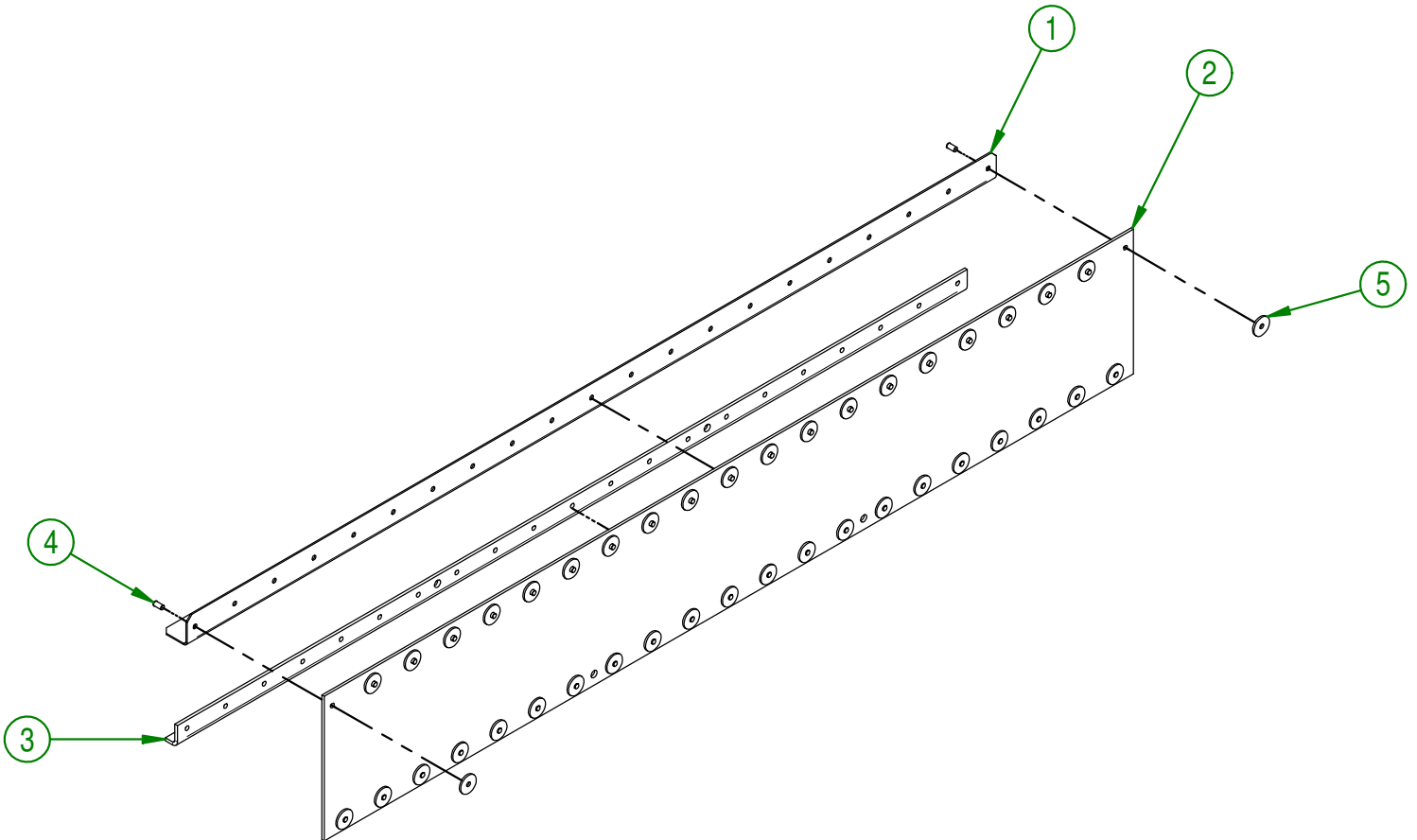

<b>AGRIMETAL</b>	
<b>RUBBER PAD ASSY.</b>	
CREATION : 07/12/16	ASSEMBLY : <b>23-55-0095</b>
REVISION : 10/01/18	AUTHOR : J.KABWE   Page 8 de 43

#	PART #	Qty	TITLE
1	23-55-0005	1	IMPELLER
2	NC14-62-0019	1	QD BUSHING SK 1 1/4"
3	23-13-1605	1	IMPELLER SHAFT
4	23-01-3375	1	IMPELLER SHAFT GUARD
5	23-01-3380	1	IMPELLER SHAFT GUARD
6	23-01-3385	2	IMPELLER SHAFT GUARD
7	NC14-75-0023	2	FLANGE BEARING 4 HOLES UCF205-16 1" ID
8	23-01-3600	1	BEARING GUARD
9	NC01-04-0110	8	CARR. BOLT GR2 ZINC 3/8-16 X 1 1/4"
10	NC02-32-0012	8	LOCK WASHER ZINC 3/8"
11	NC02-07-0018	8	HEX. NUT ZINC 3/8-16
12	01-41-0910	2	KEY
13	NC14-62-0228	1	PULLEY QD 2V A-3L-4L X 9.25 OD X L 2MAL 92
14	NC14-62-0174	1	BUSHING-BORE CAST IRON PULLEY
15	NC01-04-0001	8	CARR. BOLT GR2 ZINC 1/4-20 X 1/2"
16	NC02-14-0017	8	FLANGED NUT GR. B 1/4-20
17	NC14-62-0169	1	CAST IRON PULLEY MA40 X 1" DIA. KW 1/4 2SS

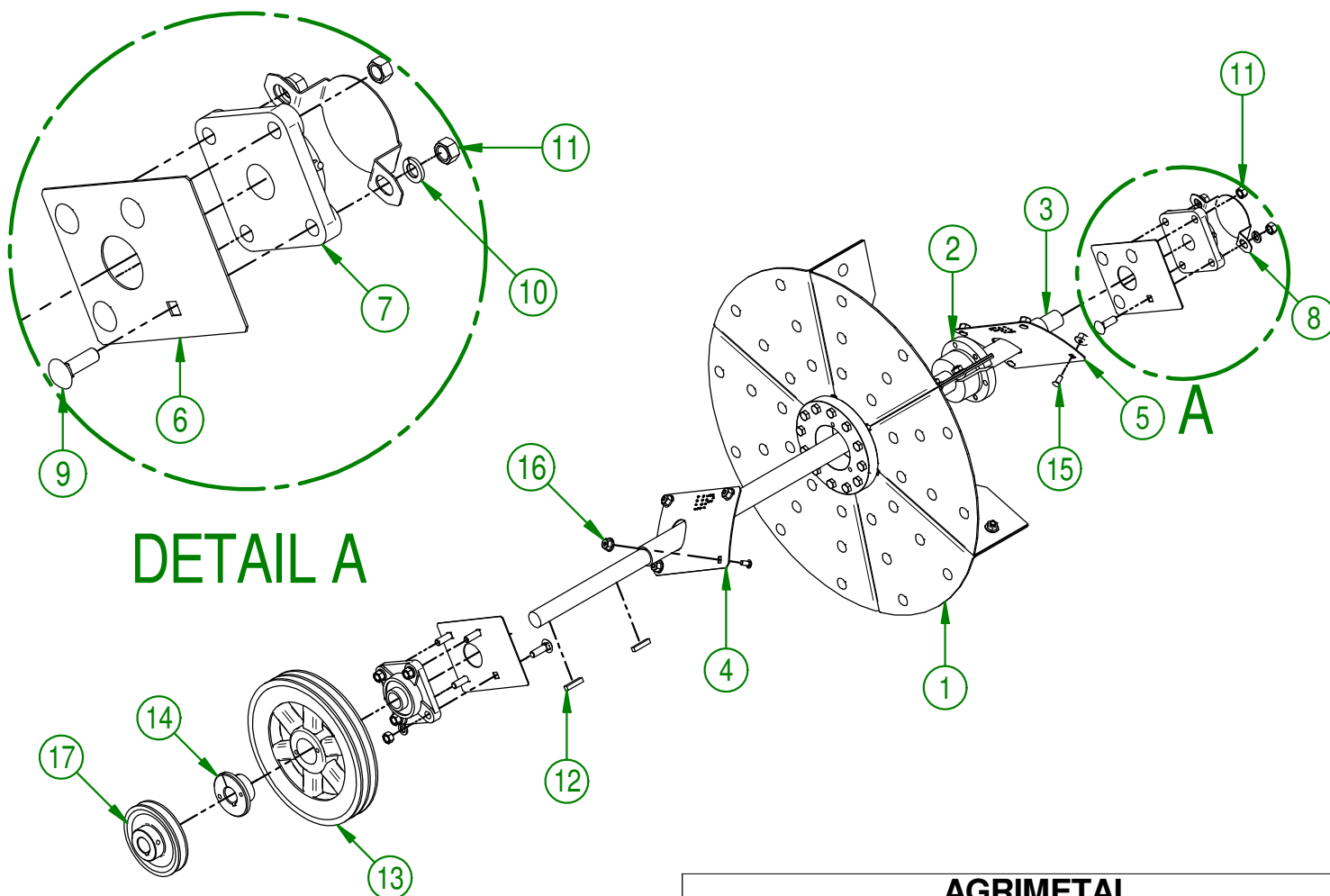

<b>AGRIMETAL</b>	
<b>IMPELLER ASSY.</b>	
CREATION : 06/12/16	ASSEMBLY : <b>23-57-0105</b>
REVISION : 16/01/19	AUTHOR : J.KABWE Page 9 de 43

23-57-0100

#	PART #	Qty	TITLE
1	23-04-0300	1	HITCH REINFORCEMENT
2	NC01-17-0257	1	HEX. BOLT GR2 ZINC 1/2-13 X 3 1/2"
3	NC02-25-0011	3	WASHER SAE ZINC 17/32 ID
4	NC02-32-0014	1	LOCK WASHER ZINC 1/2"
5	NC02-07-0020	1	HEX. NUT ZINC 1/2-13
6	NC02-07-0018	1	HEX. NUT ZINC 3/8-16
7	26-41-0000	1	SAFETY CHAIN 4.8MM X 2/0 X 58" LONG
8	NC01-75-0015	1	RAPID LINK DIA. 5/16"-8MM, 1300-1760 LBS WLL

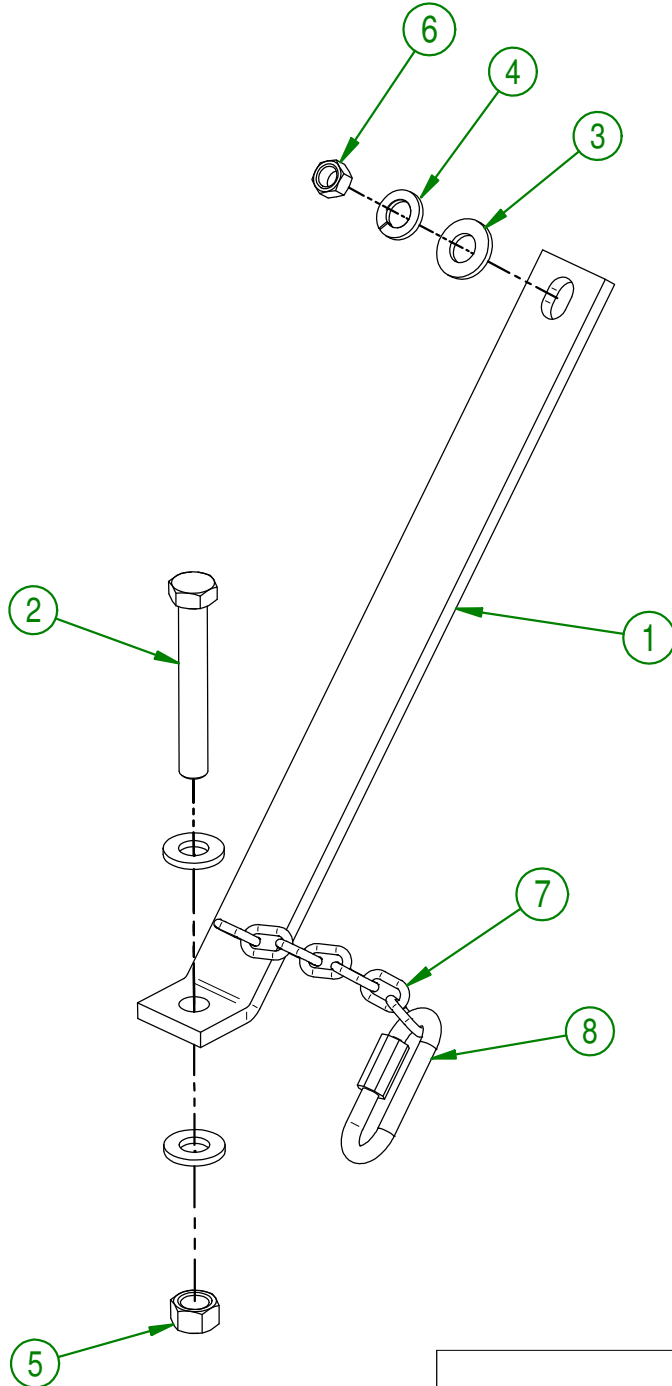

<b>AGRIMETAL</b>	
<b>HITCH REINFORCEMENT</b>	
CREATION : 06/12/16	ASSEMBLY : <b>23-57-0100</b>
REVISION : 24/01/18	AUTHOR : J.KABWE   Page 10 de 43

23-57-0125

#	PART #	Qty	TITLE
1	23-55-0065	1	BELT TIGHTENER HANDLE ASSY.
2	23-50-0060	1	BELT TIGHTENER
3	NC02-25-0011	9	WASHER SAE ZINC 17/32 ID
4	23-55-0030	1	IDLER PULLEY ASSY.
5	NC01-96-0014	1	NYLON-INSERT LOCKNUT ZINC 1/2-13
6	NC13-85-0008	1	GALVANISED SPRING

23-55-0030

#	PART #	Qty	TITLE
7	23-21-0060	1	IDLER PULLEY
8	NC14-75-0068	1	BALL BEARING 99502H
9	NC01-64-0142	1	SNAP RING HOLE 1 3/8"
10	NC13-80-0061	1	PAD STEEL POWDER 1/2" X 5/8" X 3/8"

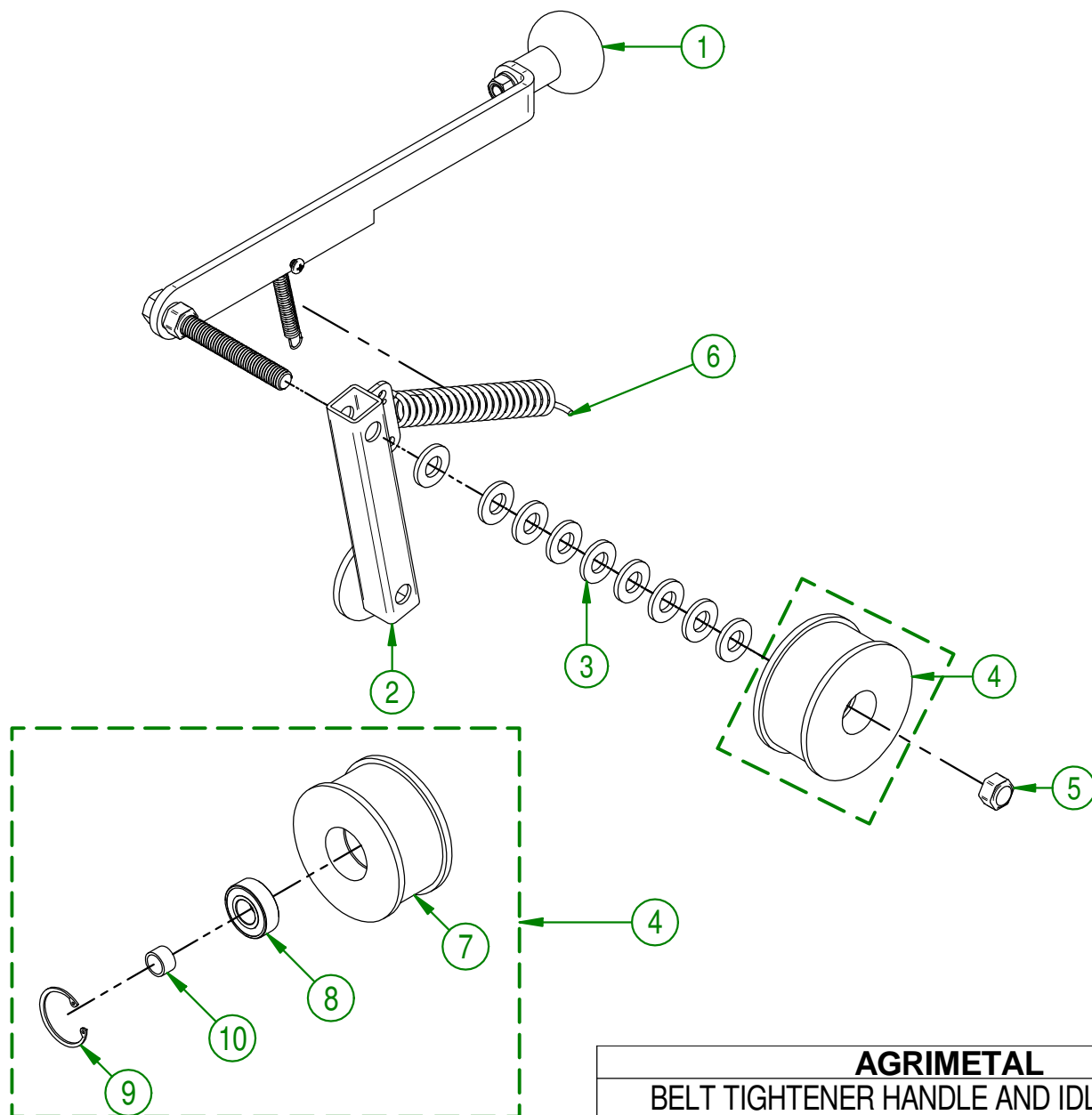

<b>AGRIMETAL</b>	
<b>BELT TIGHTENER HANDLE AND IDLER ASSY.</b>	
CREATION : 06/12/16	ASSEMBLY : <b>23-57-0125</b>
REVISION : 26/10/18	AUTHOR : J.KABWE   Page 11 de 43

#	PART #	Qty	TITLE
1	23-04-0200	1	BELT TIGHTENER HANDLE
2	NC17-46-0018	1	HANDLE KNOB
3	NC01-17-0119	1	HEX. BOLT GR2 ZINC 3/8-16 X 2 1/4"
4	NC02-32-0012	2	LOCK WASHER ZINC 3/8"
5	NC02-07-0018	1	HEX. NUT ZINC 3/8-16
6	NC01-15-0259	1	HEX. BOLT GR2 ZINC 3/8-16 X 2 1/4"
7	NC01-96-0014	1	NYLON-INSERT LOCKNUT ZINC 1/2-13
8	NC02-40-0083	1	MÉCA.SCREW T. ROUND . SQUARE 10-24 X 1 OR 3/16 X 1
9	NC13-85-0030	1	OUTSIDE SPRING .043" WIRE X .375 OD X 2" LENGTH. 30 COIL TOTAL
10	NC01-96-0006	1	NYLON NUT ZINC 10-24

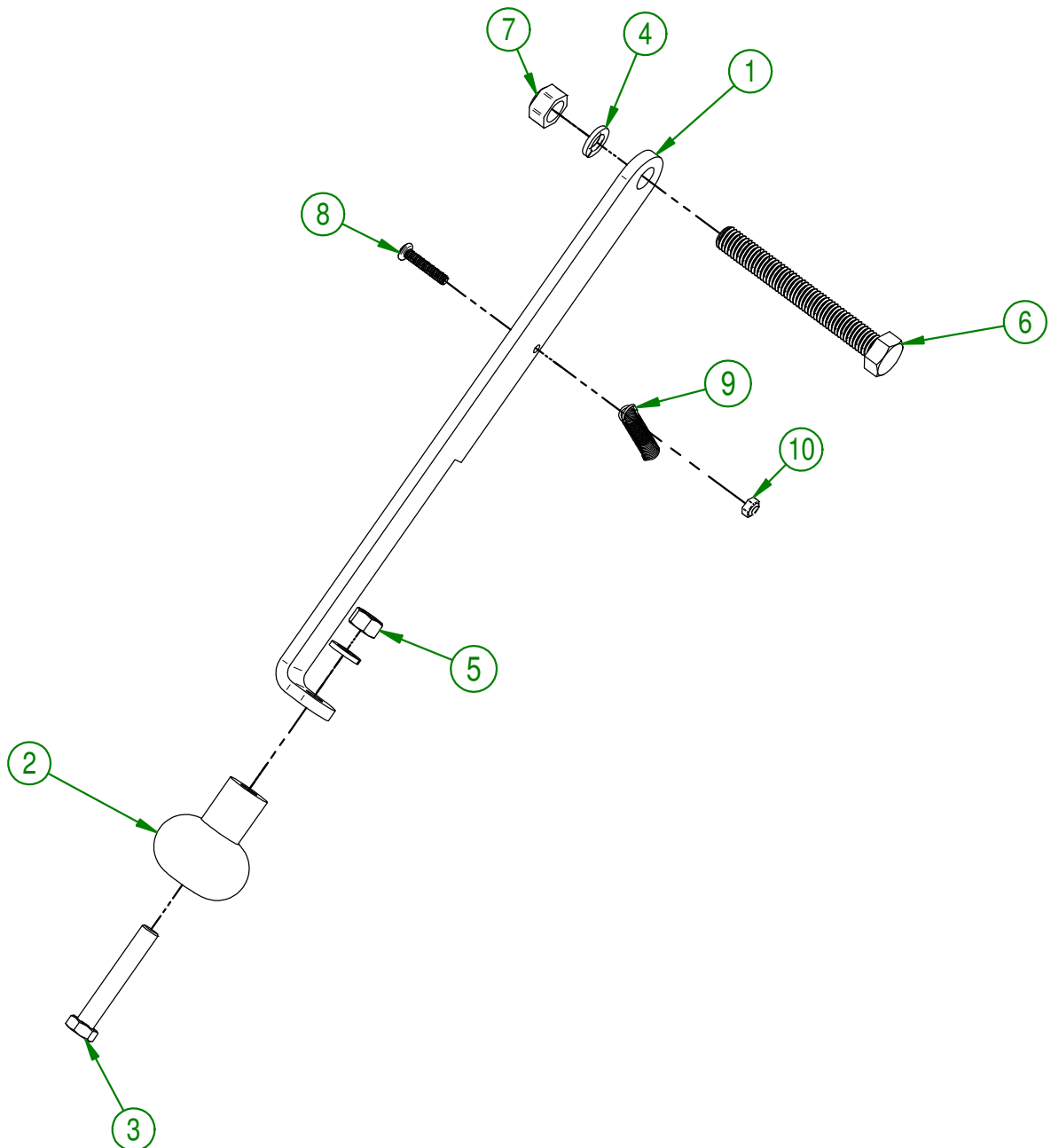

<b>AGRIMETAL</b>	
<b>BELT TIGHTENER HANDLE ASSY.</b>	
CREATION : 06/12/16	ASSEMBLY : <b>23-55-0065</b>
REVISION : 10/01/18	AUTHOR : J.KABWE   Page 12 de 43

#	PART #	Qty	TITLE
1	23-42-0110	1	BELT TENDER HANDLE COUVER
2	23-42-0115	1	BELT TENDER HANDLE GUIDE
3	NC01-17-0008	2	HEX. BOLT GR2 ZINC 1/4-20 X 1 1/2"
4	NC02-25-0007	2	WASHER ZINC 0.281 = 9/32
5	NC01-96-0009	2	NYLON-INSERT LOCKNUT ZINC 1/4-20

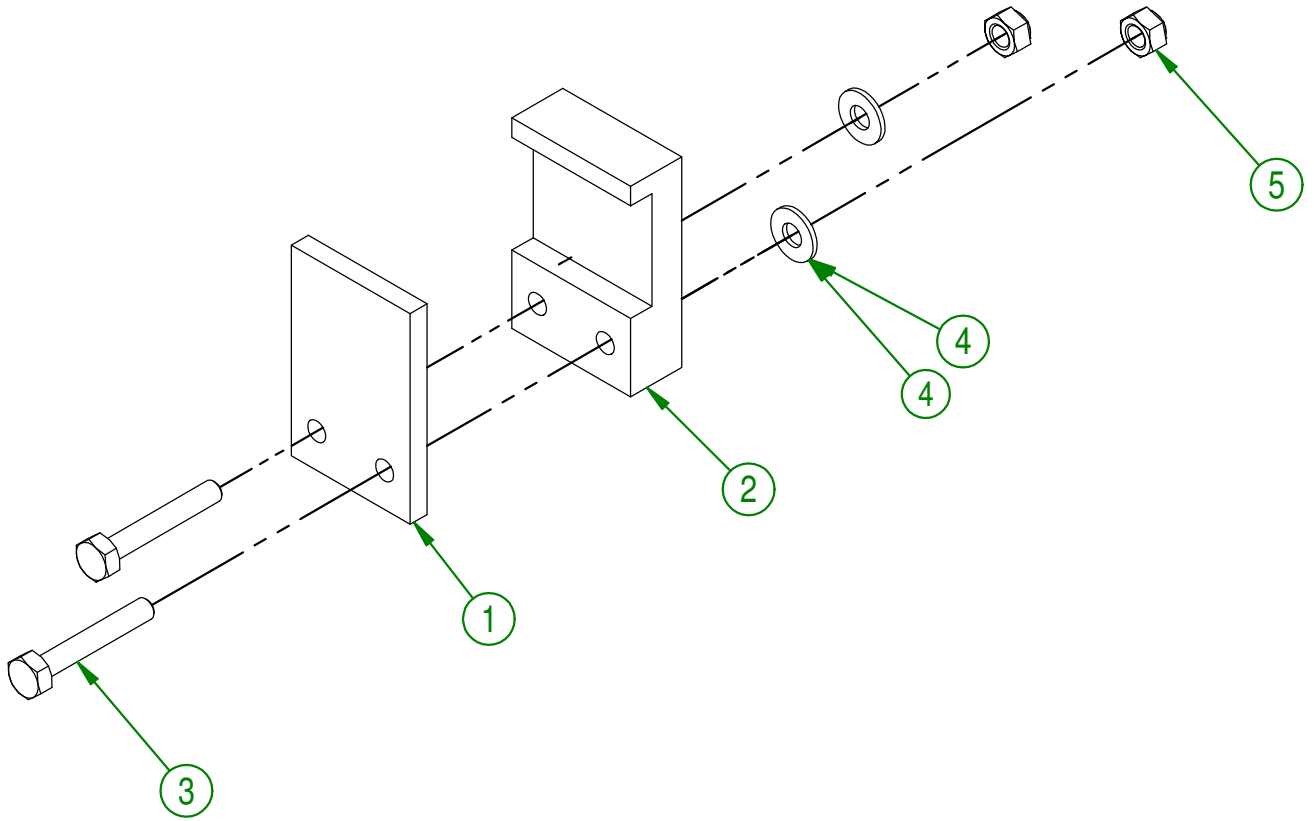

<b>AGRIMETAL</b>	
<b>BELT TIGHTENER HANDLE GUIDE ASSY</b>	
CREATION : 06/12/16	ASSEMBLY : <b>23-57-0135</b>
REVISION : 10/01/18	AUTHOR : J.KABWE   Page 13 de 43

#	PART #	Qty	TITLE
1	21-01-0950	8	FLAT WASHER 10GA 1.005" DIA X 25/64"
2	NC01-17-0119	4	HEX. BOLT GR2 ZINC 3/8-16 X 2 1/4"
3	NC13-15-0059	4	YELLOW RUBBER BASE MOUNT
4	NC13-15-0059	4	YELLOW RUBBER BASE MOUNT
5	26-03-4800	8	WASHER
6	NC01-96-0011	4	NYLON NUT 3/8-16

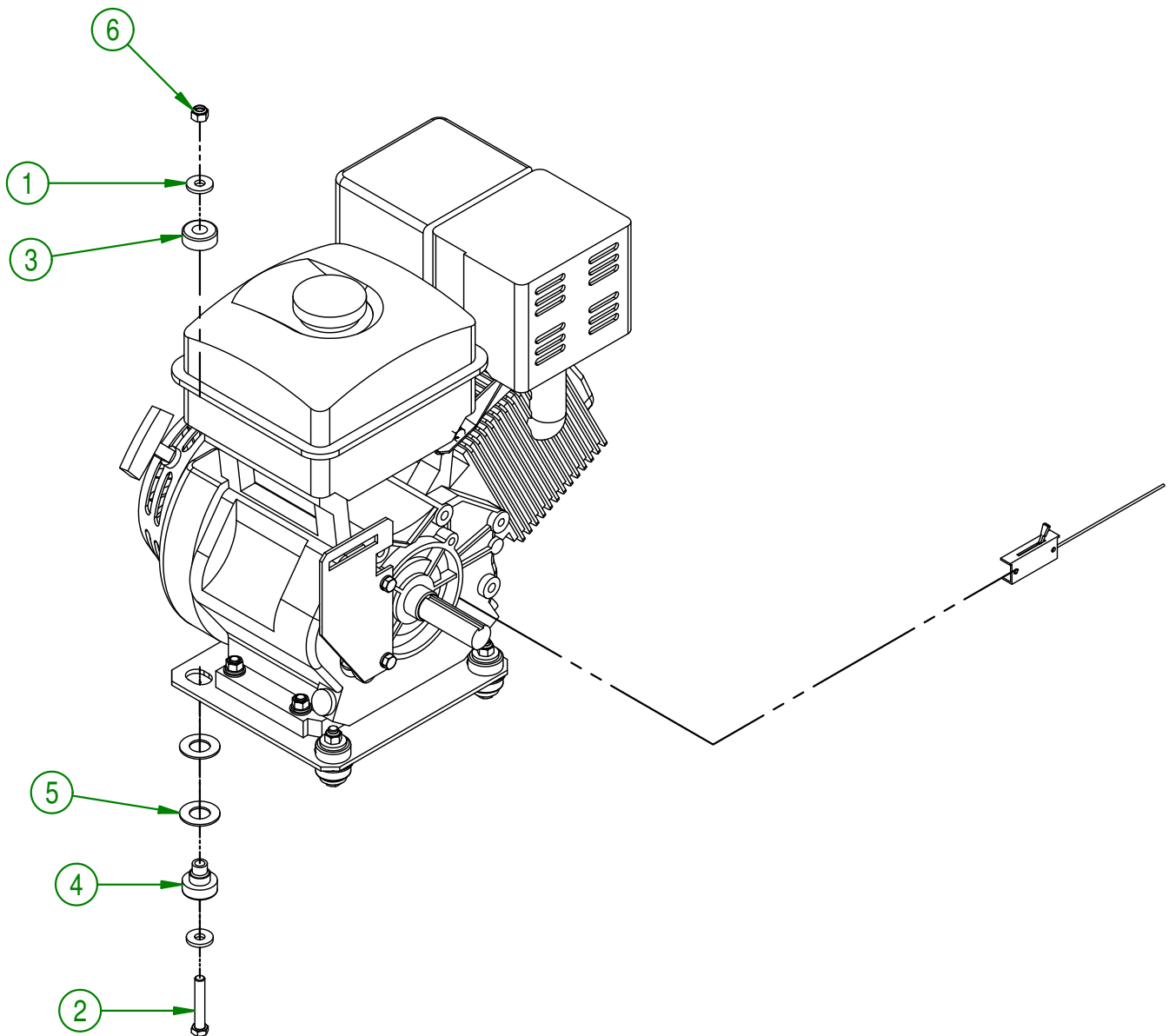

<b>AGRIMETAL</b>	
<b>9HP MANUAL HONDA ENGINE GROUP.</b>	
CREATION : 06/12/16	ASSEMBLY : <b>23-57-1045</b>
REVISION : 30/08/19	AUTHOR : J.KABWE   Page 14 de 43



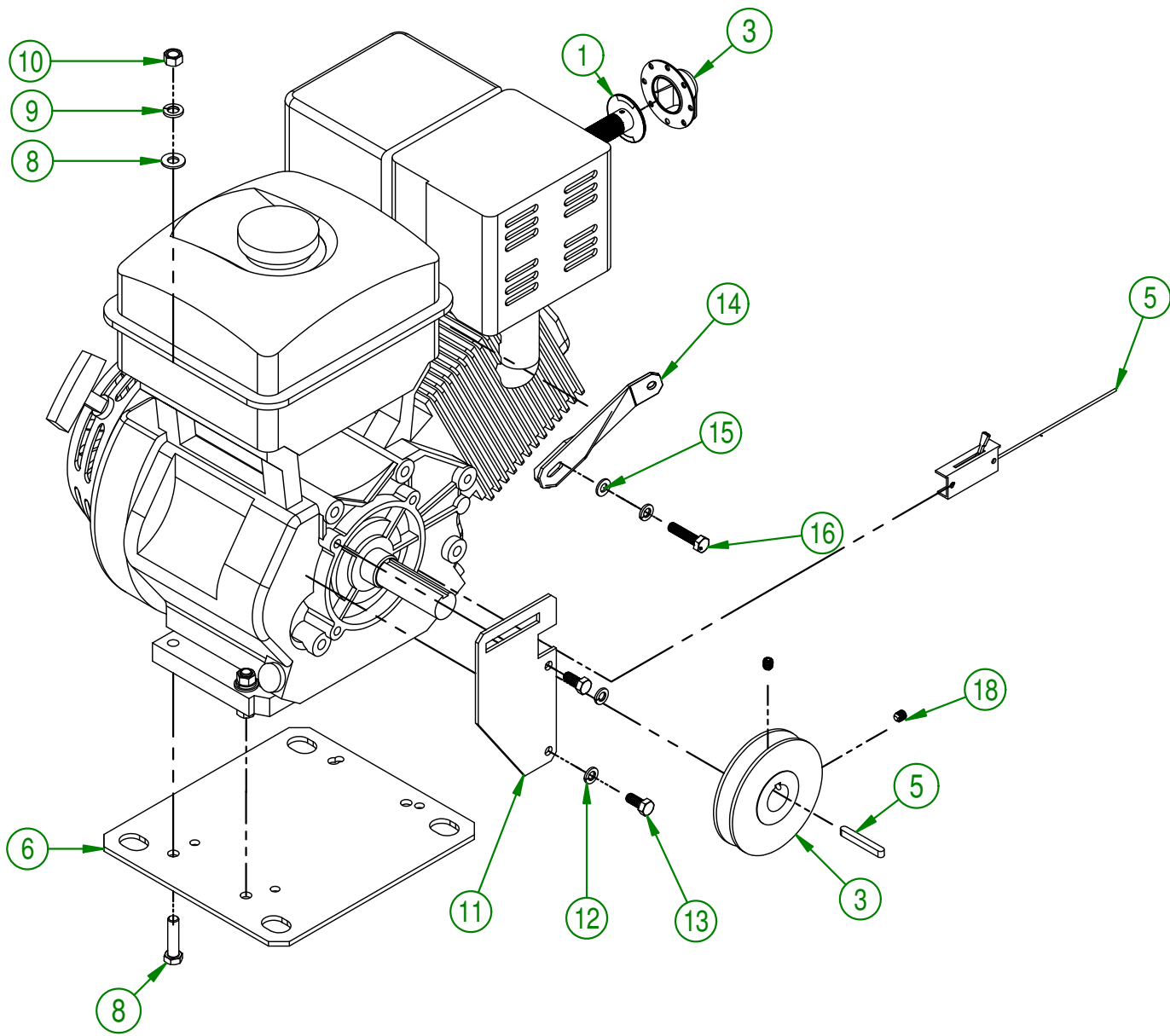

<b>AGRIMETAL</b>	
<b>9HP MANUAL HONDA ENGINE ASSY</b>	
CREATION : 06/12/16	ASSEMBLY : <b>23-55-1045</b>
REVISION : 30/08/19	AUTHOR : J.KABWE   Page 15 de 43

#	PART #	Qty	TITLE
1	NC13-37-0519	1	18355-ZE2-010 ARRESTER SPARK
2	NC13-37-0019	1	18331-ZE2-810 MUFFLER DEFLECTOR
3	23-39-0060	1	MB40 X Ø1" PULLEY X KW 1/4" 2SS 5/16"-18 TL
4	01-41-0920	1	1/4" X 1/4" X 2" TL KEY
5	NC13-37-0581	1	41" SHEATH THROTTLE CONTROL
6	23-04-0110	1	ENGINE BASE
7	NC01-17-0116	4	HEX. BOLT GR2 ZINC 3/8-16 X 1 1/2"
8	01-01-2485	4	FLAT WASHER 14 GA X 13/16"OD X 25/64" ID
9	NC02-32-0012	4	LOCK WASHER ZINC 3/8"
10	NC02-07-0018	4	HEX. NUT ZINC 3/8-16
11	23-01-1060	1	BELT TENDER SUPPORT
12	NC02-32-0011	3	LOCK WASHER ZINC 5/16"
13	NC01-21-0058	2	HEX. BOLT GR2 NF ZINS 5/16-24 X 3/4
14	01-03-5405	1	EXHAUST SUPPORT
15	NC02-22-0008	1	WASHER ZINC 5/16"
16	NC01-45-0188	1	BOLT MET.GR2 NF ZINC 8MM X 35MM
17	NC02-44-0103	2	SET SCREW 5/16-18 X 3/8"

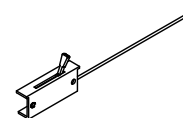
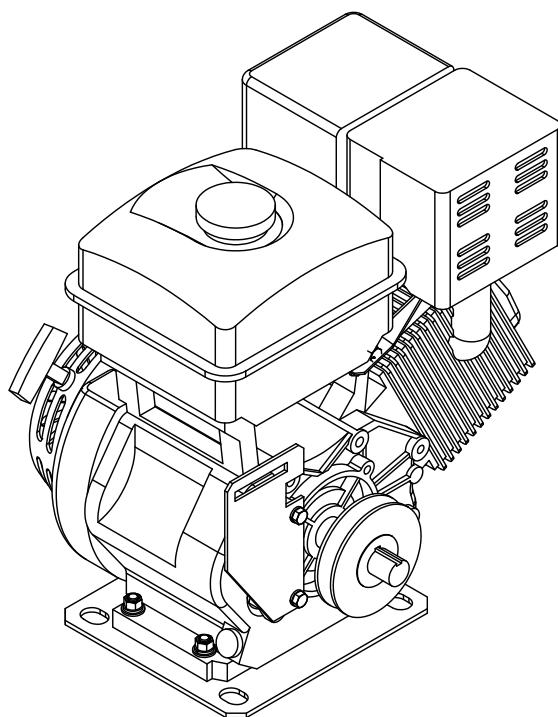

<b>AGRIMETAL</b>	
<b>9HP MANUAL HONDA ENGINE ASSY</b>	
CREATION : 06/12/16	ASSEMBLY : <b>23-55-1045</b>
REVISION : 30/08/19	AUTHOR : J.KABWE   Page 16 de 43

#	PART #	Qty	TITLE
1	23-13-1025	1	DRIVE SHAFT
2	NC14-55-0169	1	COUPLING SPROCKET 4016 X 3/4"Ø KW 3/16 2SS5/16-18
3	NC14-55-0154	1	COUPLING SPROCKET 4016 X 1"Ø KW1/4 2SS5/16-18
4	NC14-20-0030	1	CHAIN 4016
5	NC02-44-0103	2	SET SCREW 5/16-18 X 3/8"
6	NC01-65-0096	2	ROUND END KEY 3/16 X 3/16 XI 1/2"
7	NC14-75-0031	2	PILLOW BLOCKS UCP204-12 3/4" Ø (CNINE)
8	NC02-25-0011	8	WASHER SAE ZINC 17/32 ID
9	NC01-17-0250	4	HEX. BOLT GR2 ZINC 1/2-13 X 1 3/4"
10	NC02-32-0014	4	LOCK WASHER ZINC 1/2"
11	NC02-07-0020	4	HEX. NUT ZINC 1/2-13
12	23-39-0120	1	PULLEY 2MA-40 DIA. 3/4"
13	NC14-25-1529	2	V BELT 1/2 COGDED RAW EDGE AX-51 GATES

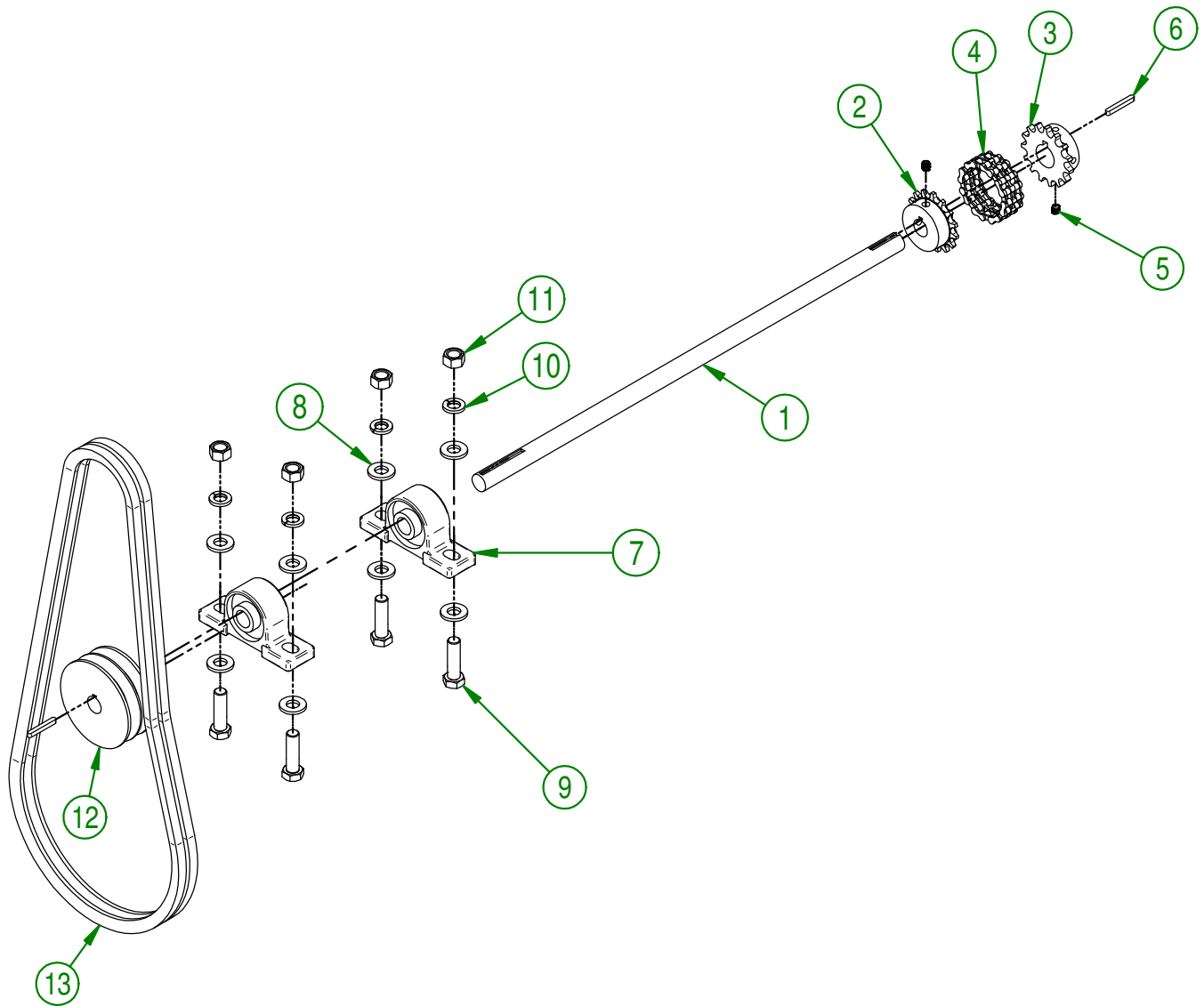

<b>AGRIMETAL</b>	
<b>DRIVE SHAFT ASSY</b>	
CREATION : 06/12/16	ASSEMBLY : <b>23-57-1065</b>
REVISION : 10/10/18	AUTHOR : J.KABWE   Page 17 de 43

23-57-0175

#	PART #	Qty	TITLE
1	23-50-0025	1	FRAME
2	NC01-04-0055	6	CARR. BOLT GR2 ZINC 5/16-18 X 5/8"
3	NC02-14-0006	6	HEX. NUT SPECIAL FLANGET NC 5/16-18 B GRADE
4	01-01-2485	12	FLAT WASHER
5	NC01-17-0122	6	HEX. BOLT GR2 ZINC 3/8-16 X 3"
6	NC02-32-0012	6	LOCK WASHER ZINC 3/8"
7	NC02-07-0018	6	HEX. NUT ZINC 3/8-16

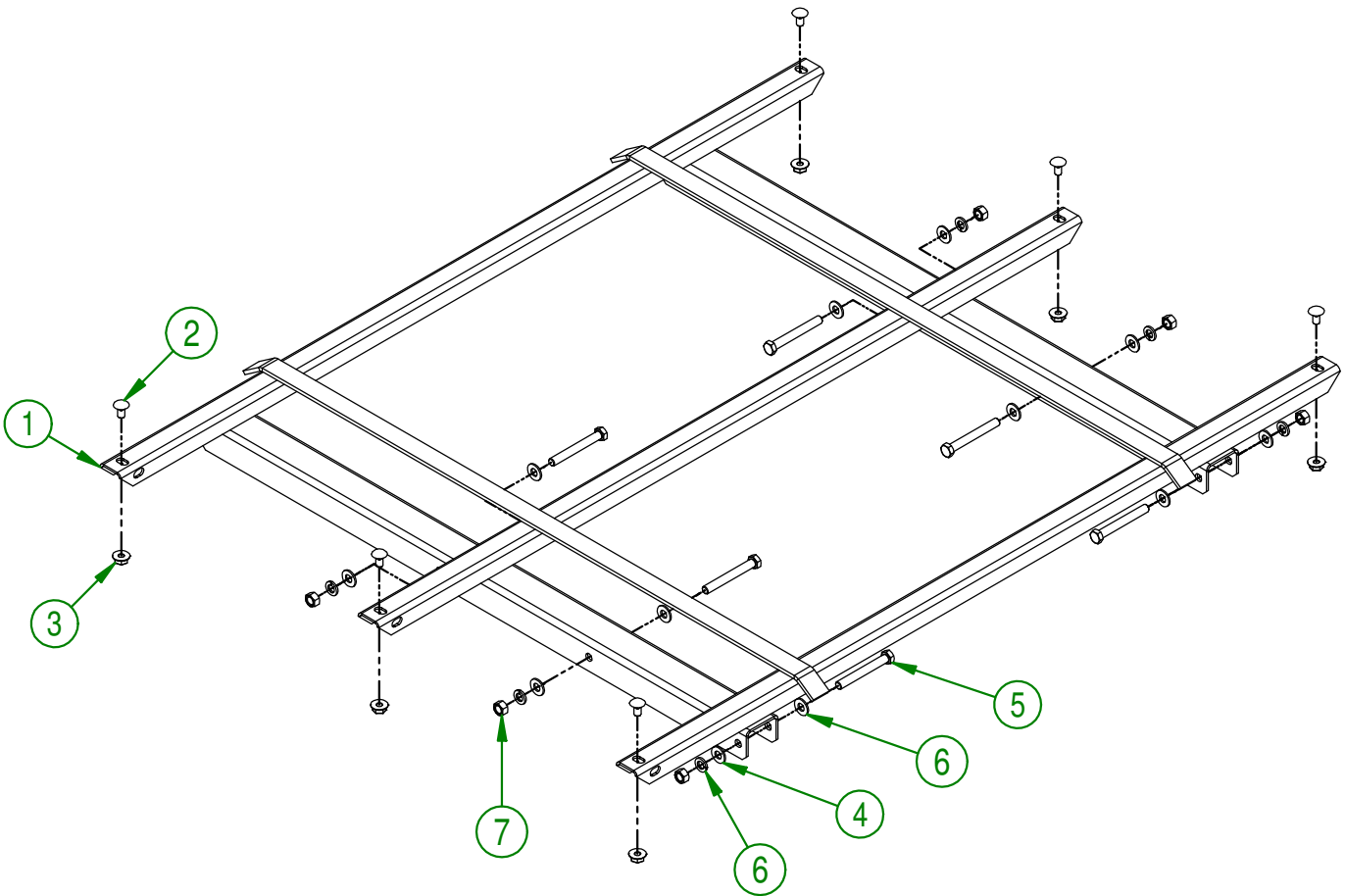

**AGRIMETAL**  
FRAME GROUP.

CREATION : 06/12/16  
REVISION : 01/02/18

ASSEMBLY : **23-57-0175**

AUTHOR : J.KABWE | Page 18 de 43

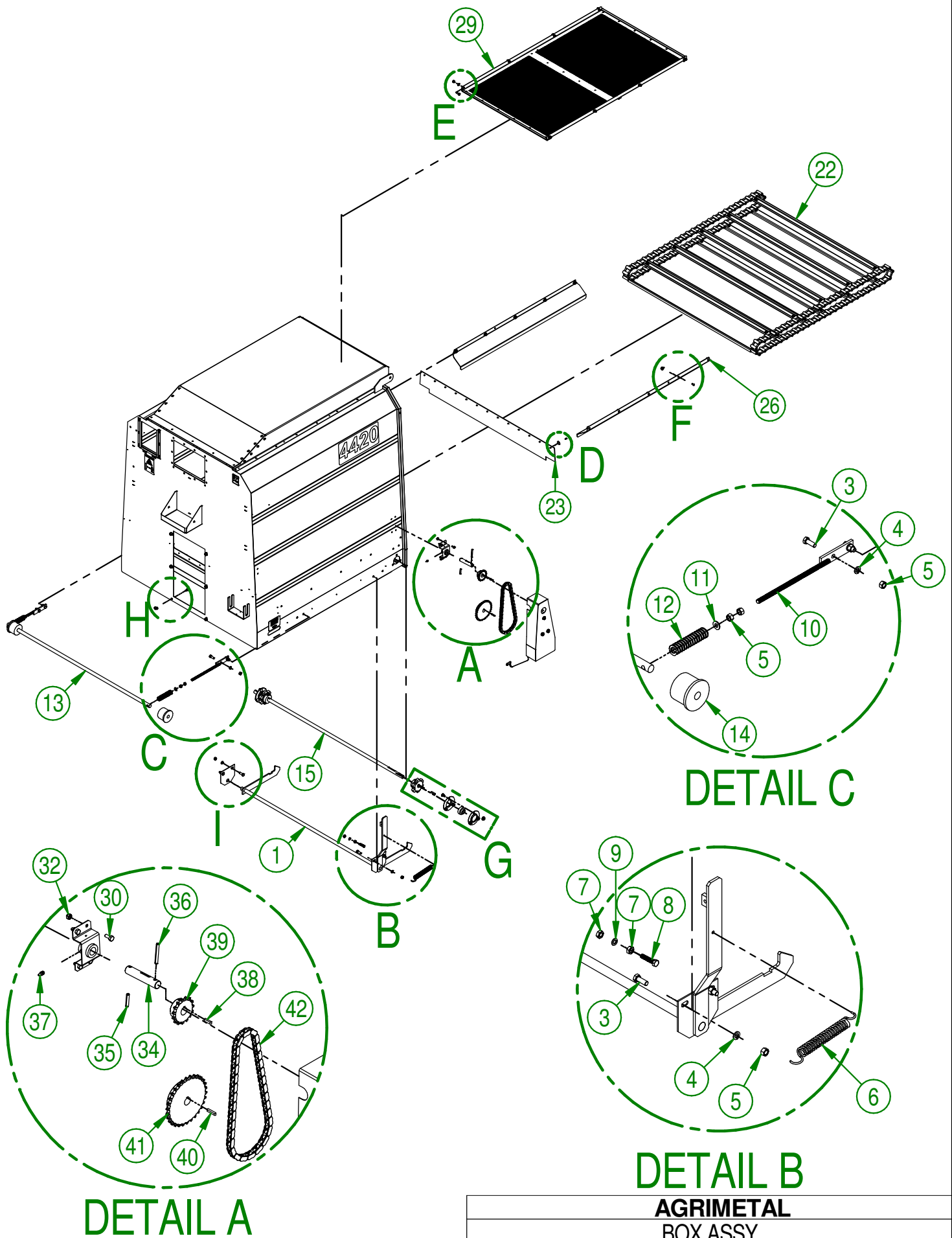

**DETAIL A**

**DETAIL C**

**DETAIL B**

<b>AGRIMETAL</b>	
<b>BOX ASSY.</b>	
CREATION : 07/09/21	ASSEMBLY : <b>23-57-1007</b>
REVISION : 07/09/21	AUTHOR : J.KABWE

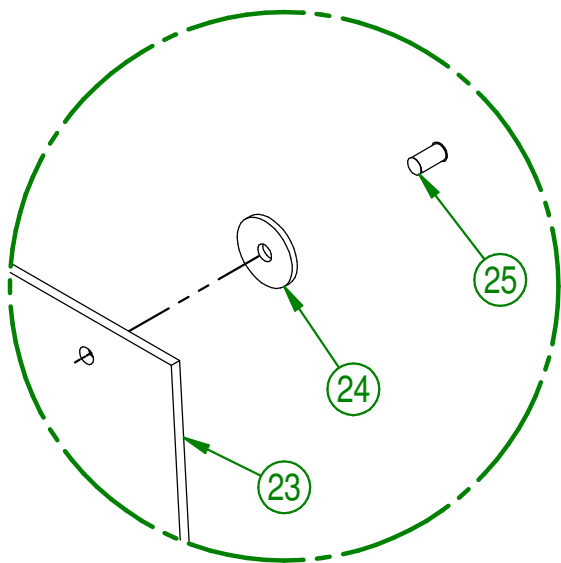

DETAIL D

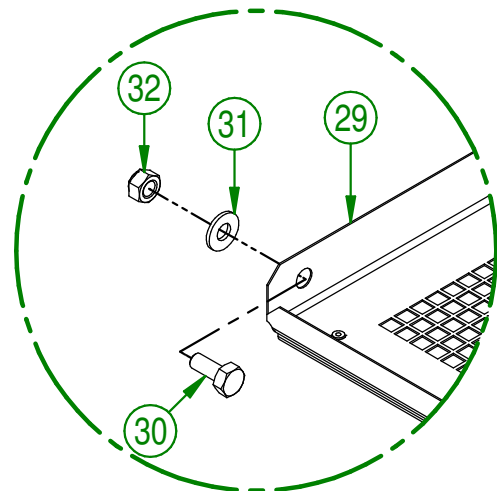

DETAIL E

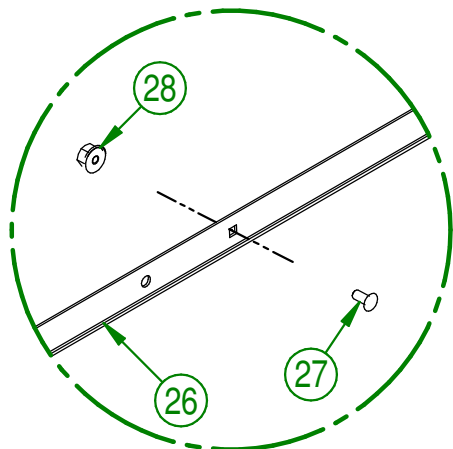

DETAIL F

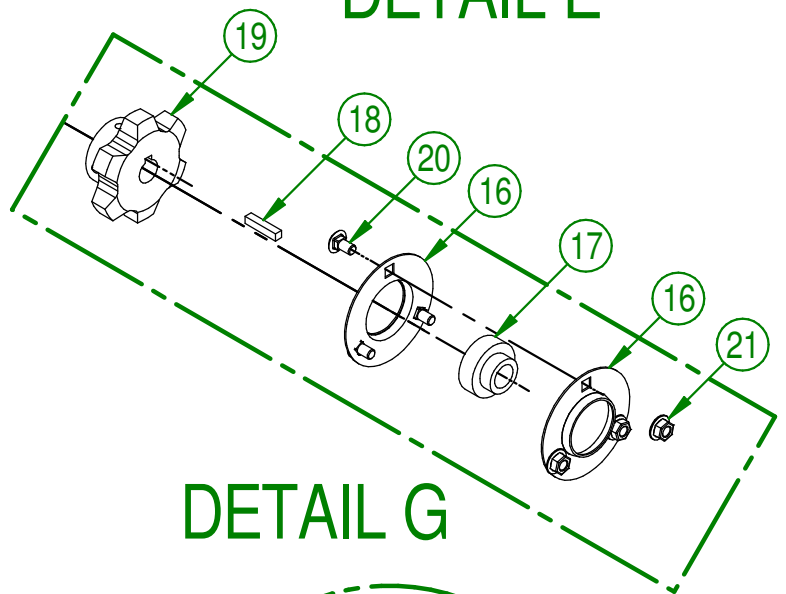

DETAIL G

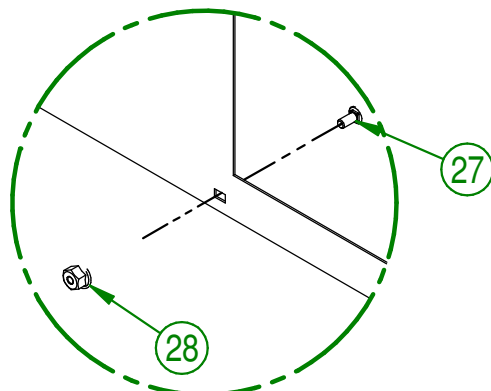

DETAIL H

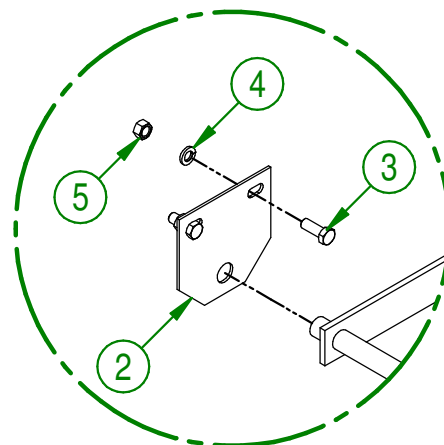

DETAIL I

<b>AGRIMETAL</b>	
<b>BOX ASSY.</b>	
CREATION : 07/09/21	ASSEMBLY : <b>23-57-1007</b>
REVISION : 07/09/21	AUTHOR : J.KABWE

23-57-1007

#	PART #	Qty	TITLE
1	23-50-1055	1	DOOR LATCH
2	23-01-7610	1	DOOR PIVOT STOPER
3	NC01-17-0114	8	HEX. BOLT GR2 ZINC 3/8-16 X 1"
4	NC02-32-0012	8	LOCK WASHER ZINC 3/8"
5	NC02-07-0018	12	HEX. NUT ZINC 3/8-16
6	NC13-85-0008	1	GALVANISED SPRING
7	NC02-07-0017	2	HEX. NUT 5/16-18
8	NC01-17-0062	1	HEX. BOLT GR2 ZINC 5/16-18 X 1 1/2" TOTAL LENGTH
9	NC02-32-0011	1	LOCK WASHER ZINC 5/16"
10	23-50-0080	2	CONVEYOR CHAIN TIGHTNER
11	01-01-2485	2	FLAT WASHER 14 GA X 13/16"OD X 25/64" ID
12	NC13-86-0050	2	SPRING 1/2" ID X 1" OD X 4" LG
13	23-13-1005	1	IDLER SHAFT
14	23-42-0105	2	PLASTIC IDLER ROLLER
15	23-13-1035	1	CONVEYOR DRIVE SHAFT
16	NC14-75-0008	4	STEEL BEARING ONLY 3 HOLES F4 3 9/16" OD
17	NC14-75-0014	2	STEEL BEARING SB 204-12 X 3/4" ID
18	01-41-0910	2	KEY
19	23-43-0000	2	CAST IRON PINION 62 B HOLE 3/4 KW 1/4 2 SS
20	NC01-04-0055	6	CARR. BOLT GR2 ZINC 5/16-18 X 5/8"
21	NC02-14-0006	6	HEX. NUT SPECIAL FLANGET NC 5/16-18 B GRADE
22	23-55-0010	1	CHAIN #62 AND U PADDLE ASSY.
23	NC13-15-0065	1	BLACK RUBBER SN60 1/8" X 4 3/4" X 43 7/8" TL
24	16-01-2720	13	WASHER 13/16" DIA. X 13/64"
25	NC01-78-0016	13	ALUMINIUM BLIND POP RIVET STEEL MANDREL 0.187 X 0.690
26	23-01-2645	2	CONVEYOR DEFLECTOR
27	NC01-04-0001	16	CARR. BOLT GR2 ZINC 1/4-20 X 1/2"
28	NC02-14-0017	16	FLANGED NUT GR. B 1/4-20
29	23-55-0025	1	EXHAUST SCREEN ( 1/4")
30	NC01-17-0003	12	HEX. BOLT GR2 ZINC 1/4-20 X 5/8"
31	NC02-25-0007	8	WASHER ZINC 0.281 = 9/32
32	NC01-96-0009	12	NYLON-INSERT LOCKNUT ZINC 1/4-20
33	23-50-1040	1	CRANK SHAFT SUPPORT
34	23-13-1030	1	CRANK SHAFT
35	NC01-69-0459	1	ZINC SPRING PIN TENDER DIA. 1/4" X 1 1/4"
36	NC01-69-0465	1	ZINC SPRING PIN TENDER DIA. 1/4" X 2" TL
37	NC01-69-0785	1	STRAIGHT GREASE FITTING 1/4-28
38	NC01-65-0094	1	ROUND END KEY 3/16" X 3/16" X 7/8" TL
39	NC14-55-0234	1	SPROCKET 40B15H X 3/4" KW 3/16", 2SS 5/16-18
40	NC01-65-0089	1	ROUND END KEY 3/16" X 3/16" X 1 1/16" TL
41	NC14-55-0235	1	SPROCKET 40B30H X DIA. 3/4", KW 3/16". 2SS 5/16-18
42	23-37-1005	1	CHAIN # 40 X 30 3/4" TL + MANUAL DECK CONVEYOR 1/2 MESH

**AGRIMETAL**  
**BOX ASSY.**

CREATION : 07/09/21  
REVISION : 07/09/21

ASSEMBLY : **23-57-1007**  
AUTHOR : J.KABWE



23-55-0010

#	PART #	Qty	TITLE
1	23-01-3320	11	CONVEYOR PADDLE
2	NC01-37-0003	22	HEX. BOLT GR8 1/4-28 X 5/8"
3	23-37-0190	1	CHAIN # 62 (53 LINK ) (PAIR)
4	NC01-97-0004	22	NYLON-INSERT LOCKNUT ZINC 1/4-28

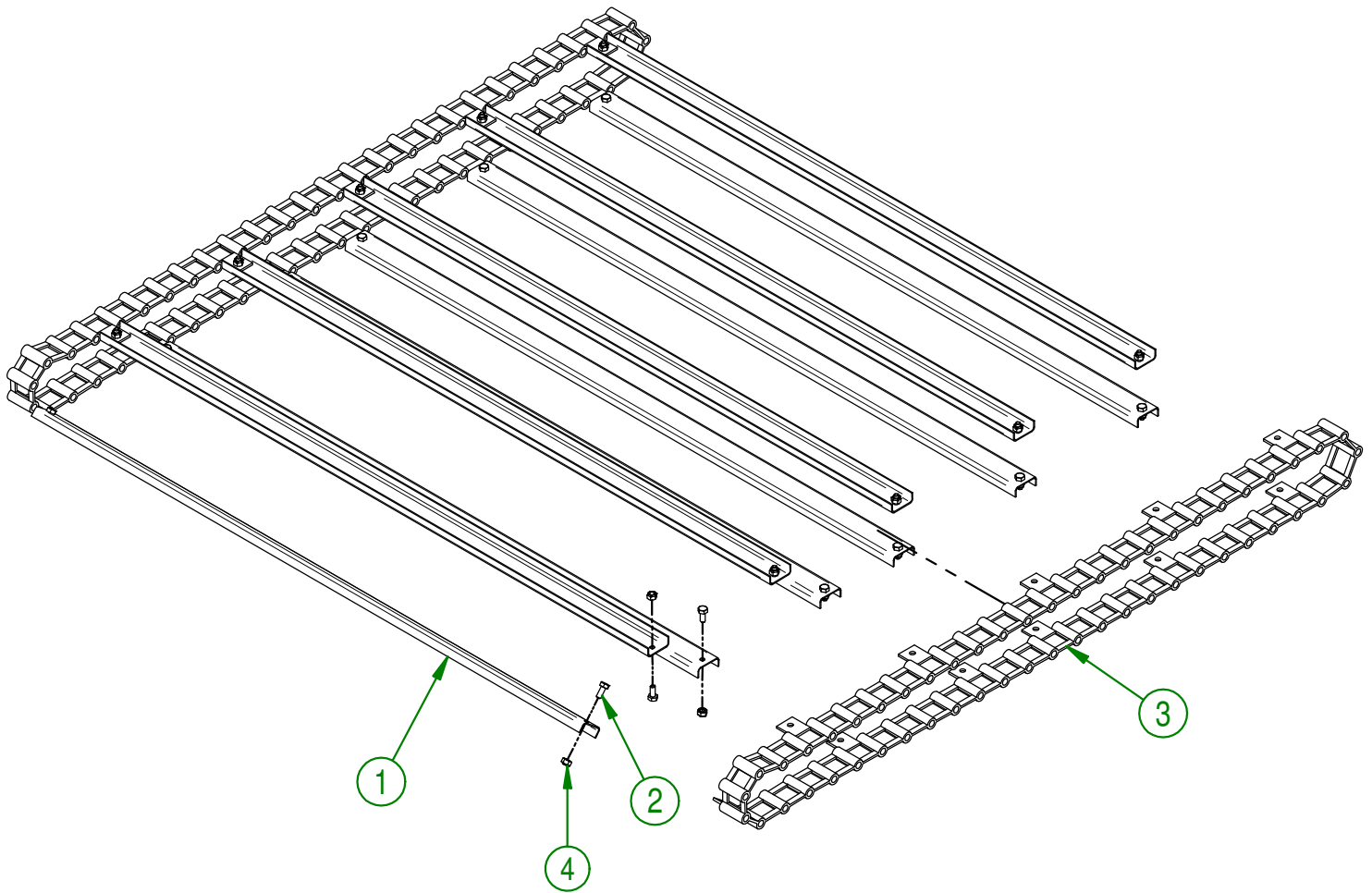

<b>AGRIMETAL</b>	
<b>CHAIN #62 AND U PADDLE ASSY.</b>	
CREATION : 07/12/16	ASSEMBLY : <b>23-55-0010</b>
REVISION : 10/01/18	AUTHOR : J.KABWE   Page 22 de 43

#	PART #	Qty	TITLE
1	23-03-1830	1	EXHAUST
2	23-03-1835	3	EXHAUST REINFORCING
3	NC01-78-0055	18	ALUMINIUM BLIND POP RIVET STEEL MANDREL 0.125 X 0.515

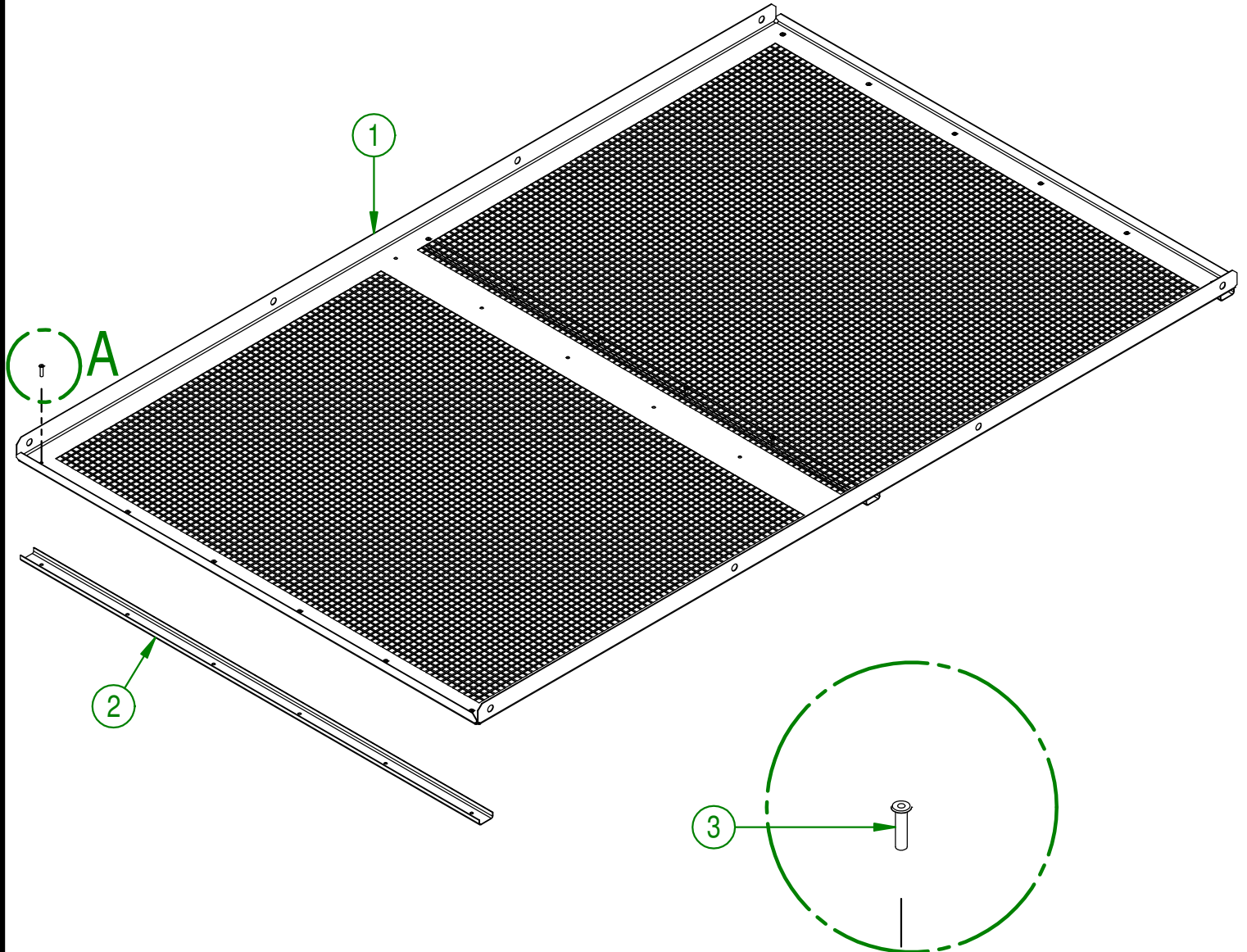

**DETAIL A**

<b>AGRIMETAL</b>	
EXHAUST SCREEN ( 1/4" )	
CREATION : 04/08/17	ASSEMBLY : <b>23-55-0025</b>
REVISION : 10/01/18	AUTHOR : J.KABWE   Page 23 de 43

#	PART #	Qty	TITLE
1	23-50-1045	1	MANUAL CONVEYOR CHAIN GUARD SUPPORT
2	NC01-17-0002	2	HEX. BOLT GR2 ZINC 1/4-20 X 1/2"
3	NC01-96-0009	2	NYLON-INSERT LOCKNUT ZINC 1/4-20

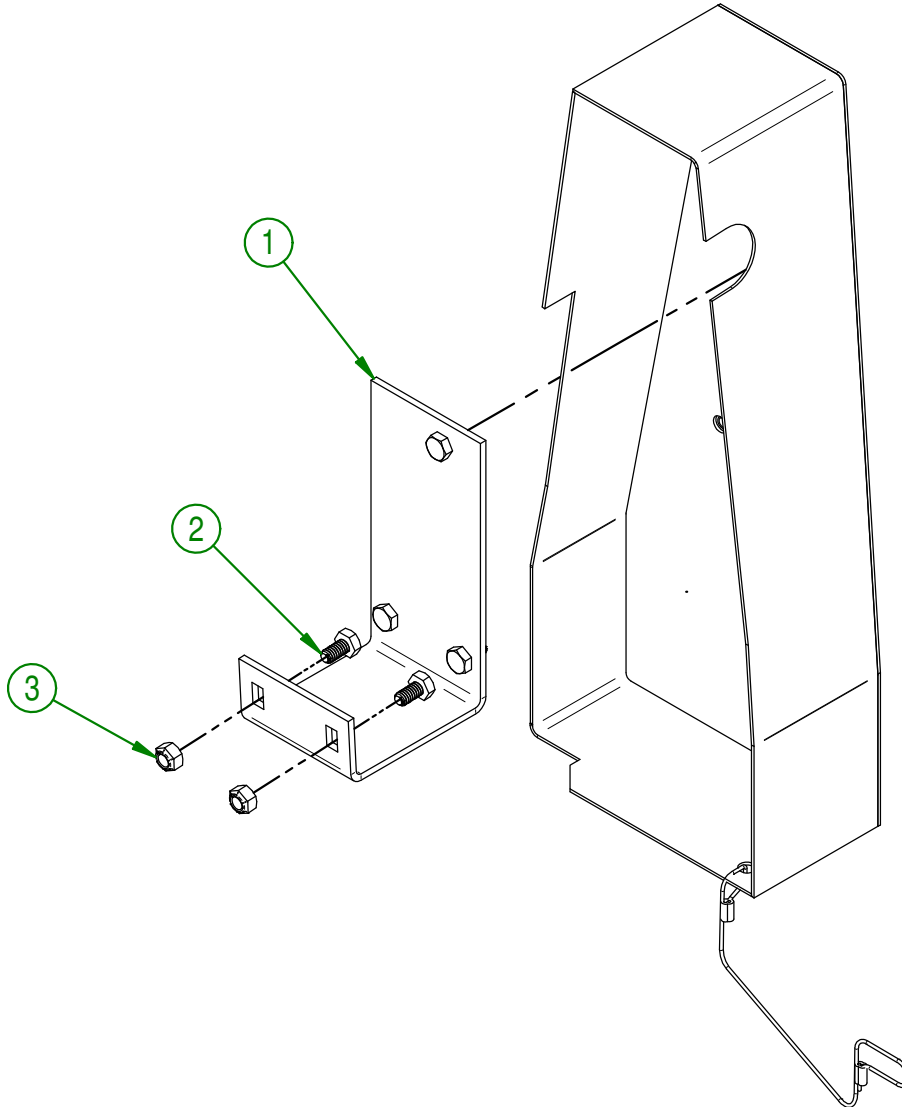

<b>AGRIMETAL</b>	
<b>CRANK CONVEYOR CHAIN GUARD AND SUPPORT ASSY</b>	
CREATION : 08/12/16	ASSEMBLY : <b>23-57-1085</b>
REVISION : 10/01/18	AUTHOR : J.KABWE   Page 24 de 43

#	PART #	Qty	TITLE
1	23-50-1080	1	MANUAL CONVEYOR CHAIN GUARD
2	NC02-14-0017	3	FLANGED NUT GR. B 1/4-20
3	23-41-0137	1	STEEL WIRE CONVEYOR PROTECTION DIA. 1/16" X 15" TL
4	NC01-64-0005	2	OVAL SLEEVE (ALUMINUM)

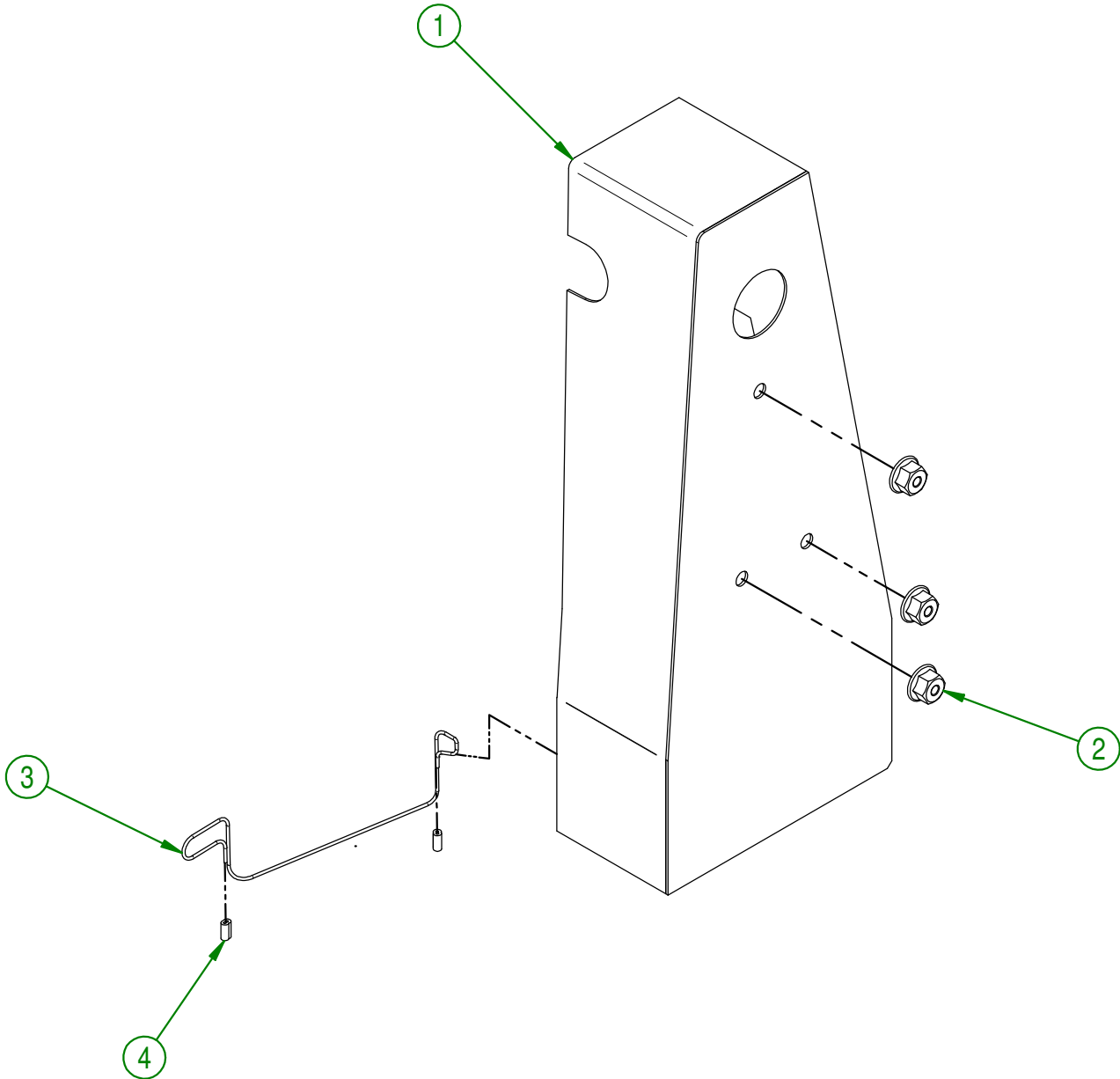

<b>AGRIMETAL</b>	
<b>MANUAL CONVEYOR CHAIN GUARD ASSY.</b>	
CREATION : 08/12/16	ASSEMBLY : <b>23-57-1090</b>
REVISION : 10/01/18	AUTHOR : J.KABWE   Page 25 de 43

#	PART #	Qty	TITLE
1	23-55-1090	1	BACK DOOR PRE ASS.
2	NC02-22-0013	6	WASHER ZINC 5/8 ID X 1 1/2 OD
3	NC01-17-0250	2	HEX. BOLT GR2 ZINC 1/2-13 X 1 3/4"
4	NC02-25-0011	4	WASHER SAE ZINC 17/32"
5	NC01-96-0014	2	NYLON-INSERT LOCKNUT ZINC 1/2-13
6	23-55-1110	2	GAS CYLINDER
7	01-09-0000	4	BEARING RACE (UCFL205-16)
8	01-01-2485	10	FLAT WASHER
9	NC01-17-0120	2	HEX.BOLT GR2 NC ZINC 3/8-16 X 2 1/2"
10	NC01-17-0121	2	HEX. BOLT GR2 ZINC 3/8-16 X 2 1/2"
11	NC01-96-0011	4	NYLON NUT 3/8-16

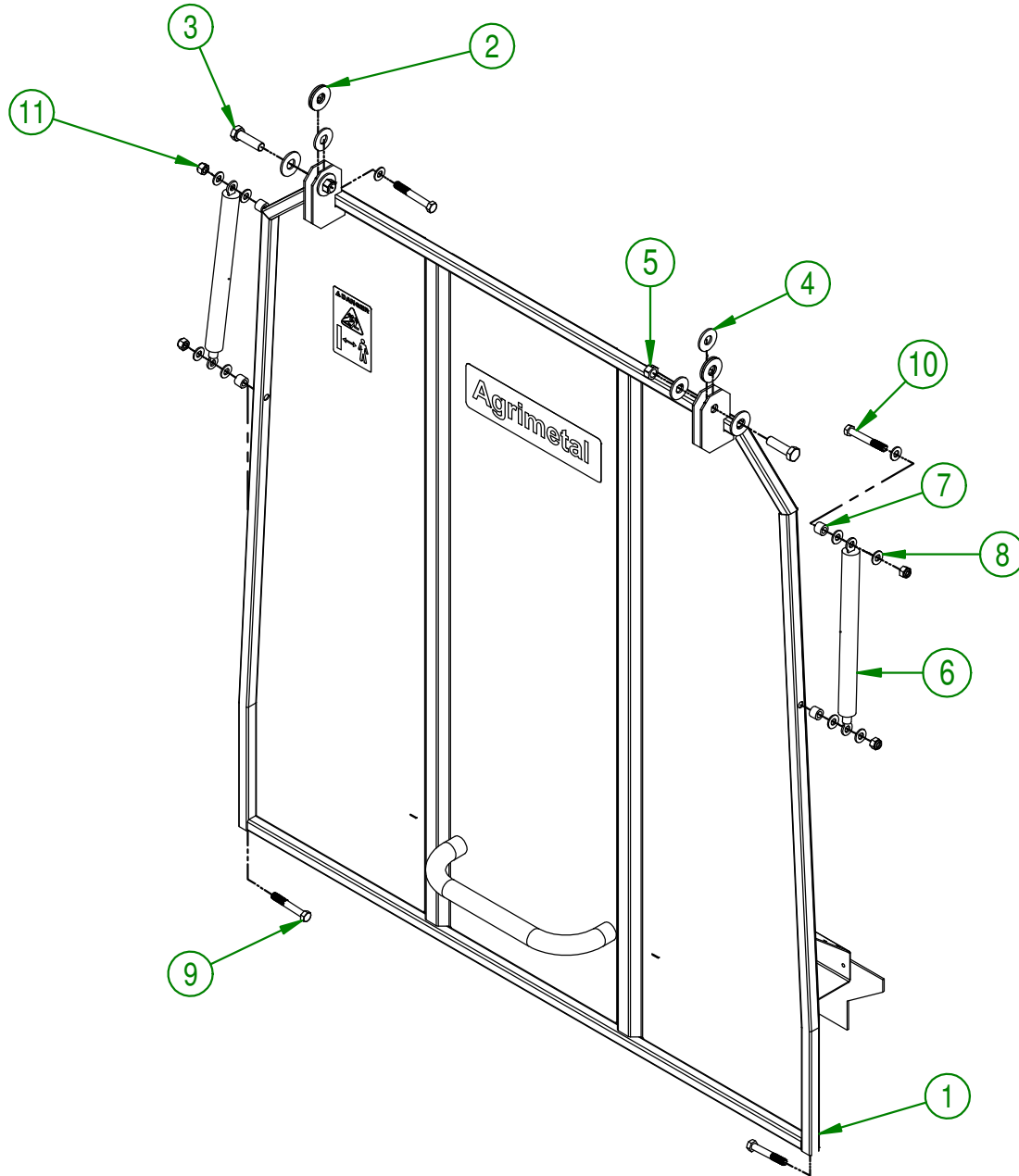

<b>AGRIMETAL</b>	
<b>BACK DOOR ASSY</b>	
CREATION : 06/12/16	ASSEMBLY : <b>23-57-1180</b>
REVISION : 02/02/18	AUTHOR : J.KABWE Page 26 de 43

#	PART #	Qty	TITLE
1	23-57-1185	1	BACK DOOR "STICKER INCLUDED"
2	23-42-0030	1	RUBBER BACK DOOR
3	NC01-78-0016	27	ALUMINIUM BLIND POP RIVET STEEL MANDREL 0.187 X 0.690
4	16-01-2720	27	WASHER 13/16" DIA. X 13/64"
5	NC13-15-0064	2	BLACK RUBBER SN60 1/8 THICK. X 3 1/2" X 10 1/2" +0-1/16

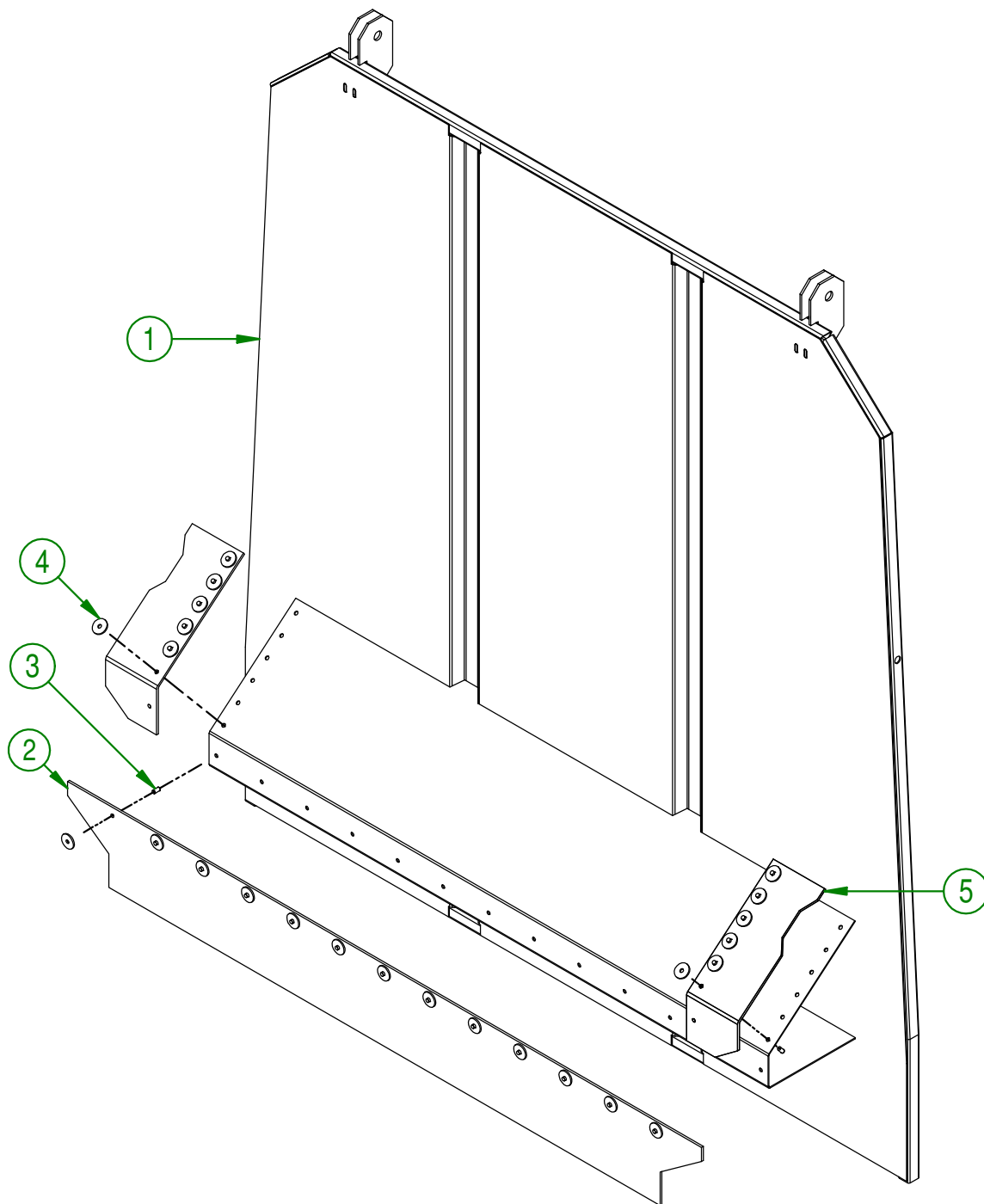

<b>AGRIMETAL</b>	
<b>BACK DOOR PRE ASS.</b>	
CREATION : 06/12/16	ASSEMBLY : <b>23-55-1090</b>
REVISION : 02/02/18	AUTHOR : J.KABWE Page 27 de 43

#	PART #	Qty	TITLE
1	23-50-1015	1	CHUT ELBOW 90°
2	23-22-2200	1	IMPELLER SPACER SIDE

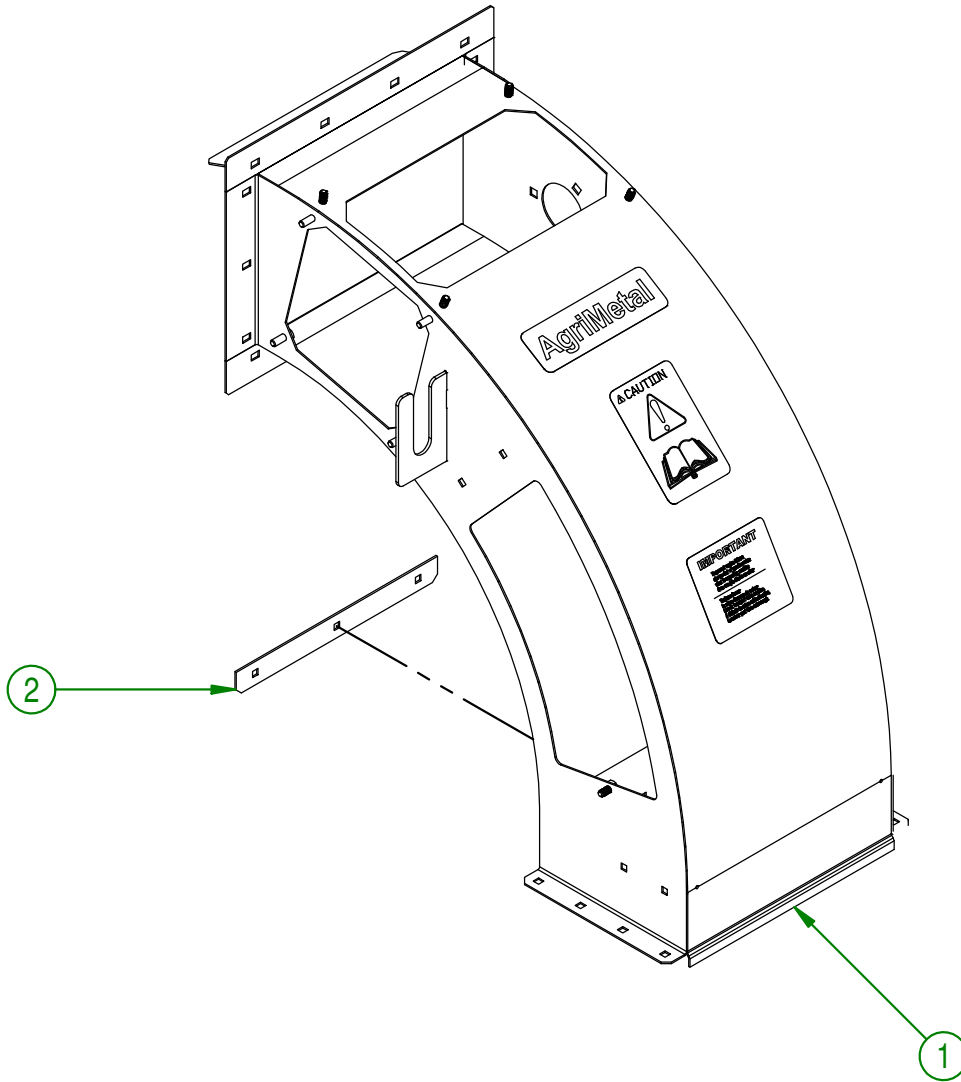

<b>AGRIMETAL</b>	
CHUT ELBOW 90° "STICKER INCLUDED"	
CREATION : 06/12/16	ASSEMBLY : <b>23-57-1190</b>
REVISION : 10/01/18	AUTHOR : J.KABWE   Page 28 de 43



#	PART #	Qty	TITLE
1	23-01-3107	1	HONDA ENGINE SHAFT GUARD (BOTTOM)
2	23-50-1067	1	HONDA ENGINE SHAFT GUARD
3	23-01-7660	1	GUARD BRAKET
4	NC01-04-0001	4	CARR. BOLT GR2 ZINC 1/4-20 X1/2"
5	NC02-14-0017	4	FLANGED NUT GR. B 1/4-20
6	NC02-25-0007	1	WASHER ZINC 0.281 = 9/32

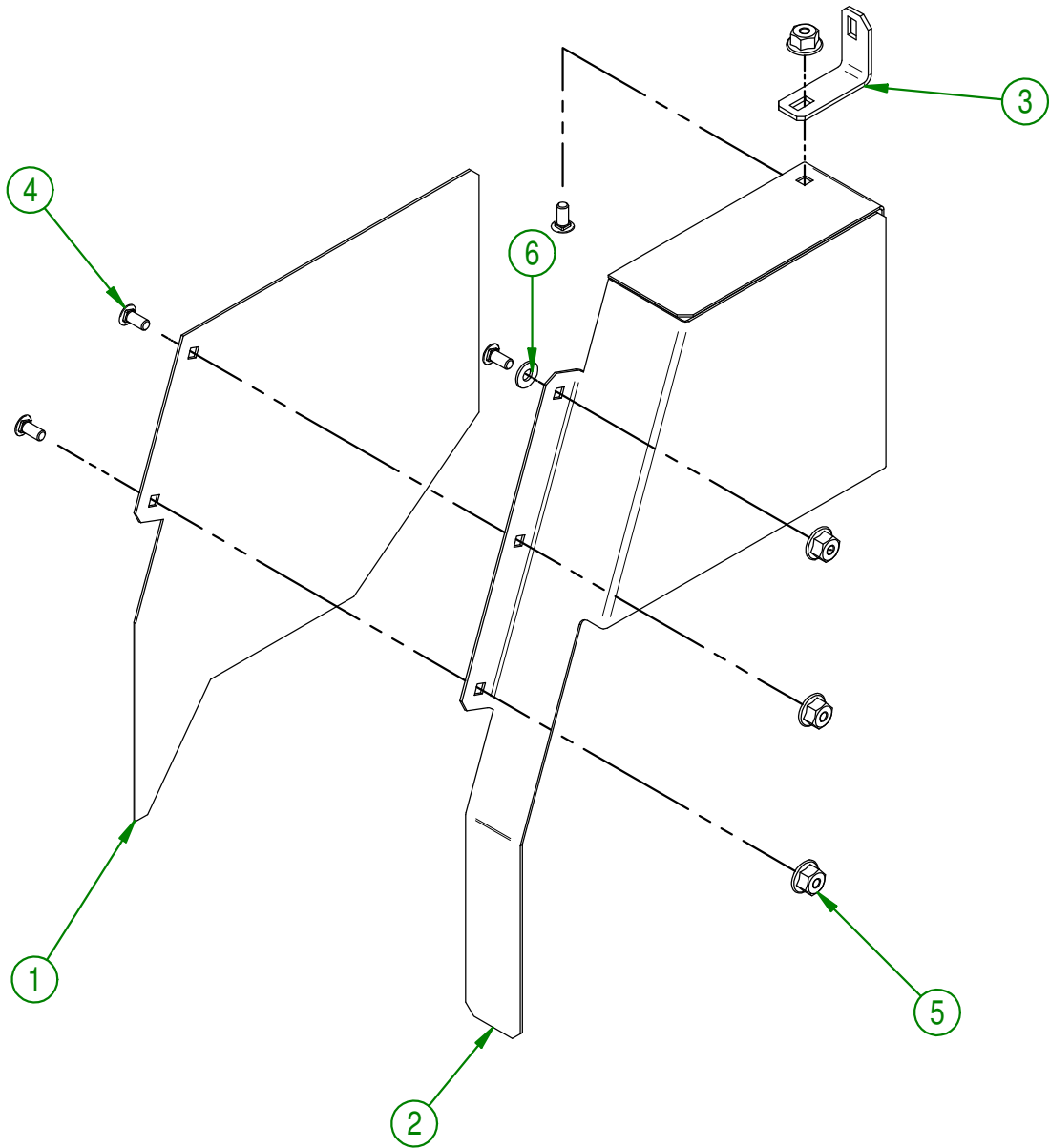

<b>AGRIMETAL</b>	
HONDA MOTOR SHAFT GUARD GROUP.	
CREATION : 06/12/16	ASSEMBLY : <b>23-57-1285</b>
REVISION : 26/10/18	AUTHOR : J.KABWE   Page 29 de 43

23-55-0050

#	PART #	Qty	TITLE
1	23-50-0070	1	CRANK HANDLE
2	23-42-0000	1	CONVEYOR CRANK HANDLE TUBE
3	NC02-22-0008	1	WASHER ZINC 5/16"
4	NC02-32-0011	1	LOCK WASHER ZINC 5/16"
5	NC01-17-0058	1	HEX. BOLT GR2 ZINC 5/16-18 X 3/4"

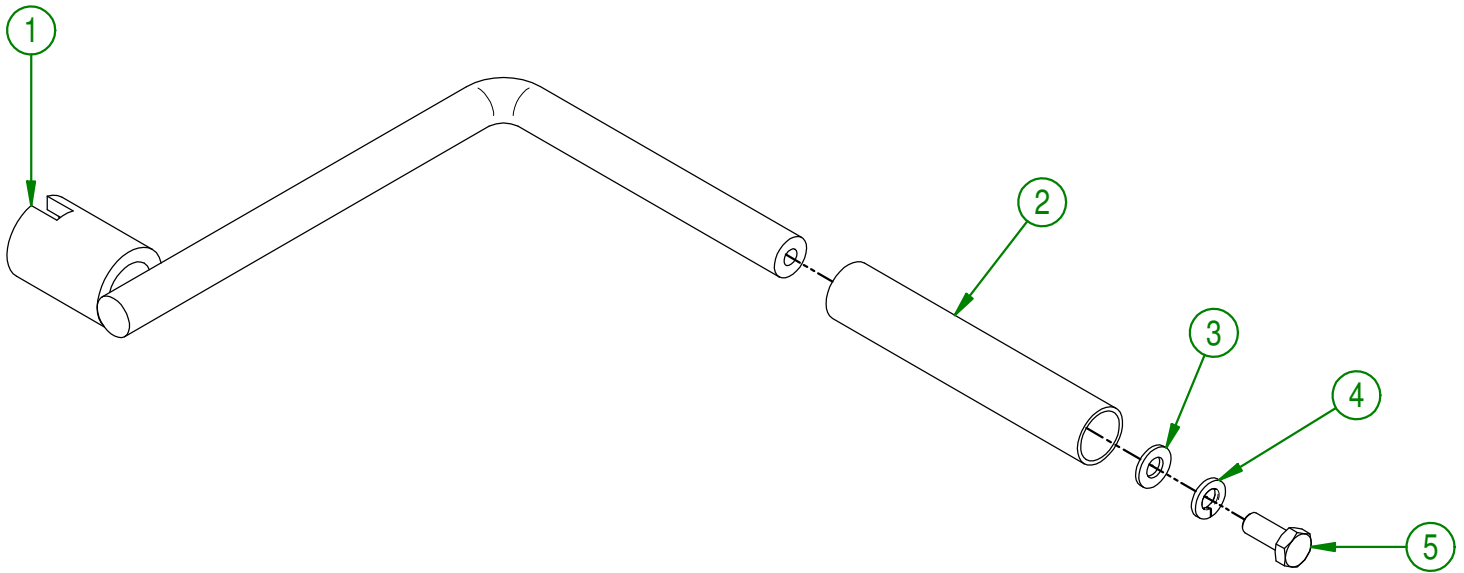

**AGRIMETAL**  
**CRANK HANDLE ASSY.**

CREATION : 06/12/16  
REVISION : 10/01/18

ASSEMBLY : **23-55-0050**

AUTHOR : J.KABWE Page 30 de 43

#	PART #	Qty	TITLE
1	23-50-0040	1	TELESCOPING HITCH
2	23-55-0110	1	HITCH (11/16")
3	NC01-25-0126	2	HEX. BOLT GR5 ZINC 3/8-16 X 4"
4	01-01-2485	4	FLAT WASHER
5	NC02-32-0012	2	LOCK WASHER ZINC 3/8"
6	NC02-07-0018	2	HEX. NUT ZINC 3/8-16
7	38-55-0050	1	JACK
8	NC01-69-1306	1	LOCKING PIN 3/8" X 2 1/2" LG

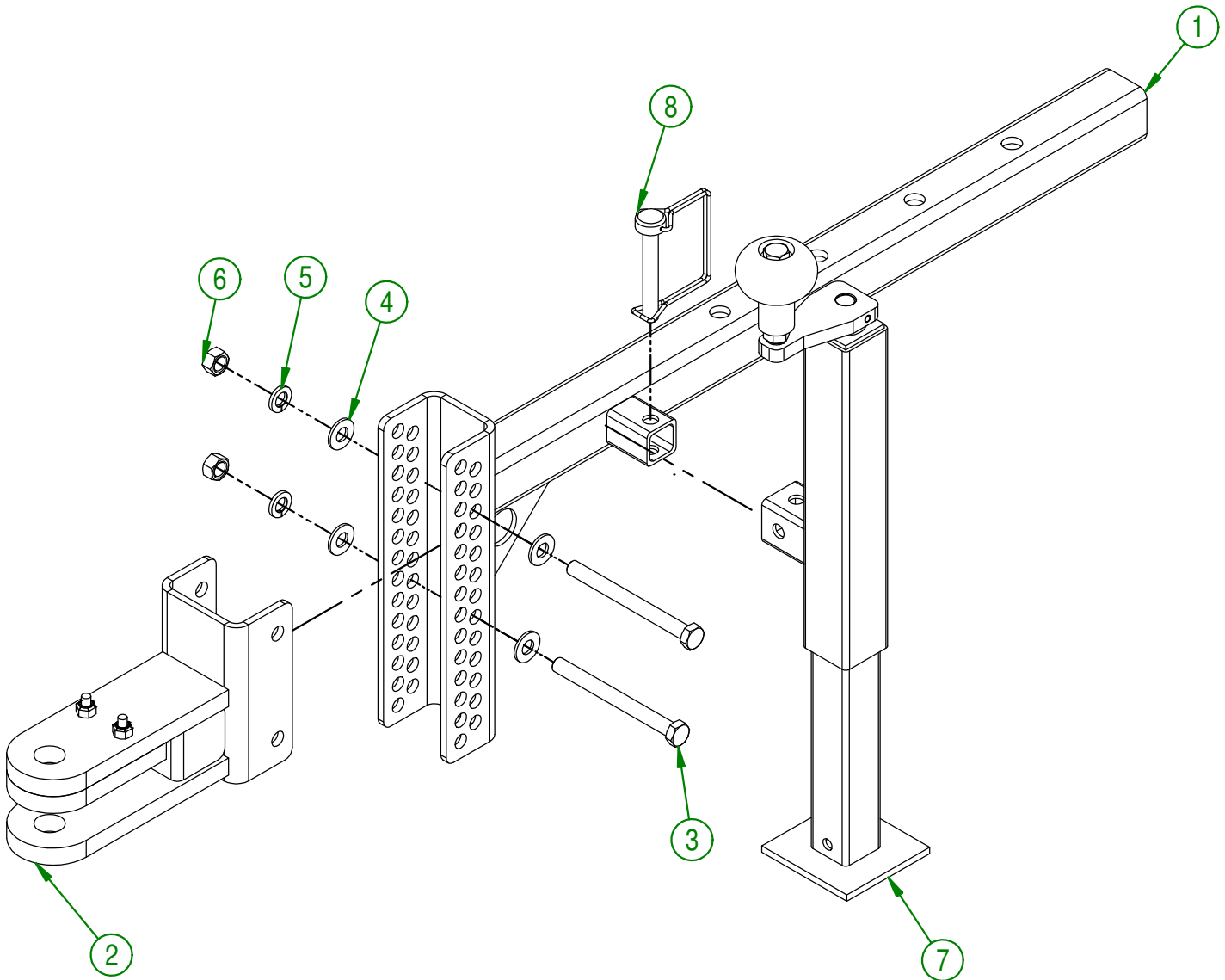

<b>AGRIMETAL</b>	
<b>REMOVIBLE HITCH, HAND CLIP &amp; JACK ASSY</b>	
CREATION : 06/12/16	ASSEMBLY : <b>23-55-0035</b>
REVISION : 01/02/18	AUTHOR : J.KABWE   Page 31 de 43

#	PART #	Qty	TITLE
1	NCI3-30-0237	1	PLASTIC TUBE FOR OPERATOR'S MANUAL
2	NC01-04-0003	3	CARR. BOLT GR2 ZINC 1/4-20 X 3/4"
3	NC02-25-0007	3	WASHER ZINC 0.281 = 9/32
4	NC01-96-0009	3	NYLON-INSERT LOCKNUT ZINC 1/4-20
5	23-98-0507	1	MANUAL OPER. LEAF AND DEBRIS COLLECTOR

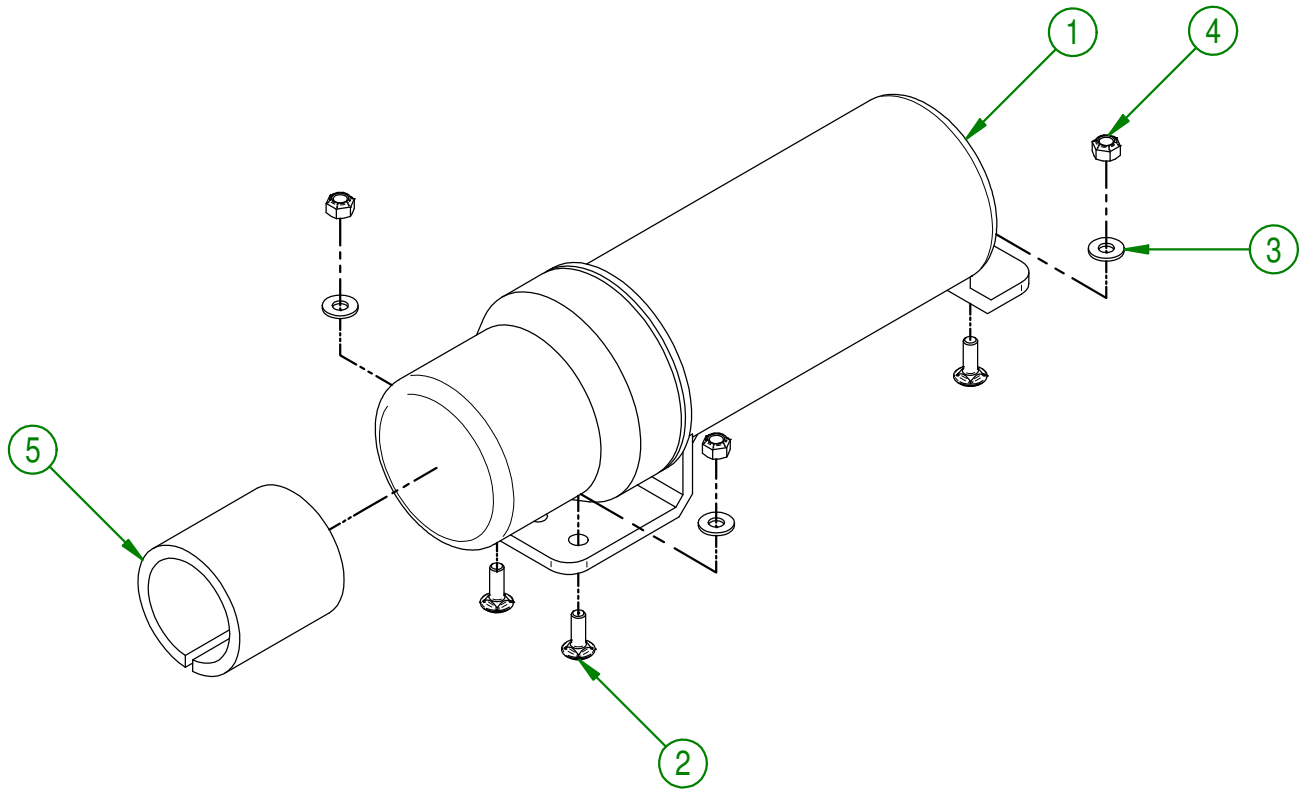

<b>AGRIMETAL</b>	
<b>MANUAL OPER. LEAF AND DEBRIS COLLECTOR ASSY</b>	
CREATION : 06/12/16	ASSEMBLY : <b>23-57-1200</b>
REVISION : 10/01/18	AUTHOR : J.KABWE   Page 32 de 43

#	PART #	Qty	TITLE
1	23-55-0081	1	ROTOR SHAFT HAMMER ASSY.
2	23-50-1070	1	ACCESS DOOR (COUNTER-KNIFES)
3	NC14-75-0008	2	STEEL BEARING ONLY 3 HOLES F4 3 9/16" OD
4	NC14-75-0014	1	STEEL BEARING SB 204-12 X 3/4" ID
5	23-50-1010	1	ACCESS DOOR (ELBOW SIDE)
6	NC14-75-0110	2	BALL BEARING RI2 2RS
7	NC02-14-0017	8	FLANGED NUT GR. B 1/4-20
8	NC14-62-0168	1	IRON PULLEY MA30 X 3/4" DIA. KW 3/16 2 SS
9	01-41-0905	1	SQUARE KEY 3/16" X 1 1/4"TL
10	NC14-25-0265	1	1/2 A-38 V BELT
11	NC01-04-0055	3	CARR. BOLT GR2 ZINC 5/16-18 X 5/8"
12	NC02-14-0006	3	HEX. NUT SPECIAL FLANGET NC 5/16-18 B GRADE

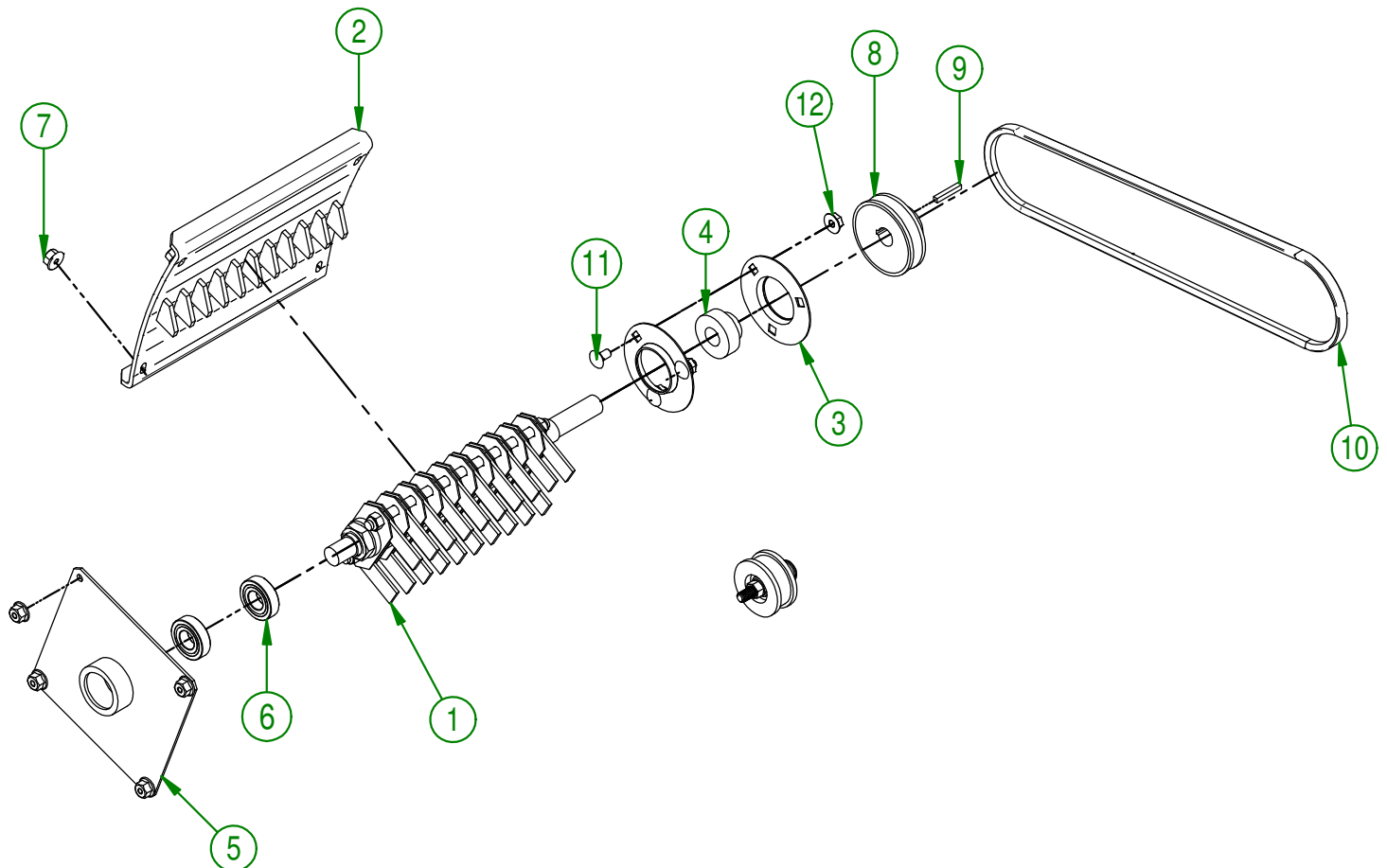

**AGRIMETAL**  
**MULCHING KIT ASSY**

CREATION : 20/02/17  
 REVISION : 01/02/18

ASSEMBLY : **23-57-1266**  
 AUTHOR : J.KABWE | Page 33 de 43

#	PART #	Qty	TITLE
1	23-25-2410	1	HAMMER SHAFT
2	23-01-3045	20	HAMMER SUPPORT
3	NC17-46-0016	9	ROTOR RING
4	NC02-18-8143	10	BLACK SHIM RINGS .134" X 1" X 1/2"
5	23-01-1050	20	HAMMER
6	23-13-0400	2	HAMMER PIVOT SHAFT
7	NC01-96-0011	4	NYLON NUT 3/8-16
8	23-21-0025	2	BOTH EXTREMITY ROTOR SPACER
9	NC01-98-0018	2	HEX. LOCK NUT 7/8-14

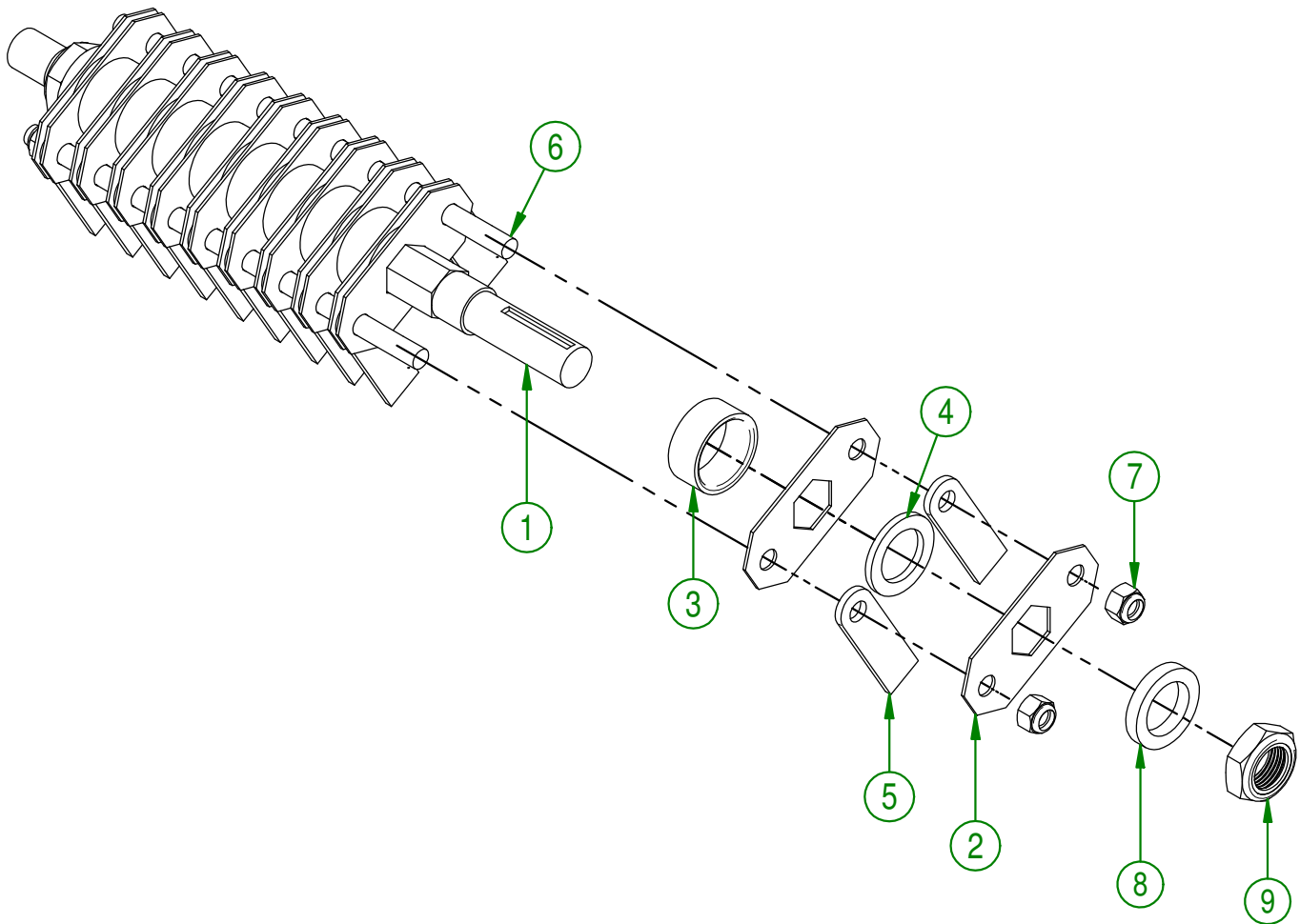

<b>AGRIMETAL</b>	
<b>ROTOR SHAFT HAMMER ASSY.</b>	
CREATION : 07/08/17	ASSEMBLY : <b>23-55-0081</b>
REVISION : 26/10/18	AUTHOR : J.KABWE   Page 34 de 43

23-57-0285

#	PART #	Qty	TITLE
1	23-55-0085	1	IDLER PULLEY ASSY.
2	01-01-2485	1	FLAT WASHER 14 GA X 13/16"OD X 25/64" ID
3	NC02-32-0012	1	LOCK WASHER ZINC 3/8"
4	NC02-07-0018	1	HEX. NUT ZINC 3/8-16
5	NC01-04-0115	1	CARR. BOLT GR2 ZINC 3/8-16 X 2 1/2"
6	21-01-0950	7	FLAT WASHER 10GA 1.005" DIA X 25/64"

23-55-0085

#	PART #	Qty	TITLE
7	36-21-0005	1	IDLER PULLEY ONLY
8	NC14-75-0068	1	BALL BEARING 99502H
9	23-09-0000	1	BALL BEARING PAD
10	NC01-64-0142	1	SNAP RING HOLE 1 3/8"

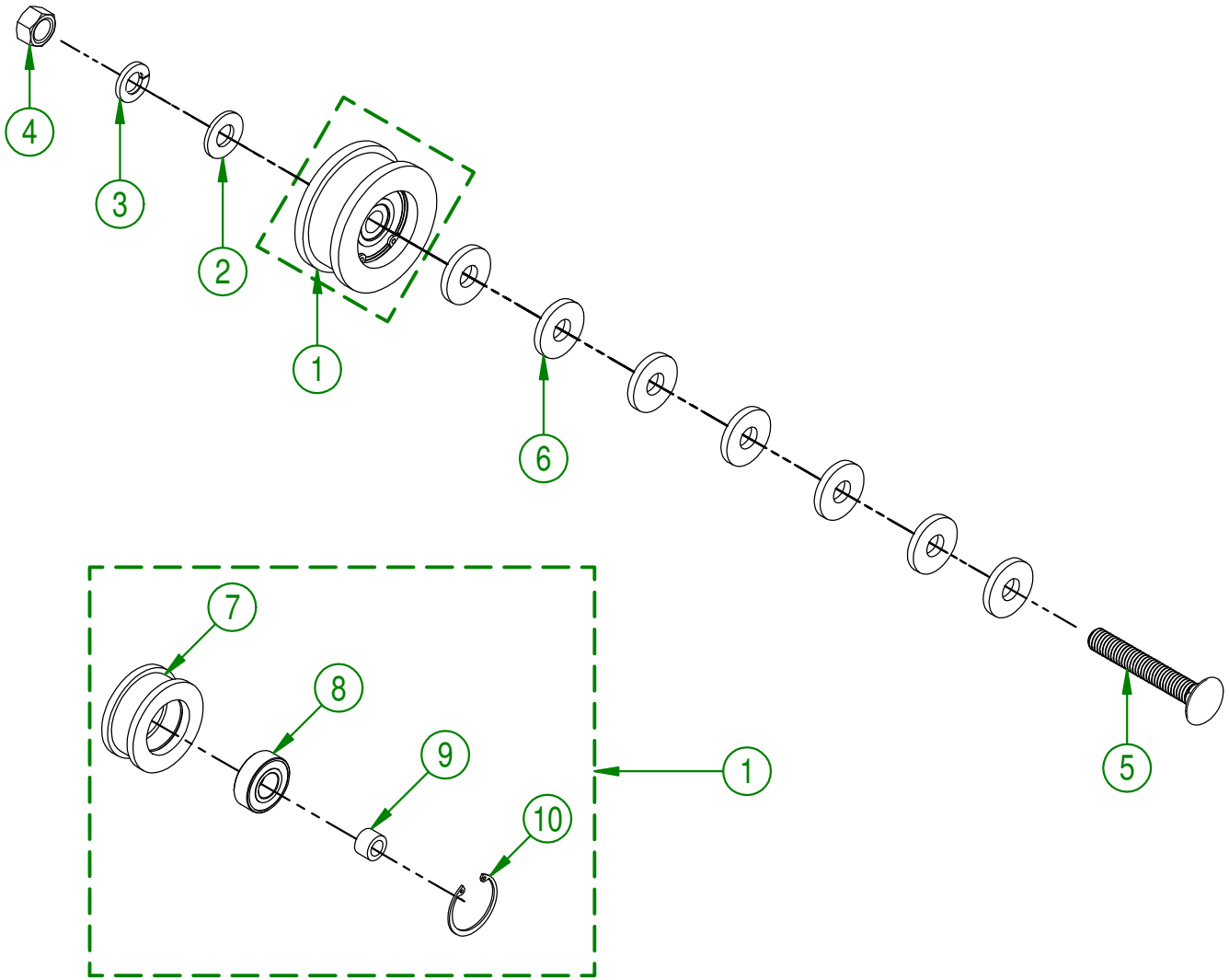

<b>AGRIMETAL</b>	
<b>IDLER PULLEY ASSY. " BOLTS INCLUDED"</b>	
CREATION : 19/09/17	ASSEMBLY : <b>23-57-0285</b>
REVISION : 26/10/18	AUTHOR : J.KABWE   Page 35 de 43



#	PART #	Qty	TITLE
1	23-55-1037	2	3/8" H HYDRAULIC HOSE ASSY. MALE FITTING
2	23-04-0080	1	HYDRAULIC MOTOR GUARD
3	NC01-04-0056	2	CARR. BOLT 5/16-18 X3/4"
4	NC02-32-0011	2	LOCK WASHER ZINC 5/16"
5	NC02-07-0017	2	HEX. NUT 5/16-18
6	23-50-1050	1	DOOR LATCH PIVOT
7	NC02-14-0017	1	FLANGED NUT GR. B 1/4-20
8	23-50-1060	1	HYDRAULIC MOTOR SUPPORT (OPTION)
9	NC01-04-0107	2	CARR. BOLT GR2 ZINC 3/8-16 X 3/4"
10	NC02-32-0012	6	LOCK WASHER ZINC 3/8"
11	NC02-07-0018	6	HEX. NUT ZINC 3/8-16
12	NC01-17-0114	4	HEX. BOLT GR2 ZINC 3/8-16 X 1"
13	01-01-2485	4	FLAT WASHER 14 GA X 13/16"OD X 25/64" ID
14	NC14-55-0027	1	SPROCKET 40B15H X 1" DIA. KW 1/4" 2SS 5/16-18
15	NC14-55-0235	1	SPROCKET 40B30H X DIA. 3/4", KW 3/16". 2SS 5/16-18
16	23-37-1010	1	CHAIN # 40 X 39 3/4" TL + MANUAL DECK CONVEYOR

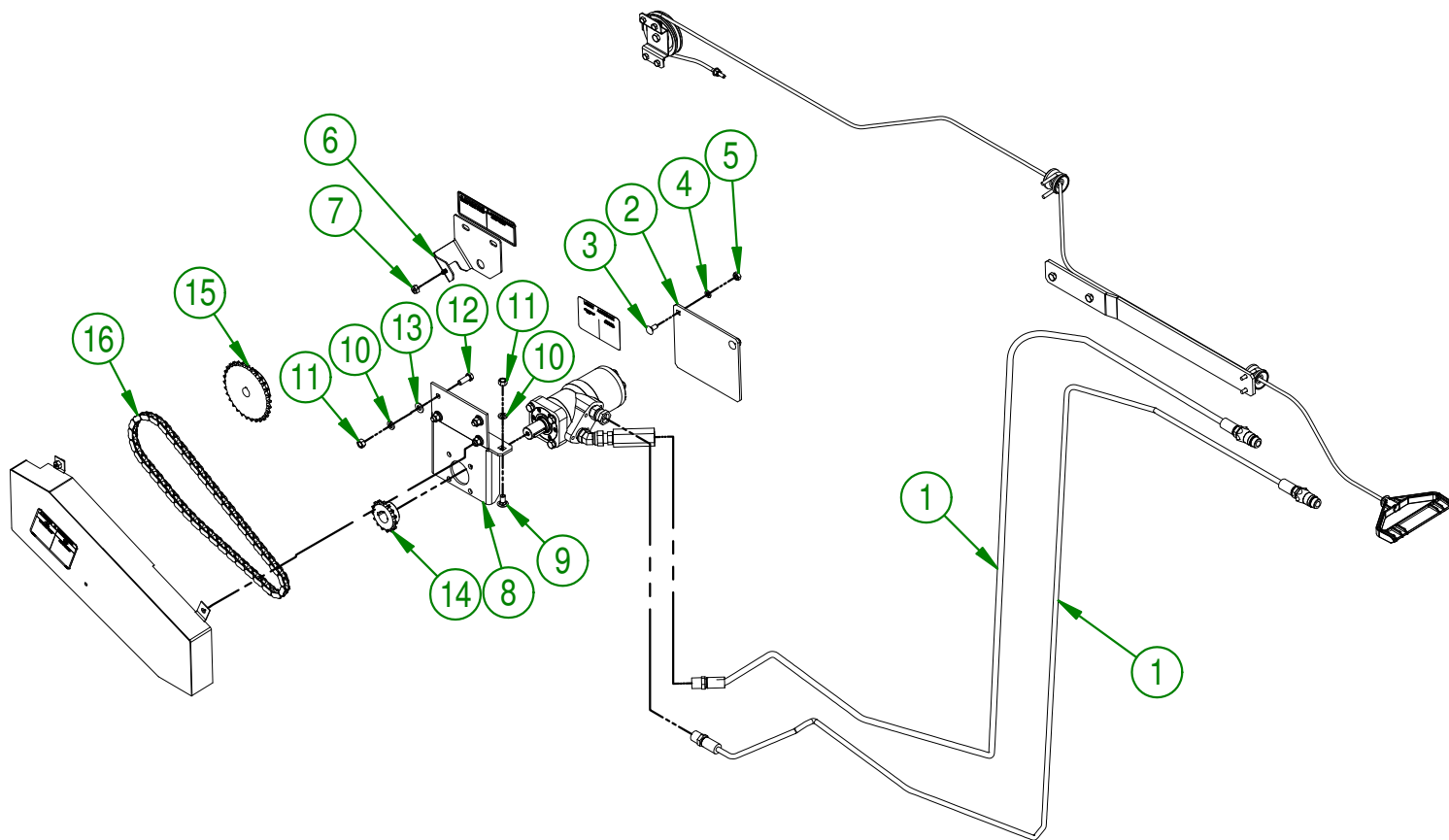

<b>AGRIMETAL</b>	
<b>HYDRAULIC CONVEYOR KIT (OPTION)</b>	
CREATION : 07/09/17	ASSEMBLY : <b>23-55-1025</b>
REVISION : 10/06/19	AUTHOR : J.KABWE Page 36 de 43

#	PART #	Qty	TITLE
1	NCI3-80-0065	1	STARTER HANDLE
2	NCI7-02-0193	1	LEAF COLLECTOR CABLE 91 1/4" ASSY.
3	NC01-64-0239	1	3/32 ALUMINIUM STOP RING
4	NC02-25-0007	1	WASHER ZINC 0.281 = 9/32
5	NC01-96-0009	1	NYLON-INSERT LOCKNUT ZINC 1/4-20

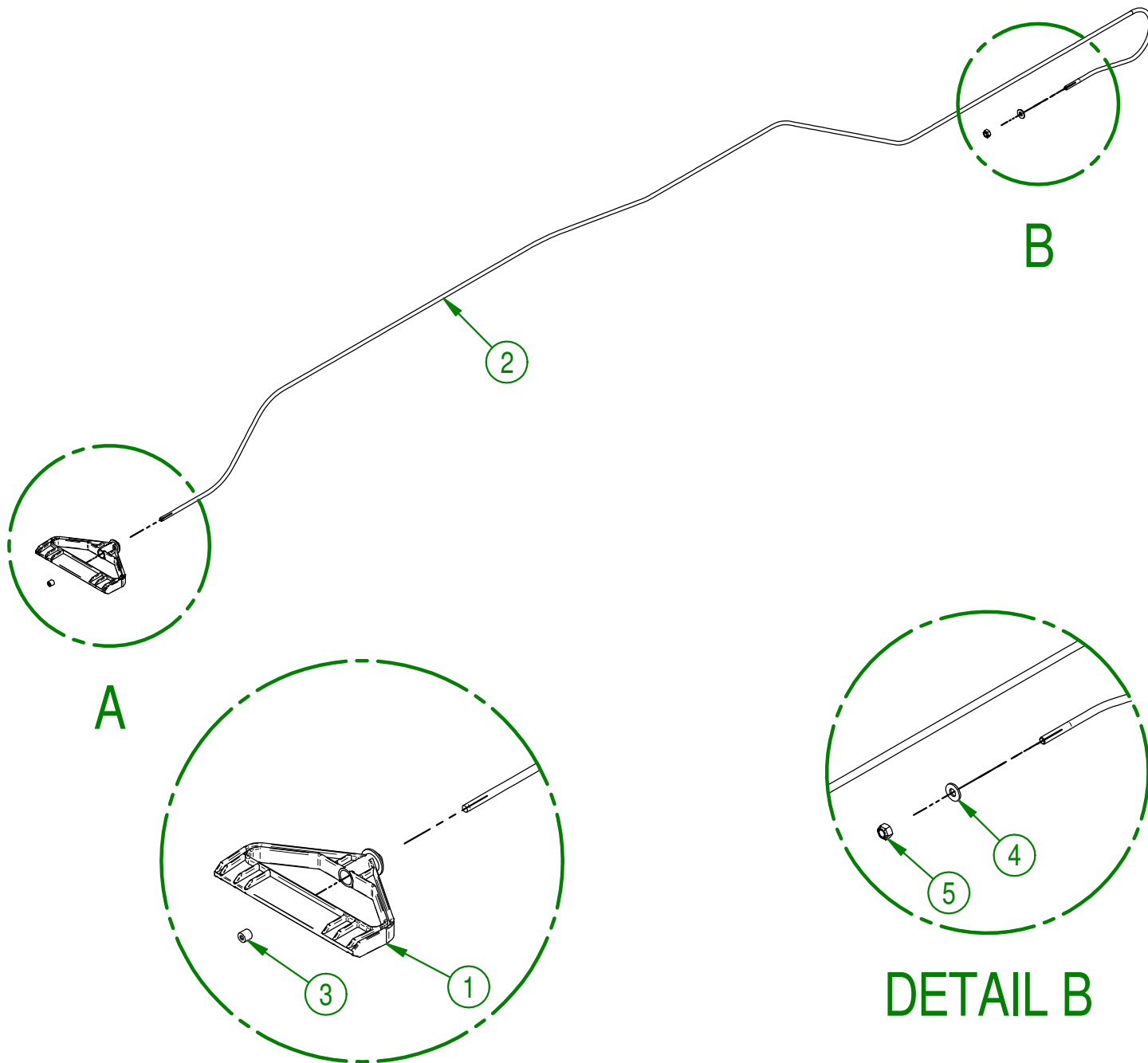

A

B

DETAIL A

DETAIL B

<b>AGRIMETAL</b>	
BACK DOOR HANDLE ASSY.	
CREATION : 21/09/17	ASSEMBLY : <b>23-55-1010</b>
REVISION : 10/01/18	AUTHOR : J.KABWE Page 37 de 43

#	PART #	Qty	TITLE
1	NC14-45-0004	1	HYDRAULIC MOTOR TB MODEL
2	NC13-45-0084	1	UNION 7/8-14 MALE SAE10 ORINGX1/2 FEM.TOUR.N
3	NC13-45-0046	1	45°-7/8-14 MALE O RING X 1/2 FEM.TOUR.NPT PT
4	NC13-45-0029	1	HEX. NIPPLE 1/2 MALE NPT X 1/2 MALE NPT
5	NC13-45-0020	1	CHECK VALVE 1/2 NPT
6	NC02-32-0012	4	LOCK WASHER ZINC 3/8"
7	NC01-17-0114	4	HEX. BOLT GR2 ZINC 3/8-16 X 1"

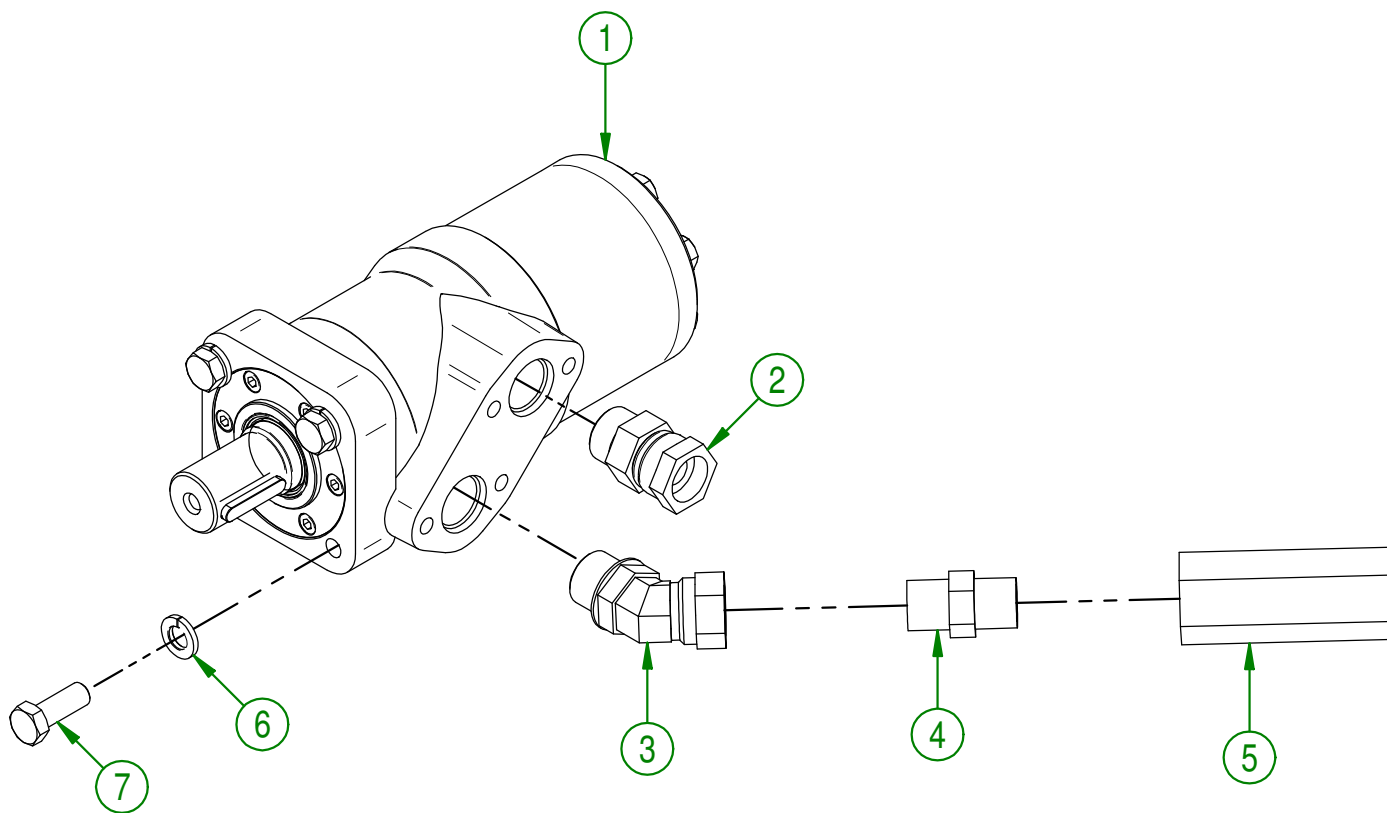

<b>AGRIMETAL</b>	
HYDRAULIC MOTOR ASSY. (OPTION)	
CREATION : 07/09/17	ASSEMBLY : <b>23-55-1060</b>
REVISION : 10/01/18	AUTHOR : J.KABWE   Page 38 de 43

#	PART #	Qty	TITLE
1	23-01-2470	1	PULLEY SUPPORT
2	23-01-2475	1	CABLE STOPPER
3	NC14-63-0001	1	PULLEY PLASTIC 3 1/2" OD X BEARING 3/8"
4	NC01-17-0117	1	HEX. BOLT GR2 ZINC 3/8-16 X 1 3/4"
5	NC02-32-0012	1	LOCK WASHER ZINC 3/8"
6	NC02-07-0018	1	HEX. NUT ZINC 3/8-16
7	NC01-17-0003	4	HEX. BOLT GR2 ZINC 1/4-20 X 5/8"
8	NC01-96-0009	4	NYLON-INSERT LOCKNUT ZINC 1/4-20

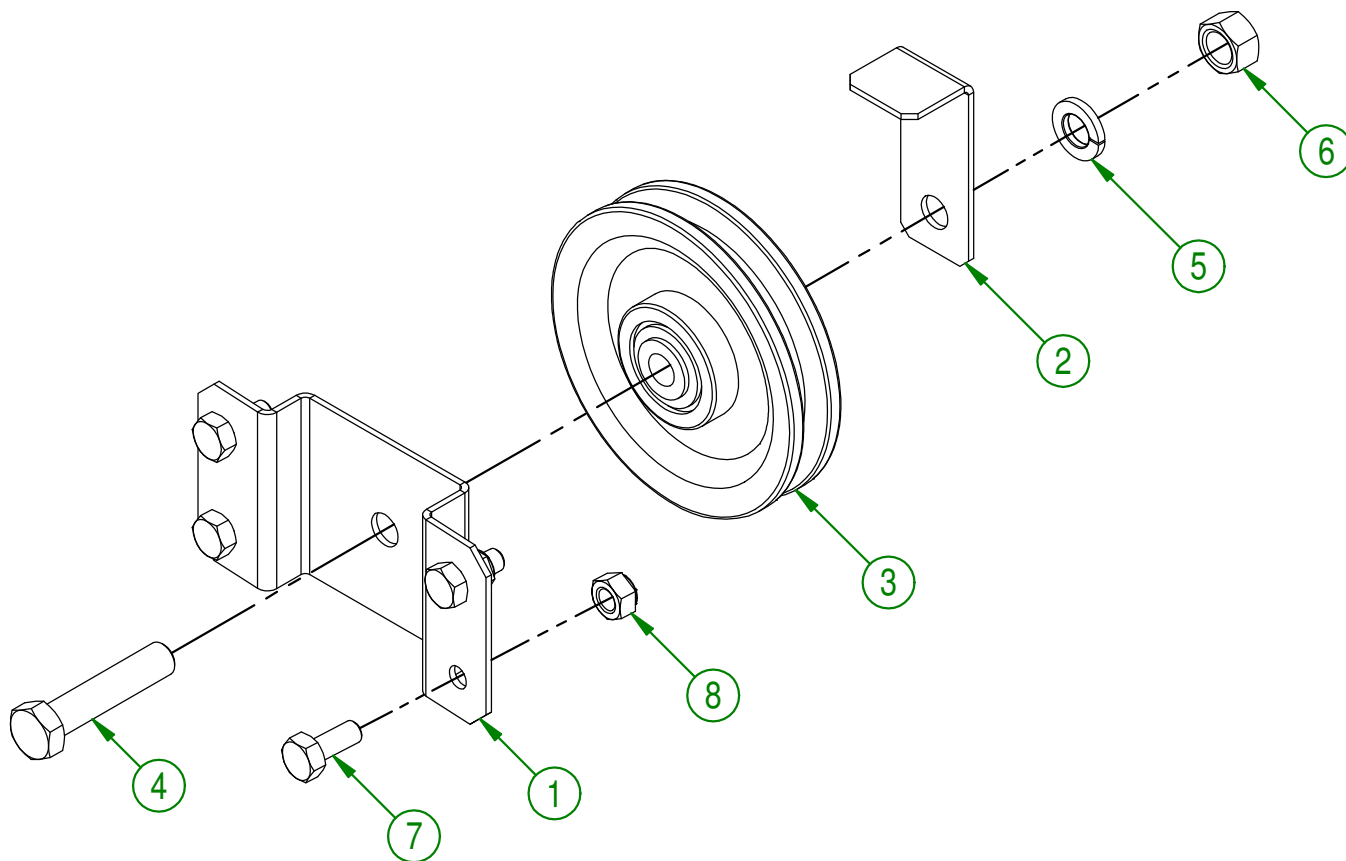

<b>AGRIMETAL</b>	
<b>PULLEY SUPPORT ASSY</b>	
CREATION : 07/09/17	ASSEMBLY : <b>23-55-1065</b>
REVISION : 10/01/18	AUTHOR : J.KABWE   Page 39 de 43

#	PART #	Qty	TITLE
1	23-04-0215	1	DOOR CABLE SUPPORT
2	NC01-17-0114	2	HEX. BOLT GR2 ZINC 3/8-16 X 1"
3	01-01-2485	2	FLAT WASHER
4	NC02-32-0012	2	LOCK WASHER ZINC 3/8"
5	NC02-07-0018	2	HEX. NUT ZINC 3/8-16
6	NC13-80-0203	2	REAR DOOR CABLE SLEEVE
7	NC01-61-0001	2	U BOLT ZINC 1/4-20 X 2 INSIDE
8	NC02-22-0007	4	WASHER 1/4" DIA. X 6/16" OD

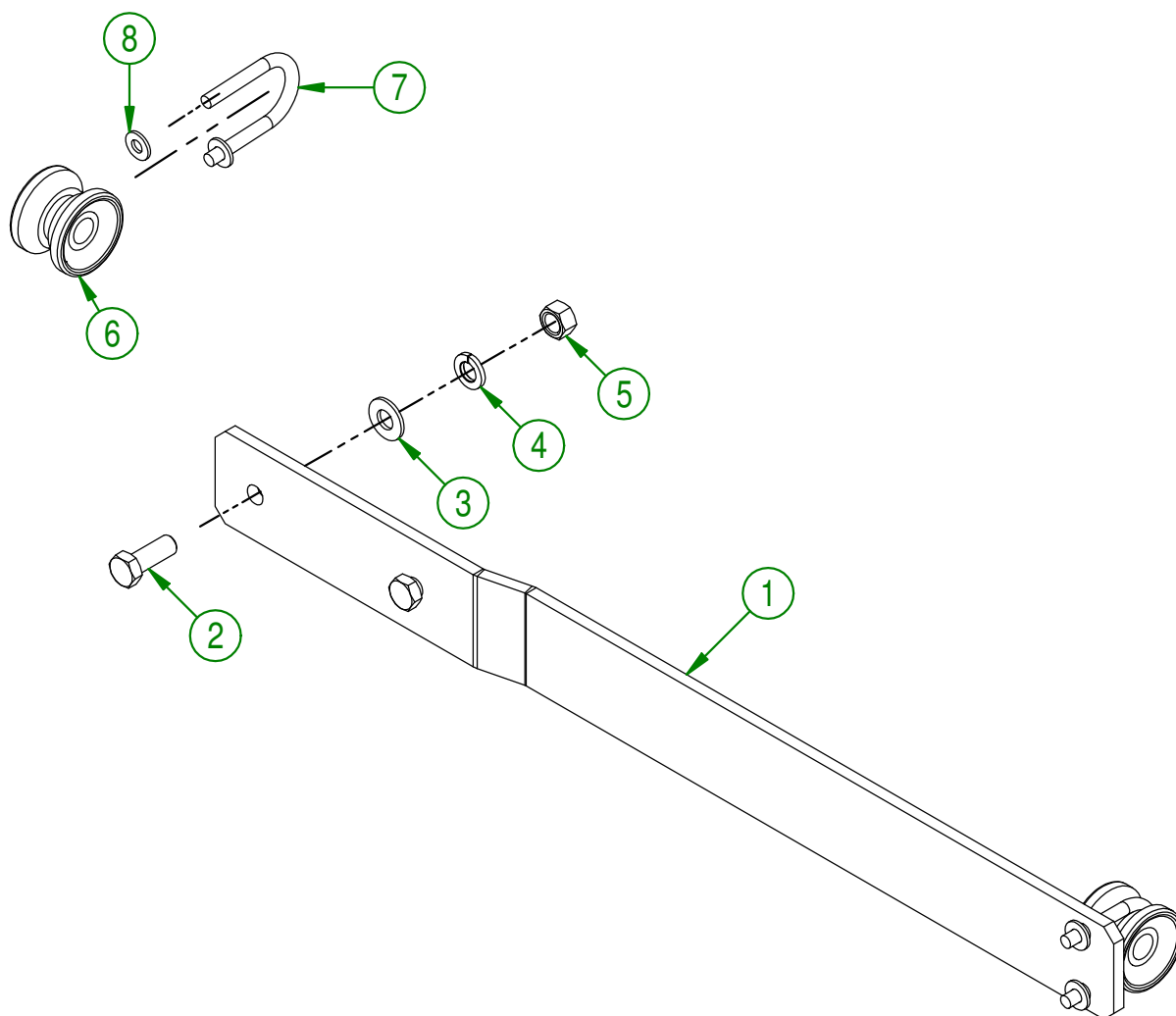

<b>AGRIMETAL</b>	
<b>DOOR CABLE SUPPORT GROUP.</b>	
CREATION : 07/09/17	ASSEMBLY : <b>23-57-1245</b>
REVISION : 01/02/18	AUTHOR : J.KABWE   Page 40 de 43

#	PART #	Qty	TITLE
1	23-50-1075	1	CHAIN GUARD
2	23-41-0137	1	STEEL WIRE CONVEYOR PROTECTION DIA. 1/16" X 15" TL
3	NC01-64-0005	2	OVAL SLEEVE (ALUMINUM)
4	NC01-17-0002	1	HEX. BOLT GR2 ZINC 1/4-20 X 1/2"
5	NC02-14-0017	1	FLANGED NUT GR. B 1/4-20

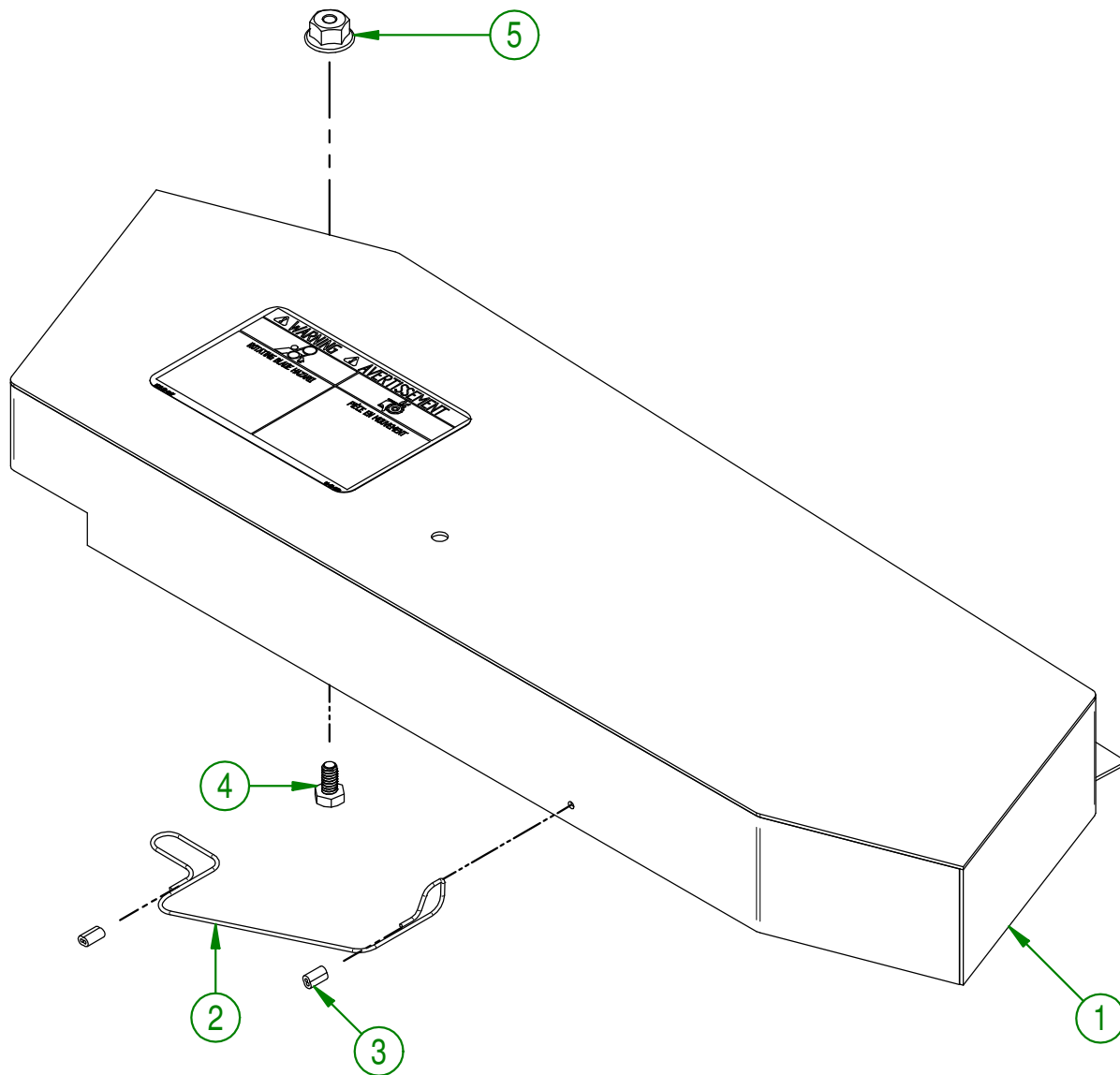

<b>AGRIMETAL</b>	
CHAIN GUARD "STICKER INCLUDED" (HYDRAULIC OPTION)	
CREATION : 08/09/17	ASSEMBLY : <b>23-57-1025</b>
REVISION : 26/10/18	AUTHOR : J.KABWE   Page 41 de 43

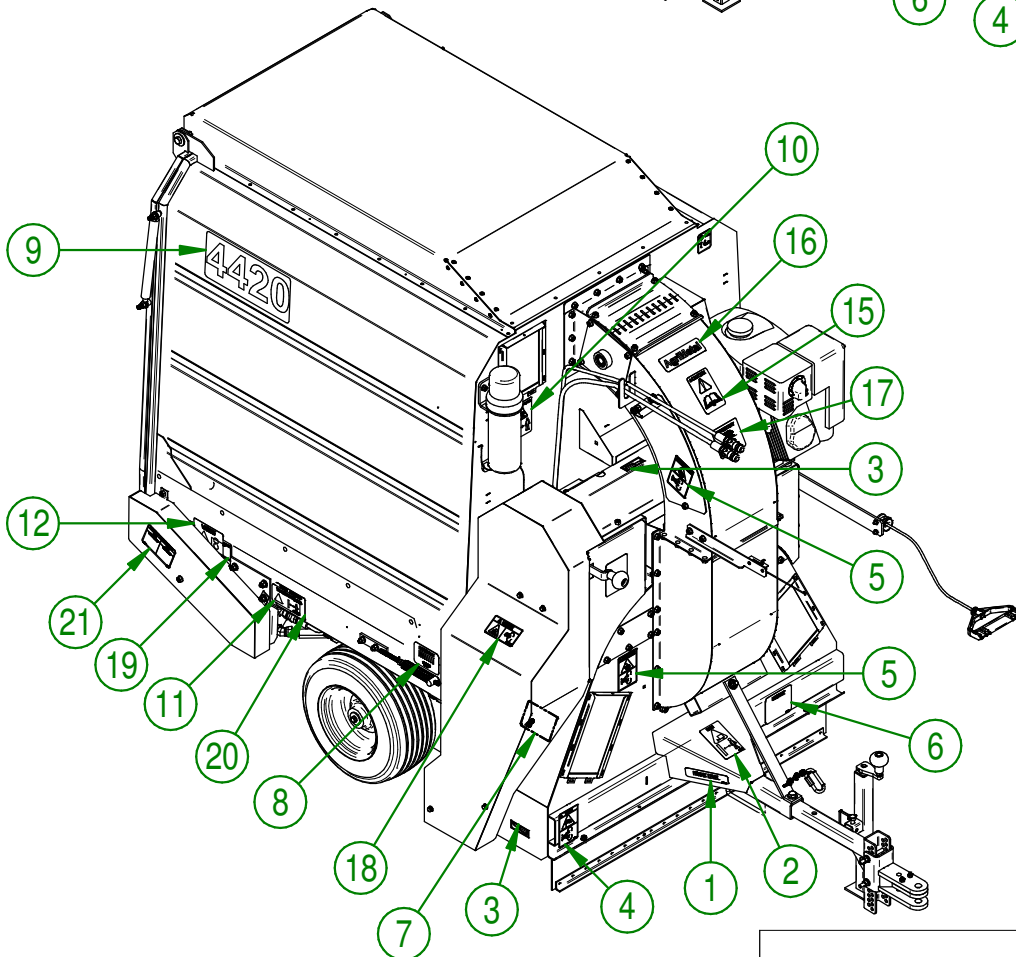
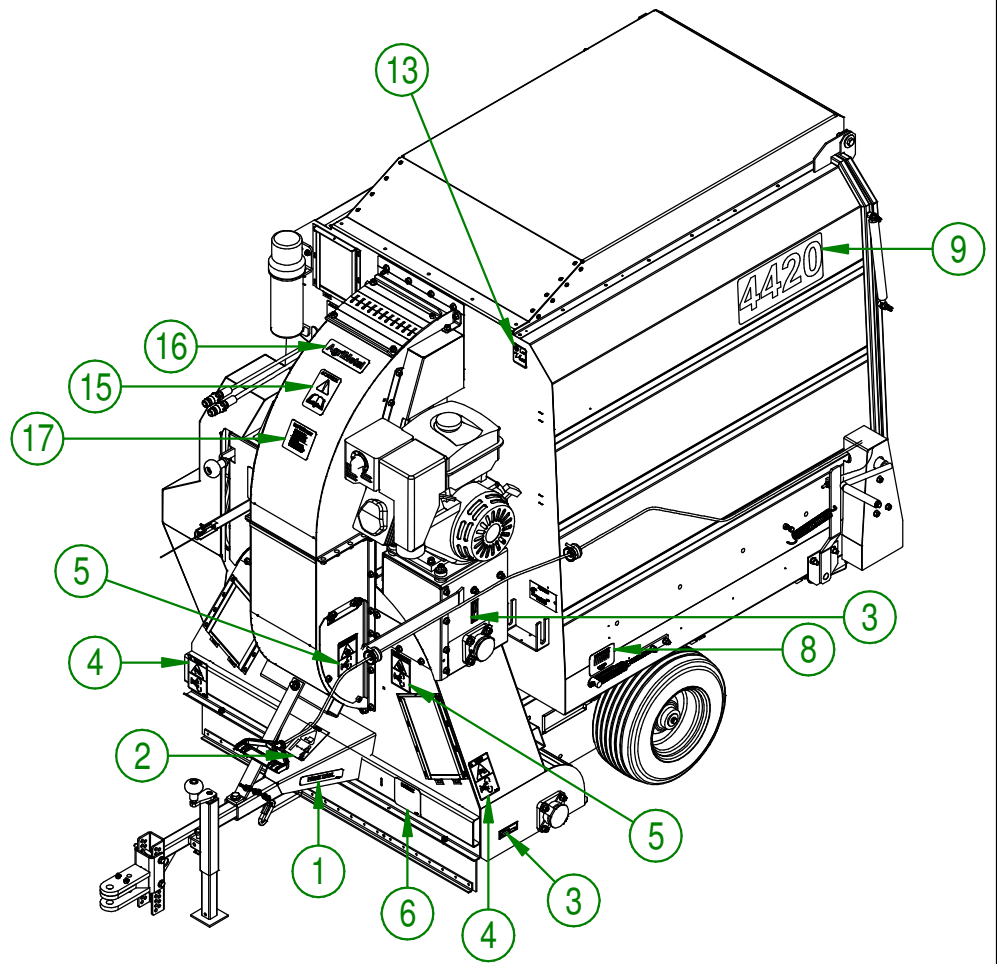

<b>AGRIMETAL</b>	
<b>LEAF COLLECTOR 4420 (HAMMER) 9 HP HONDA</b>	
CREATION : 21/09/17	ASSEMBLY : <b>23-99-0515</b>
REVISION : 08/09/21	AUTHOR : J.KABWE

#	PART #	Qty	TITLE
1	NC13-33-0052	2	STICKER FRAME LEVEL
2	NC13-33-0297	1	STICKER TIMON UP
3	NC13-33-0024	6	STICKER GREASE HERE
4	NC13-33-0190	2	STICKER WARNING ROTATING BLADE HAZARD
5	NC13-33-0186	4	STICKER (DANGER)
6	NC13-33-0152	1	STICKER RUBBER DOWN IMPORTANT
7	NC13-33-0290	1	STICKER DANGER
8	NC13-33-0070	2	STICKER SPRING IMPORTANT STICKER AT 3 1/2 INCHES, 89 MM
9	NC13-33-0140	2	STICKER FOR 4420 LEAF COLLECTOR
10	NC13-33-0192	2	STICKER (PROJECTION RISK)
11	NC13-33-0288	1	STICKER WARNING HIGH-PRESSURE LIQUID
12	NC13-33-0289	1	STICKER WARNING
13	NC13-33-0337	1	STICKER 74 DB
14	NC13-33-0035	1	STICKER AGRIMETAL
15	NC13-33-0183	1	STICKER CAUTION OPERATION MANUAL
16	NC13-33-0002	1	STICKER AGRIMETAL
17	NC13-33-0151	1	STICKER (IMPORTANT TO PREVENT ENGINE FAILURE...)
18	NC13-33-0276	1	STICKER (WARNING)
19	NC13-33-0113	1	STICKER WARNING
20	NC13-33-0046	1	STICKER HIGH-PRESSURE FLUID HAZARD
21	NC13-33-0017	1	STICKER WARNING

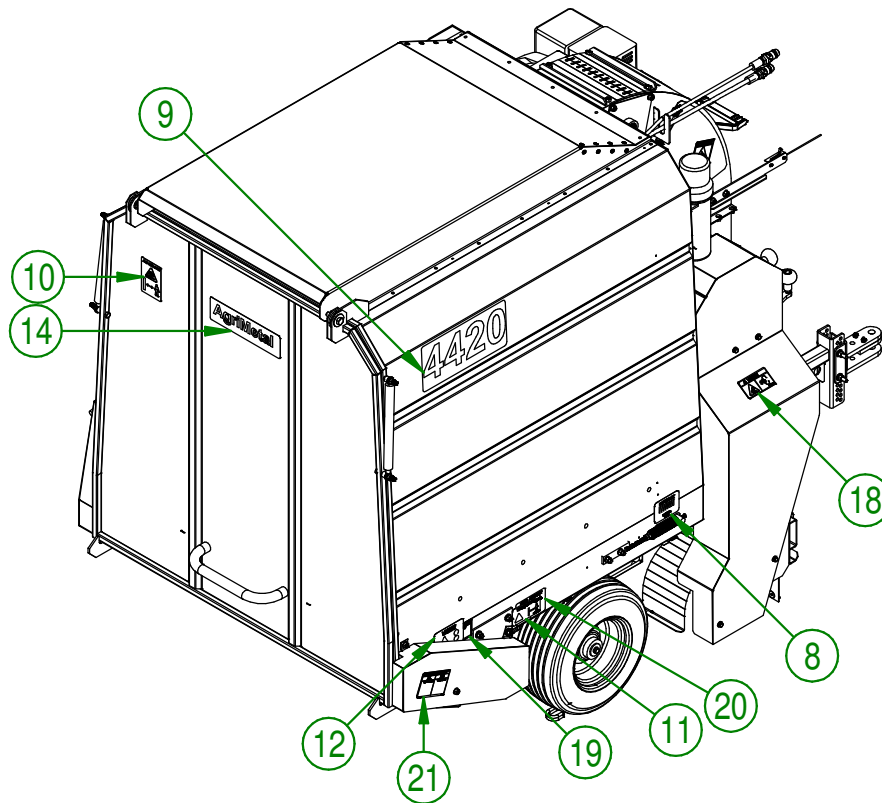

<b>AGRIMETAL</b>	
<b>LEAF COLLECTOR 4420 (HAMMER) 9 HP HONDA</b>	
CREATION : 21/09/17	ASSEMBLY : <b>23-99-0515</b>
REVISION : 08/09/21	AUTHOR : J.KABWE