

# AgriMetal

## PARTS LIST

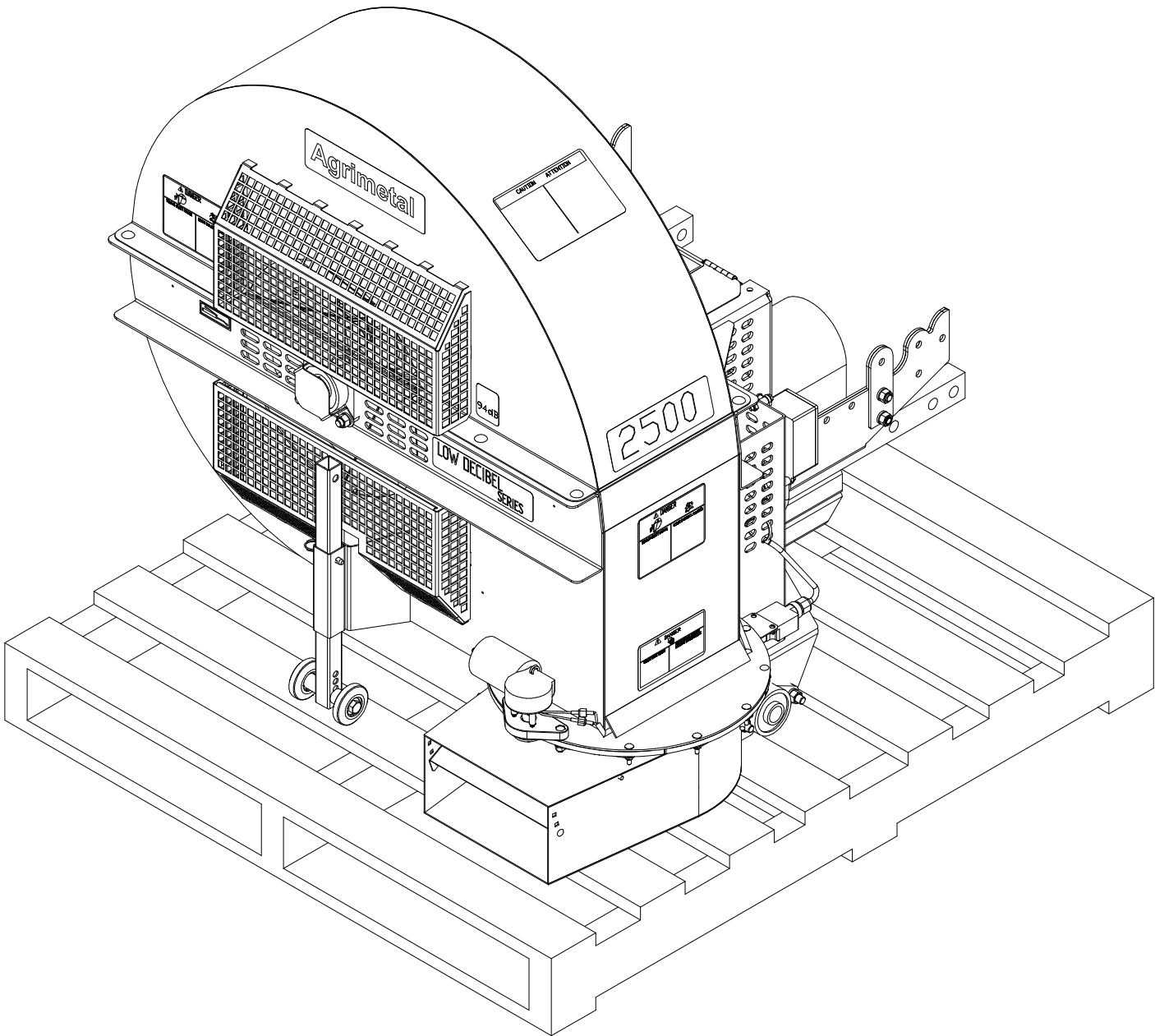

**BW 2500-F180 JD-1500**

#	PART #	Qty	TITLE
1	25-55-0710	1	SERIAL NUMBER PLATE

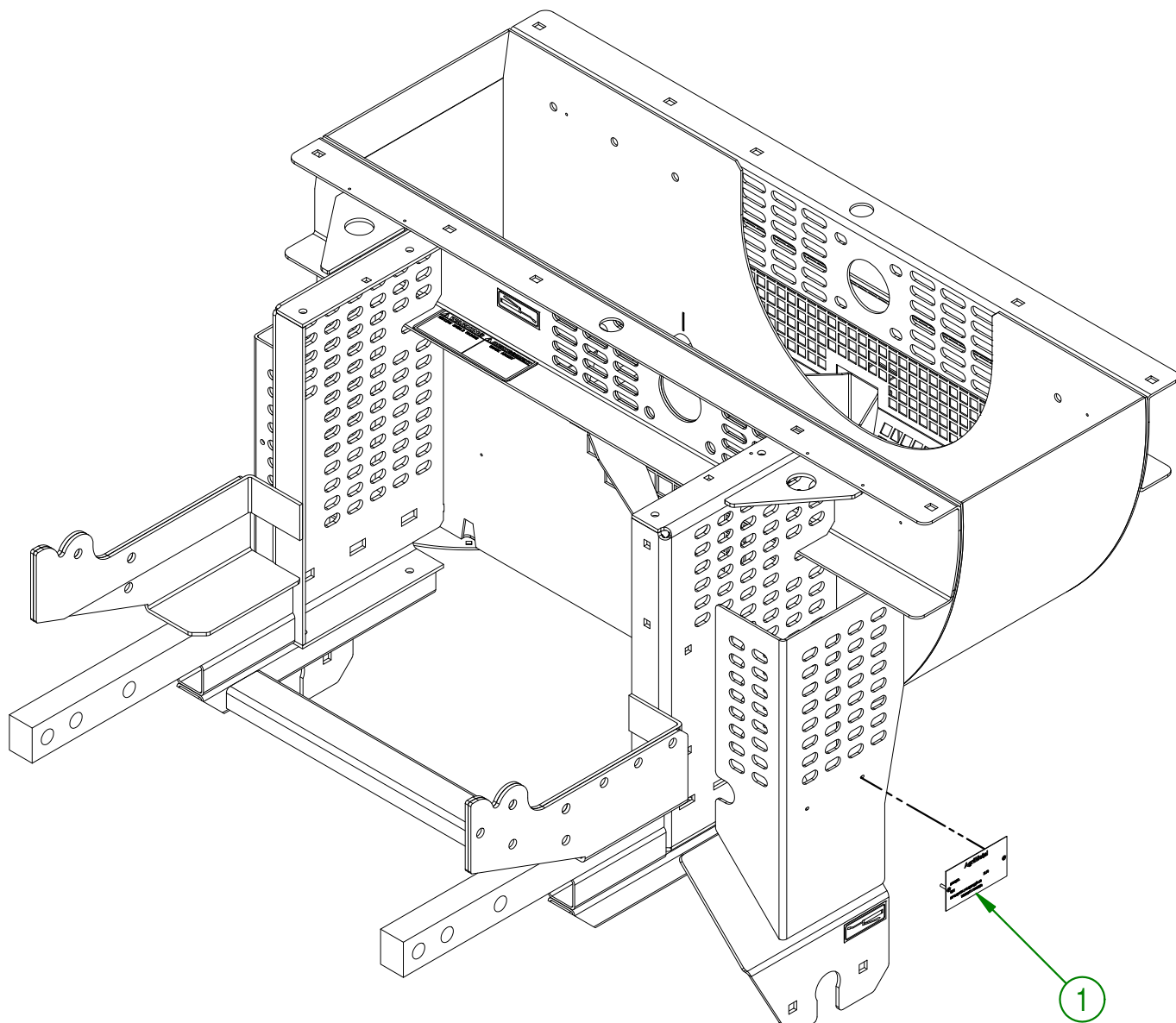

<b>AGRIMETAL</b>		
<b>ASSEMBLY CASING BW 2500-F180</b>		
CREATION : 22-06-2016	ASSEMBLY :	32-57-4000
REVISION : 06-08-2018	AUTHOR : S.B	Page 1 de 19

#	PART #	Qty	TITLE
1	32-50-4565	2	LIFTING STOP EXTENSION
2	NC01-17-0248	2	HEX. BOLT GR2 ZINC 1/2-13 X 1 1/4"
3	NC01-17-0247	2	HEX. BOLT GR2 ZINC 1/2-13 X 1"
4	NC02-07-0020	4	HEX. NUT ZINC 1/2-13
5	NC02-32-0014	4	LOCK WASHER ZINC 1/2"

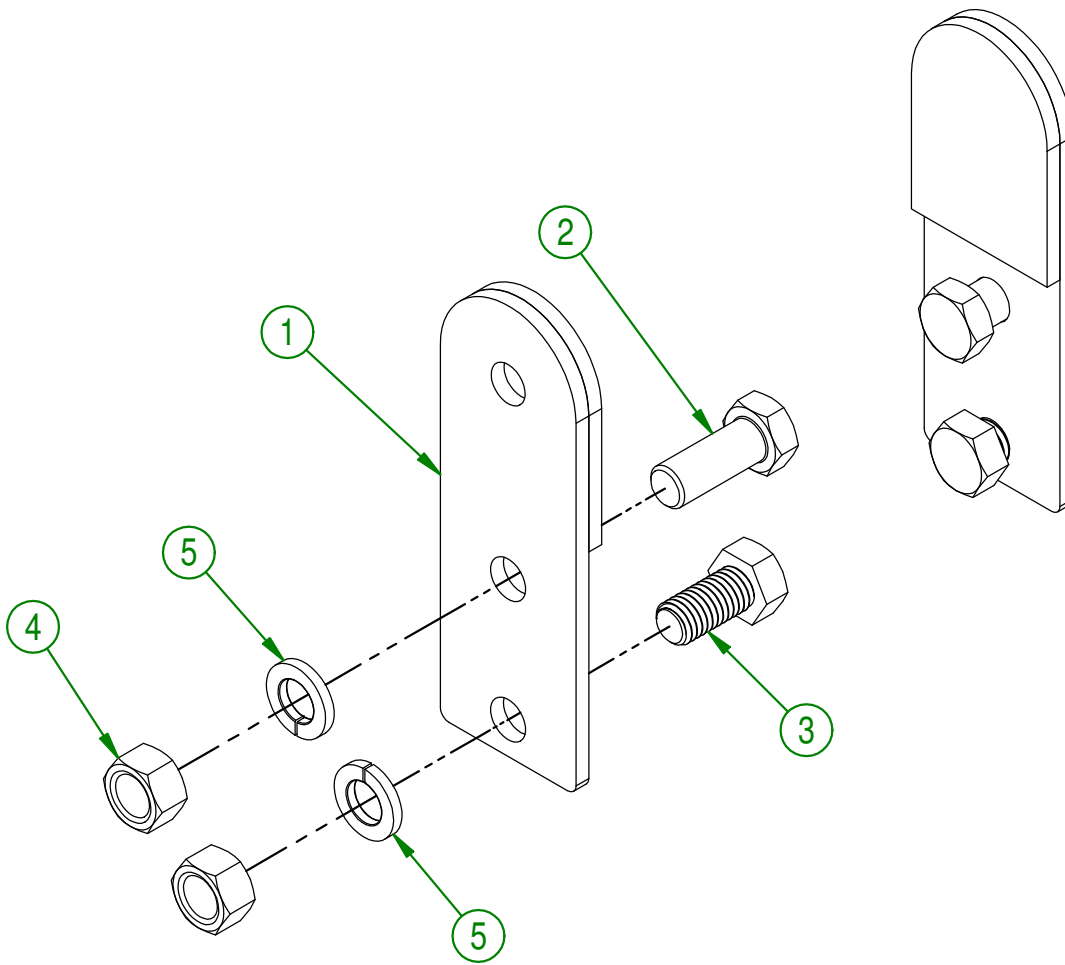

<b>AGRIMETAL</b>	
LIFTING STOP EXTENSION GROUP.	
CREATION : 29/03/18	ASSEMBLY : <b>32-57-4265</b>
REVISION : 12/04/18	AUTHOR : F.HÉLIE
	Page 2 de 19

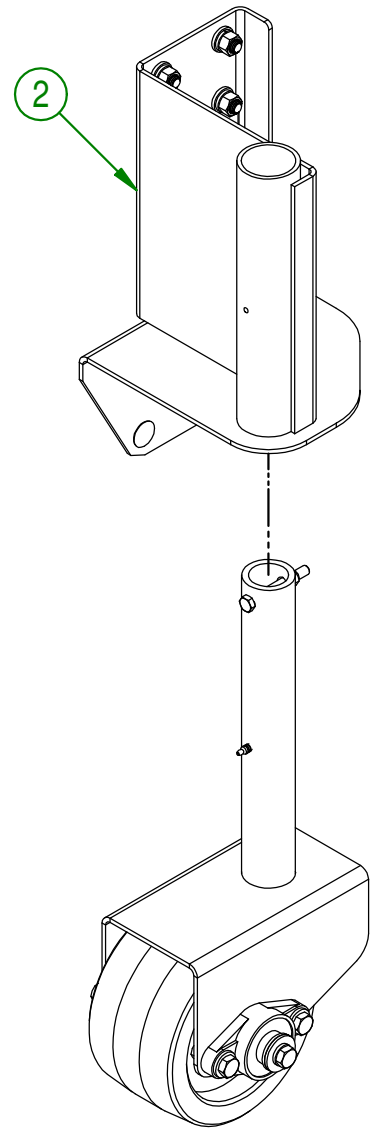
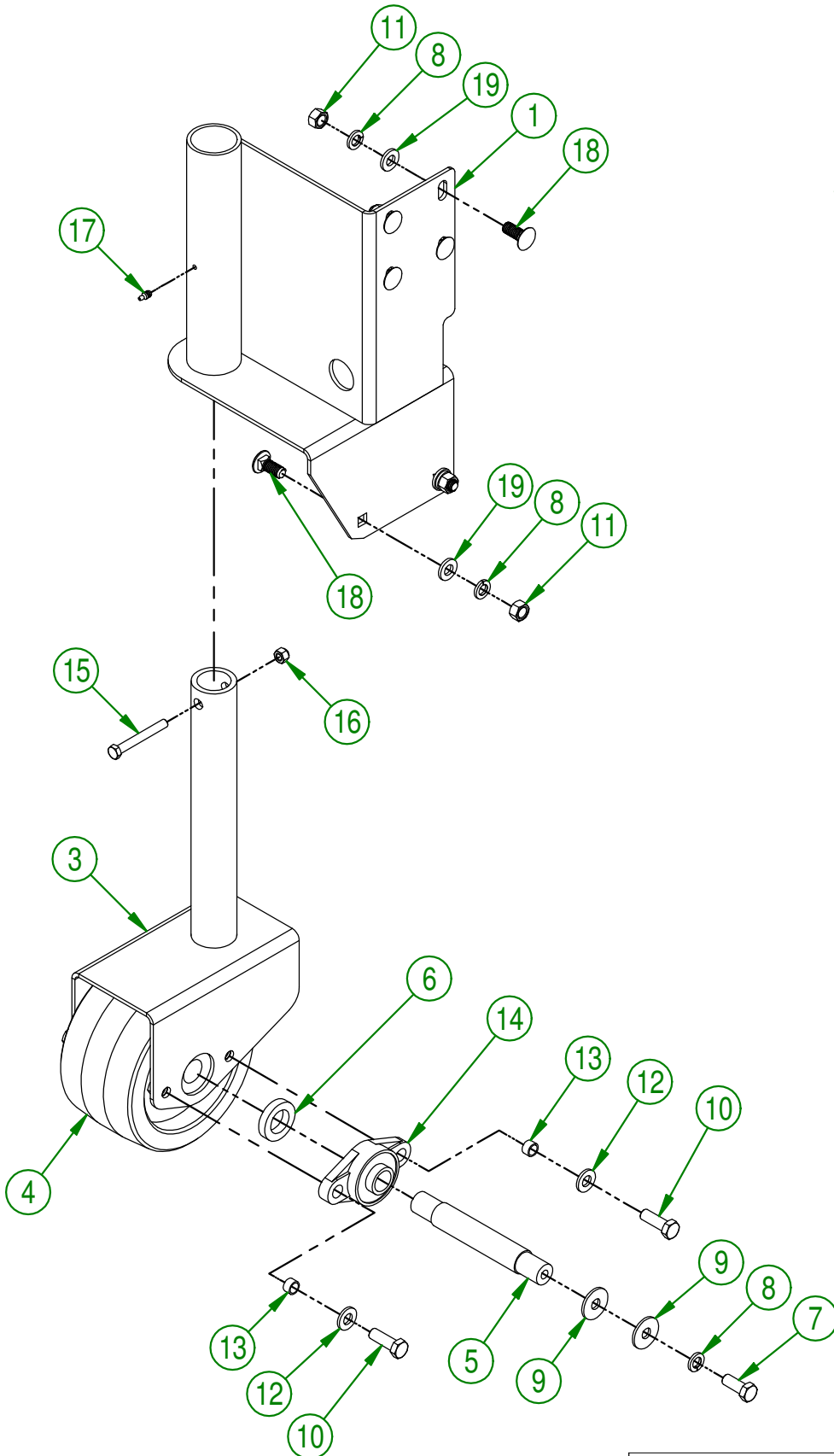

<b>AGRIMETAL</b>	
<b>SWIVEL WHEEL (OPTION)</b>	
CREATION : 12/01/18	ASSEMBLY : <b>32-57-1515</b>
REVISION : 15/01/18	AUTHOR : F.HÉLIE      Page 3 de 19

#	PART #	Qty	TITLE
1	32-50-4540	1	SWIVEL WHEEL SUPPORT (LEFT)
2	32-50-4550	1	SWIVEL WHEEL SUPPORT (RIGHT)
3	32-50-4545	2	SWIVEL WHEEL BRACKET
4	32-42-0000	2	SWIVEL WHEEL
5	32-13-0000	2	SWIVEL WHEEL SHAFT
6	32-04-0330	4	SWIVEL WHEEL AXLE BUSHING
7	NC01-17-0248	4	HEX. BOLT GR2 ZINC 1/2-13 X 1 1/4"
8	NC02-32-0014	24	LOCK WASHER ZINC 1/2"
9	01-01-1660	8	WASHER SPACER
10	NC01-17-0249	8	HEX. BOLT GR2 ZINC 1/2-13 X 1 1/2"
11	NC02-07-0020	20	HEX. NUT ZINC 1/2-13
12	NC02-25-0011	8	WASHER SAE ZINC 17/32 ID
13	NC13-80-0061	8	PAD STEEL POWDER 1/2" X 5/8" X 3/8"
14	01-38-0000	4	FLANGE BEARING UCFL 205-16 X 1" DIA.
15	NC01-17-0122	2	HEX. BOLT GR2 ZINC 3/8-16 X 3"
16	NC01-96-0011	2	NYLON NUT 3/8-16
17	NC01-69-0785	2	STRAIGHT GREASE FITTING 1/4-28
18	NC01-04-0234	12	CARR.BOLT GR2 ZINC 1/2-13 X 1 1/4"
19	01-01-0925	12	WASHER

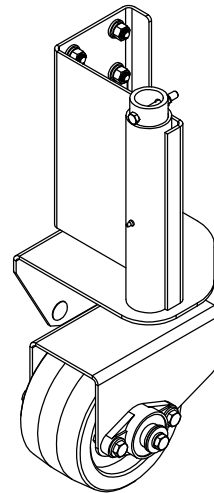
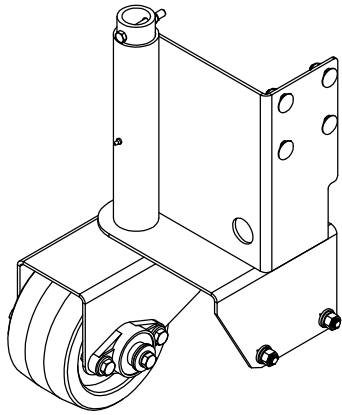
**AGRIMETAL****SWIVEL WHEEL (OPTION)**

CREATION : 12/01/18  
 REVISION : 15/01/18

ASSEMBLY : **32-57-1515**

AUTHOR : F.HÉLIE

Page 4 de 19

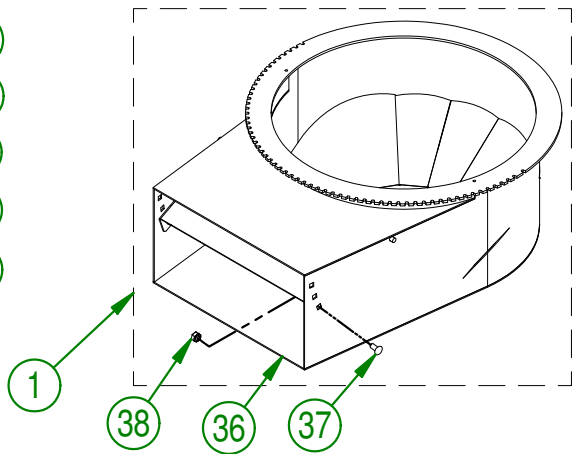
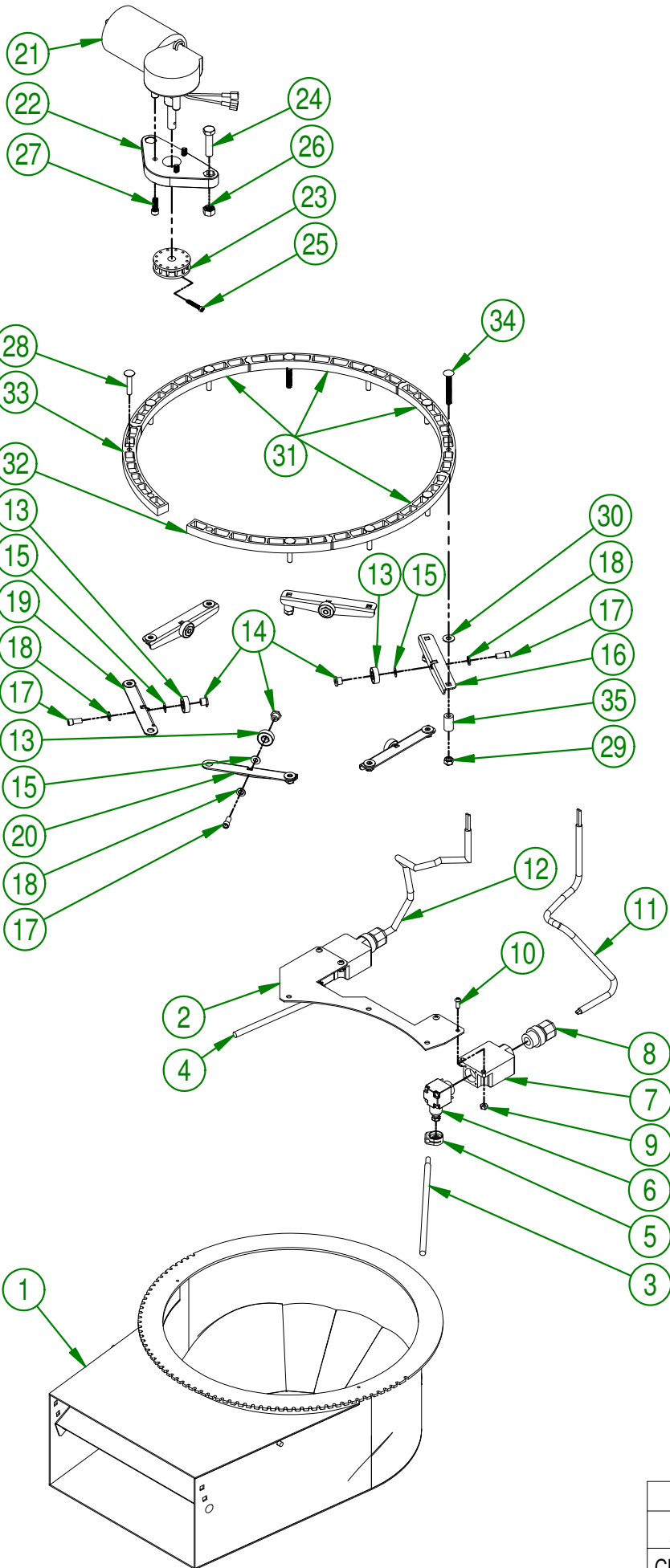

<b>AGRIMETAL</b>			
<b>ASSEMBLY 180° CHUTE</b>			
CREATION : 22-06-2016	ASSEMBLY :	32-57-4005	
REVISION : 04-02-2019	AUTHOR :	Page 5 de 19	

## 32-57-4005

#	PART #	Qty	TITLE
1	32-55-4004	1	ASSEMBLY DEFLECTOR
2	32-01-2552	1	MICRO SWITCH SUPPORT
3	32-21-0075	1	MICRO SWITCH ROD
4	32-21-0077	1	MICRO SWITCH ROD
5	NC13-25-0253	2	MICRO SWITCH ROD ADAPTOR
6	NC13-25-0252	2	MICRO SWITCH HEAD
7	NC13-25-0251	2	MICRO SWITCH BODY
8	NC13-25-0012	2	CONNECTOR "SKINTIGHT" (NYLON) 1/2 NPT X 0.200-0.470"
9	NC01-96-0006	4	NYLON NUT ZINC 10-24
10	NC02-40-0082	4	MACHINE SCREW PHILLIPS ZINC 10-24 OU 3/16"
11	32-55-4015	1	ELECT.BLACK CABLE 20" LG. (MICRO SWITCH)
12	32-55-4010	1	ELECT.BLACK CABLE 20" LG. (MICRO SWITCH)
13	NC14-75-0153	6	BALL BEARING R6 2RS 3/8" X 7/8" X 0.281"
14	33-25-2410	6	BEARING BUSHING
15	33-22-4605	6	BEARING SHIM 1/4" ALUMINUM
16	33-01-2425	4	BEARING HOLDER BRACKET
17	NC02-51-0578	6	SOCKET CAP SCREW T. RON. NF 1/4-28 X 1/2 STAINLESS
18	NC02-32-0010	6	LOCK WASHER ZINC 1/4"
19	32-01-2570	1	(LEFT) BEARING HOLDER BRACKET
20	32-01-2575	1	(RIGHT) BEARING HOLDER BRACKET
21	33-55-0046	1	DEFLECTOR ELECTRIC MOTOR
22	32-21-0205	1	ELECTIC MOTOR SUPPORT
23	33-55-0035	1	GEARED CROWN SPROCKET
24	NC01-17-0116	2	HEX. BOLT GR2 ZINC 3/8-16 X 1 1/2"
25	NC02-50-0069	1	SOCKET CAP SCREW T. RON 8-32 X 1"
26	NC01-93-0011	2	LOCK NUT 3/8-16
27	NC02-51-0580	3	STAINLESS STEEL SOCKET HEAD SCREW NF 1/4-28 X 3/4
28	NC01-04-0006	8	CARR. BOLT GR2 ZINC 1/4-20 X 1 1/4"
29	NC01-96-0009	10	NYLON-INSERT LOCKNUT ZINC 1/4-20
30	NC02-25-0007	7	WASHER ZINC 0.281 = 9/32
31	33-42-0100	4	PLASTIC GUIDE
32	33-42-0103	1	RIGHT PLASTIC GUIDE
33	33-42-0104	1	LEFT PLASTIC GUIDE
34	NC01-04-0009	2	CARRIAGE BOLT GR2 NC ZINC 1/4-20 X 2" LG.
35	33-21-0070	2	ACTUATOR SUPPORT BUSHING

## 32-55-4004

#	PART #	Qty	TITLE
36	32-50-4015	1	DEFLECTOR 180° (BW 2500 F-180 (JD & KUB)
37	NC01-04-0001	2	CARR. BOLT GR2 ZINC 1/4-20 X 1/2"
38	NC01-96-0009	2	NYLON-INSERT LOCKNUT ZINC 1/4-20

**AGRIMETAL****ASSEMBLY 180° CHUTE**

CREATION : 22-06-2016	ASSEMBLY :	32-57-4005
REVISION : 04-02-2019	AUTHOR :	

#	PART #	Qty	TITLE
1	32-46-0000	1	FRONT ROLLER
2	NC13-80-0061	4	PAD STEEL POWDER 1/2" X 5/8" X 3/8"
3	NC02-32-0014	4	LOCK WASHER ZINC 1/2"
4	NC02-07-0020	4	HEX. NUT ZINC 1/2-13
5	NC14-75-0020	2	FLANGE PILLOW BLOCK BEARING UCFL206-18 Ø 1 1/8"
6	NC01-04-0235	4	CARR. BOLT GR2 ZINC 1/2-13 X 1 1/2"

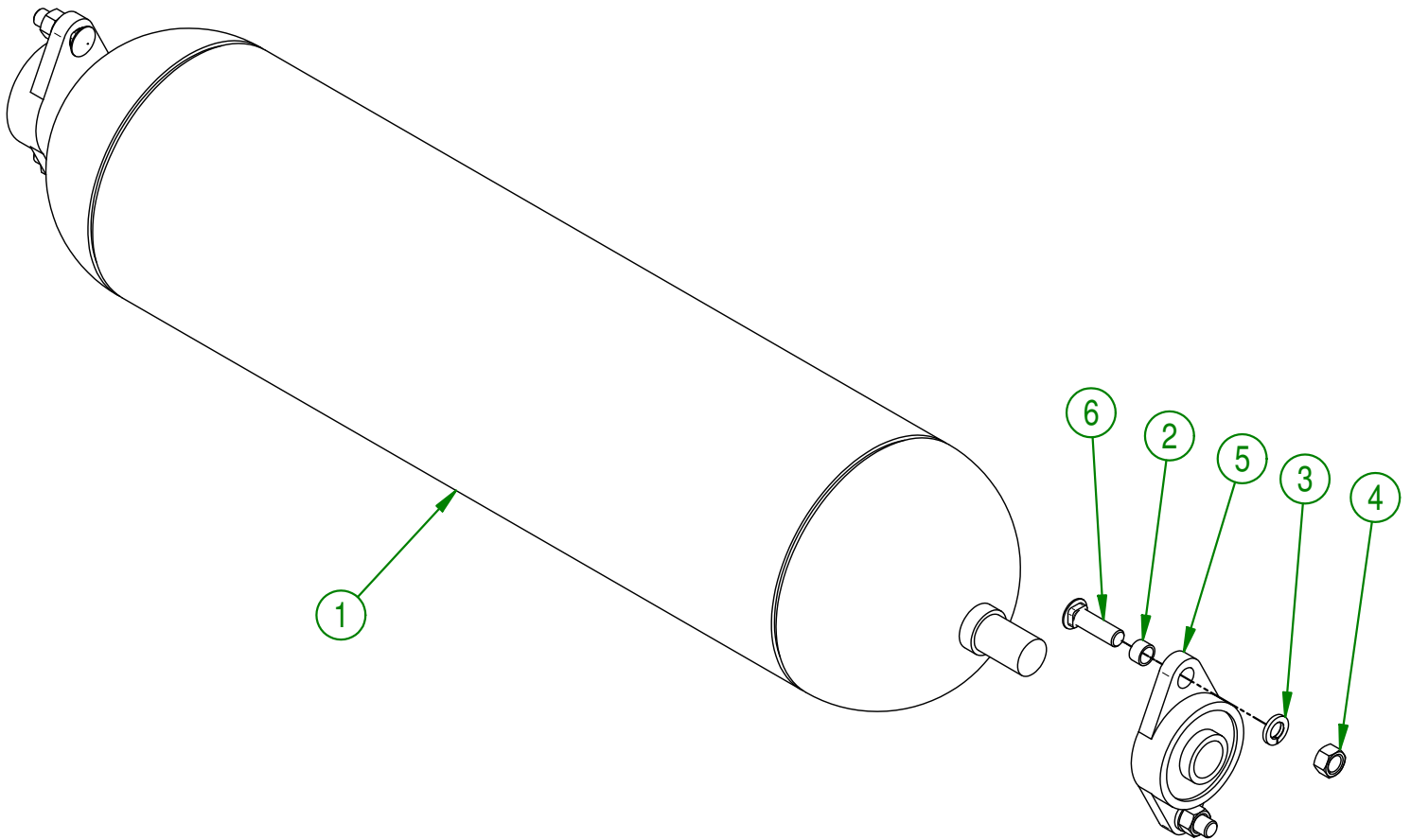

<b>AGRIMETAL</b>		
<b>ASSEMBLY LARGE TURF ROLLER</b>		
CREATION : 21-06-2016	ASSEMBLY :	32-57-3025
REVISION : 13-11-2018	AUTHOR : S.B.	Page 7 de 19



#	PART #	Qty	TITLE
1	32-07-0600	1	LEG STEEL TUBE
2	01-09-0105	2	WHEELS BUSHING
3	NC17-46-0006	2	WHEEL
4	NC02-32-0014	1	LOCK WASHER ZINC 1/2"
5	NC01-17-0263	1	BOLT HEX. GR2 ZINC 1/2-13 X 5"
6	NC02-07-0020	1	HEX. NUT ZINC 1/2-13
7	NC01-69-1200	1	QUICK PIN STAINLESS RING

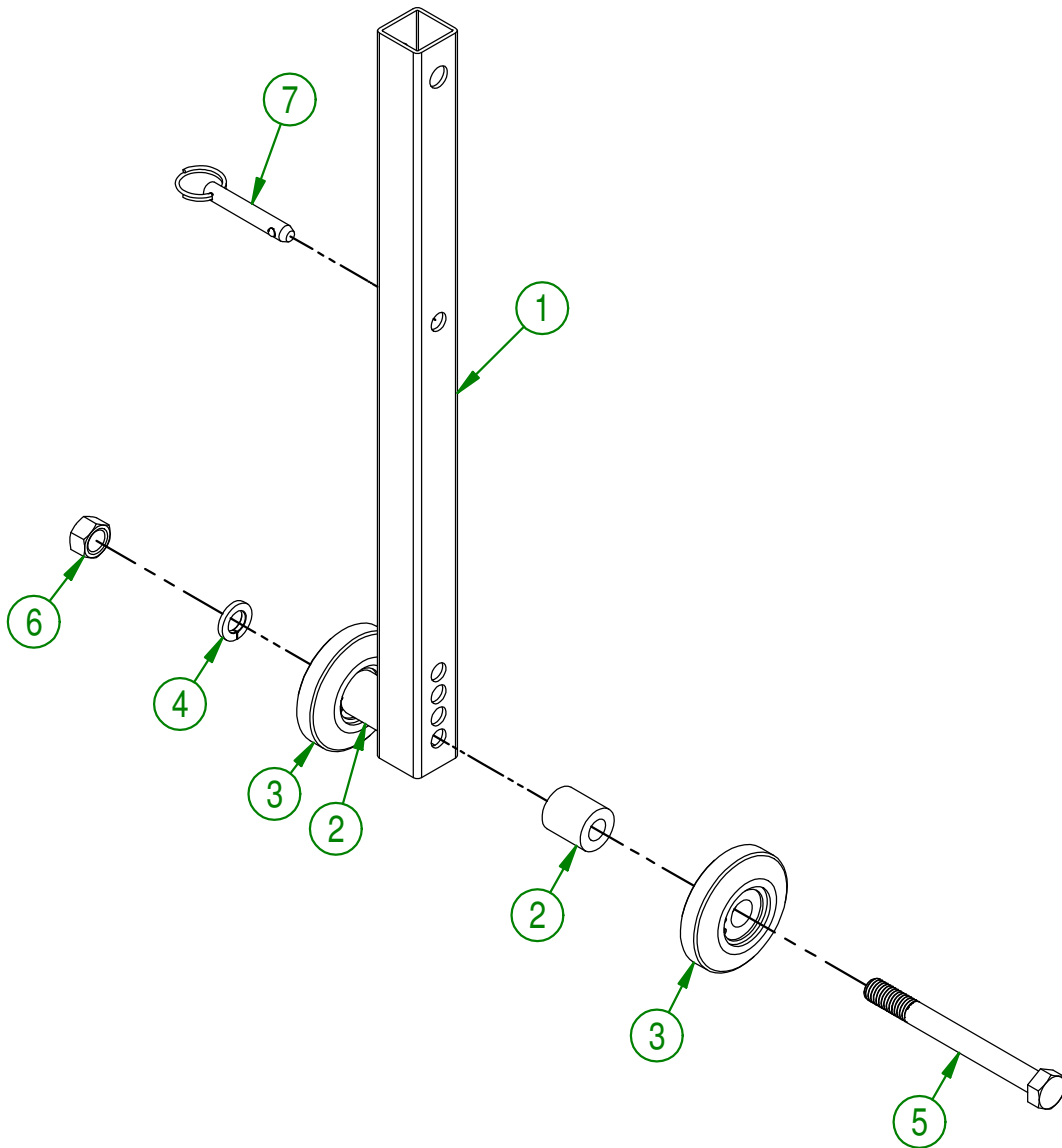

<b>AGRIMETAL</b>		
<b>ASSEMBLY LEG STAND</b>		
CREATION : 2016-06-23	ASSEMBLY :	32-57-4010
REVISION : 2018-01-12	AUTHOR : S.B.	Page 8 de 19

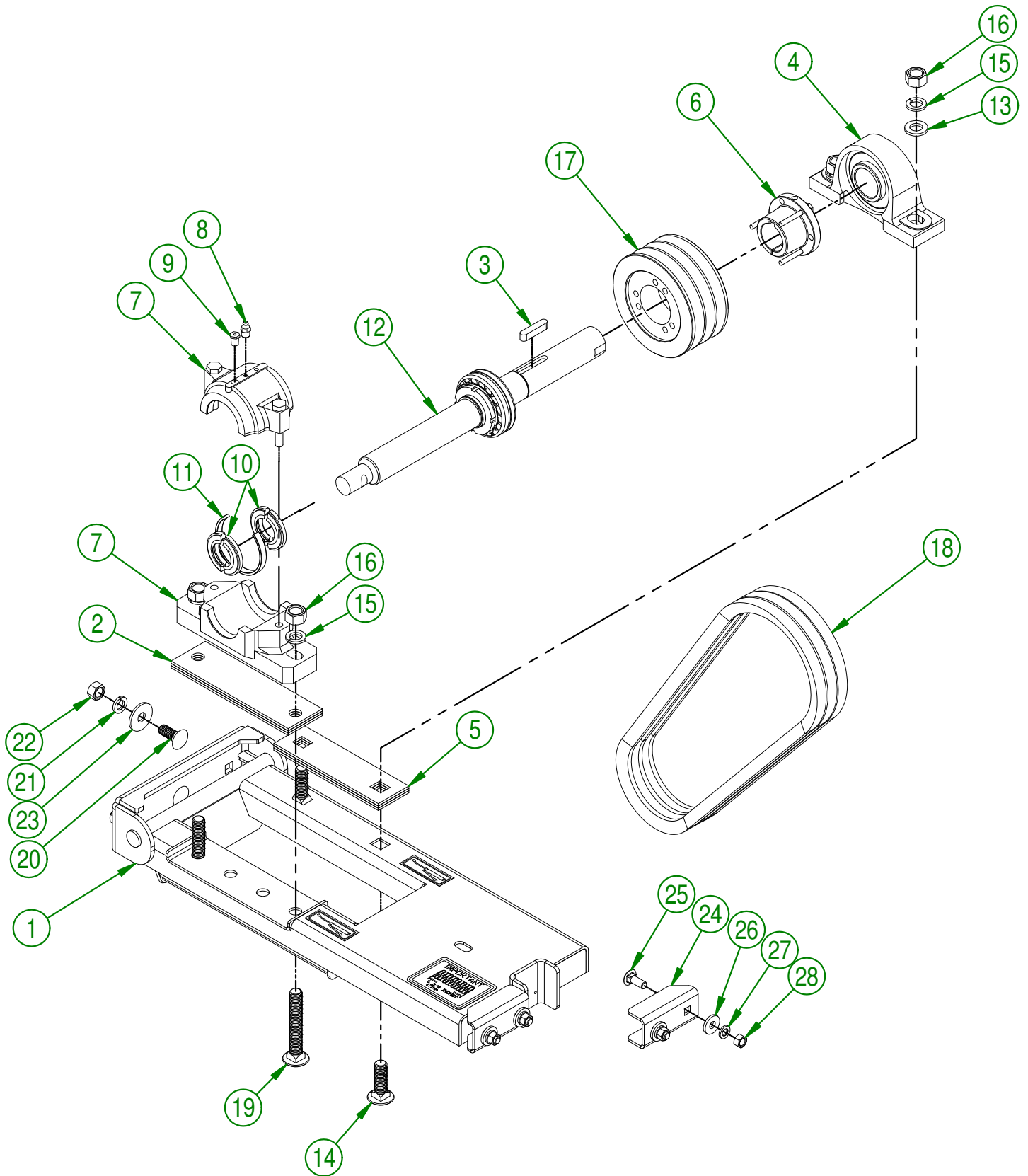

<b>AGRIMETAL</b>			
<b>BEARING BASE GROUP</b>			
CREATION : 23-06-2016	ASSEMBLY :	32-57-4015	
REVISION : 21-09-2018	AUTHOR : S.B.	Page 9 de 19	

#	PART #	Qty	TITLE
1	32-57-3520	1	ASSEMBLY BEARING BASE "STICKER INCLUDED"
2	32-03-6000	3	BEARING SHIM
3	NC01-65-0100	1	KEY 3/8 X 3/8 X 1 3/4"
4	NC14-75-0035	1	PILLOW BLOCK SUPPORT UCP208-24 $\phi$ 1 1/2"
5	32-03-6005	3	BEARING SHIM
6	NC14-62-0007	1	QD BUSHING SD 1 1/2"
7	NC14-75-0131	1	PILLOW BLOCK CASING
8	NC01-69-0791	1	GREASE FITTING 1/8 NPT STRAIGHT
9	32-45-0000	1	BEARING PLUG
10	NC14-75-0130	1	SET JOINT 1 1/2"
11	NC14-75-0129	1	BEARING SHIM 1 1/2"
12	32-55-3563	1	ASSEMBLY DRIVE SHAFT
13	32-01-1395	2	BEARING WHASER $\phi$ 3/4"
14	NC01-04-0268	2	BOLT CARR. GR2 ZINC 5/8-11 X 2"
15	NC02-32-0016	4	LOCK WASHER ZINC 5/8"
16	NC02-07-0022	4	HEX. NUT ZINC 5/8-11
17	NC14-62-0217	1	PULLEY QD 3VI/2-5/8 X 6.55 OD X SD
18	NC14-25-1084	3	V BELT 21/32 COGGED RAW EDGE BX-45
19	NC01-04-0276	2	BOLT CARR. GR2 ZINC 5/8-11 X 4"
20	NC01-04-0234	3	CARR. BOLT GR2 ZINC 1/2-13 X 1 1/4
21	NC02-32-0014	3	LOCK WASHER ZINC 1/2"
22	NC02-07-0020	3	HEX. NUT ZINC 1/2-13
23	01-01-1660	3	WASHER SPACER
24	32-01-1125	2	BEARING BASE STOPPER
25	NC01-04-0109	4	CARR. BOLT GR2 ZINC 3/8-16 X 1"
26	21-01-0950	4	FLAT WASHER IOGA 1.005" DIA X 25/64"
27	NC02-32-0012	4	LOCK WASHER ZINC 3/8"
28	NC02-07-0018	4	HEX. NUT ZINC 3/8-16

**AGRIMETAL****BEARING BASE GROUP**

CREATION : 23-06-2016	ASSEMBLY :	32-57-4015
REVISION : 21-09-2018	AUTHOR : S.B.	Page 10 de 19

#	PART #	Qty	TITLE
1	NC17-46-0018	2	HANDLE KNOB
2	NC01-17-0119	2	HEX. BOLT GR2 ZINC 3/8-16 X 2 1/4"
3	01-01-2485	6	FLAT WASHER
4	NC02-32-0012	6	LOCK WASHER ZINC 3/8"
5	NC02-07-0018	2	HEX. NUT ZINC 3/8-16
6	NC13-15-0080	1	BLACK RUBBER SN60 3/16" X 12" X 15 7/8"
7	16-01-2720	9	WASHER 13/16" DIA. X 13/64"
8	NC01-78-0016	9	ALUMINIUM BLIND POP RIVET STEEL MANDREL 0.187 X 0.690
9	32-57-4120	1	ASSEMBLY BELT COVER
10	NC01-17-0112	4	HEX. BOLT GR2 ZINC 3/8-16 X 3/4"
11	NC01-04-0055	2	CARR. BOLT GR2 ZINC 5/16-18 X 5/8"
12	NC01-96-0010	2	NYLON NUT HEX. ZINC 5/16-18

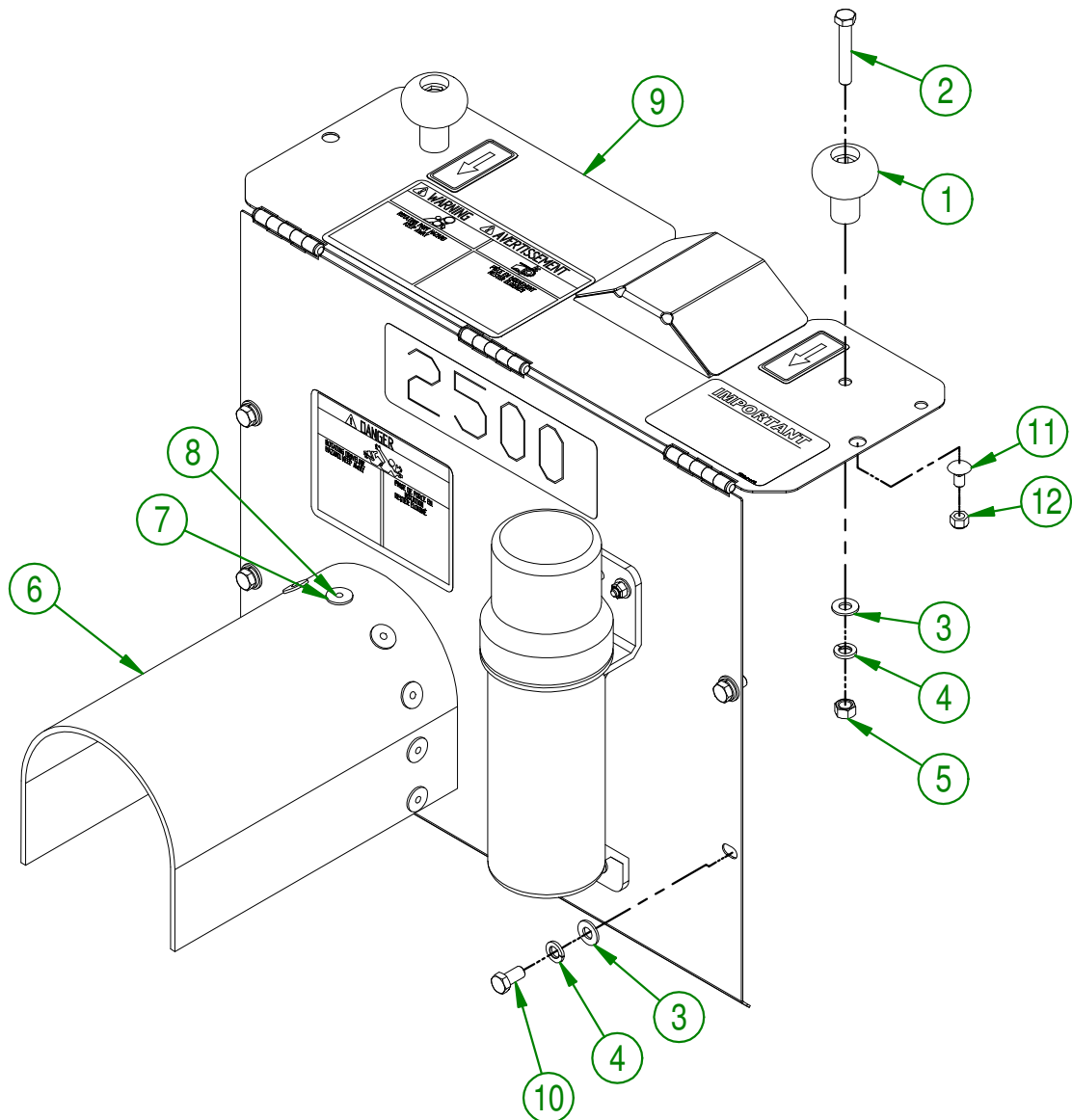
**AGRIMETAL****ASSEMBLY BELT COVER**

CREATION : 2016-06-21

ASSEMBLY :

32-57-3585

REVISION : 2018-03-06

AUTHOR : S.B.

Page 11 de 19

#	PART #	Qty	TITLE
1	32-50-3530	1	WELD ASSEMBLY THREADED ROD
2	NC02-25-0011	1	WASHER SAE ZINC 17/32 ID
3	32-42-0115	1	SPRING GUIDE
4	NC13-86-0083	1	BLUE SPRING 1/2" ID X 1" OD X 4"
5	32-42-0140	1	SPRING STOPPER
6	NC02-07-0020	2	HEX. NUT ZINC 1/2-13
7	32-01-3075	1	HANDLE

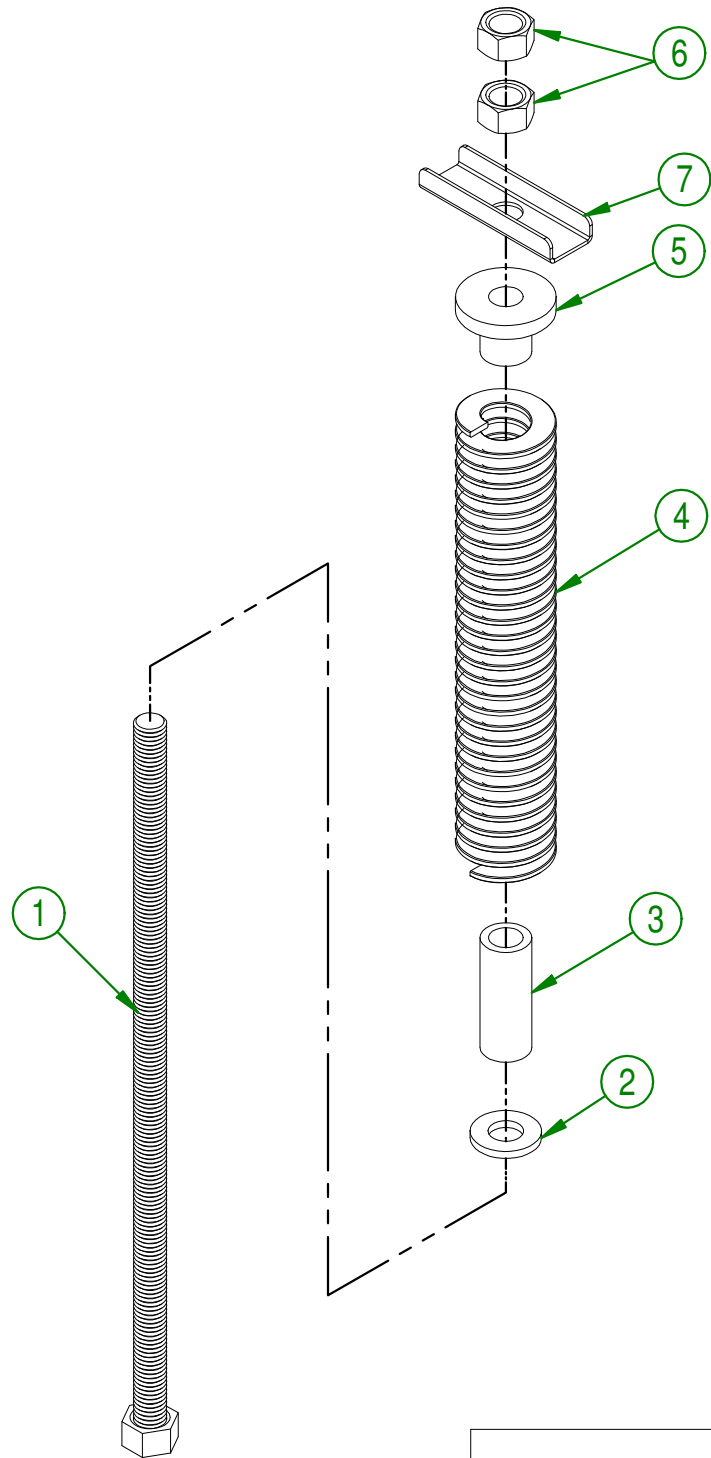

<b>AGRIMETAL</b>	
<b>ASSEMBLY BELT TENSIONER</b>	
CREATION : 2016-06-21	ASSEMBLY : 32-57-3540
REVISION : 2018-01-12	AUTHOR : S.B. Page 12 de 19

#	# DE PIÈCE	Qty	TITLE
1	32-50-3040	1	WELD ASSEMBLY BRACKET BELT COVER
2	NC01-04-0107	2	CARR. BOLT GR2 ZINC 3/8-16 X 3/4"
3	NC02-32-0012	2	LOCK WASHER ZINC 3/8"
4	NC02-07-0018	2	HEX. NUT ZINC 3/8-16

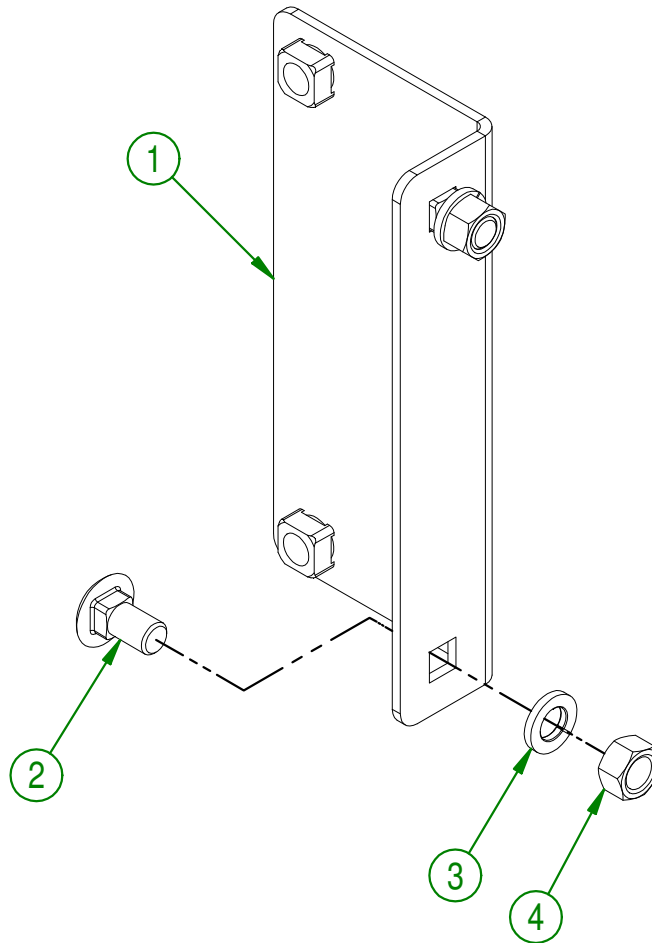

<b>AGRIMETAL</b>	
<b>ASSEMBLY BRACKET BELT COVER</b>	
CREATION : 2016-06-21	ASSEMBLY : 32-57-3055
REVISION : 2018-01-12	AUTHOR : S.B. Page 13 de 19

#	PART #	Qty	TITLE
1	NC17-94-0008	1	IMPELLER SHAFT
2	NC14-75-0025	1	FLANGE BEARING 4 HOLES UCF 208-24 X 1 1/2"
3	NC01-17-0396	4	HEX. BOLT GR2 ZINC 5/8-11 X 2"
4	NC02-32-0016	4	LOCK WASHER ZINC 5/8"
5	NC02-07-0022	4	HEX. NUT ZINC 5/8-11
6	32-09-2000	3	IMPELLER SPACER
7	NC14-75-0024	1	FLANGE BEARING 4 HOLES UCF207-20 1 1/4" DIA.
8	12-01-3051	1	REAR BEARING PROTECTOR
9	NC01-17-0250	4	HEX. BOLT GR2 ZINC 1/2-13 X 1 3/4"
10	NC02-25-0011	4	WASHER SAE ZINC 17/32 ID
11	NC02-32-0014	4	LOCK WASHER ZINC 1/2"
12	NC02-07-0020	4	HEX. NUT ZINC 1/2-13
13	32-55-3050	1	IMPELLER
14	NC01-98-0022	1	NYLON NUT HEX. 1 3/8-12 THIN
15	NC14-62-0202	1	PULLEY QD 3VI/2-5/8 X 7.35 OD X SK (3B70)
16	NC14-62-0021	1	QD BUSHING SK 1 1/2"
17	32-41-0900	1	IMPELLER KEY
18	12-41-0915	1	PULLEY KEY

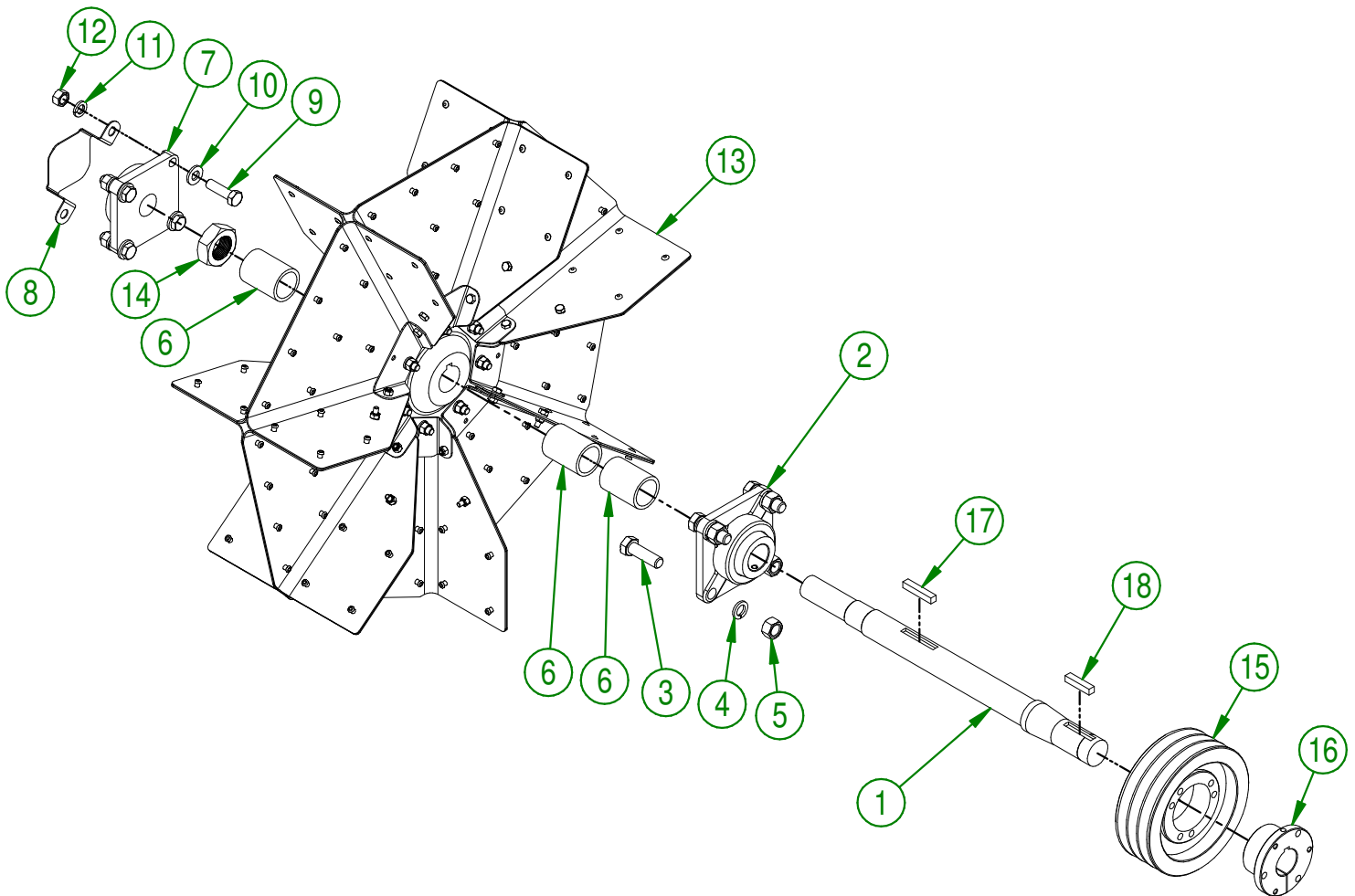

USE THESE PIECES ONLY IF YOUR SERIAL  
NUMBER IS AFFECTED:

#39750 AND UNDER

AGRIMETAL	
ASSEMBLY IMPELLER	
CREATION : 2016-06-21	ASSEMBLY : 32-57-3545
REVISION : 2021-02-15	AUTHOR : S.B.

32-57-3546

#	PART #	Qty	TITLE
1	NC14-75-0025	1	FLANGE BEARING 4 HOLES UCF 208-24 X 1 1/2"
2	NC01-17-0396	4	HEX. BOLT GR2 ZINC 5/8-11 X 2"
3	NC02-32-0016	4	LOCK WASHER ZINC 5/8"
4	NC02-07-0022	4	HEX. NUT ZINC 5/8-11
5	NC14-75-0024	1	FLANGE BEARING 4 HOLES UCF207-20 1 1/4" DIA.
6	12-01-3051	1	REAR BEARING PROTECTOR
7	NC01-17-0250	4	HEX. BOLT GR2 ZINC 1/2-13 X 1 3/4"
8	NC02-25-0011	4	WASHER SAE ZINC 17/32 ID
9	NC02-32-0014	4	LOCK WASHER ZINC 1/2"
10	NC02-07-0020	4	HEX. NUT ZINC 1/2-13
11	32-57-6000	1	IMPELLER
12	NC14-62-0202	1	PULLEY QD 3VI/2-5/8 X 7.35 OD X SK (3B70)
13	NC14-62-0021	1	QD BUSHING SK 1 1/2"
14	12-41-0915	1	PULLEY KEY

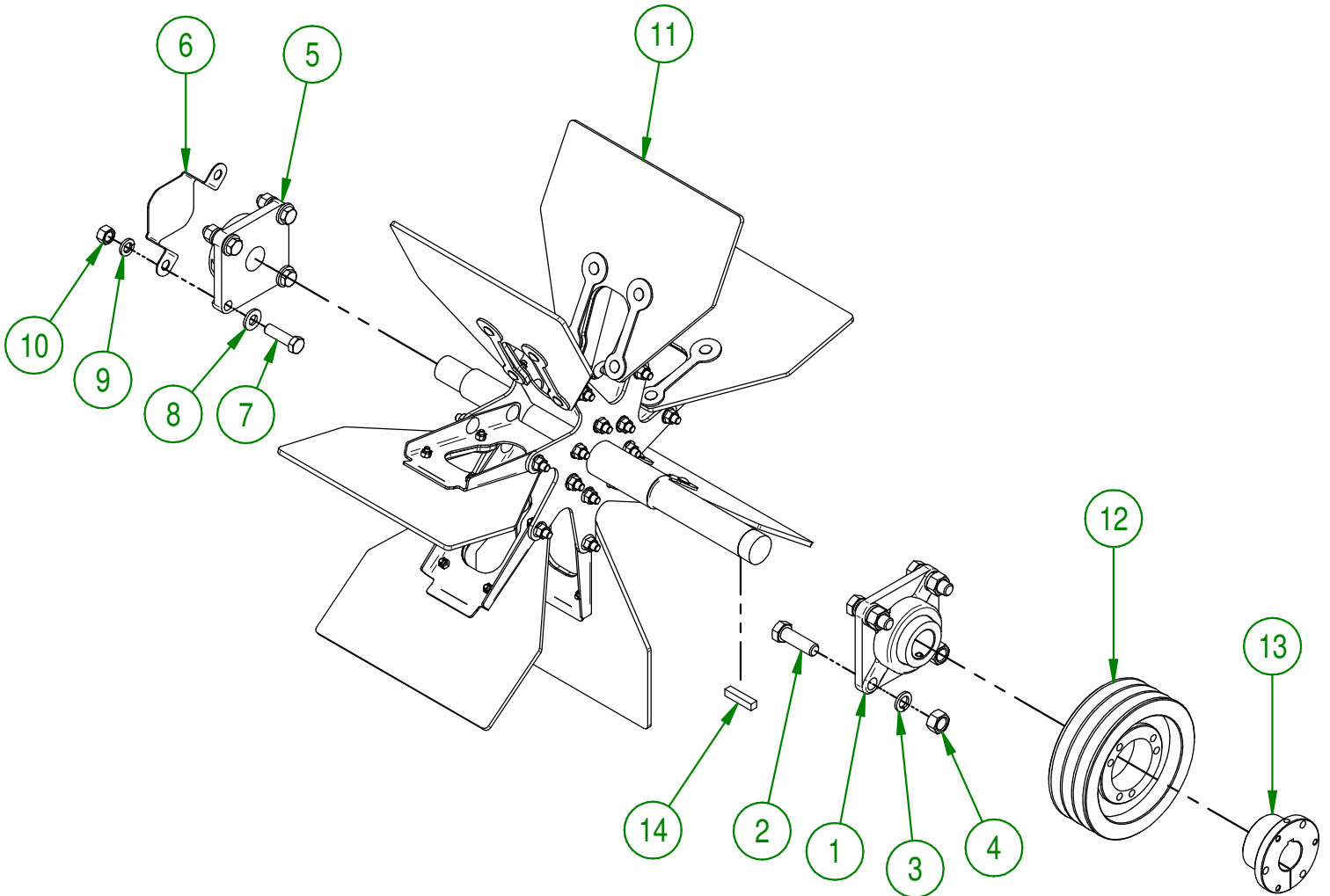

USE THESE PIECES ONLY IF YOUR SERIAL NUMBER IS AFFECTED:

#39751 AND ABOVE

**AGRIMETAL**  
**ASSEMBLY IMPELLER**

CREATION : 15/02/21  
REVISION : 15/02/21

ASSEMBLY : **32-57-3546**  
AUTHOR : J. Houle



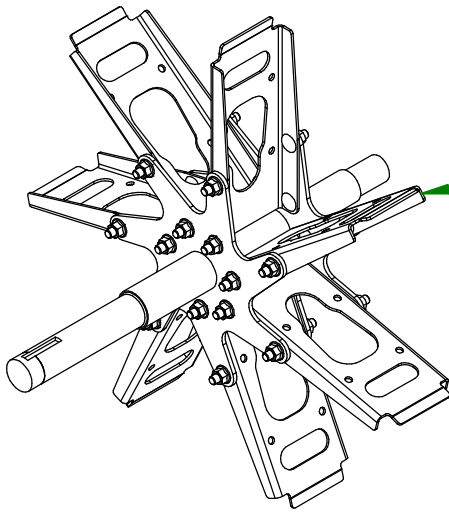

32-50-6000  
IMPELLER FRAME

32-57-6010  
IMPELLER PADDLE AND PADDLE REINFORCEMENT GROUP

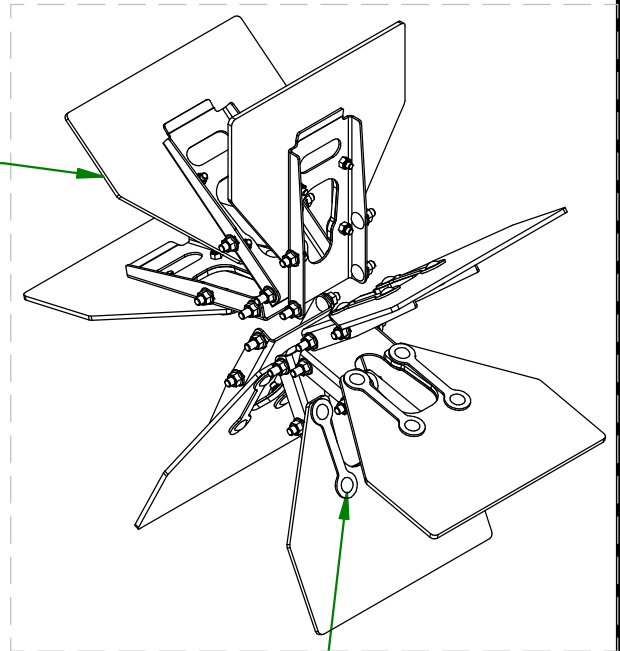

TORQUE AT  
120 INCH POUNDS

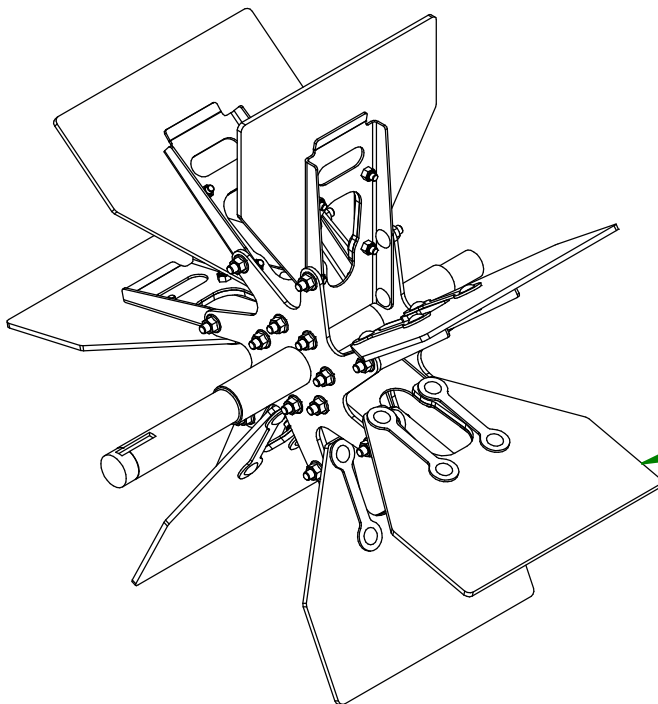

32-57-6000  
IMPELLER

**AGRIMETAL**  
**IMPELLER**

CREATION : 06/10/20  
REVISION : 16/09/22

ASSEMBLY : **32-57-6000**  
AUTHOR : J. Houle

32-57-4050

#	PART #	Qty	TITLE
1	32-57-4055	1	ASSEMBLY COVER CASING
2	NC01-04-0107	8	CARR. BOLT GR2 ZINC 3/8-16 X 3/4"
3	NC02-14-0019	10	FLANGE NUT HEX. NC 3/8-16 GR. B

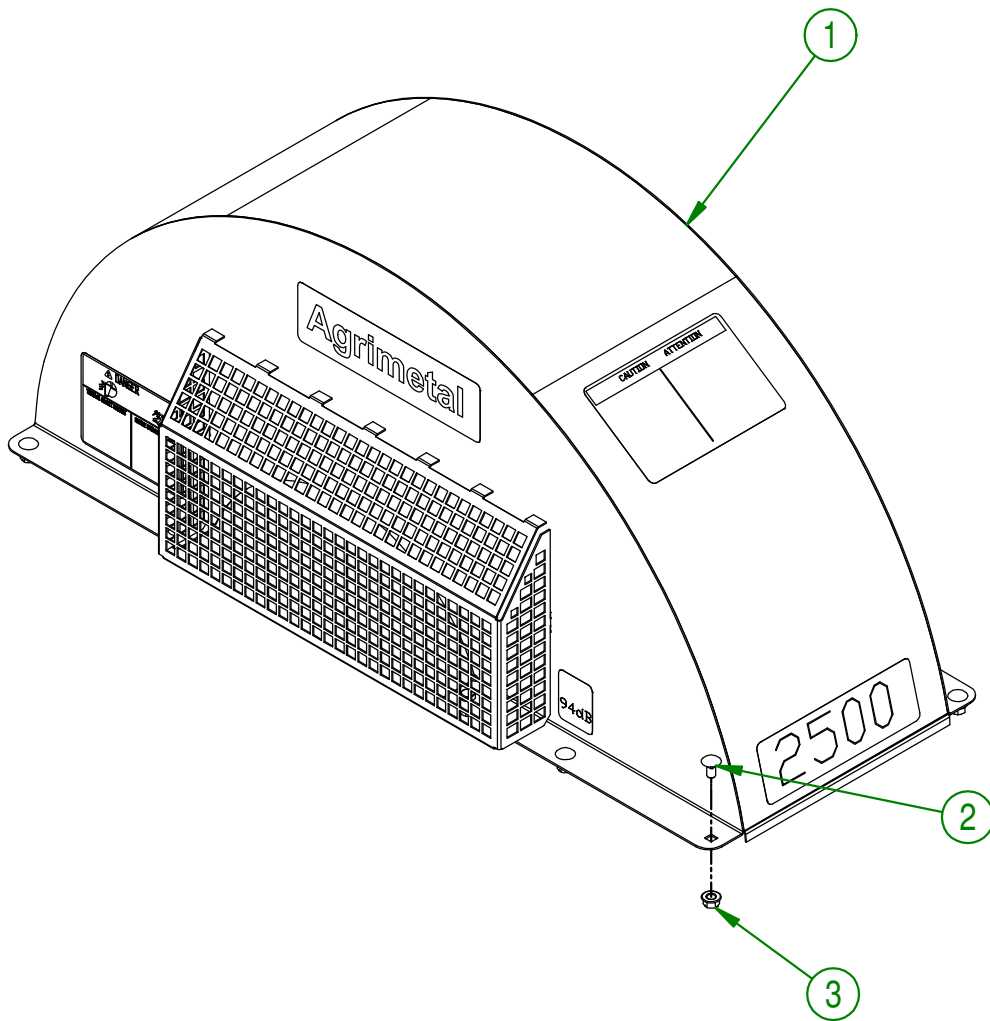

<b>AGRIMETAL</b>			
<b>ASSEMBLY CASING COVER</b>			
CREATION : 2016-06-23	ASSEMBLY :	32-57-4050	
REVISION : 2018-02-01	AUTHOR : S.B.	Page 15 de 19	

#	PART #	Qty	TITLE
1	NCI3-30-0237	1	PLASTIC TUBE FOR OPERATOR'S MANUAL
2	32-98-0530	1	OPERATOR MANUEL
3	NC01-04-0003	3	BOLT CARR. GR2 ZINC 1/4-20 X 3/4"
4	NC02-25-0007	3	WASHER ZINC 0.281 = 9/32
5	NC01-96-0009	3	NYLON-INSERT LOCKNUT ZINC 1/4-20
6	NCI3-25-0019	1	BLACK TIE RAP
7	NCI3-25-0287	1	18-14 GA BLUE CONNECTOR

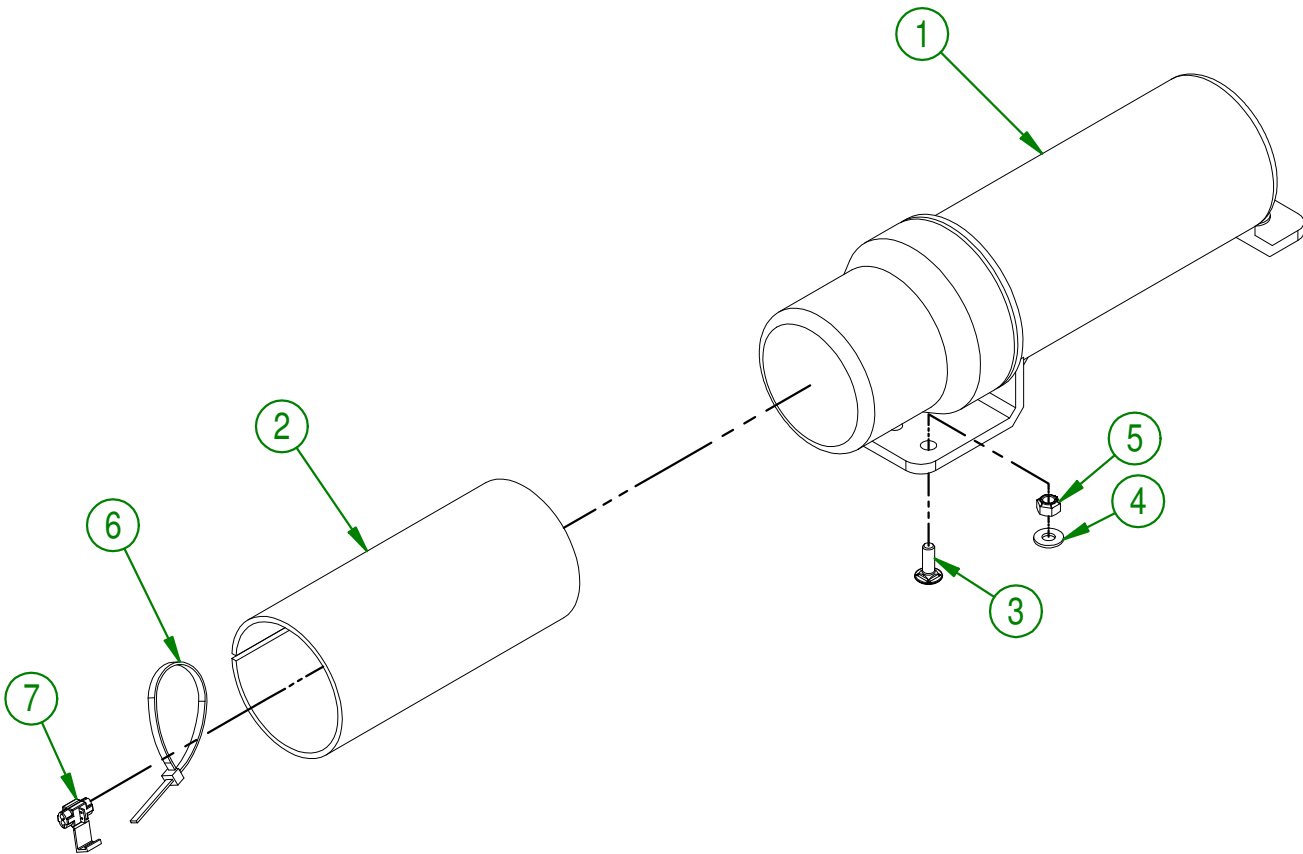

**AGRIMETAL**  
**OPERATOR MANUAL**

CREATION : 13/02/17  
 REVISION : 01/02/18

ASSEMBLY : **32-57-4110**

AUTHOR : F.HÉLIE Page 16 de 19

#	PART #	Qty	TITLE
1	32-01-2555	1	SWITCH BRACKET
2	NC13-25-0284	1	KRALOY TERMINAL BOX 2" X 2 13/16" X 4 9/16"
3	NC13-25-0285	1	KRALOY BOX COVER 2 13/16" X 4 9/16"
4	32-21-0070	2	TERMINAL BOX BUSHING
5	NC01-17-0008	2	HEX. BOLT GR2 ZINC 1/4-20 X 1 1/2"
6	NC02-25-0007	2	WASHER ZINC 0.281 = 9/32
7	NC01-96-0009	2	NYLON-INSERT LOCKNUT ZINC 1/4-20
8	NC13-25-0019	4	BLACK TIE RAP
9	NC14-35-0234	1	TELESCOPIC MOTOR SWITCH
10	32-55-4020	1	ELECT. BLACK CABLE 38 1/2" (12V MOTOR) ASSEMBLY
11	NC13-25-0027	2	SAFE WIRE CONNECTOR NUMBER 31
12	32-55-4035	1	4 CONTACTS FLAT CONNECTOR (AUTO) X 52" ASSEMBLY
13	NC13-25-0028	2	SAFE WIRE CONNECTOR NUMBER 31
14	32-46-0100	1	4 CONTACTS FLAT CONNECTOR (TRAILER) 36"

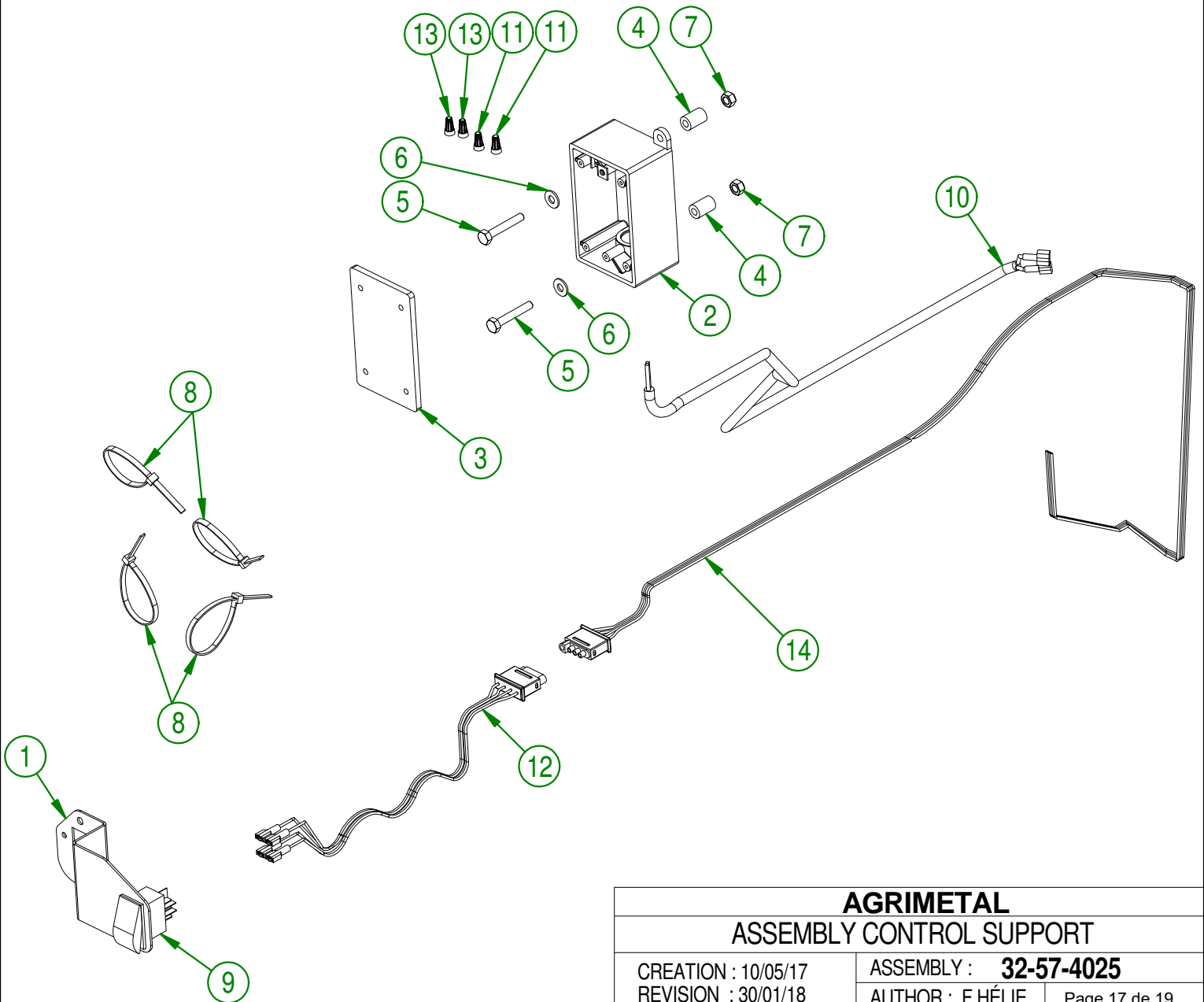

<b>AGRIMETAL</b>	
<b>ASSEMBLY CONTROL SUPPORT</b>	
CREATION : 10/05/17	ASSEMBLY : <b>32-57-4025</b>
REVISION : 30/01/18	AUTHOR : F.HÉLIE Page 17 de 19

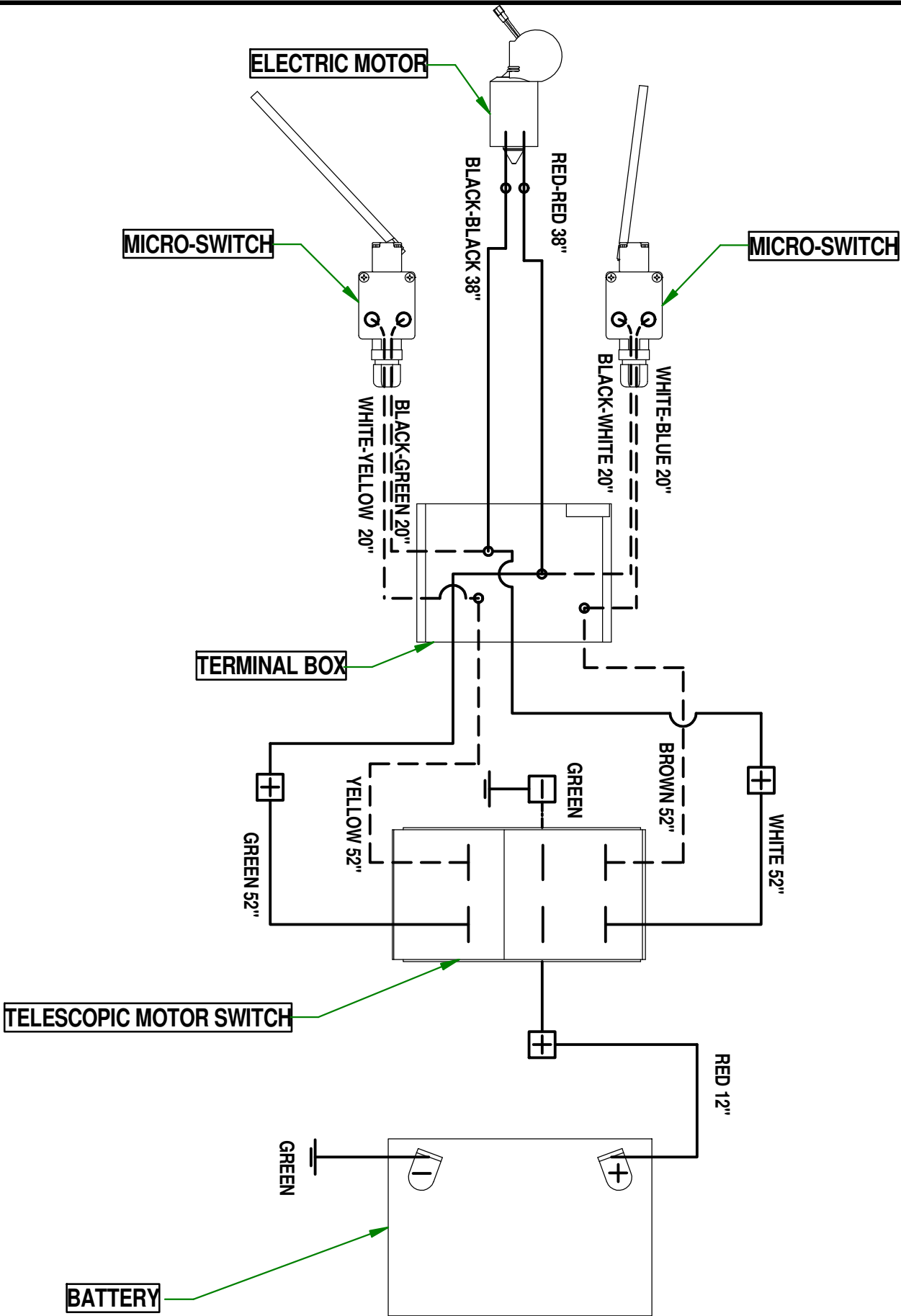

# ELECTRIC DIAGRAM 32-99-1510

#	PART #	QTY	TITLE
1	NCI3-33-0024	6	STICKER GREASE HERE
2	NCI3-33-0163	1	STICKER LOW DECIBEL
3	NCI3-33-0113	1	STICKER WARNING
4	NCI3-33-0112	1	STICKER DANGER
5	NCI3-33-0110	2	STICKER DANGER
6	NCI3-33-0154	1	STICKER IMPORTANT
7	NCI3-33-0156	1	STICKER CAUTION
8	NCI3-33-0158	3	STICKER 2500
9	NCI3-33-0169	1	STICKER 94 DB
10	NCI3-33-0035	2	STICKER AGRIMETAL
11	NCI3-33-0018	1	STICKER WARNING
12	NCI3-33-0218	1	STICKER DANGER
13	NCI3-33-0179	1	STICKER IMPORTANT GREASE DRIVE LINE
14	NCI3-33-0298	2	STICKER PULL THIS WAY TO OPEN

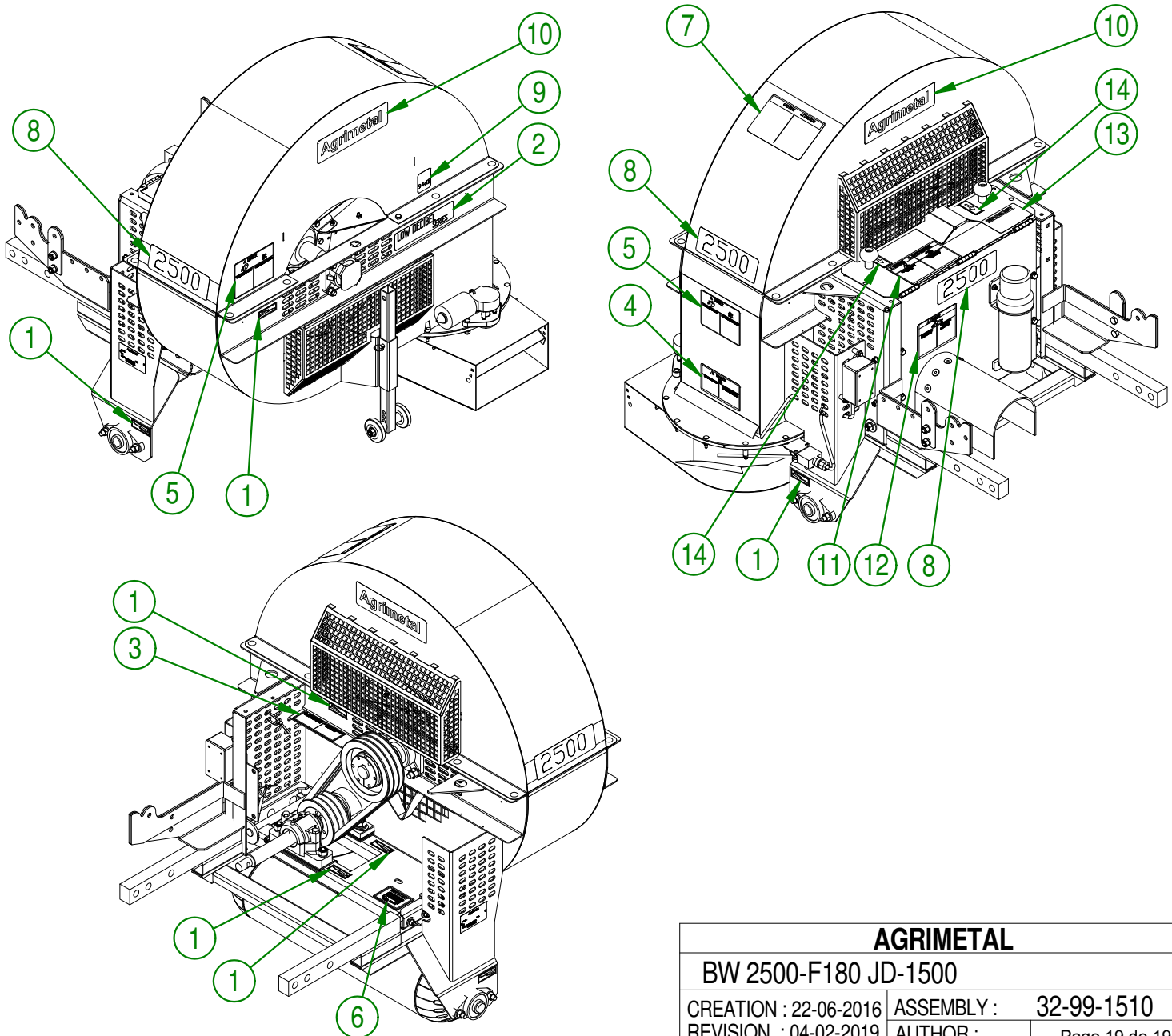

<b>AGRIMETAL</b>		
<b>BW 2500-F180 JD-1500</b>		
CREATION : 22-06-2016	ASSEMBLY :	32-99-1510
REVISION : 04-02-2019	AUTHOR :	Page 19 de 19