

# AgriMetal

## PARTS LIST

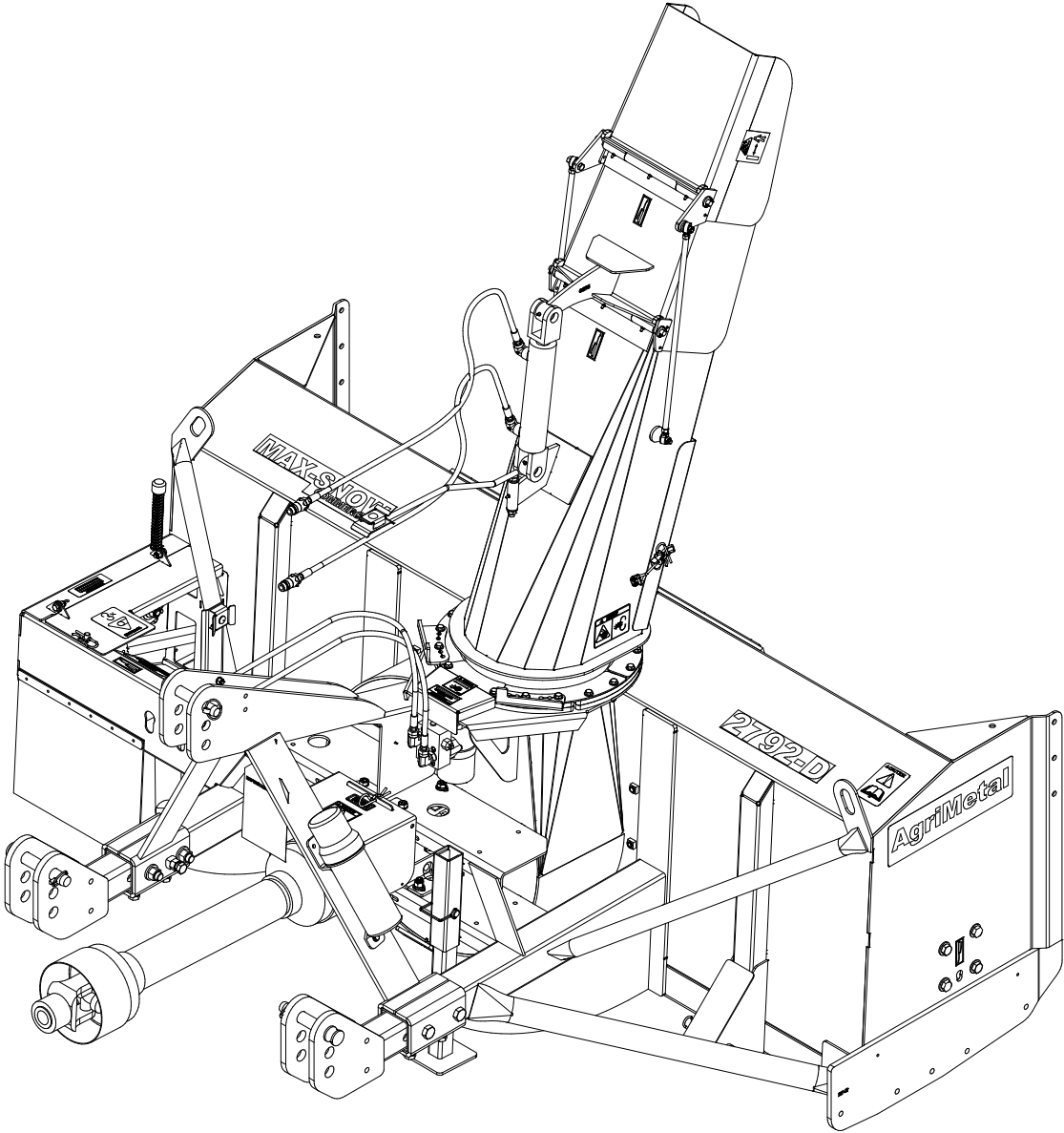

**MS 2792-D**

81-57-0705

#	PART #	Qty	TITLE
1	81-50-0700	2	KNIFE BRACE (TOP)
2	81-42-0105	1	RIGHT KNIFE (UHMW)
3	81-42-0106	1	LEFT KNIFE (UHMW)
4	81-04-0350	2	KNIFE BRACE (UNDER)
5	NC02-48-0564	10	FLAT HEAD SOCKET CAP SCREW STAINLESS 5/8-11 X 2" LG
6	NC01-93-0016	10	LOCK NUT ZINC 5/8-11
7	81-42-0103	1	LATERAL KNIFE (RIGHT)
8	81-42-0104	1	LATERAL KNIFE (LEFT)
9	NC02-25-0011	4	WASHER SAE ZINC 17/32 ID
10	80-04-0185	6	WASHER
11	NC01-17-0394	6	HEX. BOLT GR2 ZINC 5/8-11 X 1 1/2"
12	NC01-17-0250	2	HEX. BOLT GR2 ZINC 1/2-13 X 1 3/4"
13	NC01-17-0251	2	HEX. BOLT GR2 ZINC 1/2-13 X 2"
14	NC01-93-0014	4	LOCK NUT ZINC 1/2-13

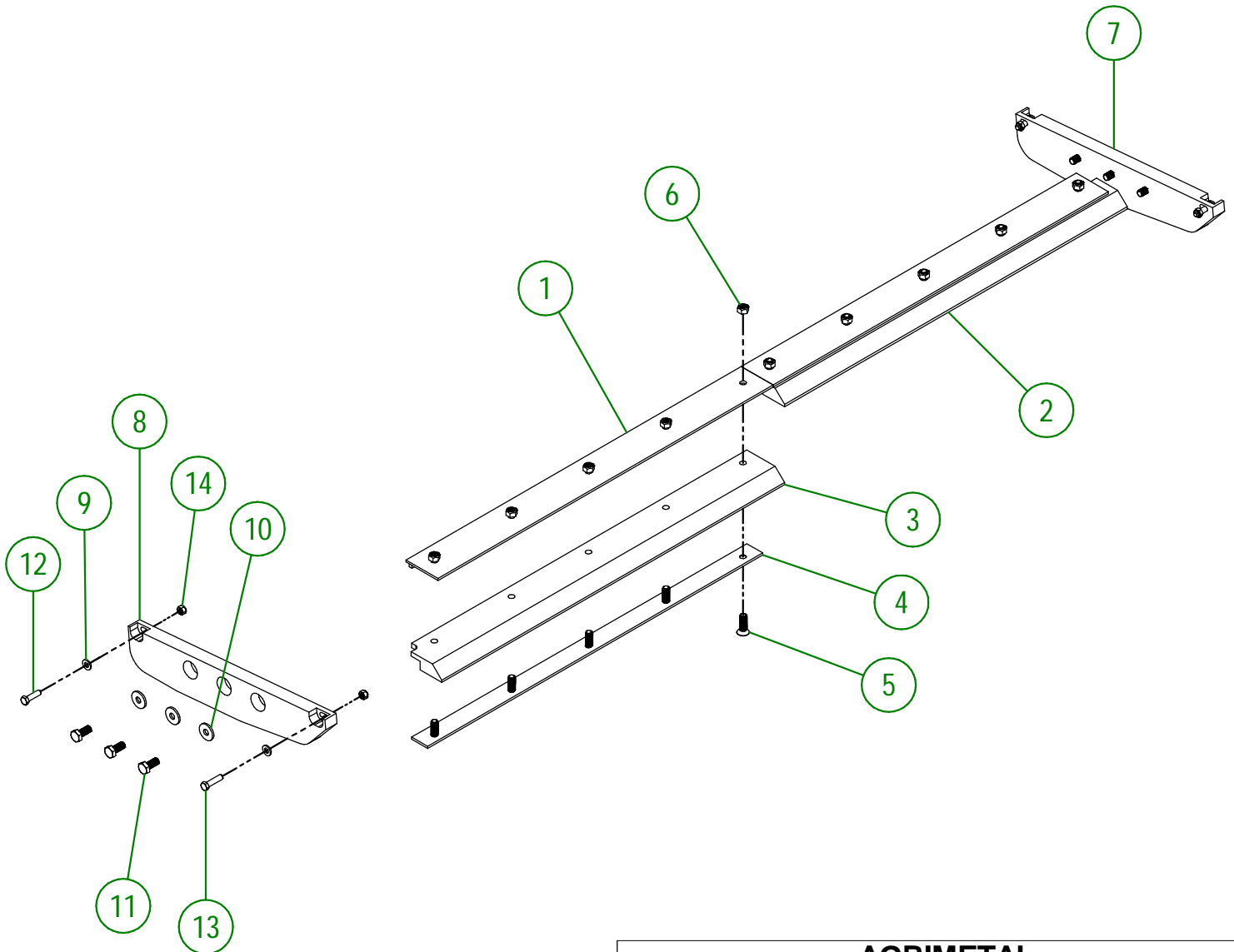

<b>AGRIMETAL</b>	
<b>SET OF KNIVES (UHMW)</b>	
CREATION : 19/07/16	ASSEMBLY : <b>81-57-0705</b>
REVISION : 27/09/23	AUTHOR : J. HOULE

81-57-0700

#	PART #	Qty	TITLE
1	80-50-0085	2	LATERAL SKATE (#450 HARDNESS STEEL)
2	81-50-0055	2	ADJUSTABLE SKATE (#450 HARDNESS STEEL)
3	NC02-48-0586	4	FLAT HEAD SOCKET CAP SCREW 5/8-11 X 1" LG
4	81-57-0230	2	KNIFE (#450 HARDNESS STEEL) GROUP (BOLTS AND NUTS INCLUDED)

81-57-0230

#	PART #	Qty	TITLE
5	NC01-93-0016	5	LOCK NUT ZINC 5/8-11
6	NC01-09-0039	5	PLOW BOLT GR5 5/8-11 X 1 1/2" LG

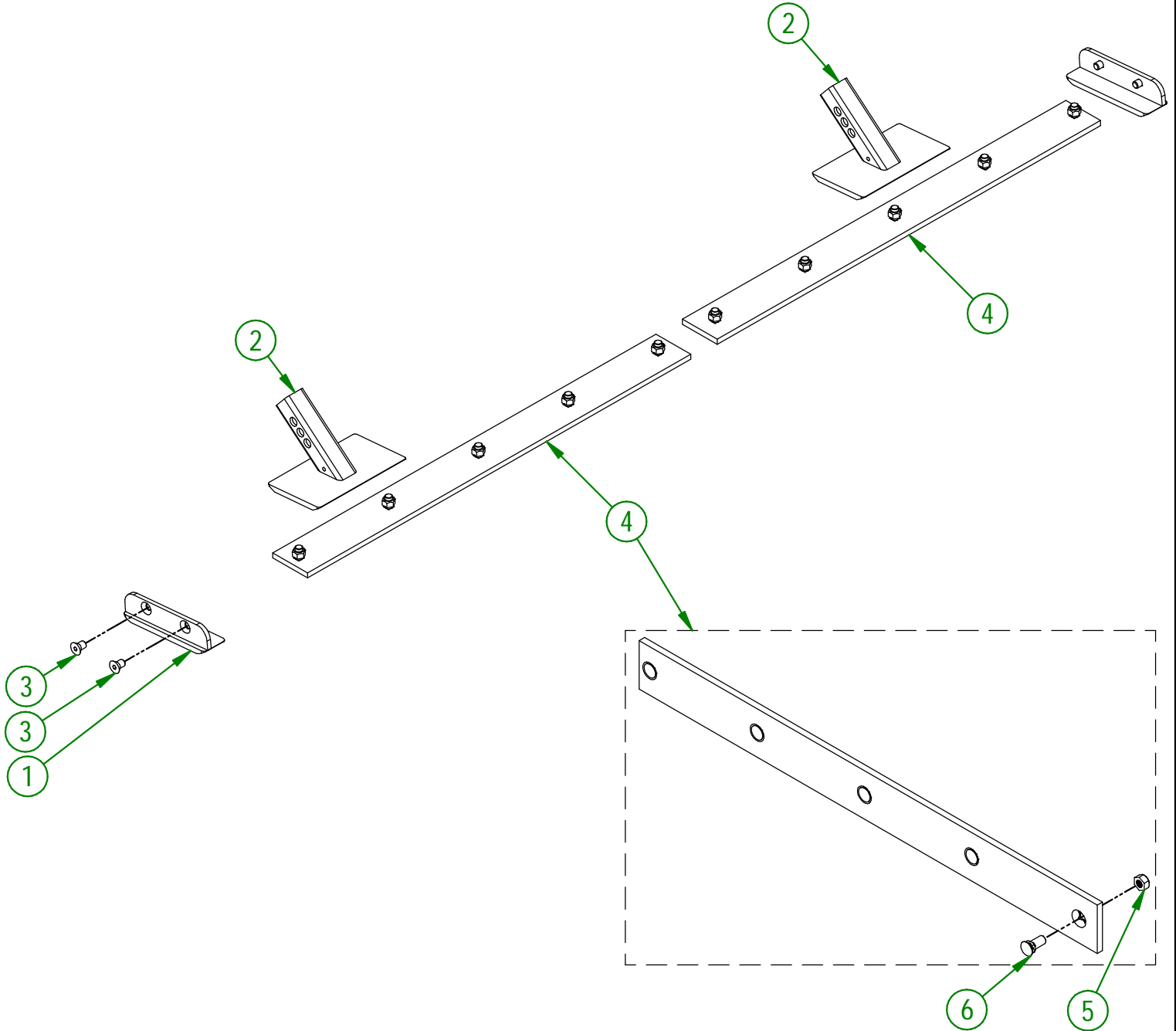

**AGRIMETAL**

**SET OF KNIVES (#450 HARDNESS STEEL)**

CREATION : 19/07/16  
REVISION : 26/09/23

ASSEMBLY : **81-57-0700**  
AUTHOR : Dessin2

81-57-0710

#	PART #	Qty	TITLE
1	NC02-48-0586	4	FLAT HEAD SOCKET CAP SCREW 5/8-11 X 1" LG
2	80-50-0087	2	LATERAL SKATE (STAINLESS STEEL)
3	81-50-0058	2	ADJUSTABLE SKATE (STAINLESS STEEL)
4	81-57-0235	2	KNIFE (STAINLESS STEEL) GROUP (BOLTS AND NUTS INCLUDED)

81-57-0235

#	PART #	Qty	TITLE
5	NC02-48-0562	5	FLAT HEAD SOCKET CAP SCREW STAINLESS 5/8-11 X 1 1/2"
6	NC01-93-0016	5	LOCK NUT ZINC 5/8-11

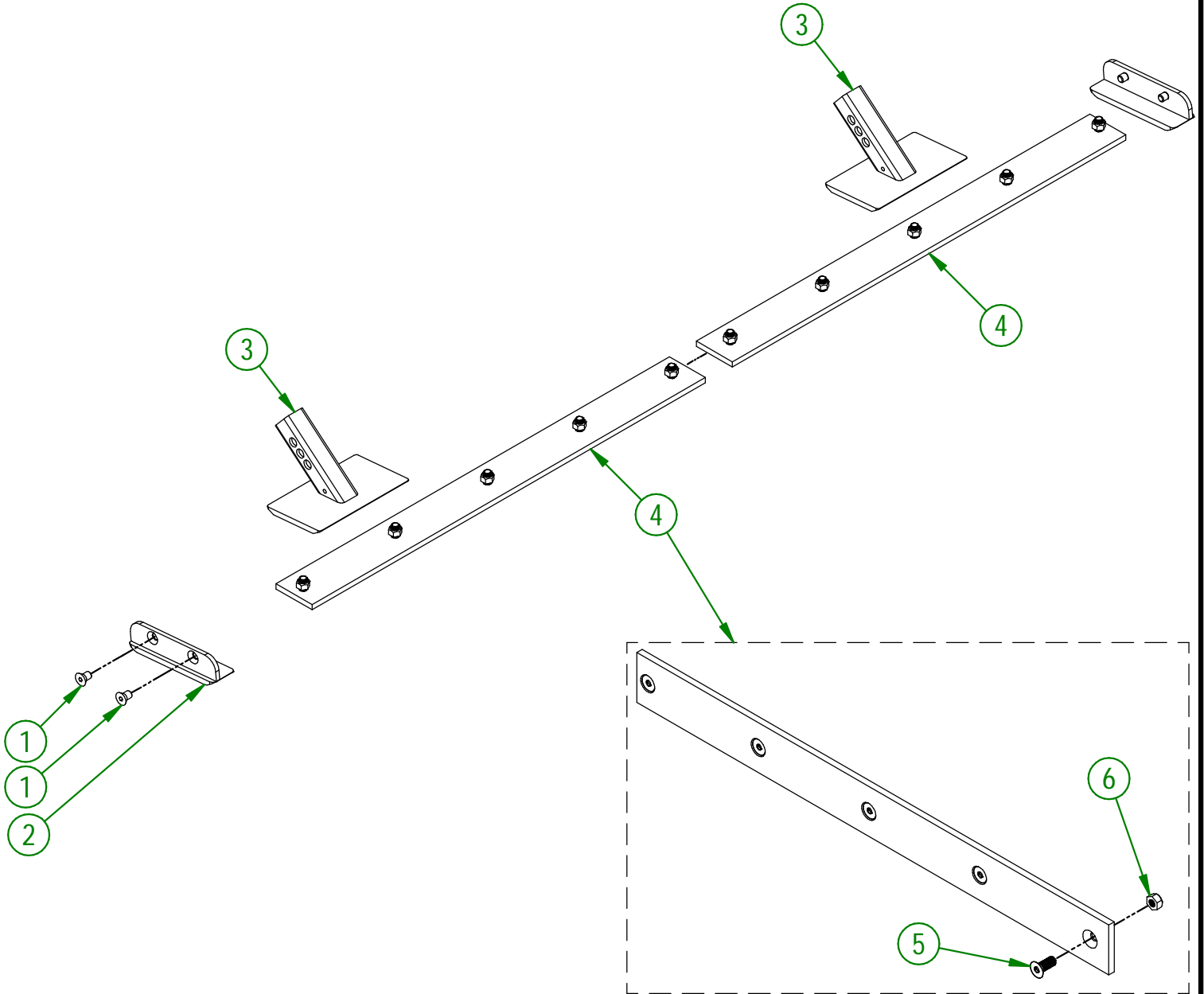

<b>AGRIMETAL</b>	
<b>SET OF KNIVES (STAINLESS STEEL)</b>	
CREATION : 19/07/16	ASSEMBLY : <b>81-57-0710</b>
REVISION : 26/09/23	AUTHOR : Dessin2

81-57-0215

#	PART #	Qty	TITLE
1	81-20-0337	1	LATERAL CUTTER BLADES (LEFT)
2	81-20-0335	1	LATERAL CUTTER BLADES (RIGHT)
3	81-10-0000	4	LATERAL CUTTER BLADES BUSHING
4	NC01-33-0248	10	HEX. BOLT .GR8 NC ZINC 1/2-13 X 1 1/4"
5	NC01-33-0514	4	HEX. BOLT GR8 ZINC 1/2-13 X 2 1/4"
6	NC02-32-0014	14	LOCK WASHER ZINC 1/2"
7	NC02-07-0020	14	HEX. NUT ZINC 1/2-13
8	81-04-0525	2	LATERAL KNIFE REINFORCE
9	NC02-22-0012	2	WASHER ZINC 1/2 BOLT = 9/16"Ø X 1 3/8" OD

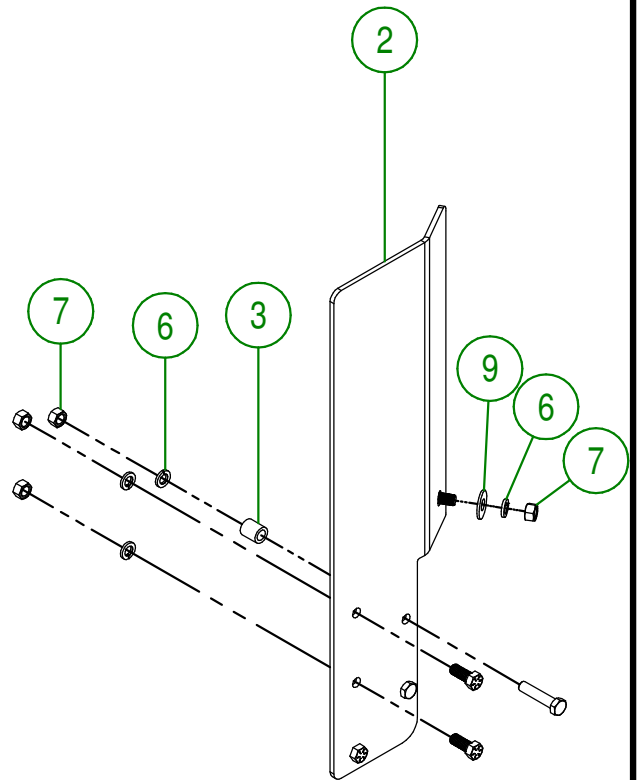
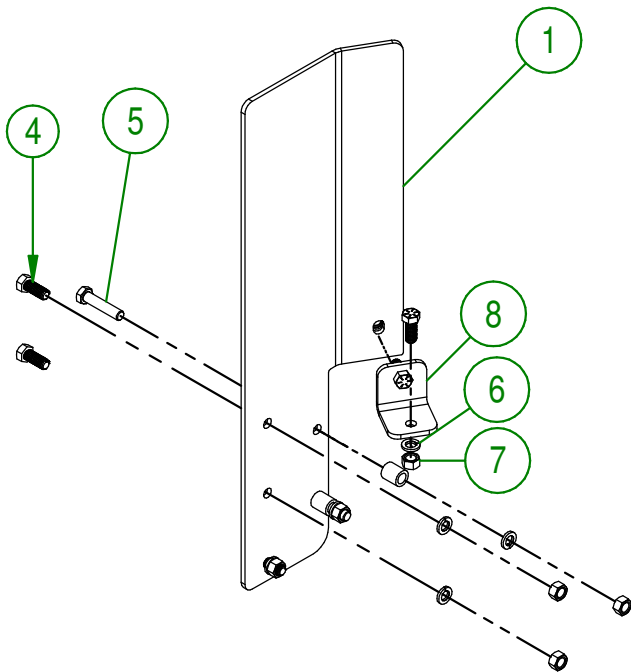

<b>AGRIMETAL</b>	
<b>LATERAL CUTTER BLADES</b>	
CREATION : 24/11/17	ASSEMBLY : <b>81-57-0215</b>
REVISION : 06/12/21	AUTHOR : J. Houle

#	PART #	Qty	TITLE
1	81-21-0030	4	CHAIN CASE SUPPORT
2	81-55-5000	1	CHAIN CASE ASSY.
3	NC01-37-0124	4	HEX. BOLT GR8 3/8-24 X 3 1/2"
4	21-01-0950	8	FLAT WASHER 10GA 1.005" DIA X 25/64"
5	NC01-94-0011	4	LOCK NUT 3/8-24
6	NC02-26-1300	10	WASHER 17/32-.531"ID X 1 1/2"OD
7	NC01-37-0263	1	HEX. BOLT GR8 NF ZINC 1/2-20 X 5" LG
8	NC01-97-0008	1	HEX. LOCK NUT NYLO. NF Z 1/2-20
9	81-57-0045	1	PTO GUARD

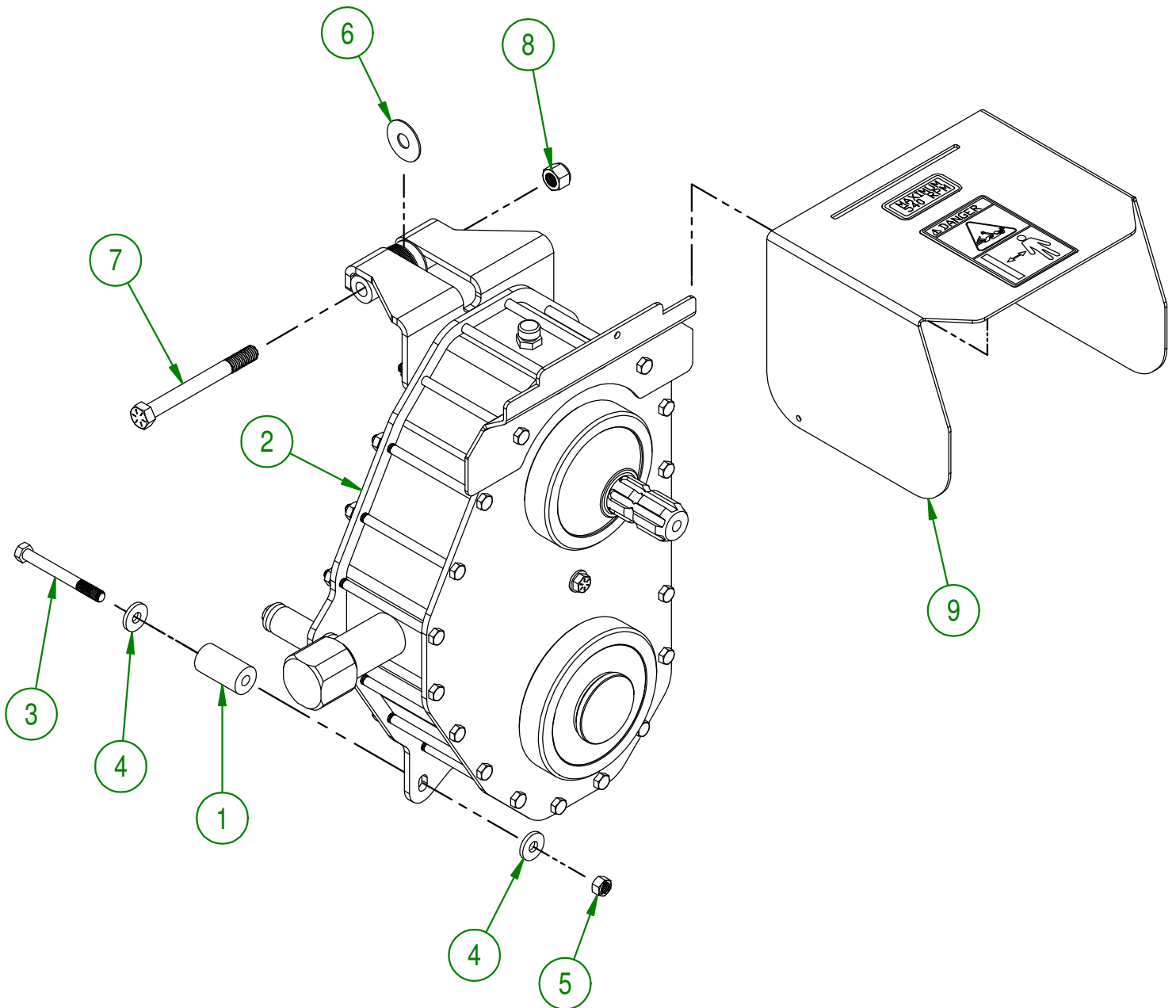

<b>AGRIMETAL</b>	
<b>CHAIN CASE GROUP.</b>	
CREATION : 09/04/18	ASSEMBLY : <b>81-57-5012</b>
REVISION : 18/11/19	AUTHOR : J.KABWE   Page 5 de 22

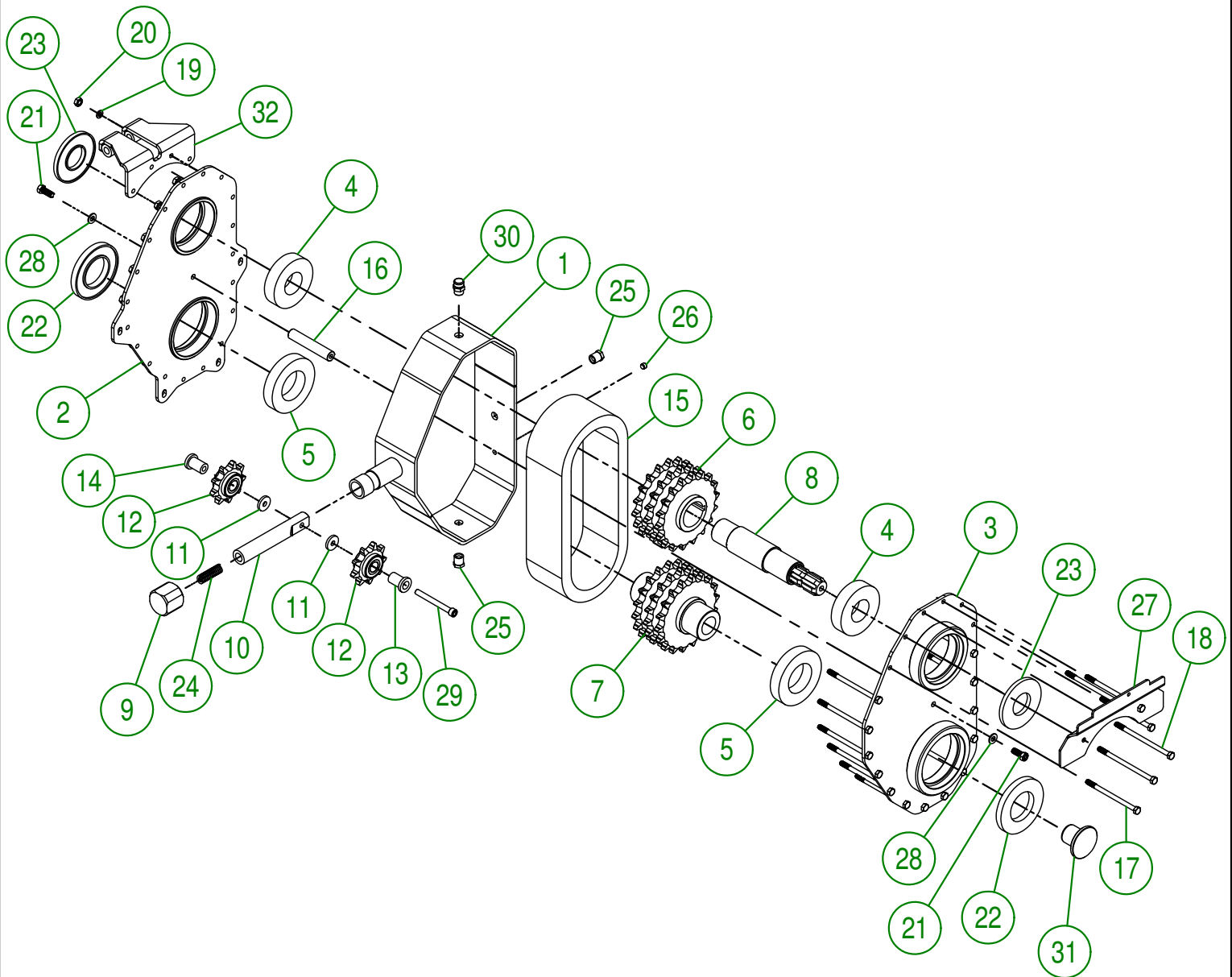

**AGRIMETAL**  
**CHAIN CASE ASSY.**

CREATION : 09/04/18  
 REVISION : 29/05/19

ASSEMBLY : **81-55-5000**

AUTHOR : J.KABWE

Page 6 de 22

#	PART #	Qty	TITLE
1	81-50-9000	1	CHAIN CASE SIDE
2	81-50-9005	1	CHAIN CASE BACK
3	81-50-9010	1	CHAIN CASE FRONT
4	NC14-75-0169	2	BEARING 6309-2RS
5	NC14-75-0168	2	BEARING 6212-2RS
6	81-50-9015	1	SPROCKET (TOP)
7	81-50-9020	1	SPROCKET (BOTTOM)
8	81-20-0040	1	SHAFT (CHAIN CASE)
9	81-21-0025	1	CHAIN CASE TIGHTENER PLUG
10	81-13-0005	1	SPRING
11	81-13-0015	2	SPACER
12	81-55-0000	2	CHAIN TENSIONER SPROCKET
13	81-13-0010	1	SPACER
14	81-13-0012	1	SPACER
15	81-37-1010	1	CHAIN #80 TRIPLE
16	81-13-0030	1	COVER BRACE
17	NC01-37-0076	15	HEX. BOLT ZINC GR8 5/16-24 X 5"
18	NC01-37-0078	4	HEX. BOLT ZINC GR8 5/16-24 X 5"
19	NC02-32-0011	19	LOCK WASHER ZINC 5/16"
20	NC02-11-0017	19	HEX. NUT 5/16-24
21	NC01-37-0114	2	BOLT GR8 3/8" X 1"
22	NC13-80-0281	2	SEALING GASKET 12mm X 60mm X 110mm
23	NC13-80-0280	2	SEALING GASKET 8mm X 45mm X 100mm
24	NC13-86-0008	1	BLUE SPRING (5/8" OD. X 4")
25	NC13-45-0221	2	HEXAGONAL PLUG
26	NC02-44-0202	1	PRESSURE SCREW 6PANS NPTF 1/8-27
27	81-01-0924	1	PTO GUARD SUPPORT (CHAIN CASE)
28	49-22-1810	2	WASHER
29	NC02-51-0128	1	SOCKET HAED SCREW 3/8-24 X 3 1/2"
30	NC14-10-0160	1	PLUG
31	81-42-0000	1	HUB PLUG
32	81-50-9025	1	CHAINCASE BRACE

**AGRIMETAL**  
CHAIN CASE ASSY.

CREATION : 09/04/18  
REVISION : 29/05/19

ASSEMBLY : **81-55-5000**

AUTHOR : J.KABWE

Page 7 de 22



#	PART #	Qty	TITLE
1	81-50-0090	1	STAND
2	NC01-63-0026	1	COTTER PIN ZC 5/32" X 3"
3	48-20-0065	2	3 POINT PIN
4	NC01-69-1100	3	LINCH PIN 3/8"
5	48-20-0060	1	3 POINT PIN
6	NC01-69-1306	1	LOCKING PIN 3/8" X 2 1/2" LG
7	NC13-15-0300	1	SNOW GUARD
8	NC01-78-0016	6	ALUMINIUM BLIND POP RIVET STEEL MANDREL 0.187 X 0.690
9	80-01-1075	1	SNOW GUARD BRACE
10	NC01-33-0481	4	HEX. BOLT GR8 ZINC 3/4-10 X 5 1/2"
11	22-04-6805	4	FLAT WASHER BEARING BASE
12	NC01-93-0017	4	HEX. LOCKNUT STEEL NC Z 3/4-10
13	81-57-6505	1	FRAME
14	81-50-5040	2	ATTACHMENT HAND
15	NC13-15-0321	1	RUBBER
16	NC01-17-0060	7	HEX. BOLT GR2 ZINC 5/16-18 X 1"
17	NC01-93-0010	7	LOCK NUT ZINC 5/16-18
18	81-57-0250	1	RUBBER REINFORCEMENT
19	NC01-17-0396	6	HEX. BOLT GR2 ZINC 5/8-11 X 2"
20	NC02-07-0022	6	HEX. NUT ZINC 5/8-11
21	NC01-25-0481	2	HEX. BOLT GR5 NC 3/4-10 X 5"
22	NC01-96-0017	2	HEX. LOCK NUT NYLO. NC 3/4-10

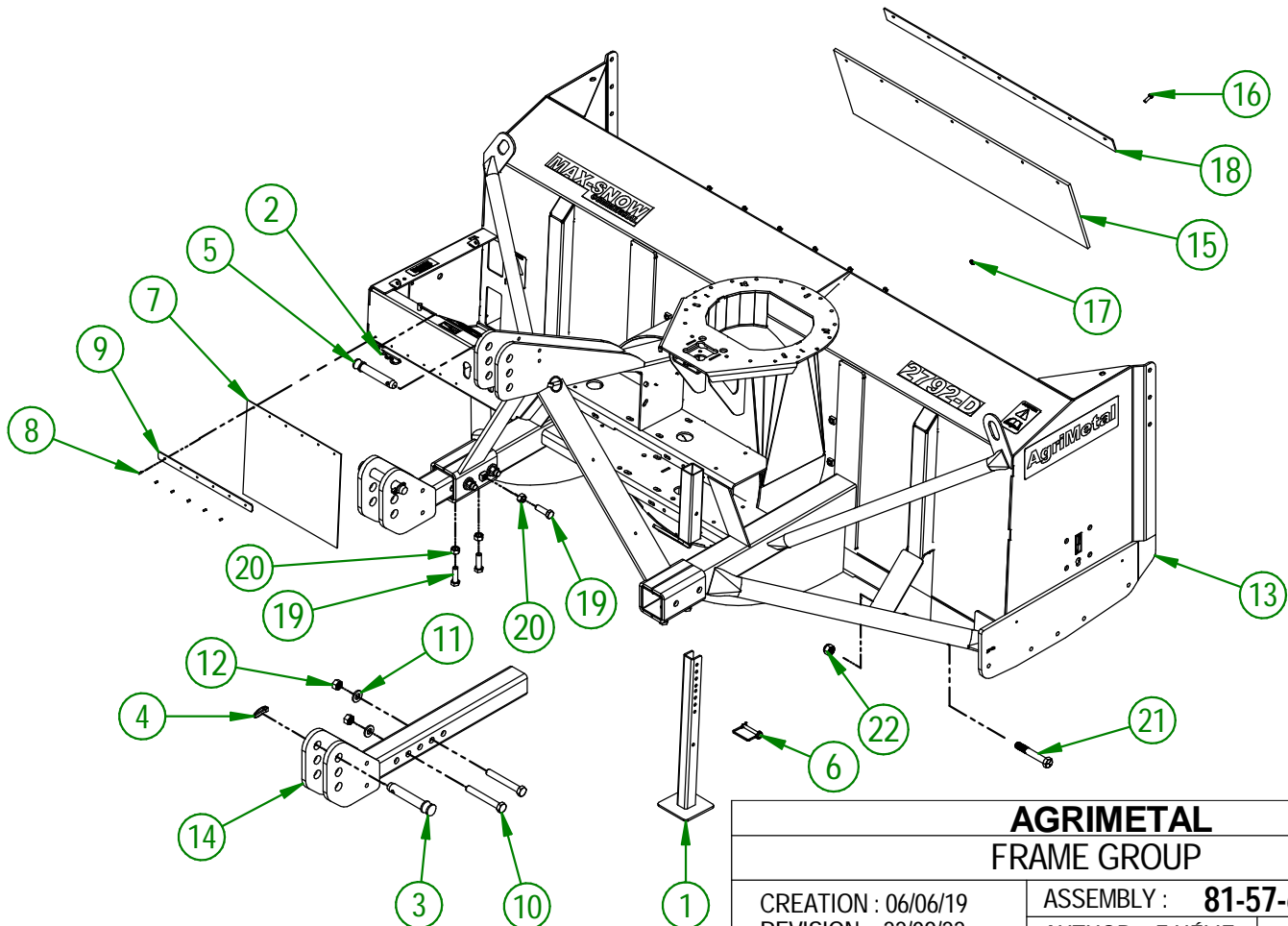

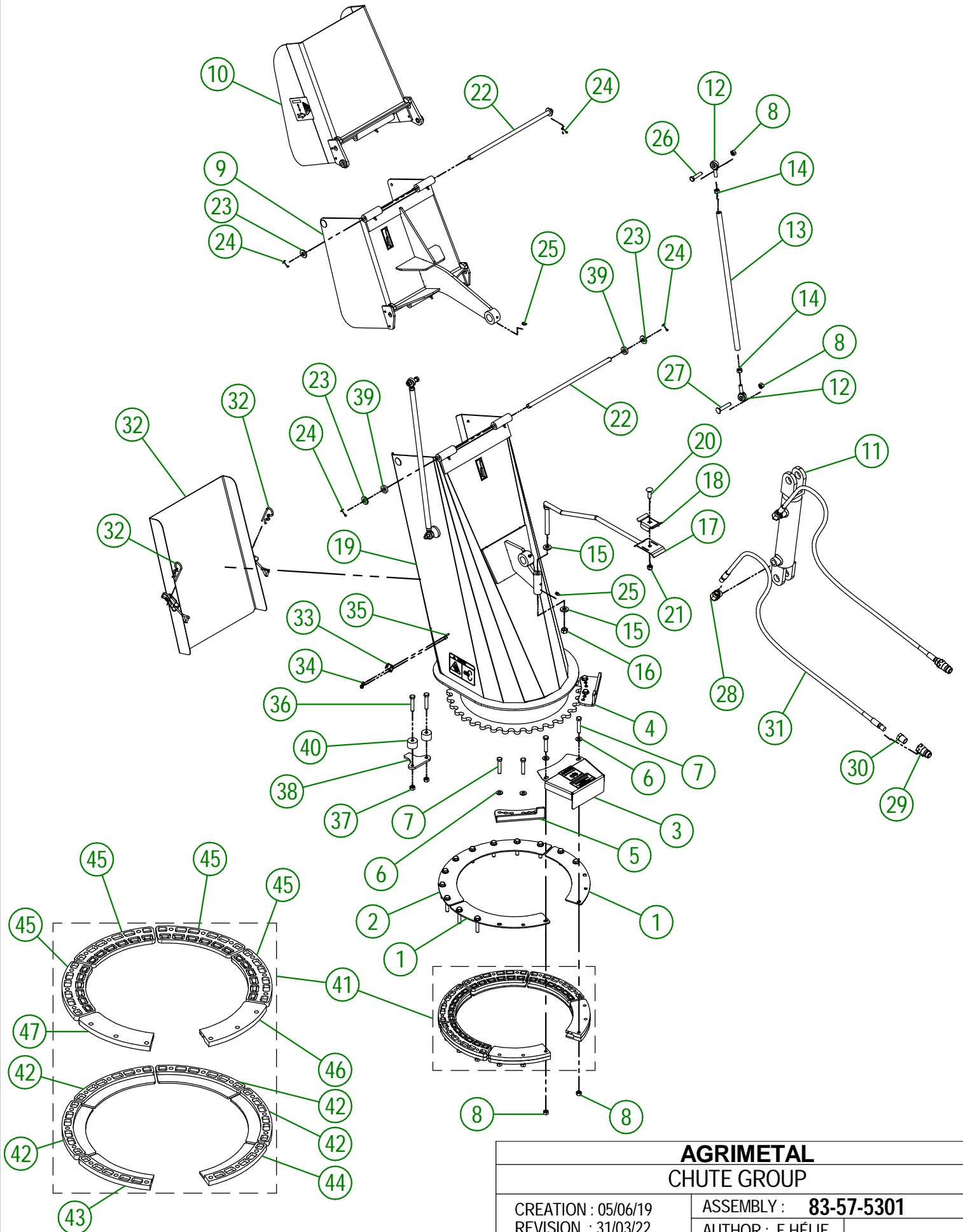

**AGRIMETAL**  
**CHUTE GROUP**

CREATION : 05/06/19  
REVISION : 31/03/22

ASSEMBLY : **83-57-5301**  
AUTHOR : F.HÉLIE

## 83-57-5301

#	PART #	Qty	TITLE
1	48-01-1165	2	BRACE
2	48-01-1167	1	BRACE
3	80-57-0550	1	SPROCKET GUARD GROUP "STICKER INCLUDED"
4	81-04-0177	1	ADJUSTABLE STOPPER
5	81-04-0175	1	ADJUSTABLE STOPPER
6	01-01-2485	18	FLAT WASHER 14 GA X 13/16"OD X 25/64" ID
7	NC01-17-0118	18	HEX. BOLT GR2 ZINC 3/8-16 X 2"
8	NC01-93-0011	22	LOCK NUT 3/8-16
9	83-57-5310	1	CHUTE (MIDDLE SECTION)
10	83-57-5315	1	CHUTE (TOP SECTION)
11	NC13-45-0209	1	HYDRAULIC CYLINDER 6"
12	NC01-67-0304	4	ROD END 3/8-24
13	48-13-0600	2	CHUTE ROD (DOUBLE)
14	NC02-10-0018	4	NUT 3/8-24
15	01-01-0925	2	WASHER
16	NC01-96-0014	1	NYLON-INSERT LOCKNUT ZINC 1/2-13
17	48-50-1030	1	HYDRAULIC HOSE SUPPORT
18	48-01-7530	1	HYDRAULIC HOSE SUPPORT
19	83-57-5305	1	CHUTE (BOTTOM SECTION)
20	NC01-04-0110	1	CARR. BOLT GR2 ZINC 3/8-16 X 1 1/4"
21	NC01-96-0011	1	NYLON NUT 3/8-16
22	83-20-0050	2	PIVOT
23	NC02-25-0011	4	WASHER SAE ZINC 17/32 ID
24	NC01-69-0139	4	COTTER PIN ZINC 1/8" X 3/4"
25	NC01-69-0785	9	STRAIGHT GREASE FITTING 1/4-28
26	NC01-25-0116	2	HEX. BOLT GR5 ZINC 3/8-16 X 1 1/2"
27	NC01-07-0113	2	CARR. BOLT GR5 ZINC 3/8-16 X 2" LG
28	NC13-45-0038	2	ELBOW 90 3/8 FEM. NPT X 3/8 MALE NPT
29	NC13-45-0369	2	QUICK COUPLER 1/2-14 NPTF
30	NC13-45-0153	2	HEX. REDUCER 1/4 NPT X 1/2 NPT
31	NC17-02-0347	2	HYDRAULIC HOSE (111" LG)
32	83-57-5350	1	CHUTE DOOR
33	NC01-63-0052	2	ADJUSTABLE LATCH (STRIKE)
34	NC01-96-0006	4	NYLON NUT ZINC 3/16
35	NC02-40-0080	4	MACHINE SCREWS SQUARE SOCKET #10-24 X 1/2" LG
36	NC01-37-0118	2	HEX. BOLT GR8 ZINC 3/8-24 X 2"
37	NC01-94-0011	2	LOCK NUT 3/8-24
38	84-04-0170	1	STOPPER
39	NC13-15-0334	2	PIVOT WASHER
40	81-21-0040	2	ADJUSTABLE STOPPER SPACER
41	81-57-0550	1	CHUTE GUIDE GROUP

## 81-57-0550

#	PART #	Qty	TITLE
42	NC17-46-0025	4	CHUTE GUIDE (UNDER)
43	48-42-0305	1	CHUTE GUIDE (UNDER)
44	48-42-0310	1	CHUTE GUIDE (UNDER)
45	NC17-46-0026	4	CHUTE GUIDE (TOP)
46	48-42-0320	1	CHUTE GUIDE (TOP)
47	48-42-0315	1	CHUTE GUIDE (TOP)

#	PART #	Qty	TITLE
1	NC14-45-0156	1	HYDRAULIC MOTOR
2	NC02-32-0012	6	LOCK WASHER ZINC 3/8"
3	NC01-17-0112	4	HEX. BOLT GR2 ZINC 3/8-16 X 3/4"
4	48-50-1025	1	HYDRAULIC ENGINE SPROCKET
5	01-33-0010	1	WASHER
6	NC02-32-0011	1	LOCK WASHER ZINC 5/16"
7	NC01-45-0184	1	HEX. BOLT GR8.8 ZINC 8MM X 20MM
8	NC13-45-0367	2	45°-7/8-14 MALE O RING X 1/2 FEM.TOUR.NPT PT
9	NC13-45-0369	2	QUICK COUPLER 1/2-14 NPTF
10	80-45-0000	2	HEX. REDUCER 1/4 NPT X 1/2 NPT
11	NC17-02-0406	2	HYDRAULIC HOSE (87" LG)
12	80-13-0100	2	HYDRAULIC RESTRICTOR
13	NC13-45-0378	2	HYDRAULIC RESTRICTOR BUSHING
14	NC17-46-0031	1	HYDRAULIC MOTOR BUSHING
15	81-01-7600	1	HYDRAULIC HOSE SUPPORT
16	80-01-0020	1	HYDRAULIC HOSE SUPPORT
17	01-01-2485	2	FLAT WASHER 14 GA X 13/16"OD X 25/64" ID
18	NC01-17-0115	2	HEX. BOLT GR2 ZINC 3/8-16 X 1 1/4"
19	NC02-07-0018	2	HEX. NUT ZINC 3/8-16
20	NC01-96-0011	1	NYLON NUT 3/8-16
21	NC01-04-0111	1	CARR. BOLT GR2 ZINC 3/8-16 X 1 1/2"
22	NC02-44-0103	2	SET SCREW 5/16-18 X 3/8"

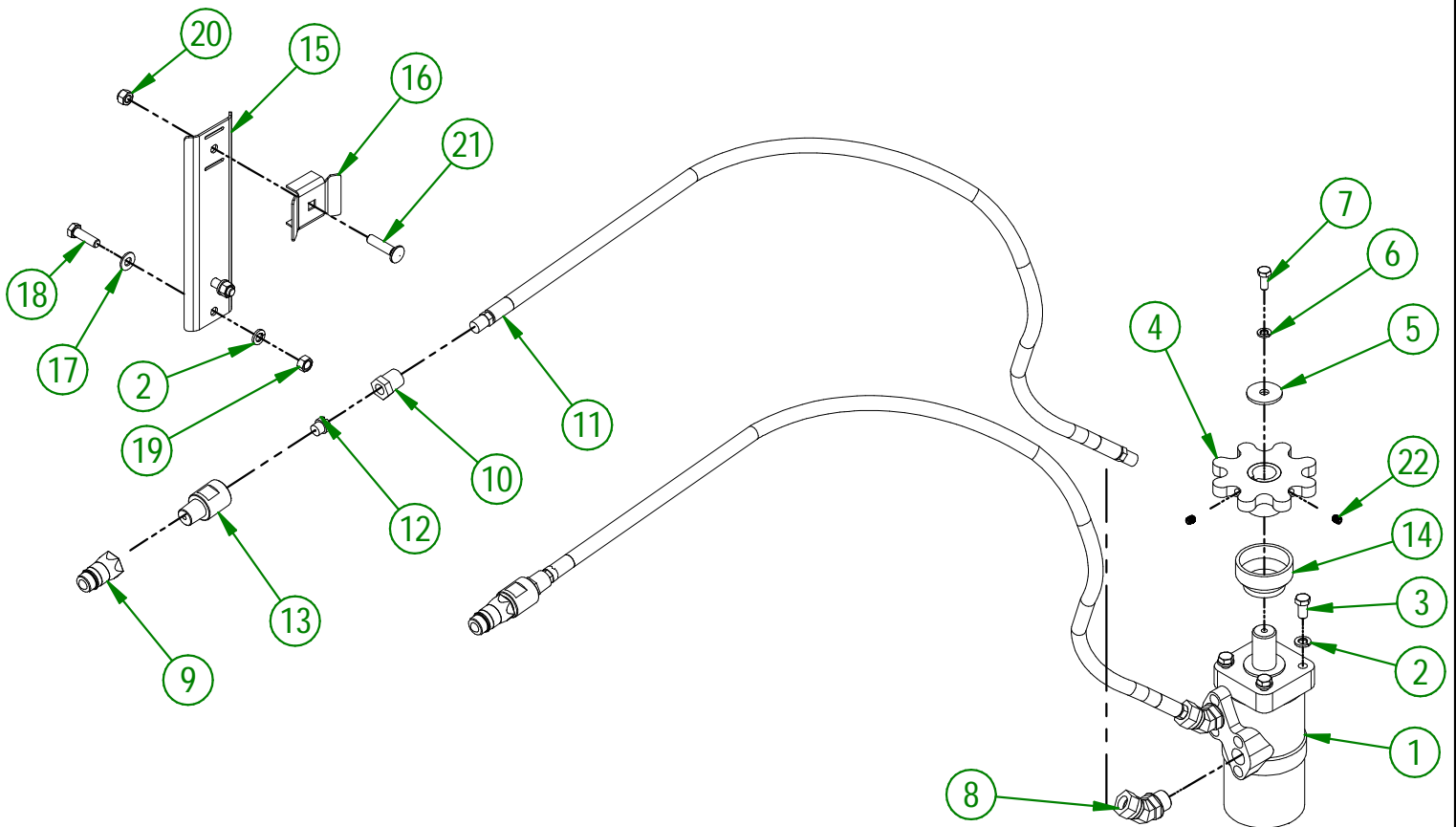

**AGRIMETAL**  
**HYDRAULIC MOTOR GROUP**

CREATION : 05/12/17  
REVISION : 28/03/22

ASSEMBLY : **81-57-5045**  
AUTHOR : F.HÉLIE

#	PART #	Qty	TITLE
1	80-55-0010	1	GEARBOX
2	NC02-25-0011	14	WASHER SAE ZINC 17/32 ID
3	NC02-32-0014	12	LOCK WASHER ZINC 1/2"
4	NC01-33-0253	4	HEX. BOLT GR8 ZINC 1/2-13 X 2 1/2"
5	NC01-33-0248	4	HEX. BOLT .GR8 NC ZINC 1/2-13 X 1 1/4"
6	81-21-0005	4	TRANSMISSION BUSHING
7	80-41-0135	1	PTO GUARD STEEL CABLE
8	NC01-64-0005	2	OVAL SLEEVE (ALUMINUM)
9	80-41-0900	1	IMPELLER KEY
10	NC13-25-0019	1	BLACK TIE RAP
11	NC13-50-0110	1	IMPORTANT/NOTICE PTO POSTER
12	81-57-0040	1	PTO GUARD
13	81-34-0035	1	PTO SHAFT T80
14	NC01-63-0027	1	HAIRPIN COTTER
15	80-04-0485	1	GEARBOX BRACE
16	80-04-0480	1	GEARBOX BRACE
17	81-01-0921	1	PTO GUARD SUPPORT
18	NC01-33-0249	4	CAP SCREW GR8 NC ZINC 1/2-13 X 1 1/2" LG
19	NC02-07-0020	4	HEX. NUT ZINC 1/2-13

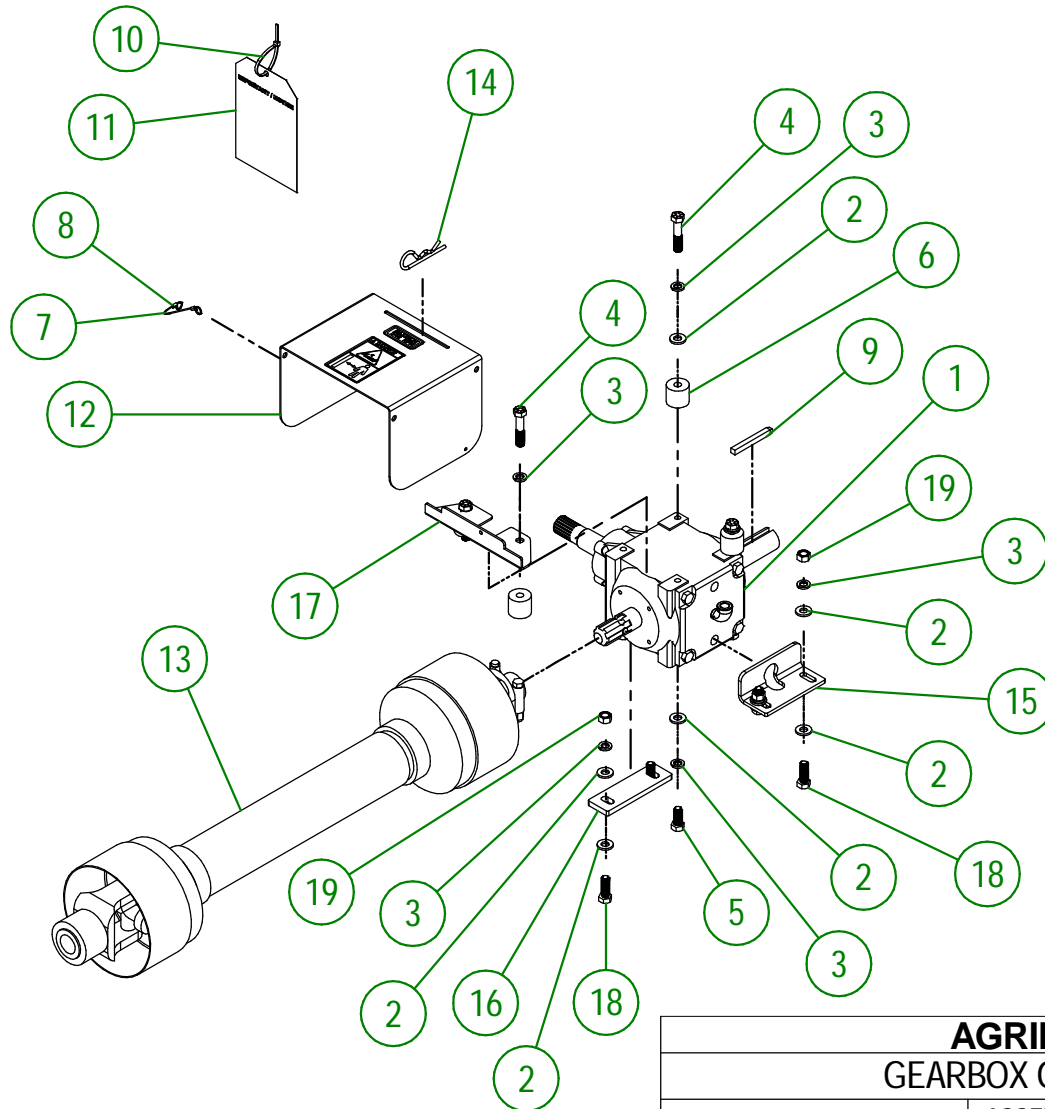

<b>AGRIMETAL</b>	
<b>GEARBOX GROUPING</b>	
CREATION : 19/07/16	ASSEMBLY : <b>81-57-0430</b>
REVISION : 02/03/22	AUTHOR : Dessin2

81-57-5100

#	PART #	Qty	TITLE
1	81-50-7000	1	IMPELLER MS 27-D
2	NC01-37-0255	2	HEX BOLT GR8 1/2" X 3" LG.
3	NC01-94-0013	2	NYLON NUT ZINC 1/2-20"
4	NC01-25-0395	1	HEX. BOLT GR5 ZINC 5/8-11 X 1 3/4" LG
5	NC02-32-0016	1	LOCK WASHER ZINC 5/8"
6	80-04-0185	1	WASHER
7	NC01-69-0791	1	GREASE FITTING 1/8 NPT STRAIGHT
8	81-01-0055	1	WASHER
9	NC01-21-0463	2	HEX. BOLT GR2 ZINC 3/4-16 X 1" LG

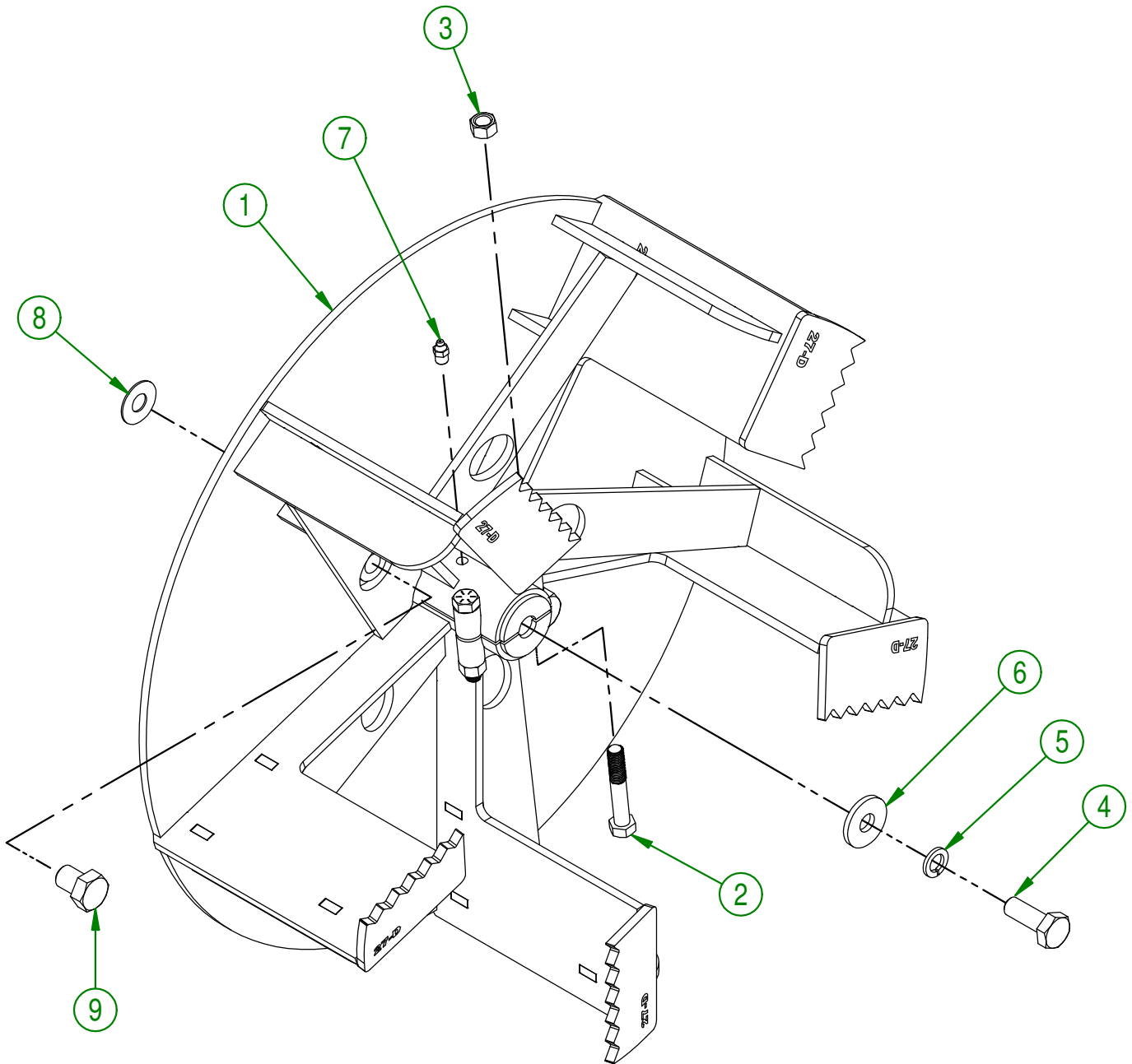

<b>AGRIMETAL</b>	
<b>IMPELLER GROUP (MS 27-D)</b>	
CREATION : 10/06/19	ASSEMBLY : <b>81-57-5100</b>
REVISION : 06/11/19	AUTHOR : F.HÉLIE Page 13 de 22

81-57-6025

#	PART #	Qty	TITLE
1	81-50-6020	1	LEFT SNOW GUARD
2	81-50-6025	1	RIGHT SNOW GUARD
3	NC02-32-0014	6	LOCK WASHER ZINC 1/2"
4	NC01-25-0249	6	HEX. BOLT GR5 ZINC 1/2-13 X 1 1/2" LG

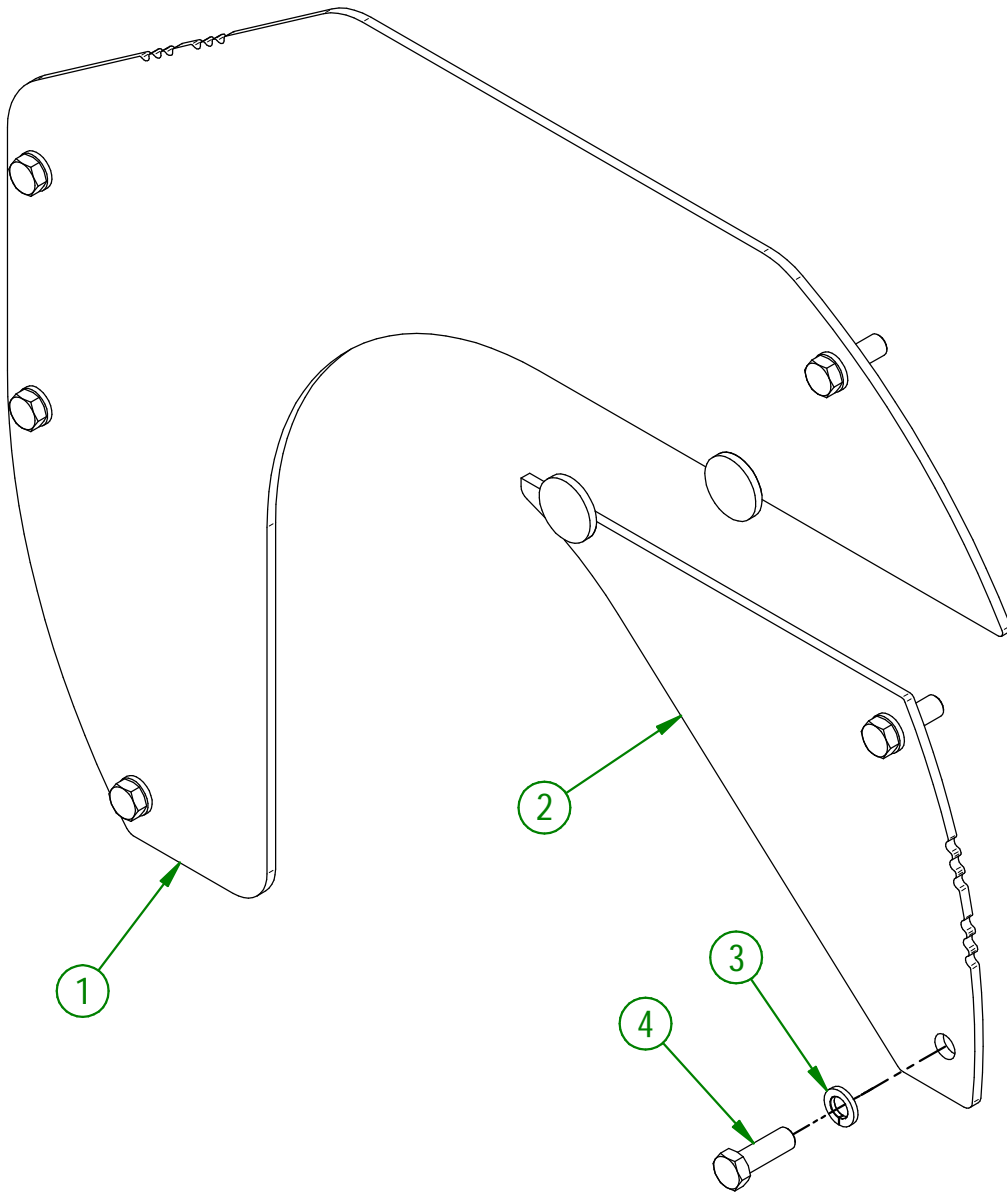

<b>AGRIMETAL</b>	
<b>SNOW GUARD GROUP</b>	
CREATION : 05/06/19	ASSEMBLY : <b>81-57-6025</b>
REVISION : 28/09/22	AUTHOR : F.HÉLIE



#	PART #	Qty	TITLE
1	NC14-75-0161	2	FLANGE BEARING UCF 208-24 1 1/2" ID
2	81-50-1530	1	SPIRAL
3	NC02-32-0016	8	LOCK WASHER ZINC 5/8"
4	NC02-07-0022	8	HEX. NUT ZINC 5/8-11
5	NC02-25-0013	8	WASHER ZINC SAE ZINC 21/32 ID
6	NC01-17-0396	4	HEX. BOLT GR2 ZINC 5/8-11 X 2"
7	NC01-17-0395	4	HEX. BOLT GR2 ZINC 5/8-11 X 1 3/4"
8	NC14-55-0275	1	SPROCKET 80A34 X 1 1/2"
9	NC01-29-0249	4	HEX. BOLT GR2 NC ZINC 1/2-20 X 1 1/2"
10	NC01-94-0013	4	HEX. LOCK NUT NF ZINC 1/2-20
11	81-51-0086	1	SHAFT OF THE SPIRAL
12	81-51-0091	1	SHAFT OF THE SPIRAL (SPROCKET)

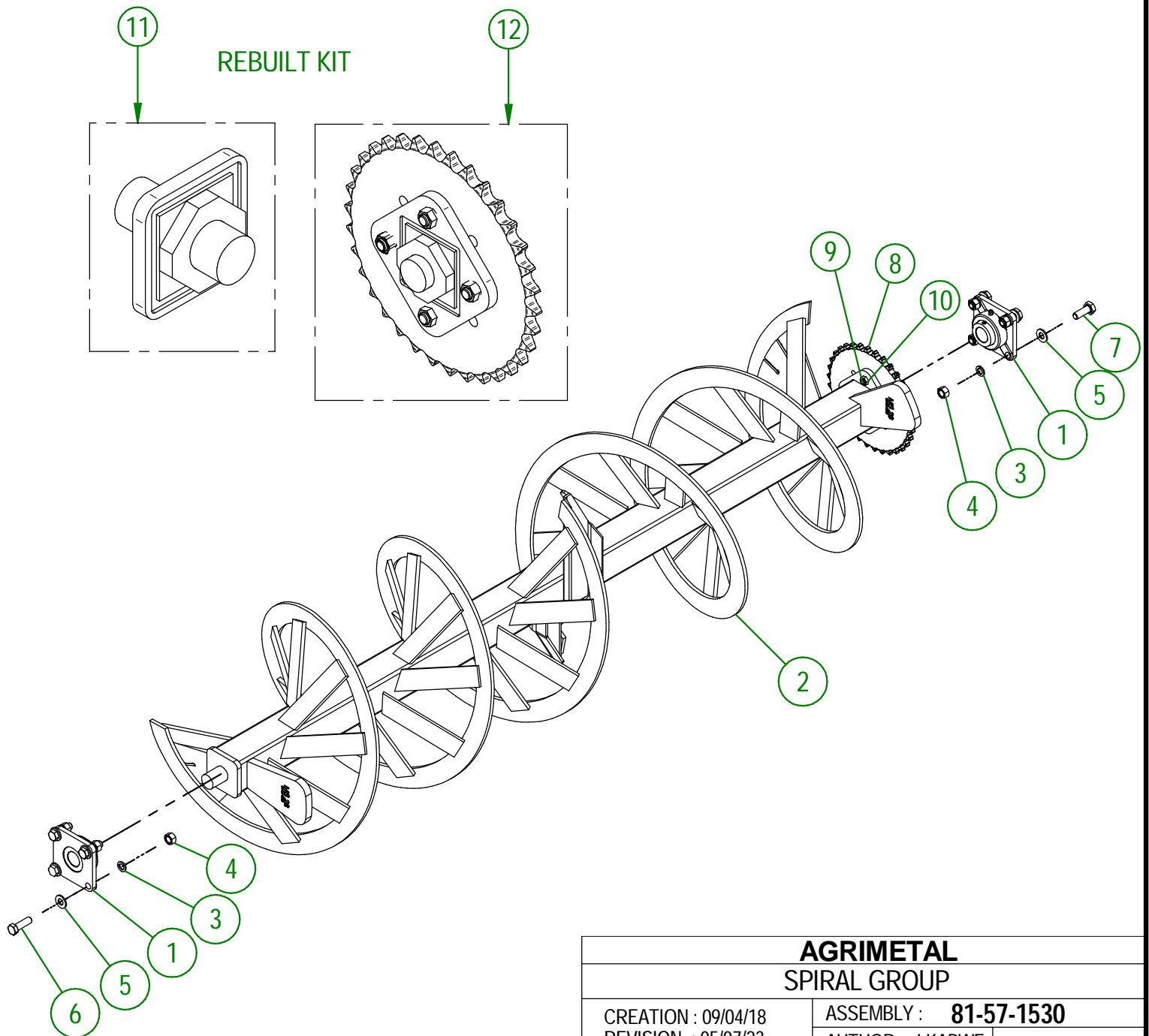

<b>AGRIMETAL</b>	
<b>SPIRAL GROUP</b>	
CREATION : 09/04/18	ASSEMBLY : <b>81-57-1530</b>
REVISION : 05/07/23	AUTHOR : J.KABWE





## 81-57-6520

#	PART #	Qty	TITLE
1	81-50-6510	1	SPIRAL DRIVE TRAIN
2	81-04-0010	1	BEARING SUPPORT
3	81-21-0010	1	SPIRAL DRIVE TRAIN BUSHING
4	NC14-75-0025	1	FLANGE BEARING 4 HOLES UCF 208-24 X 1 1/2"
5	NC02-25-0011	1	WASHER SAE ZINC 17/32 ID
6	NC13-86-0054	1	BLUE SPRING 1/2" ID X 1" OD X 6" LG
7	NC01-96-0014	1	NYLON-INSERT LOCKNUT ZINC 1/2-13
8	80-42-0110	1	THREADED ROD CAP
9	NC01-69-0785	2	STRAIGHT GREASE FITTING 1/4-28
10	01-01-2485	8	FLAT WASHER 14 GA X 13/16"OD X 25/64" ID
11	NC01-17-0114	8	HEX. BOLT GR2 ZINC 3/8-16 X 1"
12	NC02-32-0012	8	LOCK WASHER ZINC 3/8"
13	NC02-07-0018	8	HEX. NUT ZINC 3/8-16
14	NC02-32-0016	4	LOCK WASHER ZINC 5/8"
15	NC02-07-0022	4	HEX. NUT ZINC 5/8-11
16	NC01-17-0395	4	HEX. BOLT GR2 ZINC 5/8-11 X 1 3/4"
17	NC01-93-0011	1	LOCK NUT 3/8-16
18	NC01-25-0116	1	HEX. BOLT GR5 ZINC 3/8-16 X 1 1/2"
19	81-55-0400	1	CHAIN TENSIONER GROUP
20	81-37-1020	1	#80 HD CHAIN
21	81-50-5035	1	CHAIN TENSIONER THREADED ROD
22	NC01-69-0787	1	GREASE FITTING STRAIGHT 1/4-28 X 90
23	81-04-0135	1	WASHER 2.015" DIA. X 49/64"
24	NC02-32-0017	1	LOCK WASHER ZINC 3/4"
25	NC01-25-0467	1	HEX. BOLT GR2 ZINC 3/4-10 X 2 " LG.
26	NC14-55-0328	1	SPROCKET
27	81-57-0160	1	ADJUSTEMENT INDICATOR

## 81-55-0400

#	PART #	Qty	TITLE
28	88-13-0005	1	CHAIN TENSIONER BUSHING
29	81-50-5005	1	CHAIN TENSIONER
30	81-21-0020	2	CHAIN TENSIONER BUSHING
31	81-55-0005	2	CHAIN TENSIONER SPROCKET
32	NC01-17-0398	2	HEX. BOLT GR2 NC ZINC 5/8-11 X 2 1/2"
33	NC02-22-0013	2	WASHER ZINC 5/8 ID X 1 1/2 OD
34	NC02-32-0016	2	LOCK WASHER ZINC 5/8"
35	NC02-10-0022	2	HEX. NUT ZINC 5/8-18
36	NC01-69-0786	1	GREASE FITTING 1/4-28 X 45

**AGRIMETAL****SPIRAL DRIVE TRAIN GROUP**

CREATION : 06/06/19

REVISION : 28/03/23

ASSEMBLY : **81-57-6520**

AUTHOR : F.HÉLIE

81-57-6030

#	PART #	Qty	TITLE
1	81-50-6030	1	CHAIN GUARD
2	NC01-04-0107	6	CARR. BOLT GR2 ZINC 3/8-16 X 3/4"
3	NC02-14-0019	6	FLANGE NUT HEX. NC 3/8-16 GR. B

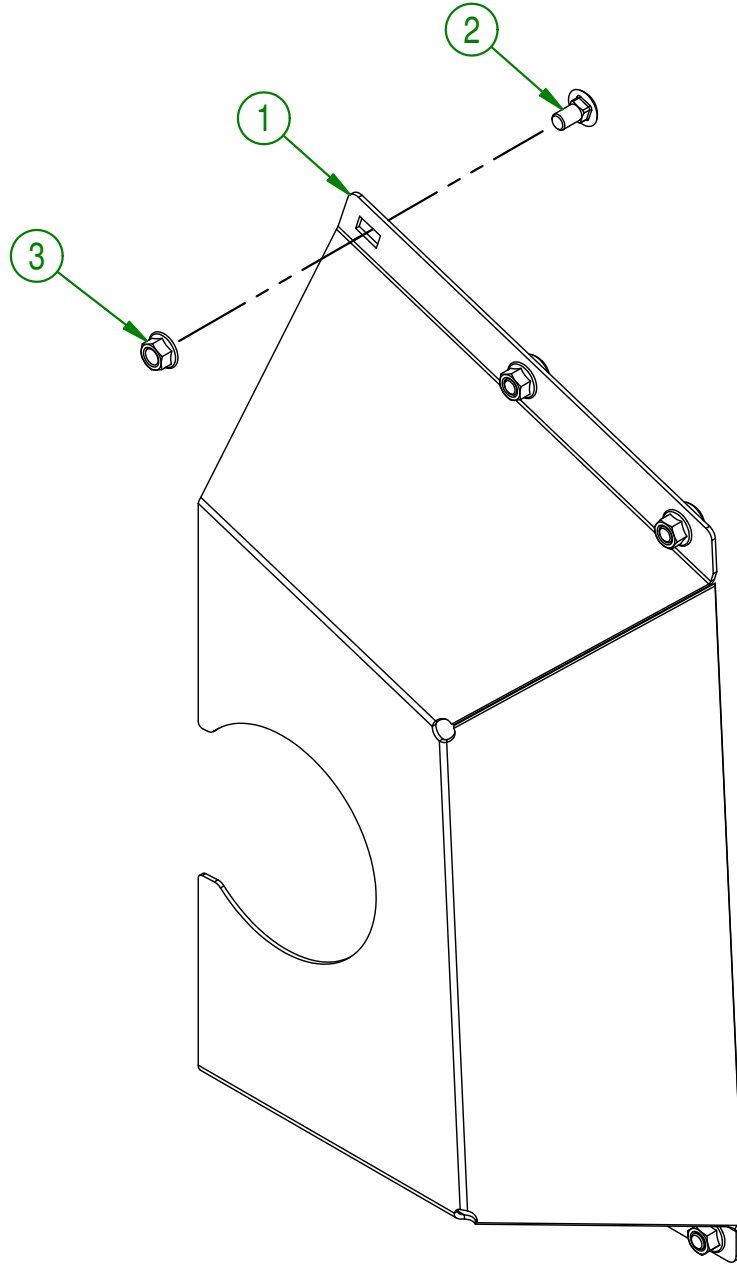

<b>AGRIMETAL</b>	
<b>SPIRAL CHAIN GUARD GROUP</b>	
CREATION : 05/06/19	ASSEMBLY : <b>81-57-6030</b>
REVISION : 05/06/19	AUTHOR : F.HÉLIE Page 18 de 22

81-57-6010

#	PART #	Qty	TITLE
1	81-57-6015	1	CHAIN GUARD
2	01-01-2485	4	FLAT WASHER 14 GA X 13/16"OD X 25/64" ID
3	NC01-17-0114	2	HEX. BOLT GR2 ZINC 3/8-16 X 1"
4	NC01-96-0011	2	NYLON NUT 3/8-16

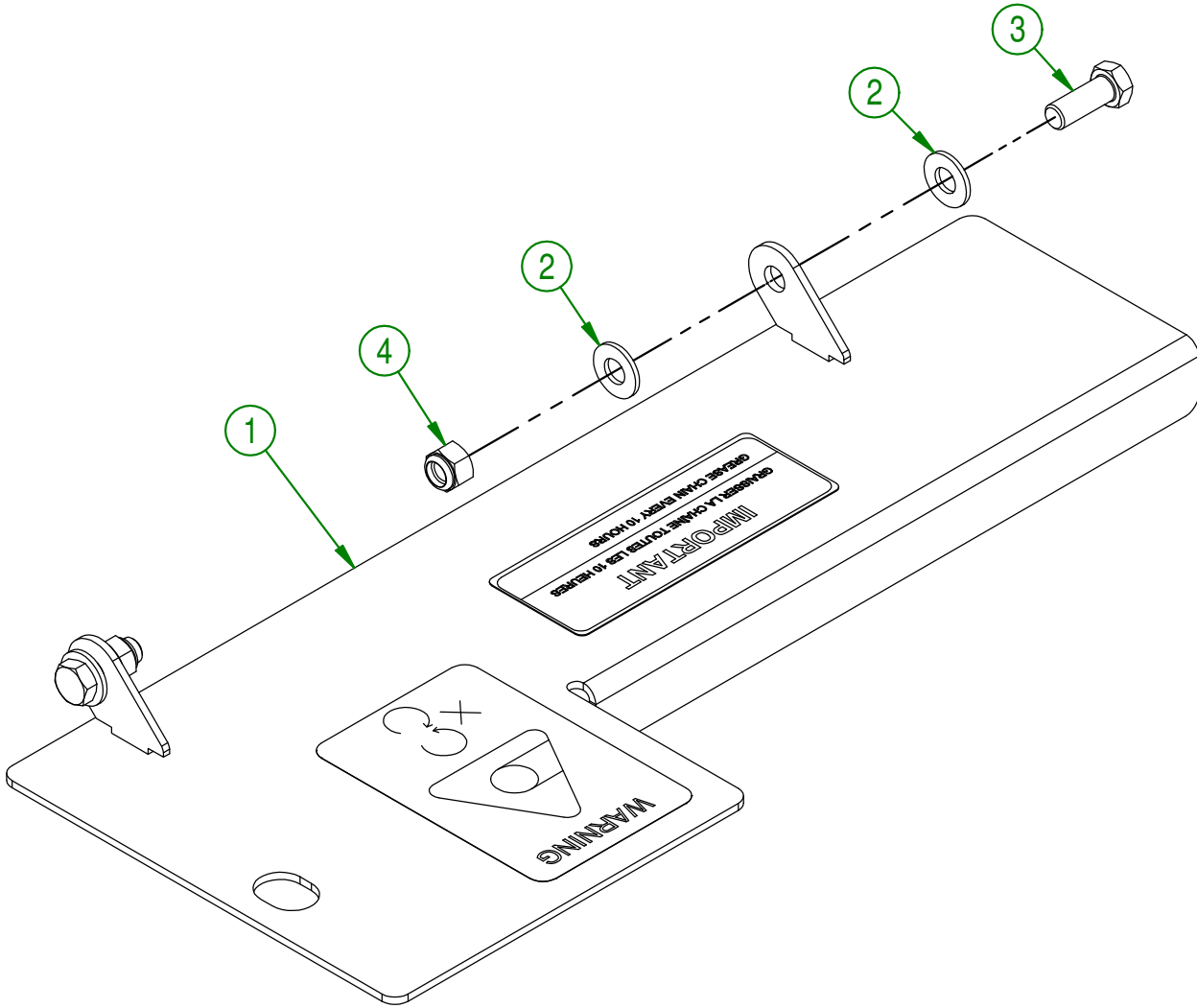

<b>AGRIMETAL</b>	
<b>CHAIN GUARD GROUP</b>	
CREATION : 05/06/19	ASSEMBLY : <b>81-57-6010</b>
REVISION : 18/11/19	AUTHOR : F.HÉLIE Page 19 de 22

#	PART #	Qty	TITLE
1	NCI3-30-0237	1	PLASTIC TUBE FOR OPERATOR'S MANUAL
2	NC02-25-0007	2	WASHER ZINC 0.281 = 9/32
3	NC01-17-0007	2	HEX. BOLT GR2 ZINC 1/4-20 X 1 1/4"
4	NC01-96-0009	2	NYLON-INSERT LOCKNUT ZINC 1/4-20
5	81-57-0030	1	SET OF 6 SHEAR BOLT WITH NUT
6	81-98-0521	1	ENGLISH OPERATOR'S MANUAL (MS28 & 30)

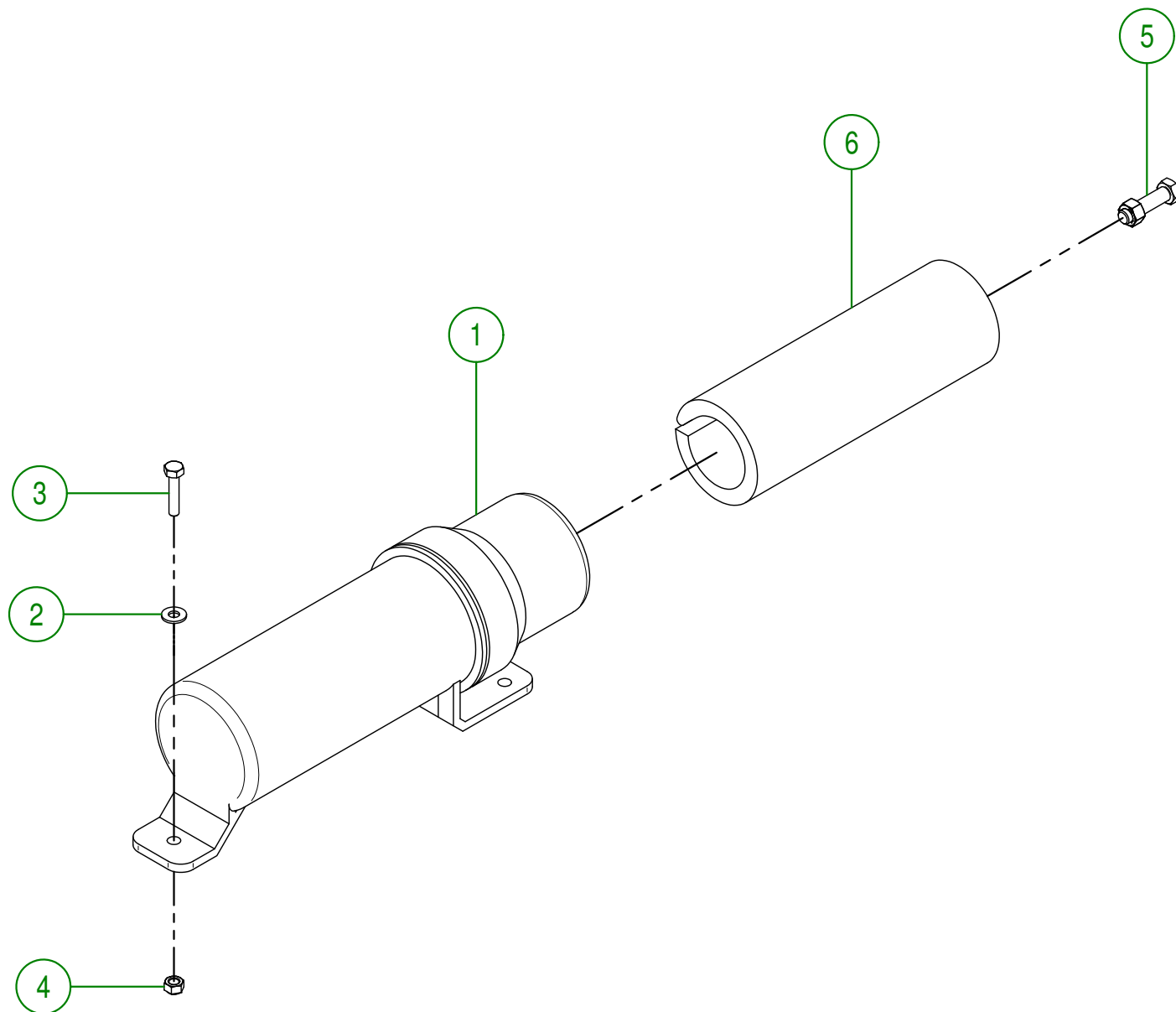

<b>AGRIMETAL</b>	
OPERATOR'S MANUAL TUBE GROUP	
CREATION : 19/07/16	ASSEMBLY : <b>81-57-0400</b>
REVISION : 21/05/19	AUTHOR : J. HOULE   Page 20 de 22

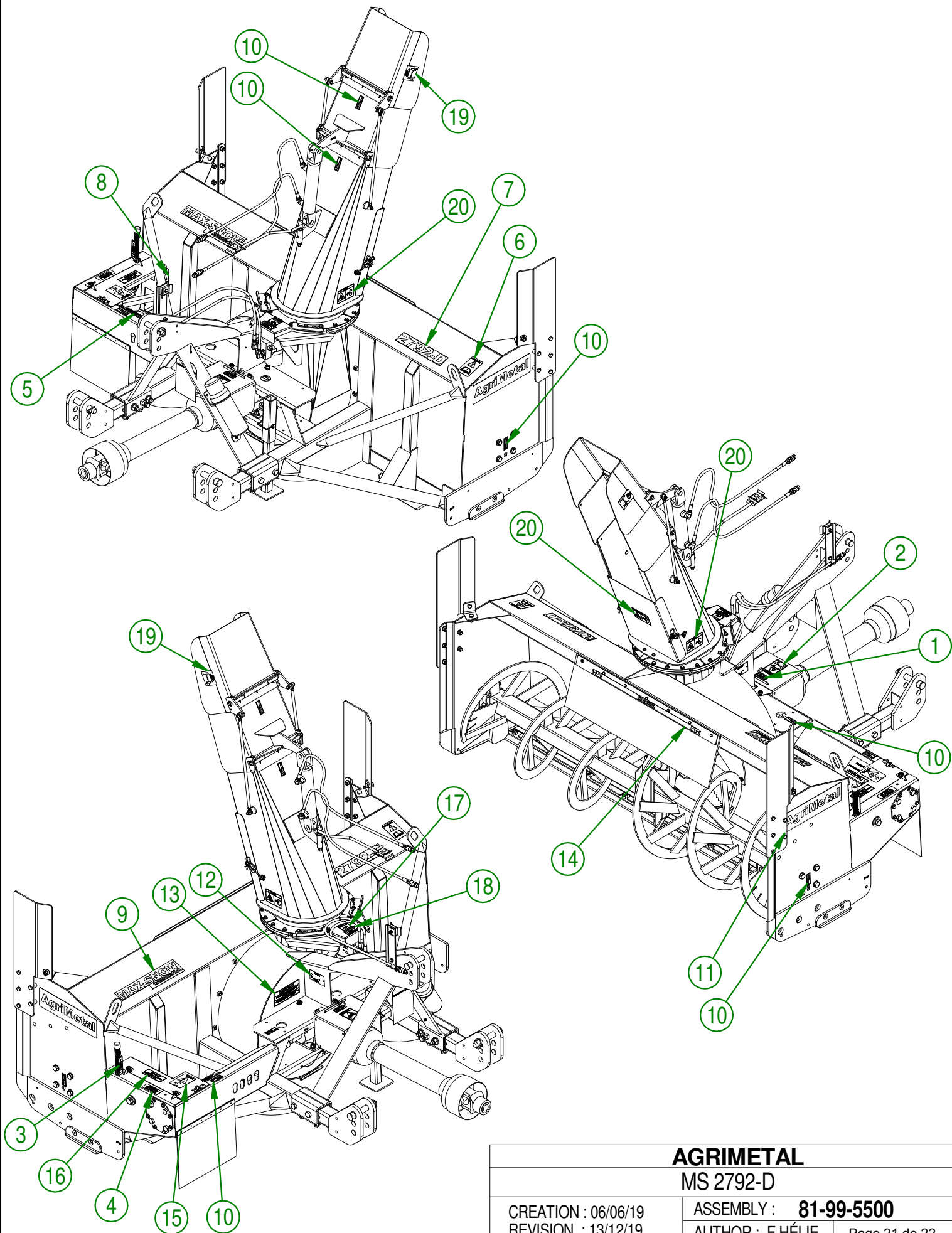

**AGRIMETAL**  
**MS 2792-D**

CREATION : 06/06/19  
 REVISION : 13/12/19

ASSEMBLY : **81-99-5500**

AUTHOR : F.HÉLIE Page 21 de 22

#	PART #	QTY	TITLE
1	NC13-33-0005	2	STICKER MAXIMUM 540 RPM
2	NC13-33-0187	2	STICKER DANGER (PTO AND PERSON)
3	NC13-33-0344	1	ADJUSTEMENT INDICATOR STICKER
4	NC13-33-0248	1	STICKER IMPORTANT 4 1/4 INCHES 110mm
5	NC13-33-0281	1	STICKER SHEAR BOLT
6	NC13-33-0183	1	STICKER CAUTION OPERATION MANUAL
7	NC13-33-0329	1	STICKER 2886-D
8	NC13-33-0189	1	STICKER DANGER (PERSON AND CHAIN DRIVE)
9	NC13-33-0241	1	STICKER MAX-SNOW COMMERCIAL
10	NC13-33-0024	6	STICKER GREASE HERE
11	NC13-33-0001	2	STICKER AGRIMETAL
12	NC13-50-0086	1	SERIAL NUMBER PLATE
13	NC13-33-0317	1	STICKER GREASE DRIVE LINE TELESCOPIC SHAFT
14	NC13-33-0274	1	STICKER DANGER
15	NC13-33-0283	1	STICKER DANGER (PERSON AND CHAIN DRIVE)
16	NC13-33-0343	1	GREASE CHAIN EVERY 10 HOURS STICKER
17	NC13-33-0326	1	STICKER DANGER (HAND)
18	NC13-33-0327	1	STICKER END ROTATION ADJUSTMENT
19	NC13-33-0192	2	STICKER (PROJECTION RISK)
20	NC13-33-0249	3	STICKER DANGER

**AGRIMETAL****MS 2792-D**

CREATION : 06/06/19  
 REVISION : 13/12/19

ASSEMBLY : **81-99-5500**

AUTHOR : F.HÉLIE

Page 22 de 22