

AgriMetal

PARTS LIST

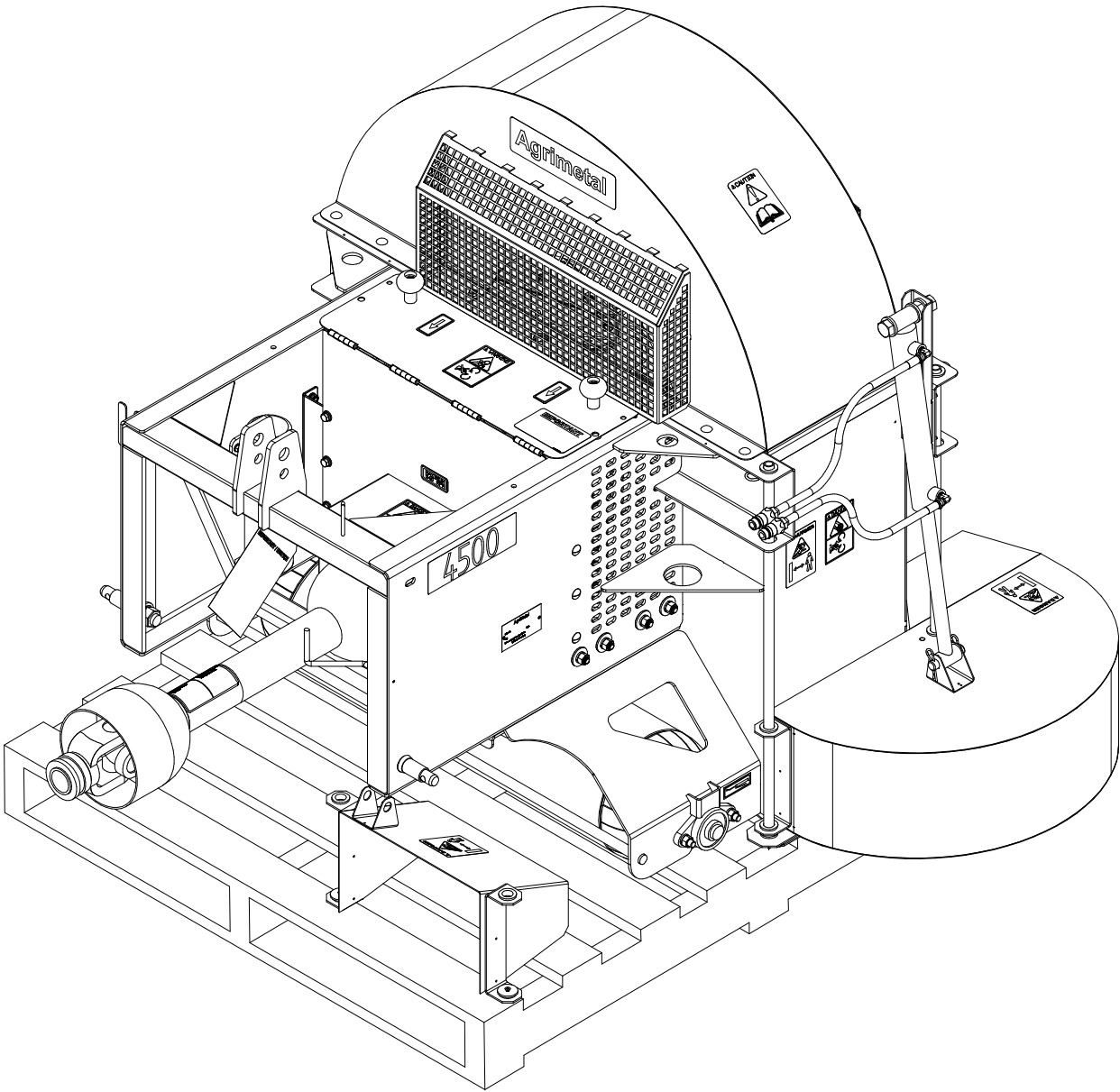

BW 4500 TP

#	PART #	Qty	TITLE
1	NCI7-46-0023	4	BUSHING 0.810" ID X 1.310" OD X 0.460"
2	25-55-0710	1	SERIAL NUMBER PLATE

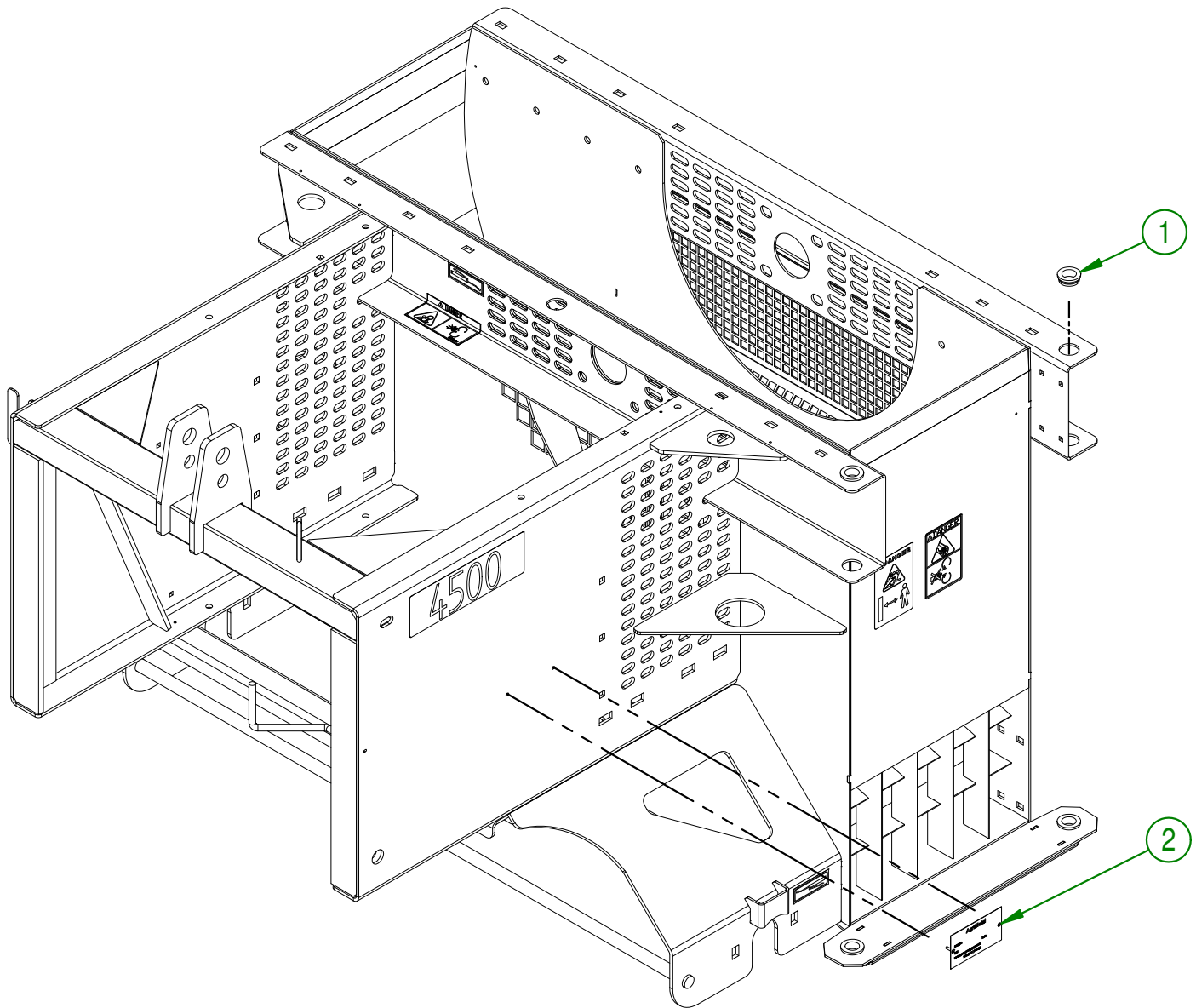

AGRIMETAL	
ASSEMBLY CASING	
CREATION : 02/03/17	ASSEMBLY : 32-57-2000
REVISION : 19/09/18	AUTHOR : F.HÉLIE
	Page 1 de 15

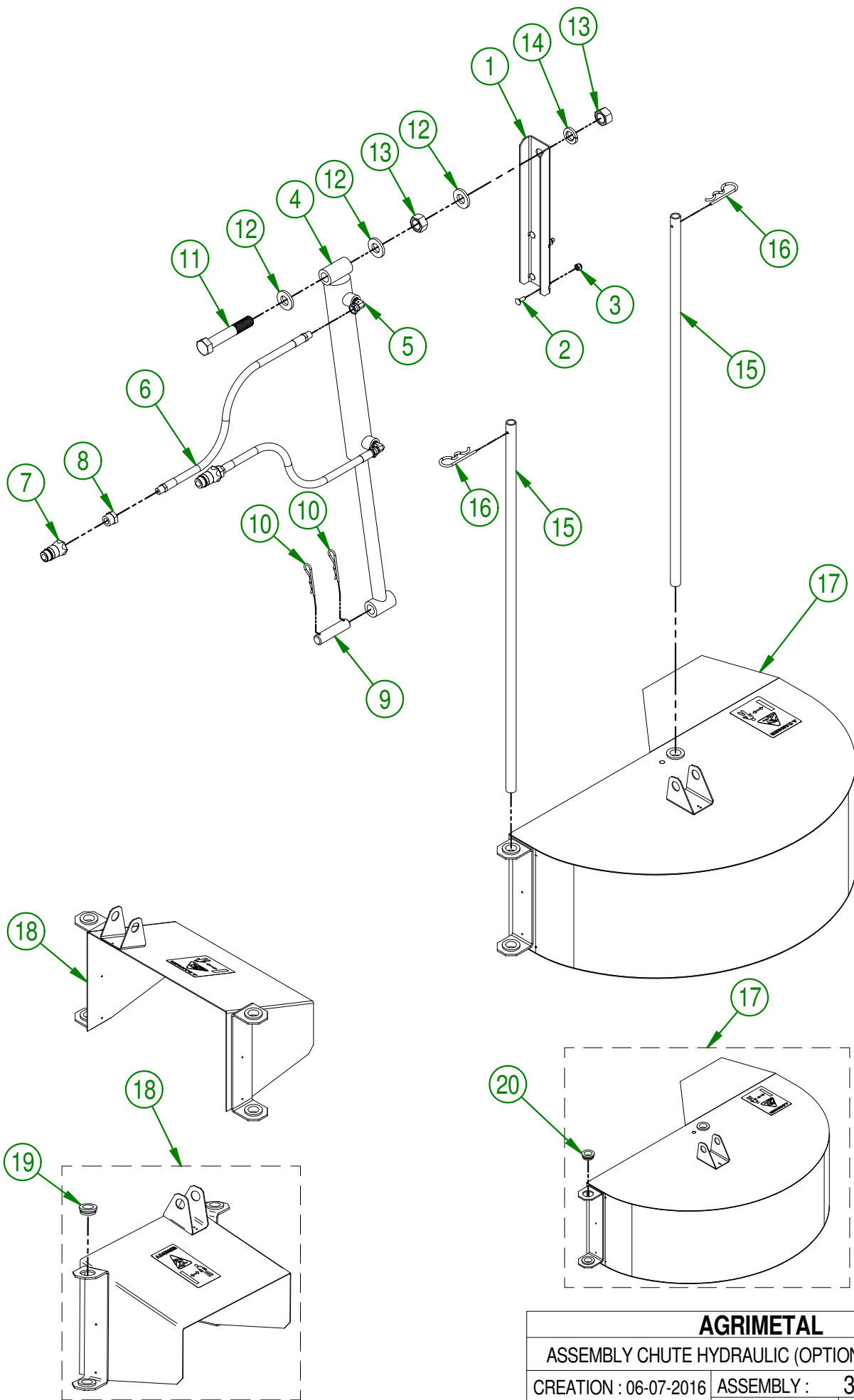

AGRIMETAL		
ASSEMBLY CHUTE HYDRAULIC (OPTION)		
CREATION : 06-07-2016	ASSEMBLY :	32-57-1090
REVISION : 06-03-2019	AUTHOR :	Page 2 de 15

32-57-1090

#	PART #	QTY	TITLE
1	32-01-7550	1	CYLINDER BRACKET
2	NC01-04-0002	4	CARR. BOLT GR2 ZINC 1/4-20 X 5/8"
3	NC01-96-0009	4	NYLON-INSERT LOCKNUT ZINC 1/4-20
4	NC13-45-0148	1	HYDRAULIC CYL. 2" OD X 1" ROD X 18" OPEN X 10" TRAVEL
5	NC13-45-0026	2	90° Elbow - 7/16-20 MALE SAE 4 O-RINGS X 1/4 FEM.
6	NC17-02-0319	2	HYD. PIPE BOYAU HYD. 1/4" X 84 " CUT 1/4 NPT MALE RIG. X 1/4 NPT MALE RIG.
7	NC13-45-0014	2	QUICK COUPLER 1/2-14 NPTF
8	NC13-45-0153	2	HEX. REDUCER 1/4 NPT X 1/2 NPT
9	32-21-0015	1	CYLINDER PIN
10	NC01-63-0015	2	COTTER PIN Z 1/8" X 2 5/8"
11	NC01-17-0478	1	BOLT HEX. GR2 ZINC 3/4-10 X 4 1/2"
12	22-04-6805	3	FLAT WASHER BEARING BASE
13	NC02-07-0023	2	HEX. NUT ZINC 3/4-10
14	NC02-32-0017	1	LOCK WASHER ZINC 3/4"
15	32-11-2500	2	CHUTE GUIDE
16	NC01-63-0026	2	COTTER PIN ZC 5/32" X 3"
17	32-55-1075	1	ASSEMBLY LARGE CHUTE
18	32-55-1080	1	ASSEMBLY SMALL CHUTE

32-55-1080

#	PART #	QTY	TITLE
19	NC17-46-0023	4	BUSHING 0.810" ID X 1.310" OD X 0.460"

32-55-1075

#	PART #	QTY	TITLE
20	NC17-46-0023	4	BUSHING 0.810" ID X 1.310" OD X 0.460"

AGRIMETAL

ASSEMBLY CHUTE HYDRAULIC (OPTION)

CREATION : 06-07-2016	ASSEMBLY :	32-57-1090
REVISION : 06-03-2019	AUTHOR :	Page 3 de 15

#	# DE PIÈCE	Qty	TITLE
1	32-46-0005	1	FRONT ROLLER
2	NC14-75-0020	2	FLANGE PILLOW BLOCK BEARING UCFL206-18 Ø 1 1/8"
3	NC01-04-0235	4	CARR. BOLT GR2 ZINC 1/2-13 X 1 1/2"
4	NC02-32-0014	4	LOCK WASHER ZINC 1/2"
5	NC02-07-0020	4	HEX. NUT ZINC 1/2-13
6	NC13-80-0061	4	PAD STEEL POWDER 1/2" X 5/8" X 3/8"

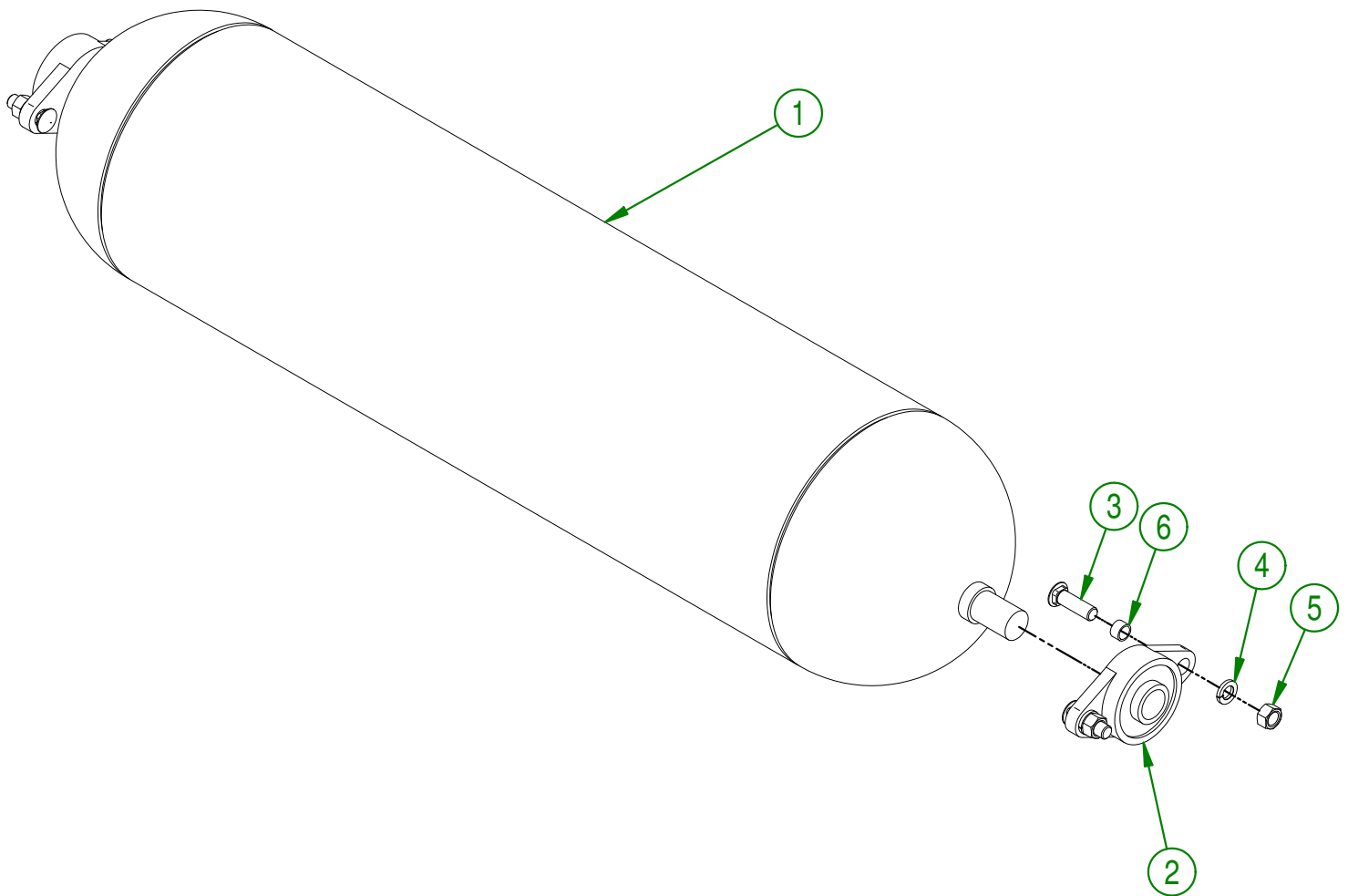

AGRIMETAL		
FRONT TURF ROLLER GROUP		
CREATION : 17-06-2016	ASSEMBLY :	32-57-1025
REVISION : 13-11-2018	AUTHOR : S.B.	Page 4 de 15

32-57-1030

#	PART #	Qty	TITLE
1	32-55-1070	1	ASSEMBLY TURF ROLLER (REAR)
2	32-50-1055	1	LEFT SMALL TURF ROLLER SUPPORT
3	32-50-1060	1	RIGHT SMALL TURF ROLLER SUPPORT
4	NC01-04-0107	8	CARR. BOLT GR2 ZINC 3/8-16 X 3/4"
5	NC02-14-0019	8	FLANGE NUT HEX. NC 3/8-16 GR. B

32-55-1070

#	PART #	Qty	TITLE
6	32-11-3510	1	TURF ROLLER ONLY (REAR)
7	32-42-0105	2	REAR ROLL CAP

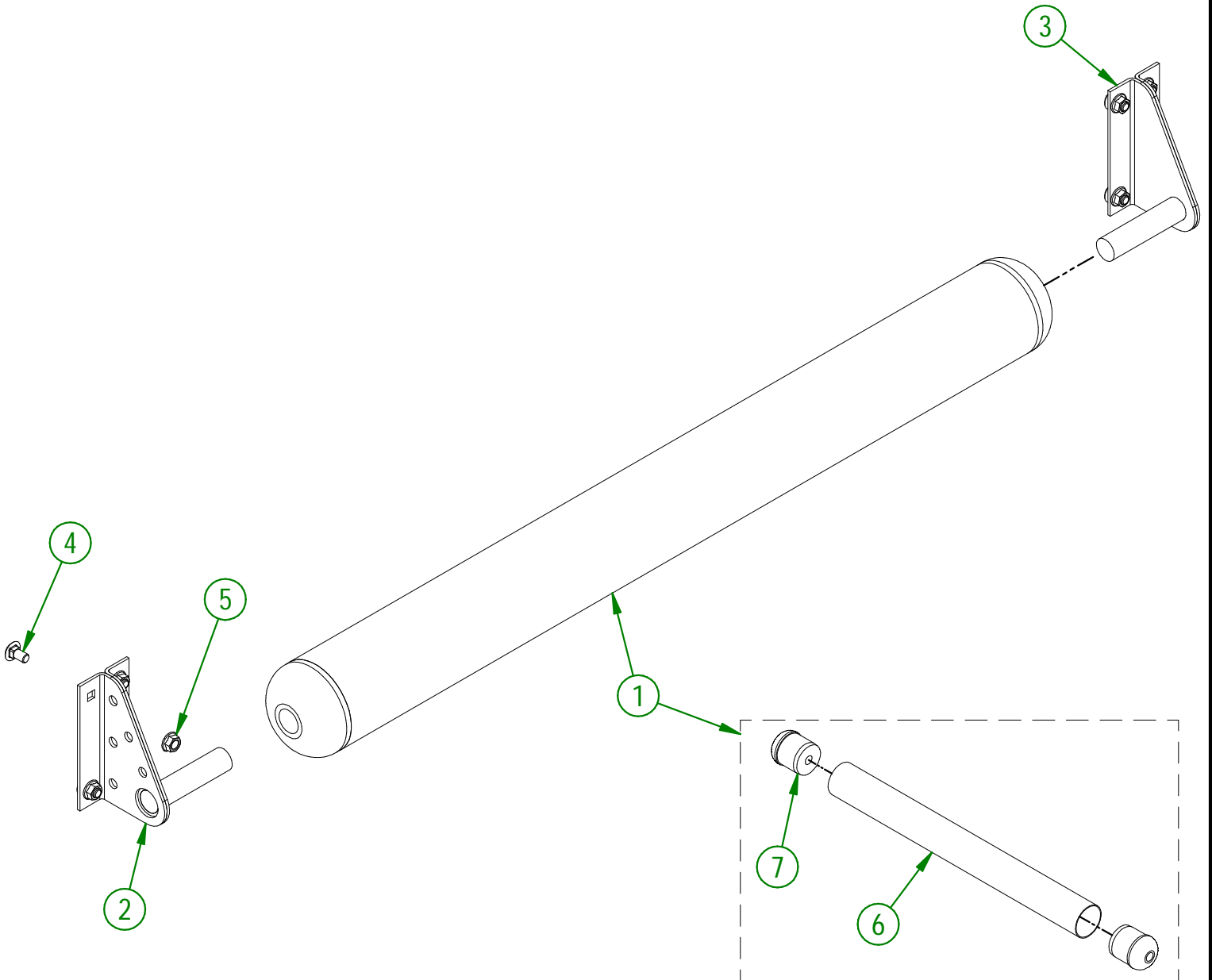

AGRIMETAL	
ASSEMBLY TURF ROLLER GROUP.	
CREATION : 2016-06-17	ASSEMBLY : 32-57-1030
REVISION : 2024-02-13	AUTHOR :

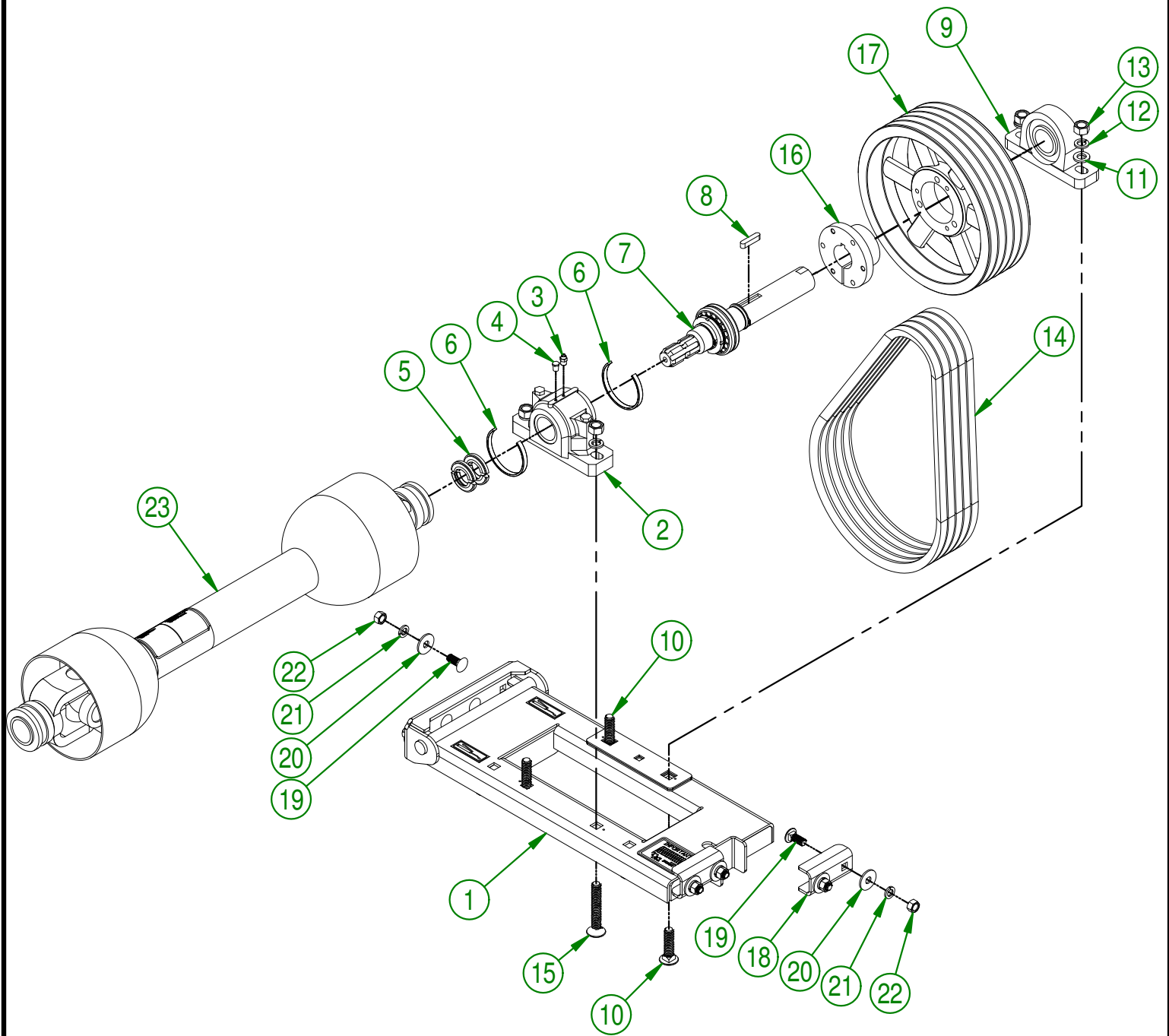

AGRIMETAL
BEARING BASE GROUP

CREATION : 09/03/17
 REVISION : 27/09/18

ASSEMBLY : **32-57-2045**

AUTHOR : F.HÉLIE

Page 6 de 15

#	PART #	Qty	TITLE
1	32-57-1047	1	BEARING BASE ASSEMBLY
2	NC14-75-0124	1	PILLOW BLOCK BEARING I 3/4"
3	NC01-69-0791	1	GREASE FITTING 1/8 NPT STRAIGHT
4	NC01-64-0241	1	BRASS PLUG HEX. 1/8 NPT
5	NC14-75-0123	1	SET JOINT I 3/4"
6	NC14-75-0122	2	BEARING SPACER I 3/4"
7	32-55-1063	1	ASSEMBLY DRIVE SHAFT
8	NC01-65-0100	1	KEY 3/8 X 3/8 X I 3/4"
9	NC14-75-0115	1	PILLOW BLOCK UCP209-28 Ø I 3/4"
10	NC01-04-0270	2	CARR. BOLT GR2 ZINC 5/8 - 11 X 2 1/2"
11	32-01-1395	2	BEARING WHASER Ø 3/4"
12	NC02-32-0016	4	LOCK WASHER ZINC 5/8"
13	NC02-07-0022	4	HEX. NUT ZINC 5/8-11
14	NC14-25-1090	5	V BELT 21/32 COGED RAW EDGE BX-51
15	NC01-04-0276	2	BOLT CARR. GR2 ZINC 5/8-11 X 4"
16	NC14-62-0013	1	QD BUSHING SF I 3/4"
17	NC14-62-0196	1	PULLEY QD 5VI/2-5/8 X 12.75 DE X SF 5BI24
18	32-04-0080	2	STOPPER BEARING BASE
19	NC01-04-0234	8	CARR. BOLT GR2 ZINC 1/2-13 X I 1/4
20	01-01-1660	8	WASHER SPACER
21	NC02-32-0014	8	LOCK WASHER ZINC 1/2"
22	NC02-07-0020	8	HEX. NUT ZINC 1/2-13
23	32-34-0030	1	PTO SHAFT

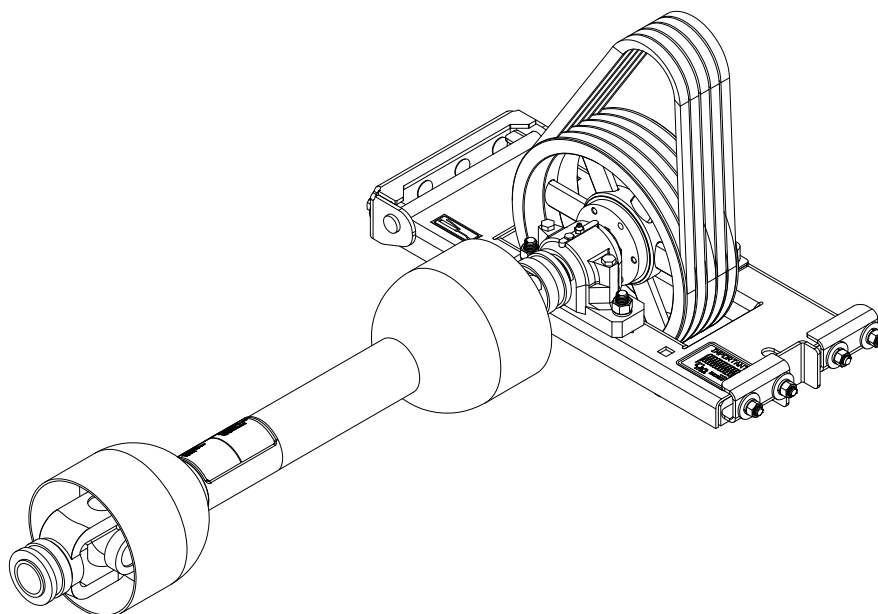

AGRIMETAL
BEARING BASE GROUP

CREATION : 09/03/17
REVISION : 27/09/18

ASSEMBLY : **32-57-2045**

AUTHOR : F.HÉLIE

Page 7 de 15

#	PART #	Qty	TITLE
1	NC01-17-0112	6	HEX. BOLT GR2 ZINC 3/8-16 X 3/4"
2	NC02-32-0012	8	LOCK WASHER ZINC 3/8"
3	01-01-2485	8	FLAT WASHER
4	NC01-17-0119	2	HEX. BOLT GR2 ZINC 3/8-16 X 2 1/4"
5	NC02-07-0018	2	HEX. NUT ZINC 3/8-16
6	NC17-46-0018	2	HANDLE KNOB
7	32-57-1050	1	ASSEMBLY BELT GUARD
8	NC01-04-0055	2	CARR. BOLT GR2 ZINC 5/16-18 X 5/8"
9	NC01-96-0010	2	NYLON NUT HEX. ZINC 5/16-18

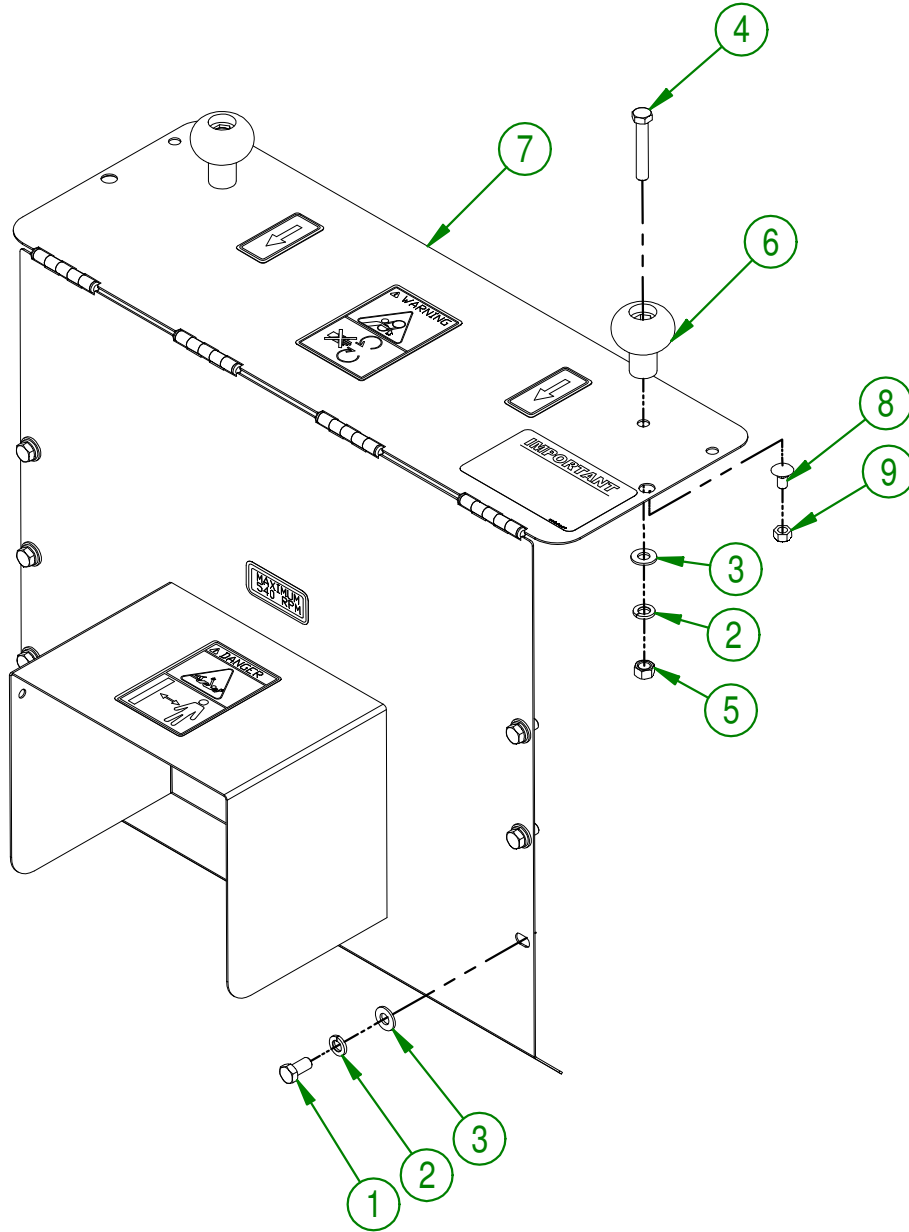

AGRIMETAL		
ASSEMBLY BELT GUARD		
CREATION : 2016-06-17	ASSEMBLY :	32-57-1085
REVISION : 2018-01-08	AUTHOR :	Page 8 de 15

#	# DE PIÈCE	Qty	TITLE
1	32-50-1020	1	TENSIONER THREADED ROD
2	22-04-6805	1	FLAT WASHER BEARING BASE
3	NC02-07-0023	2	HEX. NUT ZINC 3/4-10
4	32-01-3070	1	HANDLE
5	32-42-0125	1	SPRING STOPPER
6	32-42-0100	1	SPRING GUIDE
7	12-44-0015	1	RED SPRING 1 1/2" OD 1" ID X 8 1/2"

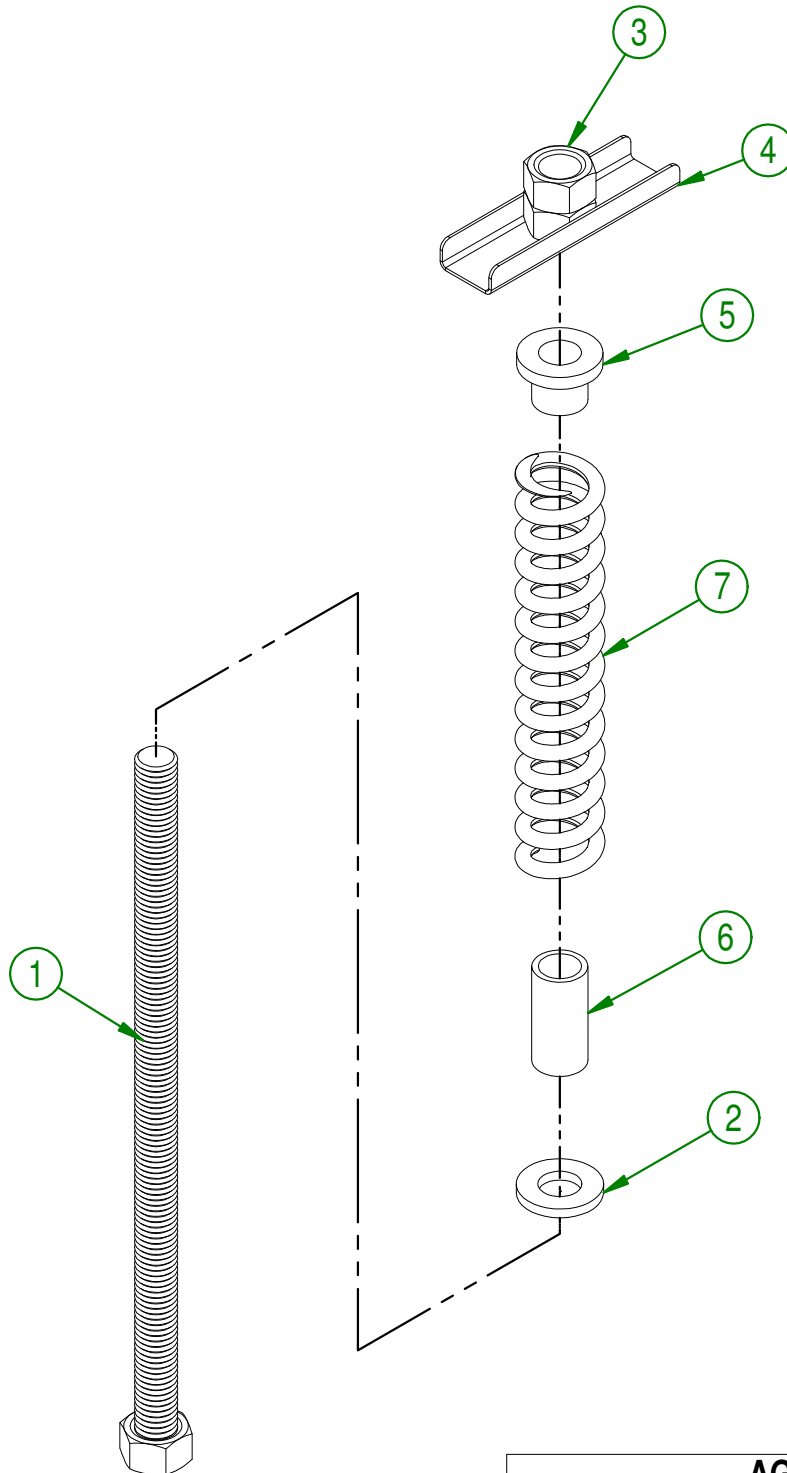

AGRIMETAL			
ASSEMBLY BELT TENSIONER			
CREATION : 2016-06-17	ASSEMBLY :	32-57-1035	
REVISION : 2018-01-04	AUTHOR : S.B.	Page 9 de 15	

#	# DE PIÈCE	Qty	TITLE
1	32-50-1040	2	BELT GUARD BRACKET
2	NC01-04-0107	6	CARR. BOLT GR2 ZINC 3/8-16 X 3/4"
3	NC02-32-0012	6	LOCK WASHER ZINC 3/8"
4	NC02-07-0018	6	HEX. NUT ZINC 3/8-16

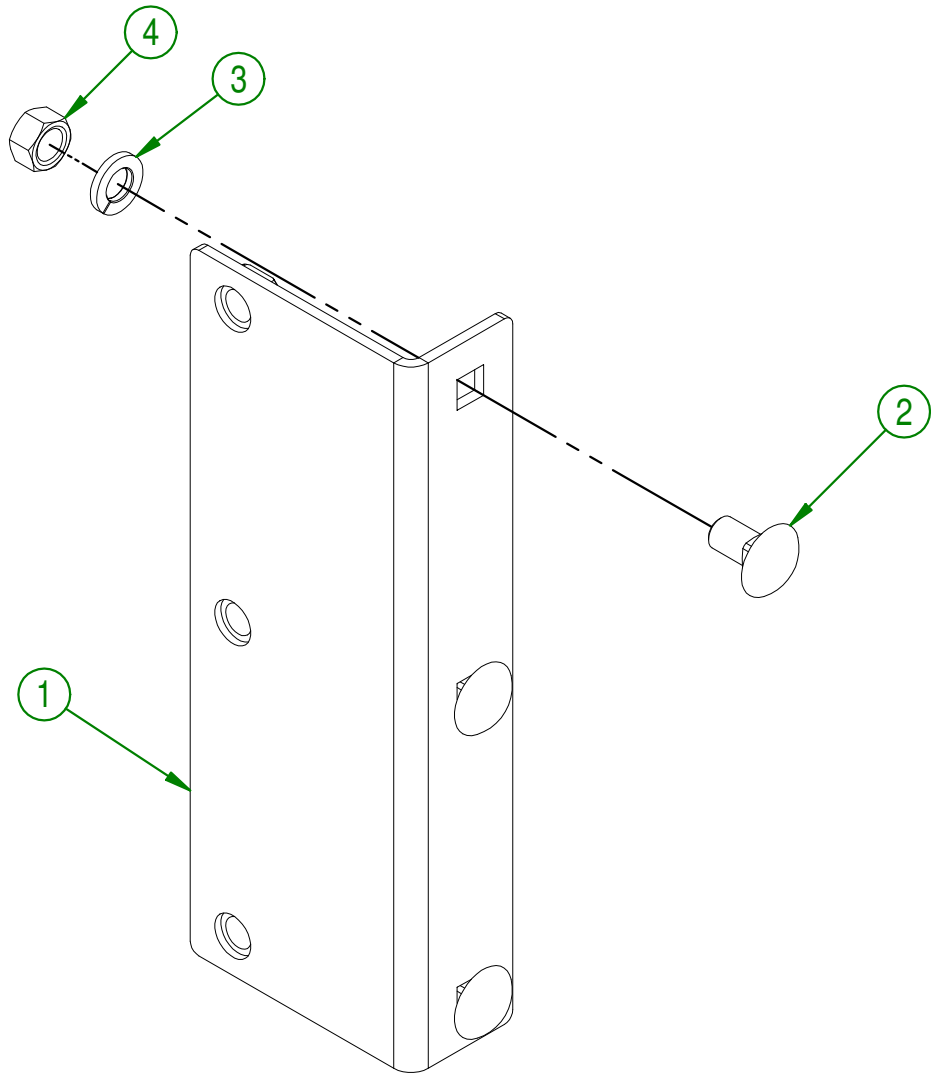

AGRIMETAL			
ASSEMBLY BRACKET BELT GUARD			
CREATION : 2016-06-17	ASSEMBLY :	32-57-1055	
REVISION : 2018-01-04	AUTHOR : S.B.	Page 10 de 15	

#	PART #	Qty	TITLE
1	32-13-2800	1	DRIVE SHAFT PROPELLER
2	32-55-1050	1	PROPELLER
3	32-09-1900	3	POSITION SLEEVE
4	NC14-75-0026	1	FLANGE BEARING 4 HOLES UCF 209-28 X I 3/4"
5	NC14-75-0025	1	FLANGE BEARING 4 HOLES UCF 208-24 X I 1/2"
6	32-03-3610	1	REAR BEARING PROTECTOR
7	NC01-17-0396	8	HEX. BOLT GR2 ZINC 5/8-11 X 2"
8	NC02-22-0013	4	WASHER ZINC 5/8 ID X I 1/2 OD
9	NC02-32-0016	8	LOCK WASHER ZINC 5/8"
10	NC02-07-0022	8	HEX. NUT ZINC 5/8-11
11	NC14-62-0195	1	PULLEY QD 5V 1/2-5/8 X 5.35 DE X SD (5B50)
12	NC14-62-0008	1	QD BUSHING SD I 3/4"
13	NC02-14-0626	1	HEX LOCKNUTS I 5/8"-12
14	NC01-65-0307	1	KEY
15	32-41-0900	1	IMPELLER KEY

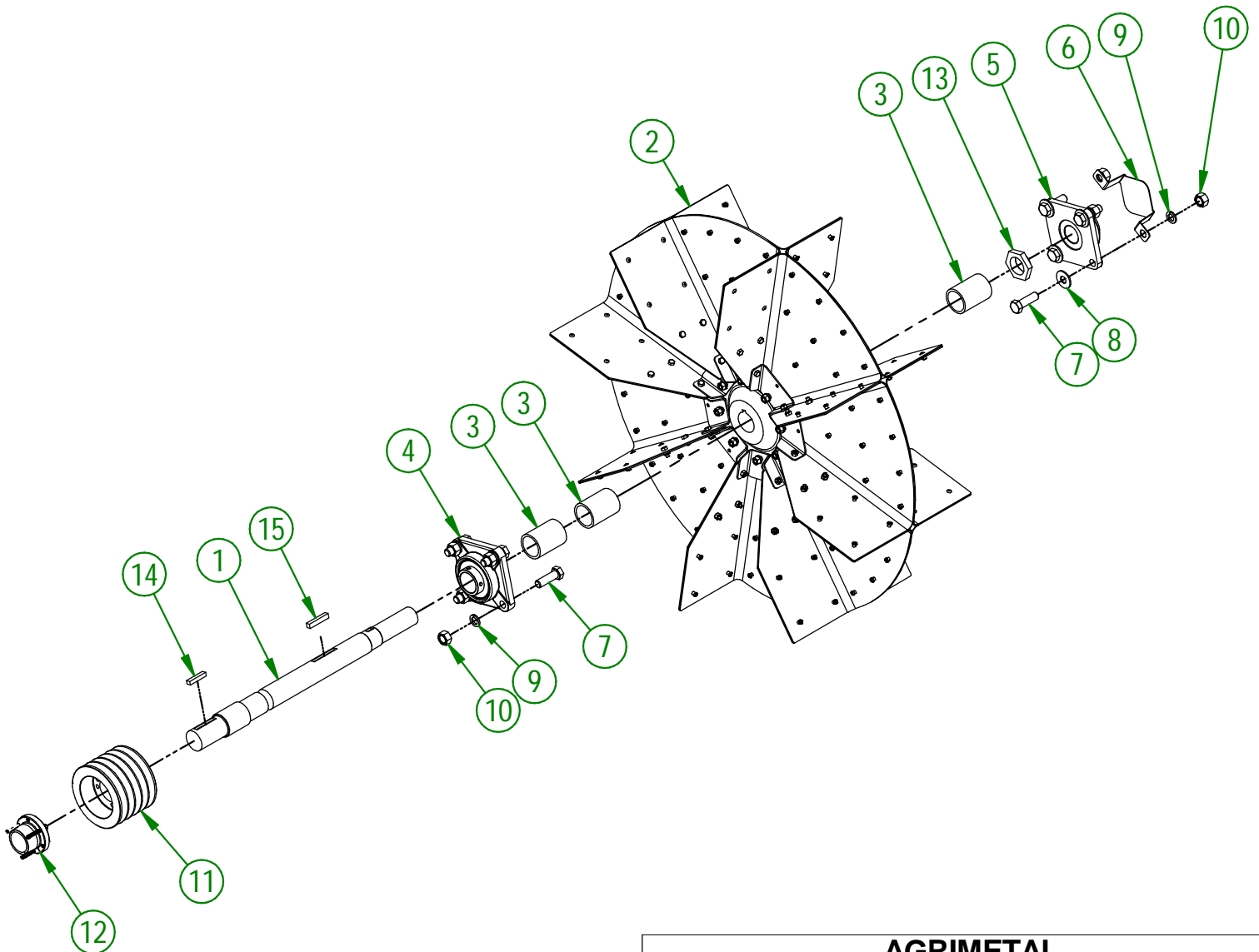

AGRIMETAL	
ASSEMBLY DRIVE SHAFT PROPELLER	
CREATION : 08/03/17	ASSEMBLY : 32-57-2020
REVISION : 15/02/24	AUTHOR : F.HÉLIE

#	PART #	Qty	TITLE
1	32-57-2005	1	ASSEMBLY CASING COVER
2	NC01-04-0107	10	CARR. BOLT GR2 ZINC 3/8-16 X 3/4"
3	NC02-14-0019	14	FLANGE NUT HEX. NC 3/8-16 GR. B

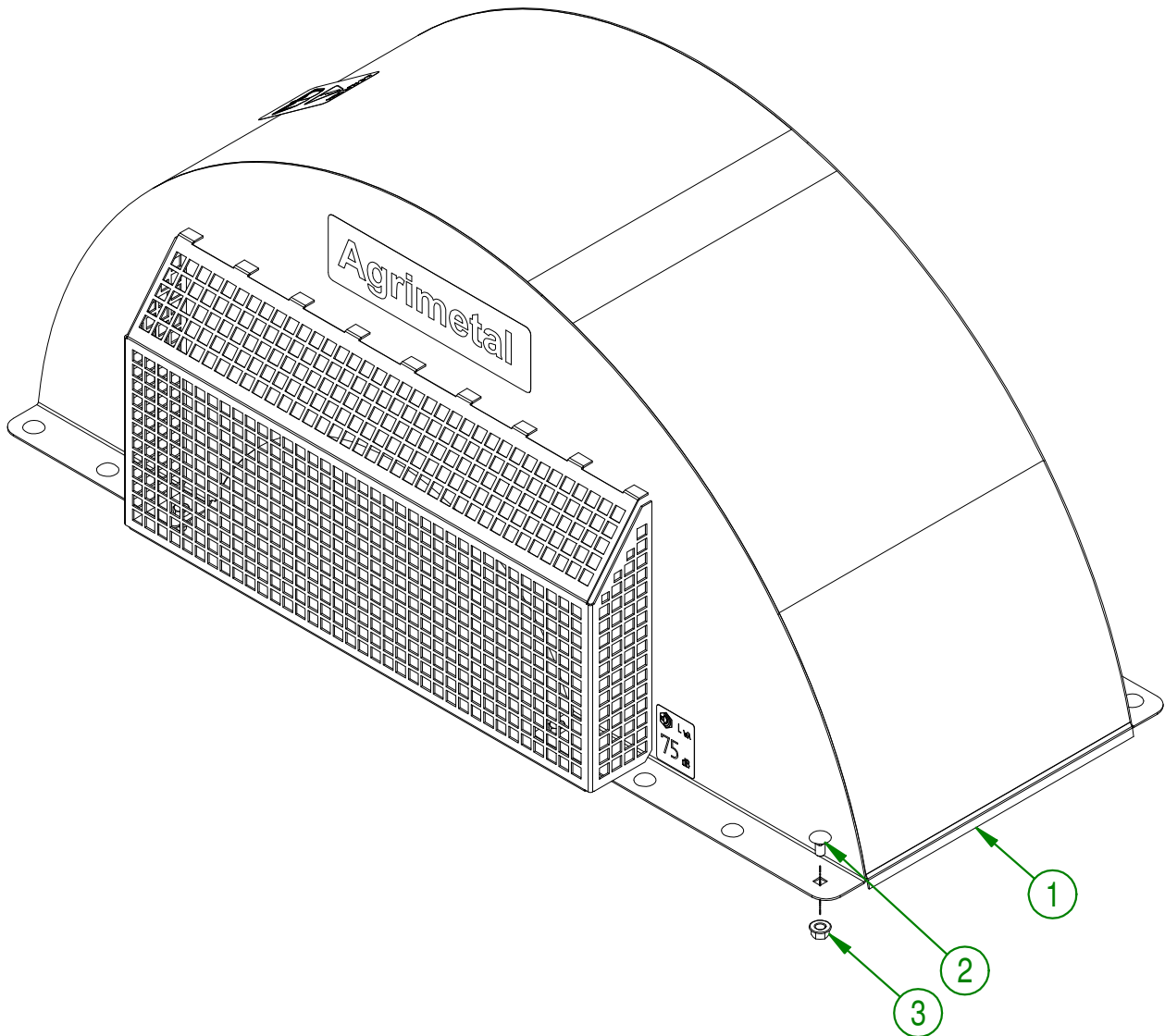

AGRIMETAL	
ASSEMBLY COVER CASING	
CREATION : 08/03/17	ASSEMBLY : 32-57-2040
REVISION : 04/01/18	AUTHOR : F.HÉLIE Page 12 de 15

#	PART #	Qty	TITLE
1	NC01-78-0002	1	3 POINTS PIN 1/8-14 X 5 1/4"
2	09-04-0050	1	PNO 3/16" X 1 49/64" DIA. X Ø 7/8" FLAT WASHER
3	32-09-2005	1	HITCH CONVERSION BUSHING (CATEGORY 2)

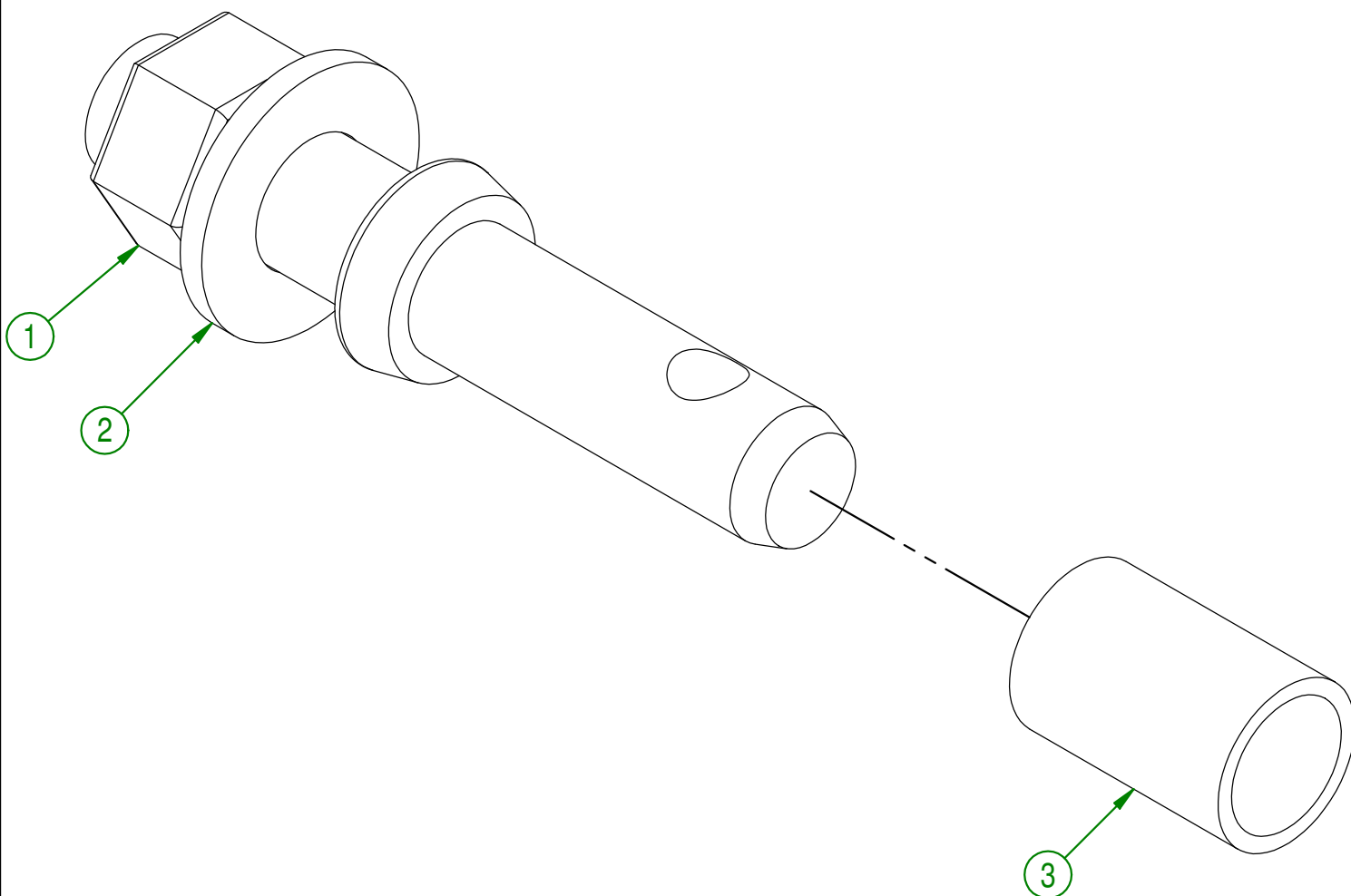

AGRIMETAL	
ASSEMBLY 3 POINTS PIN	
CREATION : 30/11/17	ASSEMBLY : 32-57-0096
REVISION : 04/01/18	AUTHOR : F.HÉLIE Page 13 de 15

#	PART #	Qty	TITLE
1	NC13-30-0237	1	PLASTIC TUBE FOR OPERATOR'S MANUAL
2	NC01-04-0003	3	BOLT CARR. GR2 ZINC 1/4-20 X 3/4"
3	NC02-25-0007	3	WASHER ZINC 0.281 = 9/32
4	NC01-96-0009	3	NYLON-INSERT LOCKNUT ZINC 1/4-20
5	32-98-0626	1	OPERATOR MANUAL BW 2500-3500-4500

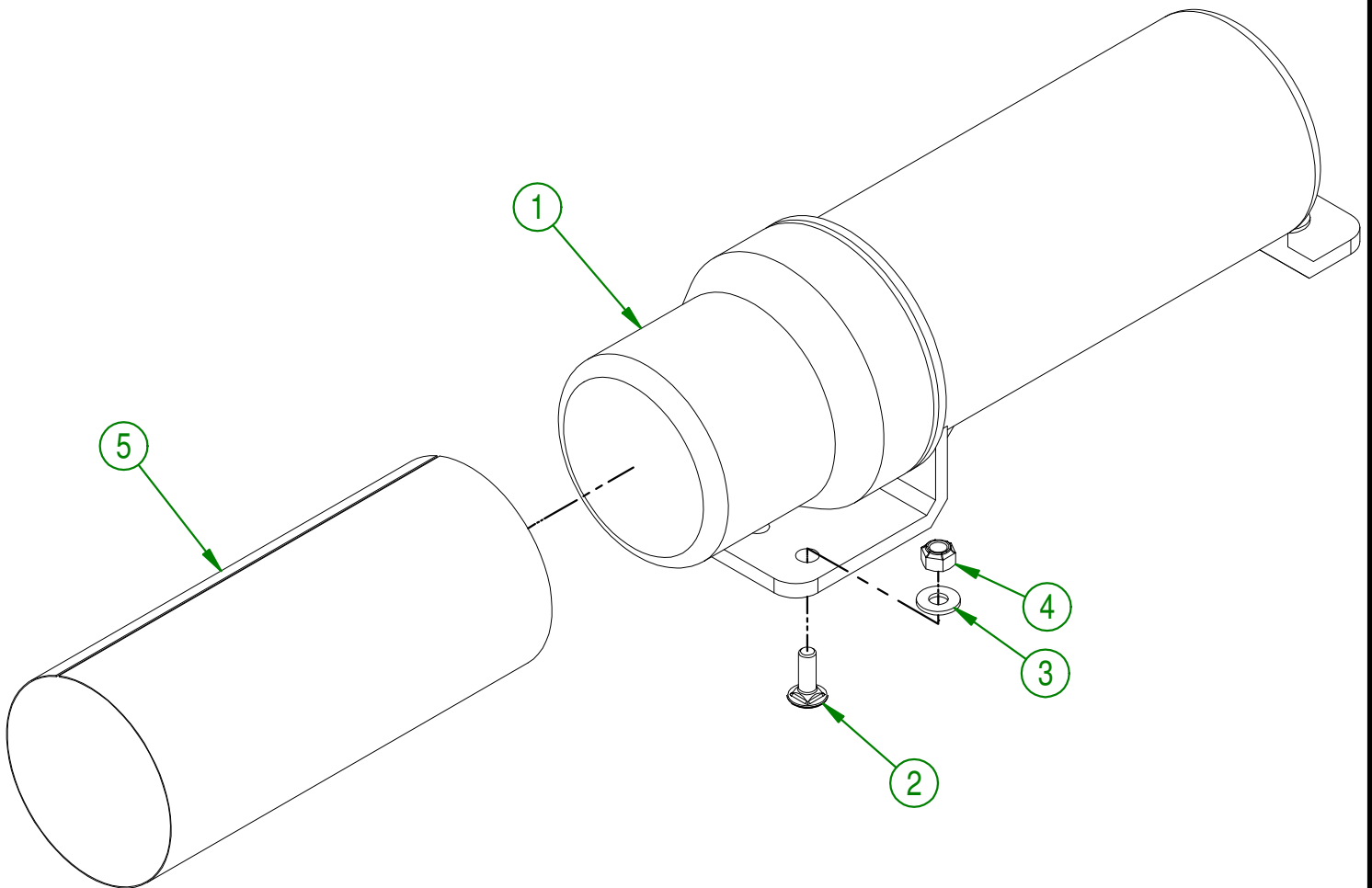

AGRIMETAL
OPERATOR MANUEL

CREATION : 13/03/17
 REVISION : 05/01/18

ASSEMBLY : **32-57-1105**

AUTHOR : F.HÉLIE Page 14 de 15

#	PART #	QTY	TITLE
1	NCI3-33-0186	1	STICKER (DANGER)
2	NCI3-33-0192	3	STICKER (PROJECTION RISK)
3	NCI3-33-0161	2	STICKER 4500
4	NCI3-33-0024	6	STICKER GREASE HERE
5	NCI3-33-0290	1	STICKER DANGER
6	NCI3-33-0163	1	STICKER LOW DECIBEL
7	NCI3-33-0154	1	STICKER IMPORTANT
8	NCI4-85-0276	1	STICKER (DANGER-PLASTIC GUARD)
9	NCI3-33-0035	2	STICKER AGRIMETAL
10	NCI3-33-0305	1	STICKER 75 dB
11	NCI3-33-0183	1	STICKER CAUTION OPERATION MANUAL
12	NCI3-33-0005	1	STICKER MAXIMUM 540 RPM
13	NCI3-33-0287	1	STICKER WARNING
14	NCI3-33-0298	2	STICKER PULL THIS WAY TO OPEN
15	NCI3-33-0179	1	STICKER IMPORTANT GREASE DRIVE LINE
16	NCI3-33-0187	1	STICKER DANGER (PTO AND PERSON)

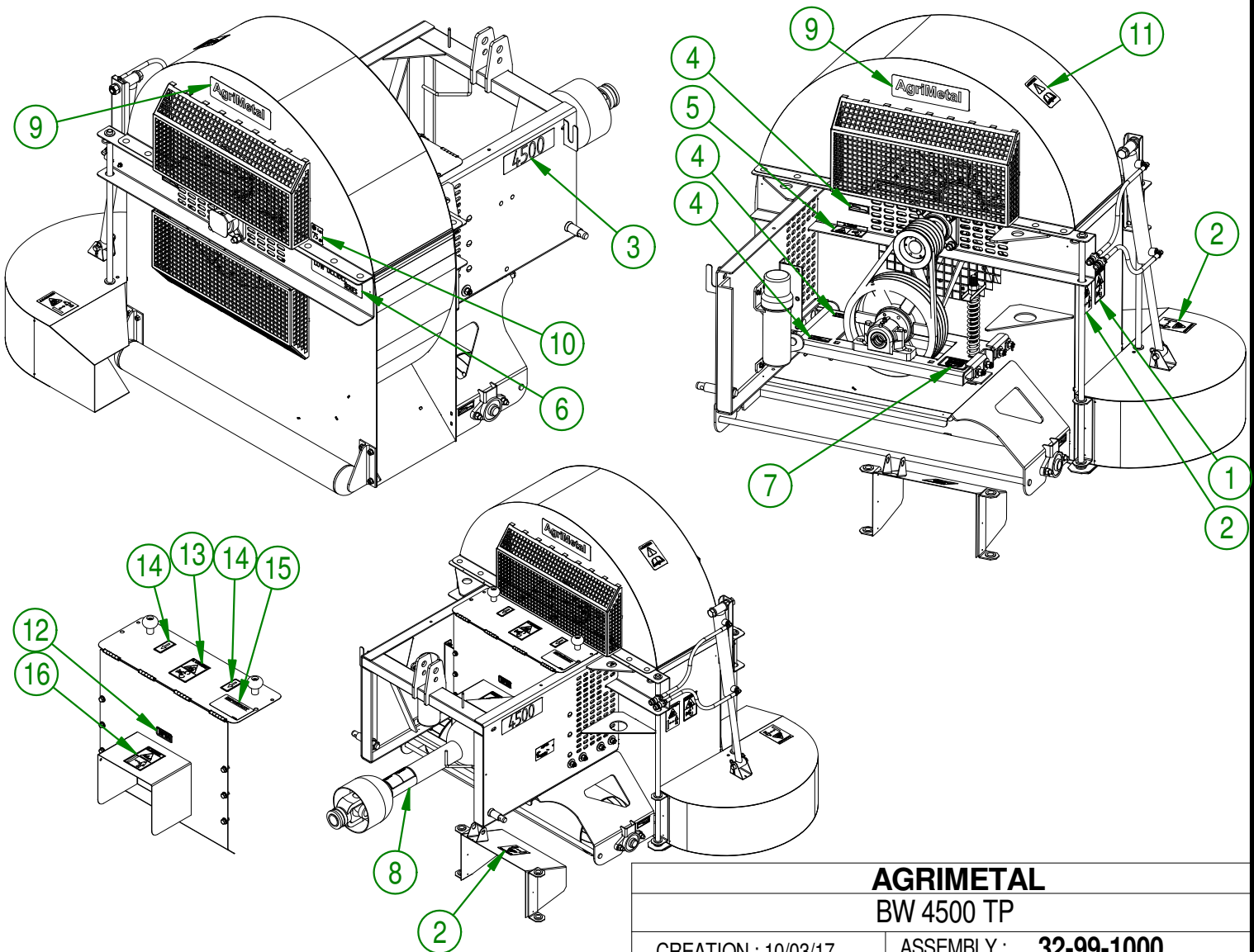

AGRIMETAL
BW 4500 TP

CREATION : 10/03/17
REVISION : 19/09/18

ASSEMBLY : **32-99-1000**

AUTHOR : F.HÉLIE Page 15 de 15