

# AgriMetal

## PARTS LIST

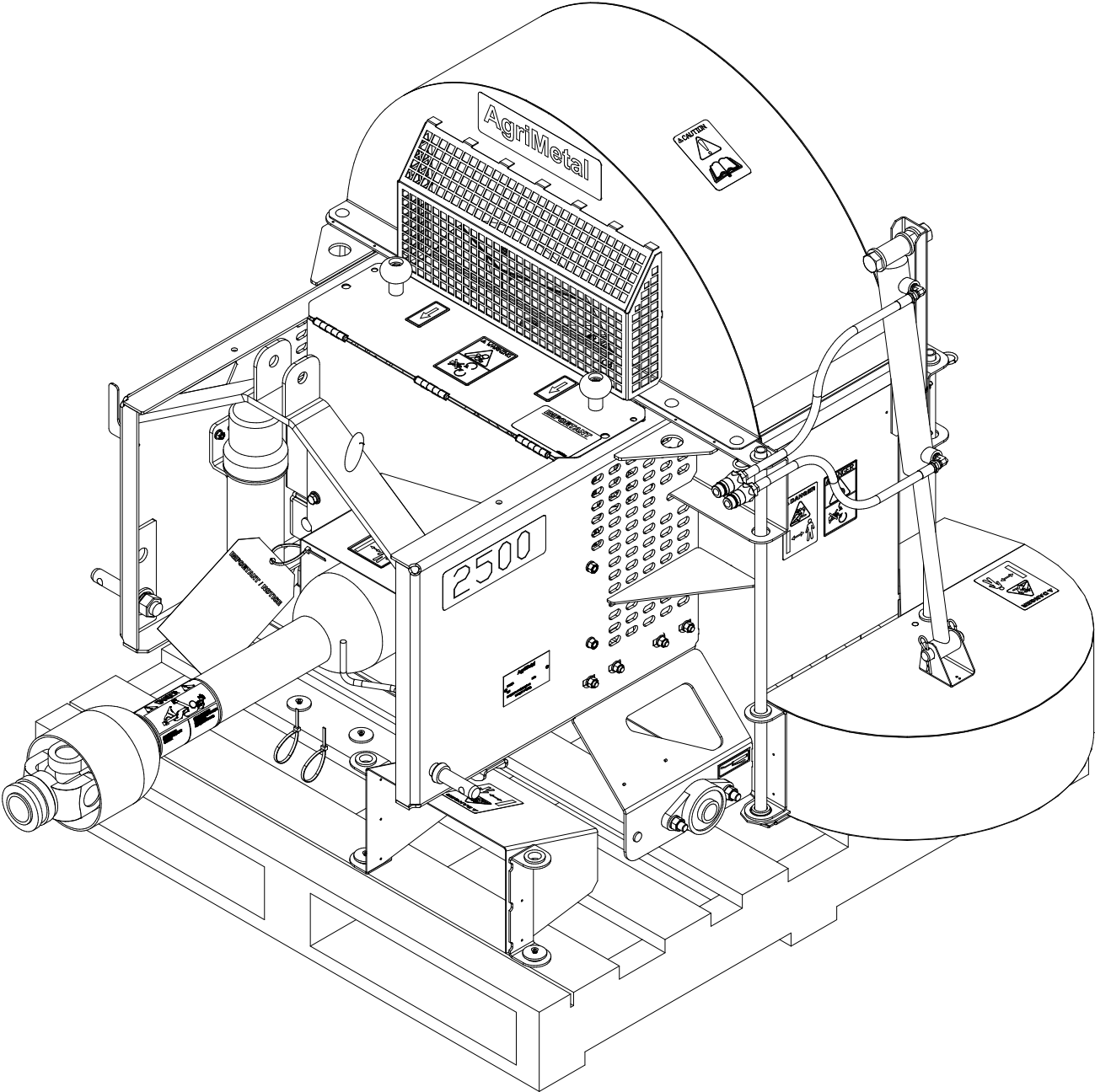

**BW 2500**

#	PART #	Qty	TITLE
1	NC17-46-0023	4	BUSHING 0.810" ID X 1.310" OD X 0.460"
2	25-55-0710	1	SERIAL NUMBER PLATE

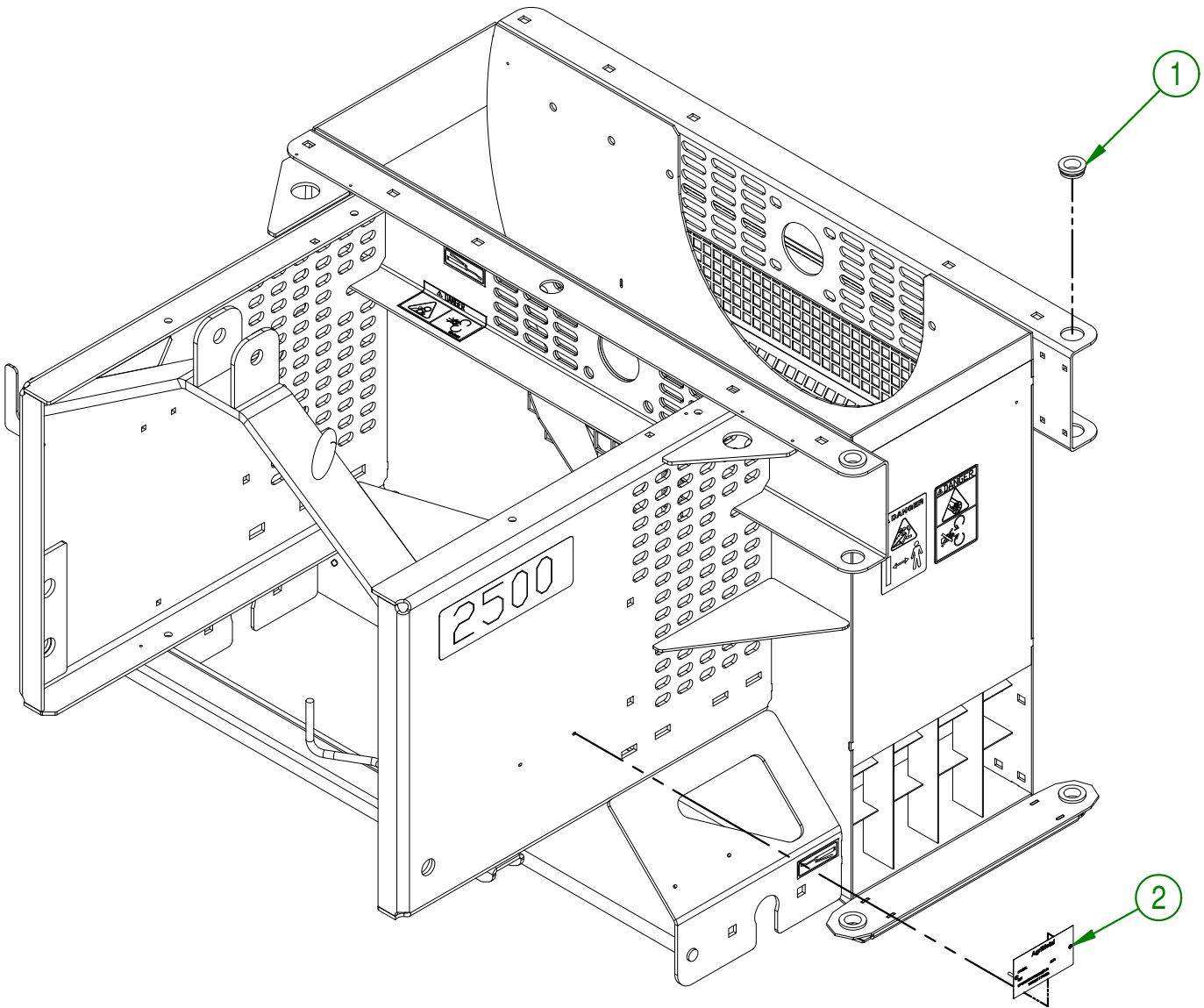

<b>AGRIMETAL</b>			
<b>ASSEMBLY CASING</b>			
CREATION : 21-06-2016	ASSEMBLY :	32-57-3010	
REVISION : 06-02-2019	AUTHOR : S.B.	Page 1 de 15	

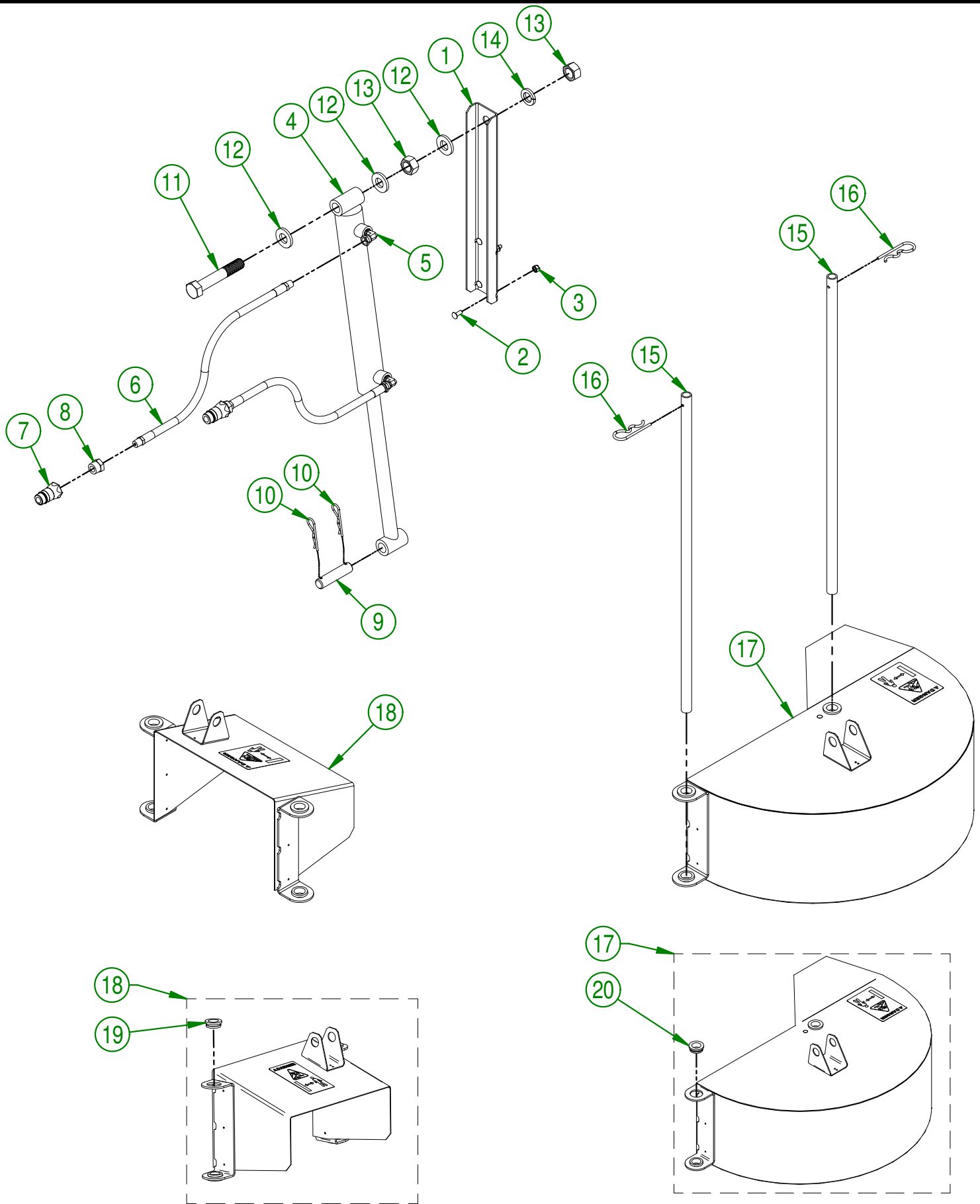

<b>AGRIMETAL</b>	
<b>HYDRAULIC DEFLECTOR 1° TO 180° (OPTION)</b>	
CREATION : 26/01/18	ASSEMBLY : <b>32-57-3000</b>
REVISION : 06/03/19	AUTHOR : F.HÉLIE      Page 2 de 15

## 32-57-3000

#	PART #	Qty	TITLE
1	32-01-7565	1	CYLINDER BRACKET
2	NC01-04-0002	4	CARR. BOLT GR2 ZINC 1/4-20 X 5/8"
3	NC01-96-0009	4	NYLON-INSERT LOCKNUT ZINC 1/4-20
4	NC13-45-0148	1	HYDRAULIC CYL. 2" OD X 1" ROD X 18" OPEN X 10" TRAVEL
5	NC13-45-0026	2	90° Elbow - 7/16-20 MALE SAE 4 O-RINGS X 1/4 FEM.
6	NC17-02-0319	2	HYD. PIPE BOYAU HYD. 1/4" X 84 " CUT 1/4 NPT MALE RIG. X 1/4 NPT MALE RIG.
7	NC13-45-0014	2	QUICK COUPLER 1/2-14 NPTF
8	NC13-45-0153	2	HEX. REDUCER 1/4 NPT X 1/2 NPT
9	32-21-0015	1	CYLINDER PIN
10	NC01-63-0015	2	COTTER PIN Z 1/8" X 2 5/8"
11	NC01-17-0478	1	BOLT HEX. GR2 ZINC 3/4-10 X 4 1/2"
12	22-04-6805	3	FLAT WASHER BEARING BASE
13	NC02-07-0023	2	HEX. NUT ZINC 3/4-10
14	NC02-32-0017	1	LOCK WASHER ZINC 3/4"
15	32-11-2505	2	DEFLECTOR GUIDE
16	NC01-63-0026	2	COTTER PIN ZC 5/32" X 3"
17	32-55-3075	1	ASSEMBLY DEFLECTOR
18	32-55-3080	1	ASSEMBLY SMALL DEFLECTOR (OPTION)

## 32-55-3080

#	PART #	QTY	TITLE
19	NC17-46-0023	4	BUSHING 0.810" ID X 1.310" OD X 0.460"

## 32-55-3075

#	PART #	QTY	TITLE
20	NC17-46-0023	4	BUSHING 0.810" ID X 1.310" OD X 0.460"

**AGRIMETAL**

HYDRAULIC DEFLECTOR 1° TO 180° (OPTION)

CREATION : 26/01/18  
REVISION : 06/03/19ASSEMBLY : **32-57-3000**

AUTHOR : F.HÉLIE

Page 3 de 15

#	PART #	Qty	TITLE
1	32-46-0000	1	FRONT ROLLER
2	NC13-80-0061	4	PAD STEEL POWDER 1/2" X 5/8" X 3/8"
3	NC02-32-0014	4	LOCK WASHER ZINC 1/2"
4	NC02-07-0020	4	HEX. NUT ZINC 1/2-13
5	NC14-75-0020	2	FLANGE PILLOW BLOCK BEARING UCFL206-18 Ø 1 1/8"
6	NC01-04-0235	4	CARR. BOLT GR2 ZINC 1/2-13 X 1 1/2"

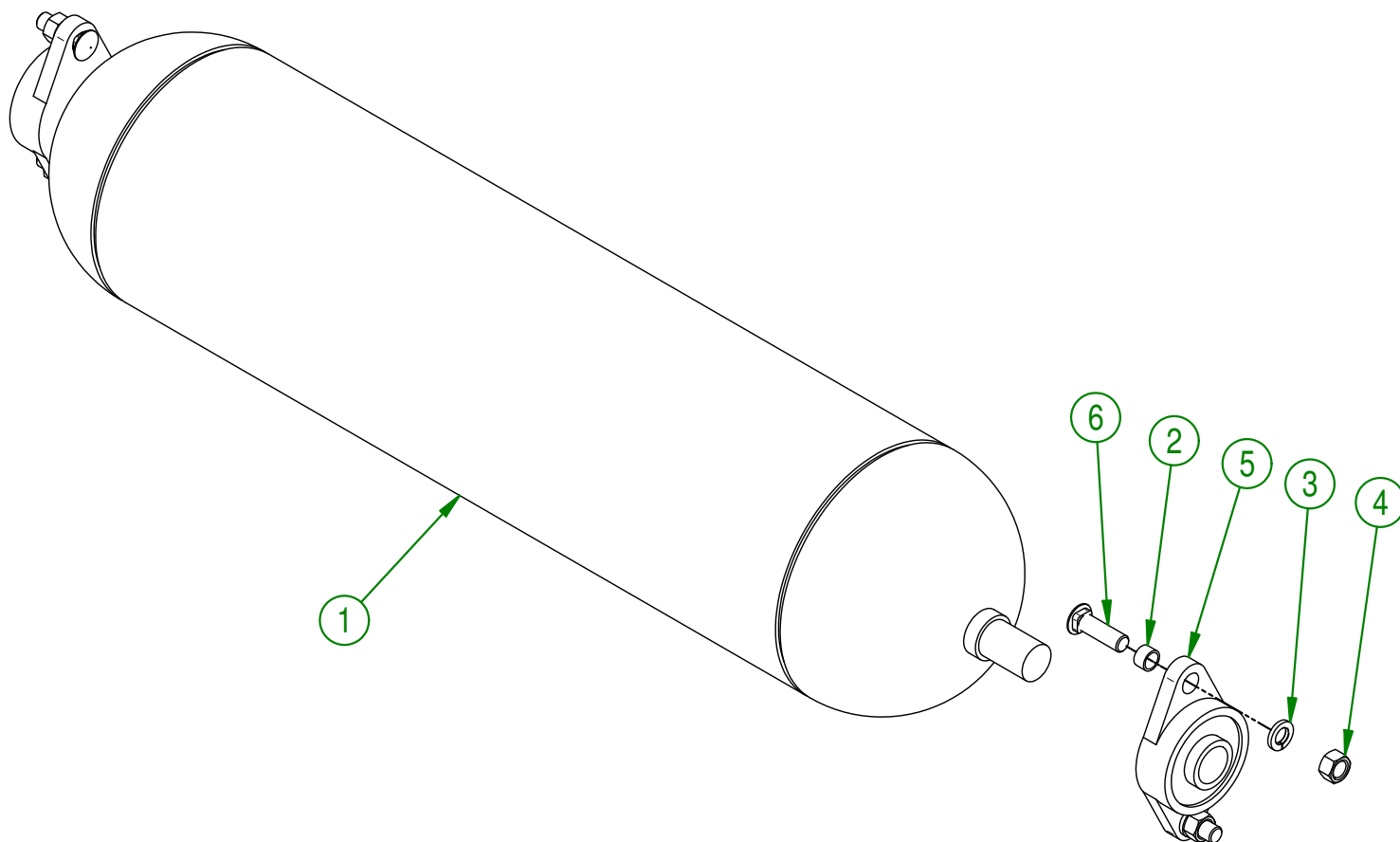

<b>AGRIMETAL</b>		
<b>ASSEMBLY LARGE TURF ROLLER</b>		
CREATION : 21-06-2016	ASSEMBLY :	32-57-3025
REVISION : 13-11-2018	AUTHOR : S.B.	Page 4 de 15

32-57-3030

#	PART #	Qty	TITLE
1	32-55-3070	1	ASSEMBLY SMALL TURF ROLLER
2	32-50-1056	1	LEFT SMALL TURF ROLLER SUPPORT
3	32-50-1061	1	RIGHT SMALL TURF ROLLER SUPPORT
4	NC01-04-0107	8	CARR. BOLT GR2 ZINC 3/8-16 X 3/4"
5	NC02-14-0019	8	FLANGE NUT HEX. NC 3/8-16 GR. B

32-55-3070

#	PART #	Qty	TITLE
6	32-11-3520	1	TURF ROLLER ONLY (REAR)
7	32-42-0105	2	REAR ROLL CAP

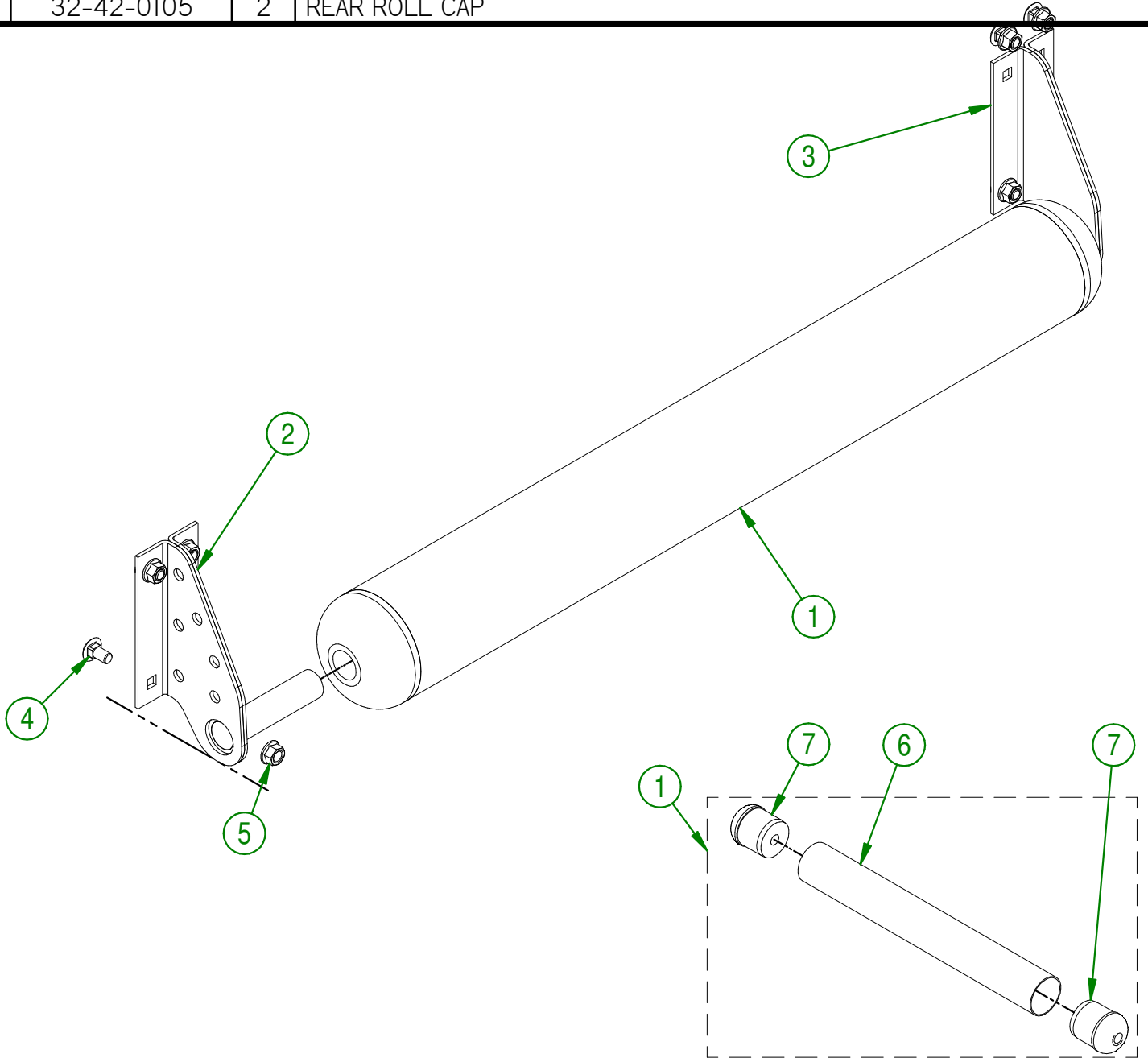

<b>AGRIMETAL</b>	
<b>ASSEMBLY SMALL TURF ROLLER</b>	
CREATION : 21-06-2016	ASSEMBLY : 32-57-3030
REVISION : 11-08-2021	AUTHOR :

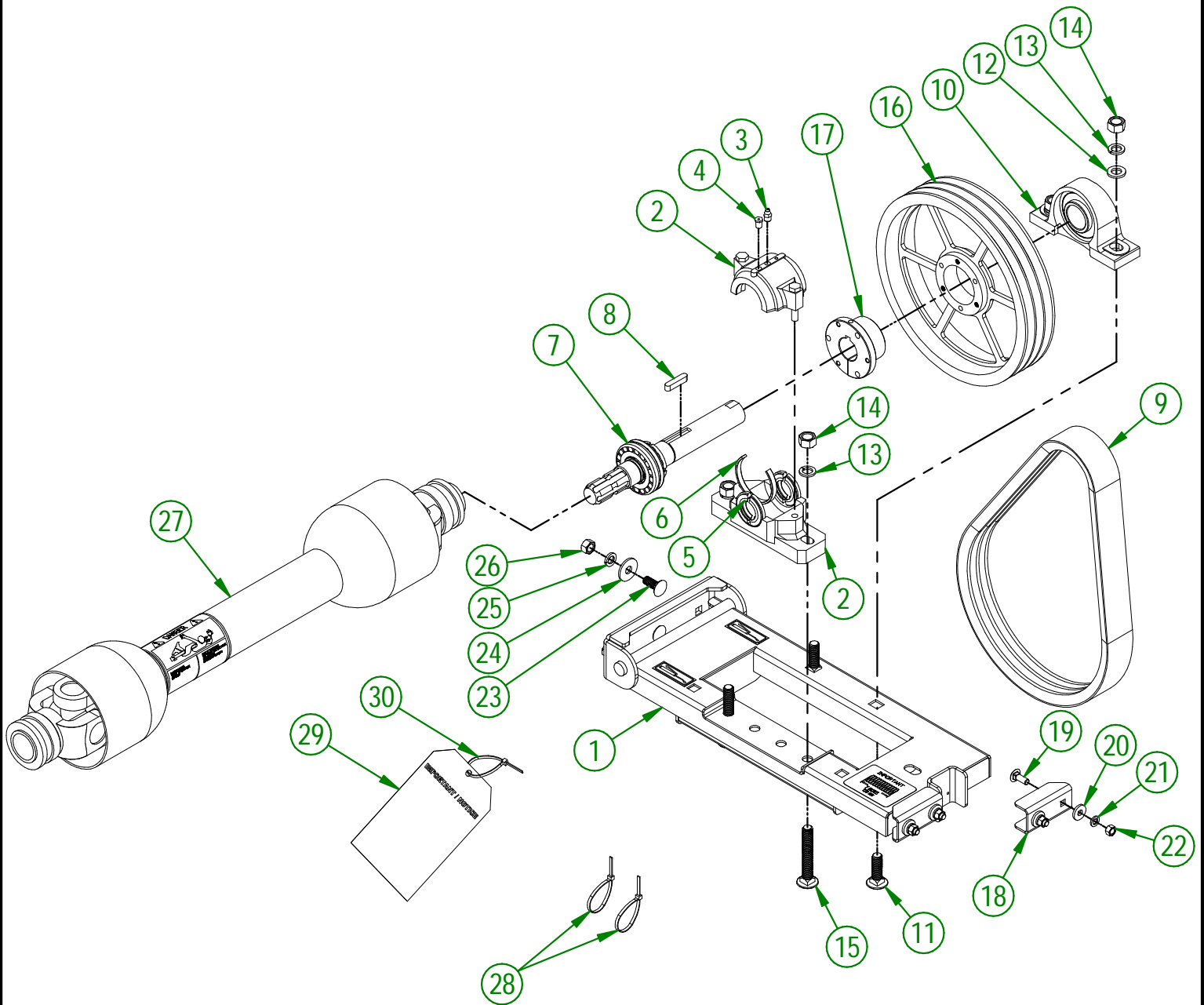

<b>AGRIMETAL</b>	
<b>BEARING BASE GROUP</b>	
CREATION : 2016-06-21	ASSEMBLY : 32-57-3035
REVISION : 2024-04-05	AUTHOR :

#	PART #	Qty	TITLE
1	32-57-3020	1	ASSEMBLY BEARING BASE
2	NC14-75-0131	1	PILLOW BLOCK CASING
3	NC01-69-0791	1	GREASE FITTING 1/8 NPT STRAIGHT
4	32-45-0000	1	BEARING PLUG
5	NC14-75-0130	1	SET JOINT 1 1/2"
6	NC14-75-0129	1	BEARING SHIM 1 1/2"
7	32-55-3063	1	ASSEMBLY DRIVE SHAFT
8	NC01-65-0100	1	KEY 3/8 X 3/8 X 1 3/4"
9	NC14-25-3377	1	TRIPLE V BELT 21/32 COGGED RAW EDGE BX-49
10	NC14-75-0035	1	PILLOW BLOCK SUPPORT UCP208-24 $\varnothing$ 1 1/2"
11	NC01-04-0268	2	BOLT CARR. GR2 ZINC 5/8-11 X 2"
12	32-01-1395	2	BEARING WHASER $\varnothing$ 3/4"
13	NC02-32-0016	4	LOCK WASHER ZINC 5/8"
14	NC02-07-0022	4	HEX. NUT ZINC 5/8-11
15	NC01-04-0276	2	BOLT CARR. GR2 ZINC 5/8-11 X 4"
16	NC14-62-0138	1	PULLEY QD 3V 1/2-5/8 X 12.75 OD X SK
17	NC14-62-0021	1	QD BUSHING SK 1 1/2"
18	32-01-1125	2	BEARING BASE STOPPER
19	NC01-04-0109	4	CARR. BOLT GR2 ZINC 3/8-16 X 1"
20	21-01-0950	4	FLAT WASHER IOGA 1.005" DIA X 25/64"
21	NC02-32-0012	4	LOCK WASHER ZINC 3/8"
22	NC02-07-0018	4	HEX. NUT ZINC 3/8-16
23	NC01-04-0234	3	CARR. BOLT GR2 ZINC 1/2-13 X 1 1/4
24	01-01-1660	3	WASHER SPACER
25	NC02-32-0014	3	LOCK WASHER ZINC 1/2"
26	NC02-07-0020	3	HEX. NUT ZINC 1/2-13
27	32-34-0040	1	PTO T40 X 36.69"
28	NC13-25-0229	2	BLACK TIE RAP
29	NC13-50-0110	1	IMPORTANT/NOTICE PTO POSTER
30	NC13-25-0245	1	BLACK TIE RAP

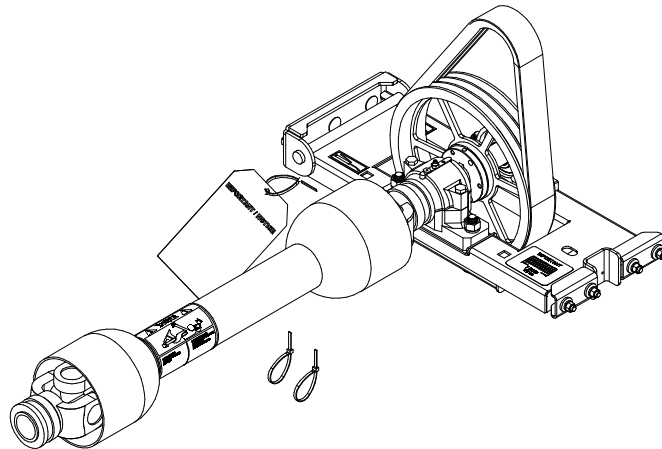

<b>AGRIMETAL</b>	
<b>BEARING BASE GROUP</b>	
CREATION : 2016-06-21	ASSEMBLY : 32-57-3035
REVISION : 2024-04-05	AUTHOR :





#	# DE PIÈCE	Qty	TITLE
1	32-50-3030	1	WELD ASSEMBLY THREADED ROD
2	NC02-22-0013	1	WASHER ZINC 5/8 ID X 1 1/2 OD
3	32-42-0135	1	SPRING GUIDE
4	12-44-0015	1	RED SPRING 1 1/2" OD 1" ID X 8 1/2"
5	32-42-0130	1	SPRING STOPPER
6	NC02-07-0022	2	HEX. NUT ZINC 5/8-11
7	32-01-3170	1	TENSIONER HANDLE

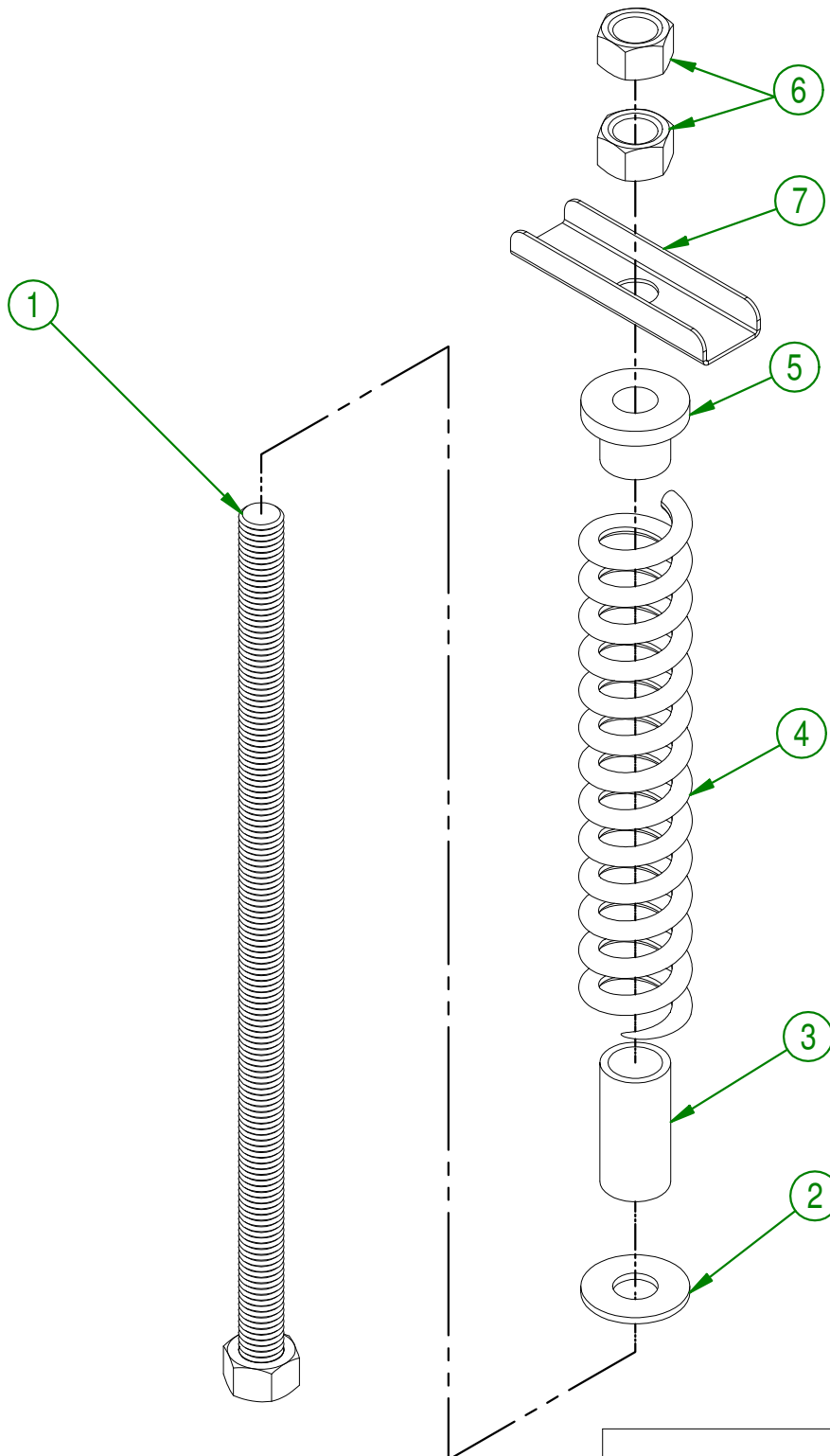

<b>AGRIMETAL</b>			
<b>ASSEMBLY TENSIONER</b>			
CREATION : 2016-06-21	ASSEMBLY :	32-57-3040	
REVISION : 2017-12-29	AUTHOR : S.B.	Page 9 de 15	

#	# DE PIÈCE	Qty	TITLE
1	32-50-3040	1	WELD ASSEMBLY BRACKET BELT COVER
2	NC01-04-0107	2	CARR. BOLT GR2 ZINC 3/8-16 X 3/4"
3	NC02-32-0012	2	LOCK WASHER ZINC 3/8"
4	NC02-07-0018	2	HEX. NUT ZINC 3/8-16

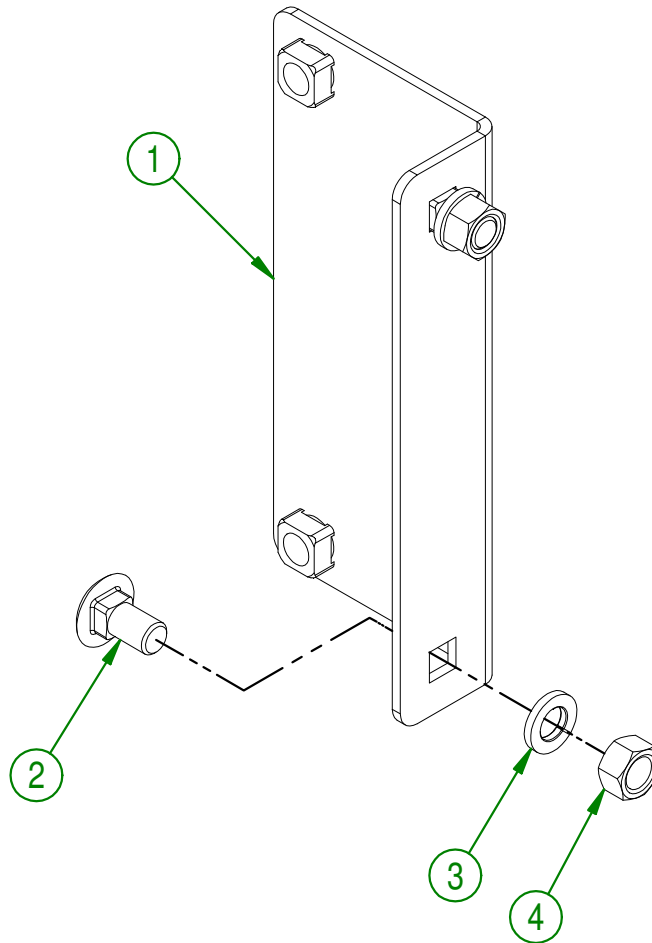

<b>AGRIMETAL</b>	
<b>ASSEMBLY BRACKET BELT COVER</b>	
CREATION : 2016-06-21	ASSEMBLY : 32-57-3055
REVISION : 2018-01-03	AUTHOR : S.B. Page 10 de 15

#	PART #	Qty	TITLE
1	NC17-94-0008	1	IMPELLER SHAFT
2	NC14-75-0025	1	FLANGE BEARING 4 HOLES UCF 208-24 X 1 1/2"
3	NC01-17-0396	4	HEX. BOLT GR2 ZINC 5/8-11 X 2"
4	NC02-32-0016	4	LOCK WASHER ZINC 5/8"
5	NC02-07-0022	4	HEX. NUT ZINC 5/8-11
6	32-09-2000	3	IMPELLER SPACER
7	NC14-75-0024	1	FLANGE BEARING 4 HOLES UCF207-20 1 1/4" DIA.
8	12-01-3051	1	REAR BEARING PROTECTOR
9	NC01-17-0250	4	HEX. BOLT GR2 ZINC 1/2-13 X 1 3/4"
10	NC02-25-0011	4	WASHER SAE ZINC 17/32 ID
11	NC02-32-0014	4	LOCK WASHER ZINC 1/2"
12	NC02-07-0020	4	HEX. NUT ZINC 1/2-13
13	32-55-3050	1	IMPELLER
14	NC01-98-0022	1	NYLON NUT HEX. 1 3/8-12 THIN
15	NC14-62-0198	1	PULLEY QD 3V 1/2-5/8 X 4.95 OD X SD (3B46)
16	NC14-62-0007	1	QD BUSHING SD 1 1/2"
17	32-41-0900	1	IMPELLER KEY
18	12-41-0915	1	PULLEY KEY

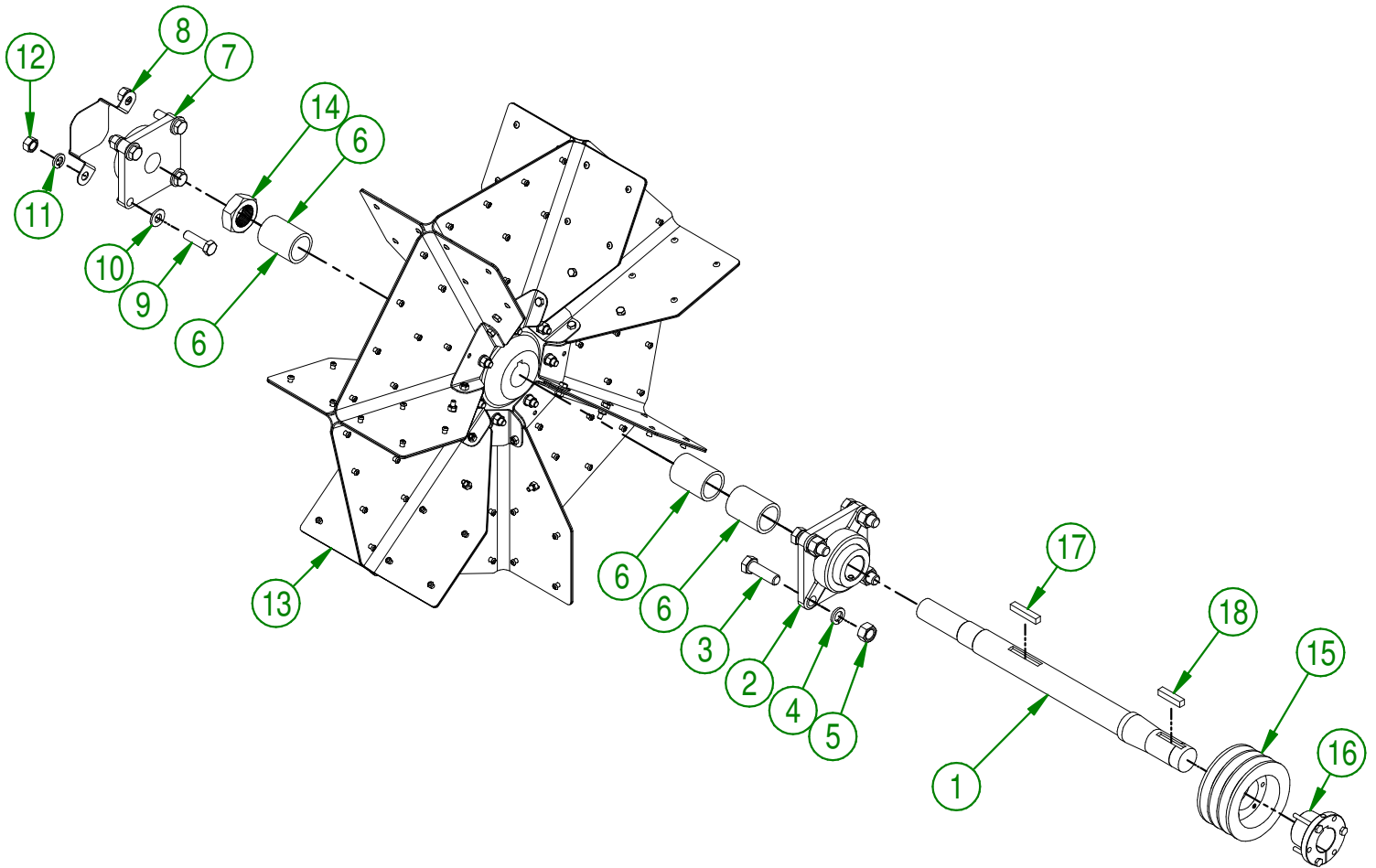

USE THESE PIECES ONLY IF YOUR SERIAL NUMBER IS AFFECTED:

#39535 AND UNDER

AGRIMETAL	
ASSEMBLY IMPELLER	
CREATION : 2016-06-21	ASSEMBLY : 32-57-3045
REVISION : 2021-02-15	AUTHOR : S.B.

32-57-6005

#	PART #	Qty	TITLE
1	NC14-75-0025	1	FLANGE BEARING 4 HOLES UCF 208-24 X 1 1/2"
2	NC01-17-0396	4	HEX. BOLT GR2 ZINC 5/8-11 X 2"
3	NC02-32-0016	4	LOCK WASHER ZINC 5/8"
4	NC02-07-0022	4	HEX. NUT ZINC 5/8-11
5	NC14-75-0024	1	FLANGE BEARING 4 HOLES UCF207-20 1 1/4" DIA.
6	12-01-3051	1	REAR BEARING PROTECTOR
7	NC01-17-0250	4	HEX. BOLT GR2 ZINC 1/2-13 X 1 3/4"
8	NC02-25-0011	4	WASHER SAE ZINC 17/32 ID
9	NC02-32-0014	4	LOCK WASHER ZINC 1/2"
10	NC02-07-0020	4	HEX. NUT ZINC 1/2-13
11	NC14-62-0198	1	PULLEY QD 3V 1/2-5/8 X 4.95 OD X SD (3B46)
12	NC14-62-0007	1	QD BUSHING SD 1 1/2"
13	12-41-0915	1	PULLEY KEY
14	32-57-6000	1	IMPELLER

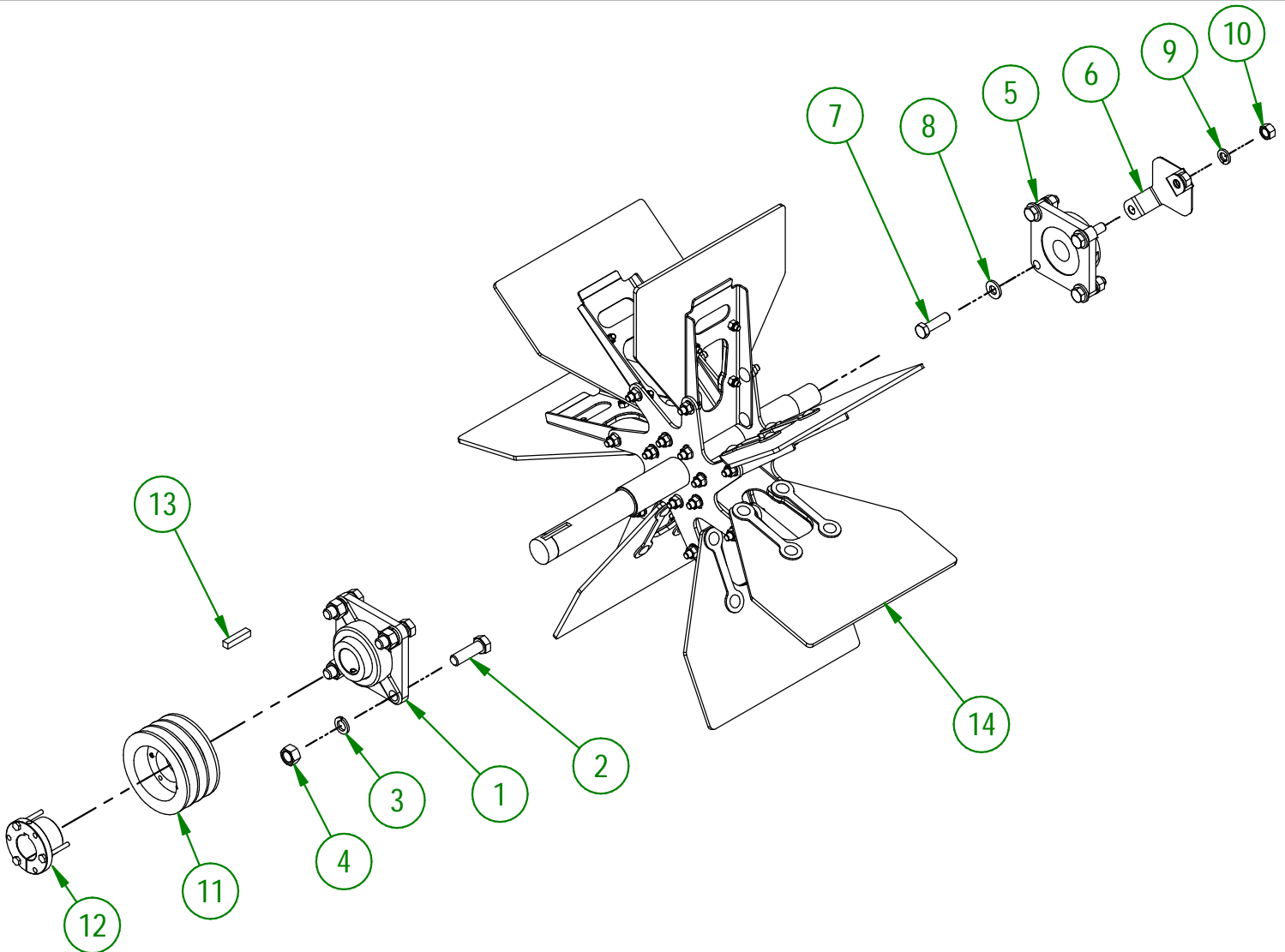

USE THESE PIECES ONLY IF YOUR SERIAL NUMBER IS AFFECTED:

BETWEEN #39536 AND #45452

**AGRIMETAL**  
**ASSEMBLY IMPELLER**

CREATION : 06/10/20  
REVISION : 26/03/24

ASSEMBLY : **32-57-6005**  
AUTHOR : J. Houle

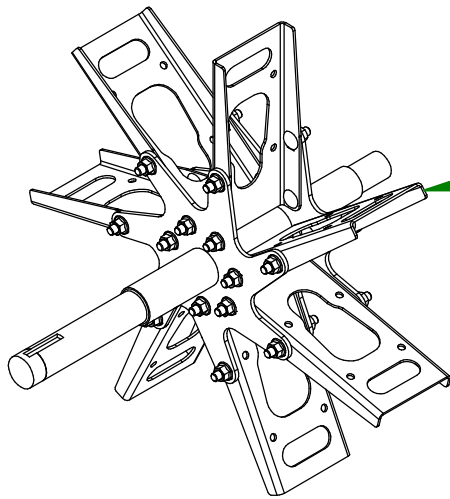

32-50-6000  
IMPELLER FRAME

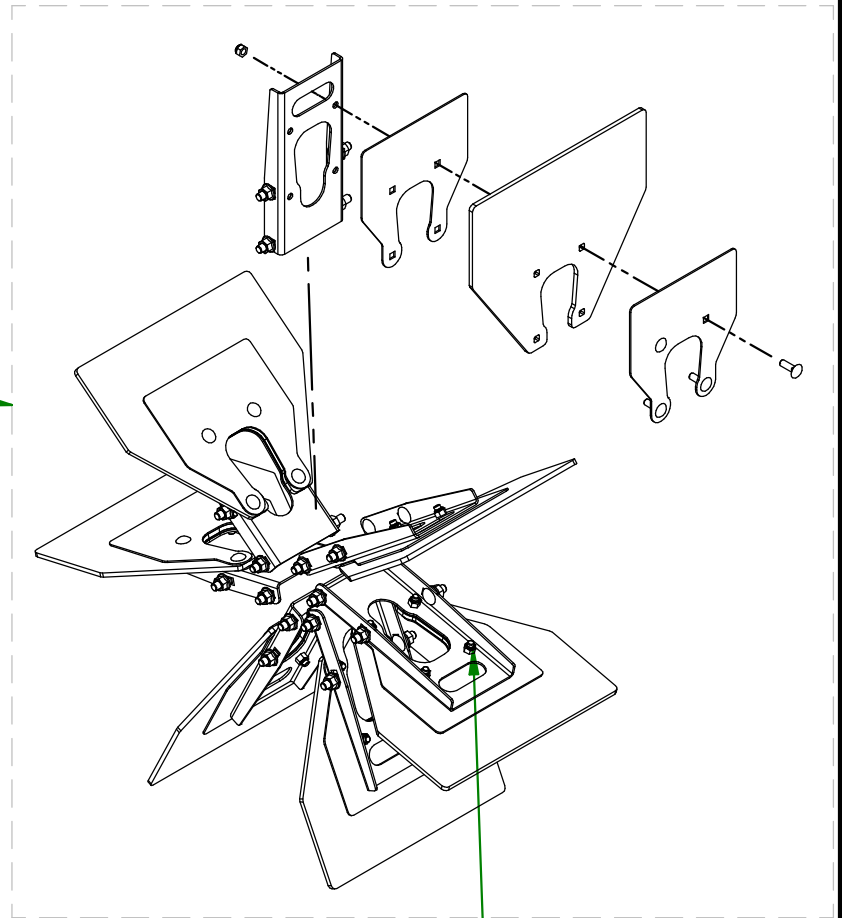

32-57-6010  
IMPELLER PADDLE AND  
PADDLE REINFORCEMENT GROUP

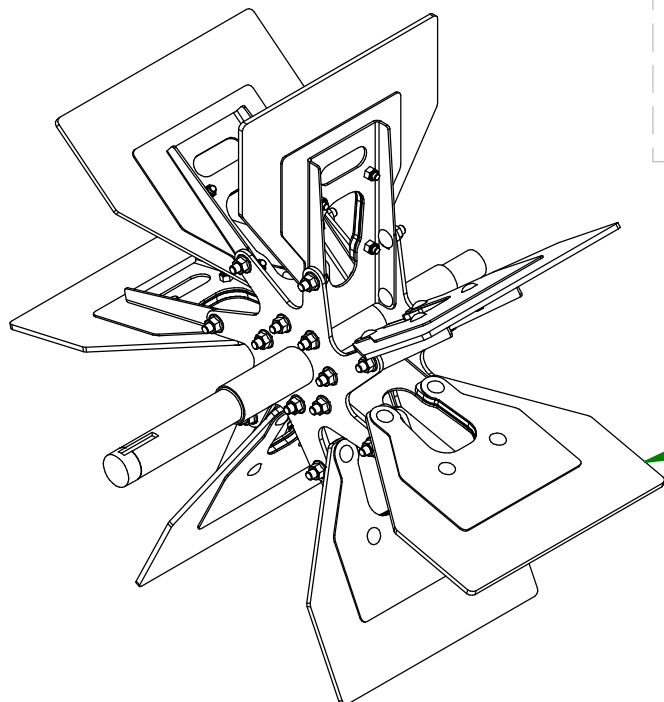

32-57-6000  
IMPELLER

TORQUE AT  
120 INCH POUNDS

USE THESE PIECES ONLY IF YOUR SERIAL  
NUMBER IS AFFECTED:

BETWEEN #39751 AND #45452

**AGRIMETAL**  
**IMPELLER**

CREATION : 06/10/20  
REVISION : 19/03/24

ASSEMBLY : **32-57-6000**  
AUTHOR : J. Houle

#	PART #	QTY	TITLE
1	NC14-75-0025	1	FLANGE BEARING 4 HOLES UCF 208-24 X 1 1/2"
2	NC01-17-0396	4	HEX. BOLT GR2 ZINC 5/8-11 X 2"
3	NC02-32-0016	4	LOCK WASHER ZINC 5/8"
4	NC02-07-0022	4	HEX. NUT ZINC 5/8-11
5	NC14-75-0024	1	FLANGE BEARING 4 HOLES UCF207-20 1 1/4" DIA.
6	12-01-3051	1	REAR BEARING PROTECTOR
7	NC01-17-0250	4	HEX. BOLT GR2 ZINC 1/2-13 X 1 3/4"
8	NC02-25-0011	4	WASHER SAE ZINC 17/32 ID
9	NC02-32-0014	4	LOCK WASHER ZINC 1/2"
10	NC02-07-0020	4	HEX. NUT ZINC 1/2-13
11	NC14-62-0198	1	PULLEY QD 3V 1/2-5/8 X 4.95 OD X SD (3B46)
12	NC14-62-0007	1	QD BUSHING SD 1 1/2"
13	12-41-0915	1	PULLEY KEY
14	32-57-6001	1	IMPELLER

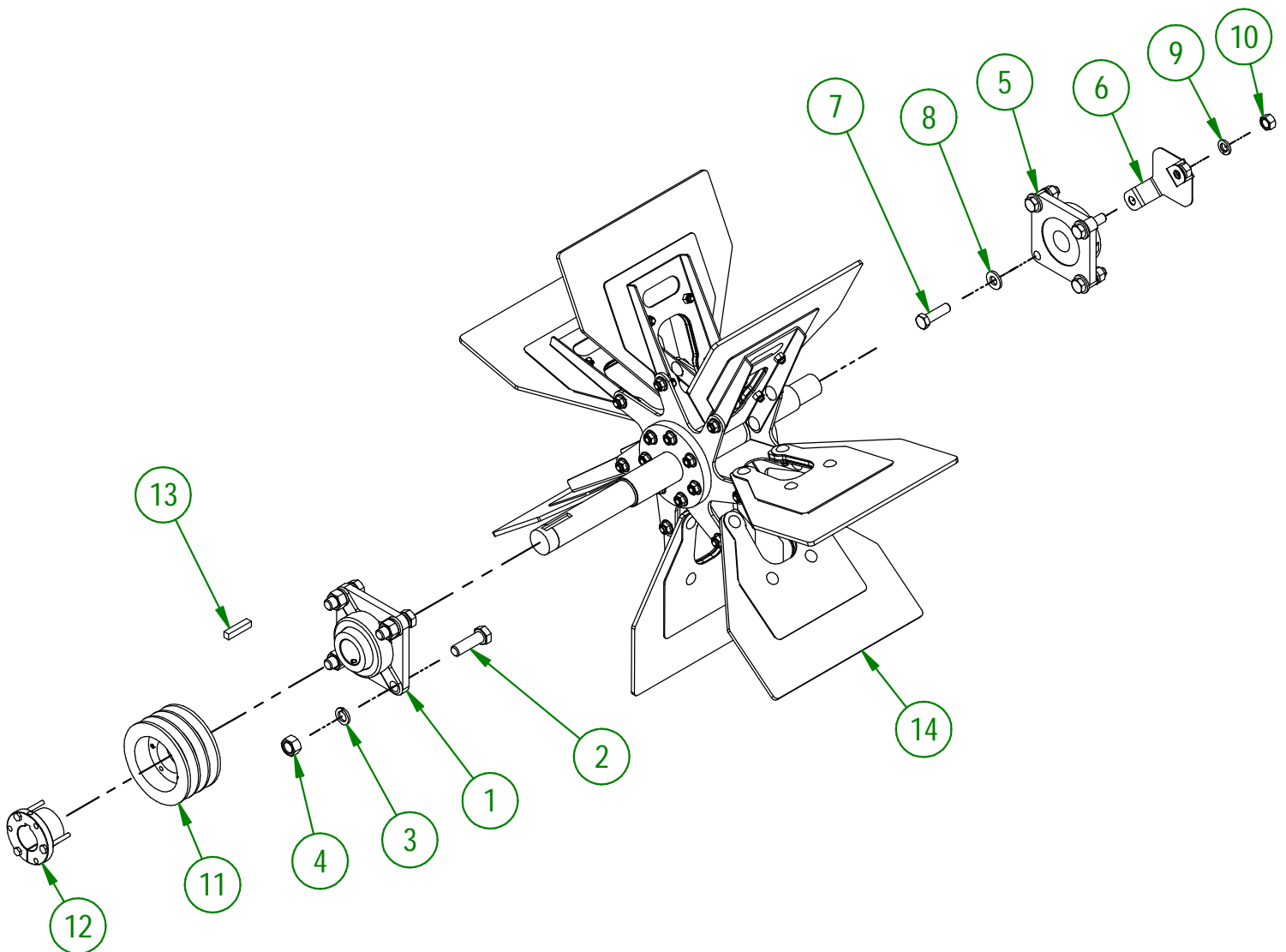

UTILISER CES PIÈCES SEULEMENT SI VOTRE NUMÉRO DE SÉRIE EST CONCERNÉ:

#45453 ET PLUS

**AGRIMETAL**  
ASSEMBLY IMPELLER

CREATION : 26/03/24  
REVISION : 26/03/24

ASSEMBLY : **32-57-6006**  
AUTHOR : J. Houle

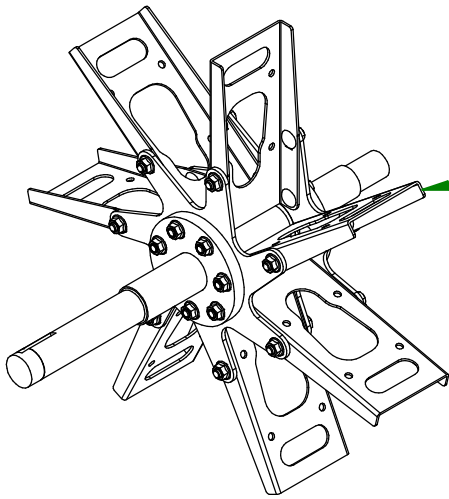

32-50-6001  
IMPELLER FRAME

32-57-6011  
IMPELLER PADDLE AND  
PADDLE REINFORCEMENT GROUP

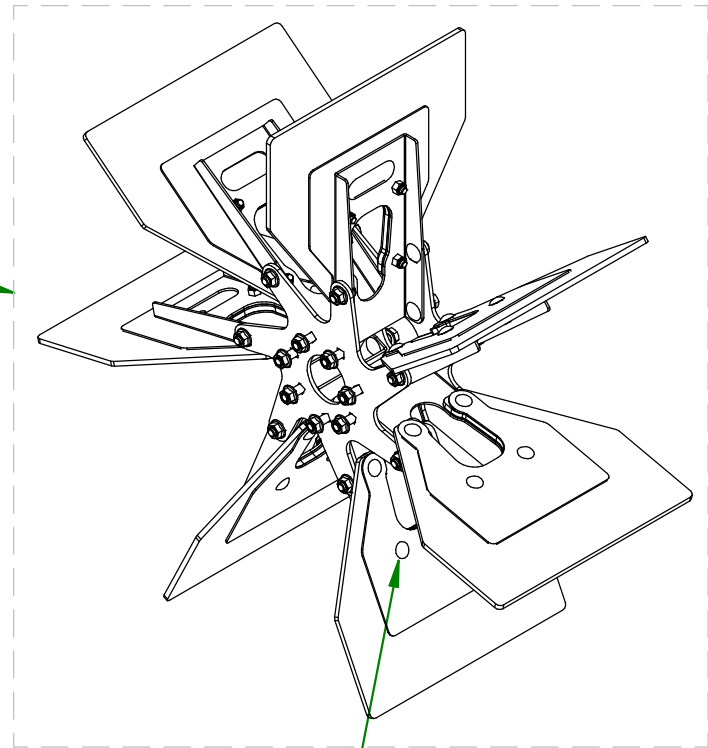

TORQUE AT  
120 INCH POUNDS

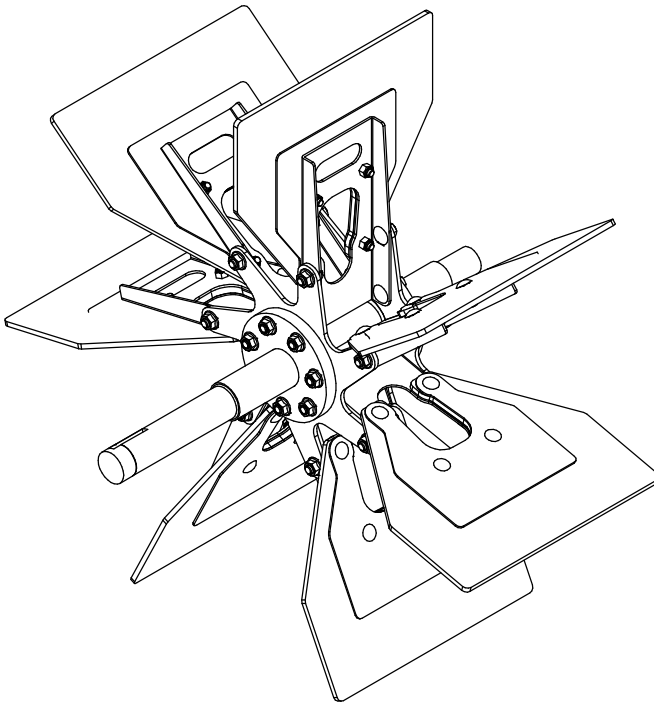

32-57-6001  
IMPELLER

USE THESE PIECES ONLY IF YOUR SERIAL  
NUMBER IS AFFECTED:

#45453 AND ABOVE

**AGRIMETAL**  
**IMPELLER**

CREATION : 19/03/24  
REVISION : 19/03/24

ASSEMBLY : **32-57-6001**  
AUTHOR : J. Houle



#	# DE PIÈCE	Qty	TITLE
1	32-57-3005	1	CASING COVER
2	NC01-04-0107	8	CARR. BOLT GR2 ZINC 3/8-16 X 3/4"
3	NC02-14-0019	10	FLANGE NUT HEX. NC 3/8-16 GR. B

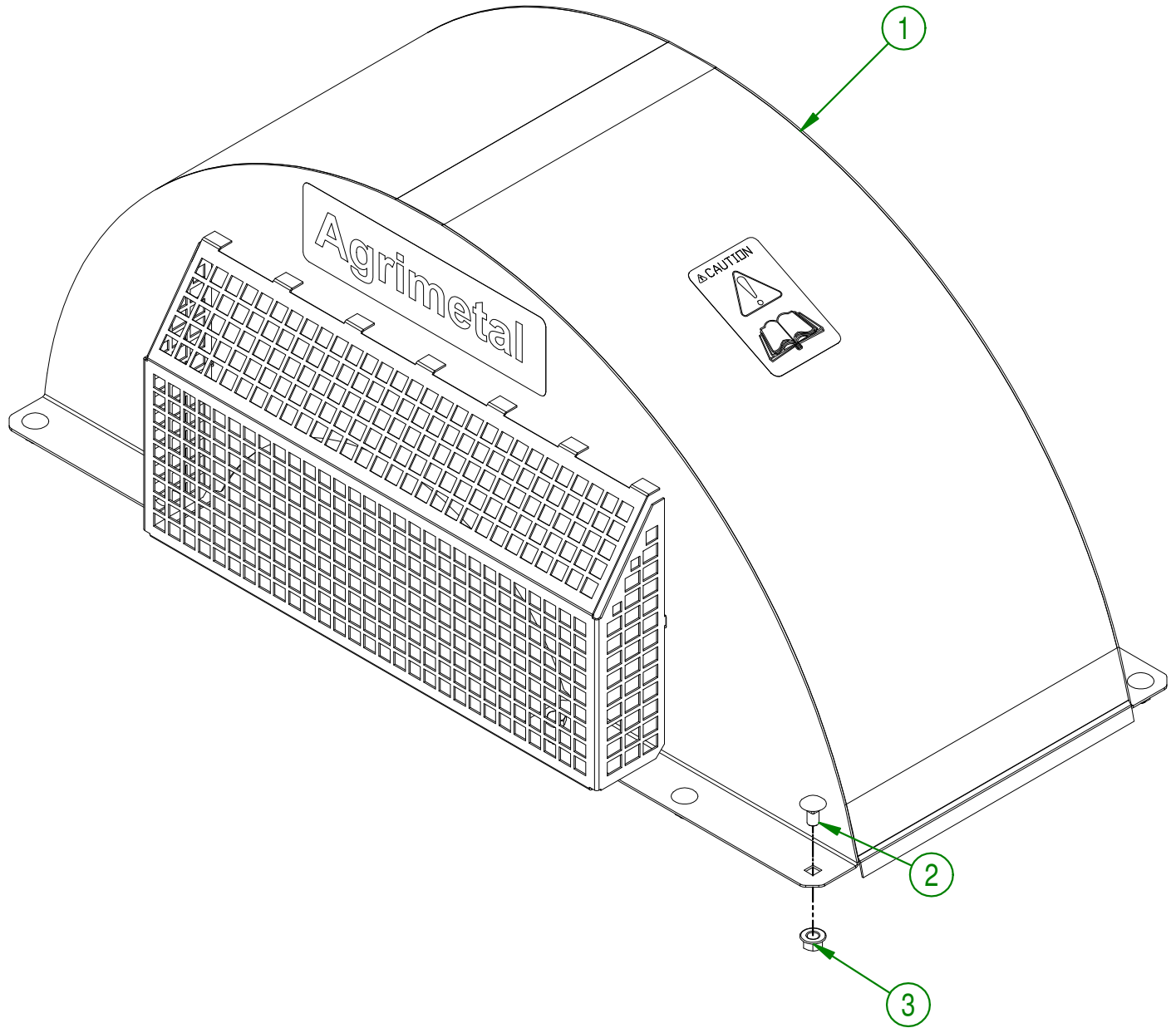

<b>AGRIMETAL</b>			
<b>ASSEMBLY CASING COVER</b>			
CREATION : 2016-06-21	ASSEMBLY :	32-57-3050	
REVISION : 2017-12-29	AUTHOR : S.B.	Page 12 de 15	

#	PART #	Qty	TITLE
1	NC01-78-0002	1	3 POINTS PIN 1/8-14 X 5 1/4"
2	09-04-0050	1	PNO 3/16" X 1 49/64" DIA. X Ø 7/8" FLAT WASHER

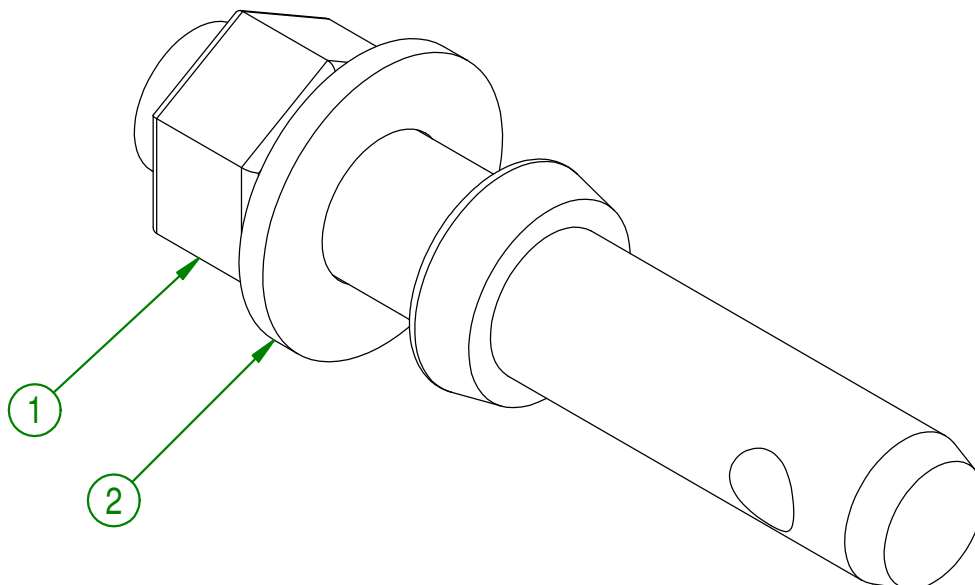

<b>AGRIMETAL</b>	
<b>ASSEMBLY 3 POINTS PIN</b>	
CREATION : 07/02/17	ASSEMBLY : <b>32-57-0095</b>
REVISION : 21/12/17	AUTHOR : F.HÉLIE   Page 13 de 15

#	PART #	Qty	TITLE
1	NC13-30-0237	1	PLASTIC TUBE FOR OPERATOR'S MANUAL
2	NC01-04-0003	3	BOLT CARR. GR2 ZINC 1/4-20 X 3/4"
3	NC02-25-0007	3	WASHER ZINC 0.281 = 9/32
4	NC01-96-0009	3	NYLON-INSERT LOCKNUT ZINC 1/4-20
5	32-98-0626	1	OPERATOR MANUAL BW 2500-3500-4500

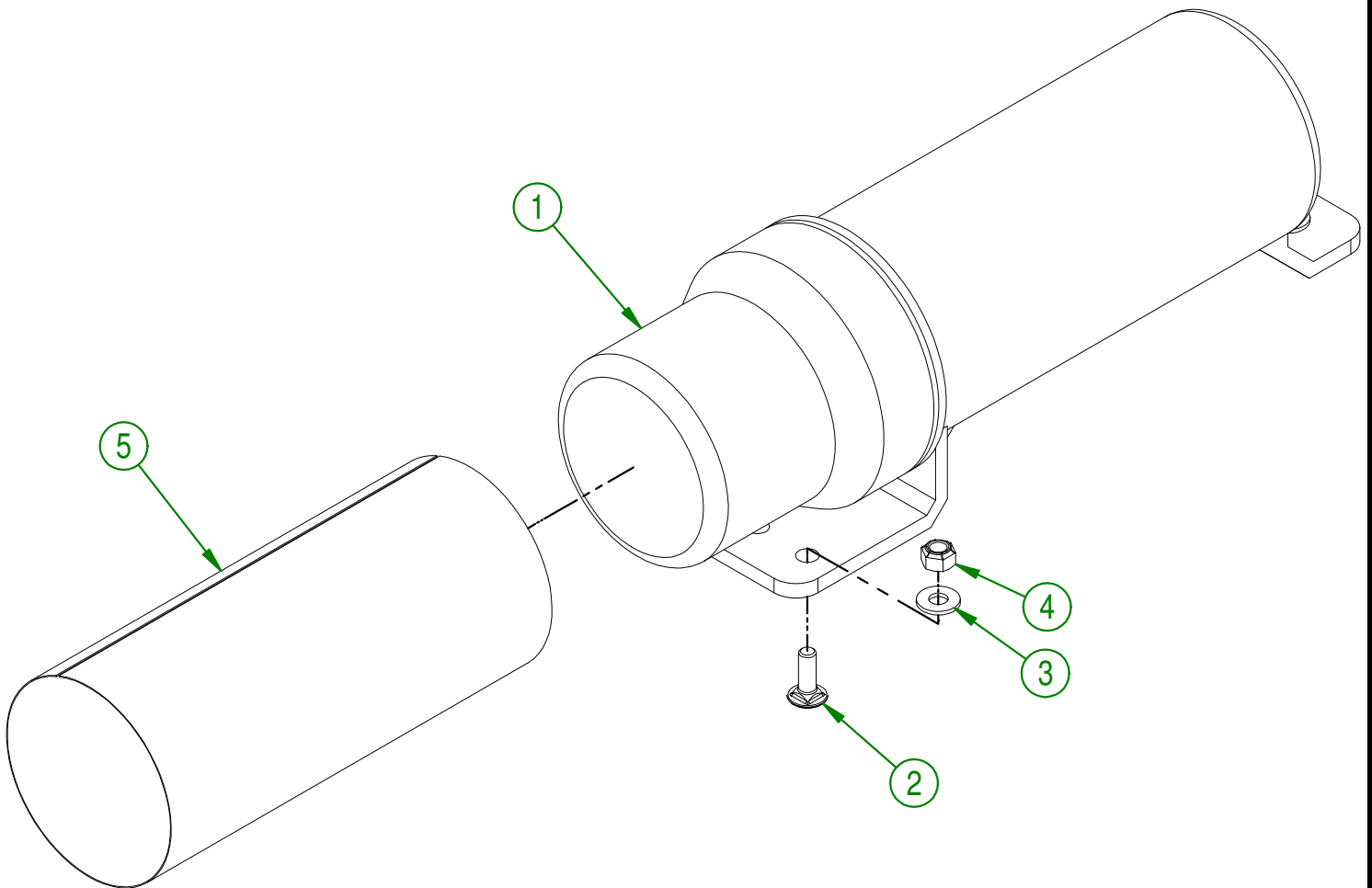

**AGRIMETAL**  
**OPERATOR MANUEL**

CREATION : 13/03/17  
 REVISION : 05/01/18

ASSEMBLY : **32-57-1105**

AUTHOR : F.HÉLIE Page 14 de 15

#	PART #	QTY	TITLE
1	NCI3-33-0158	2	STICKER 2500
2	NCI3-33-0290	1	STICKER DANGER
3	NCI3-33-0163	1	STICKER LOW DECIBEL
4	NCI3-33-0024	6	STICKER GREASE HERE
5	NCI3-33-0186	1	STICKER (DANGER)
6	NCI3-33-0192	3	STICKER (PROJECTION RISK)
7	NCI3-33-0120	1	STICKER IMPORTANT
8	NCI4-85-0276	1	STICKER (DANGER-PLASTIC GUARD)
9	NCI3-33-0035	2	STICKER AGRIMETAL
10	NCI3-33-0183	1	STICKER CAUTION OPERATION MANUAL
11	NCI3-33-0305	1	STICKER 75 dB
12	NCI3-33-0187	1	STICKER DANGER (PTO AND PERSON)
13	NCI3-33-0287	1	STICKER WARNING
14	NCI3-33-0298	2	STICKER PULL THIS WAY TO OPEN
15	NCI3-33-0005	1	STICKER MAXIMUM 540 RPM
16	NCI3-33-0179	1	STICKER IMPORTANT GREASE DRIVE LINE

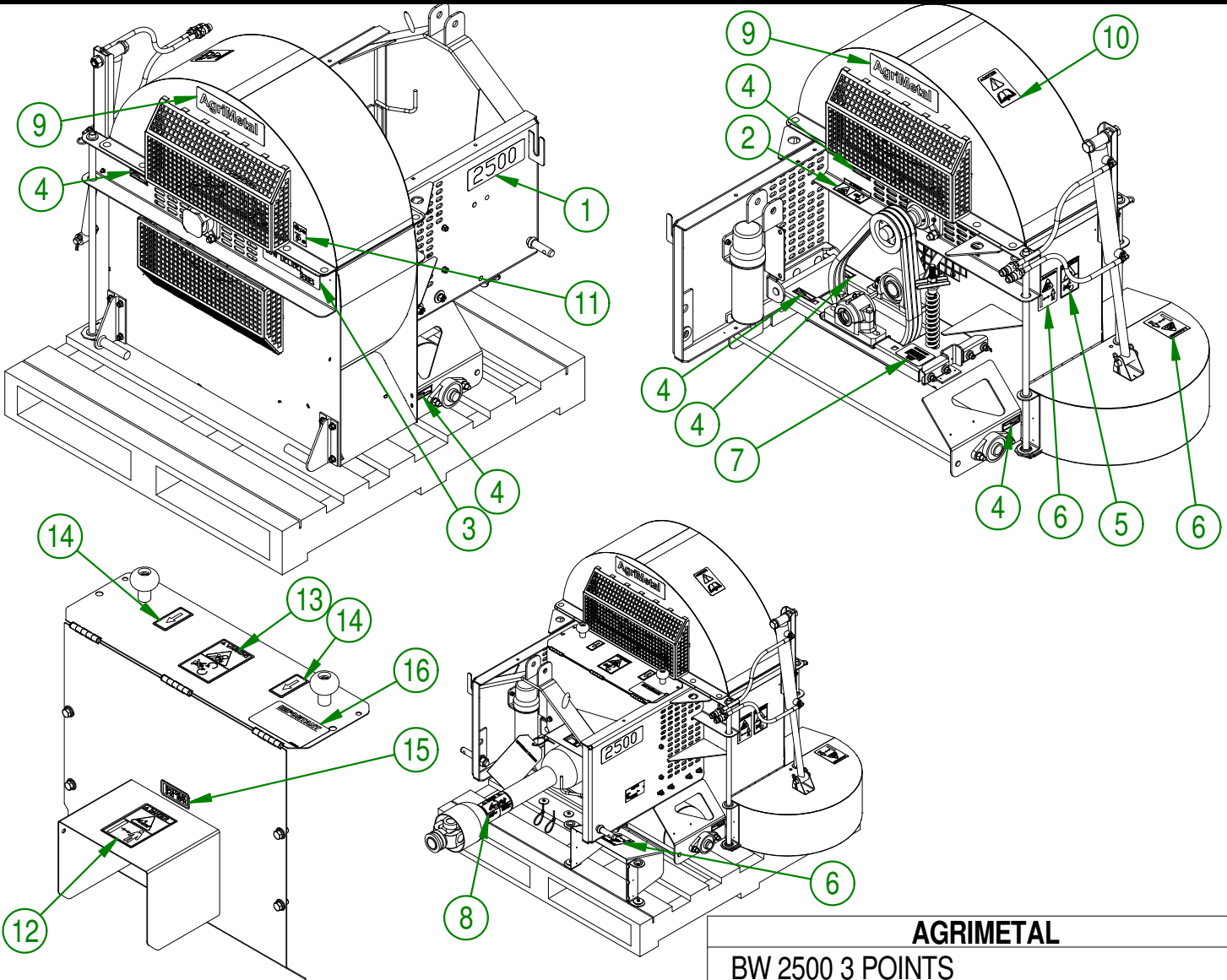

**AGRIMETAL**

**BW 2500 3 POINTS**

CREATION : 23-06-2016	ASSEMBLY :	32-99-1500
REVISION : 07-02-2019	AUTHOR :	Page 15 de 15