

# AgrMetal

## PARTS LIST

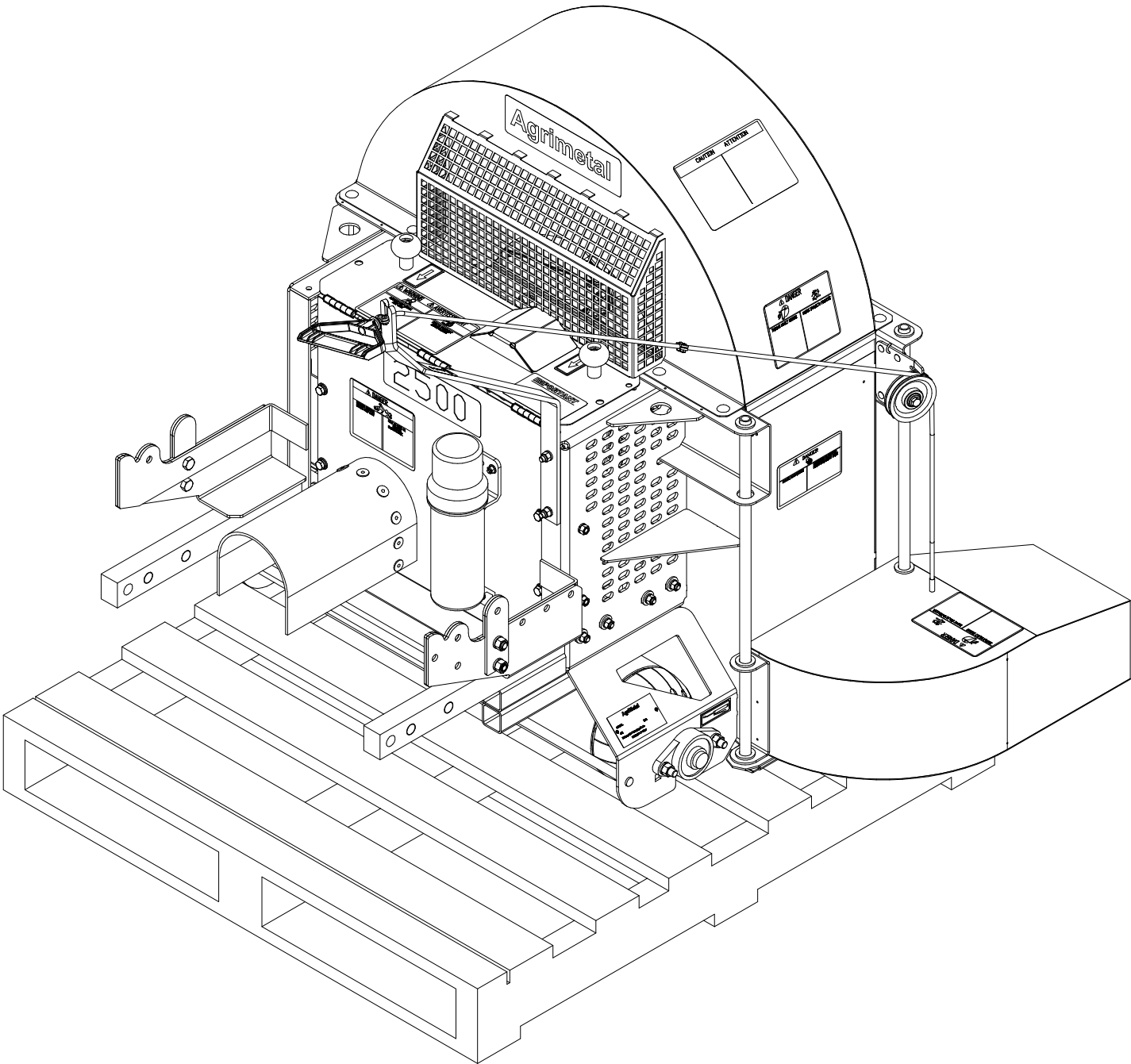

**BW 2500-F JD-1500**

32-57-3510

#	PART #	Qty	TITLE
1	NC17-46-0023	4	BUSHING 0.810" ID X 1.310" OD X 0.460"
2	25-55-0710	1	SERIAL NUMBER PLATE

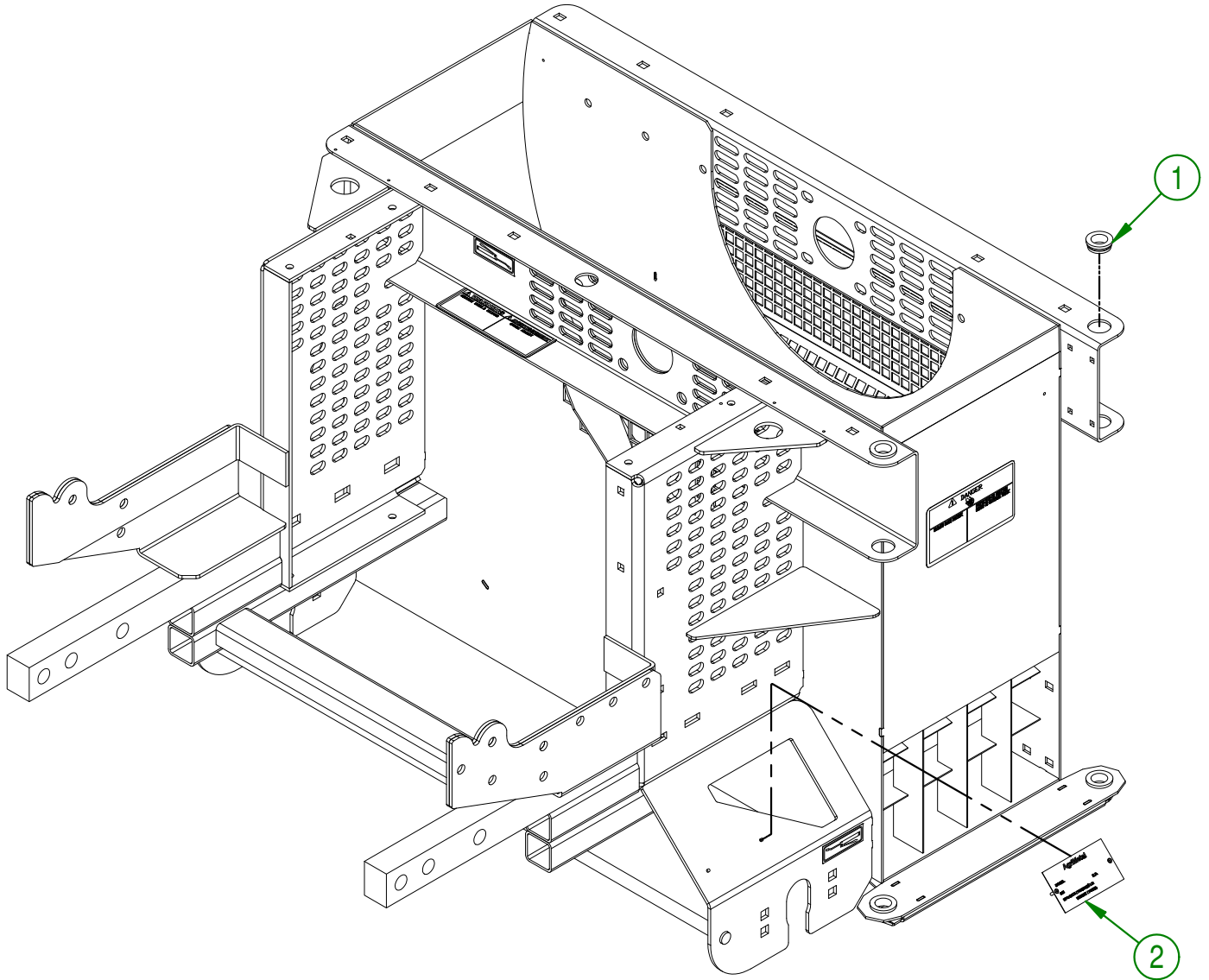

<b>AGRIMETAL</b>			
<b>ASSEMBLY CASING "STICKER INCLUDED"</b>			
CREATION : 21-06-2016	ASSEMBLY :	32-57-3510	
REVISION : 06-08-2018	AUTHOR : S.B.	Page 1 de 15	

#	PART #	Qty	TITLE
1	32-50-4565	2	LIFTING STOP EXTENSION
2	NC01-17-0248	2	HEX. BOLT GR2 ZINC 1/2-13 X 1 1/4"
3	NC01-17-0247	2	HEX. BOLT GR2 ZINC 1/2-13 X 1"
4	NC02-07-0020	4	HEX. NUT ZINC 1/2-13
5	NC02-32-0014	4	LOCK WASHER ZINC 1/2"

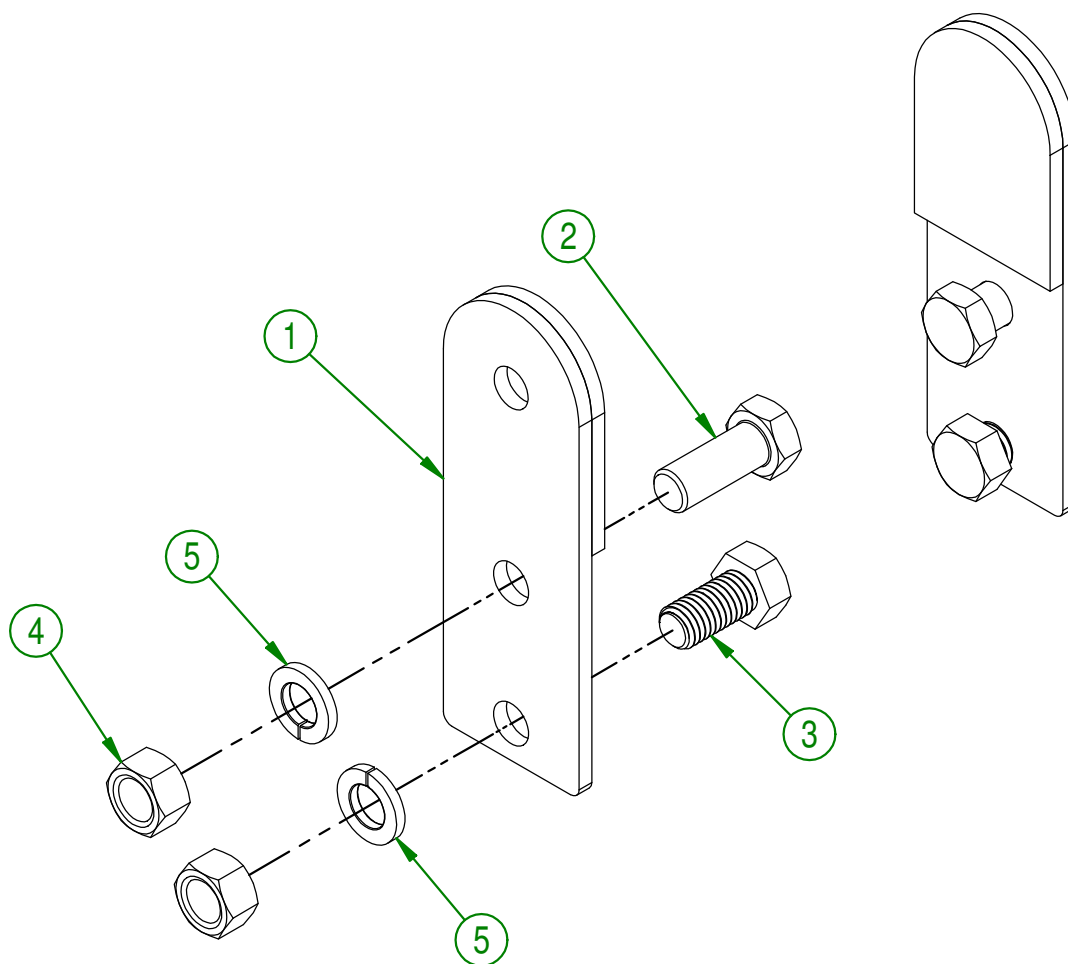

<b>AGRIMETAL</b>	
LIFTING STOP EXTENSION GROUP.	
CREATION : 29/03/18	ASSEMBLY : <b>32-57-4265</b>
REVISION : 12/04/18	AUTHOR : F.HÉLIE   Page 2 de 15

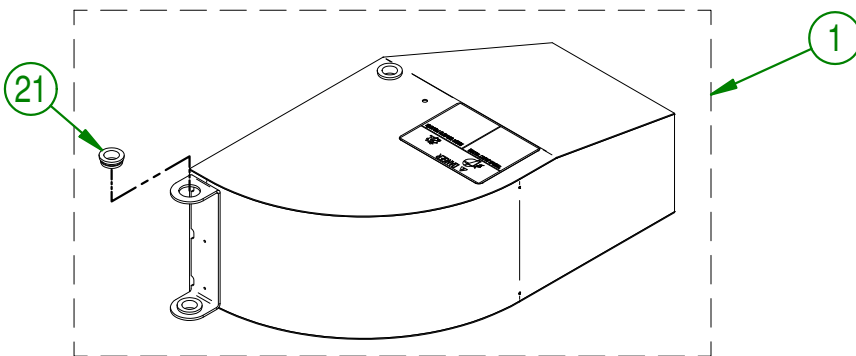
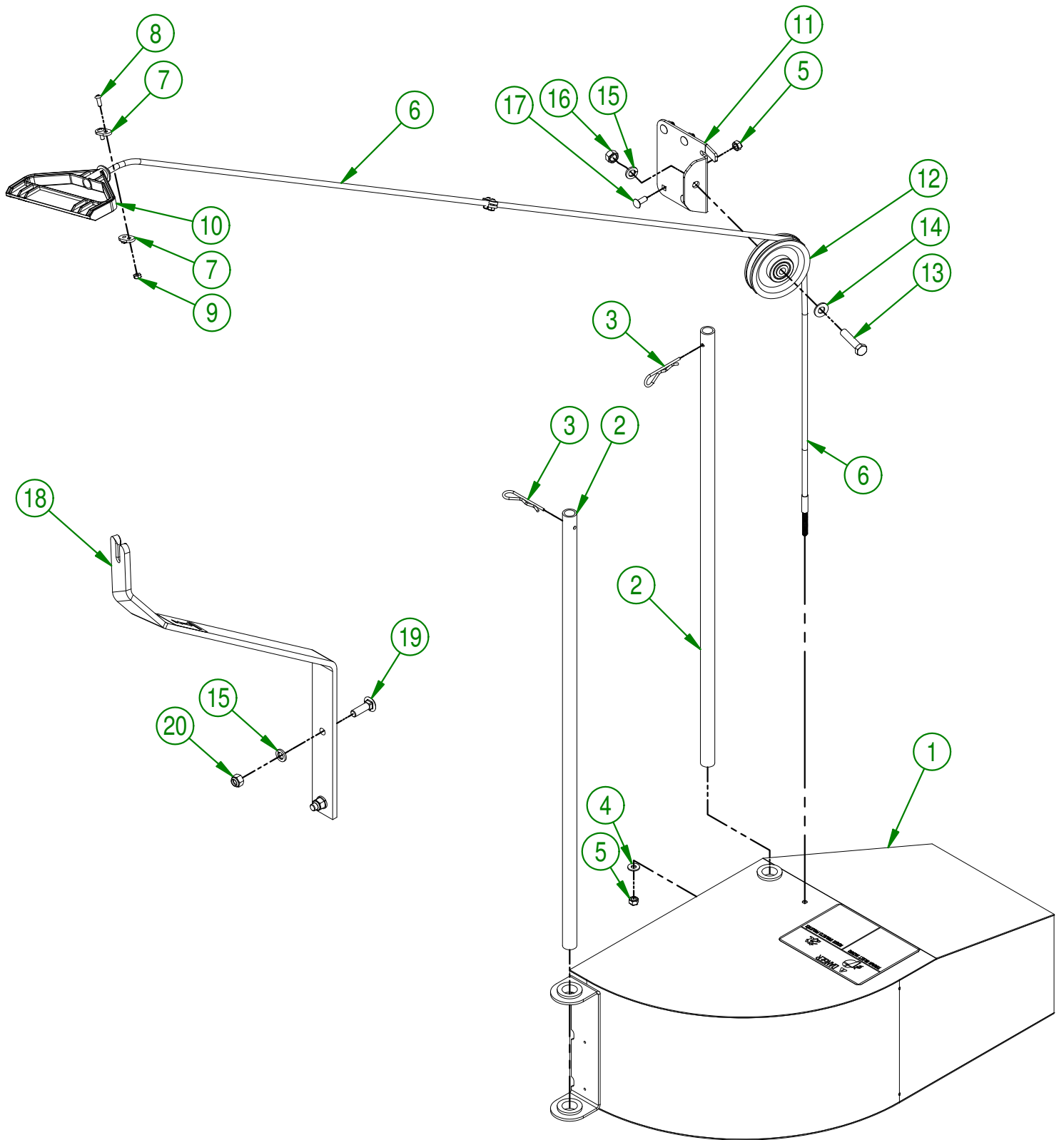

<b>AGRIMETAL</b>		
<b>ASSEMBLY DEFLECTOR</b>		
CREATION : 22-06-2016	ASSEMBLY :	32-57-3590
REVISION : 06-03-2019	AUTHOR :	Page 3 de 15

## 32-57-3590

#	PART #	Qty	TITLE
1	32-55-3575	1	ASSEMBLY DEFLECTOR
2	32-11-2505	2	DEFLECTOR GUIDE
3	NC01-63-0015	2	COTTER PIN Z 1/8" X 2 5/8"
4	NC02-25-0007	1	WASHER ZINC 0.281 = 9/32
5	NC01-96-0009	5	NYLON-INSERT LOCKNUT ZINC 1/4-20
6	NC17-02-0140	1	ASSEMBLY DEFLECTOR CABLE BW 2500-F 71 1/4"
7	32-22-5600	4	BRACKET FOR CABLE
8	NC02-40-0082	4	MACHINE SCREW PHILLIPS ZINC 10-24 OU 3/16"
9	NC01-96-0006	4	NYLON NUT ZINC 10-24
10	NC13-80-0065	1	STARTER HANDLE
11	32-01-0945	1	PULLEY SUPPORT
12	NC14-63-0001	1	PULLEY PLASTIC 3 1/2" OD X BEARING 3/8"
13	NC01-17-0117	1	HEX. BOLT GR2 ZINC 3/8-16 X 1 3/4"
14	01-01-2485	1	FLAT WASHER 14 GA X 13/16"OD X 25/64" ID
15	NC02-32-0012	3	LOCK WASHER ZINC 3/8"
16	NC02-07-0018	1	HEX. NUT ZINC 3/8-16
17	NC01-04-0002	4	CARR. BOLT GR2 ZINC 1/4-20 X 5/8"
18	32-57-3500	1	ASSEMBLY CABLE SUPPORT
19	NC01-04-0110	2	CARR. BOLT GR2 ZINC 3/8-16 X 1 1/4"
20	NC01-96-0011	2	NYLON NUT 3/8-16

## 32-55-3575

#	PART #	Qty	TITLE
21	NC17-46-0023	4	BUSHING 0.810" ID X 1.310" OD X 0.460"

**AGRIMETAL****ASSEMBLY DEFLECTOR**

CREATION : 22-06-2016

ASSEMBLY :

**32-57-3590**

REVISION : 06-03-2019

AUTHOR :

Page 4 de 15

#	PART #	Qty	TITLE
1	32-46-0000	1	FRONT ROLLER
2	NC13-80-0061	4	PAD STEEL POUDEUR 1/2" X 5/8" X 3/8"
3	NC02-32-0014	4	LOCK WASHER ZINC 1/2"
4	NC02-07-0020	4	HEX. NUT ZINC 1/2-13
5	NC14-75-0020	2	FLANGE PILLOW BLOCK BEARING UCFL206-18 Ø 1 1/8"
6	NC01-04-0235	4	CARR. BOLT GR2 ZINC 1/2-13 X 1 1/2"

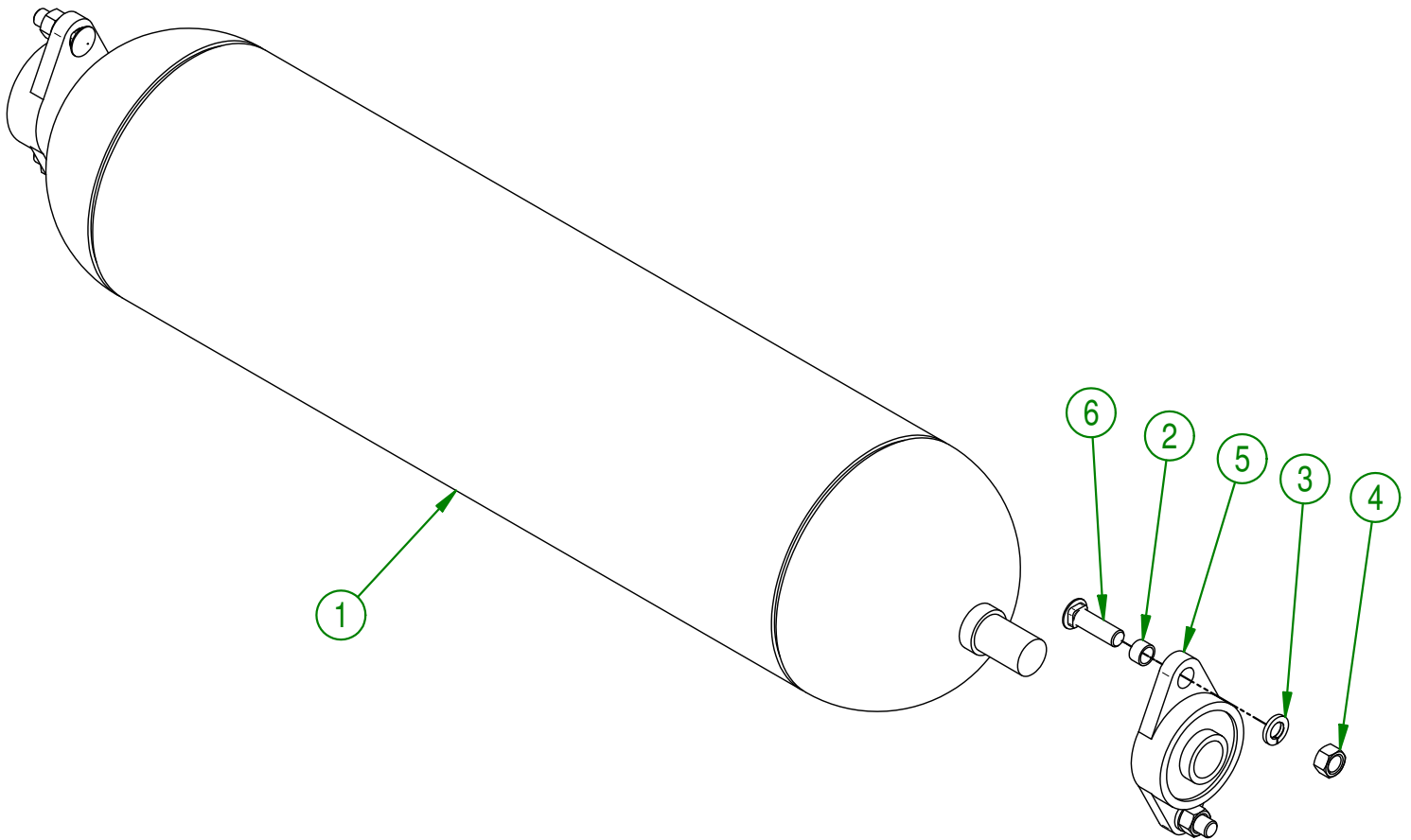

<b>AGRIMETAL</b>		
<b>ASSEMBLY LARGE TURF ROLLER</b>		
CREATION : 21-06-2016	ASSEMBLY :	32-57-3025
REVISION : 13-11-2018	AUTHOR : S.B.	Page 5 de 15

32-57-3030

#	PART #	Qty	TITLE
1	32-55-3070	1	ASSEMBLY SMALL TURF ROLLER
2	32-50-1056	1	LEFT SMALL TURF ROLLER SUPPORT
3	32-50-1061	1	RIGHT SMALL TURF ROLLER SUPPORT
4	NC01-04-0107	8	CARR. BOLT GR2 ZINC 3/8-16 X 3/4"
5	NC02-14-0019	8	FLANGE NUT HEX. NC 3/8-16 GR. B

32-55-3070

#	PART #	Qty	TITLE
6	32-11-3520	1	TURF ROLLER ONLY (REAR)
7	32-42-0105	2	REAR ROLL CAP

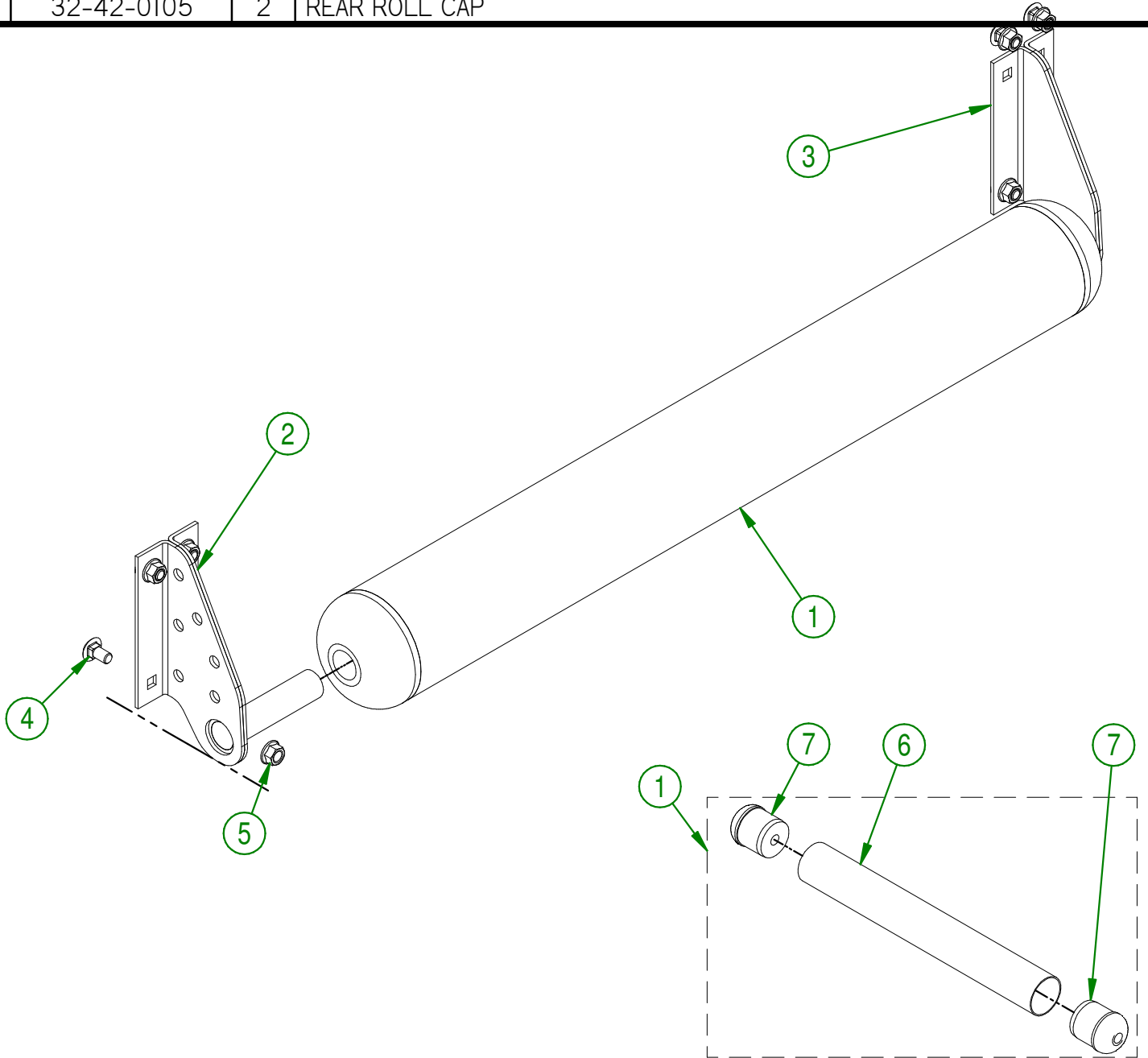

<b>AGRIMETAL</b>	
<b>ASSEMBLY SMALL TURF ROLLER</b>	
CREATION : 21-06-2016	ASSEMBLY : 32-57-3030
REVISION : 11-08-2021	AUTHOR :

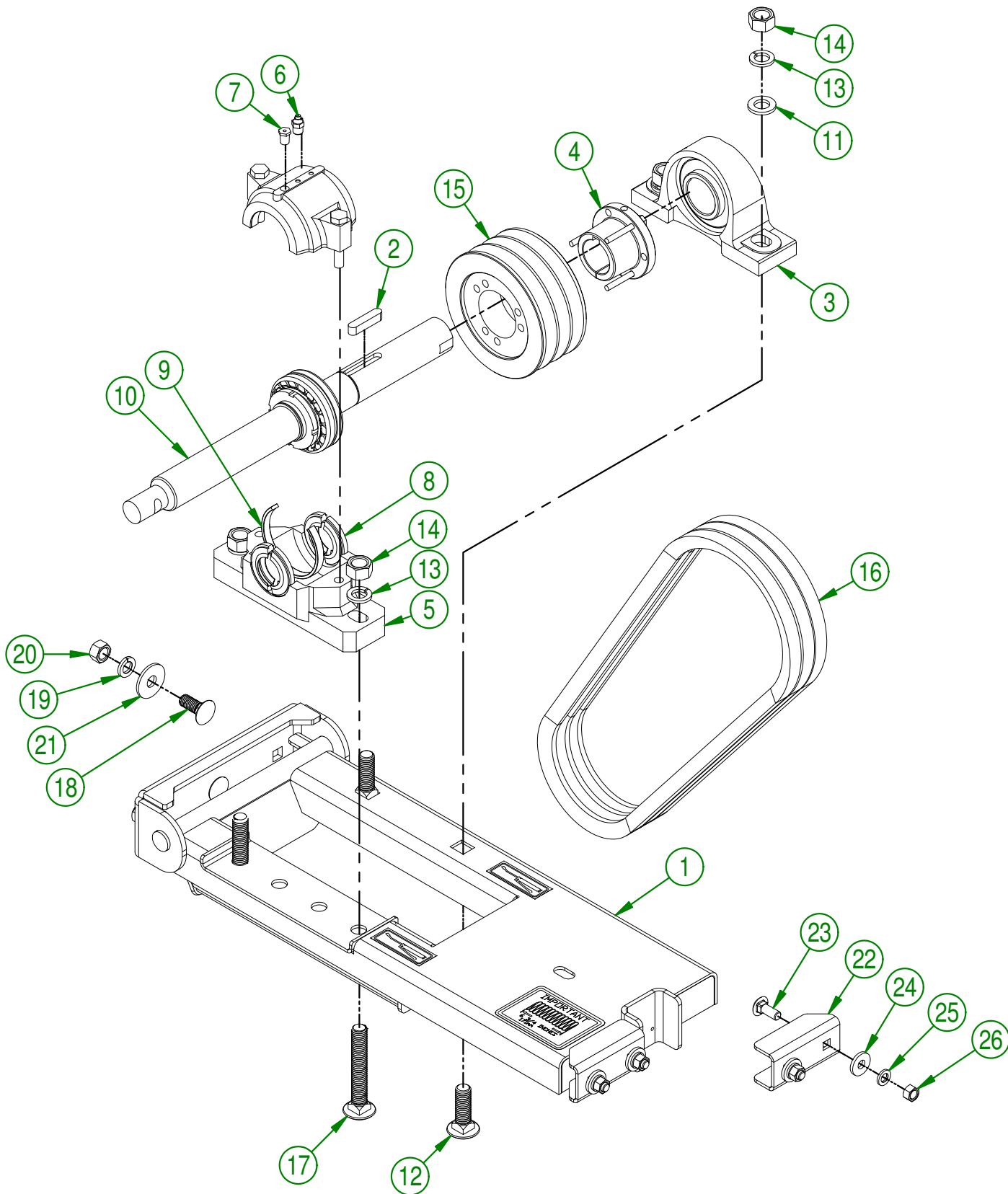

<b>AGRIMETAL</b>			
<b>BEARING BASE GROUP</b>			
CREATION : 21-06-2016	ASSEMBLY :	32-57-3535	
REVISION : 09-04-2019	AUTHOR : S.B.	Page 7 de 15	



#	PART #	Qty	TITLE
1	32-57-3520	1	ASSEMBLY BEARING BASE "STICKER INCLUDED"
2	NC01-65-0100	1	KEY 3/8 X 3/8 X 1 3/4"
3	NC14-75-0035	1	PILLOW BLOCK SUPPORT UCP208-24 Ø 1 1/2"
4	NC14-62-0007	1	QD BUSHING SD 1 1/2"
5	NC14-75-0131	1	PILLOW BLOCK CASING
6	NC01-69-0791	1	GREASE FITTING 1/8 NPT STRAIGHT
7	32-45-0000	1	BEARING PLUG
8	NC14-75-0130	1	SET JOINT 1 1/2"
9	NC14-75-0129	1	BEARING SHIM 1 1/2"
10	32-55-3563	1	ASSEMBLY DRIVE SHAFT
11	32-01-1395	2	BEARING WHASER Ø 3/4"
12	NC01-04-0268	2	BOLT CARR. GR2 ZINC 5/8-11 X 2"
13	NC02-32-0016	4	LOCK WASHER ZINC 5/8"
14	NC02-07-0022	4	HEX. NUT ZINC 5/8-11
15	NC14-62-0201	1	PULLEY QD 3V 1/2-5/8 X 5.55 OD X SD 3B52
16	NC14-25-1083	3	V BELT 21/32 COGGED RAW EDGE BX-44
17	NC01-04-0276	2	BOLT CARR. GR2 ZINC 5/8-11 X 4"
18	NC01-04-0234	3	CARR. BOLT GR2 ZINC 1/2-13 X 1 1/4
19	NC02-32-0014	3	LOCK WASHER ZINC 1/2"
20	NC02-07-0020	3	HEX. NUT ZINC 1/2-13
21	01-01-1660	3	WASHER SPACER
22	32-01-1125	2	BEARING BASE STOPPER
23	NC01-04-0109	4	CARR. BOLT GR2 ZINC 3/8-16 X 1"
24	21-01-0950	4	FLAT WASHER IOGA 1.005" DIA X 25/64"
25	NC02-32-0012	4	LOCK WASHER ZINC 3/8"
26	NC02-07-0018	4	HEX. NUT ZINC 3/8-16

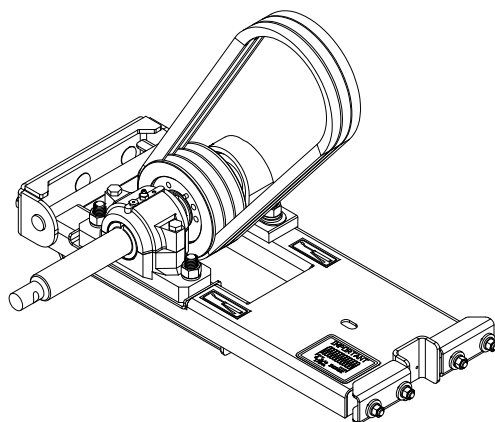

<b>AGRIMETAL</b>		
<b>BEARING BASE GROUP</b>		
CREATION : 21-06-2016	ASSEMBLY :	<b>32-57-3535</b>
REVISION : 09-04-2019	AUTHOR : S.B.	Page 8 de 15

#	PART #	Qty	TITLE
1	NC17-46-0018	2	HANDLE KNOB
2	NC01-17-0119	2	HEX. BOLT GR2 ZINC 3/8-16 X 2 1/4"
3	01-01-2485	6	FLAT WASHER
4	NC02-32-0012	6	LOCK WASHER ZINC 3/8"
5	NC02-07-0018	2	HEX. NUT ZINC 3/8-16
6	NC13-15-0080	1	BLACK RUBBER SN60 3/16" X 12" X 15 7/8"
7	16-01-2720	9	WASHER 13/16" DIA. X 13/64"
8	NC01-78-0016	9	ALUMINIUM BLIND POP RIVET STEEL MANDREL 0.187 X 0.690
9	32-57-4120	1	ASSEMBLY BELT COVER
10	NC01-17-0112	4	HEX. BOLT GR2 ZINC 3/8-16 X 3/4"
11	NC01-04-0055	2	CARR. BOLT GR2 ZINC 5/16-18 X 5/8"
12	NC01-96-0010	2	NYLON NUT HEX. ZINC 5/16-18

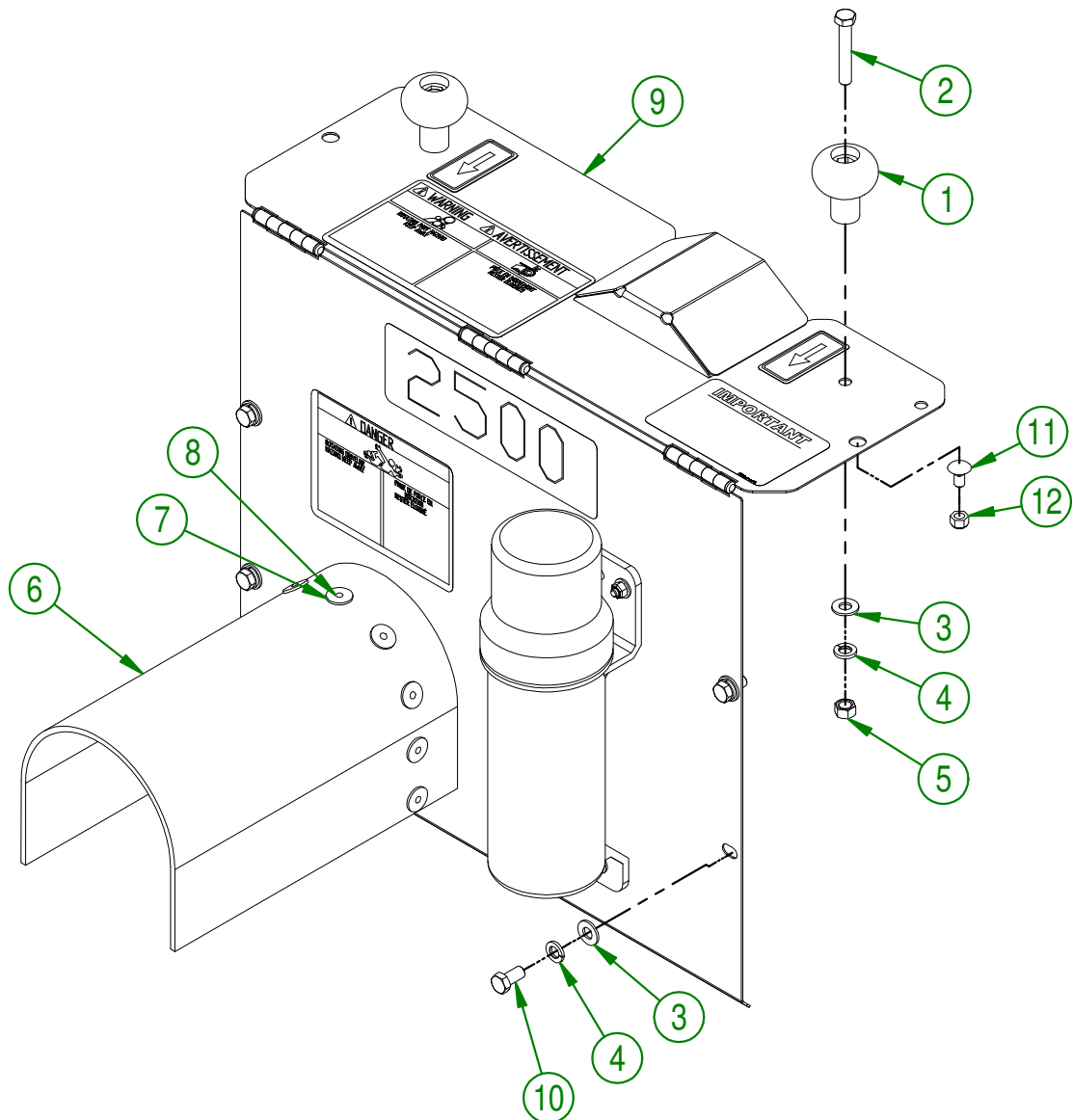
**AGRIMETAL****ASSEMBLY BELT COVER**

CREATION : 2016-06-21

ASSEMBLY :

32-57-3585

REVISION : 2018-03-06

AUTHOR : S.B.

Page 9 de 15

#	PART #	Qty	TITLE
1	32-50-3530	1	WELD ASSEMBLY THREADED ROD
2	NC02-25-0011	1	WASHER SAE ZINC 17/32 ID
3	32-42-0115	1	SPRING GUIDE
4	NC13-86-0083	1	BLUE SPRING 1/2" ID X 1" OD X 4"
5	32-42-0140	1	SPRING STOPPER
6	NC02-07-0020	2	HEX. NUT ZINC 1/2-13
7	32-01-3075	1	HANDLE

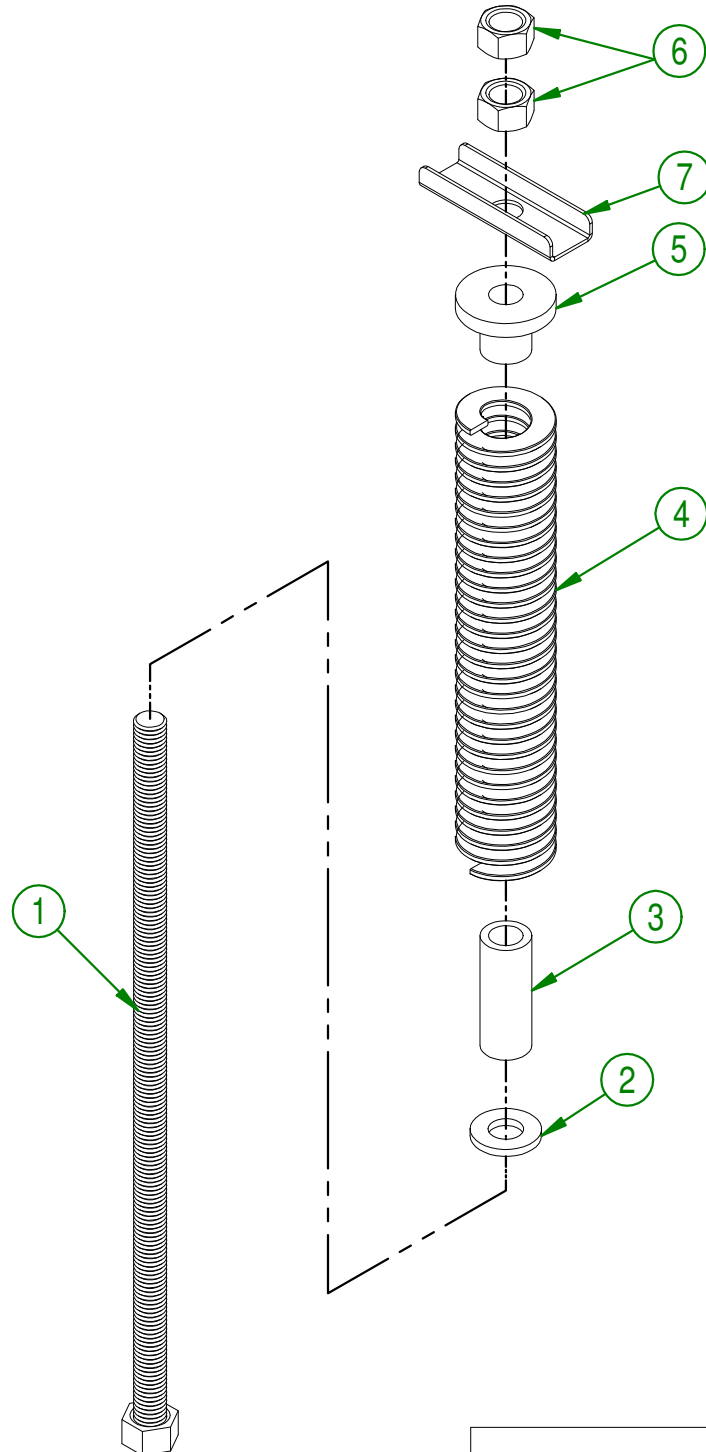

<b>AGRIMETAL</b>		
<b>ASSEMBLY BELT TENSIONER</b>		
CREATION : 2016-06-21	ASSEMBLY :	32-57-3540
REVISION : 2018-01-09	AUTHOR : S.B.	Page 10 de 15

#	# DE PIÈCE	Qty	TITLE
1	32-50-3040	1	WELD ASSEMBLY BRACKET BELT COVER
2	NC01-04-0107	2	CARR. BOLT GR2 ZINC 3/8-16 X 3/4"
3	NC02-32-0012	2	LOCK WASHER ZINC 3/8"
4	NC02-07-0018	2	HEX. NUT ZINC 3/8-16

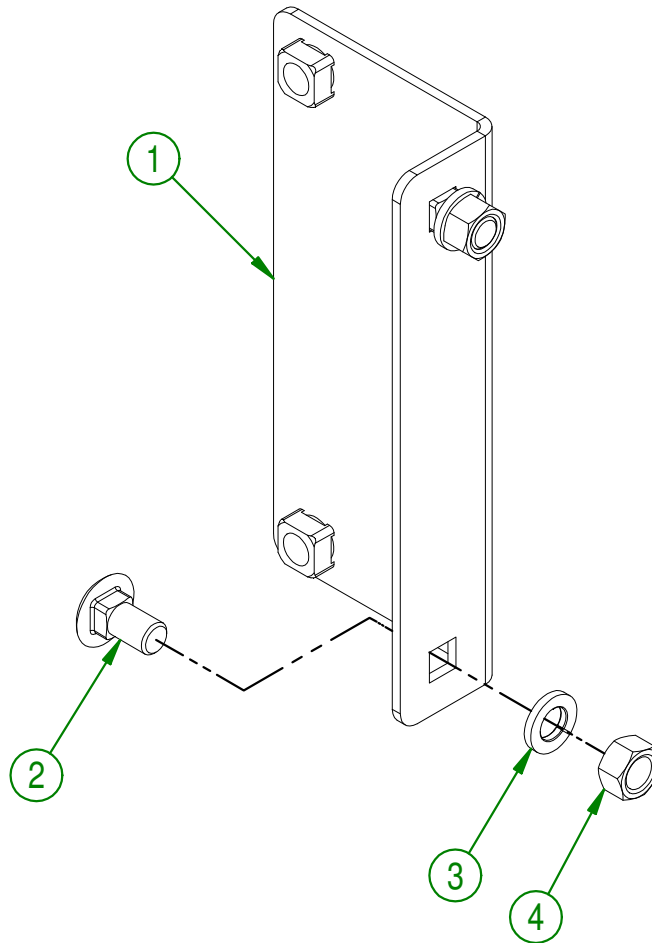

<b>AGRIMETAL</b>		
<b>ASSEMBLY BRACKET BELT COVER</b>		
CREATION : 2016-06-21	ASSEMBLY :	32-57-3055
REVISION : 2018-01-09	AUTHOR : S.B.	Page 11 de 15

#	PART #	Qty	TITLE
1	NCI7-94-0008	1	IMPELLER SHAFT
2	NCI4-75-0025	1	FLANGE BEARING 4 HOLES UCF 208-24 X 1 1/2"
3	NC01-17-0396	4	HEX. BOLT GR2 ZINC 5/8-11 X 2"
4	NC02-32-0016	4	LOCK WASHER ZINC 5/8"
5	NC02-07-0022	4	HEX. NUT ZINC 5/8-11
6	32-09-2000	3	IMPELLER SPACER
7	NCI4-75-0024	1	FLANGE BEARING 4 HOLES UCF207-20 1 1/4" DIA.
8	12-01-3051	1	REAR BEARING PROTECTOR
9	NC01-17-0250	4	HEX. BOLT GR2 ZINC 1/2-13 X 1 3/4"
10	NC02-25-0011	4	WASHER SAE ZINC 17/32 ID
11	NC02-32-0014	4	LOCK WASHER ZINC 1/2"
12	NC02-07-0020	4	HEX. NUT ZINC 1/2-13
13	32-55-3050	1	IMPELLER
14	NC01-98-0022	1	NYLON NUT HEX. 1 3/8-12 THIN
15	NCI4-62-0202	1	PULLEY QD 3VI/2-5/8 X 7.35 OD X SK (3B70)
16	NCI4-62-0021	1	QD BUSHING SK 1 1/2"
17	32-41-0900	1	IMPELLER KEY
18	12-41-0915	1	PULLEY KEY

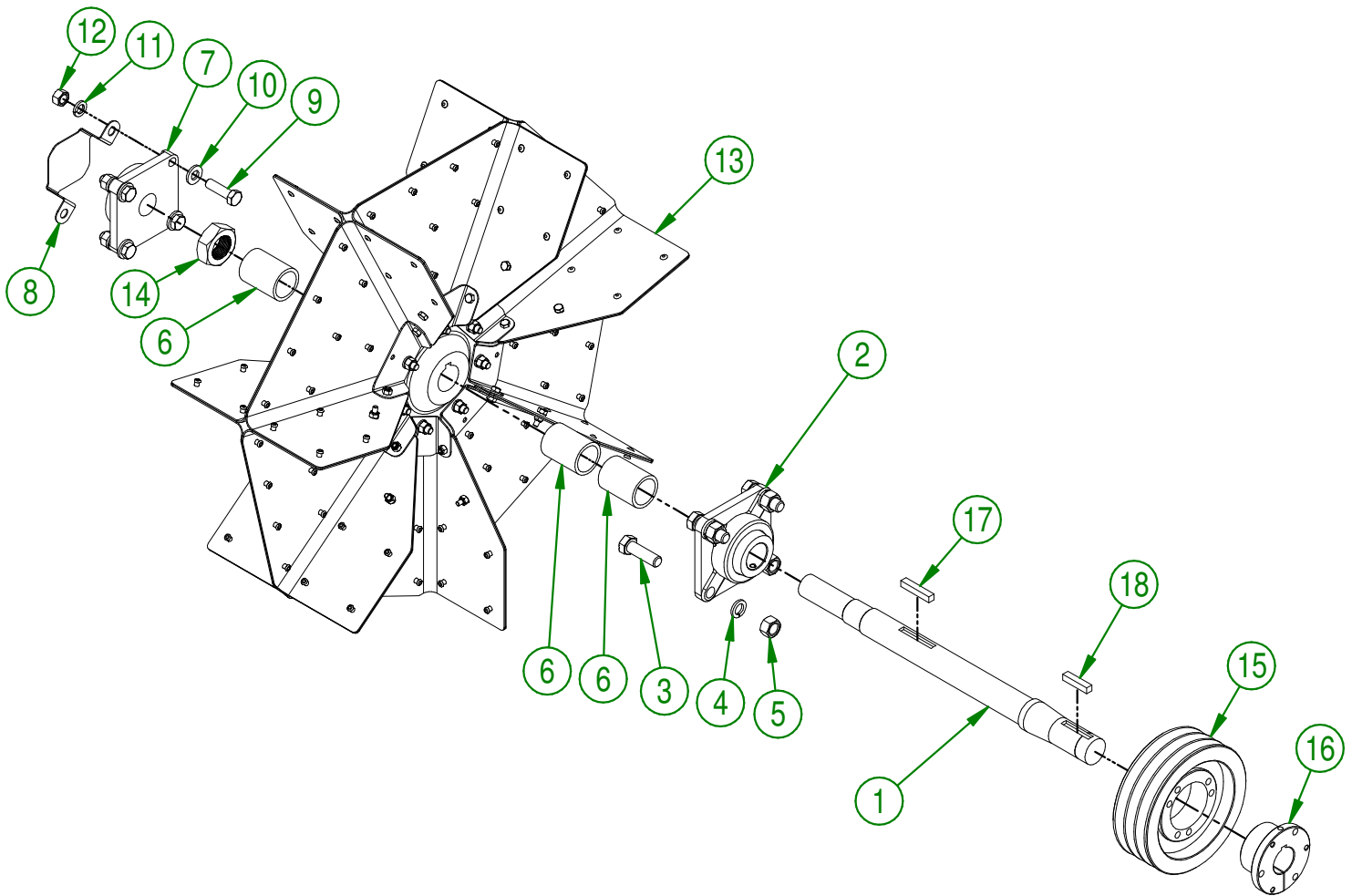

USE THESE PIECES ONLY IF YOUR SERIAL NUMBER IS AFFECTED:

#39750 AND UNDER

AGRIMETAL	
ASSEMBLY IMPELLER	
CREATION : 2016-06-21	ASSEMBLY : 32-57-3545
REVISION : 2021-02-15	AUTHOR : S.B.

32-57-3546

#	PART #	Qty	TITLE
1	NC14-75-0025	1	FLANGE BEARING 4 HOLES UCF 208-24 X I 1/2"
2	NC01-17-0396	4	HEX. BOLT GR2 ZINC 5/8-11 X 2"
3	NC02-32-0016	4	LOCK WASHER ZINC 5/8"
4	NC02-07-0022	4	HEX. NUT ZINC 5/8-11
5	NC14-75-0024	1	FLANGE BEARING 4 HOLES UCF207-20 I 1/4" DIA.
6	12-01-3051	1	REAR BEARING PROTECTOR
7	NC01-17-0250	4	HEX. BOLT GR2 ZINC 1/2-13 X I 3/4"
8	NC02-25-0011	4	WASHER SAE ZINC 17/32 ID
9	NC02-32-0014	4	LOCK WASHER ZINC 1/2"
10	NC02-07-0020	4	HEX. NUT ZINC 1/2-13
11	32-57-6000	1	IMPELLER
12	NC14-62-0202	1	PULLEY QD 3VI/2-5/8 X 7.35 OD X SK (3B70)
13	NC14-62-0021	1	QD BUSHING SK I 1/2"
14	12-41-0915	1	PULLEY KEY

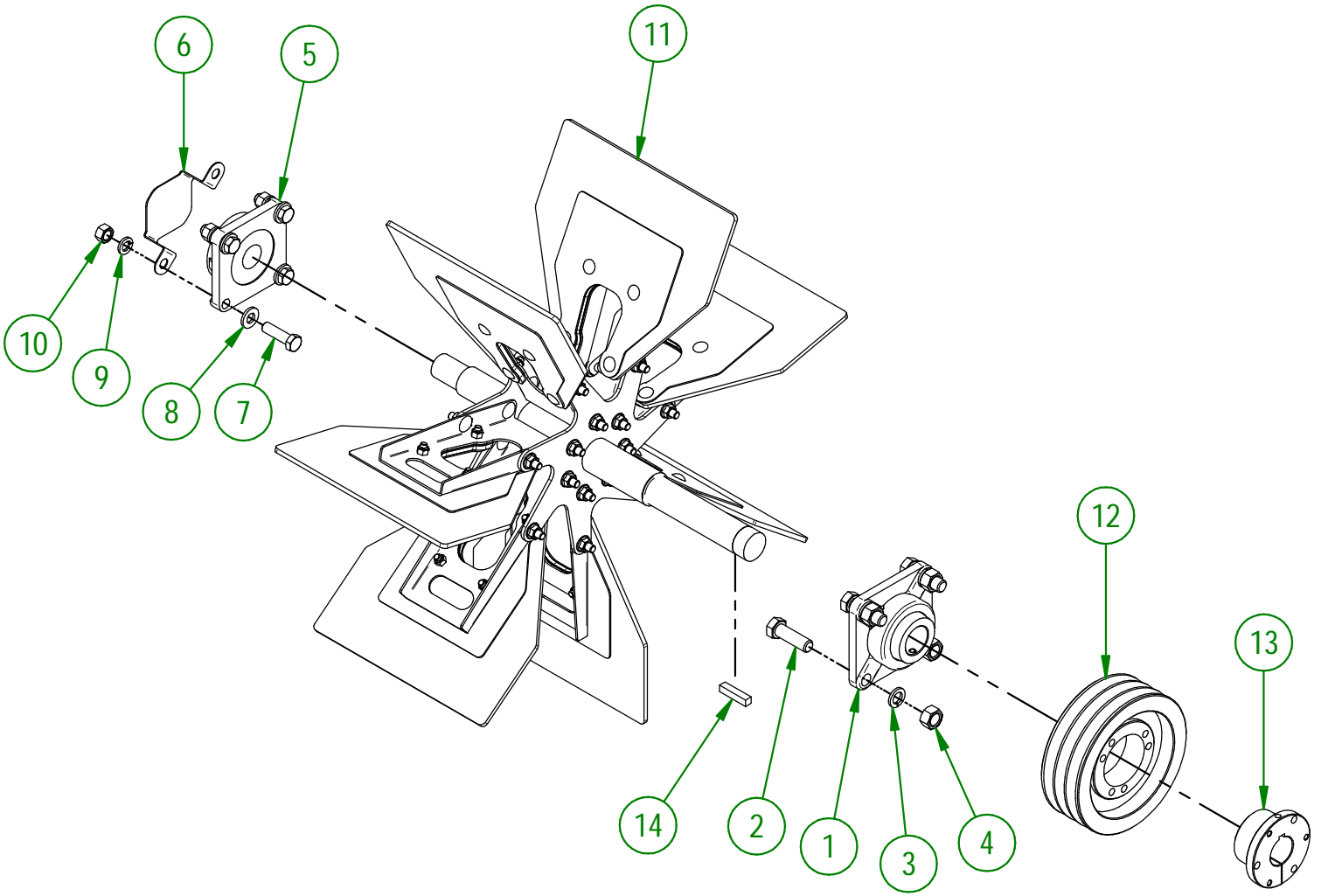

USE THESE PIECES ONLY IF YOUR SERIAL NUMBER IS AFFECTED:

BETWEEN #39751 AND #45452

**AGRIMETAL**  
**ASSEMBLY IMPELLER**

CREATION : 15/02/21  
REVISION : 19/03/24

ASSEMBLY : **32-57-3546**  
AUTHOR : J. Houle

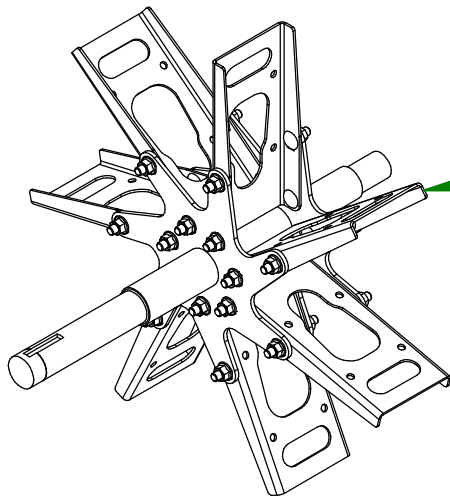

32-50-6000  
IMPELLER FRAME

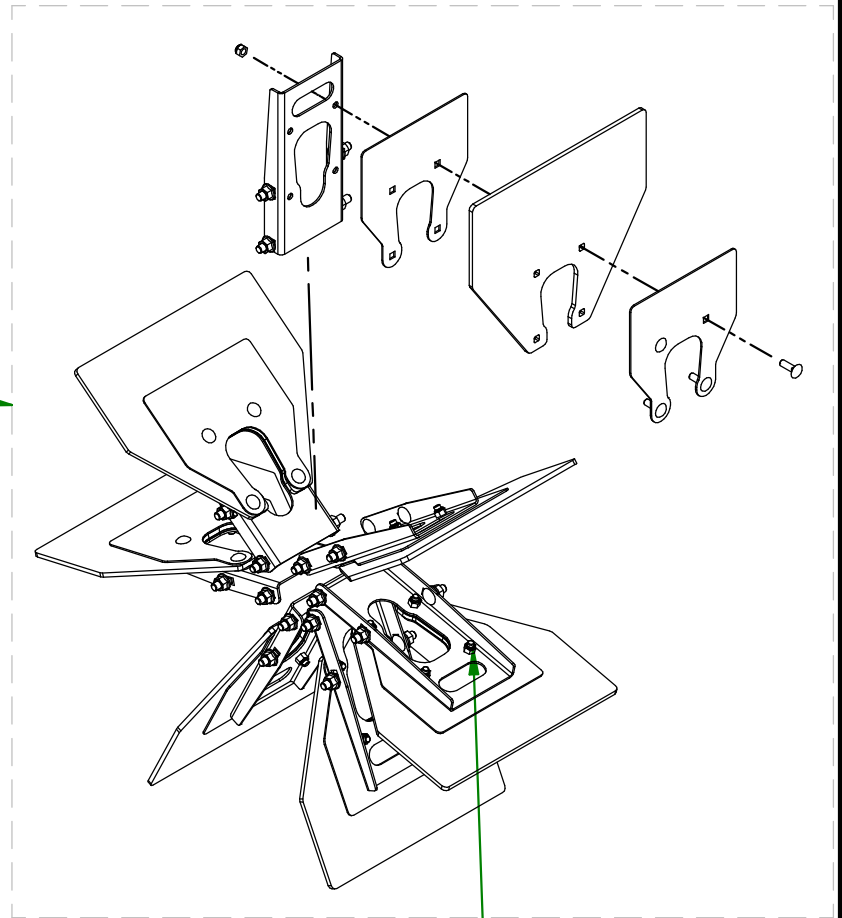

32-57-6010  
IMPELLER PADDLE AND  
PADDLE REINFORCEMENT GROUP

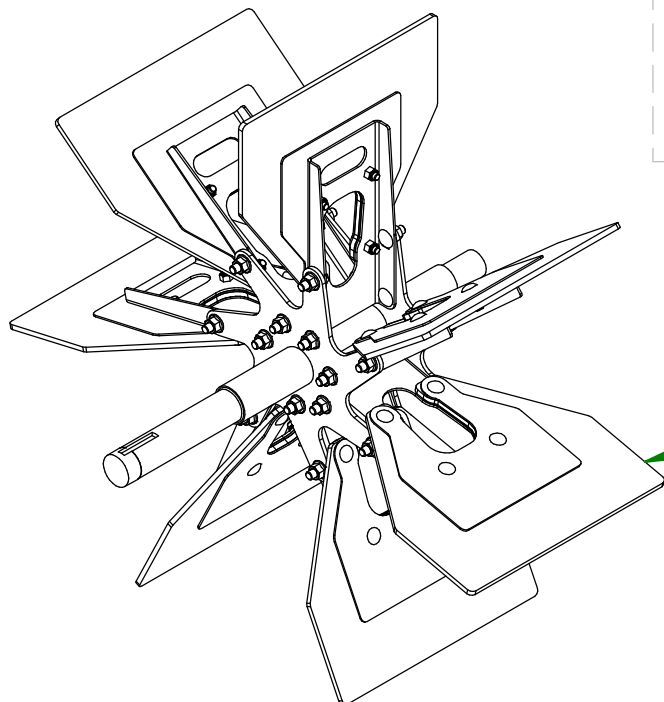

32-57-6000  
IMPELLER

TORQUE AT  
120 INCH POUNDS

USE THESE PIECES ONLY IF YOUR SERIAL  
NUMBER IS AFFECTED:

BETWEEN #39751 AND #45452

**AGRIMETAL**  
**IMPELLER**

CREATION : 06/10/20  
REVISION : 19/03/24

ASSEMBLY : **32-57-6000**  
AUTHOR : J. Houle

32-57-3547

#	PART #	Qty	TITLE
1	NC14-75-0025	1	FLANGE BEARING 4 HOLES UCF 208-24 X 1 1/2"
2	NC01-17-0396	4	HEX. BOLT GR2 ZINC 5/8-11 X 2"
3	NC02-32-0016	4	LOCK WASHER ZINC 5/8"
4	NC02-07-0022	4	HEX. NUT ZINC 5/8-11
5	NC14-75-0024	1	FLANGE BEARING 4 HOLES UCF207-20 1 1/4" DIA.
6	12-01-3051	1	REAR BEARING PROTECTOR
7	NC01-17-0250	4	HEX. BOLT GR2 ZINC 1/2-13 X 1 3/4"
8	NC02-25-0011	4	WASHER SAE ZINC 17/32 ID
9	NC02-32-0014	4	LOCK WASHER ZINC 1/2"
10	NC02-07-0020	4	HEX. NUT ZINC 1/2-13
11	32-57-6001	1	IMPELLER
12	NC14-62-0202	1	PULLEY QD 3VI/2-5/8 X 7.35 OD X SK (3B70)
13	NC14-62-0021	1	QD BUSHING SK 1 1/2"
14	12-41-0915	1	PULLEY KEY

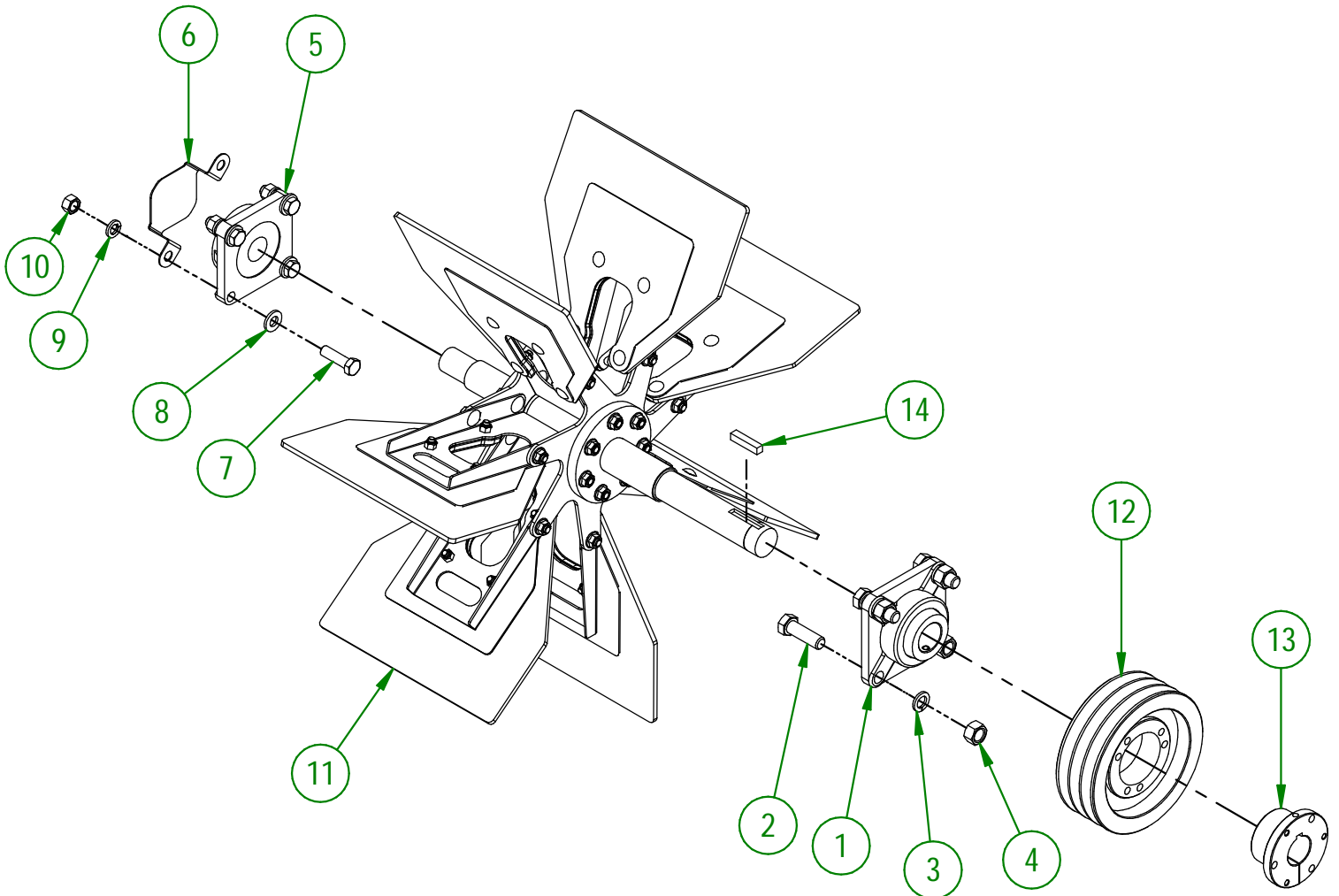

USE THESE PIECES ONLY IF YOUR SERIAL NUMBER IS AFFECTED:

#45453 AND ABOVE

<b>AGRIMETAL</b>	
<b>REGROUP. ARBRE DE PROPULSEUR</b>	
CREATION : 22/02/24	ASSEMBLY : <b>32-57-3547</b>
REVISION : 19/03/24	AUTHOR : J. Houle



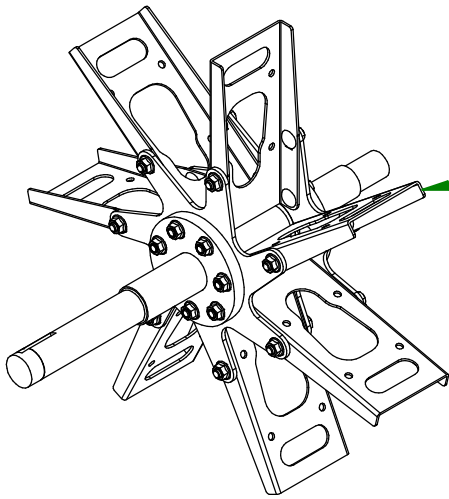

32-50-6001  
IMPELLER FRAME

32-57-6011  
IMPELLER PADDLE AND  
PADDLE REINFORCEMENT GROUP

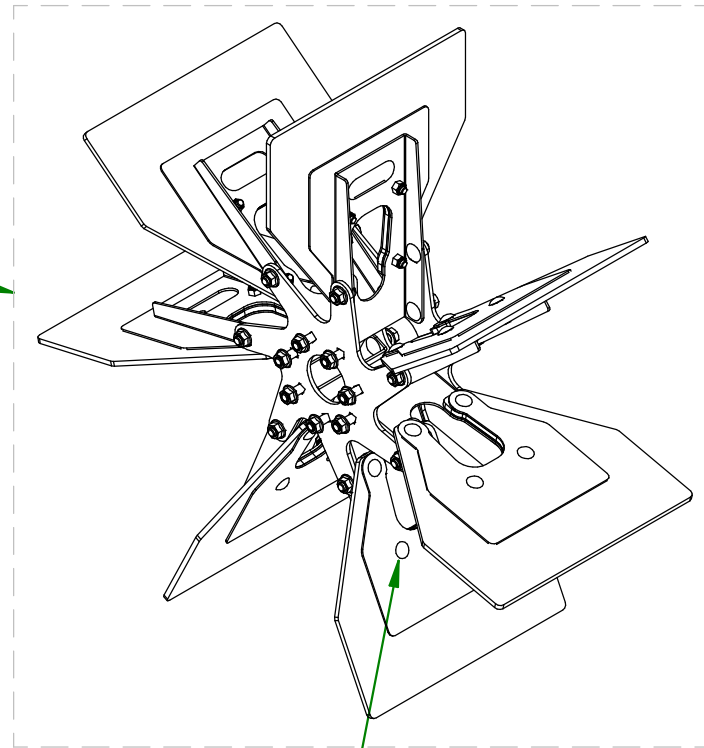

TORQUE AT  
120 INCH POUNDS

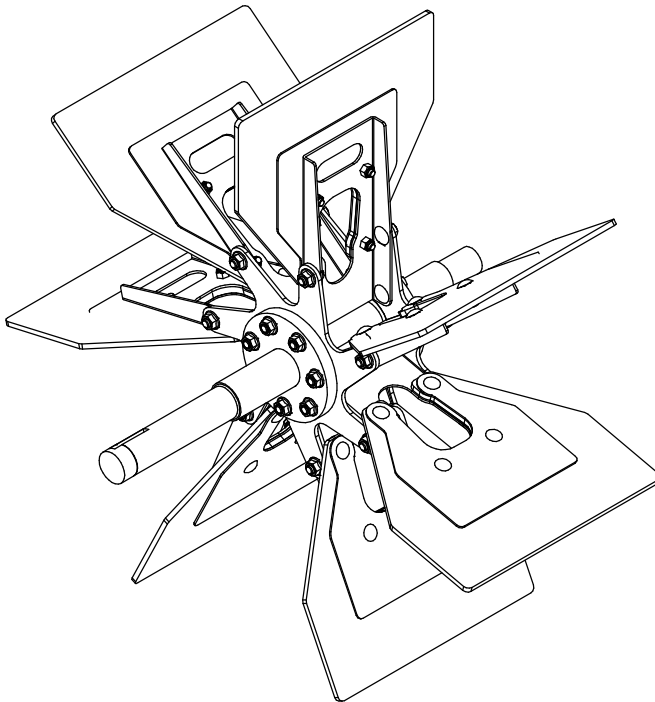

32-57-6001  
IMPELLER

USE THESE PIECES ONLY IF YOUR SERIAL  
NUMBER IS AFFECTED:

#45453 AND ABOVE

**AGRIMETAL**  
**IMPELLER**

CREATION : 19/03/24  
REVISION : 19/03/24

ASSEMBLY : **32-57-6001**  
AUTHOR : J. Houle

32-57-3550

#	PART #	Qty	TITLE
1	32-57-3505	1	WELD ASSEMBLY COVER CASING
2	NC01-04-0107	8	CARR. BOLT GR2 ZINC 3/8-16 X 3/4"
3	NC02-14-0019	10	FLANGE NUT HEX. NC 3/8-16 GR. B

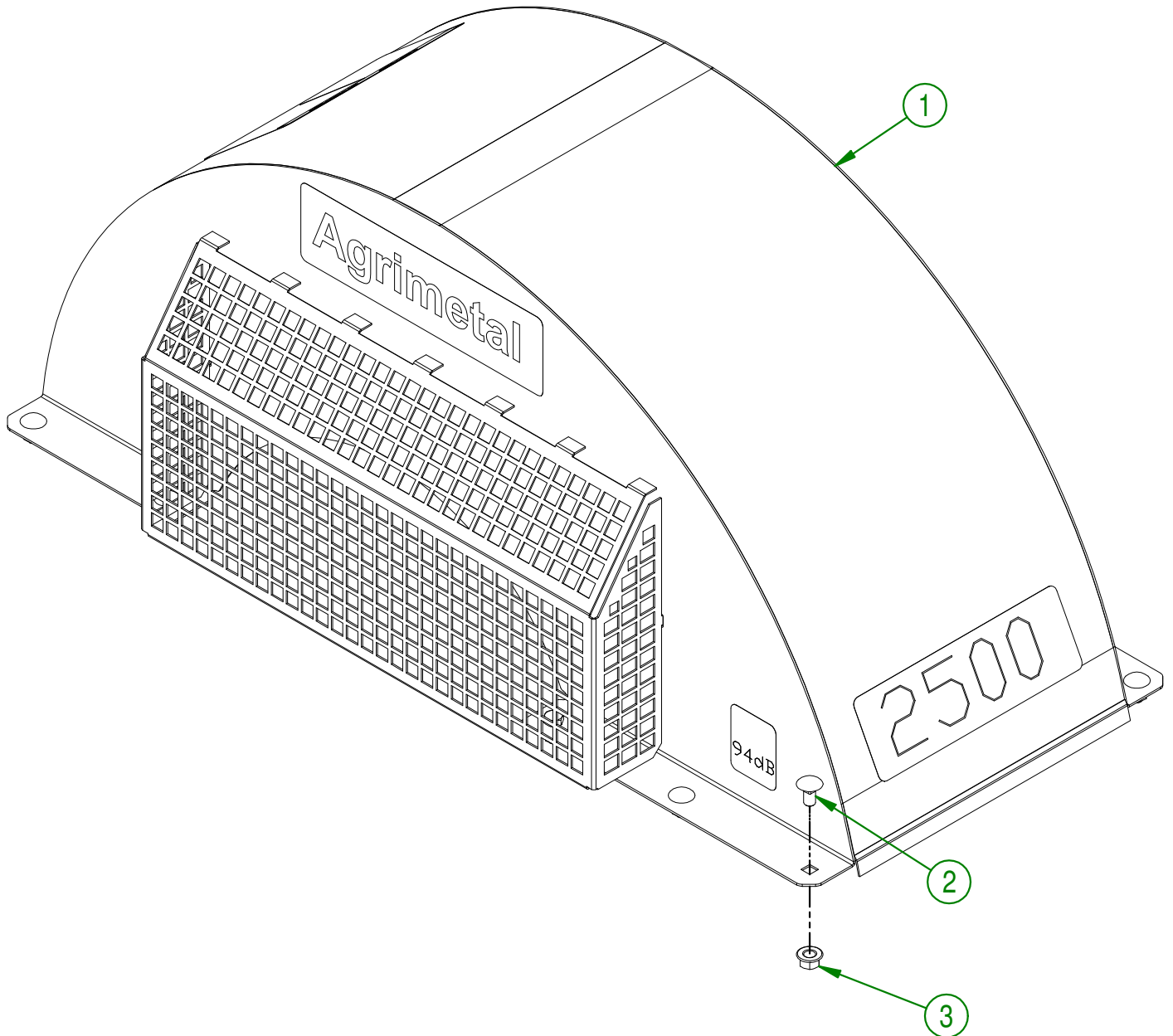

<b>AGRIMETAL</b>			
<b>ASSEMBLY COVER CASING</b>			
CREATION : 2016-06-21	ASSEMBLY :	32-57-3550	
REVISION : 2018-01-09	AUTHOR : S.B.	Page 13 de 15	

#	PART #	Qty	TITLE
1	NCI3-30-0237	1	PLASTIC TUBE FOR OPERATOR'S MANUAL
2	32-98-0530	1	OPERATOR MANUEL
3	NC01-04-0003	3	BOLT CARR. GR2 ZINC 1/4-20 X 3/4"
4	NC02-25-0007	3	WASHER ZINC 0.281 = 9/32
5	NC01-96-0009	3	NYLON-INSERT LOCKNUT ZINC 1/4-20
6	NCI3-25-0019	1	BLACK TIE RAP
7	NCI3-25-0287	1	18-14 GA BLUE CONNECTOR

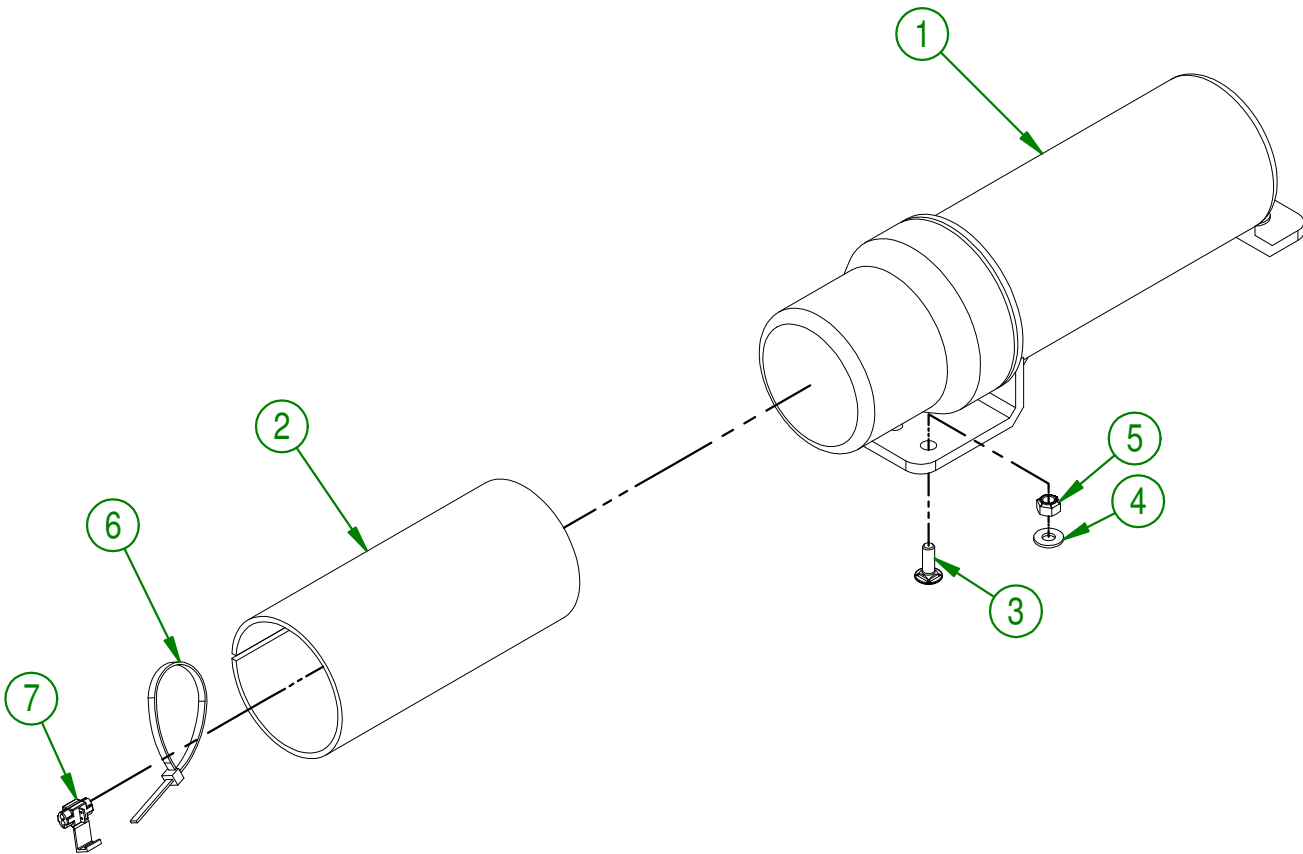

**AGRIMETAL**  
**OPERATOR MANUAL**

CREATION : 13/02/17  
 REVISION : 01/02/18

ASSEMBLY : **32-57-4110**

AUTHOR : F.HÉLIE Page 14 de 15

#	# DE PIÈCE	Qty	TITLE
1	NCI3-33-0112	1	STICKER DANGER
2	NCI3-33-0113	1	STICKER WARNING
3	NCI3-33-0163	1	STICKER LOW DECIBEL
4	NCI3-33-0024	6	STICKER GREASE HERE
5	NCI3-33-0154	1	STICKER IMPORTANT
6	NCI3-33-0035	2	STICKER AGRIMETAL
7	NCI3-33-0169	1	STICKER 94 DB
8	NCI3-33-0156	1	STICKER CAUTION
9	NCI3-33-0110	2	STICKER DANGER
10	NCI3-33-0158	2	STICKER 2500
11	NCI3-33-0018	1	STICKER WARNING
12	NCI3-33-0218	1	STICKER DANGER
13	NCI3-33-0179	1	STICKER IMPORTANT GREASE DRIVE LINE
14	NCI3-33-0298	2	STICKER PULL THIS WAY TO OPEN
15	NCI3-33-0133	1	STICKER DUCT POSITION UP DOWN

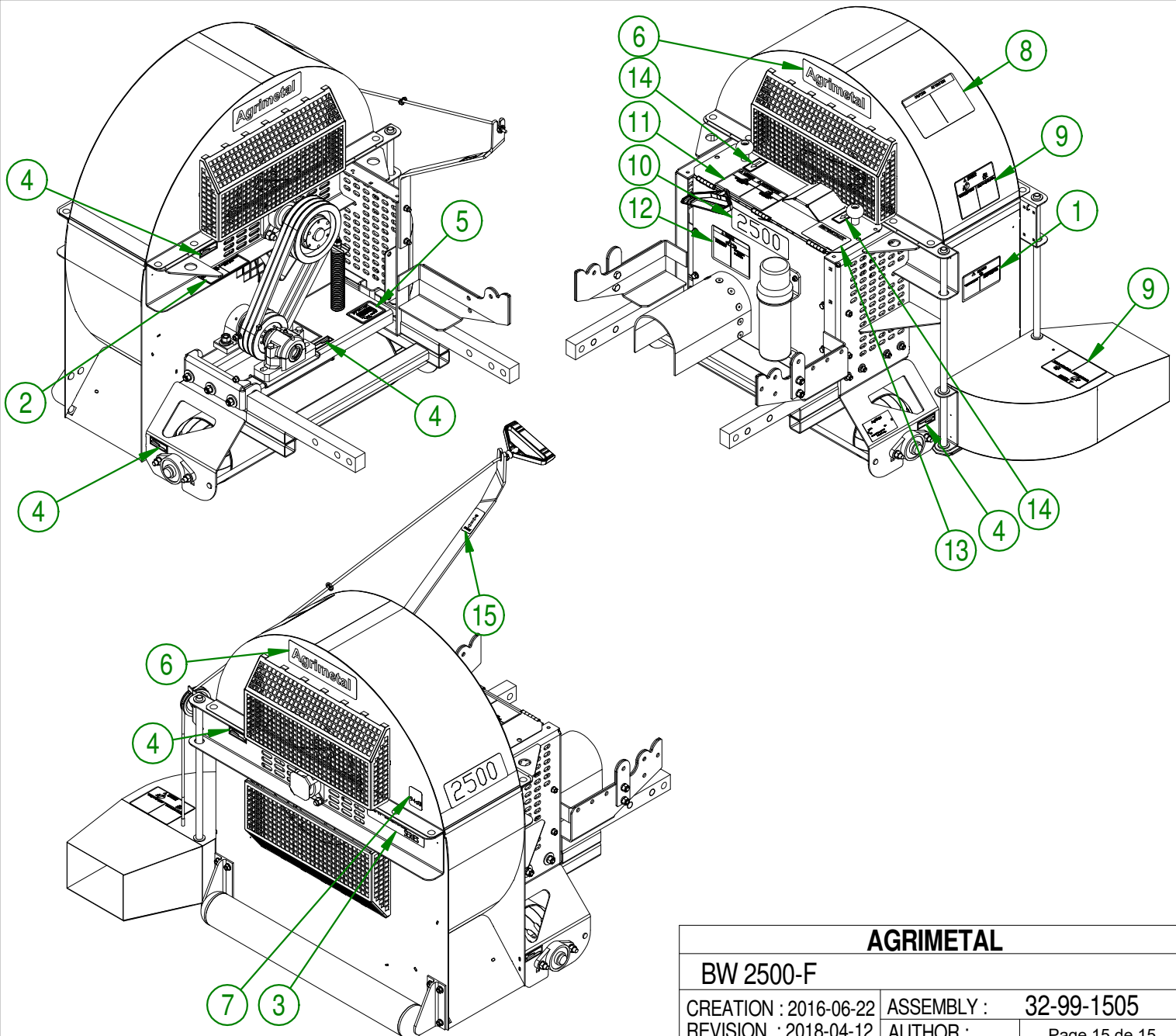

AGRIMETAL		
BW 2500-F		
CREATION : 2016-06-22	ASSEMBLY :	32-99-1505
REVISION : 2018-04-12	AUTHOR :	Page 15 de 15