

AgriMetal

PARTS LIST

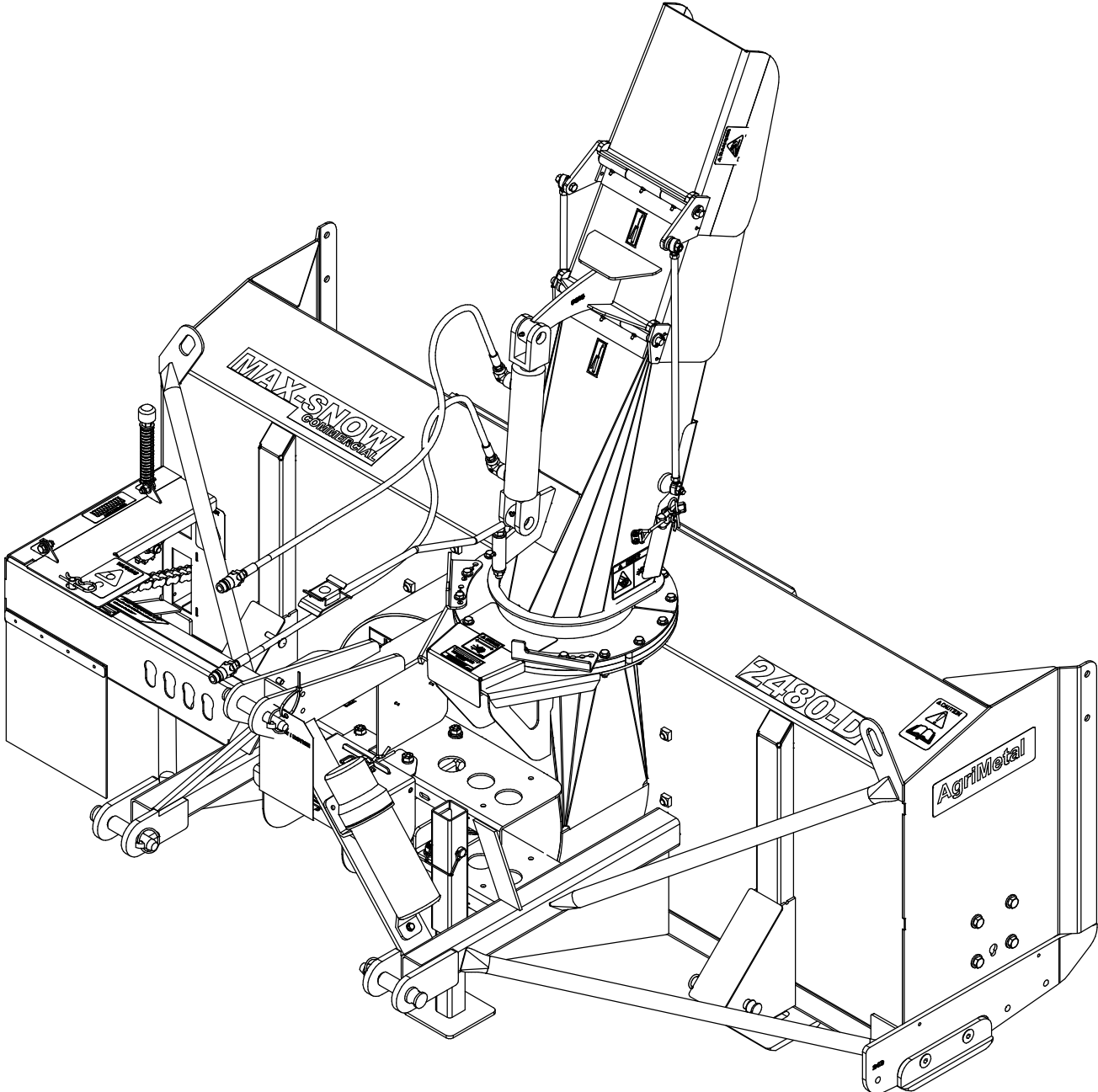

MS 2480-D

BEFORE THE SERIAL NUMBER #38027

82-57-1205

#	PART #	Qty	TITLE
1	82-50-1200	2	KNIFE BRACE (TOP)
2	82-42-0105	1	RIGHT KNIFE (UHMW)
3	82-42-0106	1	LEFT KNIFE (UHMW)
4	82-04-0310	2	KNIFE BRACE (UNDER)
5	NC02-48-0548	18	FLAT HEAD SOCKET CAP SCREW STAINLESS 1/2-13 X 2"
6	NC01-93-0014	22	LOCK NUT ZINC 1/2-13
7	82-42-0110	1	LATERAL KNIFE (LEFT)
8	82-42-0111	1	LATERAL KNIFE (RIGHT)
9	80-04-0185	6	WASHER
10	NC01-17-0394	6	HEX. BOLT GR2 ZINC 5/8-11 X 1 1/2"
11	NC02-25-0011	4	WASHER SAE ZINC 17/32 ID
12	NC01-17-0251	2	HEX. BOLT GR2 ZINC 1/2-13 X 2"
13	NC01-17-0250	2	HEX. BOLT GR2 ZINC 1/2-13 X 1 3/4"

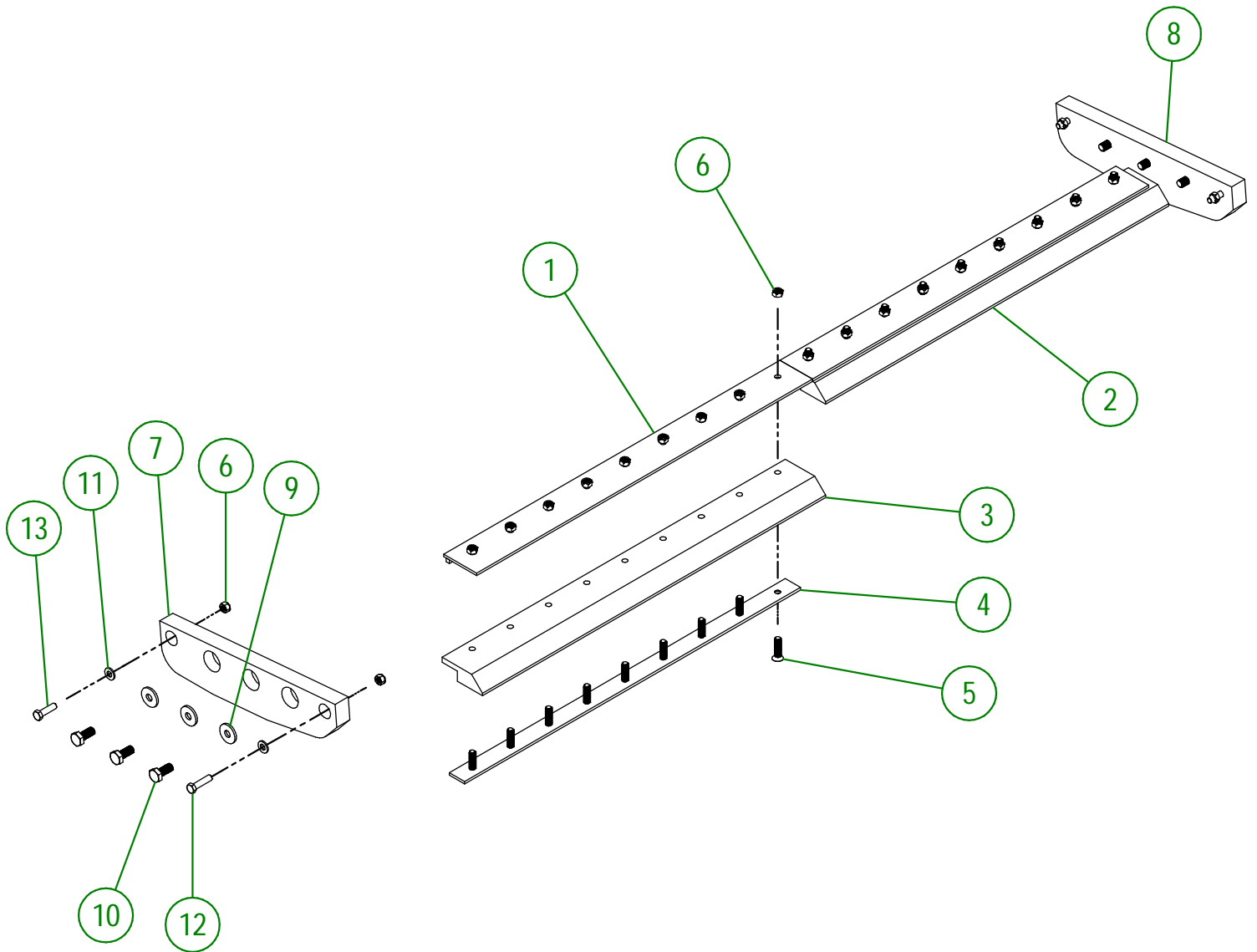

AGRIMETAL	
SET OF KNIVES (UHMW)	
CREATION : 19/07/16	ASSEMBLY : 82-57-1205
REVISION : 27/09/23	AUTHOR : J. HOULE

82-57-1200

#	PART #	Qty	TITLE
1	80-50-0085	2	LATERAL SKATE (#450 HARDNESS STEEL)
2	80-50-0055	2	ADJUSTABLE SKATE (STEEL)
3	NC02-48-0586	4	FLAT HEAD SOCKET CAP SCREW 5/8-11 X 1" LG
4	82-57-0060	2	KNIFE (#450 HARDNESS STEEL) GROUP (BOLTS AND NUTS INCLUDED)

82-57-0060

#	PART #	Qty	TITLE
5	NC01-09-0029	5	PLOW BOLT GR5 1/2-13 X 1 1/4" LG
6	NC01-93-0014	5	LOCK NUT ZINC 1/2-13

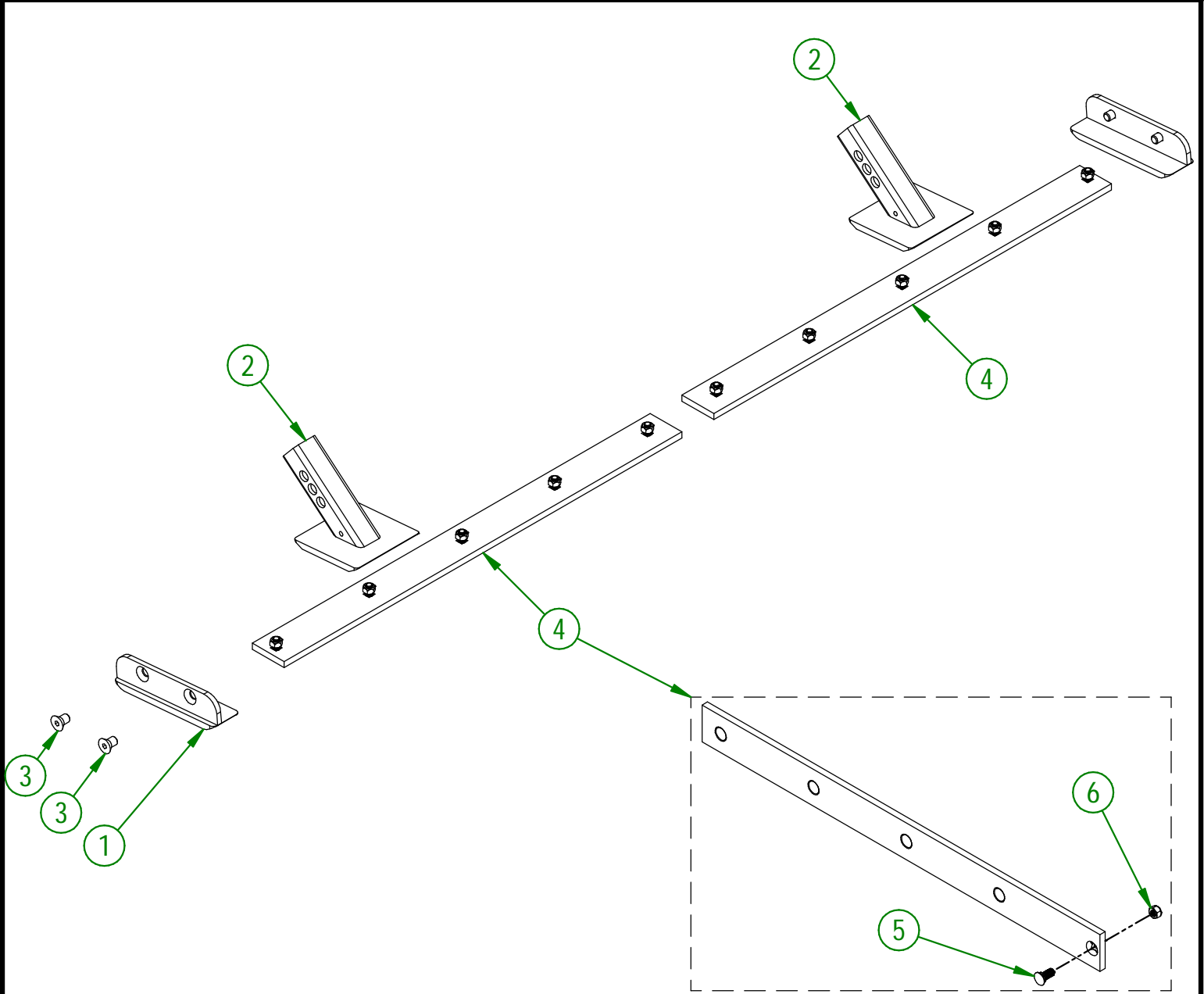

AGRIMETAL	
SET OF KNIVES (#450 HARDNESS STEEL)	
CREATION : 19/07/16	ASSEMBLY : 82-57-1200
REVISION : 26/09/23	AUTHOR : Dessin2

82-57-1210

#	PART #	Qty	TITLE
1	80-50-0087	2	LATERAL SKATE (STAINLESS STEEL)
2	80-50-0058	2	ADJUSTABLE SKATE (STAINLESS STEEL)
3	NC02-48-0586	4	FLAT HEAD SOCKET CAP SCREW 5/8-11 X 1"LG
4	82-57-0065	2	KNIFE (STAINLESS STEEL) GROUP (BOLTS AND NUTS INCLUDED)

82-57-0065

#	PART #	Qty	TITLE
5	NC01-93-0014	9	LOCK NUT ZINC 1/2-13
6	NC02-48-0545	9	FLAT HEAD SOCKET CAP SCREW 1/2"-13 X 1 1/4" (STAINLESS STEEL)

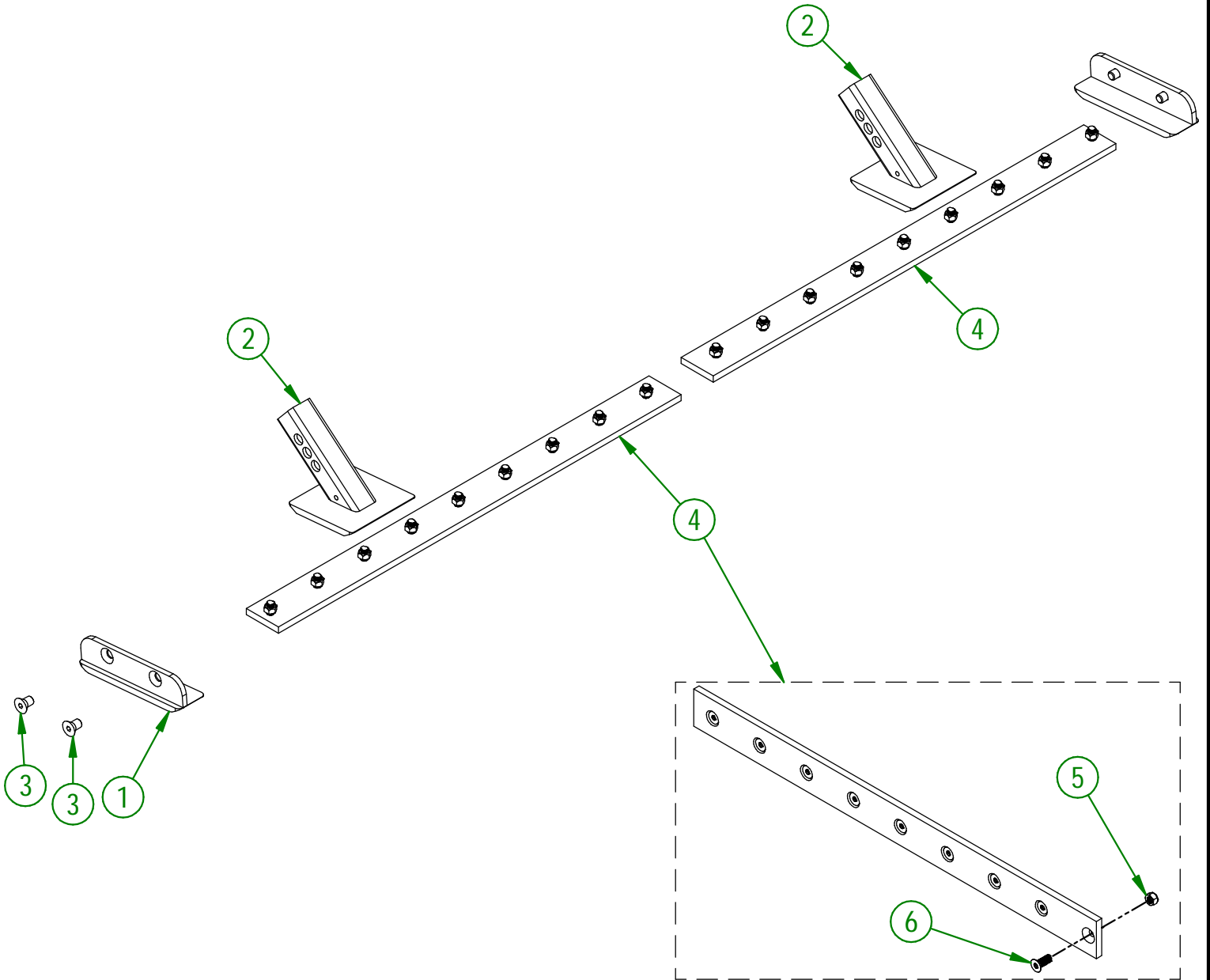

AGRIMETAL	
SET OF KNIVES (STAINLESS STEEL)	
CREATION : 19/07/16	ASSEMBLY : 82-57-1210
REVISION : 26/09/23	AUTHOR : Dessin2

#	PART #	Qty	TITLE
1	48-05-2105	2	LATERAL CUTTER BLADES
2	NC01-25-0248	4	HEX. BOLT GR5 ZINC 1/2-13 X 1 1/4"
3	NC02-32-0014	4	LOCK WASHER ZINC 1/2"
4	NC02-07-0020	4	HEX. NUT ZINC 1/2-13

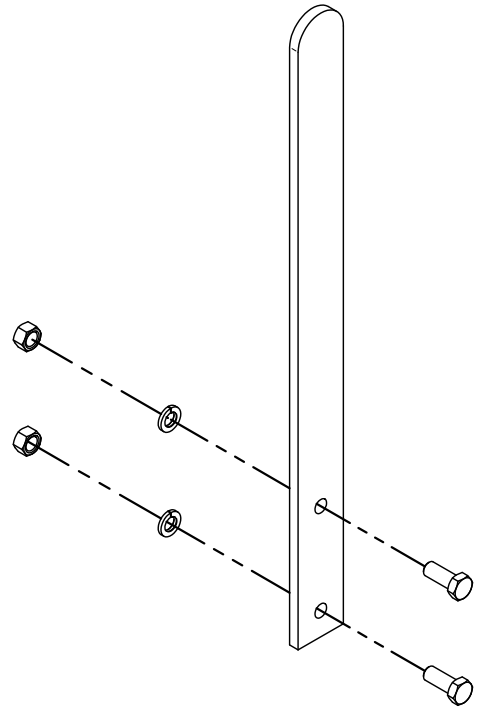
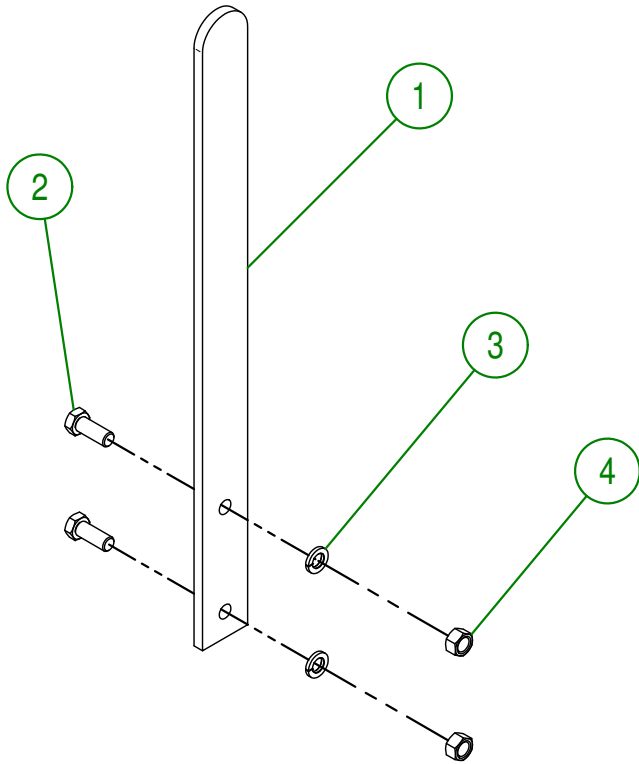

AGRIMETAL	
LATERAL CUTTER BLADES	
CREATION : 24/11/17	ASSEMBLY : 48-57-1235
REVISION : 22/10/18	AUTHOR : J. Houle Page 4 de 23

#	PART #	Qty	TITLE
1	80-55-0050	1	CHAIN CASE BOX (OPTION)
2	81-21-0030	4	CHAIN CASE SUPPORT
3	21-01-0950	8	FLAT WASHER 10GA 1.005" DIA X 25/64"
4	NC01-37-0122	4	HEX. BOLT. GR8 NF ZINC 3/8-24 X 3"
5	NC01-94-0011	4	LOCK NUT 3/8-24
6	82-01-0000	1	PTO GUARD
7	NC01-63-0027	1	HAIRPIN COTTER
8	NC01-37-0261	1	HEX. BOLT GR8 NF ZINC 1/2-20 X 4 1/2" LG
9	NC02-26-1300	10	WASHER 17/32-.531"ID X 1 1/2"OD
10	NC01-97-0008	1	HEX. LOCK NUT NYLO. NF Z 1/2-20

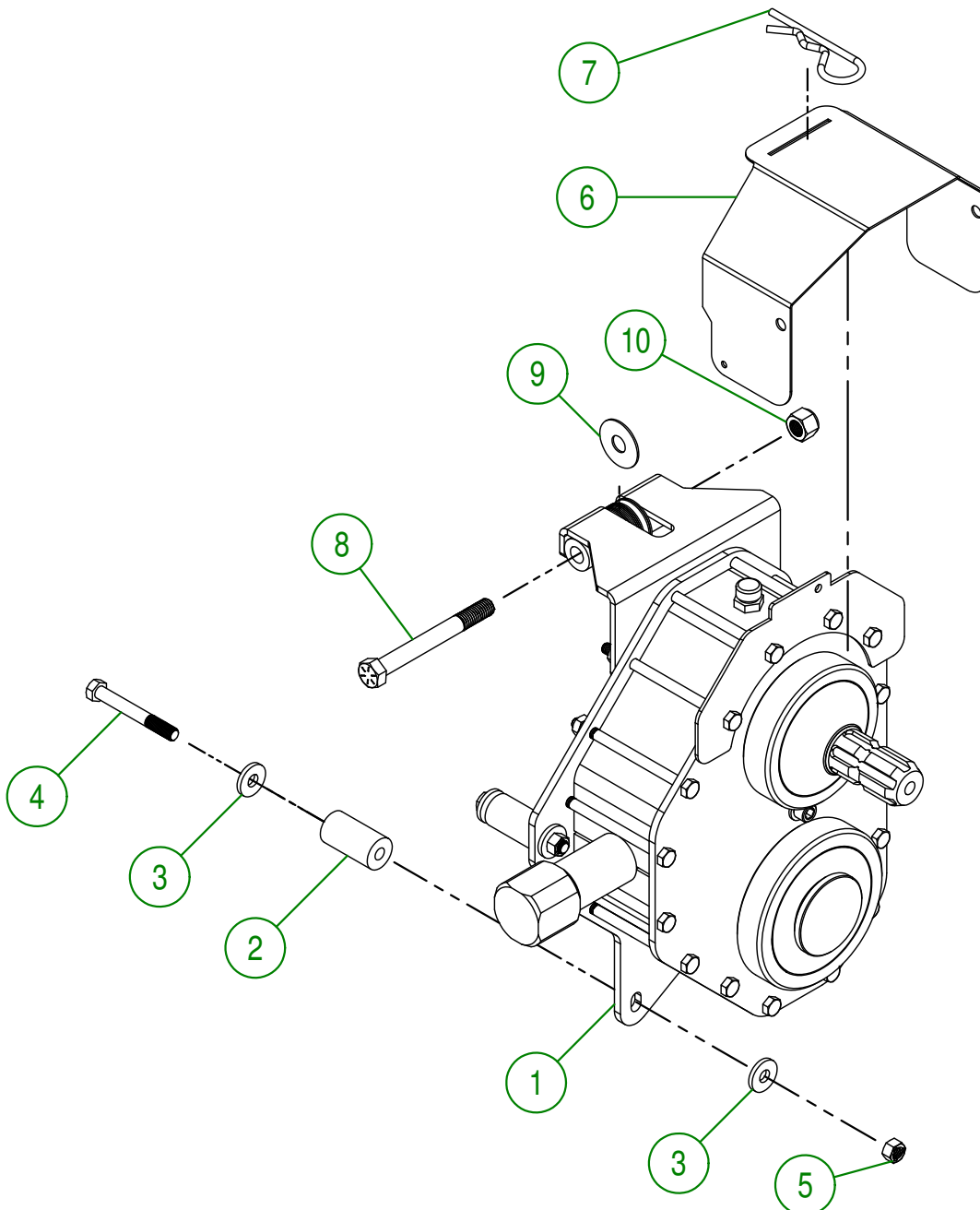

AGRIMETAL
CHAIN CASE GROUP.

CREATION : 10/04/18
REVISION : 29/05/19

ASSEMBLY : **82-57-2945**

AUTHOR : J.KABWE

Page 5 de 23

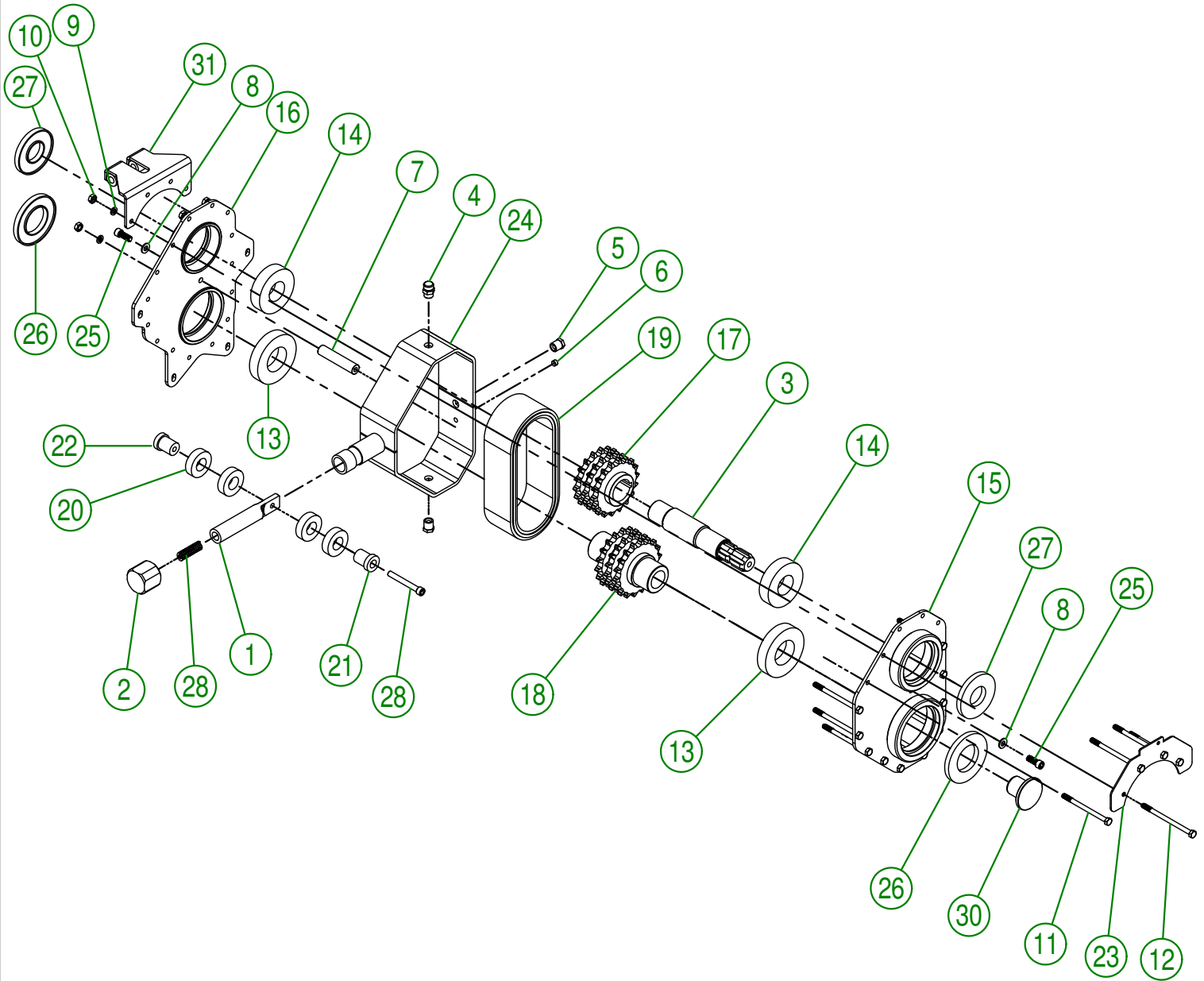

AGRIMETAL	
CHAIN CASE BOX (OPTION)	
CREATION : 05/04/18	ASSEMBLY : 80-55-0050
REVISION : 29/05/19	AUTHOR : J.KABWE Page 6 de 23

#	PART #	Qty	TITLE
1	80-20-0045	1	CHAIN TIGHTENER
2	81-21-0025	1	CHAIN CASE TIGHTENER PLUG
3	80-20-0015	1	SHAFT
4	NC14-10-0160	1	PLUG
5	NC13-45-0221	2	HEXAGONAL PLUG
6	NC02-44-0202	1	PRESSURE SCREW 6PANS NPTF 1/8-27
7	80-13-0010	1	COVER BRACE
8	49-22-1810	2	WASHER
9	NC02-32-0011	15	LOCK WASHER ZINC 5/16"
10	NC02-11-0017	15	HEX. NUT 5/16-24
11	NC01-37-0074	11	HEX. BOLT ZINC GR8 5/16-24 X 4 1/2"
12	NC01-37-0076	4	HEX. BOLT ZINC GR8 5/16-24 X 5"
13	NC14-75-0166	2	BEARING 6211-2RS
14	NC14-75-0167	2	BEARING 6308-2RC3
15	80-50-9010	1	CHAIN CASE FRONT
16	80-50-9005	1	CHAIN CASE BACK
17	80-50-9015	1	CHAIN CASE PINION (TOP)
18	80-50-9020	1	CHAIN CASE PINION (BOTTOM)
19	80-37-0000	1	CHAIN TRIPLE #60
20	NC14-70-0085	4	BEARING #6205 X 1"
21	80-13-0015	1	CHAIN CASE TIGHTENER RING
22	80-13-0017	1	CHAIN CASE TIGHTENER RING
23	80-01-0000	1	PTO GUARD SUPPORT
24	80-50-9000	1	BOX SIDE
25	NC02-51-0618	2	SOCKET HEAD SCREW 3/8-24 X 1 STAINLESS
26	NC13-80-0278	2	SEALING GASKET 10MM X 55MM X 100MM
27	NC13-80-0279	2	SEALING GASKET 10MM X 40MM X 90MM
28	NC02-51-0126	1	SOCKET HEAD SCREW 3/8-24 X 3"
29	NC13-86-0008	1	BLUE SPRING (5/8" OD. X 4")
30	81-42-0000	1	HUB PLUG
31	80-50-2000	1	CHAINCASE BRACE

AGRIMETAL**CHAIN CASE BOX (OPTION)**

CREATION : 05/04/18
REVISION : 29/05/19

ASSEMBLY : **80-55-0050**

AUTHOR : J.KABWE

Page 7 de 23

#	PART #	Qty	TITLE
1	NCI3-15-0315	1	SNOW GUARD
2	80-50-0093	1	STAND
3	48-20-0070	2	3 POINT PIN
4	48-20-0075	1	3 POINT PIN
5	NC01-78-0016	4	ALUMINIUM BLIND POP RIVET STEEL MANDREL 0.187 X 0.690
6	NC01-63-0026	1	COTTER PIN ZC 5/32" X 3"
7	NC01-69-1306	1	LOCKING PIN 3/8" X 2 1/2" LG
8	82-01-0970	1	SNOW GUARD BRACE
9	21-09-1205	1	BUSHING
10	NC01-69-1100	3	LINCH PIN 3/8"
11	82-57-0502	1	FRAME
12	NCI3-15-0320	1	RUBBER
13	80-57-0060	1	RUBBER REINFORCEMENT
14	NC01-17-0060	5	HEX. BOLT GR2 ZINC 5/16-18 X 1"
15	NC01-93-0010	5	LOCK NUT ZINC 5/16-18
16	80-50-5020	2	3 POINTS HITCH
17	NC01-33-0404	4	HEX. BOLT GR8 ZINC 5/8-11 X 4" LG
18	NC02-22-0013	4	WASHER ZINC 5/8 ID X 1 1/2 OD
19	NC01-93-0016	4	LOCK NUT ZINC 5/8-11
20	NC02-07-0022	2	HEX. NUT ZINC 5/8-11
21	NC01-17-0395	2	HEX. BOLT GR2 ZINC 5/8-11 X 1 3/4"
22	80-13-0105	2	BUSHING
23	NC01-96-0017	2	HEX. LOCK NUT NYLO. NC 3/4-10
24	NC01-25-0481	2	HEX. BOLT GR5 NC 3/4-10 X 5"

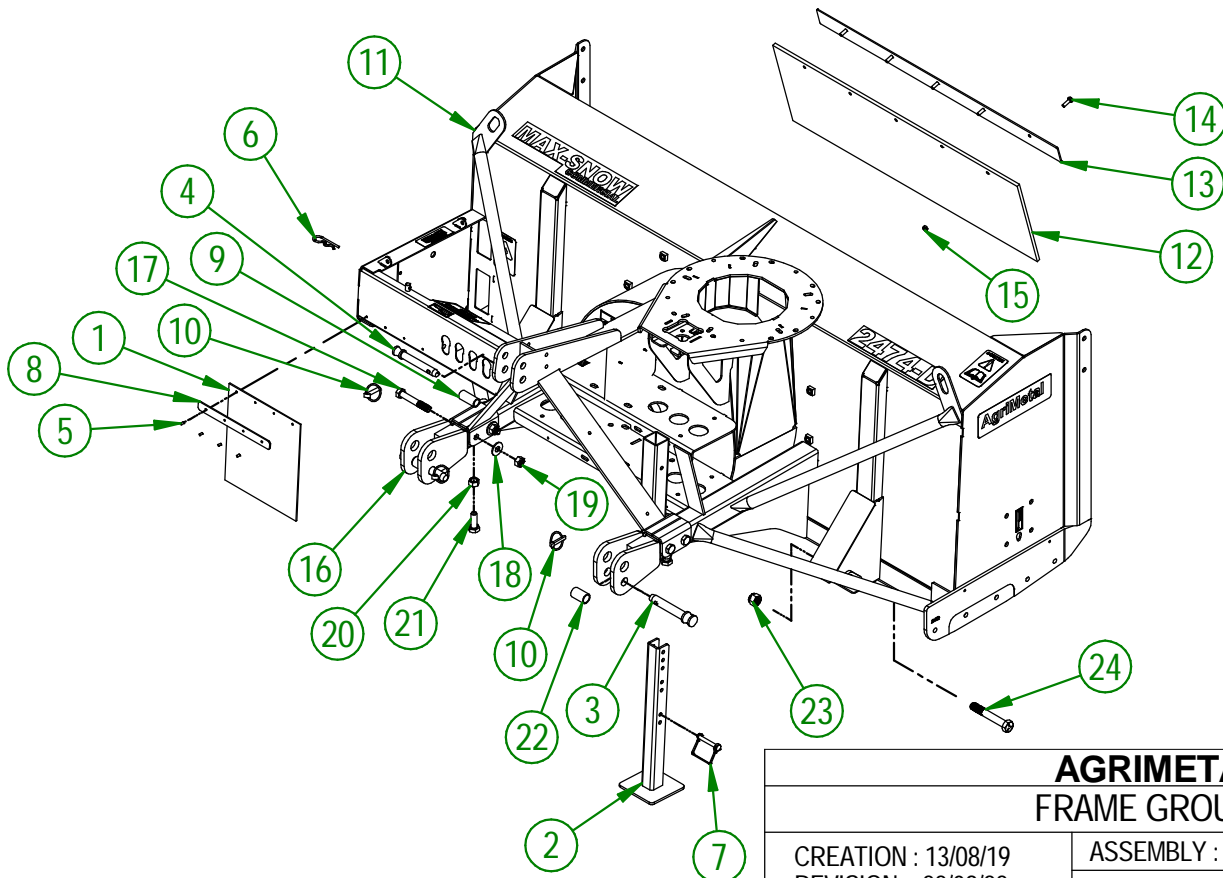

AGRIMETAL
FRAME GROUP

CREATION : 13/08/19
REVISION : 22/09/22

ASSEMBLY : **82-57-2441**
AUTHOR : F.HÉLIE

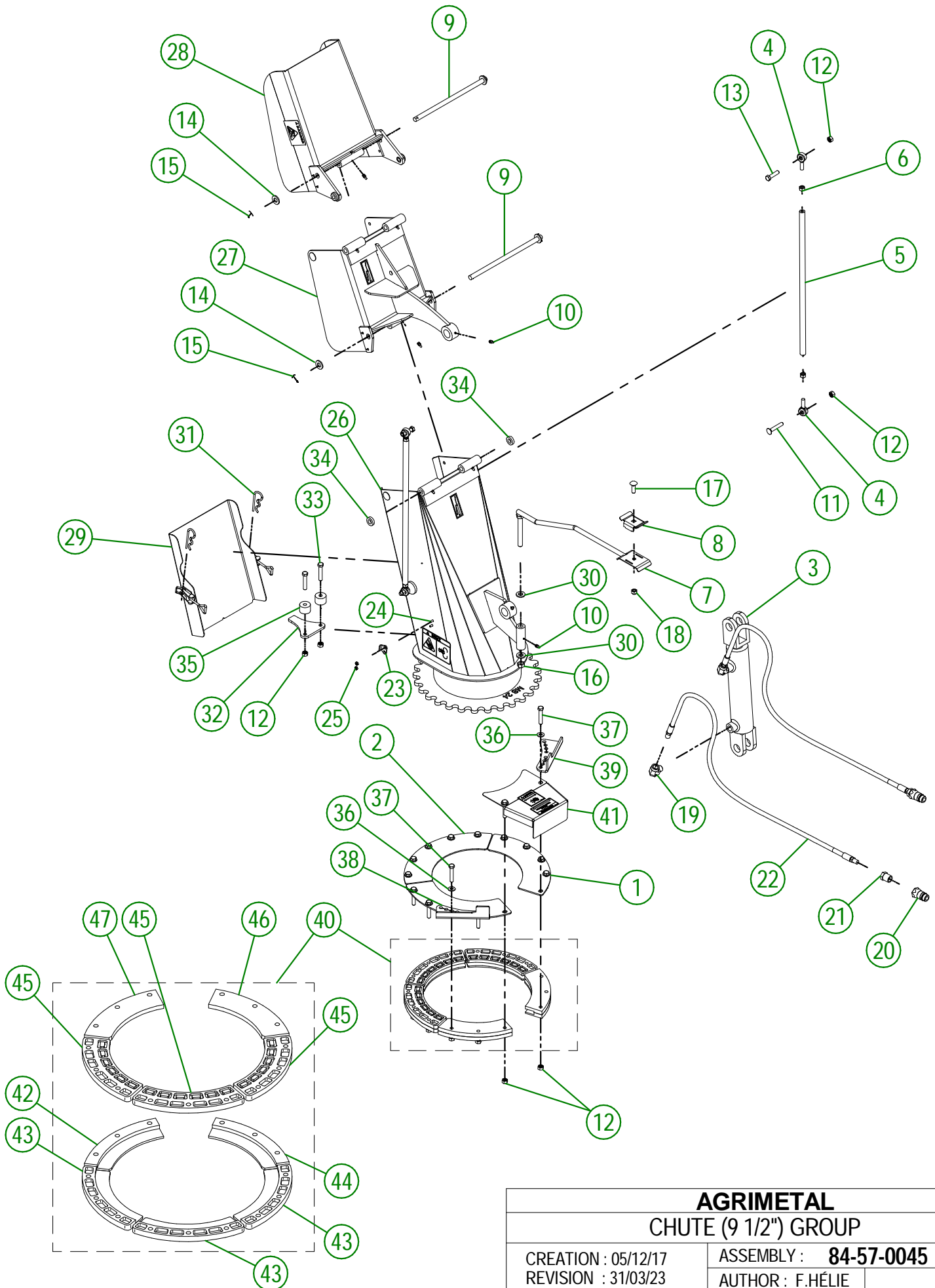

AGRIMETAL
CHUTE (9 1/2") GROUP

CREATION : 05/12/17
 REVISION : 31/03/23

ASSEMBLY : **84-57-0045**
 AUTHOR : F.HÉLIE

84-57-0045

#	PART #	Qty	TITLE
1	82-01-0965	2	BRACE
2	82-01-0955	1	BRACE
3	NC13-45-0209	1	HYDRAULIC CYLINDER 6"
4	NC01-67-0304	4	ROD END 3/8-24
5	48-13-0600	2	CHUTE ROD (DOUBLE)
6	NC02-10-0018	4	NUT 3/8-24
7	48-50-1030	1	HYDRAULIC HOSE SUPPORT
8	48-01-7530	1	HYDRAULIC HOSE SUPPORT
9	82-20-0250	2	PIVOT
10	NC01-69-0785	9	STRAIGHT GREASE FITTING 1/4-28
11	NC01-07-0113	2	CARR. BOLT GR5 ZINC 3/8-16 X 2" LG
12	NC01-93-0011	21	LOCK NUT 3/8-16
13	NC01-25-0116	2	HEX. BOLT GR5 ZINC 3/8-16 X 1 1/2"
14	NC02-25-0011	4	WASHER SAE ZINC 17/32 ID
15	NC01-69-0139	4	COTTER PIN ZINC 1/8" X 3/4"
16	NC01-96-0014	1	NYLON-INSERT LOCKNUT ZINC 1/2-13
17	NC01-04-0110	1	CARR. BOLT GR2 ZINC 3/8-16 X 1 1/4"
18	NC01-96-0011	1	NYLON NUT 3/8-16
19	NC13-45-0038	2	ELBOW 90 3/8 FEM. NPT X 3/8 MALE NPT
20	NC13-45-0369	2	QUICK COUPLER 1/2-14 NPTF
21	NC13-45-0153	2	HEX. REDUCER 1/4 NPT X 1/2 NPT
22	NC17-02-0329	2	HYDRAULIC HOSE (87" LG)
23	NC01-63-0052	2	ADJUSTABLE LATCH (STRIKE)
24	NC02-40-0080	4	MACHINE SCREWS SQUARE SOCKET #10-24 X 1/2" LG
25	NC01-96-0006	4	NYLON NUT ZINC 3/16
26	84-57-0300	1	CHUTE (BOTTOM SECTION)
27	82-57-0311	1	CHUTE (MIDDLE SECTION)
28	82-57-0321	1	CHUTE (TOP SECTION)
29	82-57-0352	1	CHUTE DOOR
30	01-01-0925	2	WASHER
31	NC01-63-0026	2	COTTER PIN ZC 5/32" X 3"
32	84-04-0195	1	STOPPER
33	NC01-37-0118	2	HEX. BOLT GR8 ZINC 3/8-24 X 2"
34	NC13-15-0334	2	PIVOT WASHER
35	81-21-0040	2	ADJUSTABLE STOPPER SPACER
36	01-01-2485	15	FLAT WASHER 14 GA X 13/16"OD X 25/64" ID
37	NC01-17-0118	15	HEX. BOLT GR2 ZINC 3/8-16 X 2"
38	84-04-0180	1	ADJUSTABLE STOPPER
39	84-04-0183	1	ADJUSTABLE STOPPER
40	84-57-1325	1	CHUTE GUIDE GROUP
41	84-57-0500	1	SPROCKET GUARD GROUP "STICKER INCLUDED"

84-57-1325

#	PART #	Qty	TITLE
42	46-42-0107	1	CHUTE GUIDE (UNDER)
43	NC17-46-0030	3	CHUTE GUIDE (UNDER)
44	46-42-0106	1	CHUTE GUIDE (UNDER)
45	NC17-46-0029	3	CHUTE GUIDE (TOP)
46	46-42-0101	1	CHUTE GUIDE (TOP)
47	46-42-0102	1	CHUTE GUIDE (TOP)

#	PART #	Qty	TITLE
1	81-01-7600	1	HYDRAULIC HOSE SUPPORT
2	80-01-0020	1	HYDRAULIC HOSE SUPPORT
3	NC14-45-0156	1	HYDRAULIC MOTOR
4	48-50-1025	1	HYDRAULIC ENGINE SPROCKET
5	NC02-32-0012	6	LOCK WASHER ZINC 3/8"
6	NC01-17-0112	4	HEX. BOLT GR2 ZINC 3/8-16 X 3/4"
7	01-01-2485	2	FLAT WASHER 14 GA X 13/16"OD X 25/64" ID
8	NC01-17-0114	2	HEX. BOLT GR2 ZINC 3/8-16 X 1"
9	NC01-04-0111	1	CARR. BOLT GR2 ZINC 3/8-16 X 1 1/2"
10	NC02-07-0018	2	HEX. NUT ZINC 3/8-16
11	NC13-45-0367	2	45°-7/8-14 MALE O RING X 1/2 FEM.TOUR.NPT PT
12	NC13-45-0369	2	QUICK COUPLER 1/2-14 NPTF
13	NC17-02-0328	2	HYDRAULIC HOSE (63" LG)
14	80-13-0100	2	HYDRAULIC RESTRICTOR
15	NC13-45-0378	2	HYDRAULIC RESTRICTOR BUSHING
16	80-45-0000	2	HEX. REDUCER 1/4 NPT X 1/2 NPT
17	NC02-32-0011	1	LOCK WASHER ZINC 5/16"
18	NC01-45-0184	1	HEX. BOLT GR8.8 ZINC 8MM X 20MM
19	NC17-46-0031	1	HYDRAULIC MOTOR BUSHING
20	NC01-96-0011	1	NYLON NUT 3/8-16
21	NC02-44-0103	2	SET SCREW 5/16-18 X 3/8"
22	01-33-0010	1	WASHER

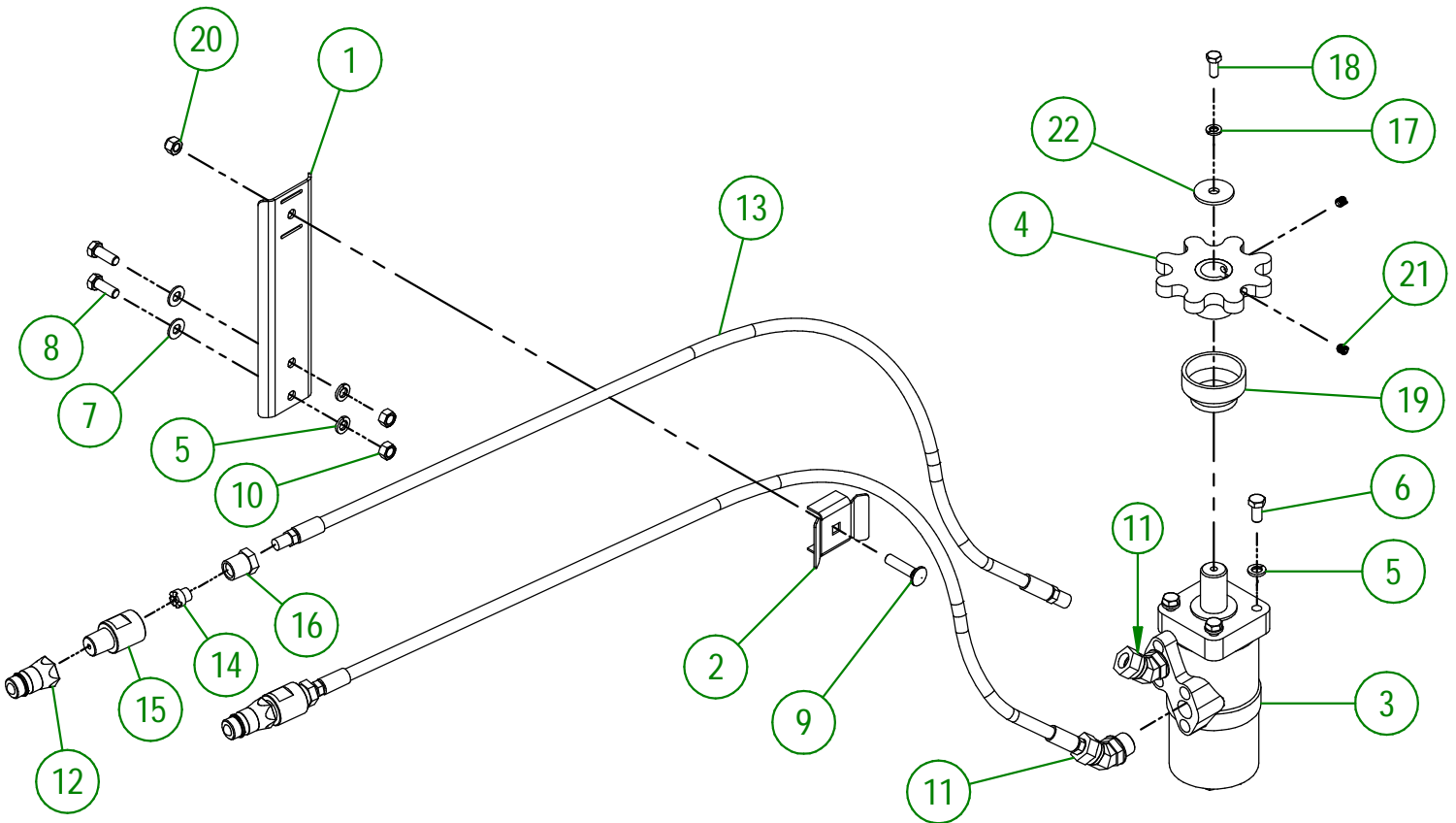

AGRIMETAL
HYDRAULIC MOTOR GROUP

CREATION : 2022-01-26
REVISION : 2022-03-28

ASSEMBLY : **80-57-0410**
AUTHOR : J. HOULE

#	PART #	Qty	TITLE
1	80-55-0010	1	GEARBOX
2	NC02-25-0011	14	WASHER SAE ZINC 17/32 ID
3	80-21-0010	4	TRANSMISSION BUSHING
4	NC02-32-0014	12	LOCK WASHER ZINC 1/2"
5	NC01-33-0248	4	HEX. BOLT .GR8 NC ZINC 1/2-13 X 1 1/4"
6	NC01-33-0251	4	HEX. BOLT GR8 NC ZINC 1/2-13 X 2"
7	80-41-0135	1	PTO GUARD STEEL CABLE
8	NC01-64-0005	2	OVAL SLEEVE (ALUMINUM)
9	80-41-0900	1	IMPELLER KEY
10	80-57-0040	1	PTO GUARD
11	NC13-50-0110	1	IMPORTANT/NOTICE PTO POSTER
12	NC13-25-0019	1	BLACK TIE RAP
13	80-34-0030	1	PTO SHAFT T60
14	NC01-63-0027	1	HAIRPIN COTTER
15	80-01-7526	1	PTO GUARD SUPPORT
16	80-04-0480	1	GEARBOX BRACE
17	80-04-0485	1	GEARBOX BRACE
18	NC01-33-0249	4	CAP SCREW GR8 NC ZINC 1/2-13 X 1 1/2" LG
19	NC02-07-0020	4	HEX. NUT ZINC 1/2-13

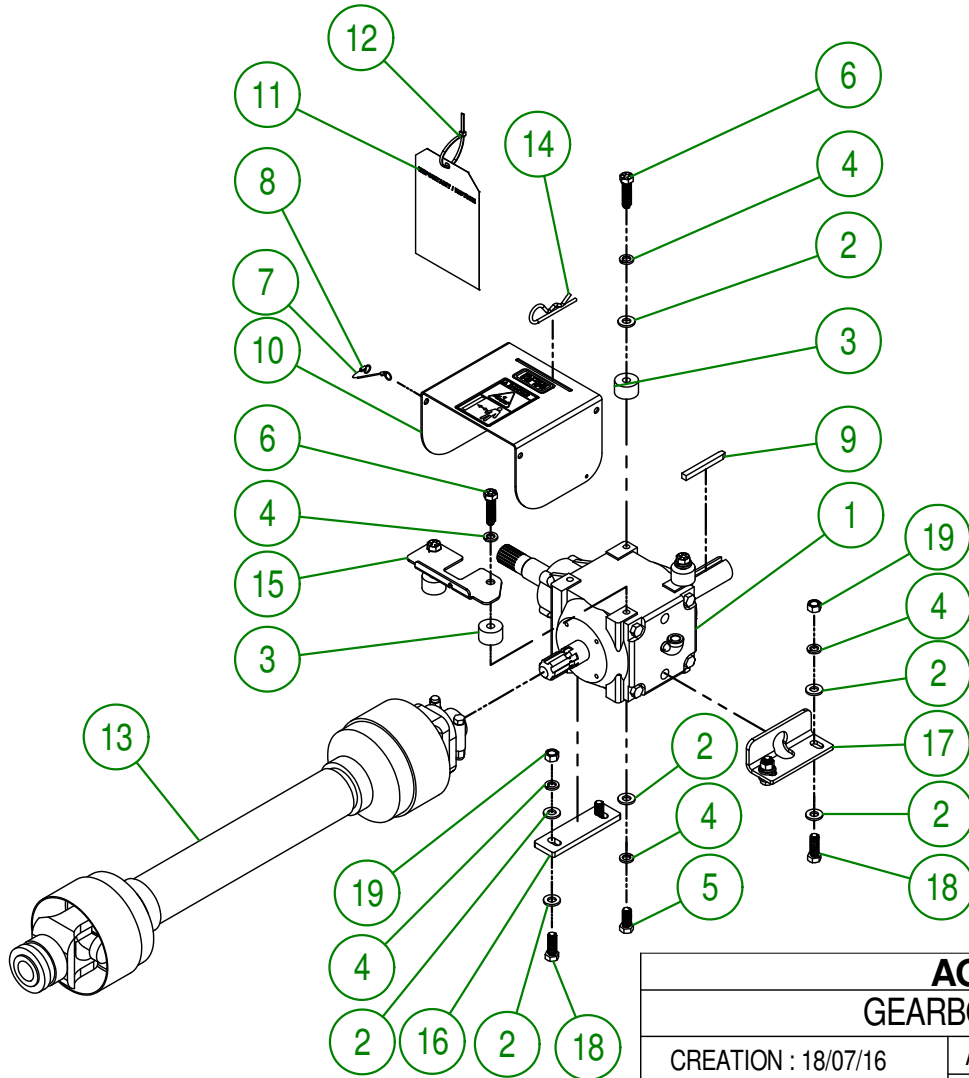

AGRIMETAL
GEARBOX GROUPING

CREATION : 18/07/16
 REVISION : 11/04/19

ASSEMBLY : **80-57-0430**
 AUTHOR : Dessin2 | Page 13 de 23

82-57-1926

#	PART #	Qty	TITLE
1	82-50-0051	1	IMPELLER
2	NC01-37-0121	2	HEX. BOLT GR8 ZINC 3/8-24 X 2 3/4" LG
3	NC01-94-0011	2	LOCK NUT 3/8-24
4	80-04-0185	1	WASHER
5	NC01-25-0395	1	HEX. BOLT GR5 ZINC 5/8-11 X 1 3/4" LG
6	NC02-32-0016	1	LOCK WASHER ZINC 5/8"

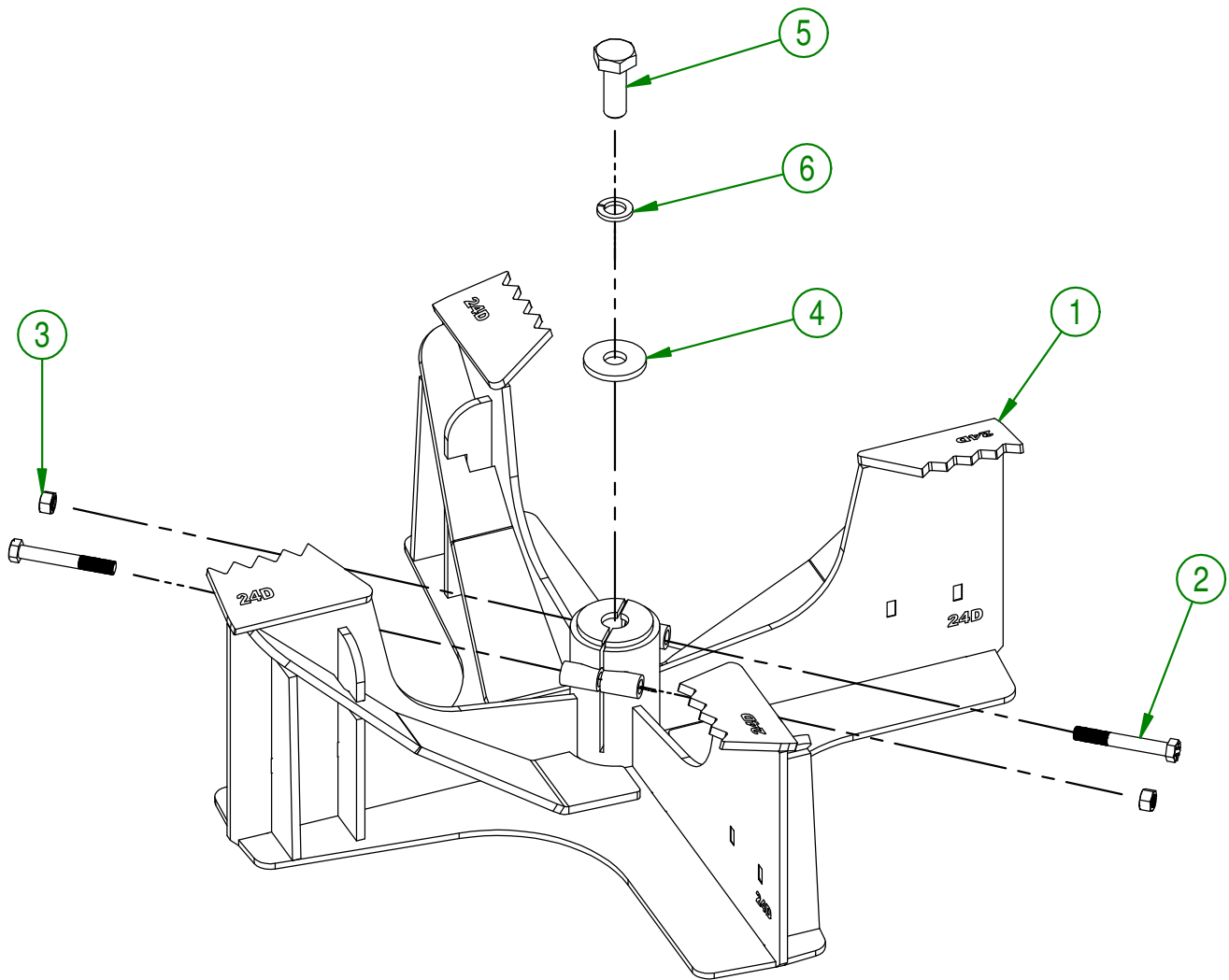

AGRIMETAL
IMPELLER GROUP

CREATION : 16/04/18
 REVISION : 25/06/20

ASSEMBLY : **82-57-1926**

AUTHOR : F.HÉLIE | Page 14 de 23

#	PART #	Qty	TITLE
1	82-50-0110	1	LEFT SNOW GUARD
2	82-50-0113	1	RIGHT SNOW GUARD
3	NC02-32-0014	6	LOCK WASHER ZINC 1/2"
4	NC01-25-0247	6	HEX. BOLT GR5 ZINC 1/2-13 X 1" LG

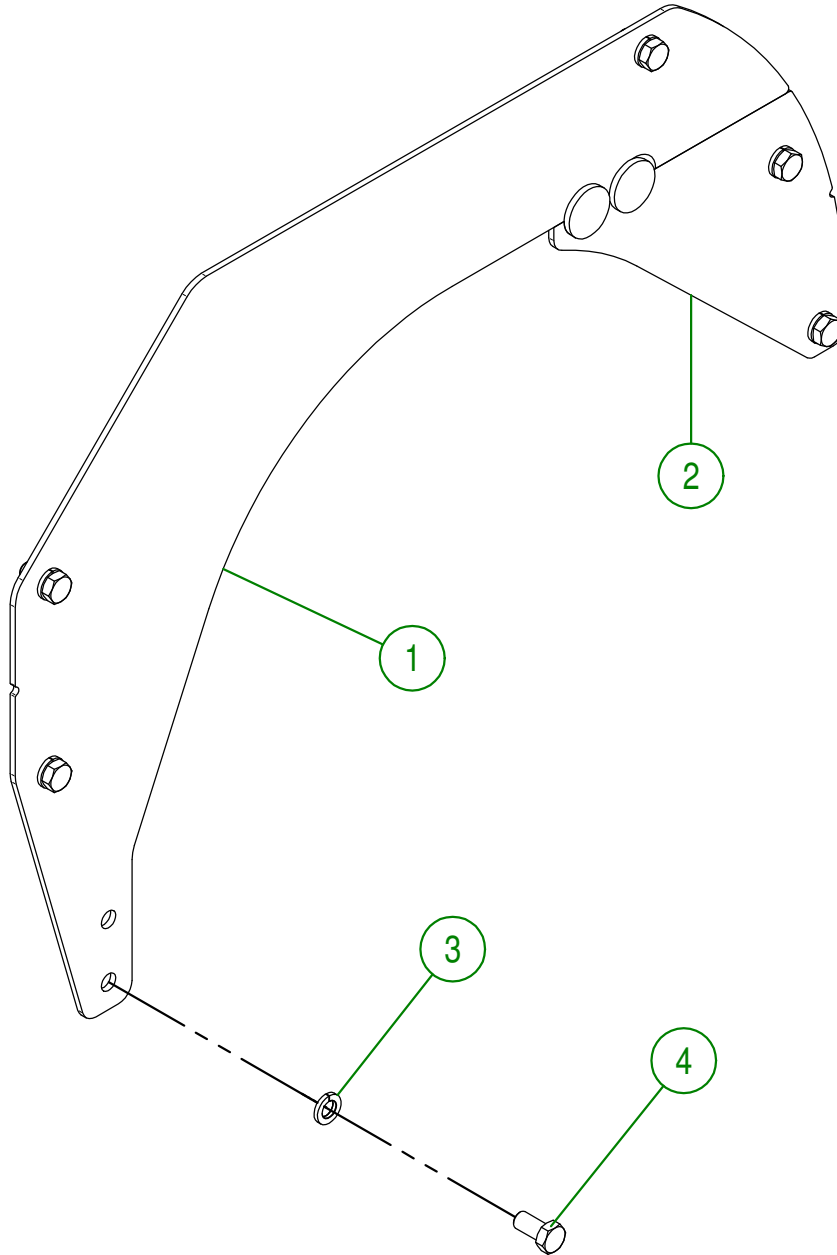

AGRIMETAL	
SNOW GUARD GROUP	
CREATION : 20/07/16	ASSEMBLY : 82-57-1920
REVISION : 10/04/18	AUTHOR : J. HOULE Page 15 de 23

#	PART #	Qty	TITLE
1	NC14-75-0160	2	FLANGE BEARING UCF207-20 1/4" ID
2	82-50-1080	1	SPIRAL
3	NC02-25-0011	8	WASHER SAE ZINC 17/32 ID
4	NC01-17-0250	8	HEX. BOLT GR2 ZINC 1/2-13 X 3/4"
5	NC02-32-0014	8	LOCK WASHER ZINC 1/2"
6	NC02-07-0020	8	HEX. NUT ZINC 1/2-13
8	NC14-55-0294	1	60A32H SPROCKET
9	NC01-29-0115	4	HEX. BOLT GR5 ZINC 3/8-24 X 1/4"
10	NC01-94-0011	4	LOCK NUT ZINC 3/8-24
11	82-51-0086	1	SHAFT OF THE SPIRAL
12	82-51-0091	1	SHAFT OF THE SPIRAL (SPROCKET)

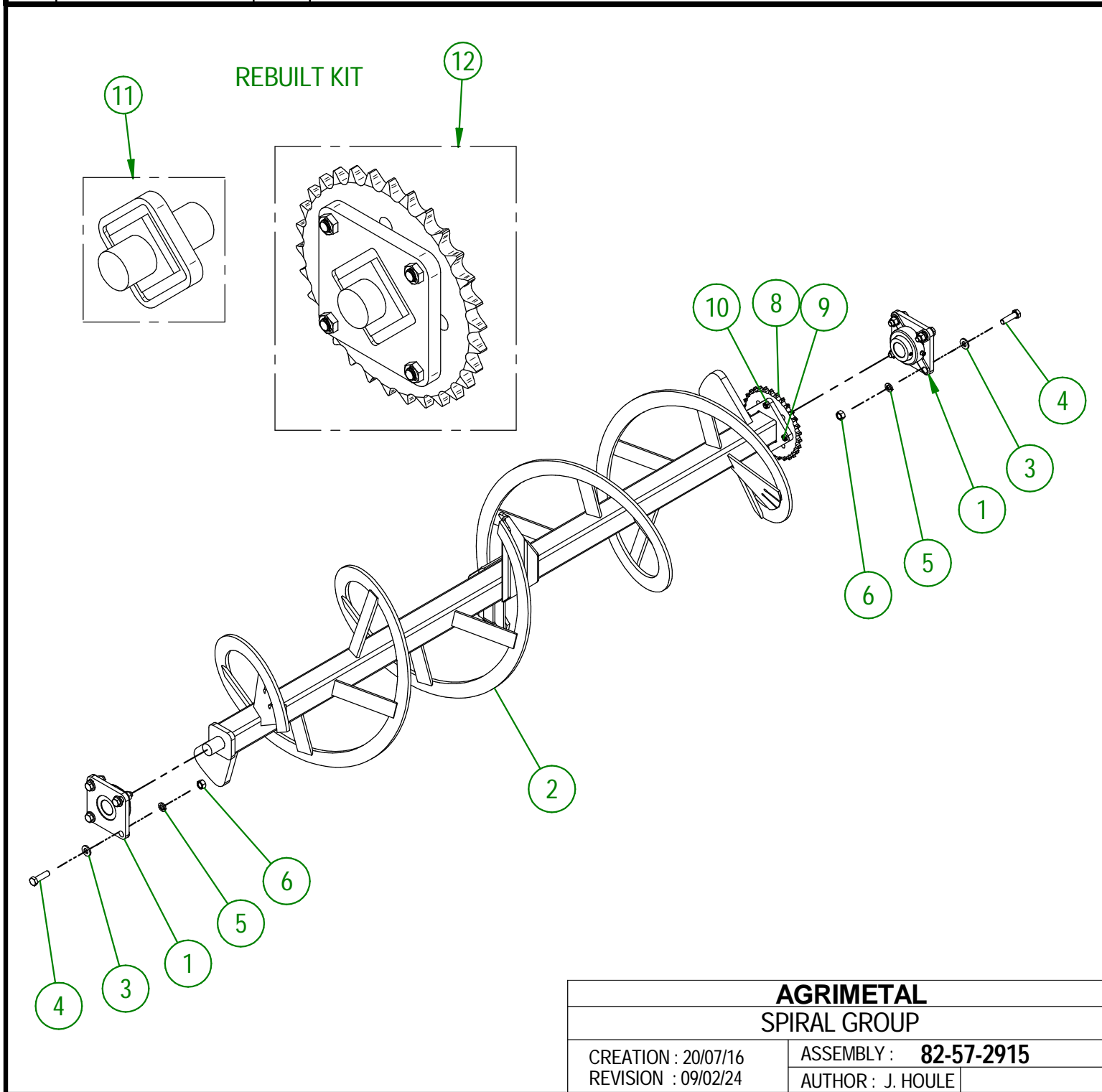

AGRIMETAL	
SPIRAL GROUP	
CREATION : 20/07/16	ASSEMBLY : 82-57-2915
REVISION : 09/02/24	AUTHOR : J. HOULE

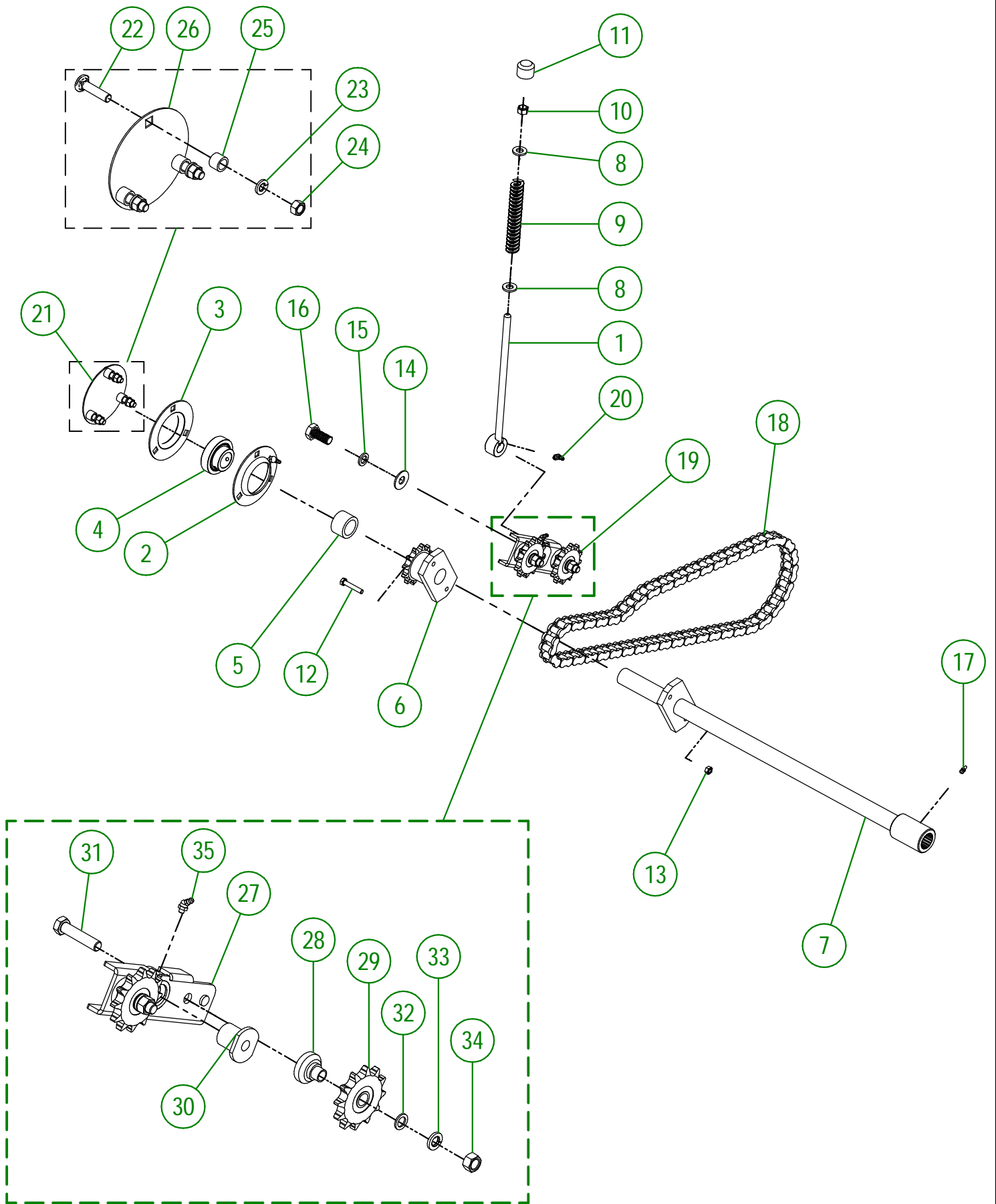

AGRIMETAL	
SPIRAL DRIVE TRAIN GROUP	
CREATION : 20/07/16	ASSEMBLY : 82-57-2935
REVISION : 13/04/23	AUTHOR : Dessin2

82-57-2935

#	PART #	Qty	TITLE
1	80-50-0040	1	THREADED ROD
2	80-55-0030	1	PRESSED STEEL FLANGE WITH GREASE FITTING
3	NC14-75-0093	1	PRESSED STEEL FLANGE
4	NC14-75-0164	1	SB207-20 BEARING
5	80-24-0000	1	SPIRAL DRIVE TRAIN BUSHING
6	NC14-55-0293	1	60BI2H SPROCKET
7	82-50-1065	1	SPIRAL DRIVE TRAIN
8	NC02-25-0011	2	WASHER SAE ZINC 17/32 ID
9	NC13-86-0054	1	BLUE SPRING 1/2" ID X 1" OD X 6" LG
10	NC01-96-0014	1	NYLON-INSERT LOCKNUT ZINC 1/2-13
11	80-42-0110	1	THREADED ROD CAP
12	NC01-17-0063	1	CAP SCREW GR2 NC ZINC 5/16-18 X 1 3/4"
13	NC01-93-0010	1	LOCK NUT ZINC 5/16-18
14	NC02-22-0013	1	WASHER ZINC 5/8 ID X 1 1/2 OD
15	NC02-32-0016	1	LOCK WASHER ZINC 5/8"
16	NC01-21-0394	1	HEX. BOLT GR2 ZINC 5/8-18 X 1 1/2" LG
17	NC01-69-0785	1	STRAIGHT GREASE FITTING 1/4-28
18	82-37-1005	1	#60 HD CHAIN
19	80-55-0025	1	CHAIN TENSIONER GROUP
20	NC01-69-0787	1	GREASE FITTING STRAIGHT 1/4-28 X 90
21	82-57-2950	1	BEARING GUARD GROUP.

82-57-2950

#	PART #	Qty	TITLE
22	NC01-04-0111	3	CARR. BOLT GR2 ZINC 3/8-16 X 1 1/2"
23	NC02-32-0012	3	LOCK WASHER ZINC 3/8"
24	NC02-07-0018	3	HEX. NUT ZINC 3/8-16
25	82-21-0000	3	BEARING BUSHING GUARD
26	82-01-7540	1	BEARING GUARD

80-55-0025

#	PART #	Qty	TITLE
27	80-50-0045	1	CHAIN TENSIONER
28	80-21-0020	2	CHAIN TENSIONER BUSHING (SPROCKET)
29	NC14-55-0295	2	SPROCKET 60A12H
30	80-13-2400	1	CHAIN TENSIONER BUSHING
31	NC01-29-0252	2	HEX. BOLT GR2 ZINC 1/2-20 X 2 1/4" LG
32	NC02-26-1100	2	WASHER SAE ZINC 17/32 ID X 13/16" OD
33	NC02-32-0014	2	LOCK WASHER ZINC 1/2"
34	NC02-10-0020	2	HEX. NUT ZINC 1/2-20
35	NC01-69-0786	1	GREASE FITTING 1/4-28 X 45

#	PART #	Qty	TITLE
1	82-50-0071	1	CHAIN GUARD
2	NC01-04-0107	4	CARR. BOLT GR2 ZINC 3/8-16 X 3/4"
3	NC02-14-0019	4	FLANGE NUT HEX. NC 3/8-16 GR. B

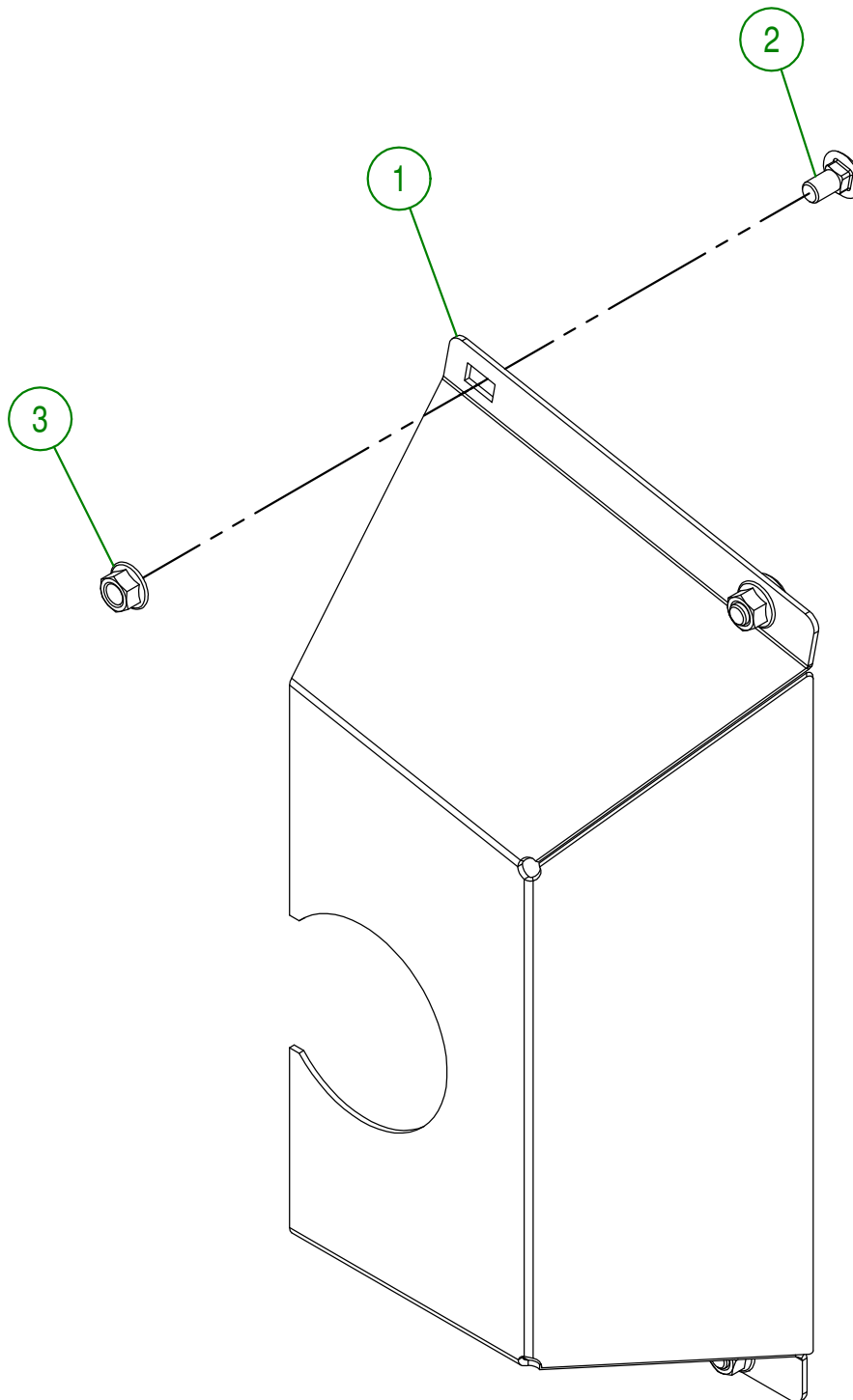

AGRIMETAL	
SPIRAL CHAIN GUARD GROUP	
CREATION : 20/07/16	ASSEMBLY : 82-57-1905
REVISION : 10/04/18	AUTHOR : J. HOULE Page 19 de 23

#	PART #	Qty	TITLE
1	01-01-2485	4	FLAT WASHER 14 GA X 13/16"OD X 25/64" ID
2	NC01-17-0114	2	HEX. BOLT GR2 ZINC 3/8-16 X 1"
3	NC01-96-0011	2	NYLON NUT 3/8-16
4	82-57-0036	1	CHAIN GUARD

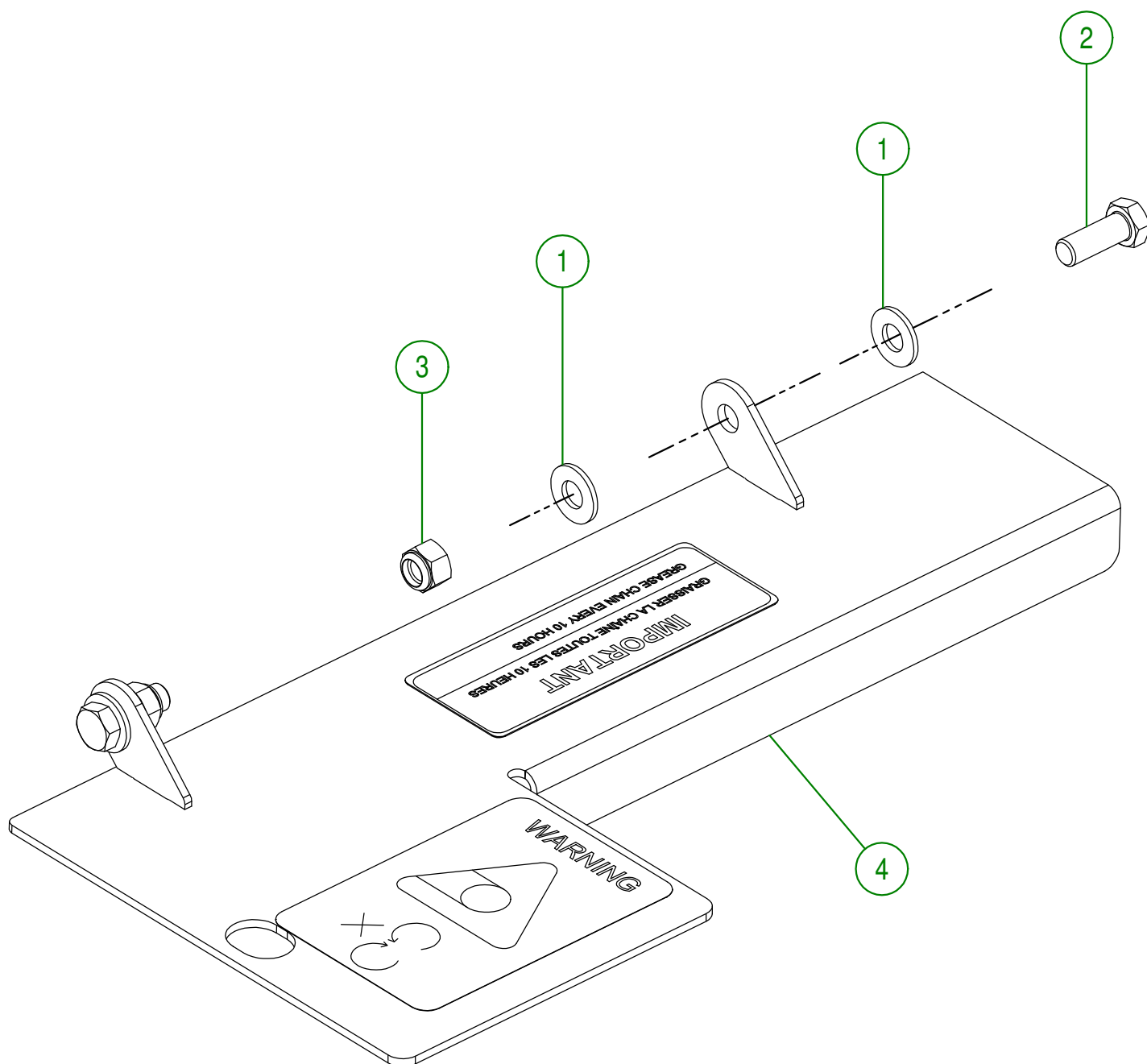

AGRIMETAL	
CHAIN GUARD GROUP	
CREATION : 20/07/16	ASSEMBLY : 82-57-1945
REVISION : 18/11/19	AUTHOR : J. HOULE Page 20 de 23

#	PART #	Qty	TITLE
1	NCI3-30-0237	1	PLASTIC TUBE FOR OPERATOR'S MANUAL
2	NC02-22-0008	2	WASHER ZINC 5/16"
3	NC01-17-0007	2	HEX. BOLT GR2 ZINC 1/4-20 X 1 1/4"
4	NC01-96-0009	2	NYLON-INSERT LOCKNUT ZINC 1/4-20
5	80-57-0030	1	SET OF 6 SHEAR BOLT WITH NUT
6	80-98-0522	1	ENGLISH OPERATOR'S MANUAL (MS26, 26-D, 24-D)

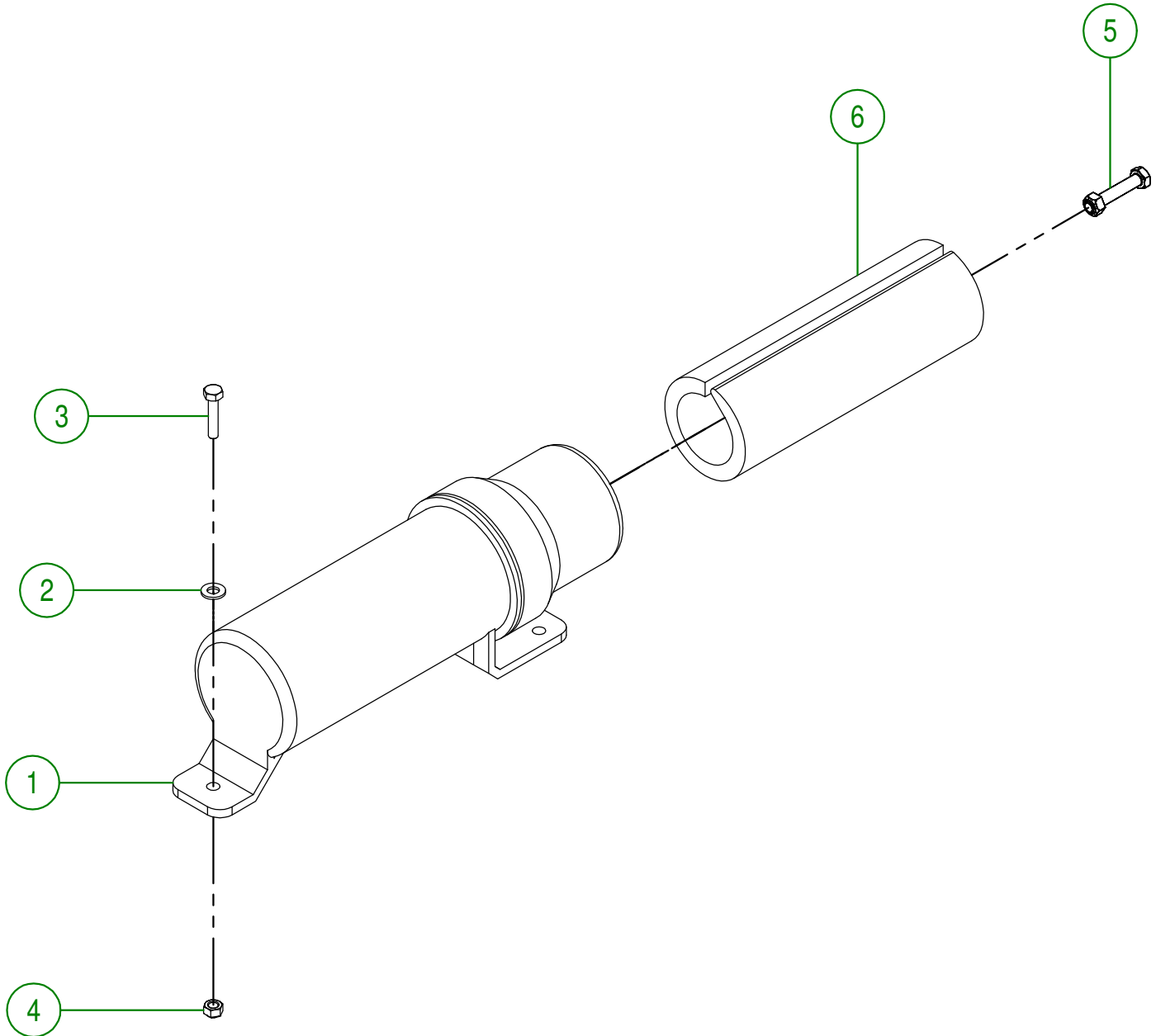
**AGRIMETAL****OPERATOR'S MANUAL TUBE GROUP**

CREATION : 18/07/16
 REVISION : 08/05/18

ASSEMBLY : **80-57-0400**

AUTHOR : J. HOULE | Page 21 de 23

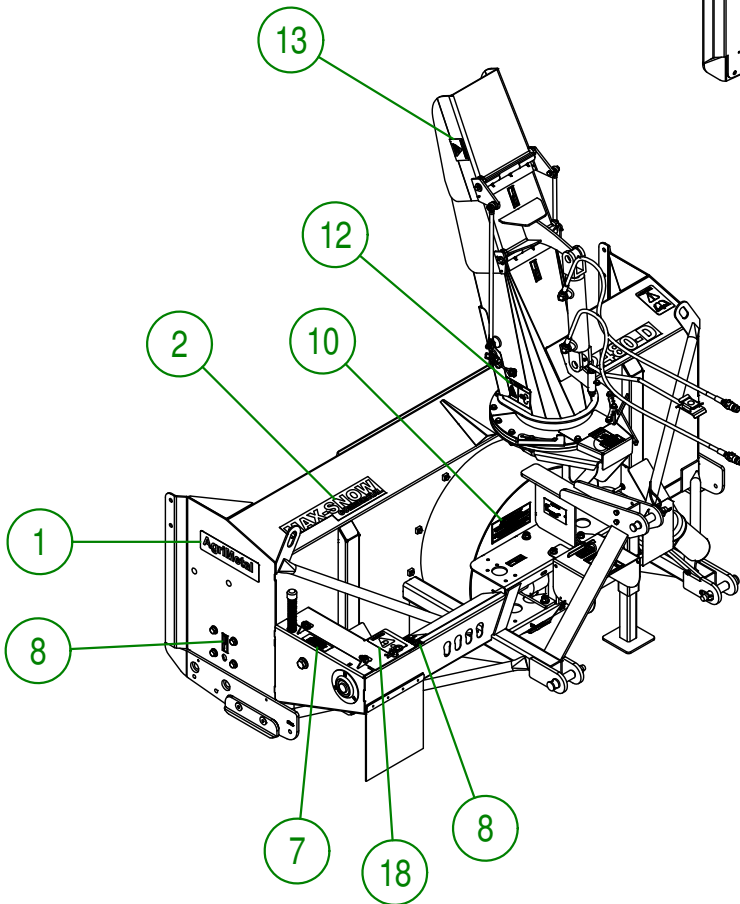
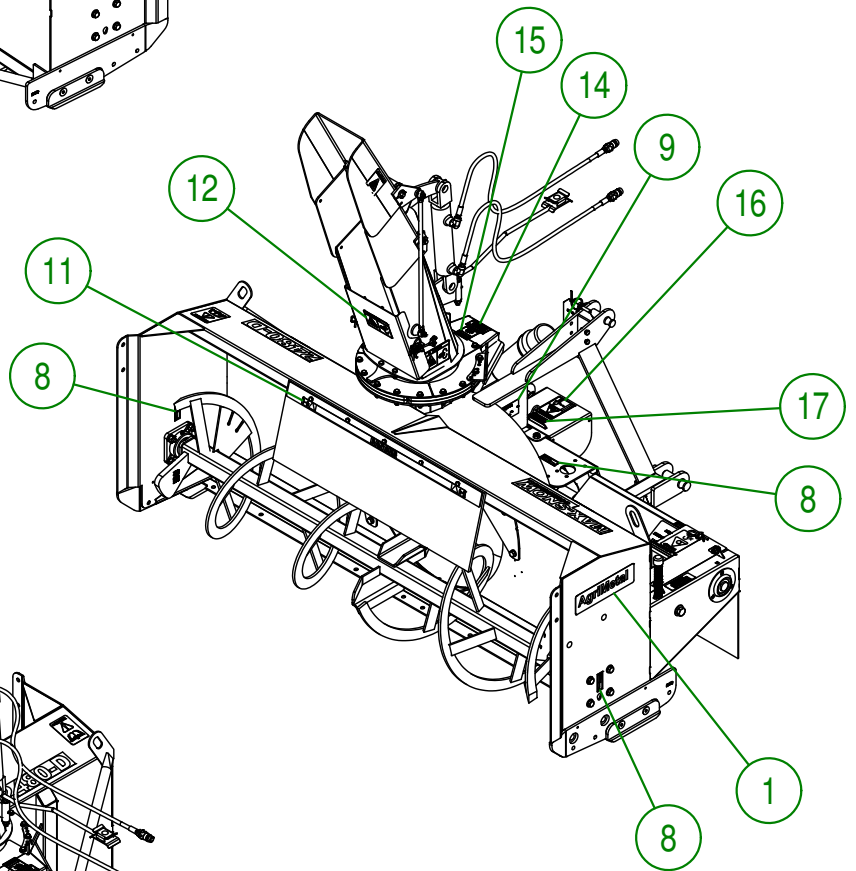
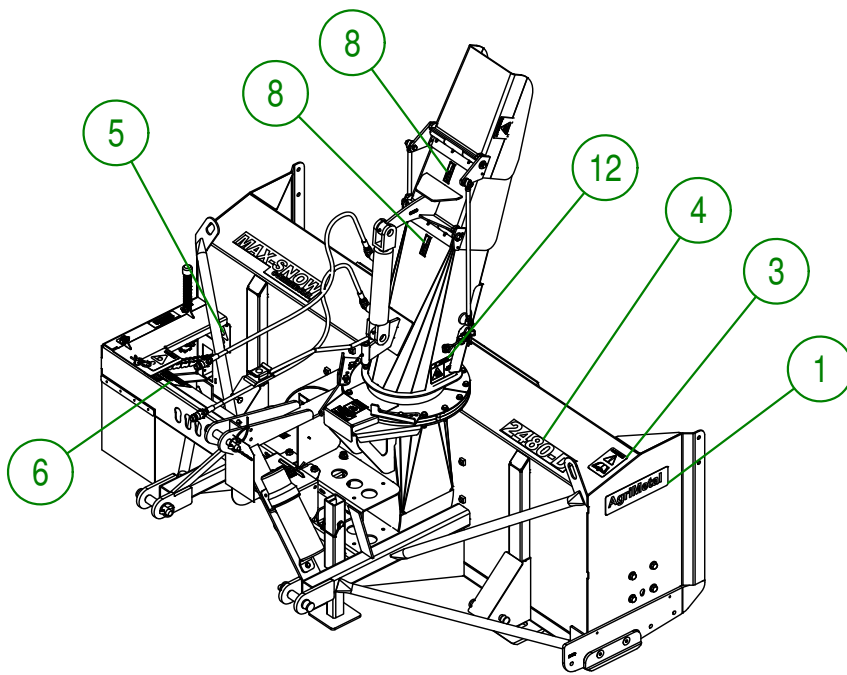

AGRIMETAL	
MS2480-D	
CREATION : 20/07/16	ASSEMBLY : 82-99-2500
REVISION : 16/04/19	AUTHOR : Dessin2 Page 22 de 23

#	PART #	QT	TITLE
1	NC13-33-0035	2	STICKER AGRIMETAL
2	NC13-33-0241	1	STICKER MAX-SNOW COMMERCIAL
3	NC13-33-0183	1	STICKER CAUTION OPERATION MANUAL
4	NC13-33-0273	1	STICKER 2480-D
5	NC13-33-0189	1	STICKER DANGER (PERSON AND CHAIN DRIVE)
6	NC13-33-0280	1	STICKER SHEAR BOLT
7	NC13-33-0104	1	STICKER IMPORTANT 4 INCHES 100 MM
8	NC13-33-0024	6	STICKER GREASE HERE
9	NC13-50-0086	1	SERIAL NUMBER PLATE
10	NC13-33-0317	1	STICKER GREASE DRIVE LINE TELESCOPIC SHAFT
11	NC13-33-0274	1	STICKER DANGER
12	NC13-33-0249	3	STICKER DANGER
13	NC13-33-0192	2	STICKER (PROJECTION RISK)
14	NC13-33-0327	1	STICKER END ROTATION ADJUSTMENT
15	NC13-33-0326	1	STICKER DANGER (HAND)
16	NC13-33-0187	1	STICKER DANGER (PTO AND PERSON)
17	NC13-33-0005	1	STICKER MAXIMUM 540 RPM
18	NC13-33-0283	1	STICKER DANGER (PERSON AND CHAIN DRIVE)