

AgriMetal

PART LIST

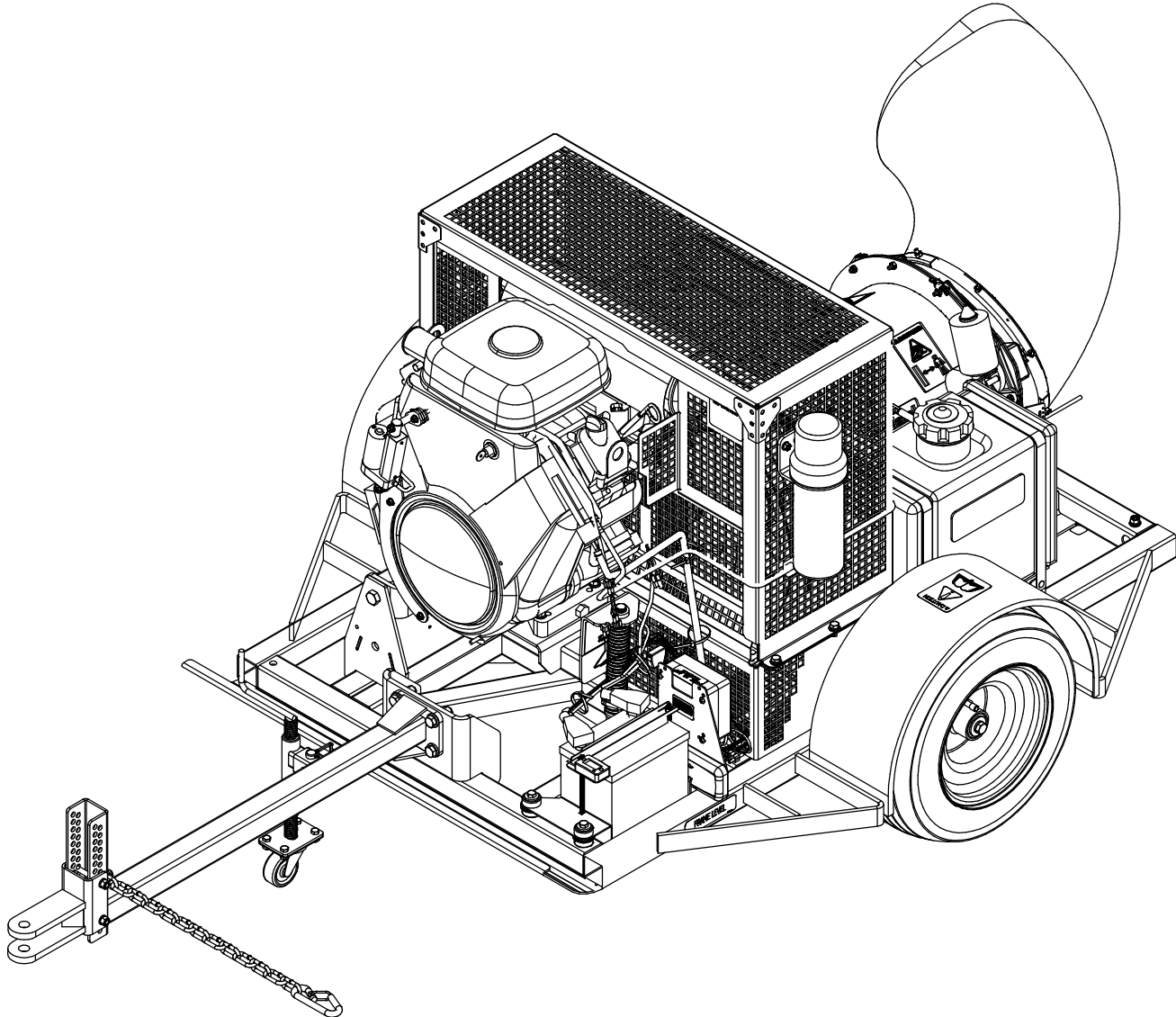

TURBINE BLOWER 350 IC

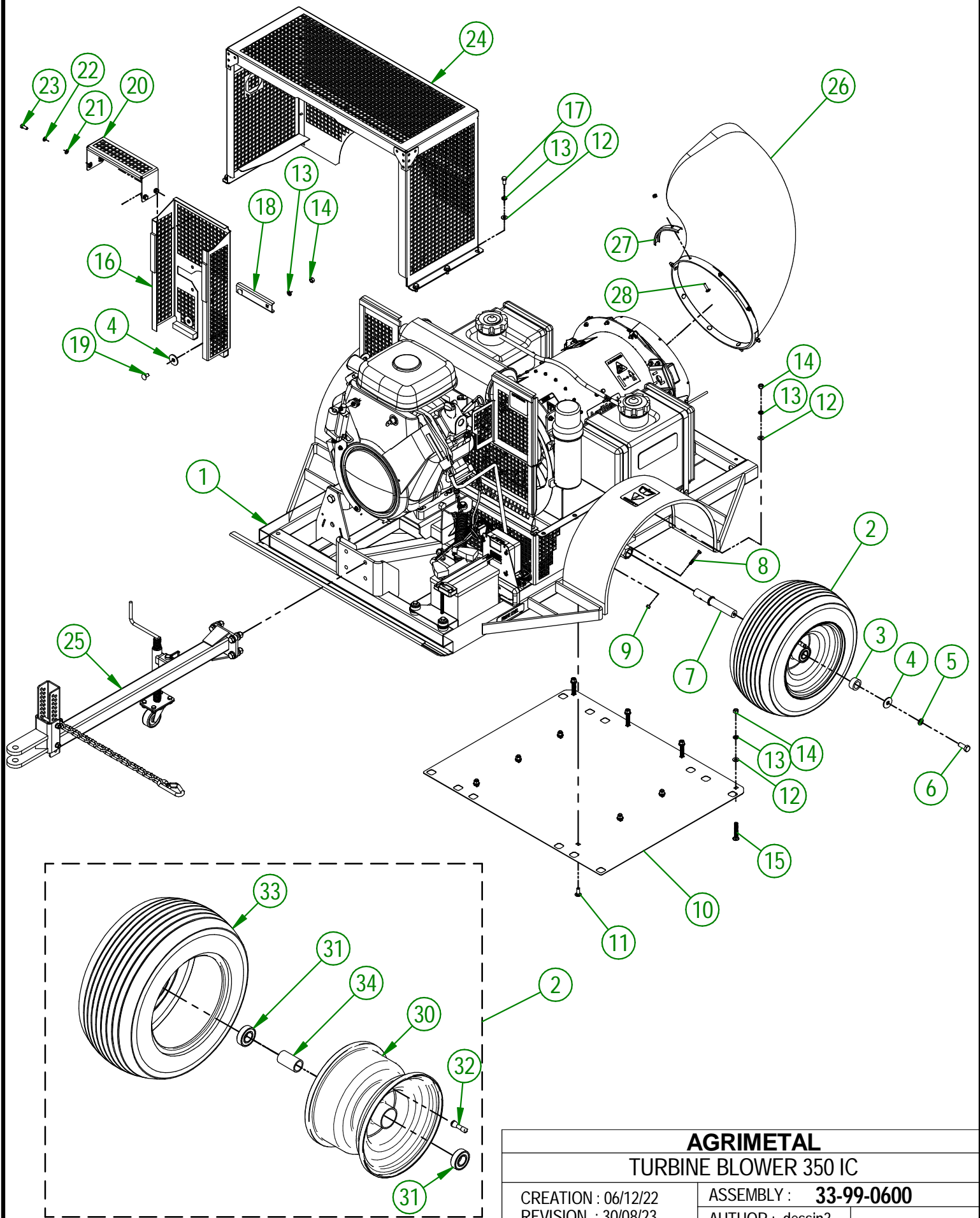

AGRIMETAL

TURBINE BLOWER 350 IC

CREATION : 06/12/22
 REVISION : 30/08/23

ASSEMBLY : **33-99-0600**
 AUTHOR : dessin3

33-99-0600

#	PART #	Qty	TITLE
1	33-57-0500	1	FRAME " STICKER INCLUDED"
2	33-55-0125	2	ASSEMBLY WHEEL 18X9.50-8 WITH BALL BEARING
3	33-21-0065	2	WHEEL BUSHING
4	01-01-1660	4	WASHER SPACER
5	NC02-32-0014	2	LOCK WASHER ZINC 1/2"
6	NC01-17-0248	2	HEX. BOLT GR2 ZINC 1/2-13 X 1 1/4"
7	33-13-0100	2	AXLE SHAFT
8	NC01-33-0010	2	GRADE 8 HEX HEAD SCREW 1/4-20 X 2" LG.
9	NC01-93-0001	2	HEX. NUT NC ZINC 1/4-20
10	33-01-3071	1	SCRATCH PLATE
11	NC01-04-0109	6	CARR. BOLT GR2 ZINC 3/8-16 X 1"
12	01-01-2485	16	FLAT WASHER 14 GA X 13/16"OD X 25/64" ID
13	NC02-32-0012	18	LOCK WASHER ZINC 3/8"
14	NC02-07-0018	12	HEX. NUT ZINC 3/8-16
15	NC01-04-0115	4	CARR. BOLT GR2 ZINC 3/8-16 X 2 1/2"
16	33-55-2610	1	BELT GUARD (RIBBON INCLUDED)
17	NC01-17-0112	6	HEX. BOLT GR2 ZINC 3/8-16 X 3/4"
18	33-03-4805	1	BELT GUARD REINFORCING
19	NC01-04-0107	2	CARR. BOLT GR2 ZINC 3/8-16 X 3/4"
20	33-50-0100	1	STRAP GUARD
21	NC02-22-0008	4	WASHER ZINC 5/16"
22	NC02-32-0011	4	LOCK WASHER ZINC 5/16"
23	NC01-17-0058	4	HEX. BOLT GR2 ZINC 5/16-18 X 3/4" LG
24	33-55-0655	1	GRILL (TB350 IC)
25	33-55-0540	1	ASSEMBLY HITCH
26	33-42-0005	1	90° PLASTIC ELBOW
27	33-01-2480	4	DUCT CLAMP
28	NC01-04-0005	8	CARR. BOLT GR2 ZINC 1/4-20 X 1"
29	NC01-96-0009	8	NYLON-INSERT LOCKNUT ZINC 1/4-20

33-55-0125

#	PART #	Qty	TITLE
30	NC14-70-0320	1	RIM FOR NC14-70-0317
31	NC14-55-0330	2	6205-2RSI BEARING
32	NC14-70-0322	1	VALVE FOR NC14-70-0317
33	NC14-70-0319	1	WHEEL 18X9.50-8 (TURBINE)
34	33-10-0015	1	INSIDE WHEEL SPACER

#	PART #	Qty	TITLE
1	NC13-68-0025	2	T UNION 1/4" DI
2	NC13-65-0065	1	BARBED HOSE REDUCER 1/4" X 3/16"
3	33-46-0605	1	GAS HOSE VAPOR 1/2" DIA. X 1/4" DI X 2 1/4" EPA
4	33-46-0600	1	GAS HOSE VAPOR 1/2" DIA. X 1/4" DI X 19 1/4" EPA
5	33-46-0612	1	VAPOR GAS LINE EPA 1/2" DIA. X 1/4" I.D. X 44" LG
6	NC13-80-0248	2	GAS TANK
7	NC13-80-0266	2	1/4" ON-OFF GAS VALVE
8	NC13-80-0265	2	GROMMET VITRON #468661
9	NC13-80-0247	2	GAS CAP
10	33-01-1500	4	GAS TANK STRAP SUPPORT
11	33-01-3060	4	GAS TANK STRAP
12	NC01-04-0002	4	CARR. BOLT GR2 ZINC 1/4-20 X 5/8"
13	NC01-96-0009	8	NYLON-INSERT LOCKNUT ZINC 1/4-20
14	33-46-0536	1	GAS HOSE 1/4" ID X 1/2" OD X 6"
15	NC01-65-0201	6	SPRING -GRIP HOSE CLAMPS 1/2" O.D
16	33-46-0537	1	GAS HOSE 1/4" ID X 1/2" OD X 32"
17	33-46-0665	1	GAS HOSE 1/4" ID X 1/2" OD X 39"

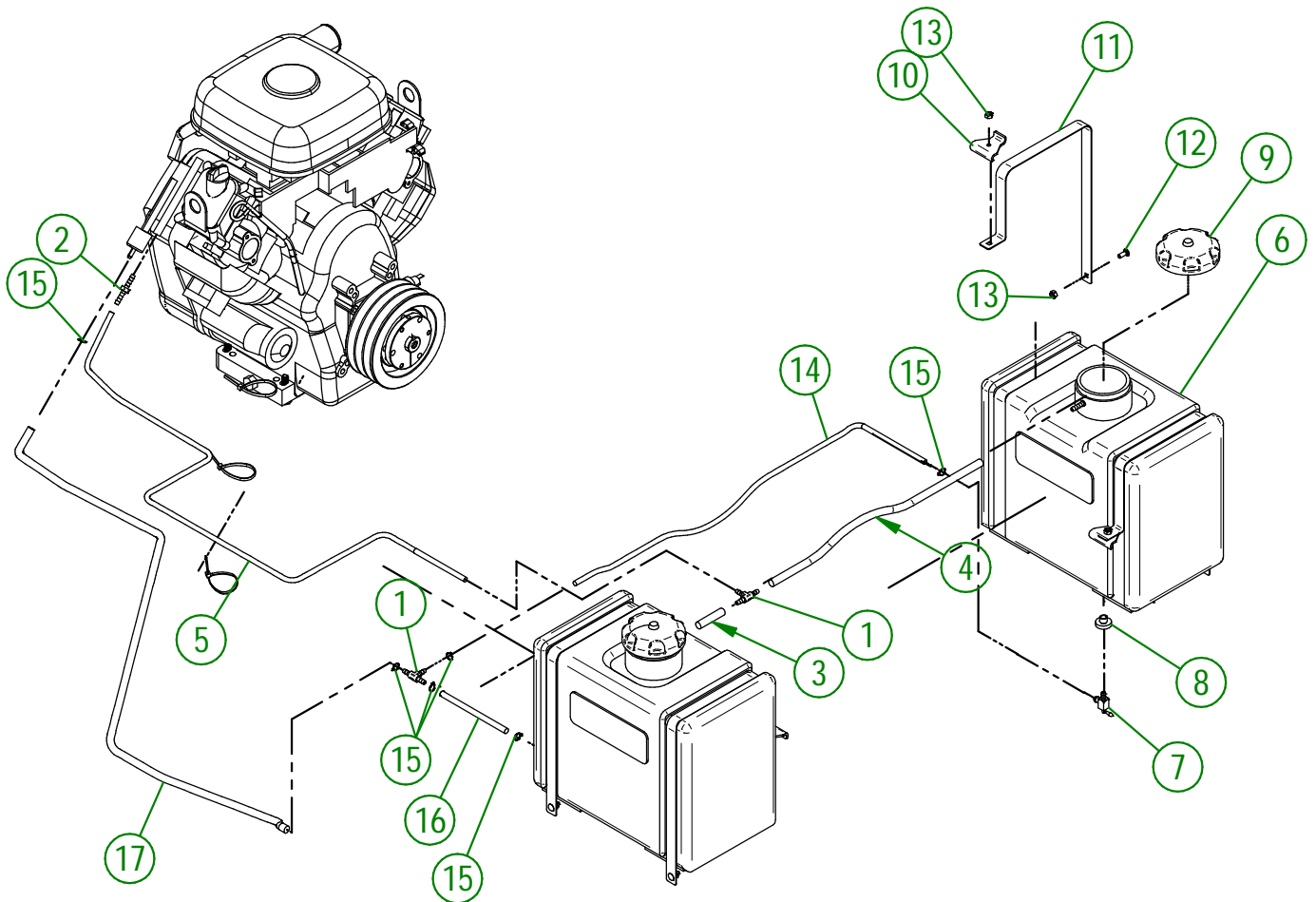
**AGRIMETAL****TURBINE BLOWER 350 IC**

CREATION : 03/10/22
 REVISION : 28/11/23

ASSEMBLY : **33-99-0600**
 AUTHOR : D. CHASSÉ

#	PART #	Qty	TITLE
1	NC13-15-0055	2	INSULATING ROLLED COLLAR 7/16"ID X 15/16"OD X 5/16"T
2	33-22-2240	1	WIRE PROTECTOR
3	NC02-42-0096	4	PHILLIPS SCREW ZINC #14 X 5/8"
4	NC13-25-0370	1	ELECTRIC BOX TB 380
5	NC13-25-0375	1	67" NEW BOX WIRE
6	NC13-25-0019	11	BLACK TIE RAP
7	NC13-25-0251	2	MICRO SWITCH BODY
8	NC13-25-0252	2	MICRO SWITCH HEAD
9	NC13-25-0253	2	MICRO SWITCH ROD ADAPTOR
10	NC13-25-0012	2	CONNECTOR "SKINTIGHT" (NYLON) 1/2 NPT X 0.200-0.470"
11	NC02-40-0081	4	SCREW ZINC 10-24 X 5/8"
12	NC01-96-0006	4	NYLON NUT ZINC 3/16
13	33-55-0515	1	18 GA ELECTRIC WIRE 600V (MICRO SWITCH) ASSY.
14	NC13-25-0233	2	VINYLE PROTECTOR COLLAR
15	33-57-0076	1	REMOTE CONTROL GROUP.

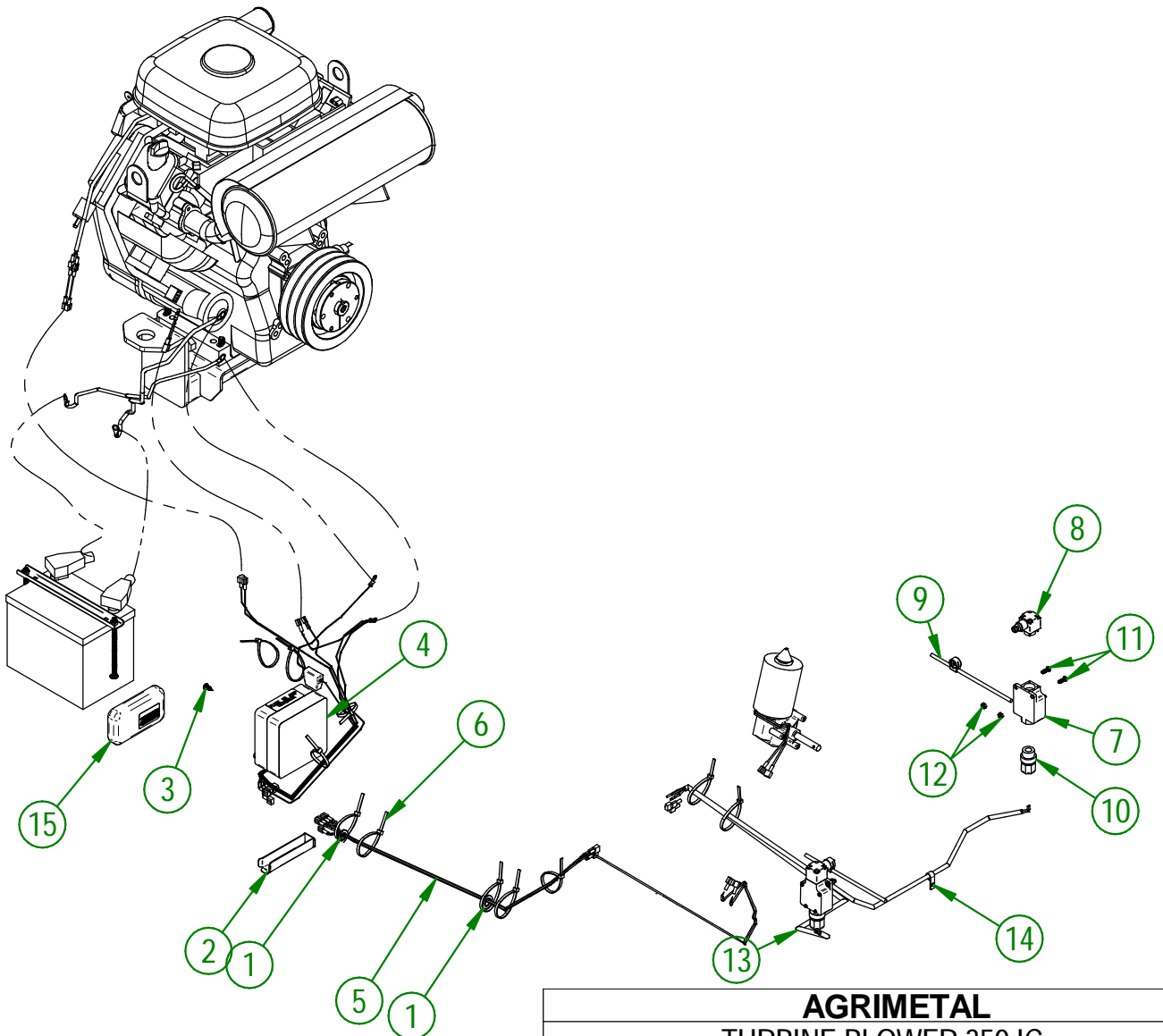
**AGRIMETAL****TURBINE BLOWER 350 IC**

CREATION : 03/10/22
 REVISION : 13/02/24

ASSEMBLY : **33-99-0600**
 AUTHOR : D. CHASSÉ

TURBINE BLOWER 240 IC
TURBINE BLOWER 270 IC

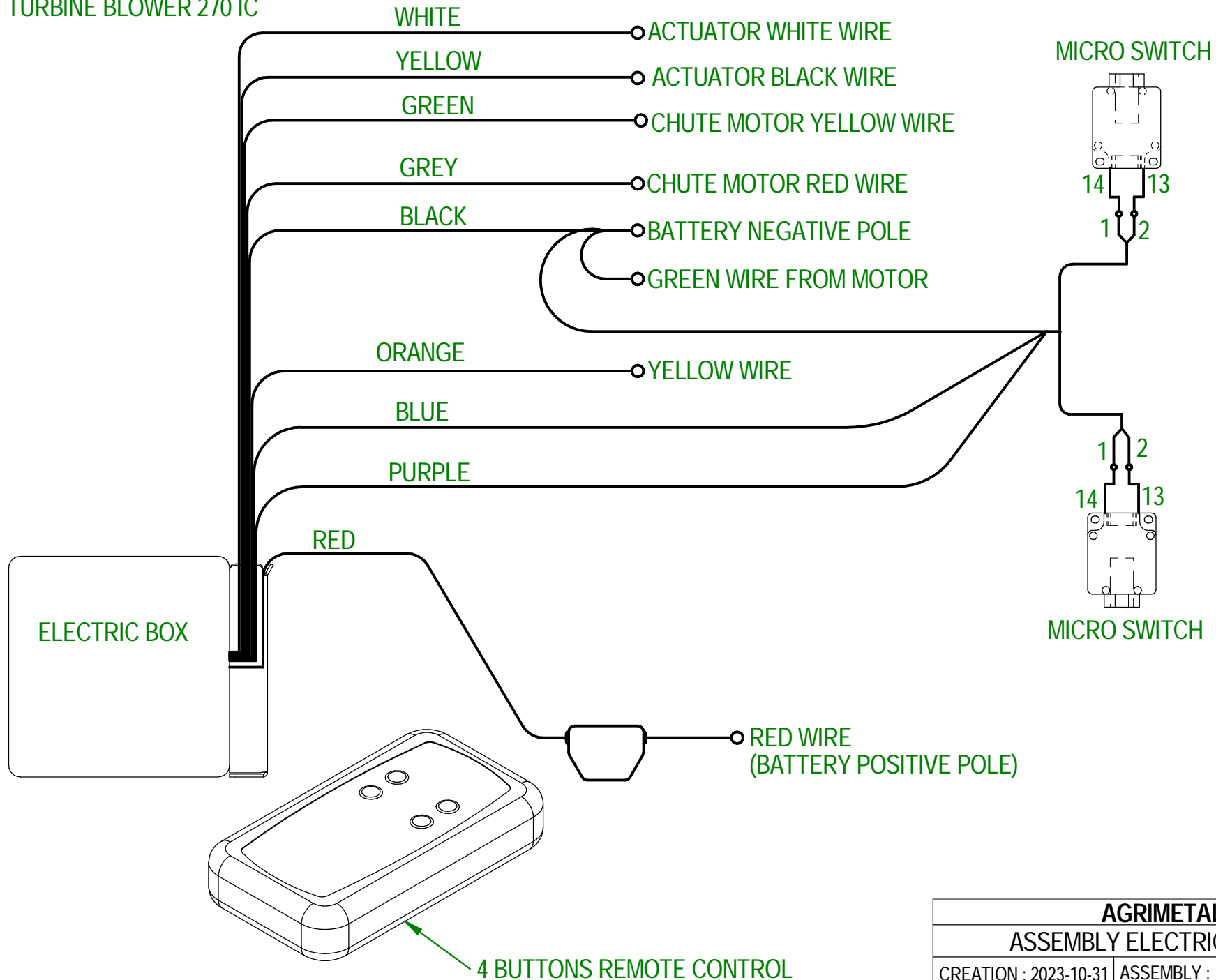

AGRIMETAL	
ASSEMBLY ELECTRIC CONTROL	
CREATION : 2023-10-31	ASSEMBLY : 33-57-0506
REVISION : 2023-11-07	AUTHOR : D. CHASSÉ

#	PART #	Qty	TITLE
1	33-50-0510	1	WELD ASSEMBLY HITCH BAR
2	33-50-0055	1	WELD ASSEMBLY HAND
3	33-55-0595	1	ASSEMBLY LEG
4	NC01-17-0123	2	HEX. BOLT GR2 ZINC 3/8-16
5	NC02-32-0012	2	LOCK WASHER ZINC 3/8"
6	NC02-07-0018	2	HEX. NUT ZINC 3/8-16
7	NC01-17-0116	1	HEX. BOLT GR2 ZINC 3/8-16 X 1 1/2"
8	21-01-0950	3	FLAT WASHER IOGA 1.005" DIA X 25/64"
9	NC01-96-0011	1	NYLON NUT 3/8-16
10	NC01-37-0250	4	HEX. BOLT GR8 ZINC 1/2-20 X 1 3/4"
11	01-01-0925	8	WASHER
12	NC02-32-0014	4	LOCK WASHER ZINC 1/2"
13	NC02-10-0020	4	HEX. NUT ZINC 1/2-20
14	NC01-69-1306	1	LOCKING PIN 3/8" X 2 1/2" LG
15	55-41-0000	1	SAFETY CHAIN

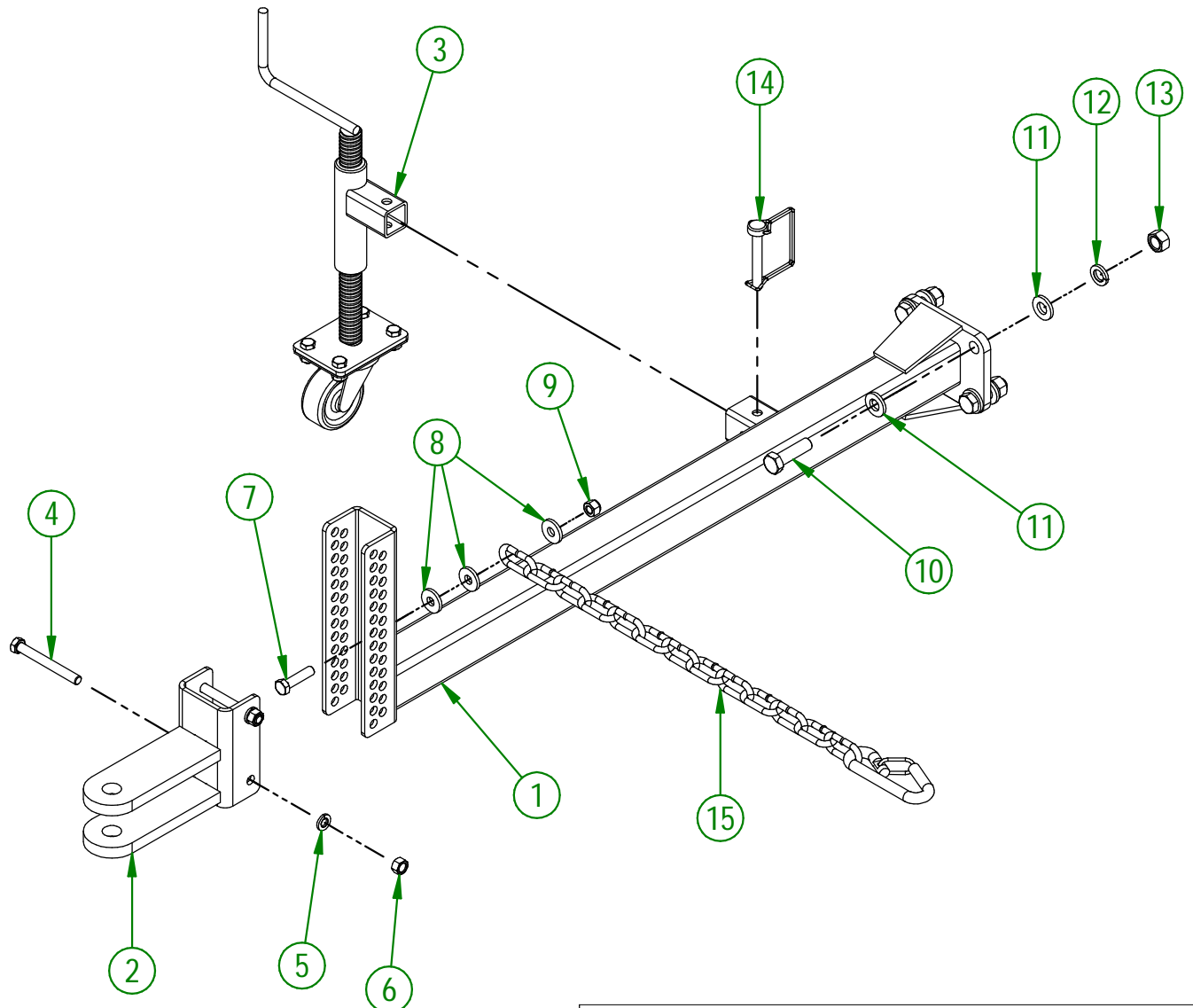

AGRIMETAL
ASSEMBLY HITCH

CREATION : 12/10/17
REVISION : 24/02/22

ASSEMBLY : **33-55-0540**
AUTHOR : J.KABWE

#	PART #	Qty	TITLE
1	33-50-0576	1	WELD ASSEMBLY LEG
2	NC14-70-0323	1	CASTER 1" X 2 1/4"
3	NC01-17-0058	4	HEX. BOLT GR2 ZINC 5/16-18 X 3/4"
4	NC02-32-0011	4	LOCK WASHER ZINC 5/16"
5	NC02-07-0017	4	HEX. NUT 5/16-18

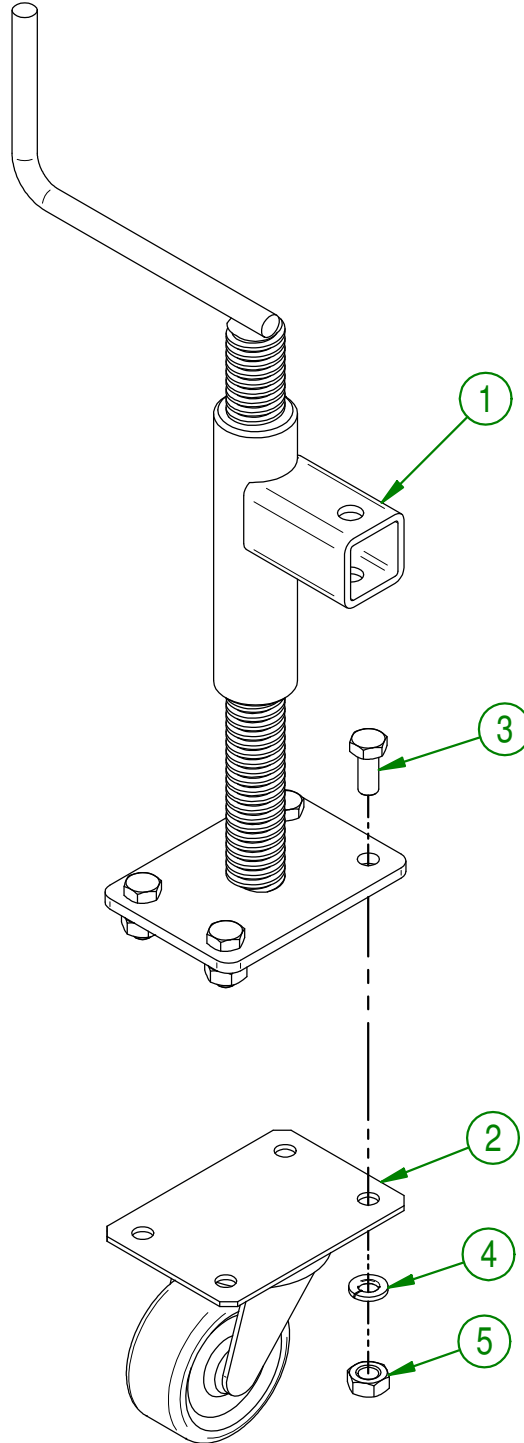

AGRIMETAL	
ASSEMBLY LEG	
CREATION : 13/11/17	ASSEMBLY : 33-55-0595
REVISION : 24/01/18	AUTHOR : J.KABWE Page 8 de 21

#	PART #	Qty	TITLE
1	33-50-0505	1	ENGINE BASE
2	NC01-17-0396	2	HEX. BOLT GR2 ZINC 5/8-11 X 2"
3	NC02-22-0014	2	WASHER ZINC 11/16 ID X 1 3/4 OD
4	NC02-32-0016	2	LOCK WASHER ZINC 5/8"
5	NC02-07-0022	2	HEX. NUT ZINC 5/8-11
6	33-13-0005	2	ENGINE BASE BUSHING

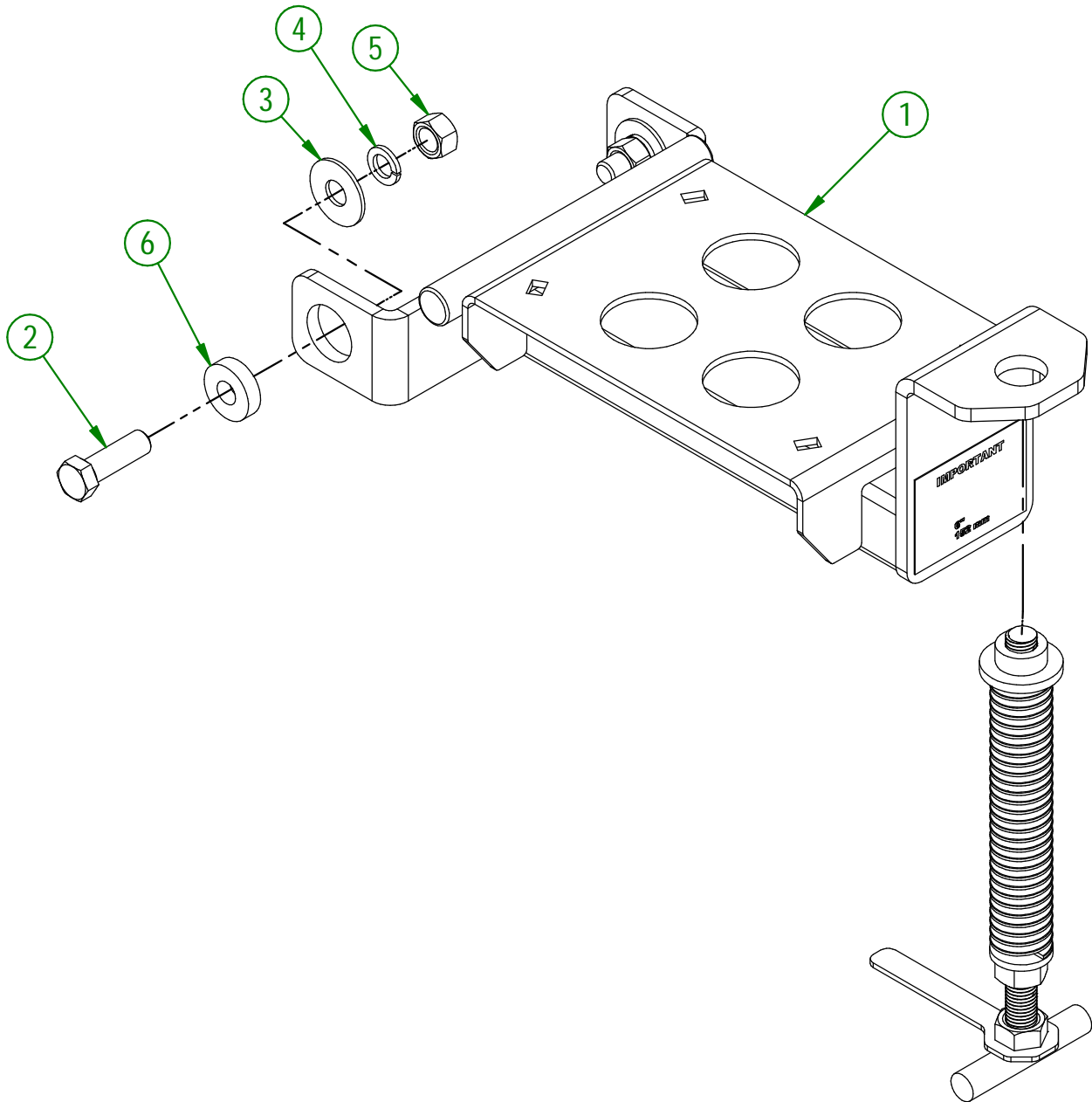

AGRIMETAL	
ENGINE BASE GROUP.	
CREATION : 14/11/17	ASSEMBLY : 33-57-0585
REVISION : 26/09/23	AUTHOR : J.KABWE

#	PART #	Qty	TITLE
1	33-50-0570	1	BELT TENSION
2	33-01-0975	1	TENSIONNER KEY
3	NC02-07-0023	1	HEX. NUT ZINC 3/4-10
4	22-04-6805	1	FLAT WASHER BEARING BASE
5	NC13-86-0083	1	BLUE SPRING 1/2" ID X 1" OD X 4"
6	33-42-0110	1	TENSIONNER GUIDE

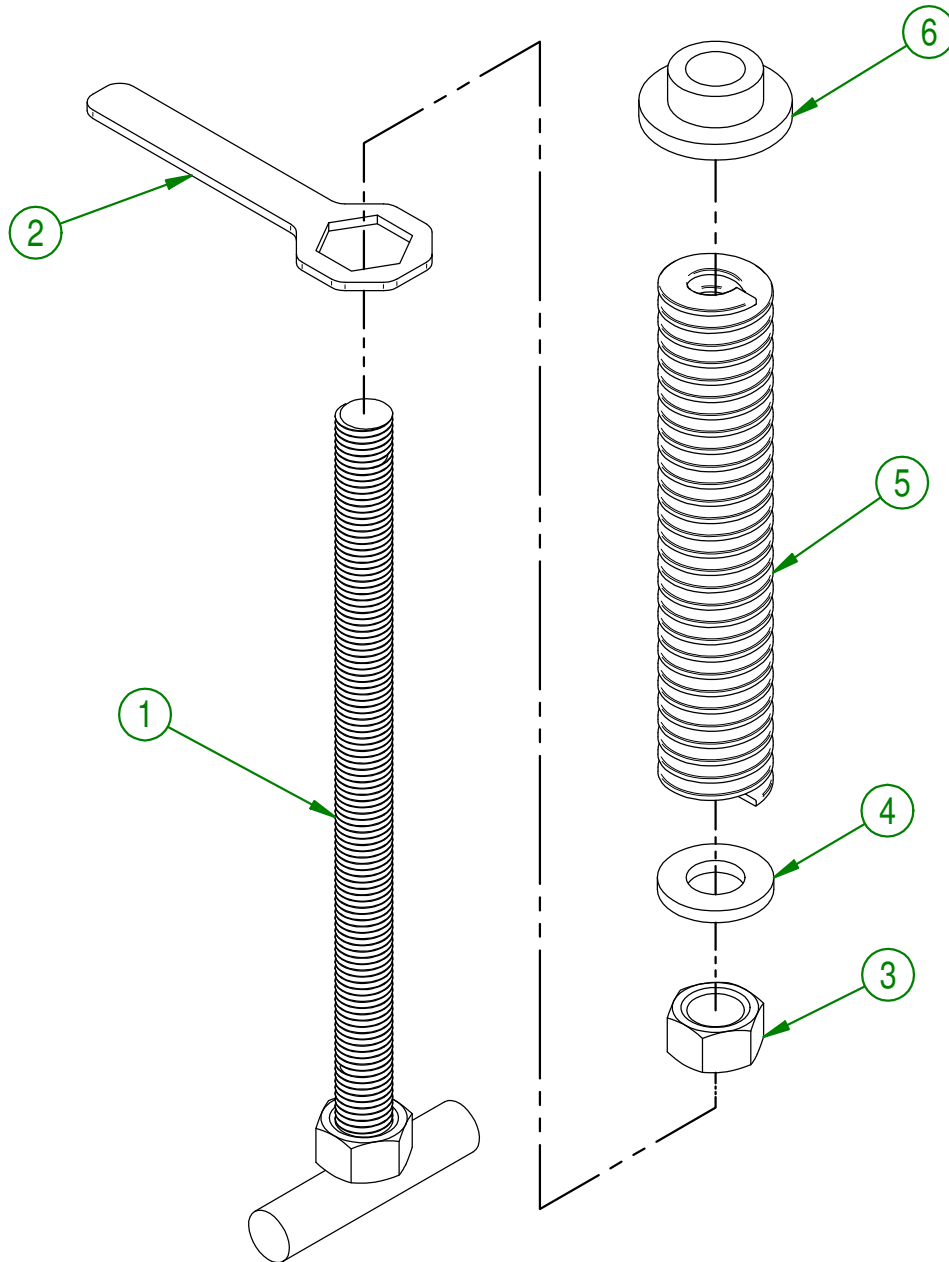

AGRIMETAL	
ASSEMBLY BELT TENSION	
CREATION : 09/11/17	ASSEMBLY : 33-57-0586
REVISION : 08/01/18	AUTHOR : J.KABWE Page 10 de 21

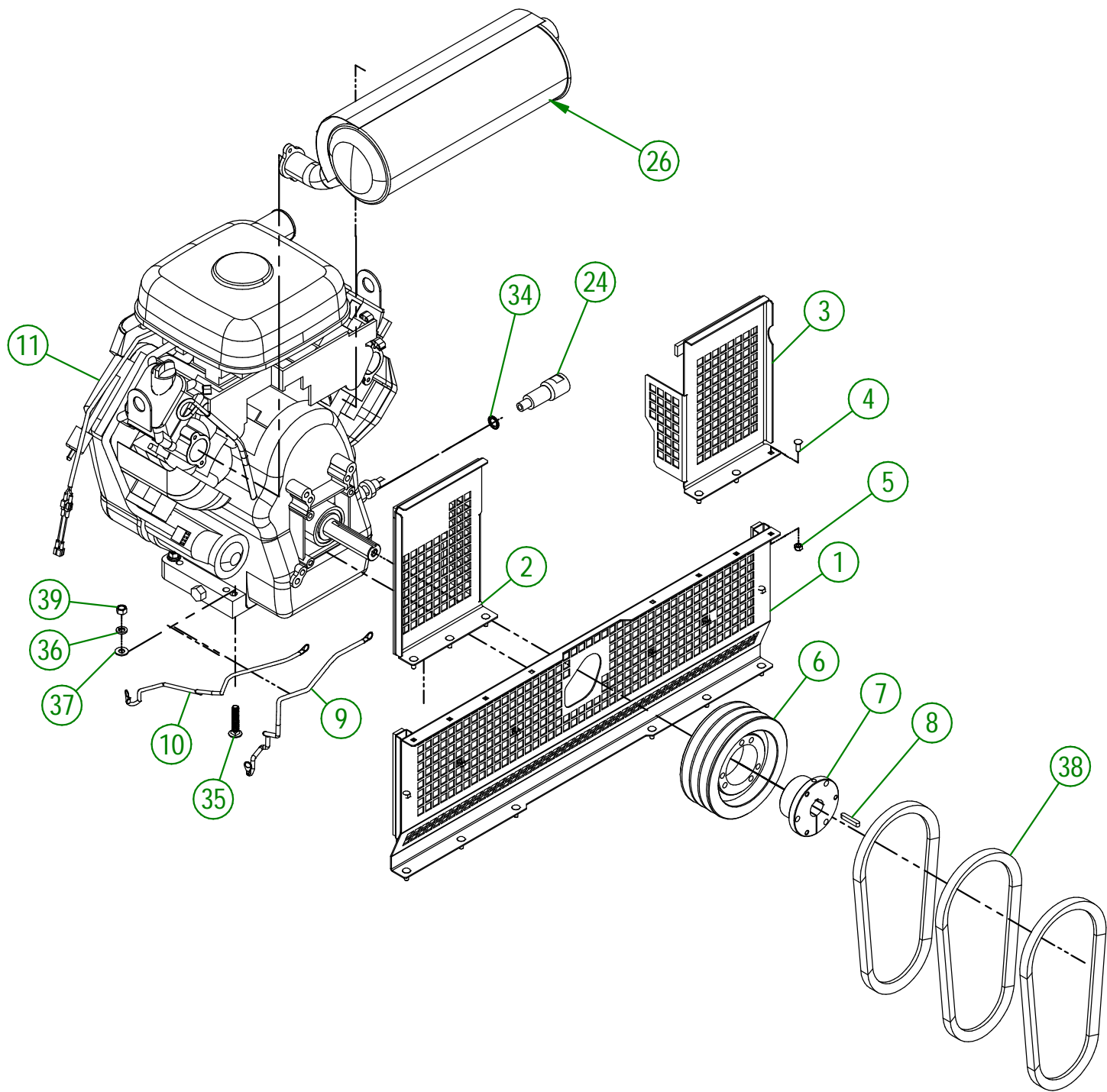

AGRIMETAL	
ASSEMBLY VANGUARD ENGINE 35HP	
CREATION : 06/10/22	ASSEMBLY : 33-57-0545
REVISION : 03/07/23	AUTHOR : D. CHASSÉ

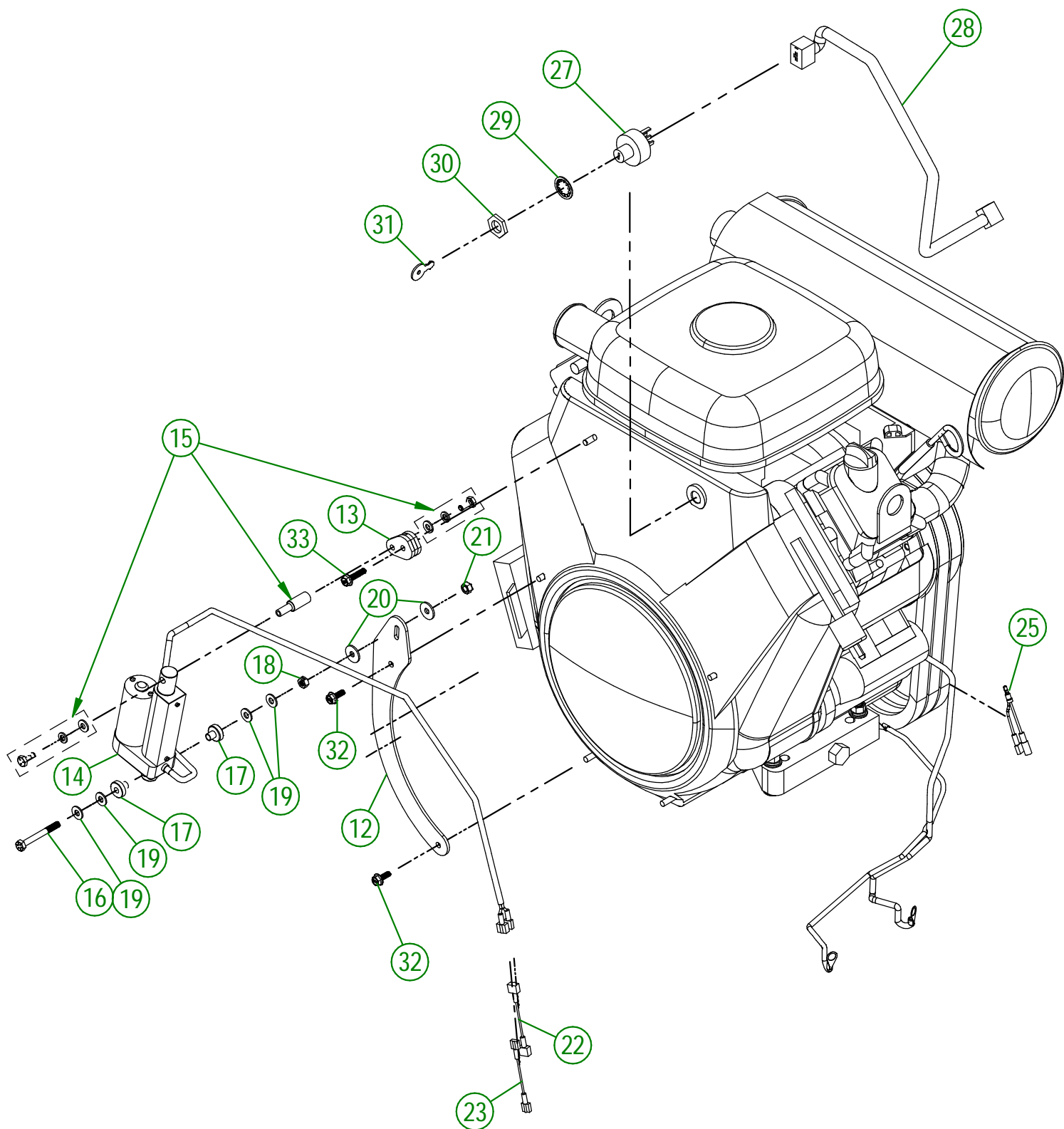

AGRIMETAL	
ASSEMBLY VANGUARD ENGINE 35HP	
CREATION : 06/10/22	ASSEMBLY : 33-57-0545
REVISION : 03/07/23	AUTHOR : D. CHASSÉ

33-57-0545

#	PART #	Qty	TITLE
1	33-57-0590	1	ASSEMBLY BOTTOM ENGINE GUARD
2	33-01-0065	1	MUFFLER GUARD
3	33-01-0075	1	LEFT MUFFLER GUARD
4	NC01-04-0002	6	CARR. BOLT GR2 ZINC 1/4-20 X 5/8"
5	NC01-96-0009	6	NYLON-INSERT LOCKNUT ZINC 1/4-20
6	NC14-62-0220	1	PULLEY QD 3V 1/2-5/8 X 6.75 OD X SD 3B64
7	NC14-62-0004	1	QD BUSHING SD 1 1/8
8	NC01-65-0087	1	KEY 1/4 X 1/4 X 1 1/2"
9	33-55-0506	1	POSITIVE CABLE (14" LG)
10	33-55-0511	1	NEGATIVE CABLE (16" LG)
11	NC14-40-0051	1	VANGUARD ENGINE 35 HP ELECTRIC START
12	33-01-0205	1	ACTUATOR SUPPORT
13	33-50-0200	1	ACTUATOR PIVOT LEVER
14	NC14-35-0232	1	ELECTRIC ACTUATOR 12 VOLTS 1" TRAVEL RUN
15	33-57-0107	1	ACTION ROD
16	NC01-37-0011	1	HEX. BOLT GR8 1/4-28 X 2 1/4
17	33-42-0120	2	PIVOT BUSHING
18	NC02-14-1200	1	TWO WAY LOCK NUT 1/4-28
19	NC02-25-0007	4	WASHER ZINC 0.281 = 9/32
20	36-01-2430	2	FLAT WASHER 14GA X 17/64" I.D. X 13/16" O.D.
21	NC01-97-0004	1	NYLON-INSERT LOCKNUT ZINC 1/4-28
22	33-55-0610	1	16 GA YELLOW CABLE X 2" ASSY.
23	33-55-0615	1	16 GA WHITE CABLE X 2" ASSY.
24	33-21-0125	1	MOTOR DRAIN EXTENSION
25	33-55-0650	1	16 GA BLACK CABLE (Y FOR RECEIVER) HONDA
26	NC13-37-0677	1	35 HP VANGUARD MUFFLER
27	NC13-37-0678	1	IGNITION SWITCH
28	NC13-37-0679	1	WIRE HARNESS ASS'Y
29	NC13-37-0676	1	LOCK WASHER
30	NC13-37-0674	1	HEX NUT
31	NC-13-37-0675	1	KEY SET
32	NC01-50-1172	2	STEEL FLANGED HEX HEAD SCREW M6 X 0.75 X 16MM LG.
33	NC01-50-1172	1	STEEL FLANGED HEX HEAD SCREW M6 X 0.75 X 25MM LG
34	NC13-45-0392	1	METAL BOND SEALING WASHER 13.7MM ID X22.4MM OD
35	NC01-02-0113	4	CARR. BOLT GR2 ZINC 3/8-16 X 2"
36	NC02-32-0012	8	LOCK WASHER ZINC 3/8"
37	01-01-2485	8	FLAT WASHER 14 GA X 13/16"OD X 25/64" ID
38	NC14-25-1070	3	V BELT 21/32 COGGED RAW EDGE BX-31
39	NC02-07-0018	4	HEX. NUT ZINC 3/8-16

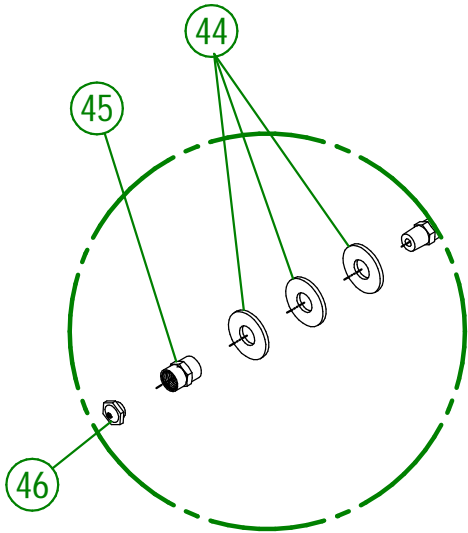

DETAIL C

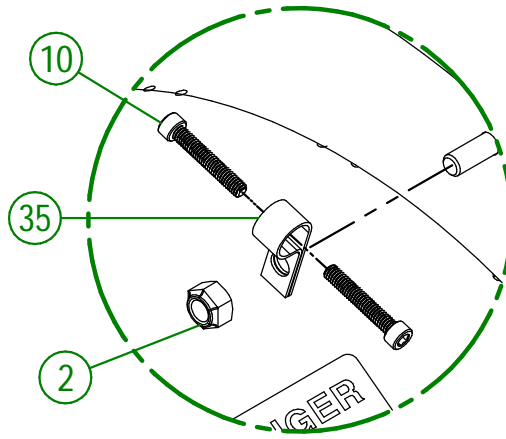

DETAIL A

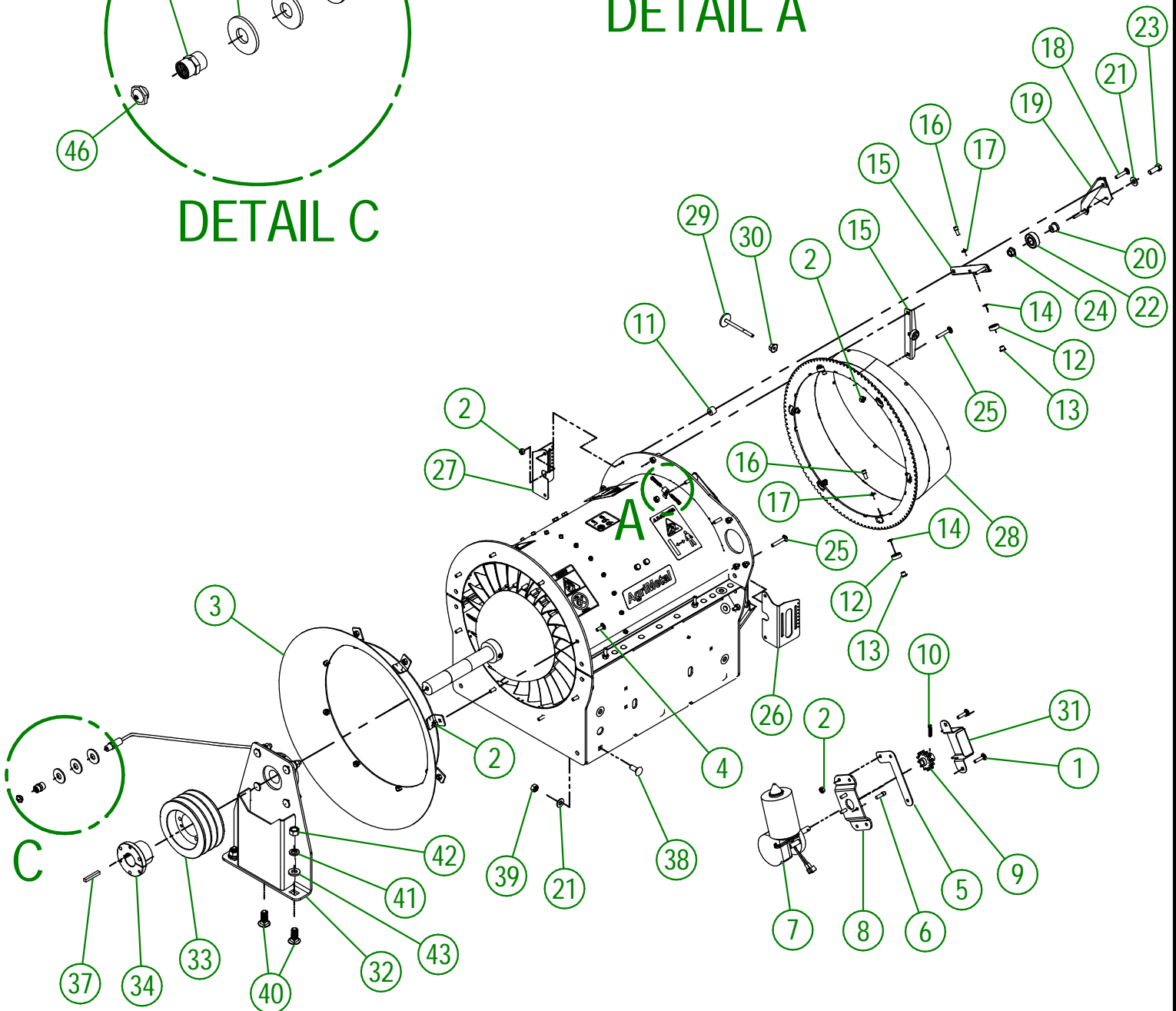

AGRIMETAL	
TURBINE BLOWER GROUP 380 IC	
CREATION : 09/10/18	ASSEMBLY : 33-57-0525
REVISION : 25/10/23	AUTHOR : J.KABWE

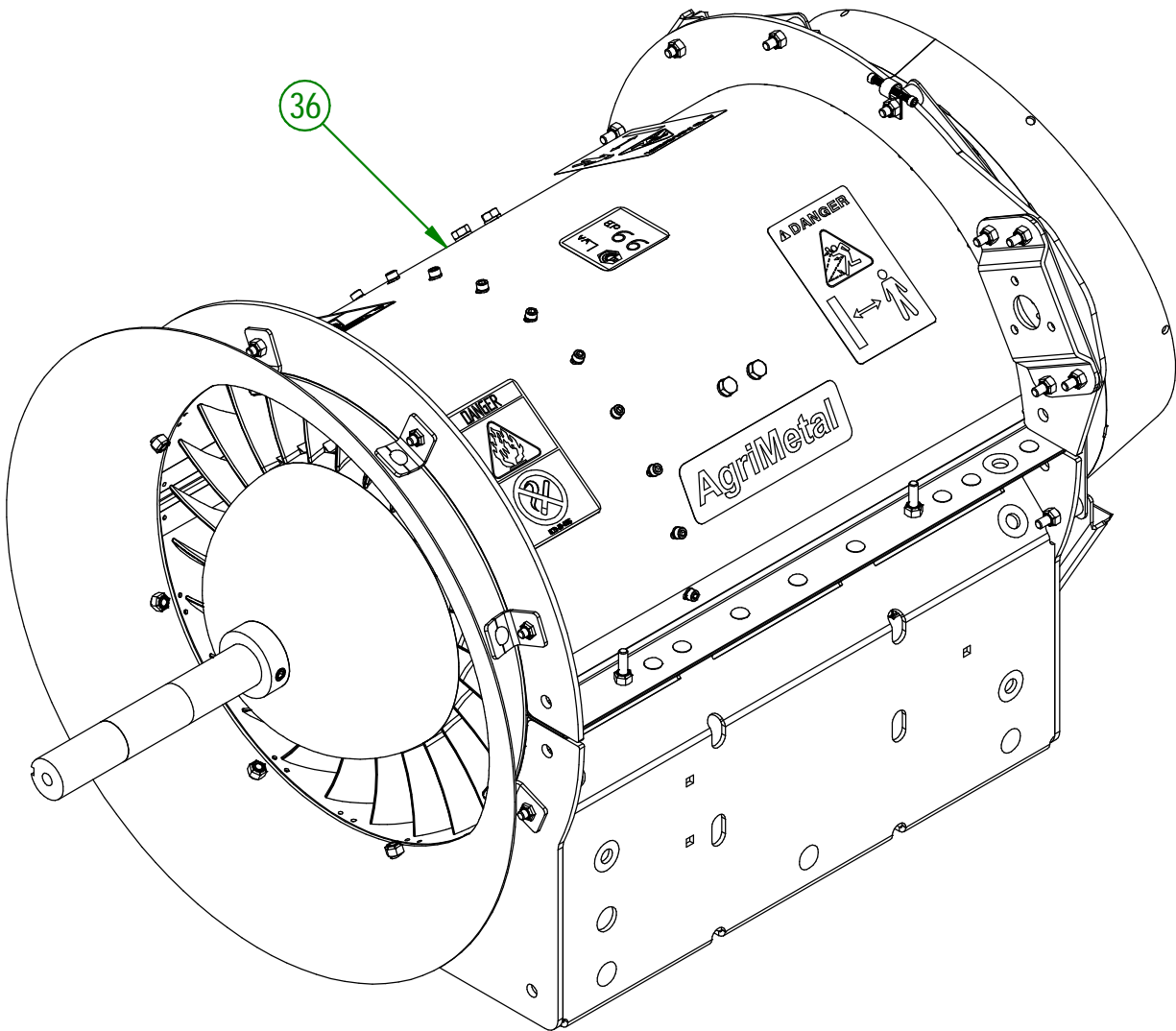

AGRIMETAL	
REGROUP. TURBINE BLOWER 380 IC	
CREATION : 09/10/18	ASSEMBLY : 33-57-0525
REVISION : 25/10/23	AUTHOR : J.KABWE

#	PART #	QTY	TITLE
1	NC01-04-0005	6	CARR. BOLT GR2 ZINC 1/4-20 X 1"
2	NC01-96-0009	45	NYLON-INSERT LOCKNUT ZINC 1/4-20
3	33-55-0085	1	AIR INTAKE ASSY.
4	NC01-04-0003	8	CARR. BOLT GR2 ZINC 1/4-20 X 3/4"
5	33-01-2500	1	ELECTRIC ENGINE SHIM
6	NC02-51-0080	3	SOCKET CAP SCREW T.RON 1/4-28 X 3/4"
7	33-55-0045	1	DEFLECTOR ELECTRIC ENGINE
8	33-01-0933	1	ELECTRIC ENGINE SUPPORT
9	33-55-0035	1	GEARED CROWN SPROCKET
10	NC02-50-0069	3	SOCKET CAP SCREW T.RON 8-32 X 1"
11	33-21-0080	12	SPACER
12	NC14-75-0153	12	BALL BEARING R6 2RS 3/8" X 7/8" X 0.281"
13	33-25-2410	12	BEARING BUSHING
14	33-03-4605	12	BEARING SHIM 1/4" ALUMINUM
15	33-01-2425	6	BEARING HOLDER BRACKET
16	NC02-51-0578	12	SOCKET CAP SCREW T.RON. NF 1/4-28 X 1/2 STAINLESS
17	NC02-32-0010	12	LOCK WASHER ZINC 1/4"
18	NC01-04-0006	7	CARR. BOLT GR2 ZINC 1/4-20 X 1 1/4"
19	33-50-0555	3	WELD ASSEMBLY BEARING SUPPORT
20	33-21-0060	3	BEARING HOLDER
21	01-01-2485	9	FLAT WASHER 14 GA X 13/16"OD X 25/64" ID
22	NC14-75-0068	3	BALL BEARING 99502H
23	NC01-17-0114	3	HEX. BOLT GR2 ZINC 3/8-16 X 1"
24	NC02-14-0019	3	FLANGE NUT HEX. NC 3/8-16 GR. B
25	NC01-04-0007	5	CARR. BOLT GR2 ZINC 1/4-20 X 1 1/2"
26	33-01-2452	1	LEFT MICRO SWITCH SUPPORT
27	33-01-2450	1	RIGHT MICRO SWITCH SUPPORT
28	33-50-0515	1	WELD ASSEMBLY CROWN DEFLECTOR
29	33-50-1540	1	MICRO SWITCH STOPPER
30	NC02-14-0017	1	FLANGED NUT GR. B 1/4-20
31	33-01-3095	1	SPROCKET GUARD
32	33-55-0590	1	BEARING SUPPORT
33	NC14-62-0201	1	PULLEY QD 3V 1/2-5/8 X 5.55 OD X SD 3B52
34	NC14-62-0005	1	QD BUSHING SD 1 1/4"
35	NC13-25-0233	1	VINYLE PROTECTOR COLLAR
36	33-57-0520	1	TURBINE 380 IC (NEW)
37	33-41-0920	1	SQUARE KEY
38	NC01-04-0109	6	CARR. BOLT GR2 ZINC 3/8-16 X 1"
39	NC01-93-0011	6	LOCK NUT 3/8-16
40	NC01-04-0234	3	CARR. BOLT GR2 ZINC 1/2-13 X 1 1/4
41	NC02-32-0014	3	LOCK WASHER ZINC 1/2"
42	NC02-07-0020	3	HEX. NUT ZINC 1/2-13
43	01-01-0925	3	WASHER
44	NC02-22-0012	3	WASHER ZINC 1/2 BOLT = 9/16"Ø X 1 3/8" OD
45	NC13-65-0001	1	UNION 1/4" NPT X 7/8"
46	NC01-69-0798	1	GREASE FITTING 1/4" NPT X RIGHT

#	PART #	Qty	TITLE
1	33-50-0560	1	BEARING HOLDER
2	33-09-0000	4	ROLLER BEARING BUSHING
3	33-38-0000	1	FLANGE BEARING UCF 207-20 X Ø 1 1/4" X Ø 1/8 NPT
4	NC01-04-0111	4	CARR. BOLT GR2 ZINC 3/8-16 X 1 1/2"
5	01-01-2485	4	FLAT WASHER 14 GA X 13/16"OD X 25/64" ID
6	NC02-32-0012	4	LOCK WASHER ZINC 3/8"
7	NC02-07-0018	4	HEX. NUT ZINC 3/8-16
8	NC17-02-0366	1	HYDRAULIC HOSE 1/4 X 18" CUT 1/8 NPTMALE RIG.X 1/4NPTMALE RIG
9	40-22-2200	4	SPECIAL WASHER

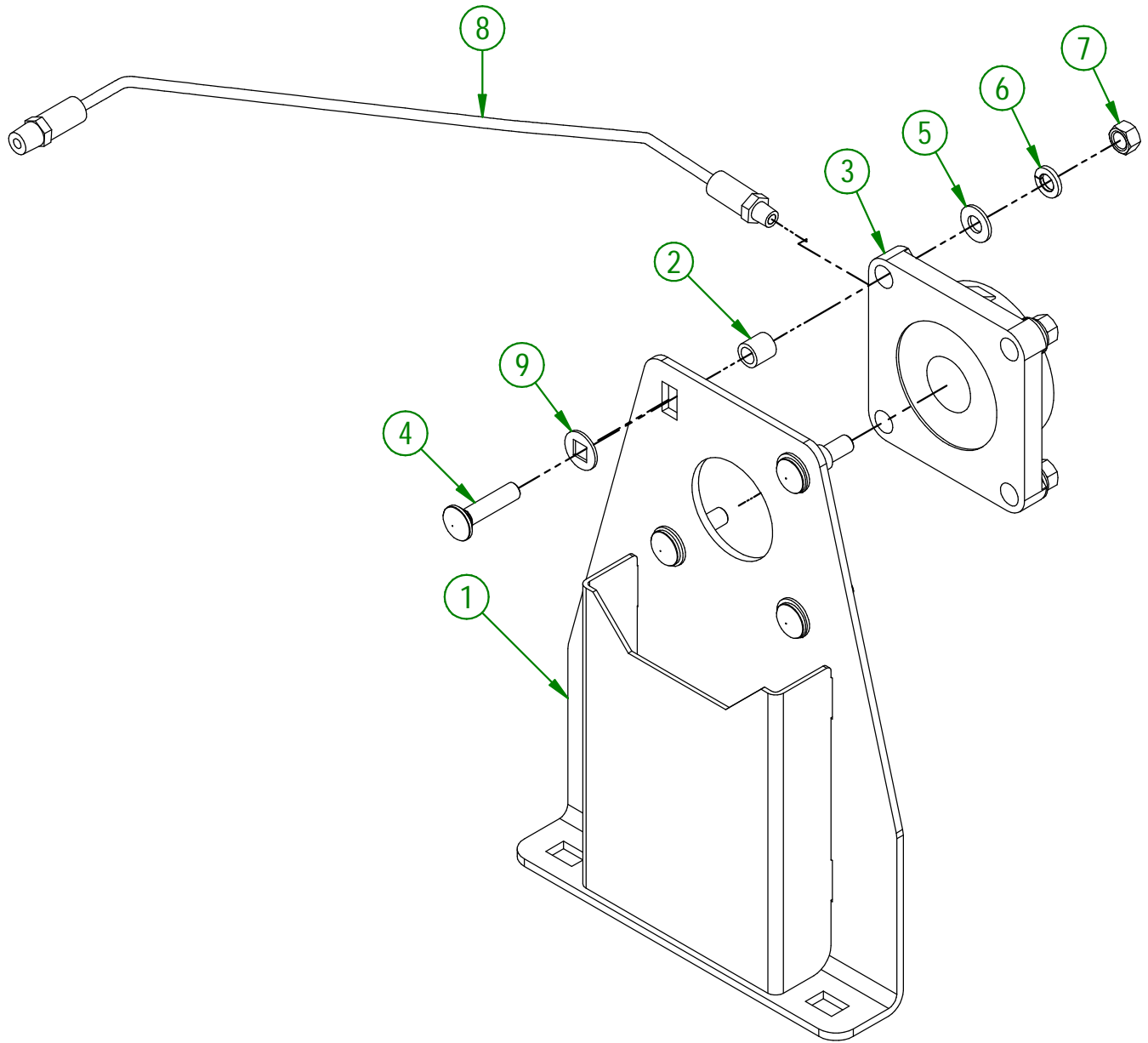

AGRIMETAL
BEARING SUPPORT

CREATION : 06/12/17
REVISION : 08/04/24

ASSEMBLY : **33-55-0590**
AUTHOR : J.KABWE

#	PART #	Qty	TITLE
1	NC01-96-0009	2	NYLON-INSERT LOCKNUT ZINC 1/4-20
2	NC01-04-0027	2	CARR. BOLT 1/4-20 X 6" LG
3	NC01-04-0056	2	CARR. BOLT 5/16-18 X3/4"
4	33-01-3015	1	BATTERY STRAPE
5	NC02-32-0011	2	LOCK WASHER ZINC 5/16"
6	NCI3-12-0001	1	12 VOLTS BATTERY
7	NC02-07-0017	2	HEX. NUT 5/16-18
8	NCI3-80-0267	1	RED PROTECTOR FOR BATTERY POST
9	NCI3-80-0268	1	BLACK PROTECTOR FOR BATTERY POST
10	33-01-4000	1	HOUR METER HOLDER
11	NCI3-37-0669	1	HOUR METER

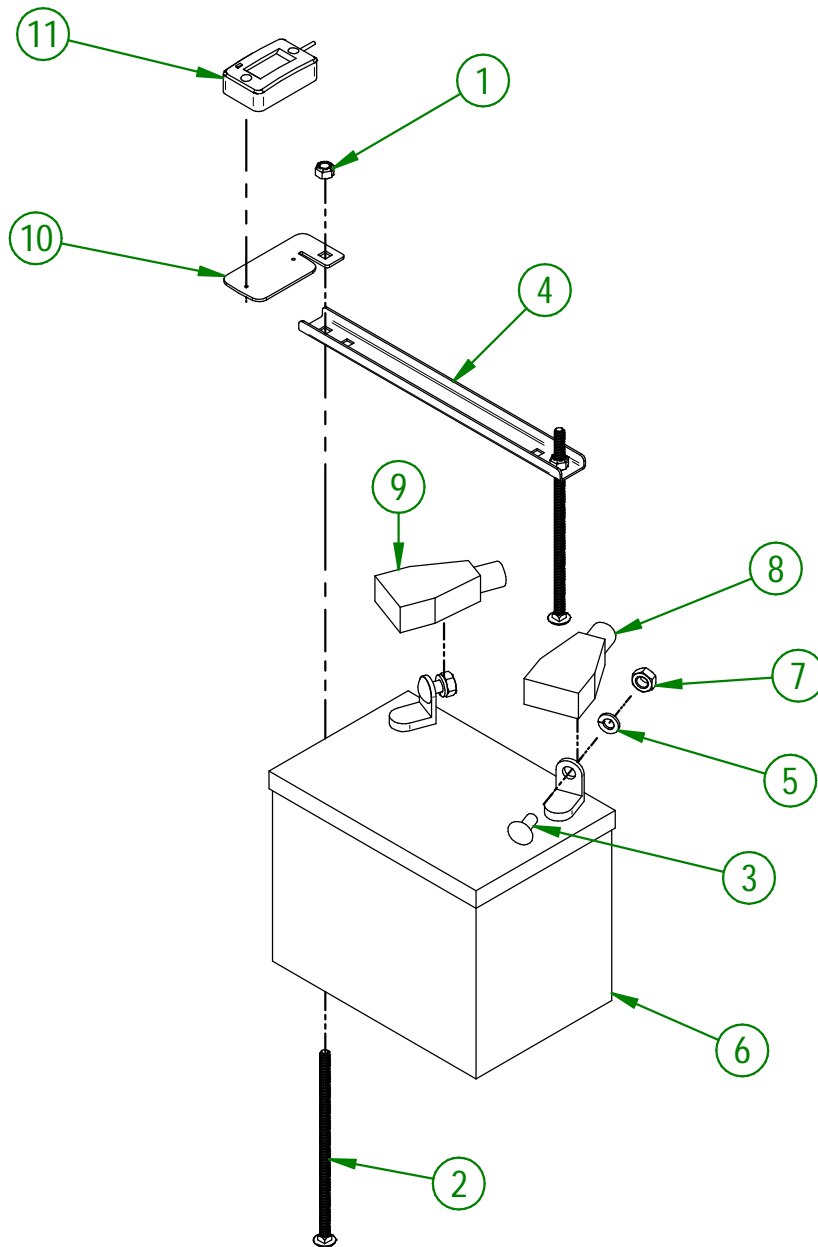

USE THESE PIECES ONLY IF YOUR SERIAL NUMBER IS AFFECTED:

BELOW # 44661

AGRIMETAL	
12 VOLTS BATTERY GROUP.	
CREATION : 31/10/17	ASSEMBLY : 33-57-0055
REVISION : 11/09/23	AUTHOR : J.KABWE

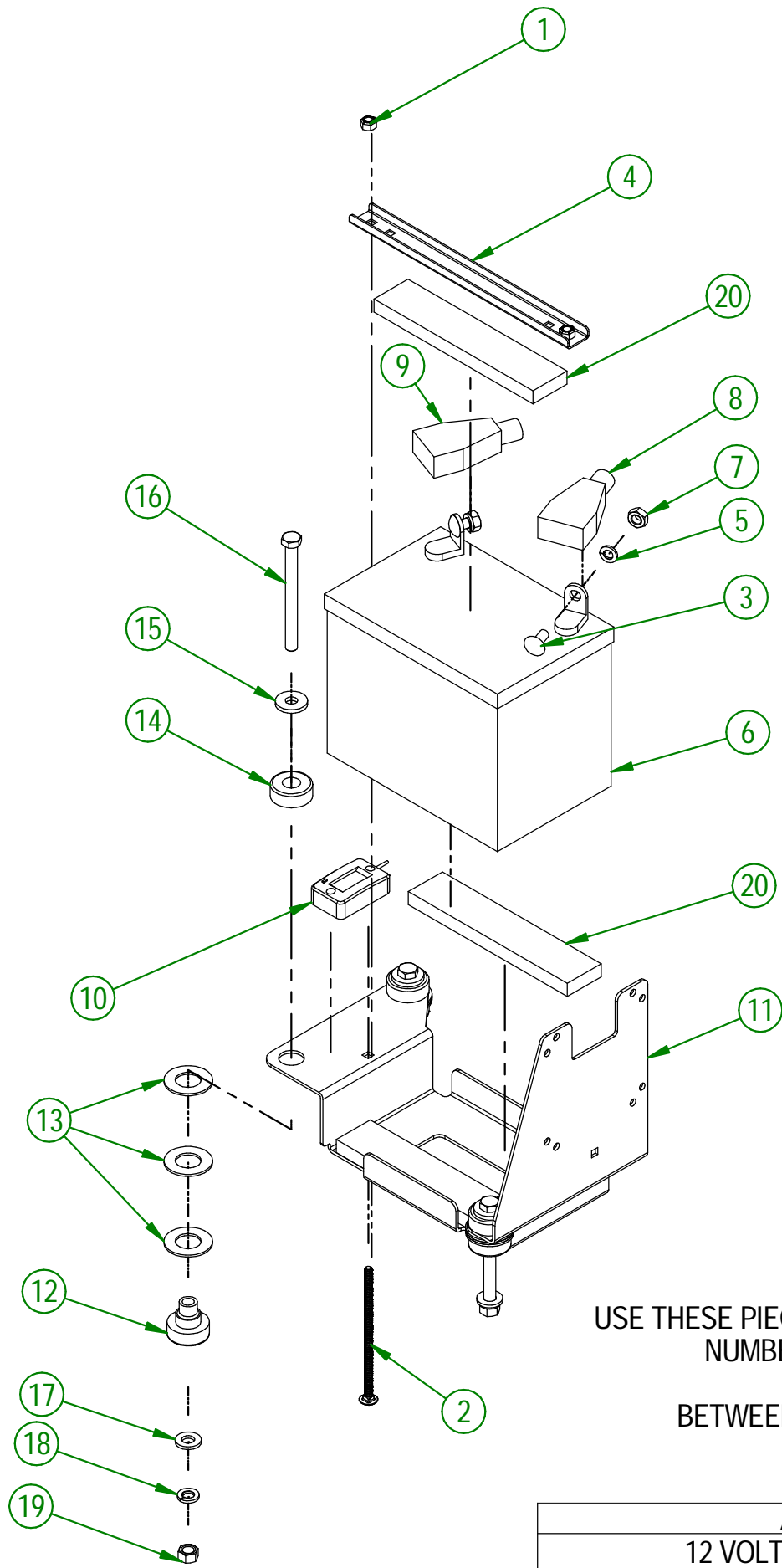

USE THESE PIECES ONLY IF YOUR SERIAL NUMBER IS AFFECTED:

BETWEEN #44661 & #45502

AGRIMETAL	
12 VOLTS BATTERY GROUP.	
CREATION : 29/08/23	ASSEMBLY : 33-57-0057
REVISION : 20/03/24	AUTHOR : D. CHASSÉ

33-57-0057

#	PART #	Qty	TITLE
1	NC01-96-0009	2	NYLON-INSERT LOCKNUT ZINC 1/4-20
2	NC01-04-0024	2	CARR. BOLT GR2 ZINC 1/4-20 X 5"
3	NC01-04-0056	2	CARR. BOLT 5/16-18 X3/4"
4	33-01-3015	1	BATTERY STRAPE
5	NC02-32-0011	2	LOCK WASHER ZINC 5/16"
6	NC13-12-0017	1	12 VOLTS GEL BATTERY
7	NC02-07-0017	2	HEX. NUT 5/16-18
8	NC13-80-0267	1	RED PROTECTOR FOR BATTERY POST
9	NC13-80-0268	1	BLACK PROTECTOR FOR BATTERY POST
10	NC13-37-0669	1	HOUR METER
11	33-57-2400	1	BATTERY SUPPORT PLATE "INCL. STICKER"
12	NC13-15-0354	3	RED RUBBER BASE MOUNT
13	26-03-4800	9	WASHER
14	NC13-15-0354	3	RED RUBBER BASE MOUNT
15	21-01-0950	3	FLAT WASHER 10GA 1.005" DIA X 25/64"
16	NC01-25-0126	3	HEX. BOLT GR5 ZINC 3/8-16 X 4"
17	NC02-25-0009	3	WASHER 0.406" I.D. X 0.815 O.D.
18	NC02-32-0012	3	LOCK WASHER ZINC 3/8"
19	NC02-07-0018	3	HEX. NUT ZINC 3/8-16
20	33-42-0130	3	BLACK ADHESIVE-BACK STRIP

#	PART #	Qty	TITLE
1	NC01-04-0056	2	CARR. BOLT 5/16-18 X3/4"
2	NC02-32-0011	2	LOCK WASHER ZINC 5/16"
3	NCI3-12-0017	1	12 VOLTS GEL BATTERY
4	NC02-07-0017	2	HEX. NUT 5/16-18
5	NCI3-80-0267	1	RED PROTECTOR FOR BATTERY POST
6	NCI3-80-0268	1	BLACK PROTECTOR FOR BATTERY POST
7	NCI3-37-0669	1	HOUR METER
8	33-57-2401	1	BATTERY SUPPORT PLATE "INCL. STICKER"
9	NCI3-15-0354	3	RED RUBBER BASE MOUNT
10	26-03-4800	9	WASHER
11	NCI3-15-0354	3	RED RUBBER BASE MOUNT
12	21-01-0950	3	FLAT WASHER IOGA 1.005" DIA X 25/64"
13	NC01-25-0126	3	HEX. BOLT GR5 ZINC 3/8-16 X 4"
14	NC02-25-0009	3	WASHER 0.406" I.D. X 0.815 O.D.
15	NC02-32-0012	3	LOCK WASHER ZINC 3/8"
16	NC02-07-0018	3	HEX. NUT ZINC 3/8-16
17	33-42-0130	2	BLACK ADHESIVE-BACK STRIP
18	NCI3-15-0008	1	RUBBER STRAP
19	33-42-0135	2	BLACK ADHESIVE-BACK STRIP

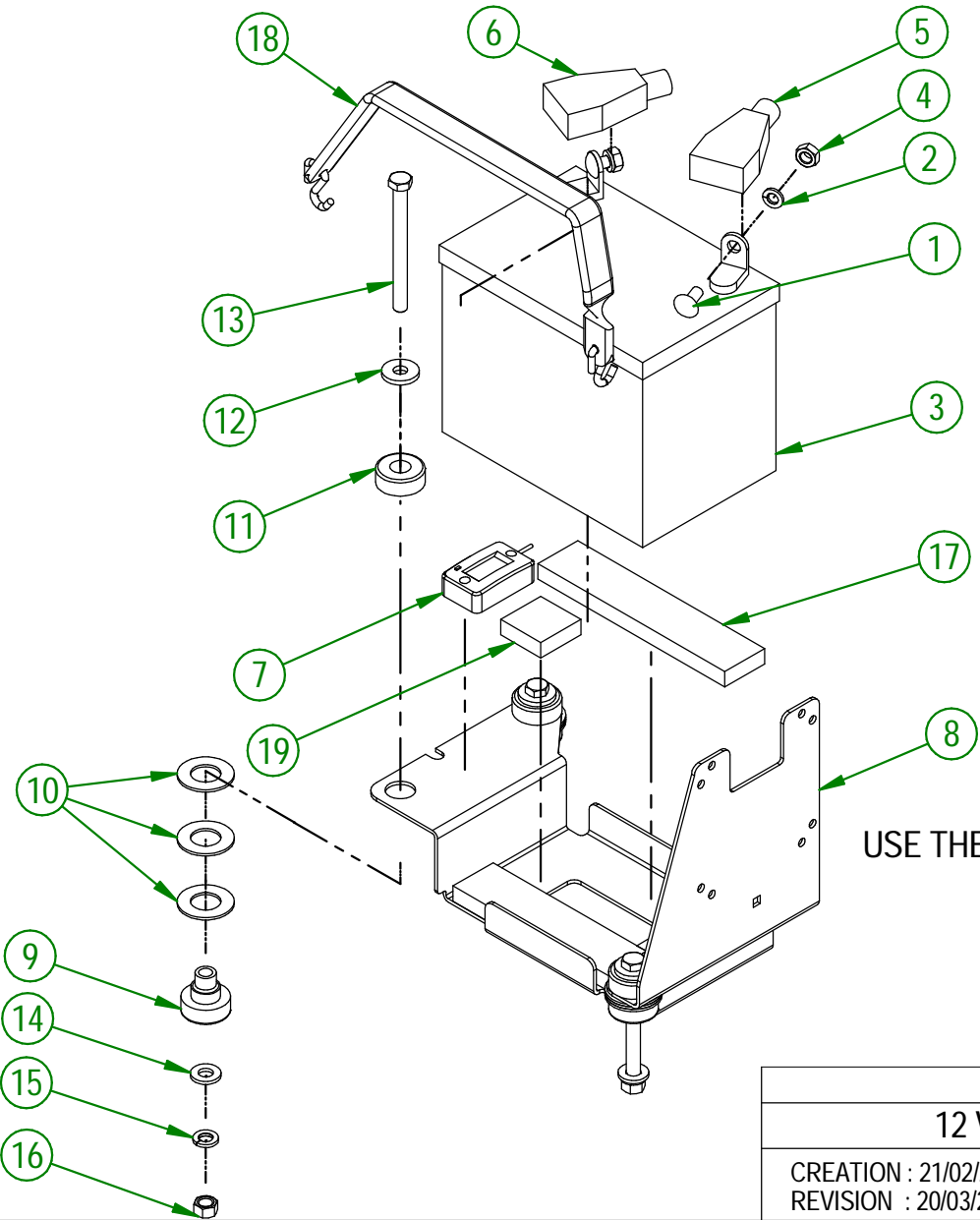

USE THESE PIECES ONLY IF YOUR SERIAL NUMBER IS AFFECTED:

#45503 AND ABOVE

AGRIMETAL	
12 VOLTS BATTERY GROUP.	
CREATION : 21/02/24	ASSEMBLY : 33-57-0170
REVISION : 20/03/24	AUTHOR : D. CHASSÉ

#	PART #	Qty	TITLE
1	NC13-30-0237	1	PLASTIC TUBE FOR OPERATOR'S MANUAL
2	NC02-25-0007	3	WASHER ZINC 0.281 = 9/32
3	NC01-17-0004	3	HEX. BOLT GR2 ZINC 1/4-20 X 3/4"
4	36-01-2430	3	WASHER
5	NC01-96-0009	3	NYLON-INSERT LOCKNUT ZINC 1/4-20
6	33-98-0530	1	OPERATOR MANUAL TB 380

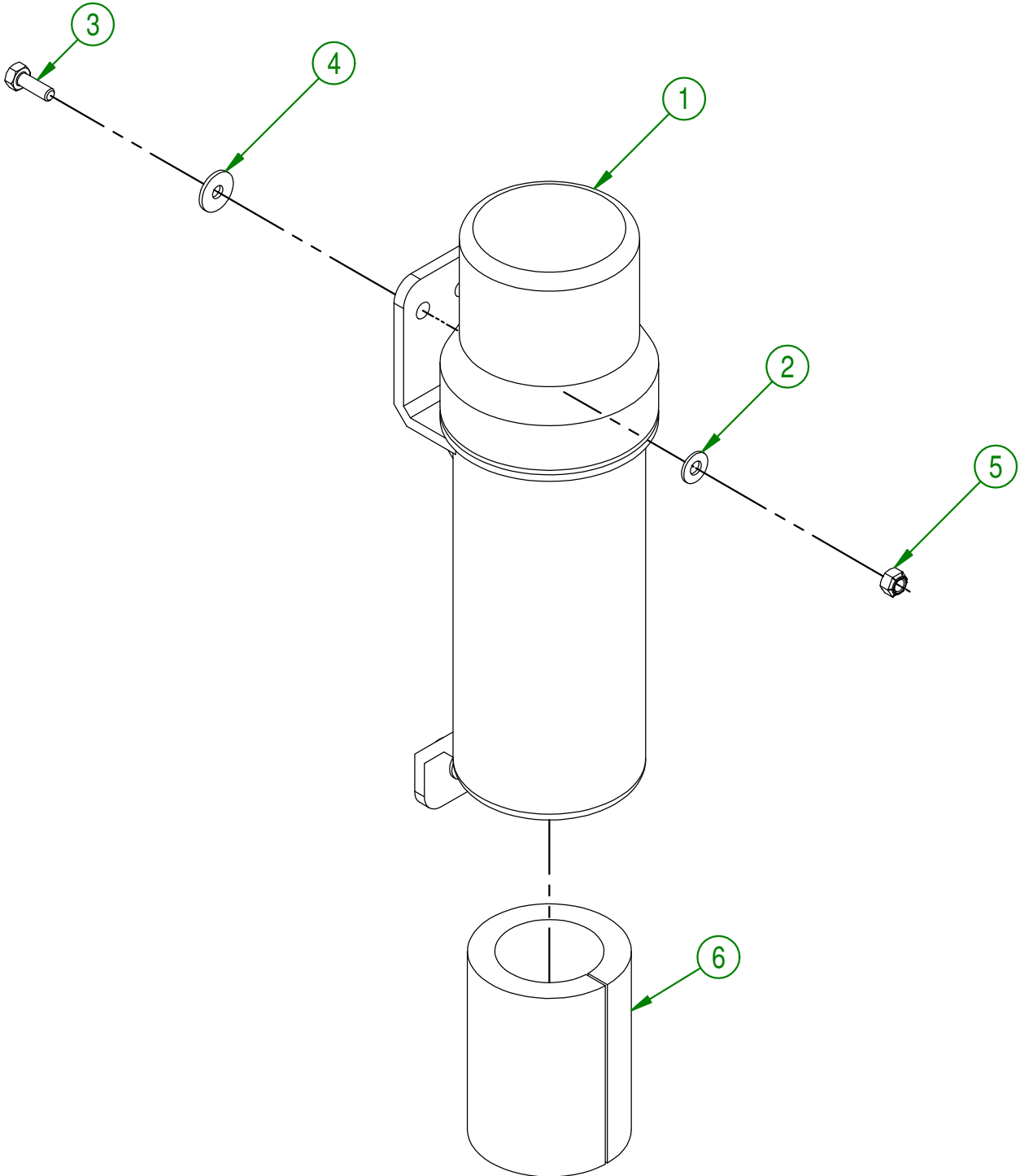

AGRIMETAL	
ASSEMBLY OPERATOR MANUEL TUBE	
CREATION : 09/11/17	ASSEMBLY : 33-57-0565
REVISION : 10/10/18	AUTHOR : J.KABWE Page 20 de 21

#	PART #	Qty	TITLE
1	NCI3-33-0052	2	STICKER FRAME LEVEL
2	NCI3-33-0183	1	STICKER CAUTION OPERATION MANUAL
3	NCI3-33-2675	2	STICKER TO INFLATE TIRE
4	NCI3-33-0227	1	STICKER FUSE 15 AMP MAXIMUM
5	NCI3-33-0266	1	STICKER IMPORT 6" 152 MM
6	NCI3-33-0192	2	STICKER (PROJECTION RISK)
7	NCI3-33-0185	2	STICKER PICTOGRAM (FIRE + CIGARETTE)
8	NCI3-33-0002	2	STICKER AGRIMETAL
9	NCI3-33-0342	1	STICKER 99 DB
10	NCI3-33-0024	1	STICKER GREASE HERE
11	NCI3-33-0178	1	STICKER IMPORTANT PLEASE CHECK OIL LEVEL...
12	NCI3-33-2674	2	STICKER TO PROGRAM REMOTE CONTROL

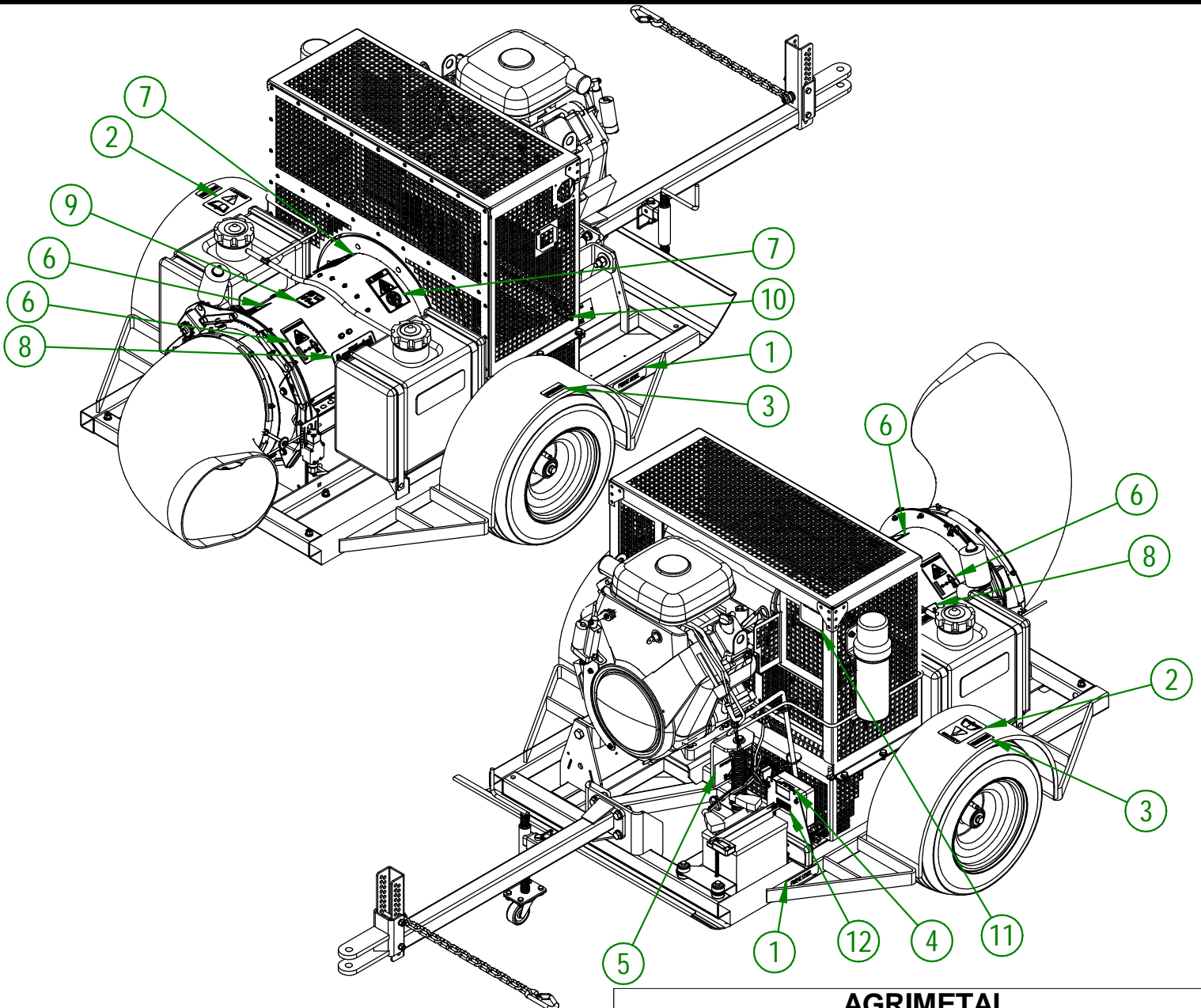
**AGRIMETAL****TURBINE BLOWER 350 IC**

CREATION : 03/10/22
 REVISION : 27/10/23

ASSEMBLY : **33-99-0600**
 AUTHOR : D. CHASSÉ