

AgriMetal

PART LIST

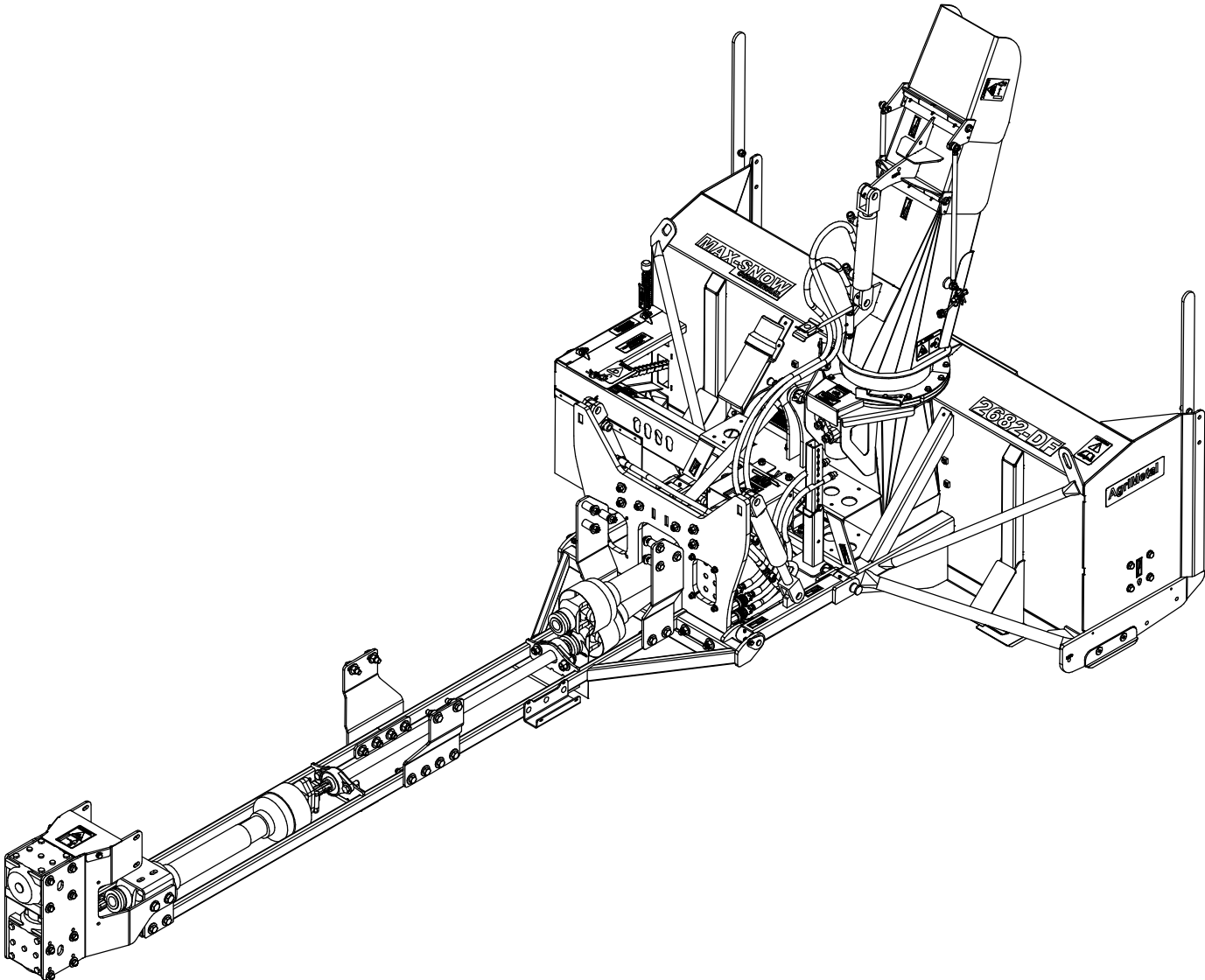

MS 2682-DF-JD-2

80-57-0700

#	PART #	Qty	TITLE
1	80-50-0085	2	LATERAL SKATE (#450 HARDNESS STEEL)
2	80-50-0055	2	ADJUSTABLE SKATE (STEEL)
3	NC02-48-0586	4	FLAT HEAD SOCKET CAP SCREW 5/8-11 X 1" LG
4	80-57-0065	2	KNIFE (#450 HARDNESS STEEL) GROUP (BOLTS AND NUTS INCLUDED)

80-57-0065

#	PART #	Qty	TITLE
5	NC01-09-0029	5	PLOW BOLT GR5 1/2-13 X 1 1/4" LG
6	NC01-93-0014	5	LOCK NUT ZINC 1/2-13

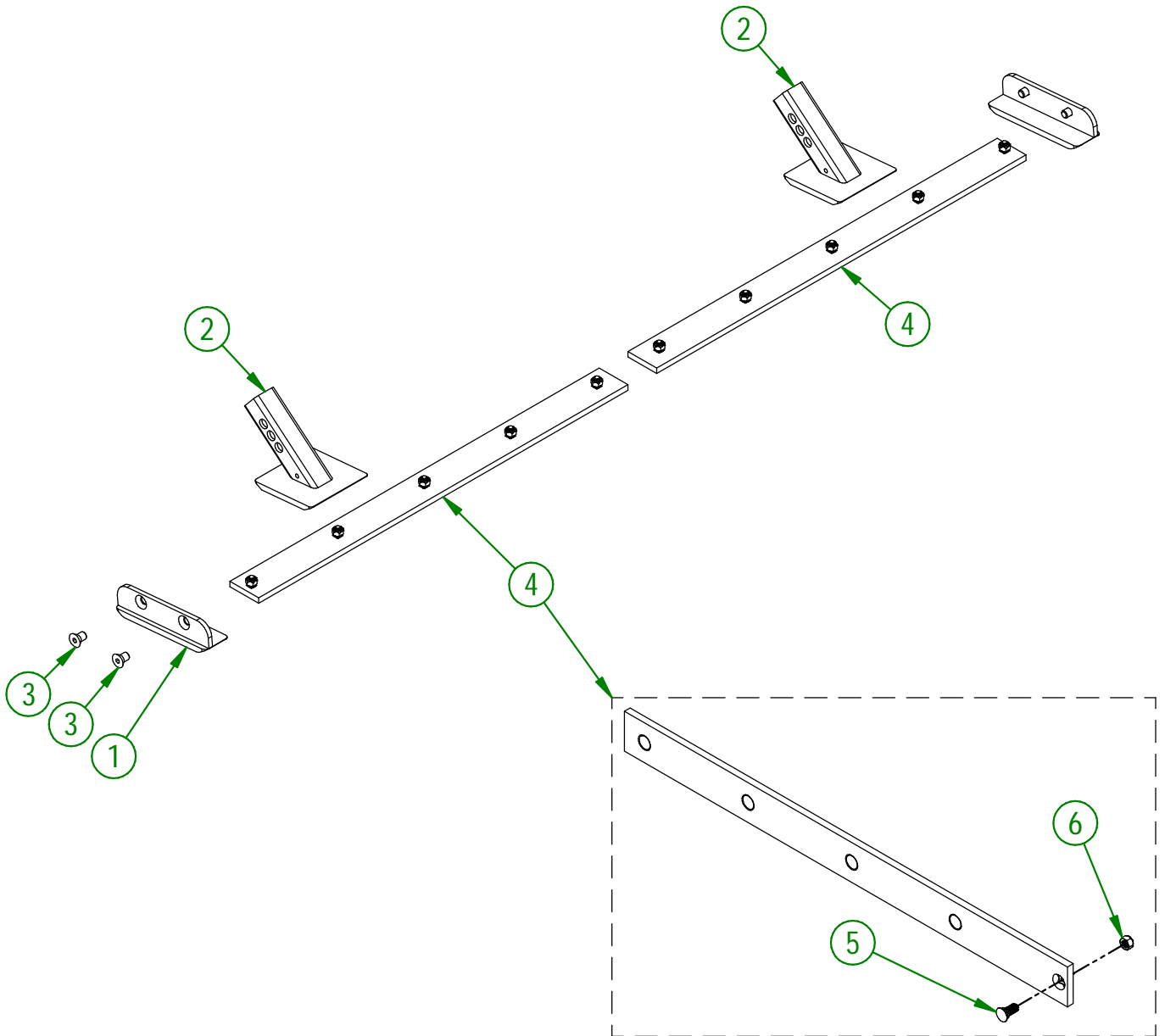

AGRIMETAL	
SET OF KNIVES (#450 HARDNESS STEEL)	
CREATION : 26/01/22	ASSEMBLY : 80-57-0700
REVISION : 26/09/23	AUTHOR : Dessin2

#	PART #	Qty	TITLE
1	80-50-0700	2	KNIFE BRACE (TOP)
2	80-42-0135	1	RIGHT KNIFE (UHMW)
3	80-42-0136	1	LEFT KNIFE (UHMW)
4	80-04-0335	2	KNIFE BRACE (UNDER)
5	NC02-48-0548	18	FLAT HEAD SOCKET CAP SCREW STAINLESS 1/2-13 X 2"
6	NC01-93-0014	22	LOCK NUT ZINC 1/2-13
7	80-42-0157	1	LATERAL KNIFE (RIGHT)
8	80-42-0155	1	LATERAL KNIFE (LEFT)
9	80-04-0185	6	WASHER
10	NC01-17-0394	6	HEX. BOLT GR2 ZINC 5/8-11 X 1 1/2"
11	NC02-25-0011	4	WASHER SAE ZINC 17/32 ID
12	NC01-17-0250	2	HEX. BOLT GR2 ZINC 1/2-13 X 1 3/4"
13	NC01-17-0251	2	HEX. BOLT GR2 ZINC 1/2-13 X 2"

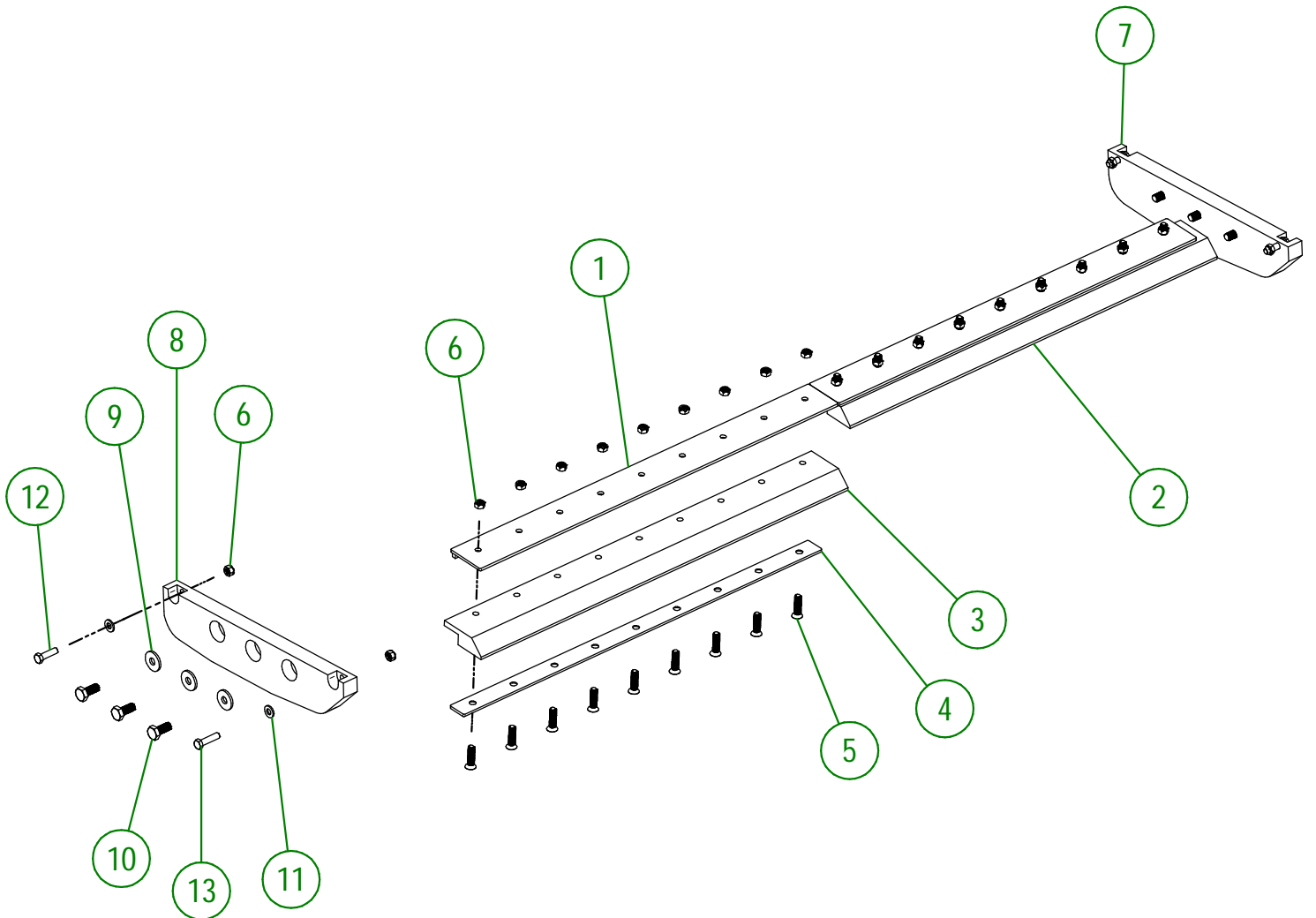

AGRIMETAL	
SET OF KNIVES (UHMW)	
CREATION : 26/01/22	ASSEMBLY : 80-57-0705
REVISION : 27/09/23	AUTHOR : J. HOULE

80-57-0710

#	PART #	Qty	TITLE
1	80-50-0087	2	LATERAL SKATE (STAINLESS STEEL)
2	80-50-0058	2	ADJUSTABLE SKATE (STAINLESS STEEL)
3	NC02-48-0586	4	FLAT HEAD SOCKET CAP SCREW 5/8-11 X 1" LG
4	80-57-0070	2	KNIFE (STAINLESS STEEL) GROUP (BOLTS AND NUTS INCLUDED)

80-57-0070

#	PART #	Qty	TITLE
5	NC02-48-0545	9	FLAT HEAD SOCKET CAP SCREW 1/2"-13 X 1 1/4" (STAINLESS STEEL)
6	NC01-93-0014	9	LOCK NUT ZINC 1/2-13

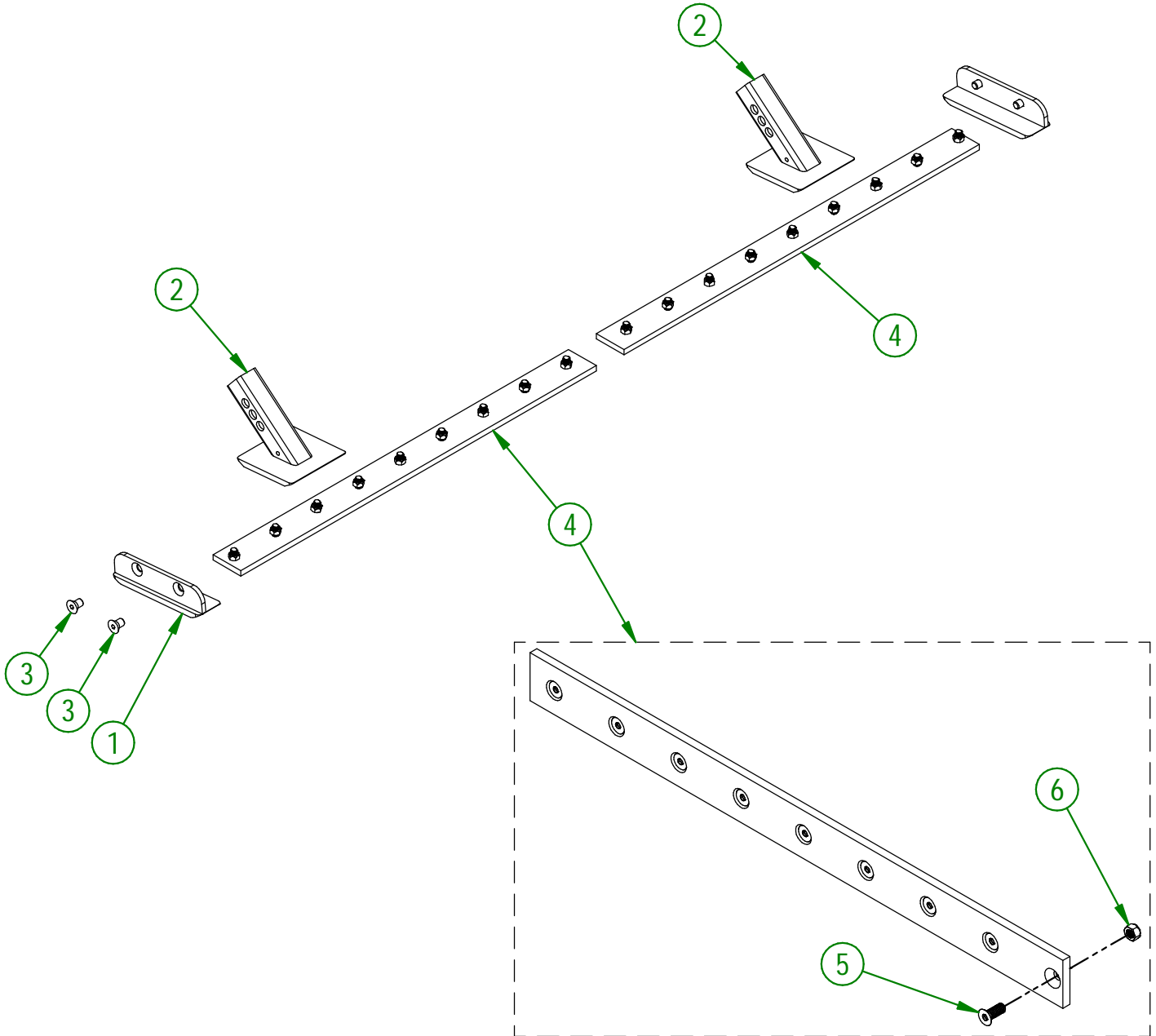

AGRIMETAL	
SET OF KNIVES (STAINLESS STEEL)	
CREATION : 26/01/22	ASSEMBLY : 80-57-0710
REVISION : 26/09/23	AUTHOR : Dessin2

#	PART #	Qty	TITLE
1	NC01-69-0785	2	STRAIGHT GREASE FITTING 1/4-28
2	80-50-0093	1	STAND
3	NC01-69-1306	1	LOCKING PIN 3/8" X 2 1/2" LG
4	NC13-15-0300	1	SNOW GUARD
5	80-01-1075	1	SNOW GUARD BRACE
6	NC01-78-0016	6	ALUMINIUM BLIND POP RIVET STEEL MANDREL 0.187 X 0.690
7	NC01-63-0026	1	COTTER PIN ZC 5/32" X 3"
8	NC13-15-0320	1	RUBBER
9	80-57-0060	1	RUBBER REINFORCEMENT
10	NC01-17-0060	5	HEX. BOLT GR2 ZINC 5/16-18 X 1"
11	NC01-93-0010	5	LOCK NUT ZINC 5/16-18
12	80-57-5715	1	FRAME
13	NC01-25-0481	2	HEX. BOLT GR5 NC 3/4-10 X 5"
14	NC01-96-0017	2	HEX. LOCK NUT NYLO. NC 3/4-10

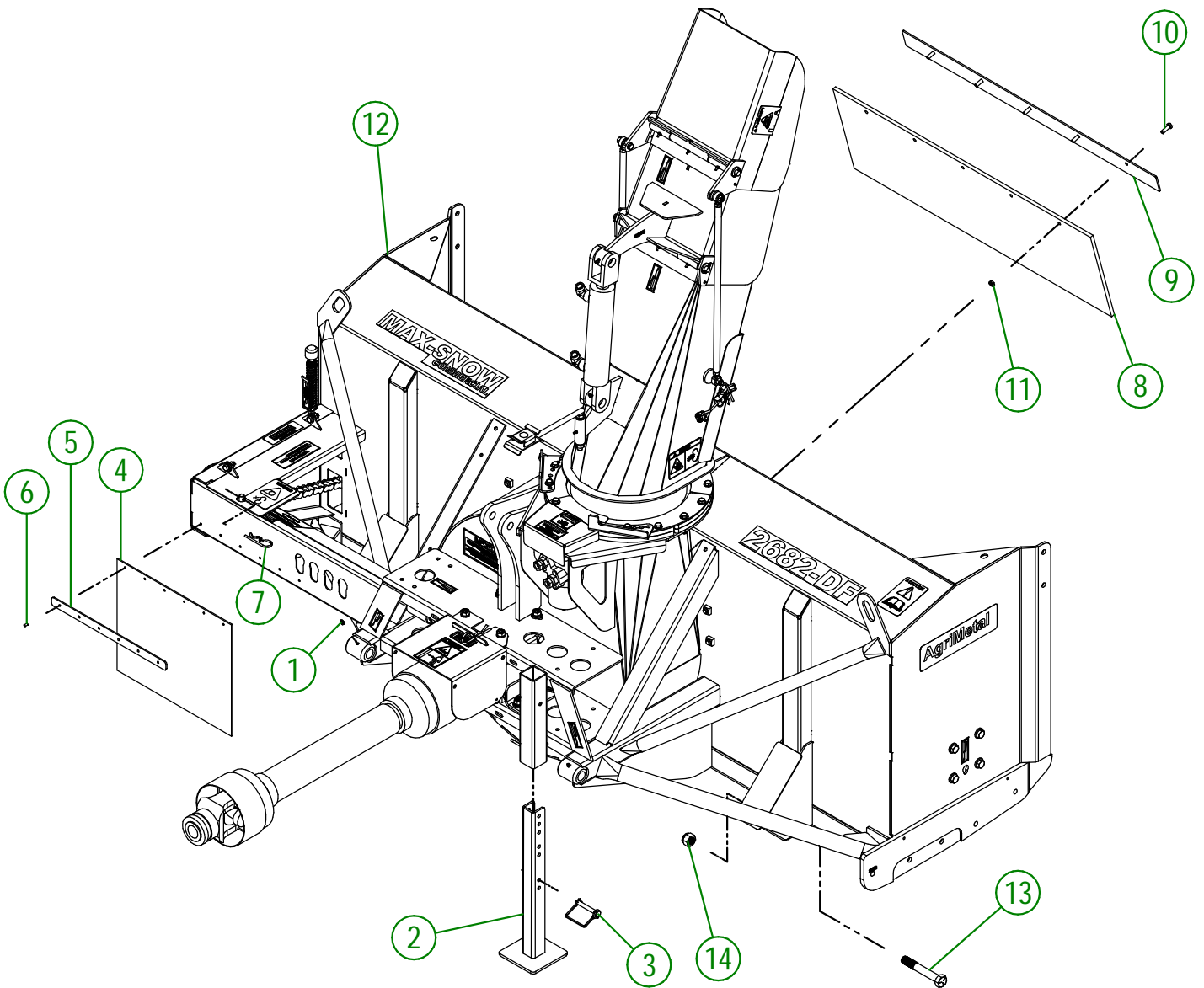

AGRIMETAL	
FRONT SNOWBLOWER GROUP	
CREATION : 26/01/22	ASSEMBLY : 80-57-5710
REVISION : 21/09/22	AUTHOR : J. Houle

#	PART #	Qty	TITLE
1	80-50-5050	1	IMPELLER
2	80-04-0185	1	WASHER
3	NC02-32-0016	1	LOCK WASHER ZINC 5/8"
4	NC01-17-0395	1	HEX. BOLT GR2 ZINC 5/8-11 X 1 3/4"
5	NC01-94-0011	2	LOCK NUT 3/8-24
6	NC01-37-0121	2	HEX. BOLT GR8 ZINC 3/8-24 X 2 3/4" LG

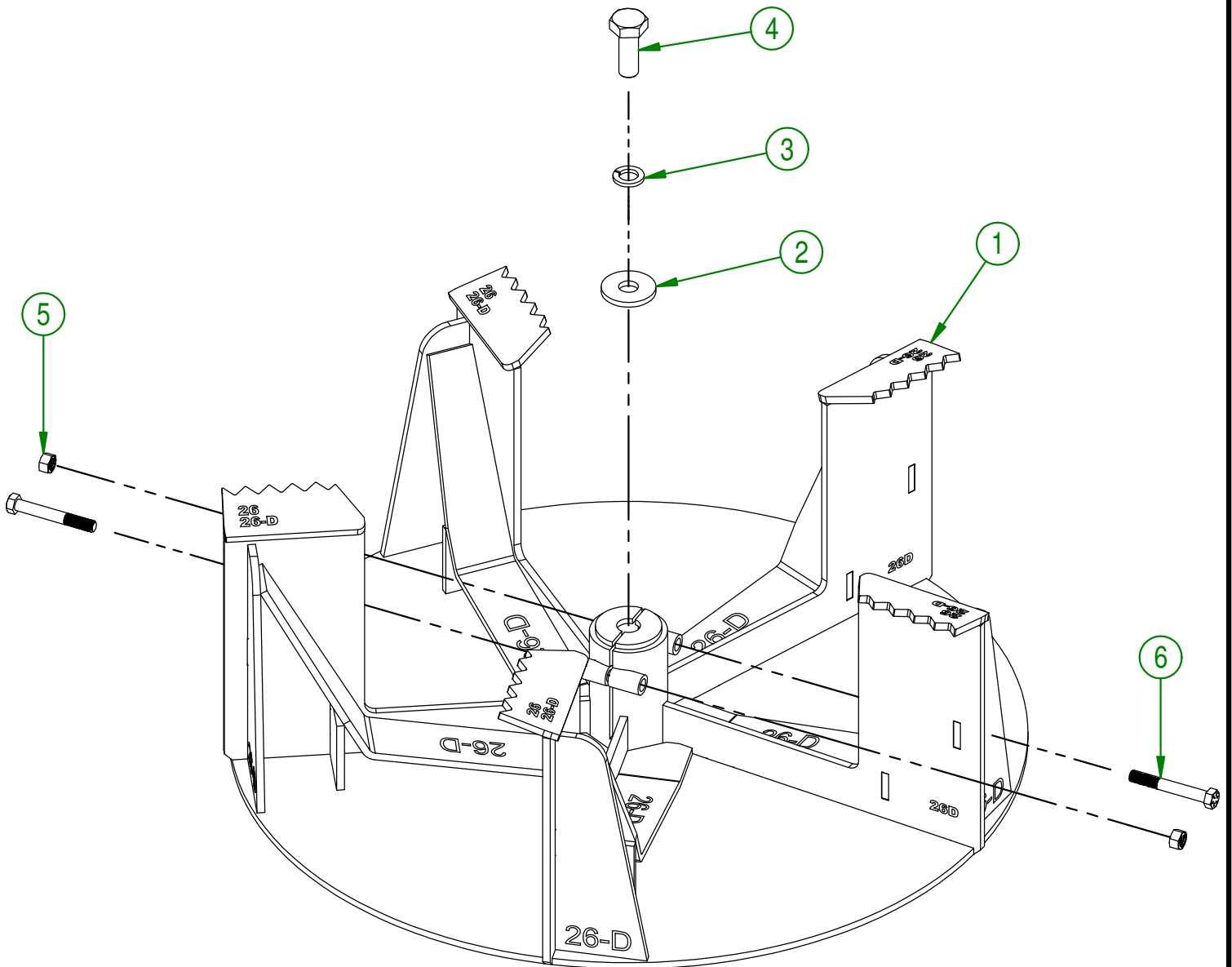

AGRIMETAL	
IMPELLER GROUP	
CREATION : 27/03/17	ASSEMBLY : 80-57-5426
REVISION : 25/06/20	AUTHOR : Dessin2 Page 14 de 23

80-57-5420

#	PART #	Qty	TITLE
1	80-50-5111	1	LEFT SNOW GUARD
2	80-50-5113	1	RIGHT SNOW GUARD
3	NC02-32-0014	6	LOCK WASHER ZINC 1/2"
4	NC01-25-0247	6	HEX. BOLT GR5 ZINC 1/2-13 X 1" LG

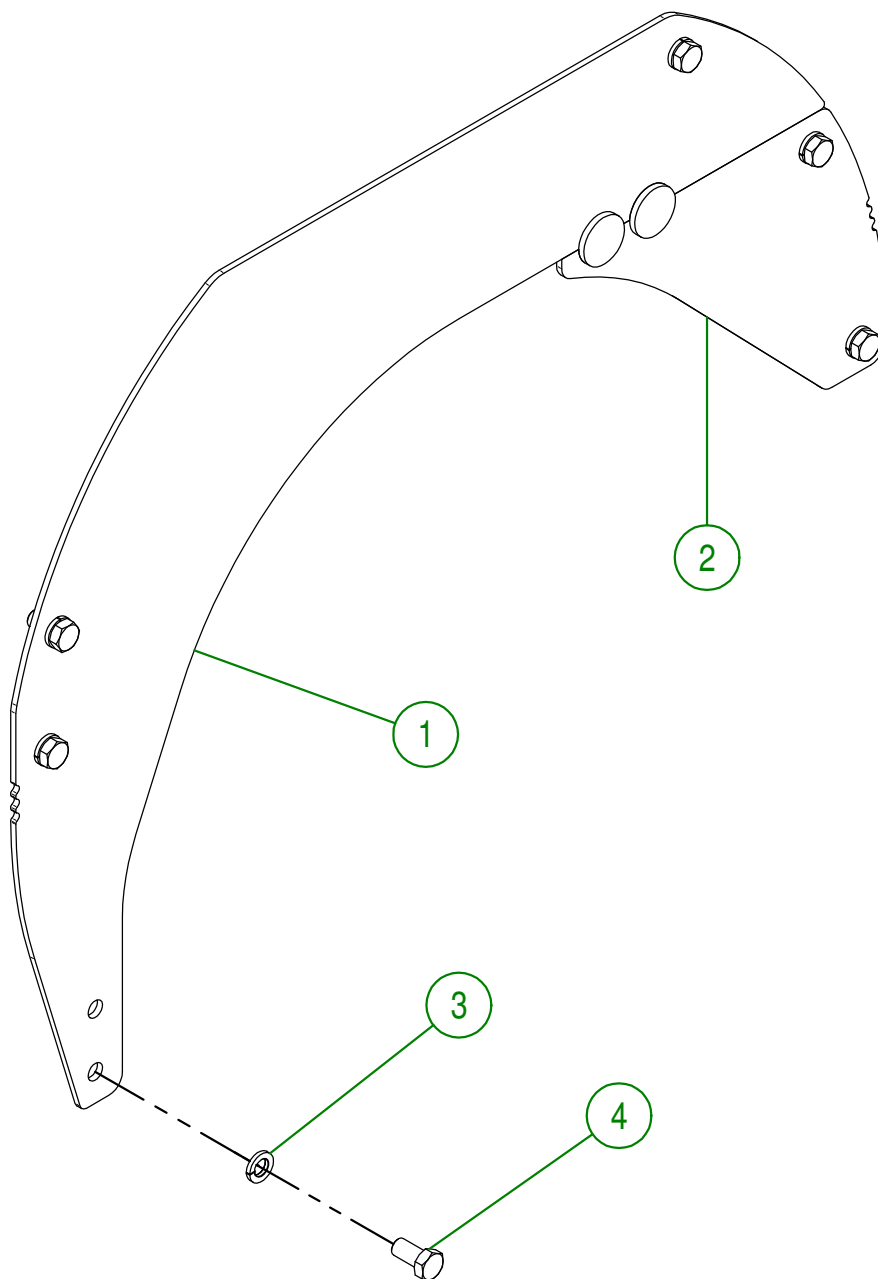

AGRIMETAL	
SNOW GUARD GROUP	
CREATION : 18/07/16	ASSEMBLY : 80-57-5420
REVISION : 04/04/18	AUTHOR : J. HOULE Page 15 de 23

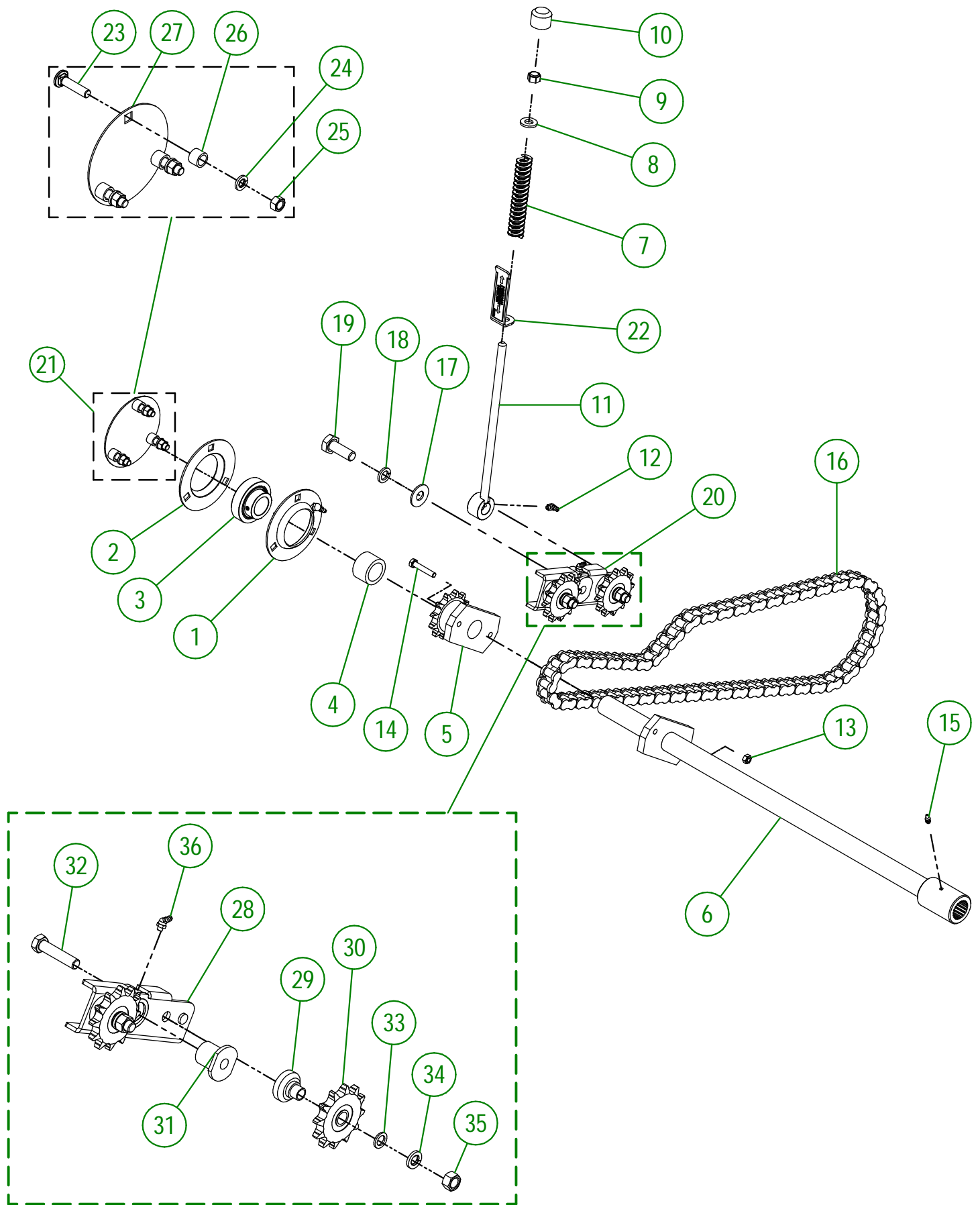

AGRIMETAL	
SPIRAL DRIVE TRAIN GROUP	
CREATION : 26/01/22	ASSEMBLY : 80-57-5935
REVISION : 13/04/23	AUTHOR : Dessin2

80-57-5935

#	PART #	Qty	TITLE
1	80-55-0030	1	PRESSED STEEL FLANGE WITH GREASE FITTING
2	NC14-75-0093	1	PRESSED STEEL FLANGE
3	NC14-75-0164	1	SB207-20 BEARING
4	80-21-0025	1	SPIRAL DRIVE TRAIN BUSHING
5	NC14-55-0293	1	60BI2H SPROCKET
6	80-50-0565	1	DRIVE TRAIN SPIRAL
7	NC13-86-0053	1	BLUE SPRING 1/2" ID X 1" OD X 6" LG
8	NC02-25-0011	1	WASHER SAE ZINC 17/32 ID
9	NC01-96-0014	1	NYLON-INSERT LOCKNUT ZINC 1/2-13
10	80-42-0110	1	THREADED ROD CAP
11	80-50-0040	1	THREADED ROD
12	NC01-69-0787	1	GREASE FITTING STRAIGHT 1/4-28 X 90
13	NC01-93-0010	1	LOCK NUT ZINC 5/16-18
14	NC01-17-0063	1	CAP SCREW GR2 NC ZINC 5/16-18 X 1 3/4"
15	NC01-69-0785	1	STRAIGHT GREASE FITTING 1/4-28
16	80-37-1010	1	#60 HD CHAIN
17	NC02-22-0013	1	WASHER ZINC 5/8 ID X 1 1/2 OD
18	NC02-32-0016	1	LOCK WASHER ZINC 5/8"
19	NC01-17-0395	1	HEX. BOLT GR2 ZINC 5/8-11 X 1 3/4"
20	80-55-0025	1	CHAIN TENSIONER GROUP
21	82-57-2950	1	BEARING GUARD GROUP.
22	80-57-0160	1	ADJUSTEMENT INDICATOR

82-57-2950

#	PART #	Qty	TITLE
23	NC01-04-0111	3	CARR. BOLT GR2 ZINC 3/8-16 X 1 1/2"
24	NC02-32-0012	3	LOCK WASHER ZINC 3/8"
25	NC02-07-0018	3	HEX. NUT ZINC 3/8-16
26	82-21-0000	3	BEARING BUSHING GUARD
27	82-01-7540	1	BEARING GUARD

80-55-0025

#	PART #	Qty	TITLE
28	80-50-0045	1	CHAIN TENSIONER
29	80-21-0020	2	CHAIN TENSIONER BUSHING (SPROCKET)
30	NC14-55-0295	2	SPROCKET 60A12H
31	80-13-2400	1	CHAIN TENSIONER BUSHING
32	NC01-29-0252	2	HEX. BOLT GR2 ZINC 1/2-20 X 2 1/4" LG
33	NC02-26-1100	2	WASHER SAE ZINC 17/32 ID X 13/16" OD
34	NC02-32-0014	2	LOCK WASHER ZINC 1/2"
35	NC02-10-0020	2	HEX. NUT ZINC 1/2-20
36	NC01-69-0786	1	GREASE FITTING 1/4-28 X 45

#	PART #	Qty	TITLE
1	01-01-2485	4	FLAT WASHER 14 GA X 13/16"OD X 25/64" ID
2	NC01-17-0114	2	HEX. BOLT GR2 ZINC 3/8-16 X 1"
3	NC01-96-0011	2	NYLON NUT 3/8-16
4	80-57-5036	1	CHAIN GUARD

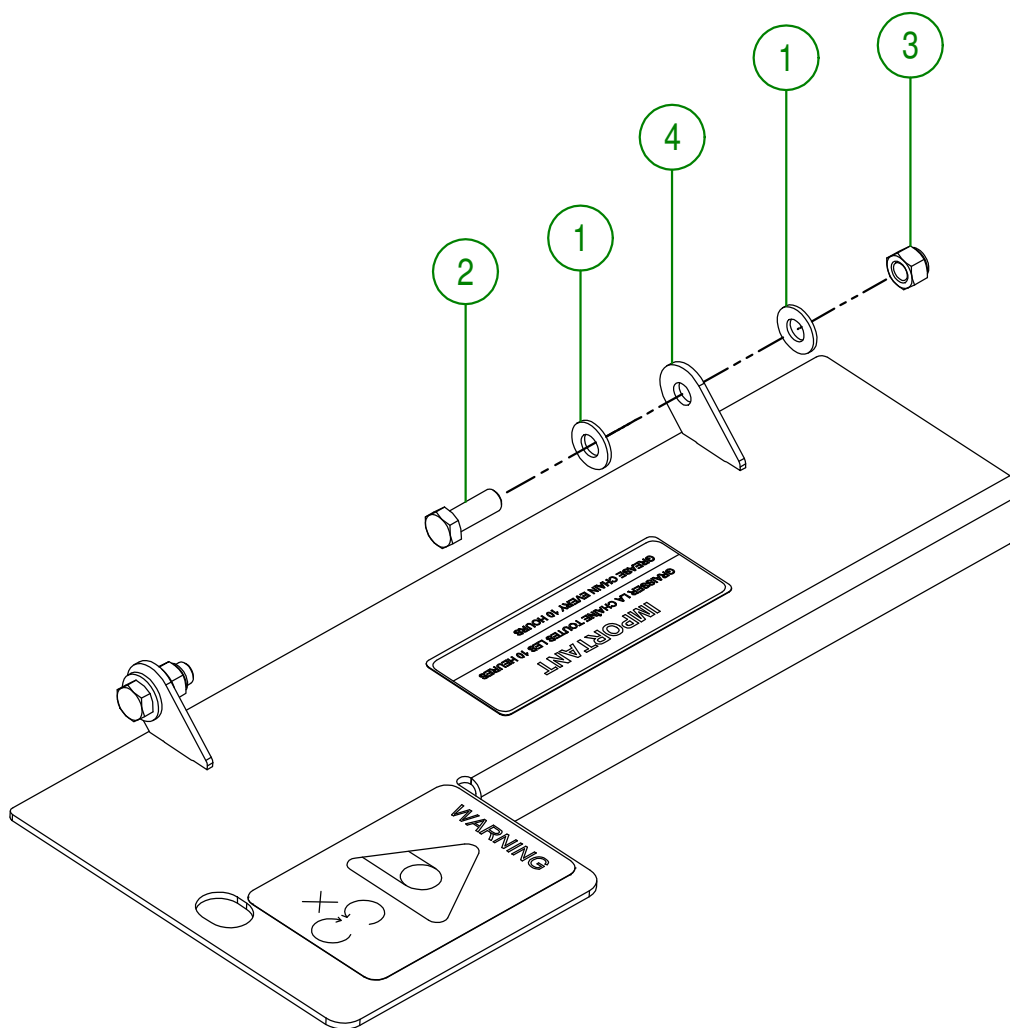

AGRIMETAL	
CHAIN GUARD GROUP	
CREATION : 18/07/16	ASSEMBLY : 80-57-5445
REVISION : 18/11/19	AUTHOR : J. HOULE Page 20 de 23

80-57-0915

#	PART #	Qty	TITLE
1	NC01-17-0250	8	HEX. BOLT GR2 ZINC 1/2-13 X 1 3/4"
2	NC02-25-0011	8	WASHER SAE ZINC 17/32 ID
3	NC02-32-0014	8	LOCK WASHER ZINC 1/2"
4	NC02-07-0020	8	HEX. NUT ZINC 1/2-13
5	80-50-0580	1	SPIRAL
6	NC14-75-0160	2	FLANGE BEARING UCF207-20 1 1/4" ID
8	NC14-55-0294	1	60A32H SPROCKET
9	NC01-29-0115	4	HEX. BOLT GR5 ZINC 3/8-24 X 1 1/4" LG
10	NC01-94-0011	4	LOCK NUT 3/8-24
11	80-51-0140	1	(LEFT) PRE-ASSEMBLE SPIRAL SHAFT
12	80-51-0091	1	(RIGHT) PRE-ASSEMBLE SPIRAL SHAFT

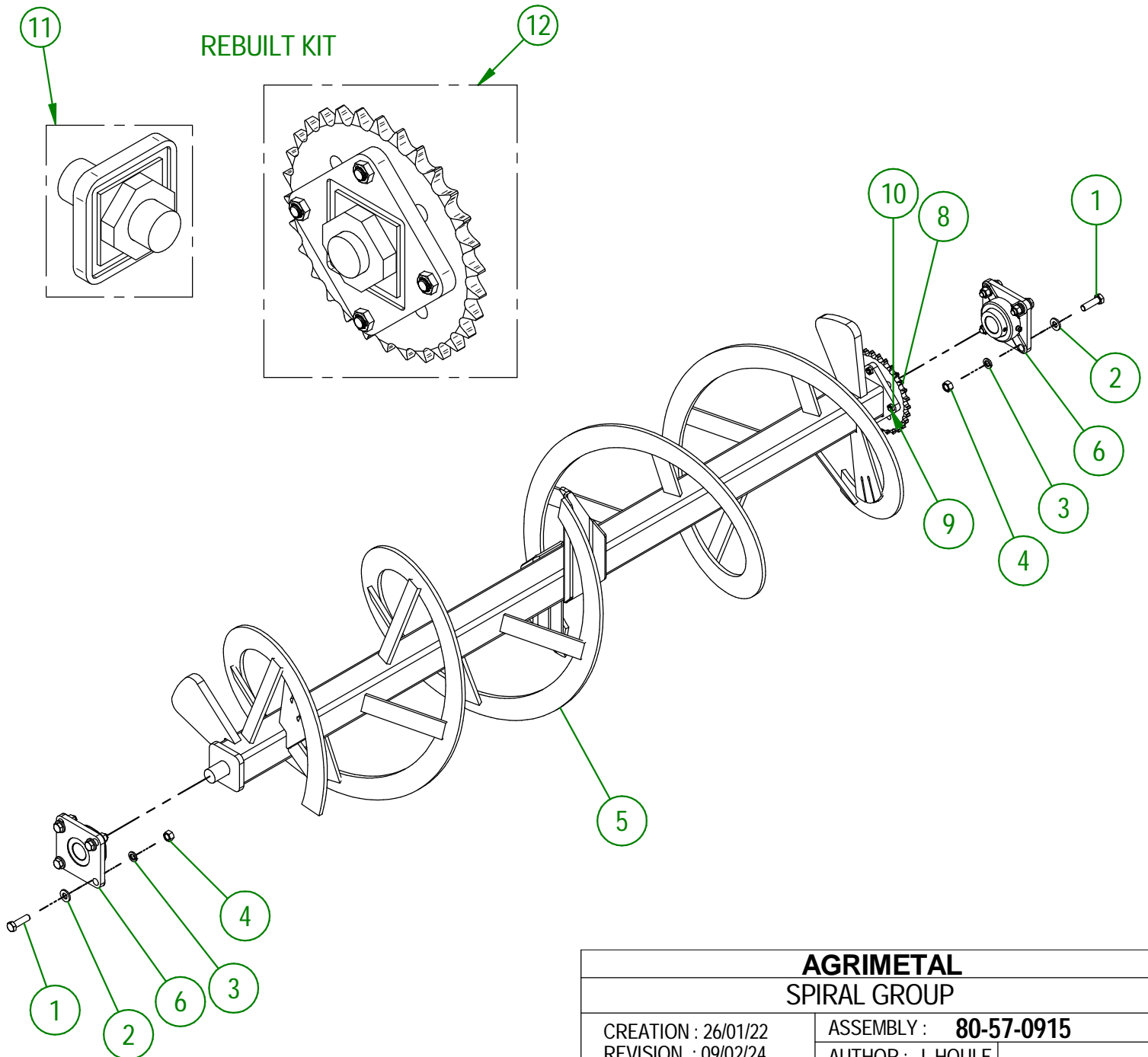

AGRIMETAL
SPIRAL GROUP

CREATION : 26/01/22
REVISION : 09/02/24

ASSEMBLY : **80-57-0915**
AUTHOR : J. HOULE

#	PART #	Qty	TITLE
1	80-50-5070	1	CHAIN GUARD
2	NC01-04-0107	4	CARR. BOLT GR2 ZINC 3/8-16 X 3/4"
3	NC02-14-0019	4	FLANGE NUT HEX. NC 3/8-16 GR. B

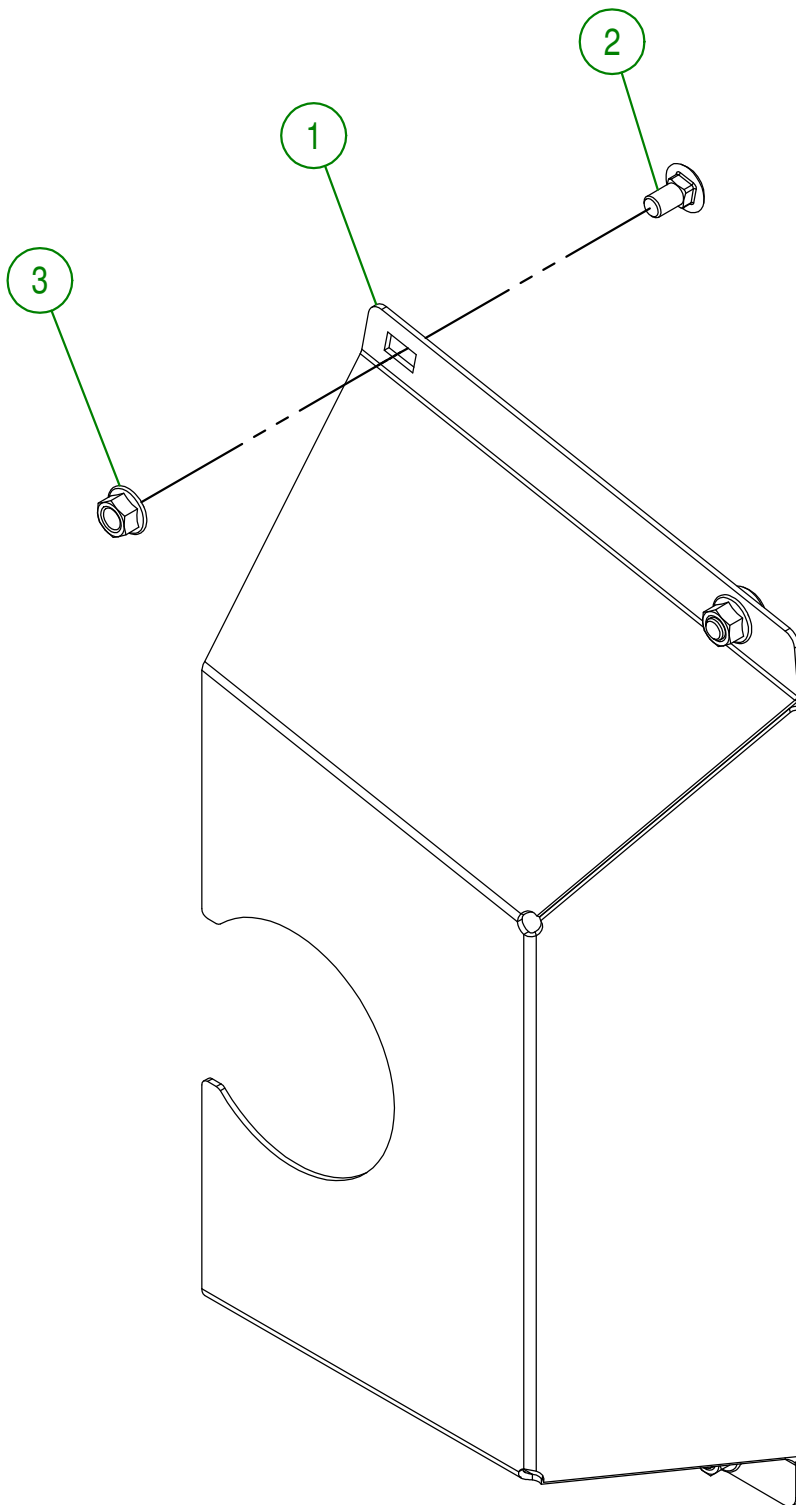

AGRIMETAL	
SPIRAL CHAIN GUARD GROUP	
CREATION : 18/07/16	ASSEMBLY : 80-57-5405
REVISION : 04/04/18	AUTHOR : J. HOULE Page 19 de 23

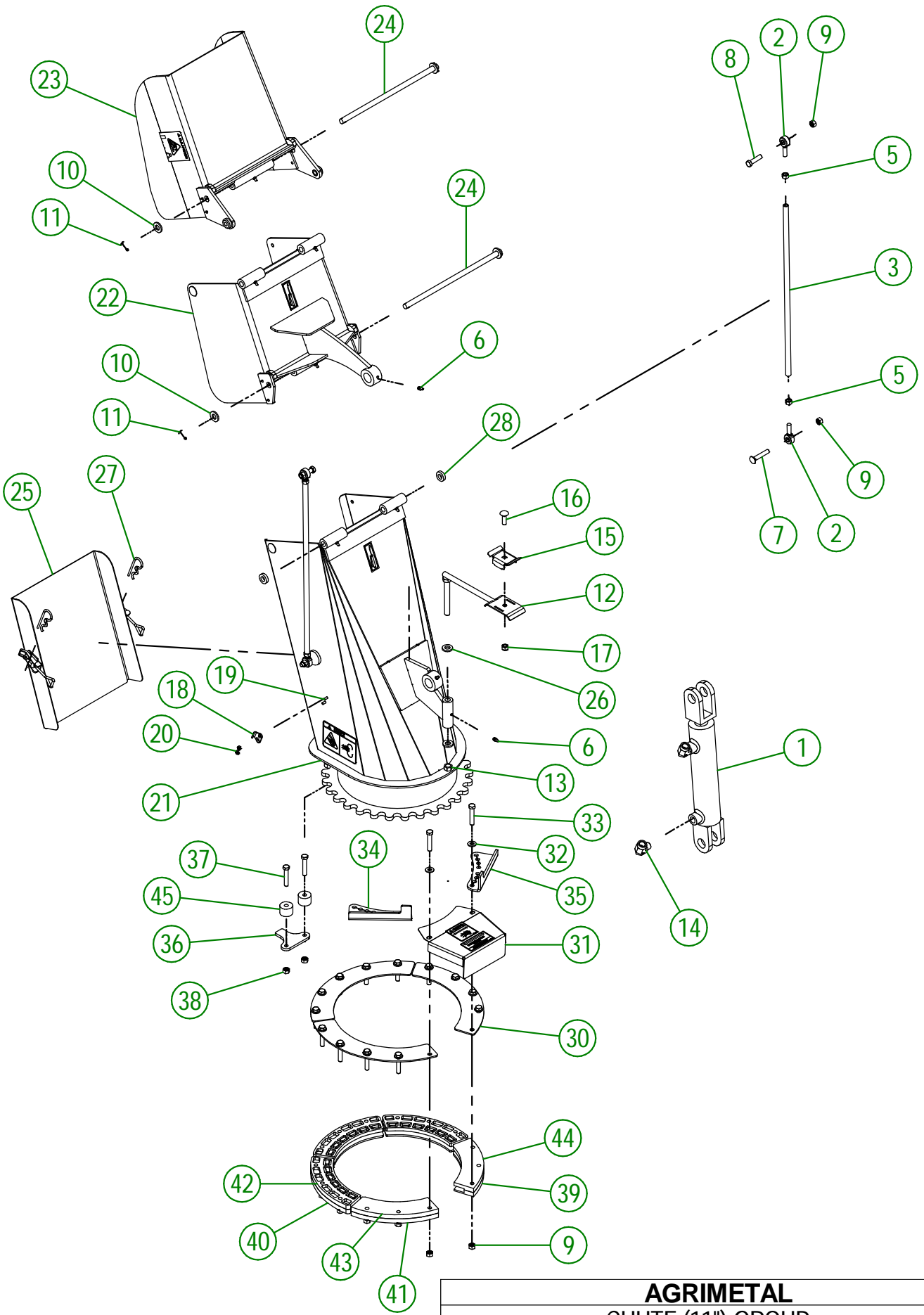

AGRIMETAL
CHUTE (11'') GROUP

CREATION : 20/01/22
 REVISION : 20/01/22

ASSEMBLY : **80-57-5735**
 AUTHOR : J. Houle

80-57-5735

#	PART #	QTY	TITLE
1	NC13-45-0209	1	HYDRAULIC CYLINDER 6"
2	NC01-67-0304	4	ROD END 3/8-24
3	48-13-0600	2	CHUTE ROD (DOUBLE)
4*	NC01-67-0304	4	ROD END 3/8-24
5	NC02-10-0018	4	NUT 3/8-24
6	NC01-69-0785	9	STRAIGHT GREASE FITTING 1/4-28
7	NC01-07-0113	2	CARR. BOLT GR5 ZINC 3/8-16 X 2" LG
8	NC01-25-0116	2	HEX. BOLT GR5 ZINC 3/8-16 X 1 1/2"
9	NC01-93-0011	19	LOCK NUT 3/8-16
10	NC02-25-0011	4	WASHER SAE ZINC 17/32 ID
11	NC01-69-0139	4	COTTER PIN ZINC 1/8" X 3/4"
12	82-50-5030	1	HYDRAULIC HOSE SUPPORT
13	NC01-96-0014	1	NYLON-INSERT LOCKNUT ZINC 1/2-13
14	NC13-45-0038	2	ELBOW 90 3/8 FEM. NPT X 3/8 MALE NPT
15	48-01-7530	1	HYDRAULIC HOSE SUPPORT
16	NC01-04-0110	1	CARR. BOLT GR2 ZINC 3/8-16 X 1 1/4"
17	NC01-96-0011	1	NYLON NUT 3/8-16
18	NC01-63-0052	2	ADJUSTABLE LATCH (STRIKE)
19	NC02-40-0080	4	MACHINE SCREWS SQUARE SOCKET #10-24 X 1/2" LG
20	NC01-96-0006	4	NYLON NUT ZINC 10-24
21	80-57-5301	1	CHUTE (BOTTOM SECTION)
22	80-57-5310	1	CHUTE (MIDDLE SECTION)
23	80-57-5320	1	CHUTE (TOP SECTION)
24	80-20-0255	2	PIVOT
25	80-57-5352	1	CHUTE DOOR
26	01-01-0925	2	WASHER
27	NC01-63-0026	2	COTTER PIN ZC 5/32" X 3"
28	NC13-15-0334	2	PIVOT WASHER
29	46-01-0960	1	BRACE
30	46-01-0955	2	BRACE
31	80-57-0550	1	SPROCKET GUARD GROUP "STICKER INCLUDED"
32	01-01-2485	15	FLAT WASHER 14 GA X 13/16"OD X 25/64" ID
33	NC01-17-0118	15	HEX. BOLT GR2 ZINC 3/8-16 X 2"
34	84-04-0180	1	ADJUSTABLE STOPPER
35	84-04-0183	1	ADJUSTABLE STOPPER
36	84-04-0170	1	STOPPER
37	NC01-37-0118	2	HEX. BOLT GR8 ZINC 3/8-24 X 2"
38	NC01-94-0011	2	LOCK NUT 3/8-24
39	46-42-0107	1	CHUTE GUIDE (UNDER)
40	NC17-46-0030	3	CHUTE GUIDE (UNDER)
41	46-42-0106	1	CHUTE GUIDE (UNDER)
42	NC17-46-0029	3	CHUTE GUIDE (TOP)
43	46-42-0101	1	CHUTE GUIDE (TOP)
44	46-42-0102	1	CHUTE GUIDE (TOP)
45	81-21-0040	2	ADJUSTABLE STOPPER SPACER

#	PART #	Qty	TITLE
1	NC14-45-0156	1	HYDRAULIC MOTOR
2	48-50-1025	1	HYDRAULIC ENGINE SPROCKET
3	NC02-32-0012	4	LOCK WASHER ZINC 3/8"
4	NC01-17-0112	4	HEX. BOLT GR2 ZINC 3/8-16 X 3/4"
5	NC02-32-0010	1	LOCK WASHER ZINC 1/4"
6	NC01-33-0005	1	HEX. BOLT GR8 ZINC 1/4-20 X 7/8"
7	NC17-46-0031	1	HYDRAULIC MOTOR BUSHING
8	NC02-22-0009	1	WASHER
9	NC02-44-0103	2	SET SCREW 5/16-18 X 3/8"
10	NC13-45-0073	2	STRAIGHT 7/8-14 MALE SAE10 O-RING X 3/8 FEM. TOUR. NPT

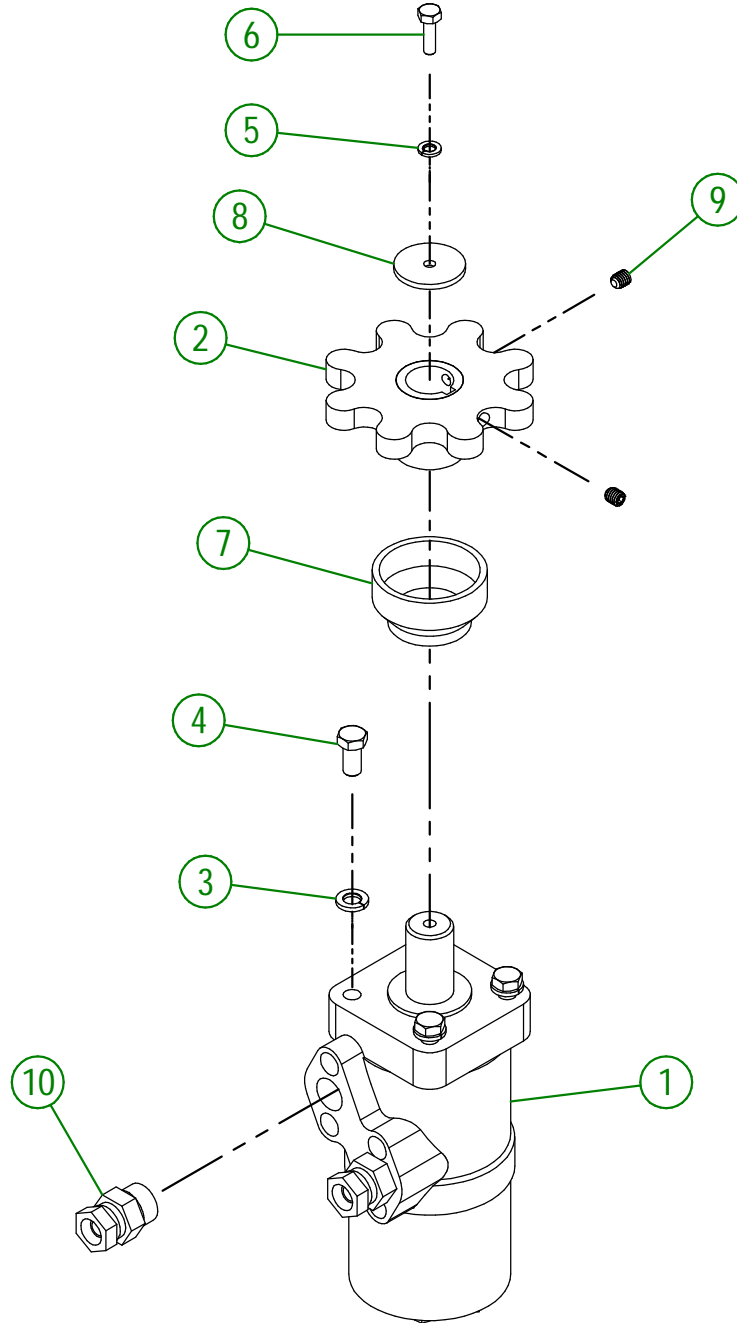

AGRIMETAL

HYDRAULIC MOTOR GROUP

CREATION : 26/01/22
REVISION : 03/03/23

ASSEMBLY : **80-57-5725**
AUTHOR : J. Houle

#	PART #	Qty	TITLE
1	NCI3-45-0047	6	QUICK COUPLER NPTF 1/2-14
2	NCI3-45-0384	6	1/2 FIXABLE RIGHT UNION
3	NCI7-02-0433	1	3/8 HYDRAULIC HOSE 80"LG
4	NCI7-02-0433	1	3/8 HYDRAULIC HOSE 80"LG
5	NCI7-02-0431	1	3/8 HYDRAULIC HOSE 27"LG
6	NCI7-02-0431	1	3/8 HYDRAULIC HOSE 27"LG
7	NCI3-45-0038	1	ELBOW 90 3/8 FEM. NPT X 3/8 MALE NPT
8	NCI3-45-0386	1	T 3/8 MÂLE NPT X 3/8 MÂLE NPT X 3/8 FEM NPT
9	NCI3-45-0385	1	T 3/8 MALE NPT X 3/8 FEM. NPT X 3/8 MALE NPT
10	NCI7-02-0430	1	3/8 HYDRAULIC HOSE 25"LG
11	NCI7-02-0432	1	3/8 HYDRAULIC HOSE 36"LG
12	NCI7-02-0429	1	3/8 HYDRAULIC HOSE 16"LG
13	NCI7-02-0431	1	3/8 HYDRAULIC HOSE 27"LG
14	NCI3-45-0153	6	HEX. REDUCER 1/4 NPT X 1/2 NPT
15	NCI3-45-0369	6	QUICK COUPLER 1/2-14 NPTF

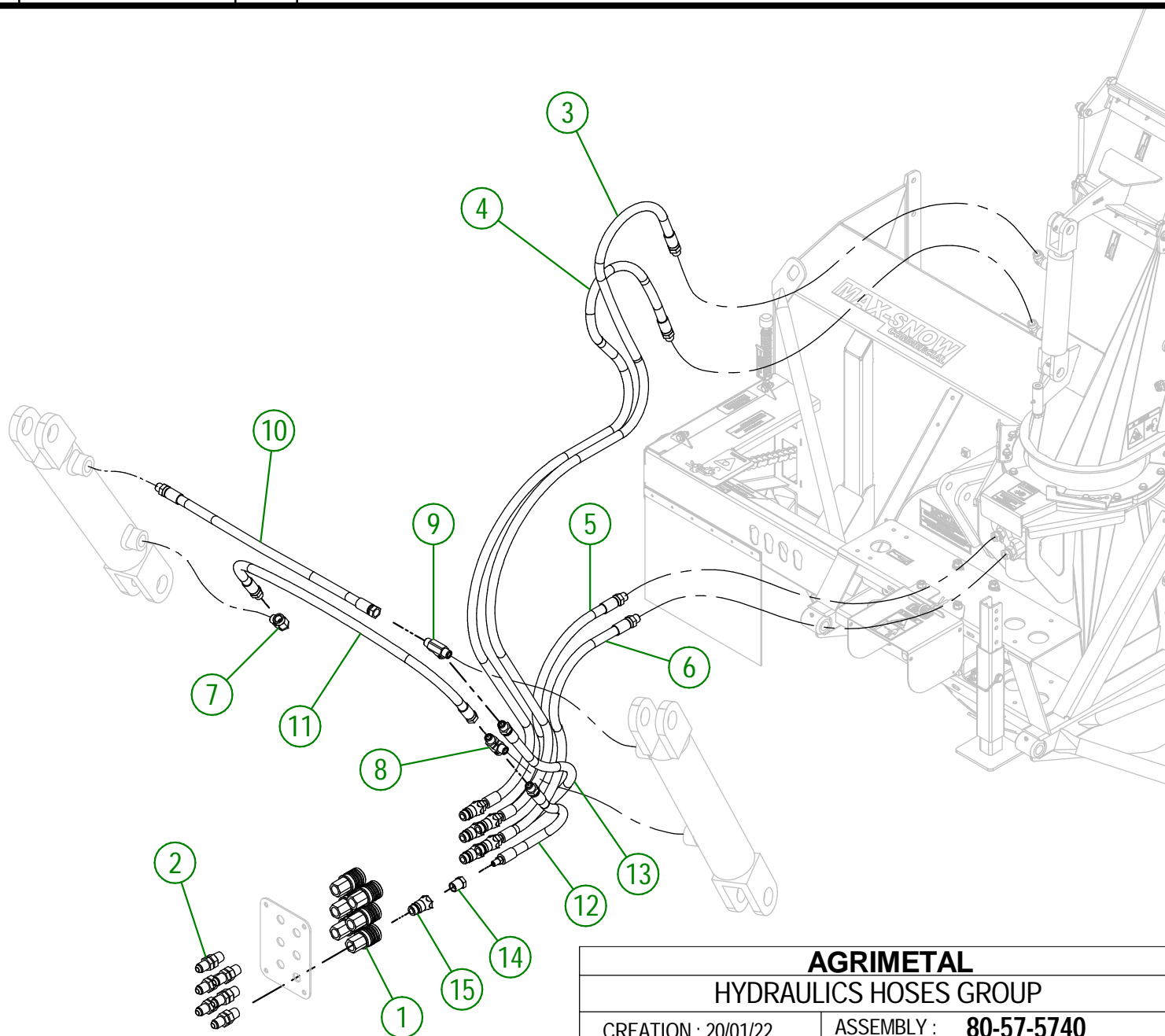

AGRIMETAL	
HYDRAULICS HOSES GROUP	
CREATION : 20/01/22	ASSEMBLY : 80-57-5740
REVISION : 20/01/22	AUTHOR : J. Houle

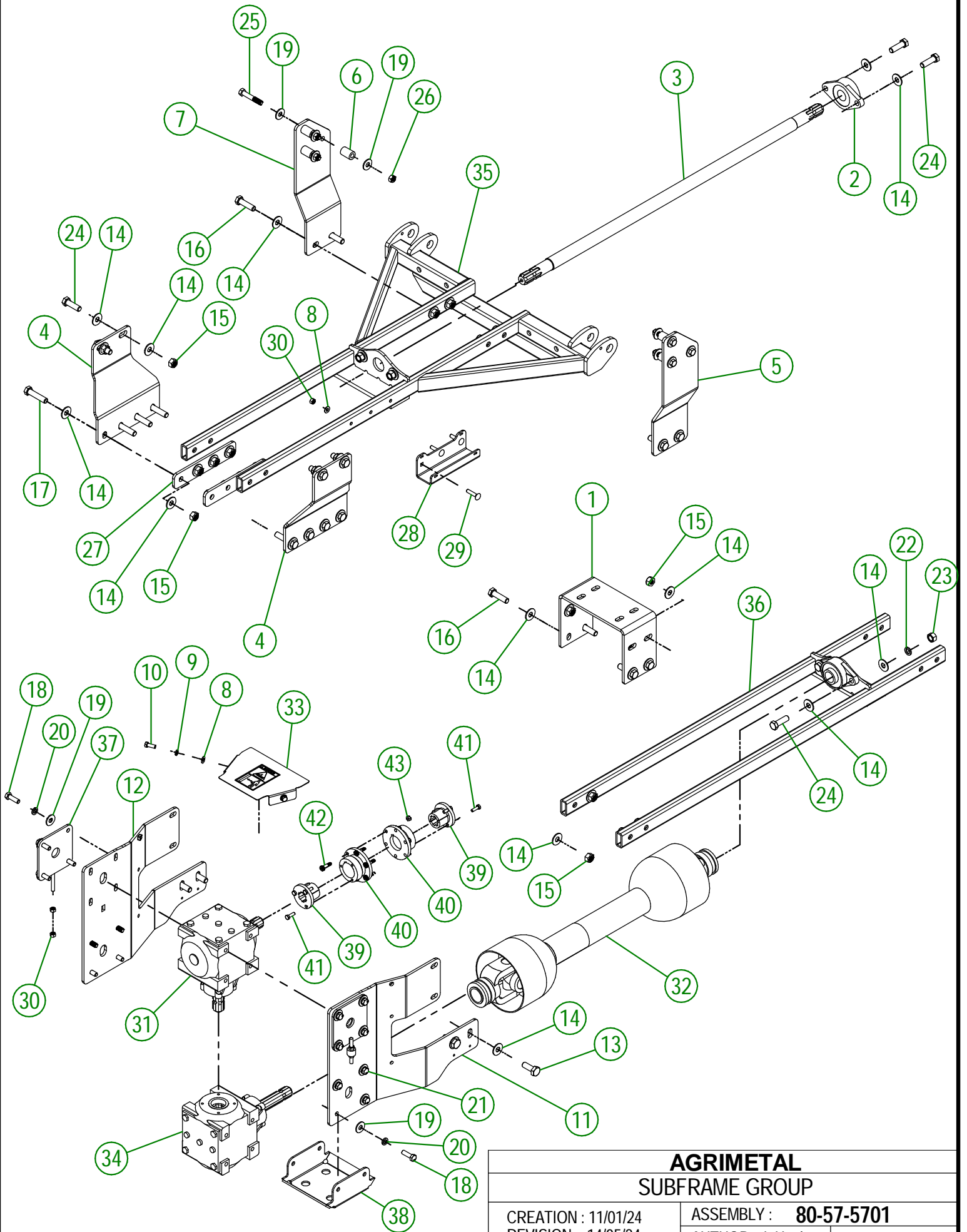

**AGRIMETAL
SUBFRAME GROUP**

CREATION : 11/01/24
REVISION : 14/05/24

ASSEMBLY : **80-57-5701**
AUTHOR : J. Houle

80-57-5701

#	PART #	Qty	TITLE
1	80-04-0766	1	REAR FRAME HOLDER
2	NC14-75-0149	2	BEARING UCFL207-22 I 3/8"
3	80-20-0091	1	SHAFT
4	80-04-0776	2	MIDDLE FRAME HOLDER
5	80-04-0781	1	RIGHT FRAME HOLDER
6	80-13-0115	6	SPACER FOR FRAME HOLDER
7	80-04-0784	1	LEFT FRAME HOLDER
8	01-01-2485	5	FLAT WASHER 14 GA X 13/16"OD X 25/64" ID
9	NC02-32-0012	2	LOCK WASHER ZINC 3/8"
10	NC01-17-0114	2	HEX. BOLT GR2 ZINC 3/8-16 X 1"
11	80-50-5735	1	RIGHT GEARBOX HOLDER
12	80-50-5740	1	LEFT GEARBOX HOLDER
13	NC01-33-0395	4	HEX. BOLT GR8 ZINC 5/8-11 X 1 3/4"
14	NC02-22-0013	56	WASHER ZINC 5/8 ID X 1 1/2 OD
15	NC01-93-0016	24	LOCK NUT ZINC 5/8-11
16	NC01-33-0397	8	HEX. BOLT GR8 NC ZINC 5/8-11 X 2 1/4"
17	NC01-33-0399	8	HEX. BOLT GR8 NC ZINC 5/8-11 X 2 1/2"
18	NC01-45-0259	12	GR8.8 METR. BOLT 12MM X 1.75 PITCH X 40MM
19	NC02-22-0012	28	WASHER ZINC 1/2 BOLT = 9/16"Ø X 1 3/8" OD
20	NC02-32-0014	16	LOCK WASHER ZINC 1/2"
21	NC01-45-0258	4	GR8.8 METR. BOLT 12MM X 1.75 PITCH X 35MM
22	NC02-32-0016	4	LOCK WASHER ZINC 5/8"
23	NC02-07-0022	4	HEX. NUT ZINC 5/8-11
24	NC01-33-0396	8	HEX. BOLT GR8 ZINC 5/8-11 X 2"
25	NC01-33-0255	6	HEX. BOLT GR8 ZINC 1/2-13 X 3"
26	NC01-93-0014	6	LOCK NUT ZINC 1/2-13
27	80-04-1100	2	FRAME UNION
28	80-04-1105	1	HYDRAULIC HOSE HOLDER
29	NC01-04-0112	3	CARR. BOLT GR2 ZINC 3/8-16 X 1 3/4"
30	NC01-93-0011	7	LOCK NUT 3/8-16
31	80-34-0105	1	GEARBOX T27D 9.267.370.00 RATIO 1:1.12
32	32-34-0030	1	PTO SHAFT
33	80-57-5745	1	PTO GUARD
34	80-34-0110	1	GEARBOX T27D 9.267.534.00 RATIO 1:1 HOLLOW SHAFT
35	80-57-5751	1	FRONT FRAME
36	80-57-5755	1	REAR FRAME
37	80-50-5760	2	ADJUSTMENT PLATE
38	80-50-5765	1	GEARBOX GUARD
39	NC14-62-0237	2	PI X I 3/8 6B SPLINE BORE BUSHING
40	82-13-0020	2	PTO UNION
41	NC01-17-0060	6	HEX. BOLT GR2 ZINC 5/16-18 X 1"
42	NC01-62-0004	6	SHOULDER BOLT 3/8 X 3/4 5/16-18 THREAD
43	NC01-93-0010	6	LOCK NUT ZINC 5/16-18

#	PART #	TITLE	Qty
1	80-57-5760	FRONT ATTACHMENT ARMS	2
2	NC13-45-0209	HYDRAULIC CYLINDER 6"	2
3	80-50-5711	FRONT ATTACHMENT	1
4	NC01-69-0785	STRAIGHT GREASE FITTING 1/4-28	6
5	80-50-5745	FRONT ATTACHMENT PIN	2
6	48-20-0060	3 POINT PIN	2
7	48-20-0075	3 POINT PIN	2
8	NC01-69-1100	LINCH PIN 3/8"	6
9	NC02-22-0013	WASHER ZINC 5/8 ID X 1 1/2 OD	8
10	NC01-33-0404	HEX. BOLT GR8 ZINC 5/8-11 X 4" LG	4
11	NC01-93-0016	LOCK NUT ZINC 5/8-11	4
12	NC02-22-0012	WASHER ZINC 1/2 BOLT = 9/16"Ø X 1 3/8" OD	12
13	NC01-33-0251	HEX. BOLT GR8 NC ZINC 1/2-13 X 2"	6
14	NC02-22-0008	WASHER ZINC 5/16"	4
15	NC01-17-0061	HEX. BOLT GR2 ZINC 5/16-18 X 1 1/4"	2
16	NC02-32-0011	LOCK WASHER ZINC 5/16"	2
17	NC02-07-0017	HEX. NUT 5/16-18	2
18	NC01-96-0014	NYLON-INSERT LOCKNUT ZINC 1/2-13	6
19	80-01-2040	HYDRAULIC HOSE GUIDE	1
20	NC01-17-0116	HEX. BOLT GR2 ZINC 3/8-16 X 1 1/2"	4
21	01-01-2485	FLAT WASHER 14 GA X 13/16"OD X 25/64" ID	4
22	NC02-32-0012	LOCK WASHER ZINC 3/8"	4
23	NC02-07-0018	HEX. NUT ZINC 3/8-16	4

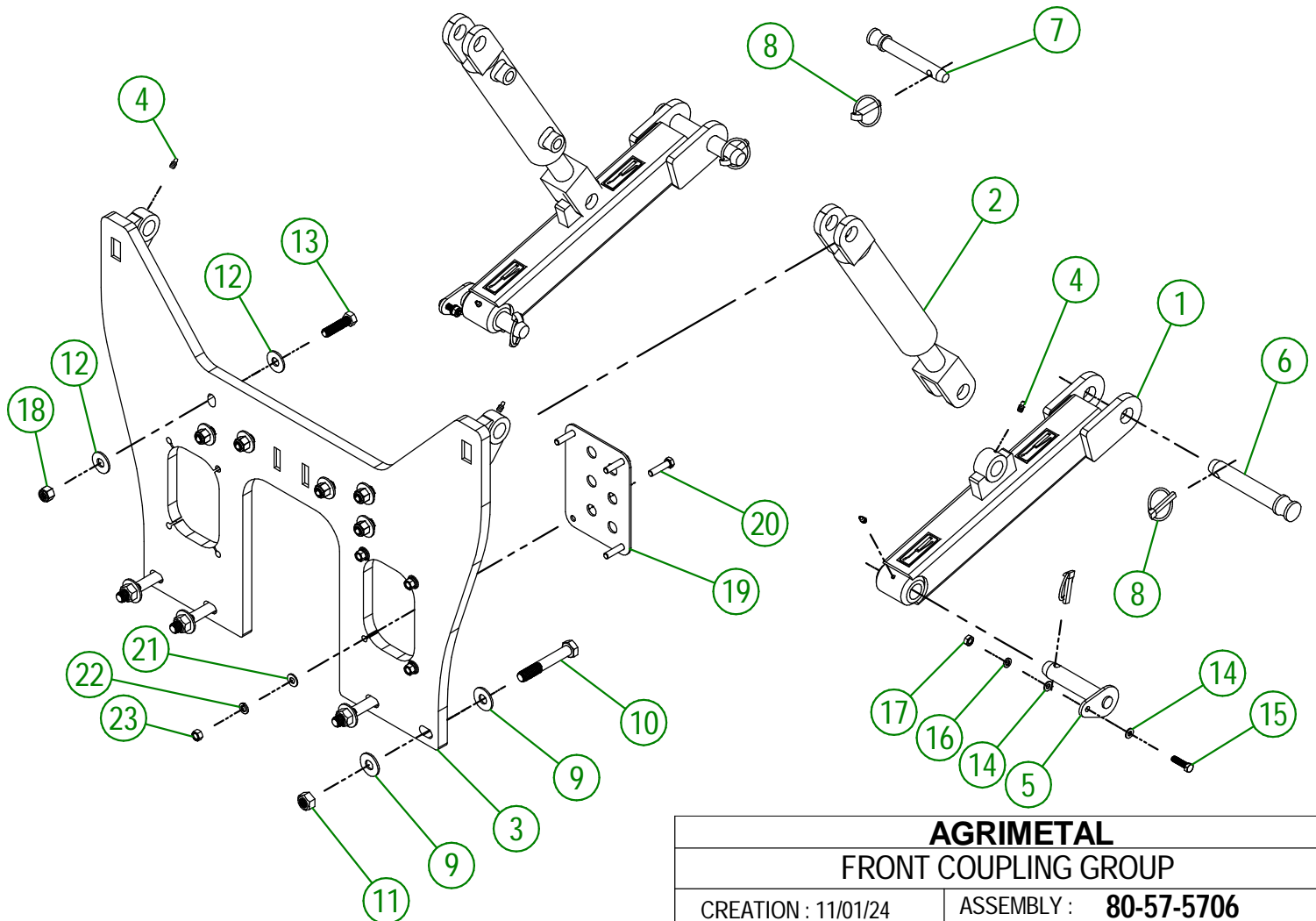

AGRIMETAL
FRONT COUPLING GROUP

CREATION : 11/01/24
REVISION : 11/01/24

ASSEMBLY : **80-57-5706**
AUTHOR : D. CHASSÉ

#	PART #	Qty	TITLE
1	NCI3-30-0237	1	PLASTIC TUBE FOR OPERATOR'S MANUAL
2	NC02-22-0008	2	WASHER ZINC 5/16"
3	NC01-17-0007	2	HEX. BOLT GR2 ZINC 1/4-20 X 1 1/4"
4	NC01-96-0009	2	NYLON-INSERT LOCKNUT ZINC 1/4-20
5	80-57-0030	1	SET OF 6 SHEAR BOLT WITH NUT
6	80-98-0522	1	ENGLISH OPERATOR'S MANUAL (MS26, 26-D, 24-D)

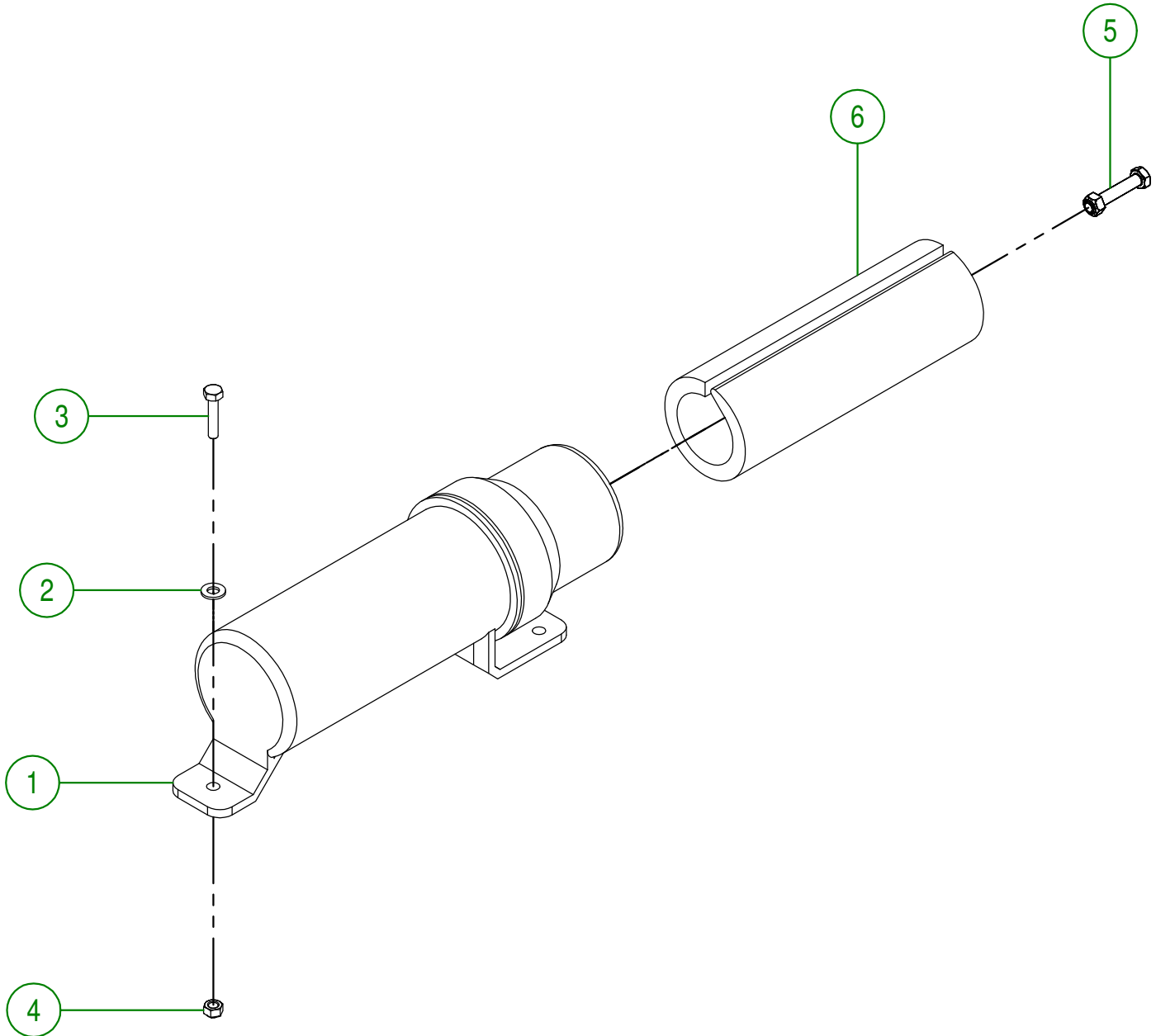
**AGRIMETAL****OPERATOR'S MANUAL TUBE GROUP**

CREATION : 18/07/16
 REVISION : 08/05/18

ASSEMBLY : **80-57-0400**

AUTHOR : J. HOULE | Page 21 de 23

#	PART #	Qty	TITLE
1	48-05-2105	2	LATERAL CUTTER BLADES
2	NC01-25-0248	4	HEX. BOLT GR5 ZINC 1/2-13 X 1 1/4"
3	NC02-32-0014	4	LOCK WASHER ZINC 1/2"
4	NC02-07-0020	4	HEX. NUT ZINC 1/2-13

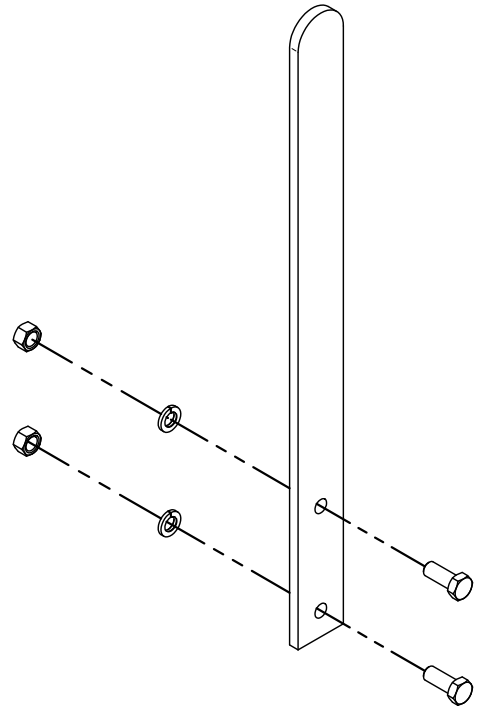
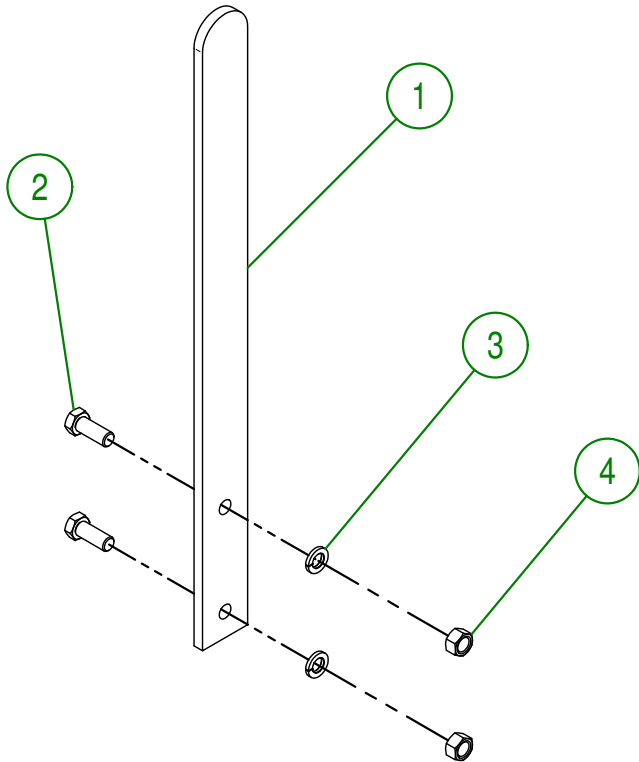

AGRIMETAL	
LATERAL CUTTER BLADES	
CREATION : 24/11/17	ASSEMBLY : 48-57-1235
REVISION : 22/10/18	AUTHOR : J. Houle Page 4 de 23

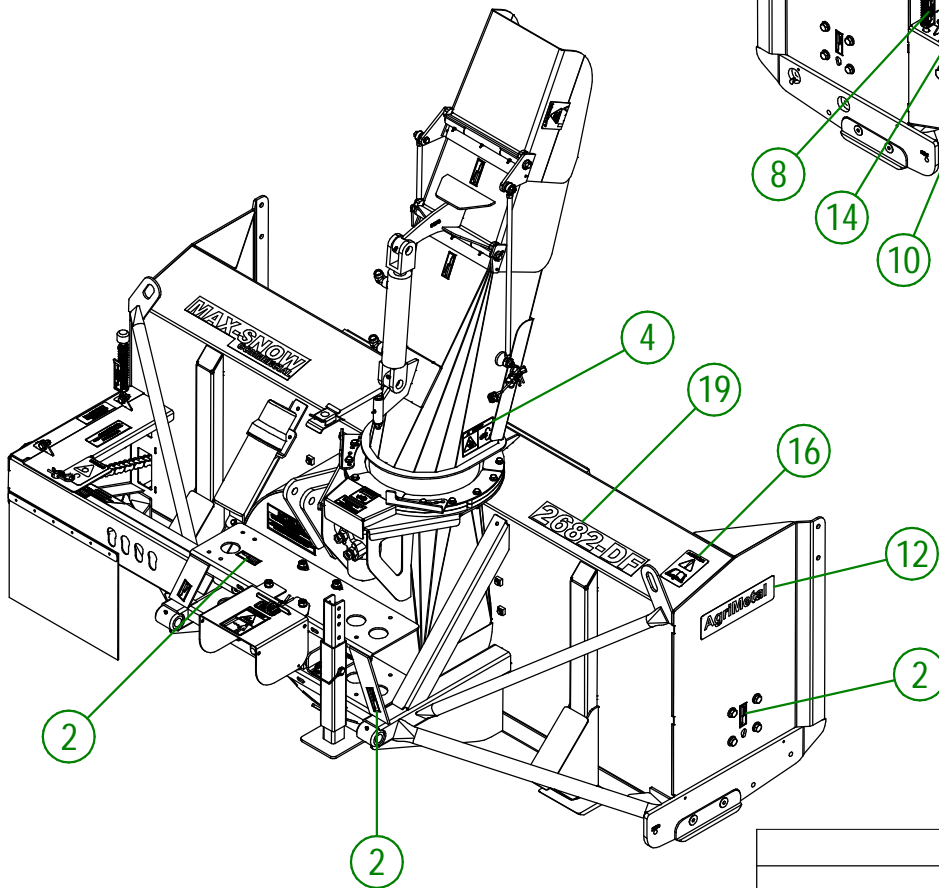
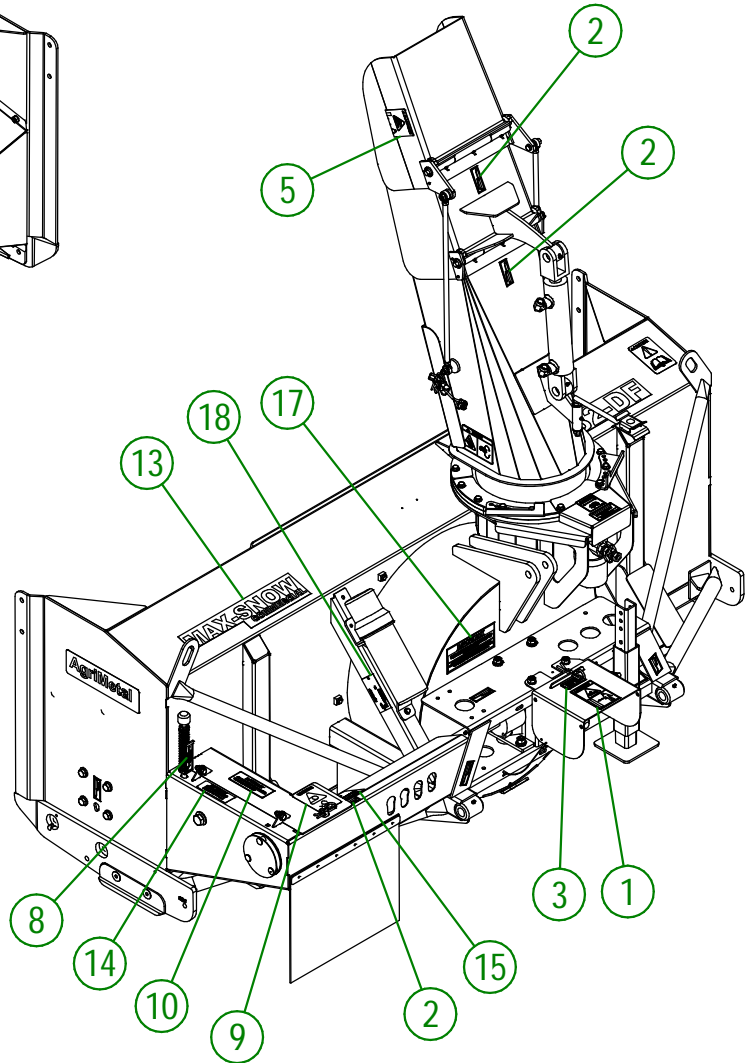
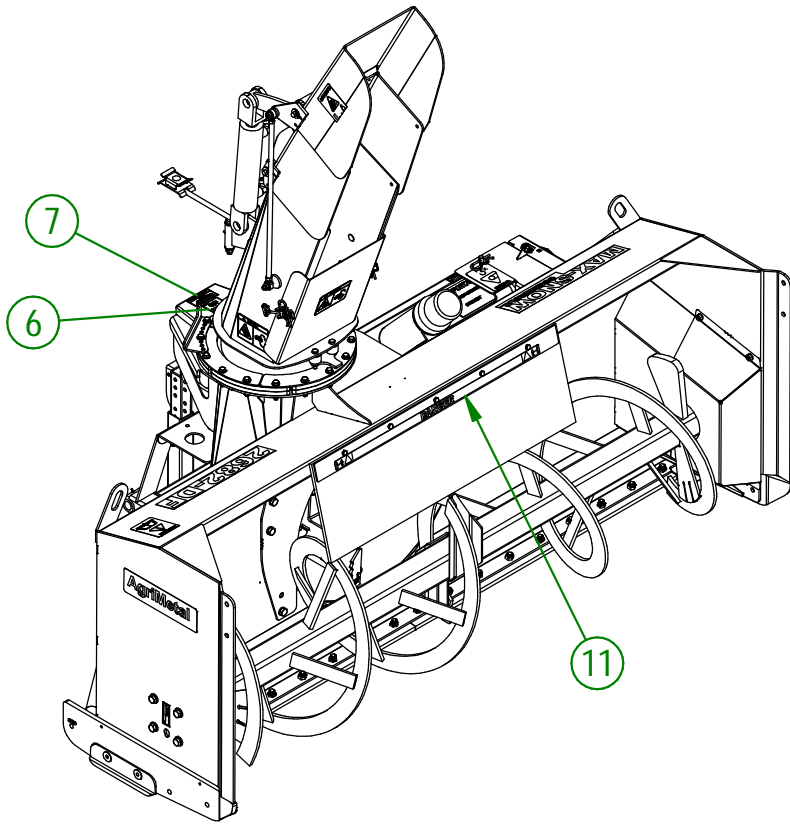

AGRIMETAL
MS2682-DF-JD

CREATION : 24/01/22
REVISION : 24/01/22

ASSEMBLY : **80-99-5700**
AUTHOR : J. Houle

80-99-5700

#	PART #	QTY	TITLE
1	NCI3-33-0187	2	STICKER DANGER (PTO AND PERSON)
2	NCI3-33-0024	14	STICKER GREASE HERE
3	NCI3-33-0005	1	STICKER MAXIMUM 540 RPM
4	NCI3-33-0249	3	STICKER DANGER
5	NCI3-33-0192	2	STICKER (PROJECTION RISK)
6	NCI3-33-0326	1	STICKER DANGER (HAND)
7	NCI3-33-0327	1	STICKER END ROTATION ADJUSTMENT
8	NCI3-33-0344	1	ADJUSTMENT INDICATOR STICKER
9	NCI3-33-0283	1	STICKER DANGER (PERSON AND CHAIN DRIVE)
10	NCI3-33-0343	1	GREASE CHAIN EVERY 10 HOURS STICKER
11	NCI3-33-0274	1	STICKER DANGER
12	NCI3-33-0035	2	STICKER AGRIMETAL
13	NCI3-33-0241	1	STICKER MAX-SNOW COMMERCIAL
14	NCI3-33-0104	1	STICKER IMPORTANT 4 INCHES 100 MM
15	NCI3-33-0280	1	STICKER SHEAR BOLT
16	NCI3-33-0183	1	STICKER CAUTION OPERATION MANUAL
17	NCI3-33-0317	1	STICKER GREASE DRIVE LINE TELESCOPIC SHAFT
18	NCI3-50-0086	1	SERIAL NUMBER PLATE
19	NCI3-33-2657	1	STICKER 2682-DF

