

# AgriMetal

## PARTS LIST

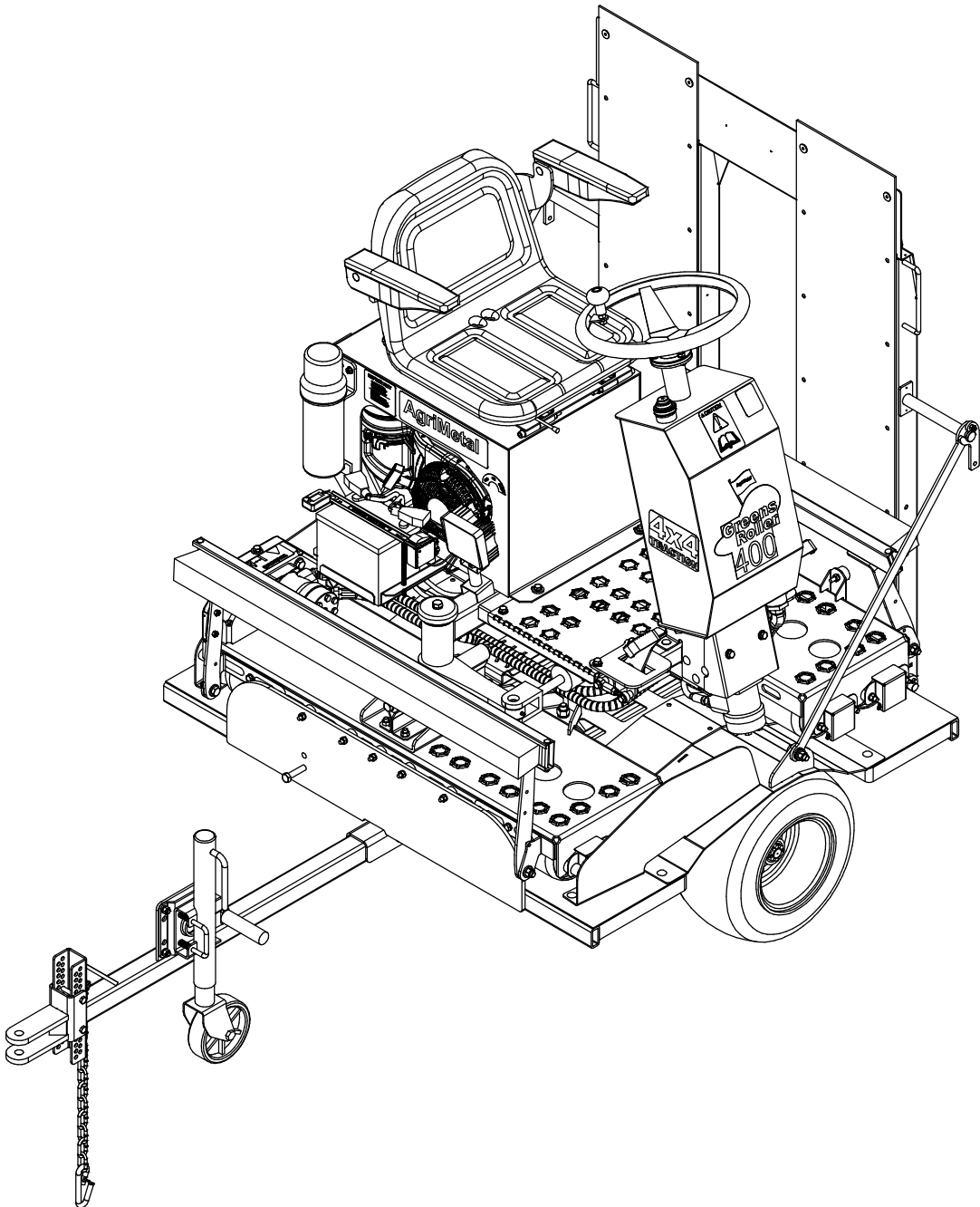

**GR400-F (14HP KOHLER)**

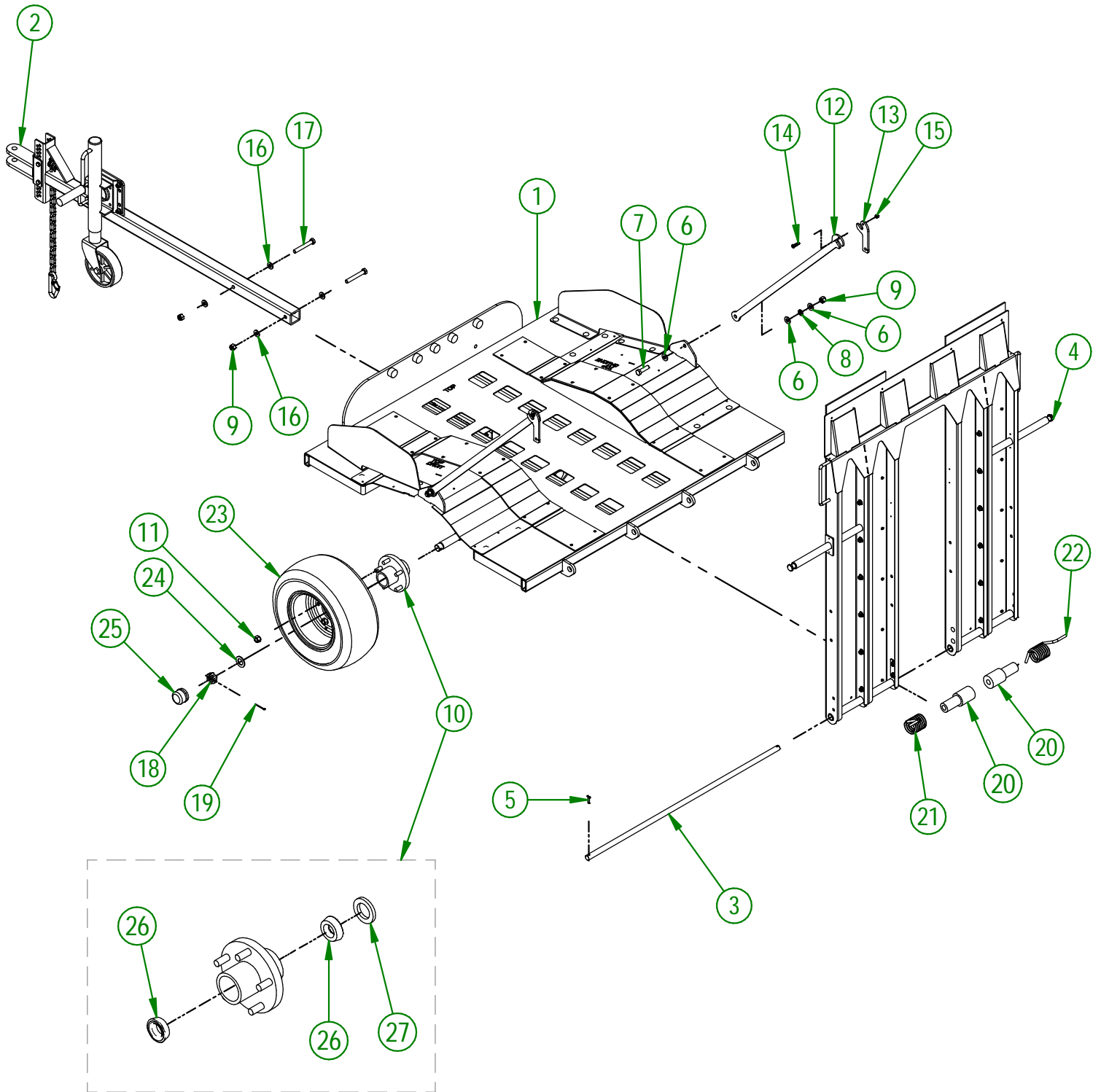

USE THESE PIECES ONLY IF YOUR SERIAL NUMBER IS AFFECTED:

#43193 AND UNDER

<b>AGRIMETAL</b>	
<b>TRAILER (2 WHEELS)</b>	
CREATION : 20/04/21	ASSEMBLY : <b>39-55-0521</b>
REVISION : 09/07/24	AUTHOR : G.HUBERDEAU

## 39-55-0521

#	PART #	Qty	TITLE
1	39-57-0521	1	TRAILER
2	39-55-0314	1	DRAWBAR GROUPING
3	39-13-0640	1	PIVOT RAMP
4	39-55-0812	1	RAMP
5	NC01-69-0159	2	COTTER PIN ZINC 3/16 X 1 1/2"
6	NC02-25-0011	6	WASHER SAE ZINC 17/32 ID
7	NC01-17-0250	2	HEX. BOLT GR2 ZINC 1/2-13 X 1 3/4"
8	NC02-32-0014	2	LOCK WASHER ZINC 1/2"
9	NC01-96-0014	5	NYLON-INSERT LOCKNUT ZINC 1/2-13
10	NC14-70-0643	2	HUB
11	NC02-12-0005	10	HEX. NUT ZINC 1/2-20
12	39-04-0441	2	RAMP LOCK
13	39-04-0360	2	DOOR LOCK
14	NC01-29-0006	2	HEX. BOLT GR5 NF ZINC 1/4-28 X 1 1/2"
15	NC01-97-0004	2	NYLON-INSERT LOCKNUT ZINC 1/4-28
16	01-01-0925	5	WASHER
17	NC01-17-0257	3	HEX. BOLT GR2 ZINC 1/2-13 X 3 1/2"
18	NC14-70-0310	2	SLOTTED NUT 1-14
19	NC14-70-0311	2	COTTER PIN ZINC 5/32" X 2"
20	39-42-0125	2	SPRING BUSHING
21	NC13-85-0060	1	TRAILER RAMP SPRING
22	NC13-85-0059	1	TRAILER RAMP SPRING
23	NC14-70-0644	2	Wheels GR400
24	NC14-70-0605	2	WASHER
25	NC14-70-0092	2	DUST GUARD

## NC14-70-0643

#	PART #	Qty	TITLE
26	NC14-70-0093	2	EXTERIOR BEARING
27	NC14-70-0324	1	SEAL 1.219" X 1.980"

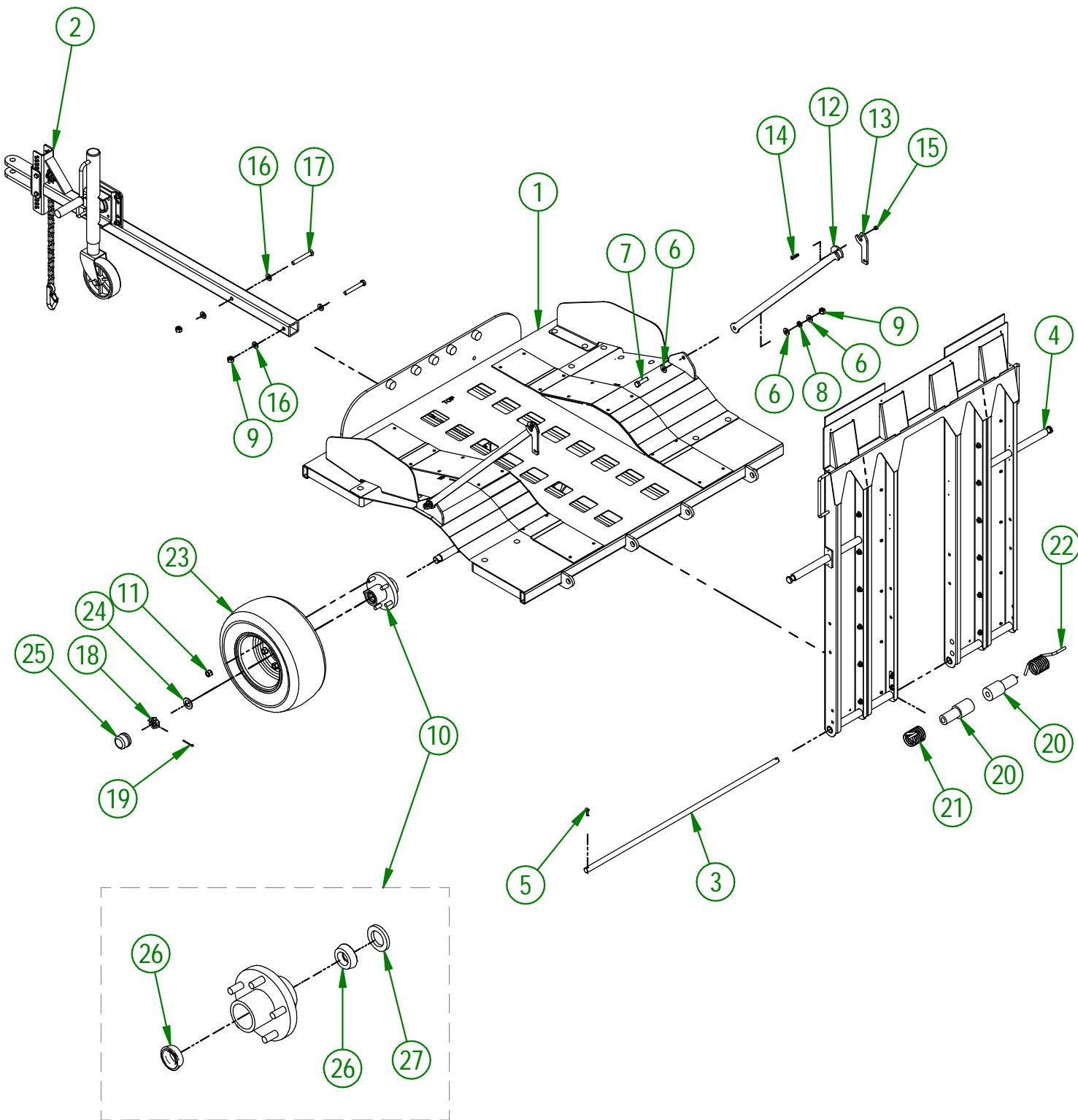

USE THESE PIECES ONLY IF YOUR SERIAL NUMBER IS AFFECTED:

#43193 AND ABOVE

<b>AGRIMETAL</b>	
<b>TRAILER (2 WHEELS)</b>	
CREATION : 17/10/22	ASSEMBLY : <b>39-55-0522</b>
REVISION : 09/07/24	AUTHOR : D. CHASSÉ

39-55-0522

#	PART #	Qty	TITLE
1	39-57-0523	1	TRAILER
2	39-55-0314	1	DRAWBAR GROUPING
3	39-13-0640	1	PIVOT RAMP
4	39-55-0812	1	RAMP
5	NC01-69-0159	2	COTTER PIN ZINC 3/16 X 1 1/2"
6	NC02-25-0011	6	WASHER SAE ZINC 17/32 ID
7	NC01-17-0250	2	HEX. BOLT GR2 ZINC 1/2-13 X 1 3/4"
8	NC02-32-0014	2	LOCK WASHER ZINC 1/2"
9*	NC01-96-0014	5	NYLON-INSERT LOCKNUT ZINC 1/2-13
10	NC14-70-0643	2	HUB
11	NC02-12-0005	10	HEX. NUT ZINC 1/2-20
12	39-04-0441	2	RAMP LOCK
13	39-04-0360	2	DOOR LOCK
14	NC01-29-0006	2	HEX. BOLT GR5 NF ZINC 1/4-28 X 1 1/2"
15	NC01-97-0004	2	NYLON-INSERT LOCKNUT ZINC 1/4-28
16	01-01-0925	5	WASHER
17	NC01-17-0257	3	HEX. BOLT GR2 ZINC 1/2-13 X 3 1/2"
18	NC14-70-0310	2	SLOTTED NUT 1-14
19	NC14-70-0311	2	COTTER PIN ZINC 5/32" X 2"
20	39-42-0125	2	SPRING BUSHING
21	NC13-85-0060	1	TRAILER RAMP SPRING
22	NC13-85-0059	1	TRAILER RAMP SPRING
23	NC14-70-0644	2	Wheels GR400
24	NC14-70-0605	2	WASHER
25	NC14-70-0092	2	DUST GUARD

NC14-70-0643

#	PART #	QTY	TITLE
26	NC14-70-0093	2	EXTERIOR BEARING
27	NC14-70-0324	1	SEAL 1.219" X 1.980"

#	PART #	Qty	TITLE
1	39-50-0802	1	TRAILER
2	39-42-0047	2	TRAILER RUBBER
3	NC01-78-0300	24	RIVETS AC. AV. SUPR. TI. AC. .187 X .515 CAP. RIVET .270
4	NC13-15-0034	5	RUBBER ABSORBER
5	NC02-32-0011	5	LOCK WASHER ZINC 5/16"
6	NC02-07-0017	5	HEX. NUT 5/16-18
7	NC01-04-0107	20	CARR. BOLT GR2 ZINC 3/8-16 X 3/4"
8	NC02-14-0019	20	FLANGE NUT HEX. NC 3/8-16 GR. B
9	39-50-0605	1	LEFT WHEEL FENDER
10	39-50-0600	1	RIGHT WHEEL FENDER
11	39-01-0136	1	POSITIONING GUIDE
12	39-01-0138	1	POSITIONING GUIDE

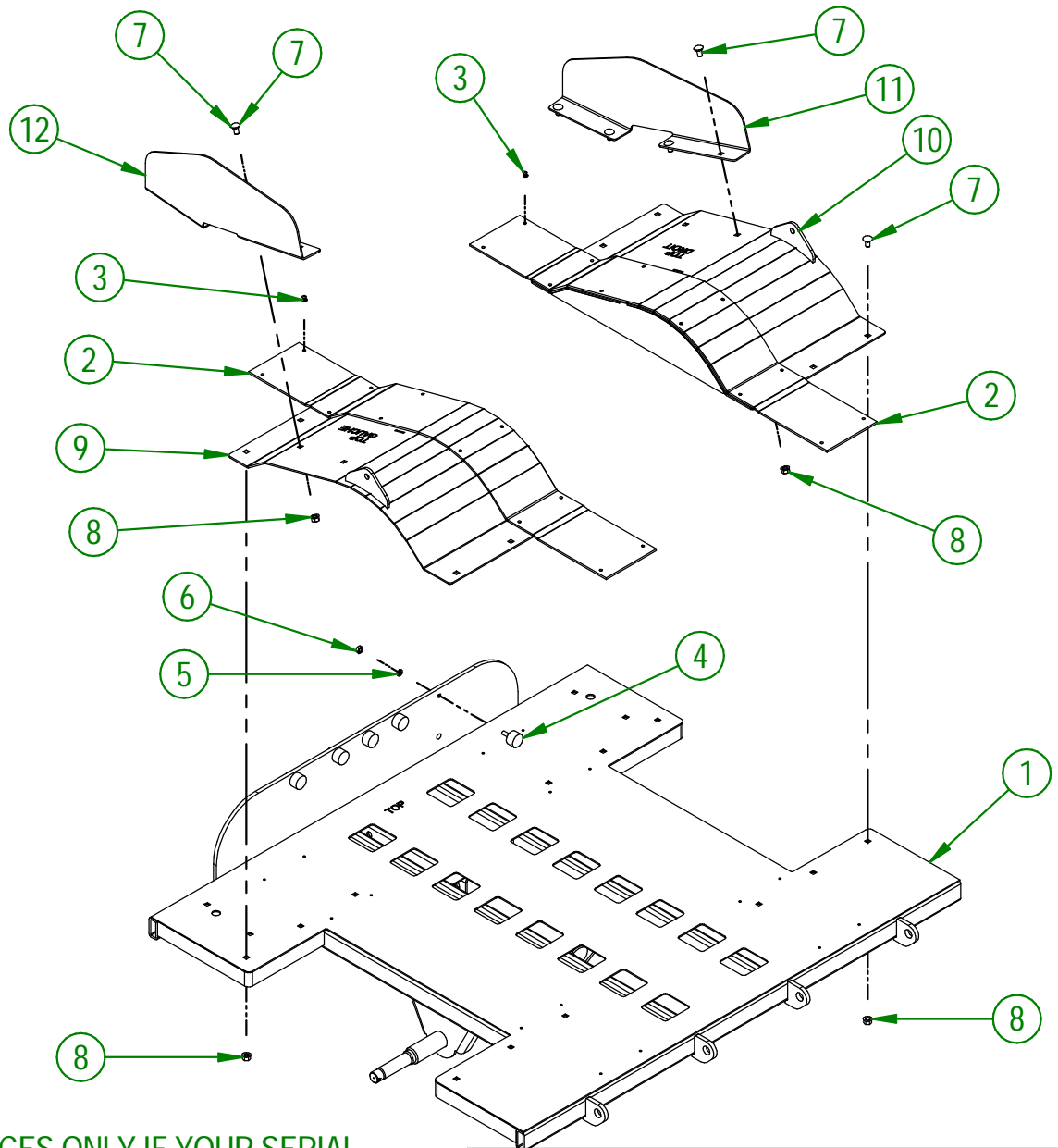

USE THESE PIECES ONLY IF YOUR SERIAL NUMBER IS AFFECTED:

#43193 AND BELOW

**AGRIMETAL TRAILER**

CREATION : 07/01/21  
REVISION : 16/01/23

ASSEMBLY : **39-57-0520**  
AUTHOR : J. Houle

#	PART #	Qty	TITLE
1	39-50-0802	1	TRAILER
2	NC01-78-0300	24	RIVETS AC. AV. SUPR. TI. AC. .187 X .515 CAP. RIVET .270
3	39-42-0049	2	TRAILER RUBBER
4	NC13-15-0034	5	RUBBER ABSORBER
5	NC02-32-0011	5	LOCK WASHER ZINC 5/16"
6	NC02-07-0017	5	HEX. NUT 5/16-18
7	NC01-04-0107	20	CARR. BOLT GR2 ZINC 3/8-16 X 3/4"
8	NC02-14-0019	20	FLANGE NUT HEX. NC 3/8-16 GR. B
9	39-50-0607	1	LEFT WHEEL FENDER
10	39-50-0602	1	RIGHT WHEEL FENDER
11	39-01-0350	1	POSITIONING GUIDE
12	39-01-0345	1	POSITIONING GUIDE

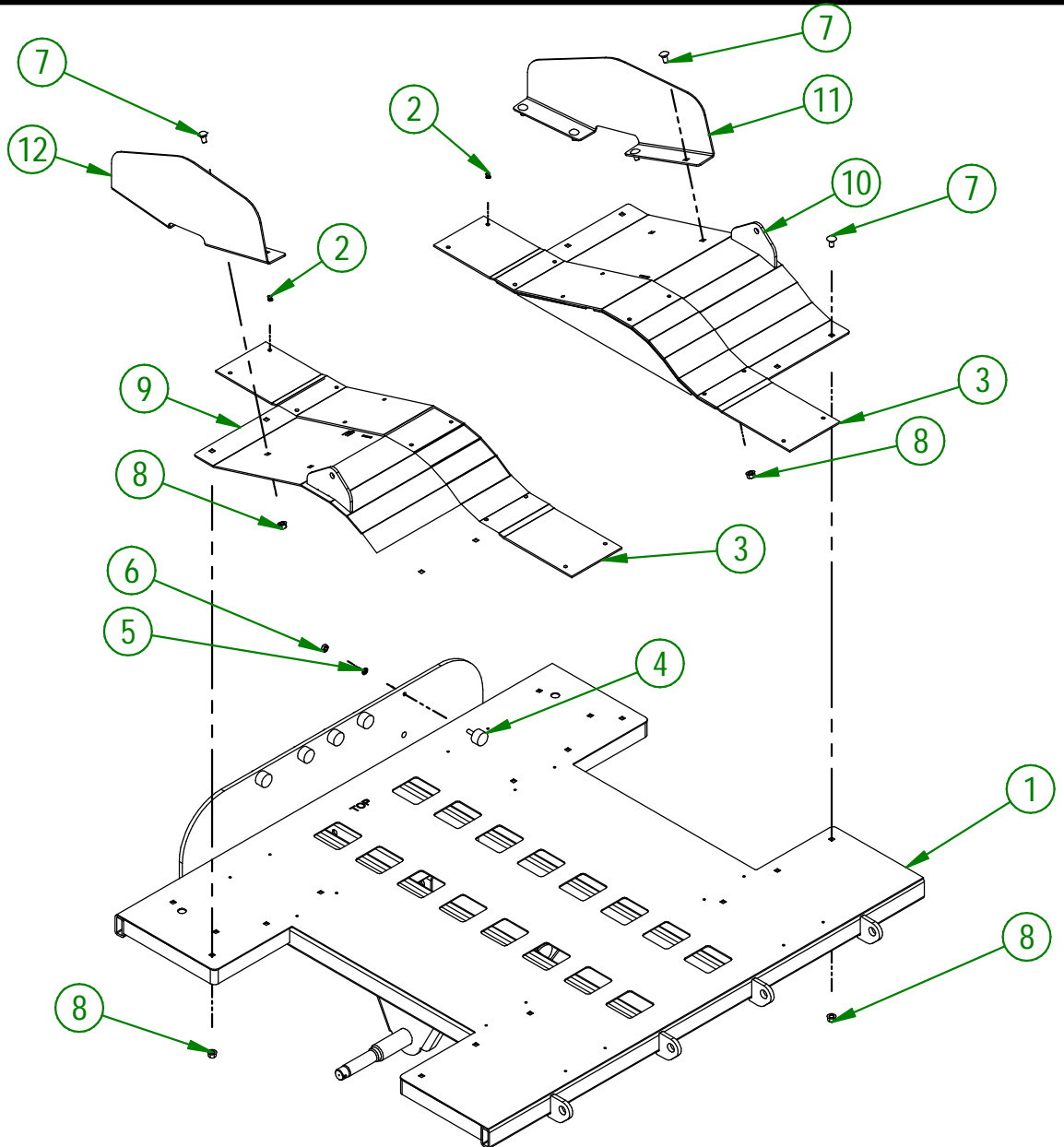

USE THESE PIECES ONLY IF YOUR SERIAL NUMBER IS AFFECTED:

#43193 AND ABOVE

**AGRIMETAL TRAILER**

CREATION : 17/10/22  
REVISION : 16/01/23

ASSEMBLY : **39-57-0523**  
AUTHOR : D. CHASSÉ

#	PART #	Qty	TITLE
1	39-50-0327	1	DRAWBAR
2	33-50-0055	1	WELD ASSEMBLY HAND
3	NC01-17-0123	2	HEX. BOLT GR2 ZINC 3/8-16
4	NC02-32-0012	6	LOCK WASHER ZINC 3/8"
5	NC02-07-0018	6	HEX. NUT ZINC 3/8-16
6	NC01-17-0116	1	HEX. BOLT GR2 ZINC 3/8-16 X 1 1/2"
7	21-01-0950	4	FLAT WASHER IOGA 1.005" DIA X 25/64"
8	55-41-0000	1	SAFETY CHAIN
9	NC01-96-0011	1	NYLON NUT 3/8-16
10	39-55-0330	1	ADJUSTABLE WHEEL CRUTCH
11	NC01-04-0109	4	CARR. BOLT GR2 ZINC 3/8-16 X 1"

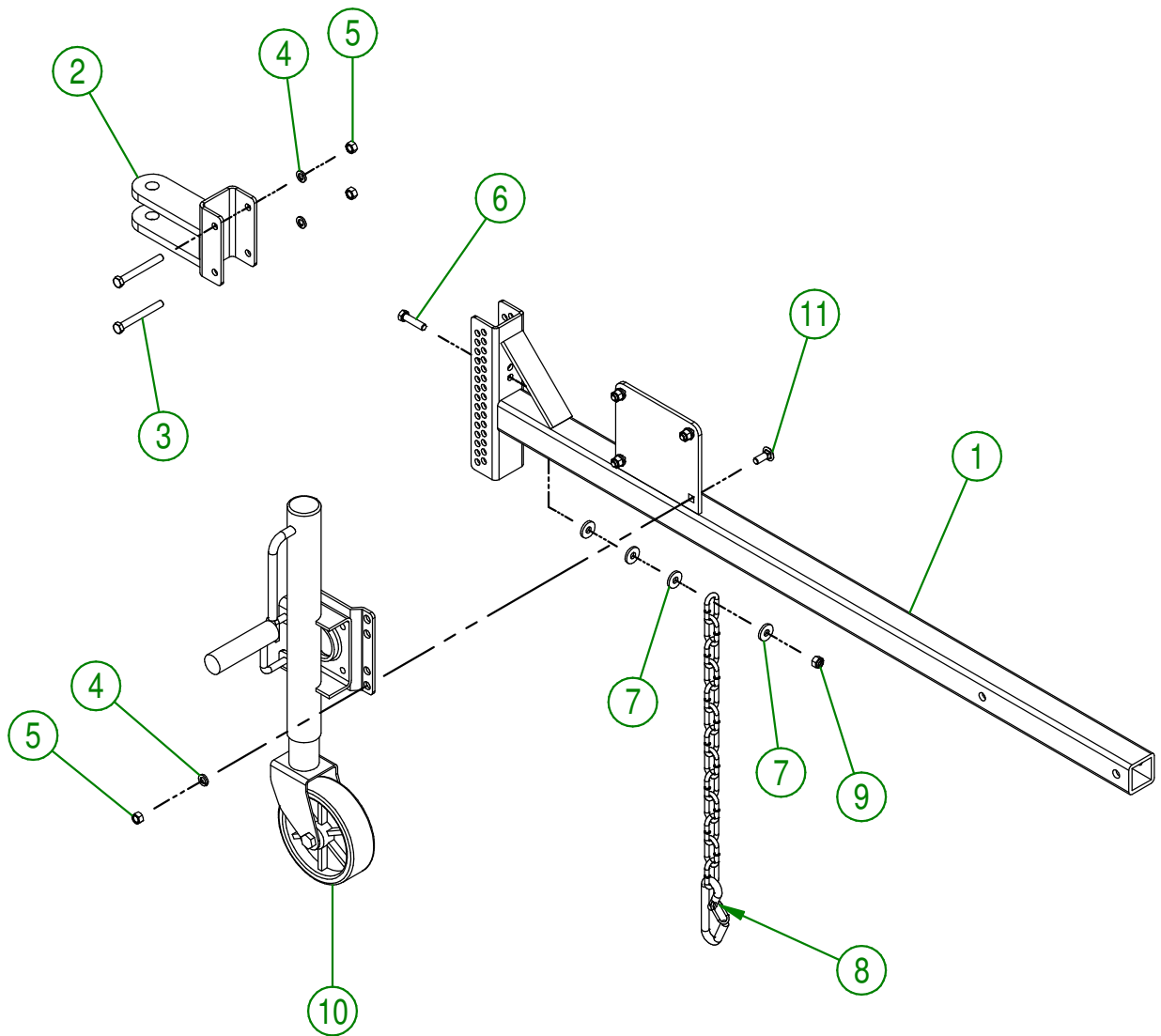

<b>AGRIMETAL</b>	
<b>DRAWBAR GROUPING</b>	
CREATION : 07/01/21	ASSEMBLY : <b>39-55-0314</b>
REVISION : 06/12/21	AUTHOR : J. Houle



39-55-0812

#	PART #	Qty	TITLE
1	39-50-0812	1	TRAILER RAMP
2	39-42-0031	2	RAMP RUBBER
3	NC01-78-0300	24	RIVETS AC. AV. SUPR. TI. AC. .187 X .515 CAP. RIVET .270
4	NC01-78-0405	4	STEEL BLIND POP RIVET STEEL MANDREL 0.187 X 0.690
5	39-01-0170	2	TRAILER RAMP REINFORCEMENT
6	NC01-04-0055	4	CARR. BOLT GR2 ZINC 5/16-18 X 5/8"
7	NC02-14-0006	4	HEX. NUT SPECIAL FLANGET NC 5/16-18 B GRADE
8	16-01-2720	4	WASHER 13/16" DIA. X 13/64"

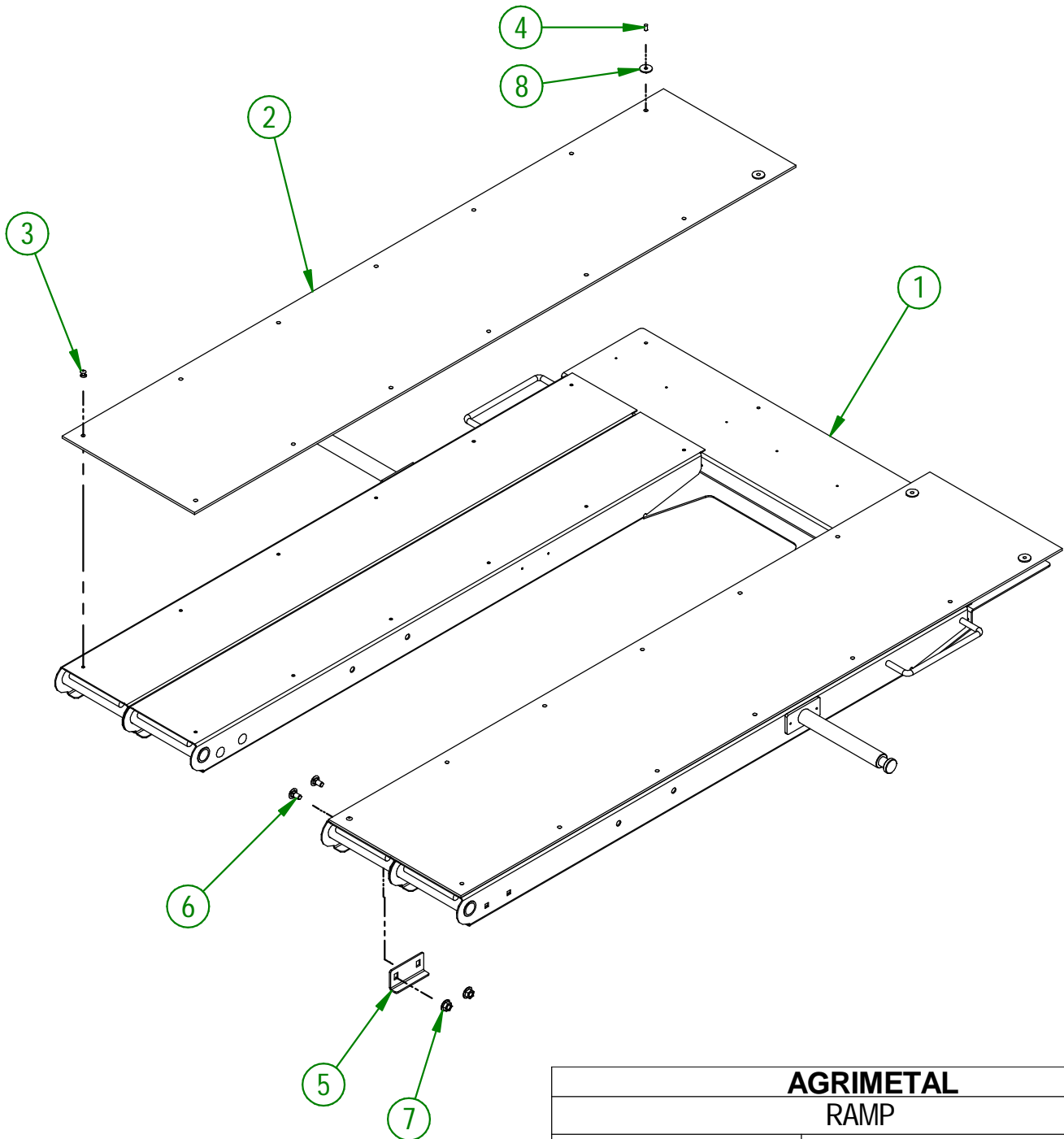

**AGRIMETAL**

**RAMP**

CREATION : 07/01/21  
 REVISION : 24/08/23

ASSEMBLY : **39-55-0812**

AUTHOR : J. Houle

#	PART #	Qty	TITLE
1	39-50-0502	1	FRAME
2	39-57-0125	1	FOOTBOARD "STICKER INCLUDED"
3	NC13-15-0034	2	RUBBER ABSORBER
4	39-50-0020	1	OIL FILTER HOLDER
5	01-01-2485	6	FLAT WASHER 14 GA X 13/16"OD X 25/64" ID
6	NC02-32-0012	8	LOCK WASHER ZINC 3/8"
7	NC01-17-0112	2	HEX. BOLT GR2 ZINC 3/8-16 X 3/4"
8	NC01-17-0114	4	HEX. BOLT GR2 ZINC 3/8-16 X 1"
9	NC02-32-0011	4	LOCK WASHER ZINC 5/16"
10	NC02-07-0017	2	HEX. NUT 5/16-18
11	NC01-17-0060	2	HEX. BOLT GR2 ZINC 5/16-18 X 1"
12	NC01-04-0109	2	CARR. BOLT GR2 ZINC 3/8-16 X 1"
13	NC02-07-0018	2	HEX. NUT ZINC 3/8-16
14	39-04-0186	1	STOPPER PLATE FOR PEDAL (RIGHT)
15	39-04-0188	1	STOPPER PLATE FOR PEDAL (LEFT)
16	NC13-25-0378	2	WHITE METAL CONNECTOR
17	NC13-15-0014	2	RUBBER WIRE WASHER

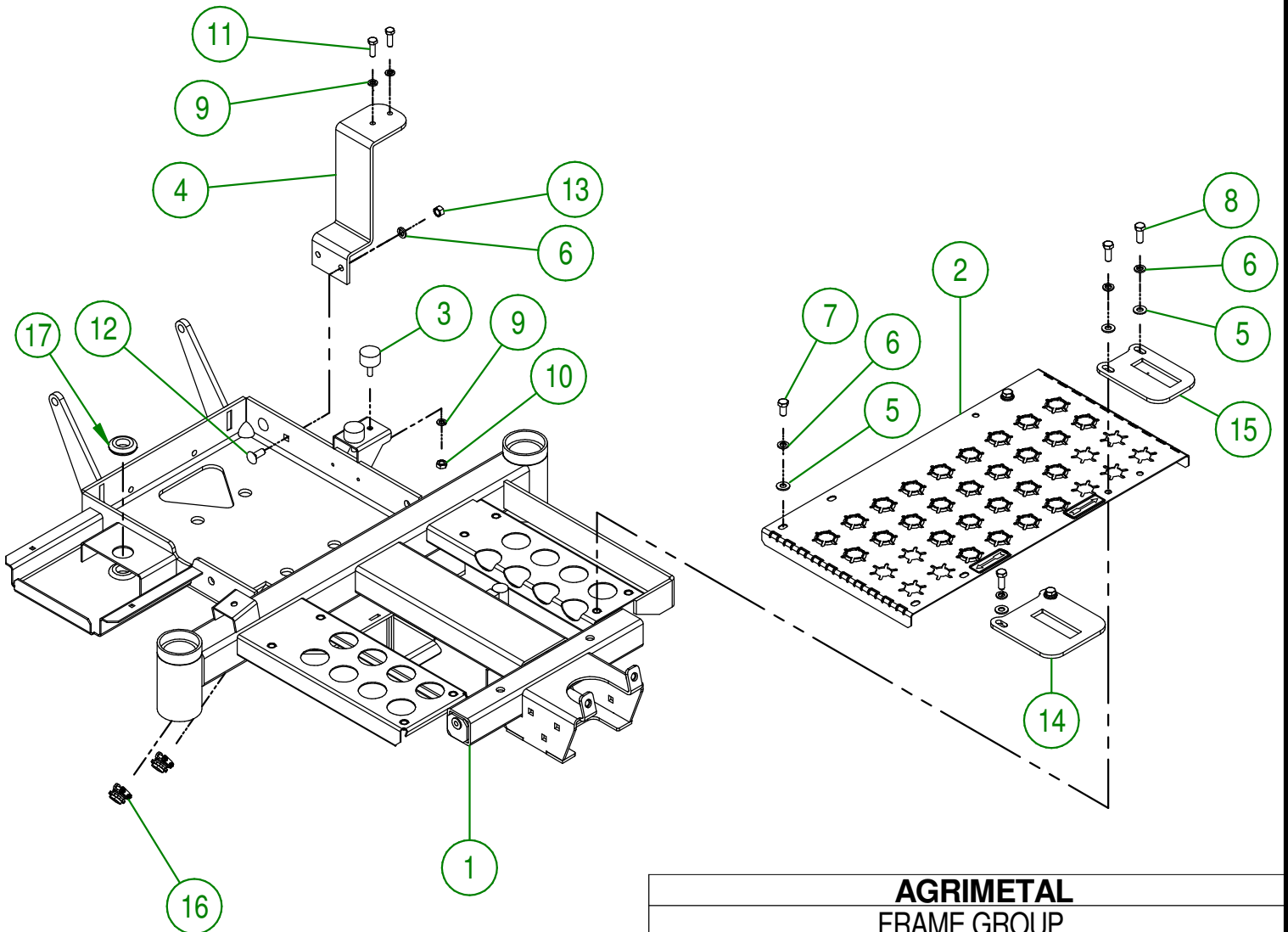

**AGRIMETAL**  
**FRAME GROUP**

CREATION : 30/12/20  
REVISION : 30/12/20

ASSEMBLY : **39-57-0502**  
AUTHOR : J. Houle

39-57-0603

#	PART #	Qty	TITLE
1	39-55-0620	1	ROLLER & HOUSING ASSY. (RIGHT)
2	39-42-0703	1	PIVOTING BLOCK
3	39-09-1207	1	BUSHING
4	NC02-32-0017	1	LOCK WASHER ZINC 3/4"
5	NC02-11-0023	1	NUT 3/4-16
6	NC01-37-0484	1	HEX BOLT. GR8 NF ZINC 3/4-16 X 7 1/2"

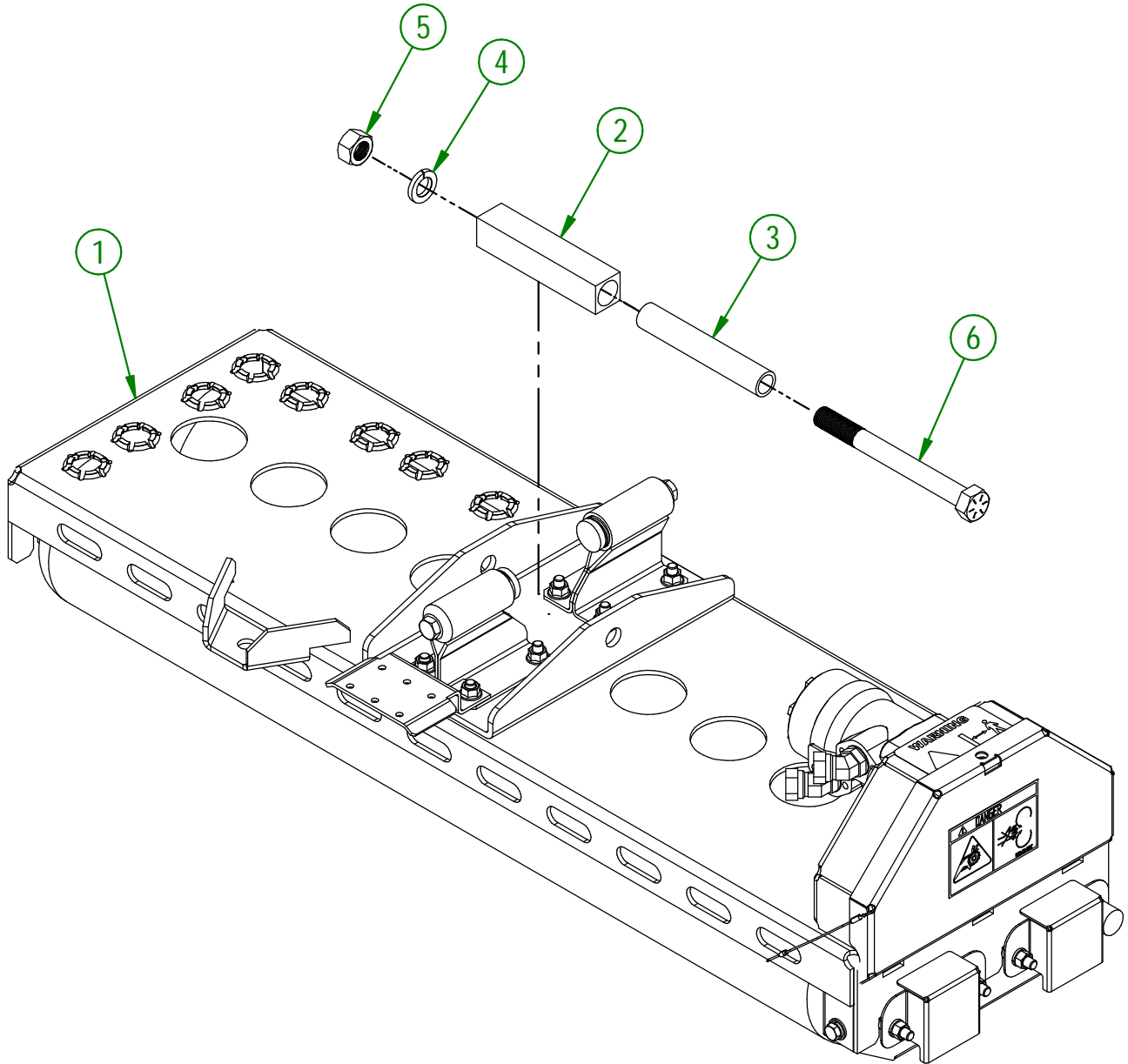

<b>AGRIMETAL</b>	
<b>RIGHT ROLLER GROUP</b>	
CREATION : 10/02/22	ASSEMBLY : <b>39-57-0603</b>
REVISION : 10/02/22	AUTHOR : J. Houle

**NEW CHAIN TENSIONER ARM**

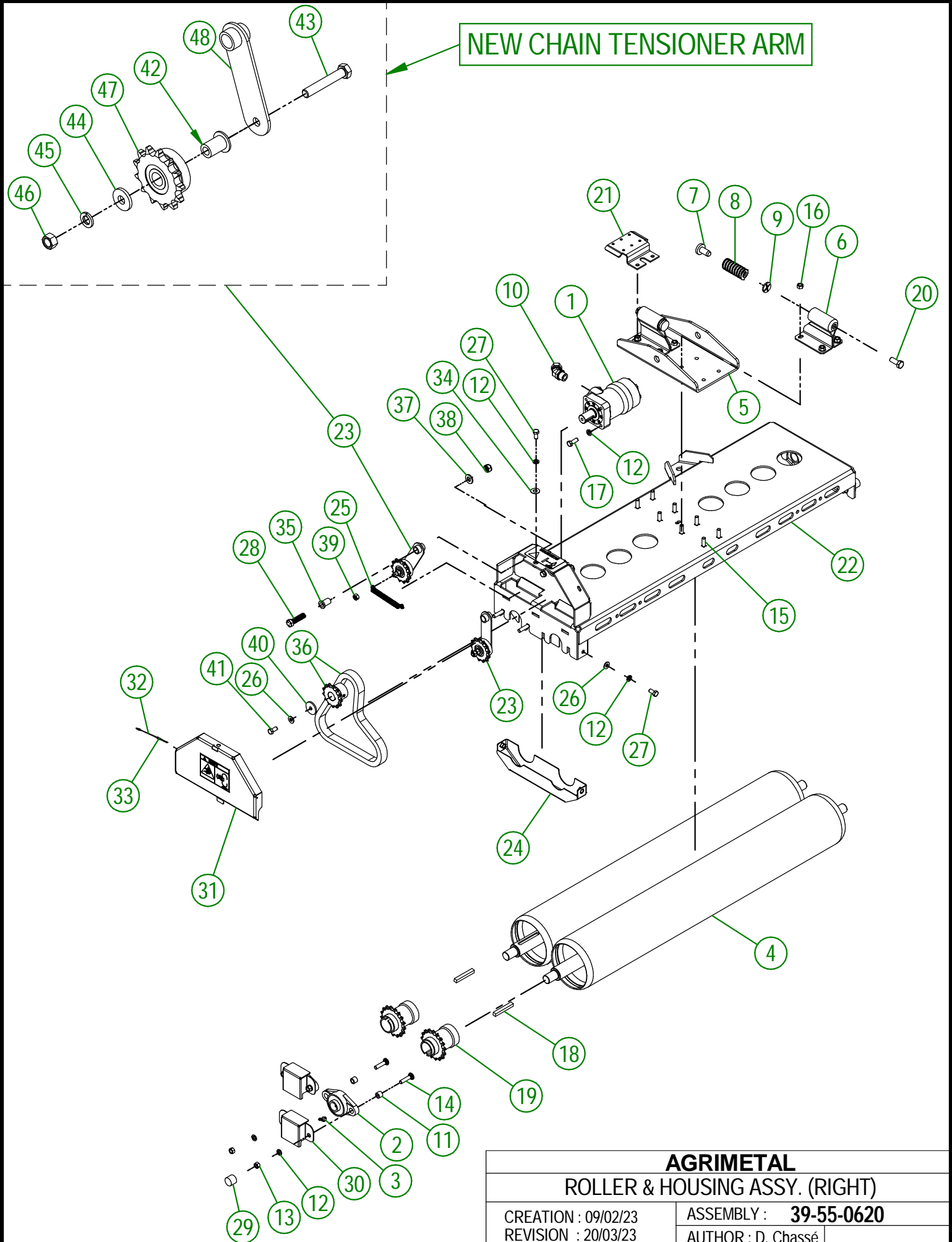

<b>AGRIMETAL</b>	
<b>ROLLER &amp; HOUSING ASSY. (RIGHT)</b>	
CREATION : 09/02/23	ASSEMBLY : <b>39-55-0620</b>
REVISION : 20/03/23	AUTHOR : D. Chassé

# IMPORTANT

IF YOUR CHAIN TENSIONER ARMS HAVE BENDS LIKE THE PICTURE, YOU HAVE TO ORDER THE REPLACEMENT KIT 39-57-0225

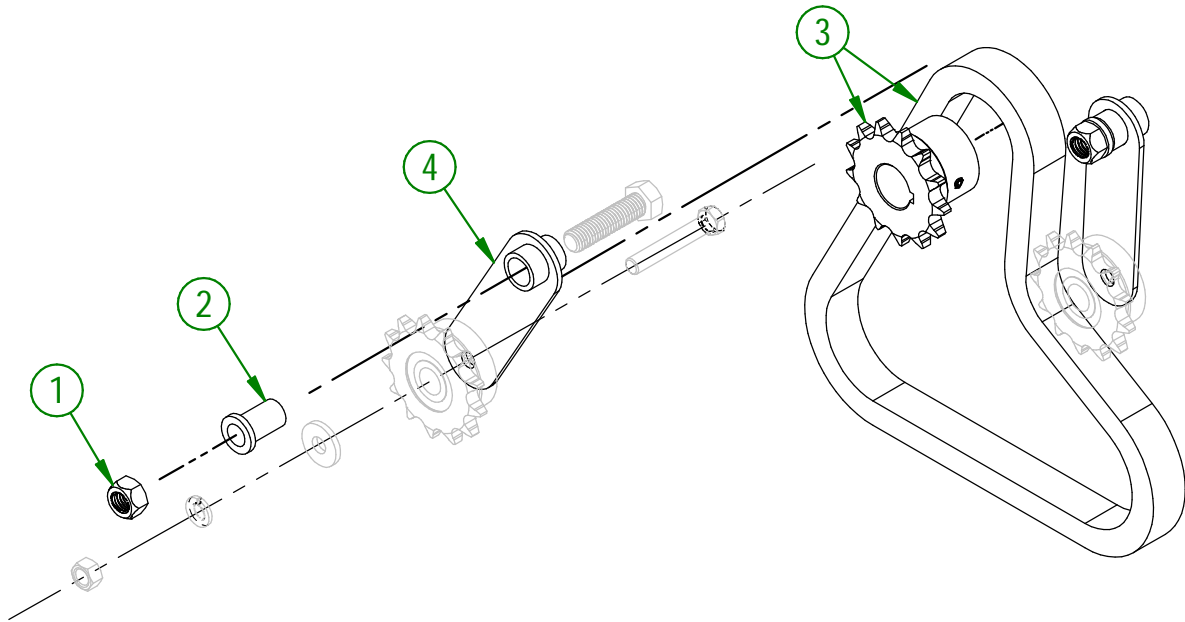
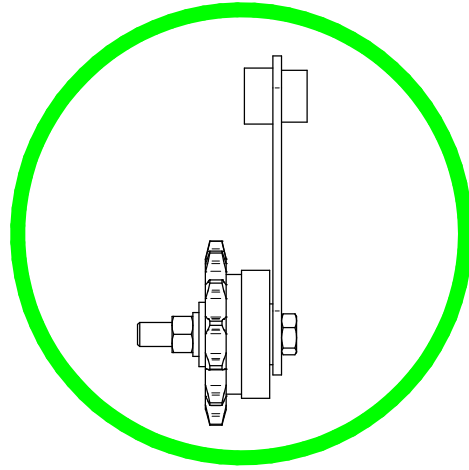
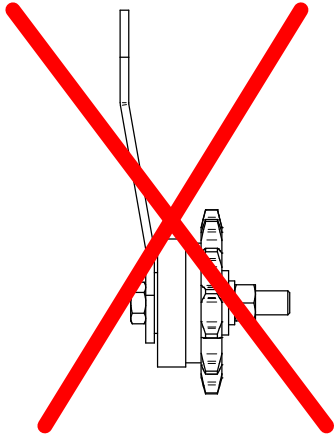

39-57-0225

#	PART #	Qty	TITLE
1	NC01-93-0014	2	LOCK NUT ZINC 1/2-13
2	39-13-0115	2	BUSHING
3	39-57-0225	1	CHAIN AND SPOCKET KIT
4	39-50-0155	2	CHAIN TENSIONNER PIVOT

## 39-55-0620

#	PART #	Qty	TITLE
1	NC14-45-0041	1	100cc HYDRAULIC MOTOR
2	NC14-75-0019	4	FLANGE PILLOW BLOCK BEARING UCFL205-16 Ø 1"
3	NC01-69-0802	4	GREASE FITTING 6mm X 45mm
4	39-50-0596	2	ROLLER
5	39-04-0227	1	ROLLER SUPPORT
6	39-50-0045	2	SPRING GUIDE
7	39-42-0100	2	SPRING TIP
8	NC13-86-0159	2	RED SPRING 1 1/4"OD X 5/8"ID X 2" LG
9	39-01-1000	2	SPRING GUIDE WASHER
10	NC13-45-0046	2	45°-7/8-14 MALE O RING X 1/2 FEM.TOUR.NPT PT
11	01-09-0000	8	BEARING RACE (UCFL205-16)
12	NC02-32-0012	15	LOCK WASHER ZINC 3/8"
13	NC02-07-0018	8	HEX. NUT ZINC 3/8-16
14	NC01-04-0111	8	CARR. BOLT GR2 ZINC 3/8-16 X 1 1/2"
15	NC01-04-0110	8	CARR. BOLT GR2 ZINC 3/8-16 X 1 1/4"
16	NC02-14-0019	8	FLANGE NUT HEX. NC 3/8-16 GR. B
17	NC01-17-0114	4	HEX. BOLT GR2 ZINC 3/8-16 X 1"
18	48-41-0905	2	SQUARE KEY 3/8" X 2 3/4" LG
19	NC14-55-0333	2	ROLLER SPROCKET
20	NC01-17-0248	2	HEX. BOLT GR2 ZINC 1/2-13 X 1 1/4"
21	39-01-1051	1	HYDRAULIC HOSE SUPPORT
22	39-57-0181	1	ROLLER HOUSING STICKERS INCLUDED (RIGHT) GROUP.
23	39-55-0161	2	CHAIN TENSIONER ARM
24	39-50-0130	1	ROLLER CHAIN GUARD
25	NC13-85-0058	1	CHAIN TENSIONER SPRING
26	01-01-2485	3	FLAT WASHER 14 GA X 13/16"OD X 25/64" ID
27	NC01-17-0112	3	HEX. BOLT GR2 ZINC 3/8-16 X 3/4"
28	NC01-25-0251	2	HEX.BOLT GR5 NC ZINC 1/2-13 X 2"
29	39-42-0110	2	ROLLER NUT CAP
30	39-01-0130	4	BEARING GUARD
31	39-57-0061	1	CHAIN GUARD
32	39-41-0005	1	ROLLER CHAIN GUARD CABLE
33	NC01-64-0005	2	OVAL SLEEVE (ALUMINUM)
34	NC02-22-0010	1	WASHER 13/32" ID
35	39-13-0115	2	BUSHING
36	39-57-0255	1	CHAIN AND SPOCKET KIT
37	NC02-25-0011	2	WASHER SAE ZINC 17/32 ID
38	NC01-93-0014	2	LOCK NUT ZINC 1/2-13
39	NC01-93-0011	2	LOCK NUT 3/8-16
40	39-21-0075	1	WASHER FOR HYDRAULIC MOTOR
41	NC01-24-0007	1	HEX. BOLT GR5 BLACK 3/8-16 X 3/4"

39-55-0161

#	PART #	Qty	TITLE
42	39-21-0070	1	CHAIN TENSIONER SHAFT
43	NC01-17-0119	1	HEX. BOLT GR2 ZINC 3/8-16 X 2 1/4"
44	21-01-0950	1	FLAT WASHER 10GA 1.005" DIA X 25/64"
45	NC02-32-0012	1	LOCK WASHER ZINC 3/8"
46	NC02-07-0018	1	HEX. NUT ZINC 3/8-16
47	39-55-0165	1	CHAIN TENSIONER SPROCKET ASSEMBLY
48	39-50-0155	1	CHAIN TENSIONNER PIVOT

39-57-0608

#	PART #	Qty	TITLE
1	39-55-0625	1	ROLLER HOUSING ASSY. (LEFT)
2	39-42-0703	1	PIVOTING BLOCK
3	39-09-1207	1	BUSHING
4	39-50-0573	1	LEFT PIVOT TRAILER
5	39-21-0000	1	STEERING PLATE SHAFT COVER
6	NC02-32-0014	1	LOCK WASHER ZINC 1/2"
7	NC01-17-0249	1	HEX. BOLT GR2 ZINC 1/2-13 X 1 1/2"
8	NC01-37-0484	1	HEX BOLT. GR8 NF ZINC 3/4-16 X 7 1/2"
9	NC02-32-0017	1	LOCK WASHER ZINC 3/4"
10	NC02-11-0023	1	NUT 3/4-16
11	NC14-75-0091	2	6206 ZZ BEARING

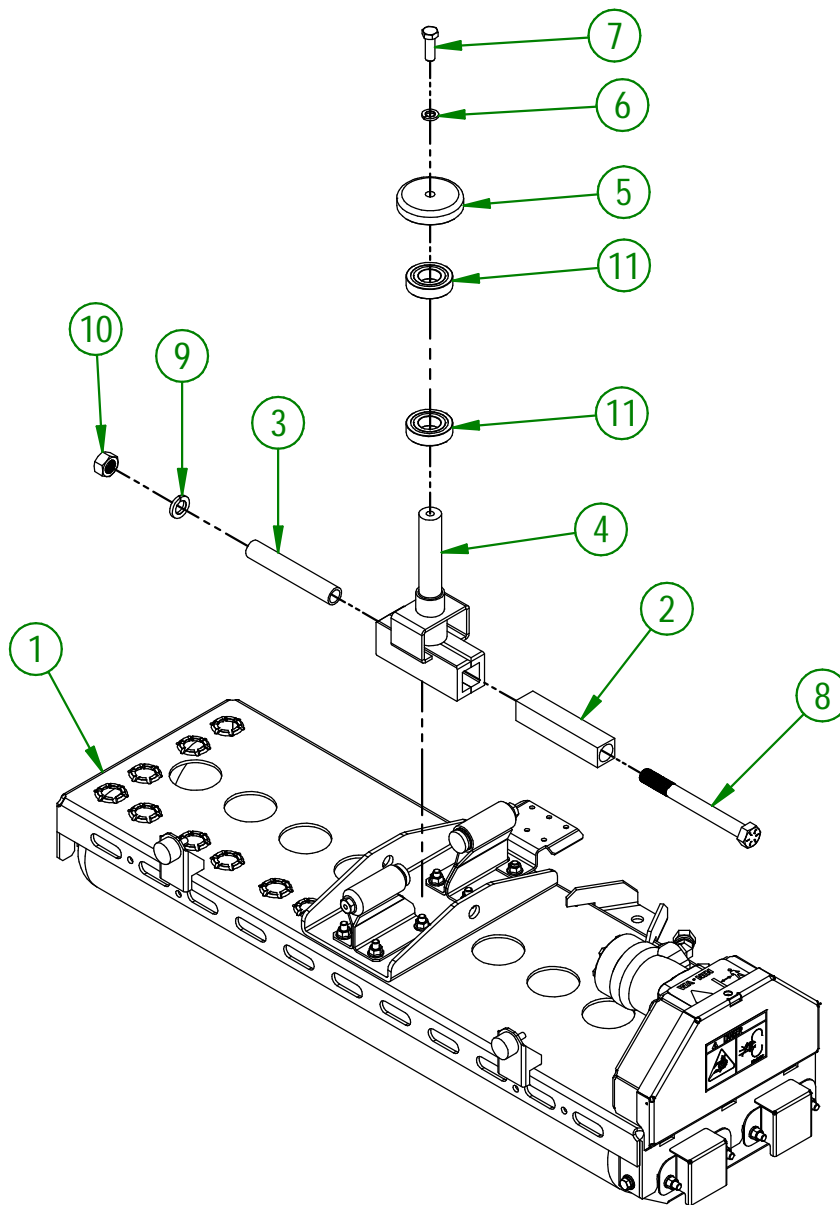

<b>AGRIMETAL</b>	
<b>LEFT ROLLER GROUP</b>	
CREATION : 10/02/22	ASSEMBLY : <b>39-57-0608</b>
REVISION : 10/02/22	AUTHOR : J. Houle



**NEW CHAIN TENSIONER ARM**

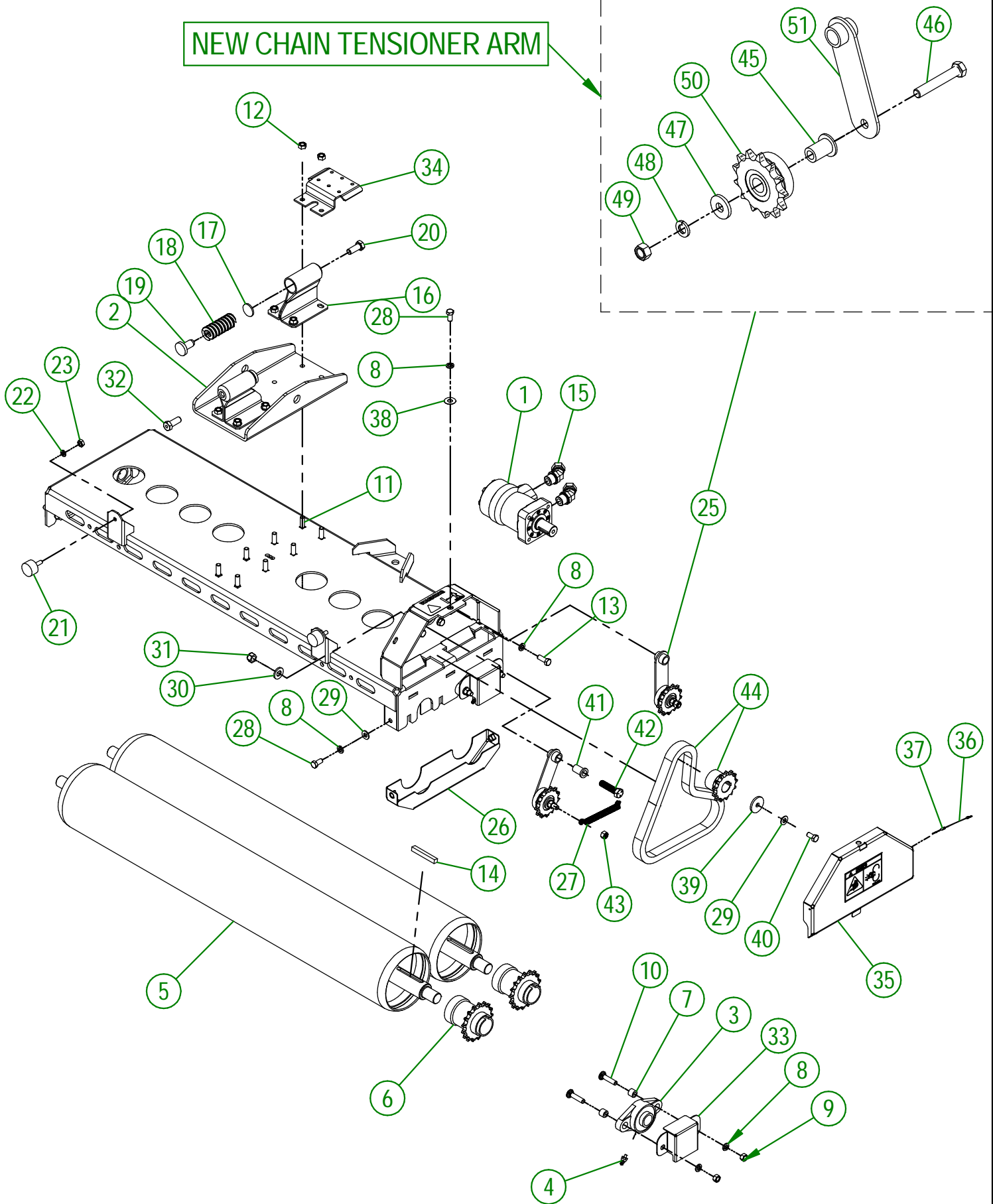

<b>AGRIMETAL</b>	
<b>ROLLER HOUSING ASSY. (LEFT)</b>	
CREATION : 10/02/22	ASSEMBLY : <b>39-55-0625</b>
REVISION : 20/03/23	AUTHOR : D. Chassé

# IMPORTANT

IF YOUR CHAIN TENSIONER ARMS HAVE BENDS LIKE THE PICTURE, YOU HAVE TO ORDER THE REPLACEMENT KIT 39-57-0225

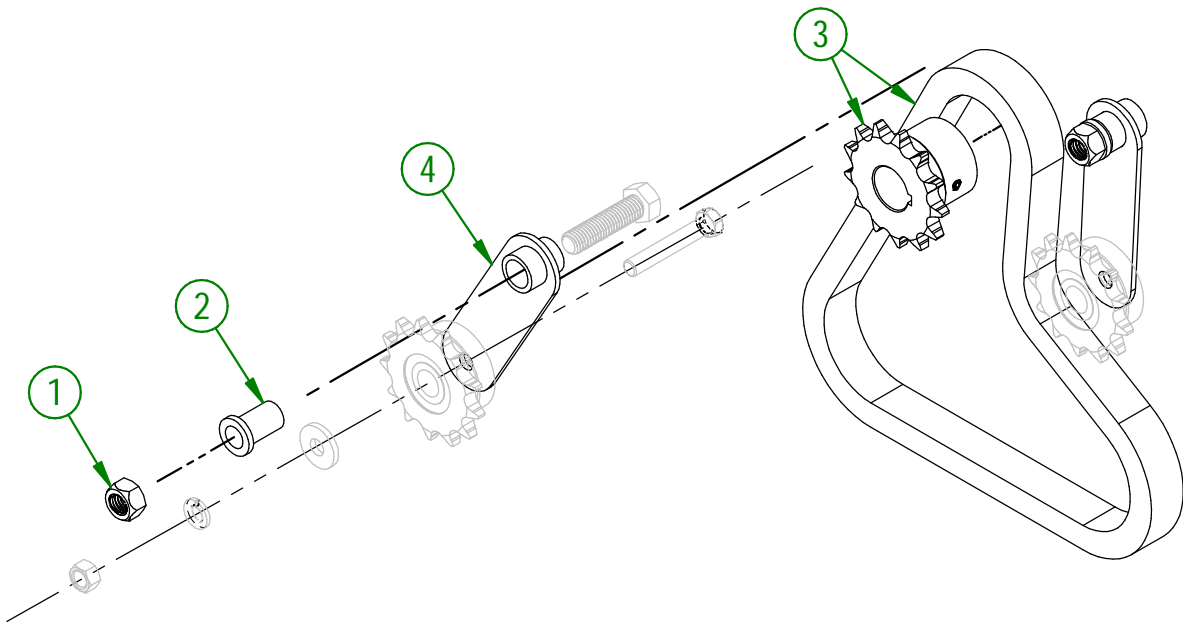
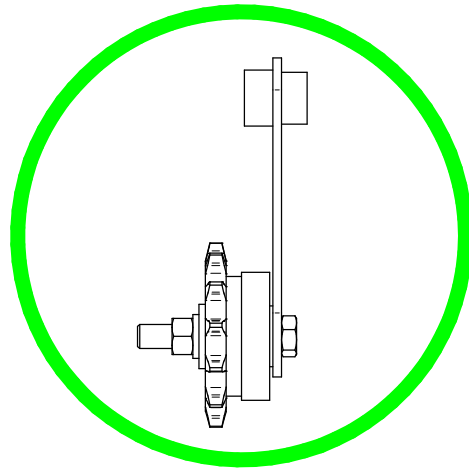
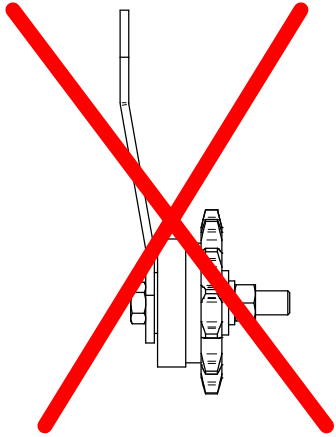

39-57-0225

#	PART #	Qty	TITLE
1	NC01-93-0014	2	LOCK NUT ZINC 1/2-13
2	39-13-0115	2	BUSHING
3	39-57-0255	1	CHAIN AND SPOCKET KIT
4	39-50-0155	2	CHAIN TENSIONNER PIVOT

39-55-0625

#	PART #	Qty	TITLE
1	NC14-45-0041	1	100cc HYDRAULIC MOTOR
2	39-04-0227	1	ROLLER SUPPORT
3	NC14-75-0019	4	FLANGE PILLOW BLOCK BEARING UCFL205-16 Ø 1"
4	NC01-69-0802	4	GREASE FITTING 6mm X 45mm
5	39-50-0596	2	ROLLER
6	NC14-55-0333	2	ROLLER SPROCKET
7	01-09-0000	8	BEARING RACE (UCFL205-16)
8	NC02-32-0012	15	LOCK WASHER ZINC 3/8"
9	NC02-07-0018	8	HEX. NUT ZINC 3/8-16
10	NC01-04-0111	8	CARR. BOLT GR2 ZINC 3/8-16 X 1 1/2"
11	NC01-04-0110	8	CARR. BOLT GR2 ZINC 3/8-16 X 1 1/4"
12	NC02-14-0019	8	FLANGE NUT HEX. NC 3/8-16 GR. B
13	NC01-17-0114	4	HEX. BOLT GR2 ZINC 3/8-16 X 1"
14	48-41-0905	2	SQUARE KEY 3/8" X 2 3/4" LG
15	NC13-45-0046	2	45°-7/8-14 MALE O RING X 1/2 FEM.TOUR.NPT PT
16	39-50-0045	2	SPRING GUIDE
17	39-01-1000	2	SPRING GUIDE WASHER
18	NC13-86-0159	2	RED SPRING 1 1/4"OD X 5/8"ID X 2" LG
19	39-42-0100	2	SPRING TIP
20	NC01-17-0248	1	HEX. BOLT GR2 ZINC 1/2-13 X 1 1/4"
21	NC13-15-0034	2	RUBBER ABSORBER
22	NC02-32-0011	2	LOCK WASHER ZINC 5/16"
23	NC02-07-0017	2	HEX. NUT 5/16-18
24	39-57-0171	1	ROLLER HOUSING (LEFT)
25	39-55-0161	2	CHAIN TENSIONER ARM
26	39-50-0130	1	ROLLER CHAIN GUARD
27	NC13-85-0058	1	CHAIN TENSIONER SPRING
28	NC01-17-0112	3	HEX. BOLT GR2 ZINC 3/8-16 X 3/4"
29	01-01-2485	3	FLAT WASHER 14 GA X 13/16"OD X 25/64" ID
30	NC02-25-0011	2	WASHER SAE ZINC 17/32 ID
31	NC01-96-0014	2	NYLON-INSERT LOCKNUT ZINC 1/2-13
32	39-30-9960	1	LEFT LIGHT HOLDER
33	39-01-0130	4	BEARING GUARD
34	39-01-1051	1	HYDRAULIC HOSE SUPPORT
35	39-57-0061	1	CHAIN GUARD
36	39-41-0005	1	ROLLER CHAIN GUARD CABLE
37	NC01-64-0005	2	OVAL SLEEVE (ALUMINUM)
38	NC02-22-0010	1	WASHER 13/32" ID
39	39-21-0075	1	WASHER FOR HYDRAULIC MOTOR
40	NC01-24-0007	1	HEX. BOLT GR5 BLACK 3/8-16 X 3/4"
41	39-13-0115	2	BUSHING
42	NC01-25-0251	2	HEX.BOLT GR5 NC ZINC 1/2-13 X 2"
43	NC01-93-0011	2	LOCK NUT 3/8-16
44	39-57-0255	1	CHAIN AND SPOCKET KIT

39-55-0161

#	PART #	Qty	TITLE
45	39-21-0070	1	CHAIN TENSIONER SHAFT
46	NC01-17-0119	1	HEX. BOLT GR2 ZINC 3/8-16 X 2 1/4"
47	21-01-0950	1	FLAT WASHER 10GA 1.005" DIA X 25/64"
48	NC02-32-0012	1	LOCK WASHER ZINC 3/8"
49	NC02-07-0018	1	HEX. NUT ZINC 3/8-16
50	39-55-0165	1	CHAIN TENSIONER SPROCKET ASSEMBLY
51	39-50-0155	1	CHAIN TENSIONNER PIVOT

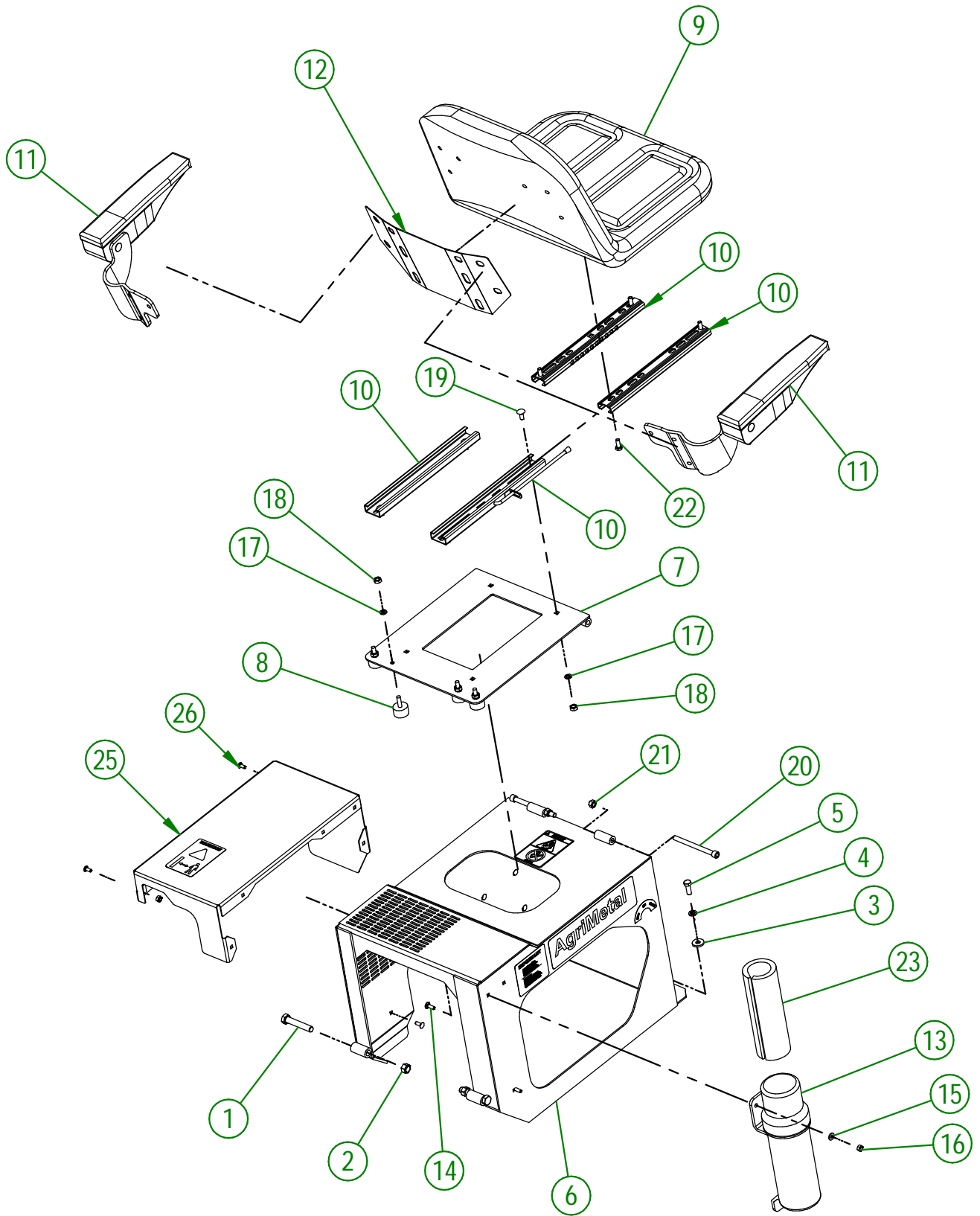

USE THESE PIECES ONLY IF YOUR SERIAL NUMBER IS AFFECTED:

BETWEEN #39530 AND #42832

<b>AGRIMETAL</b>	
<b>ENGINE COVER GROUP</b>	
CREATION : 08/01/21	ASSEMBLY : <b>39-57-0542</b>
REVISION : 02/12/22	AUTHOR : J. Houle

## 39-57-0542

#	PART #	Qty	TITLE
1	NC01-17-0254	2	HEX. BOLT GR2 ZINC 1/2-13 X 2 1/2"
2	NC01-96-0014	2	NYLON-INSERT LOCKNUT ZINC 1/2-13
3	21-01-0950	2	FLAT WASHER IOGA 1.005" DIA X 25/64"
4	NC02-32-0012	2	LOCK WASHER ZINC 3/8"
5	NC01-17-0114	2	HEX. BOLT GR2 ZINC 3/8-16 X 1"
6	39-57-0010	1	ENGINE COVER
7	39-50-0115	1	SEAT FOLDER HOLDER
8	NC13-15-0034	4	RUBBER ABSORBER
9	NC13-80-0200	1	SEAT
10	NC13-80-0201	1	SET OF SEAT RAIL
11	NC13-80-0295	1	ARMRESTS
12	39-01-0400	1	BACK REST SEAT REINFORCEMENT
13	NC13-30-0237	1	PLASTIC TUBE FOR OPERATOR'S MANUAL
14	NC01-04-0003	3	CARR. BOLT GR2 ZINC 1/4-20 X 3/4"
15	NC02-25-0007	3	WASHER ZINC 0.281 = 9/32
16	NC01-96-0009	11	NYLON-INSERT LOCKNUT ZINC 1/4-20
17	NC02-32-0011	8	LOCK WASHER ZINC 5/16"
18	NC02-07-0017	8	HEX. NUT 5/16-18
19	NC01-04-0056	4	CARR. BOLT 5/16-18 X3/4"
20	NC02-50-0112	2	HEX. BOLT GR2 ZINC 3/8-16 X 4 1/2"
21	NC01-96-0011	2	NYLON NUT 3/8-16
22	NC01-17-0058	4	HEX. BOLT GR2 ZINC 5/16-18 X 3/4" LG
23	39-98-0631	1	OPERATOR'S MANUAL
24	NC01-04-0002	5	CARR. BOLT GR2 ZINC 1/4-20 X 5/8"
25	39-57-0536	1	HYDROSTATIC POMP GUARD GROUP (STICKER INCLUDED)
26	NC01-04-0001	3	CARR. BOLT GR2 ZINC 1/4-20 X1/2"

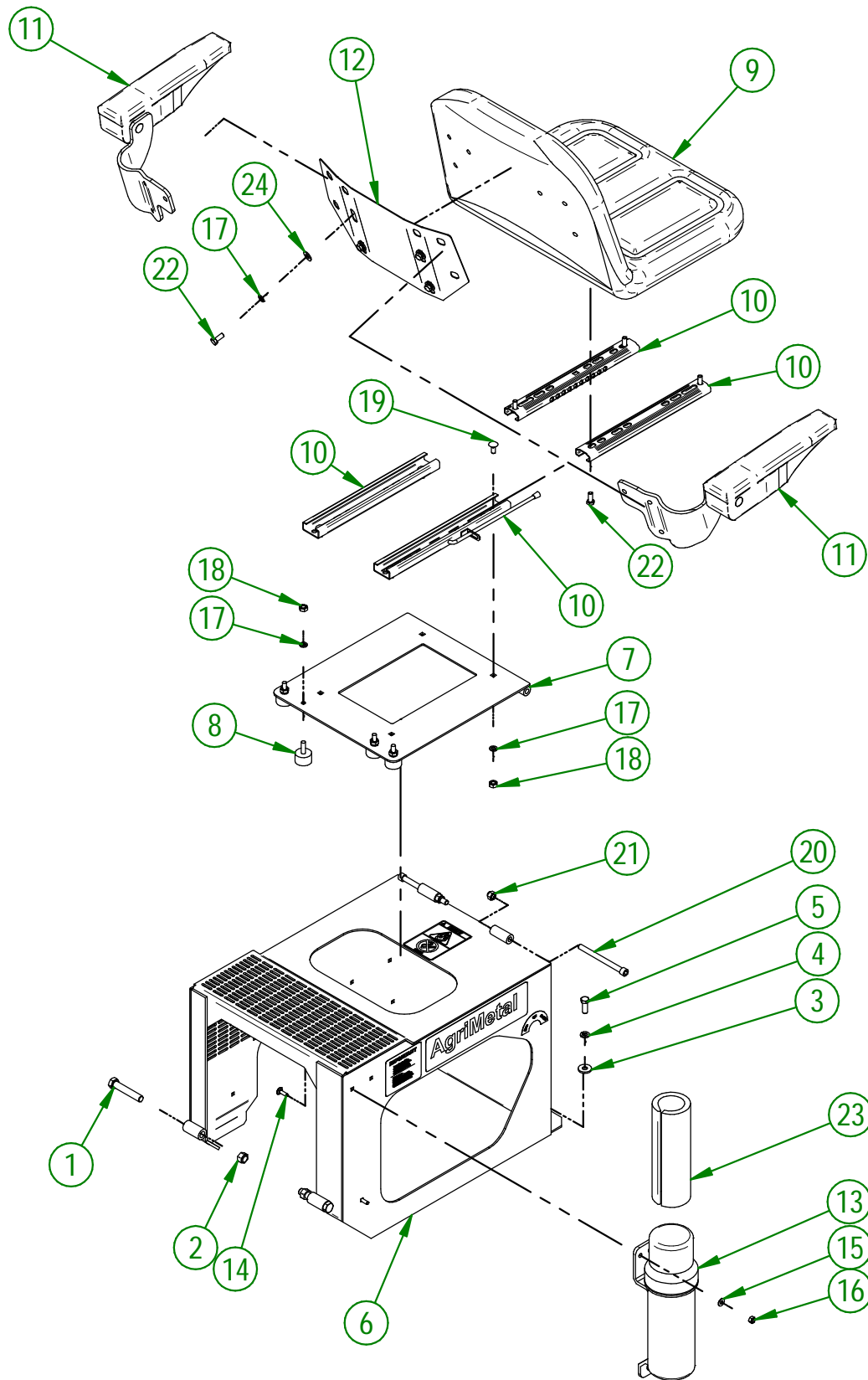

USE THESE PIECES ONLY IF YOUR SERIAL  
NUMBER IS AFFECTED:

BETWEEN #42833 AND #43770

<b>AGRIMETAL</b>	
<b>ENGINE COVER GROUP</b>	
CREATION : 02/03/23	ASSEMBLY : <b>39-57-0543</b>
REVISION : 02/03/23	AUTHOR : D. CHASSÉ

## 39-57-0543

#	PART #	Qty	TITLE
1	NC01-17-0254	2	HEX. BOLT GR2 ZINC 1/2-13 X 2 1/2"
2	NC01-96-0014	2	NYLON-INSERT LOCKNUT ZINC 1/2-13
3	21-01-0950	2	FLAT WASHER 10GA 1.005" DIA X 25/64"
4	NC02-32-0012	2	LOCK WASHER ZINC 3/8"
5	NC01-17-0114	2	HEX. BOLT GR2 ZINC 3/8-16 X 1"
6	39-57-0010	1	ENGINE COVER
7	39-50-0115	1	SEAT FOLDER HOLDER
8	NC13-15-0034	4	RUBBER ABSORBER
9	NC13-80-0200	1	SEAT
10	NC13-80-0201	1	SET OF SEAT RAIL
11	NC13-80-0295	1	ARMRESTS
12	39-01-0400	1	BACK REST SEAT REINFORCEMENT
13	NC13-30-0237	1	PLASTIC TUBE FOR OPERATOR'S MANUAL
14	NC01-04-0003	3	CARR. BOLT GR2 ZINC 1/4-20 X 3/4"
15	NC02-25-0007	3	WASHER ZINC 0.281 = 9/32
16	NC01-96-0009	3	NYLON-INSERT LOCKNUT ZINC 1/4-20
17	NC02-32-0011	12	LOCK WASHER ZINC 5/16"
18	NC02-07-0017	8	HEX. NUT 5/16-18
19	NC01-04-0056	4	CARR. BOLT 5/16-18 X3/4"
20	NC02-50-0112	2	HEX. BOLT GR2 ZINC 3/8-16 X 4 1/2"
21	NC01-96-0011	2	NYLON NUT 3/8-16
22	NC01-17-0058	8	HEX. BOLT GR2 ZINC 5/16-18 X 3/4" LG
23	39-98-0631	1	OPERATOR'S MANUAL
24	01-01-2485	4	FLAT WASHER 14 GA X 13/16"OD X 25/64" ID



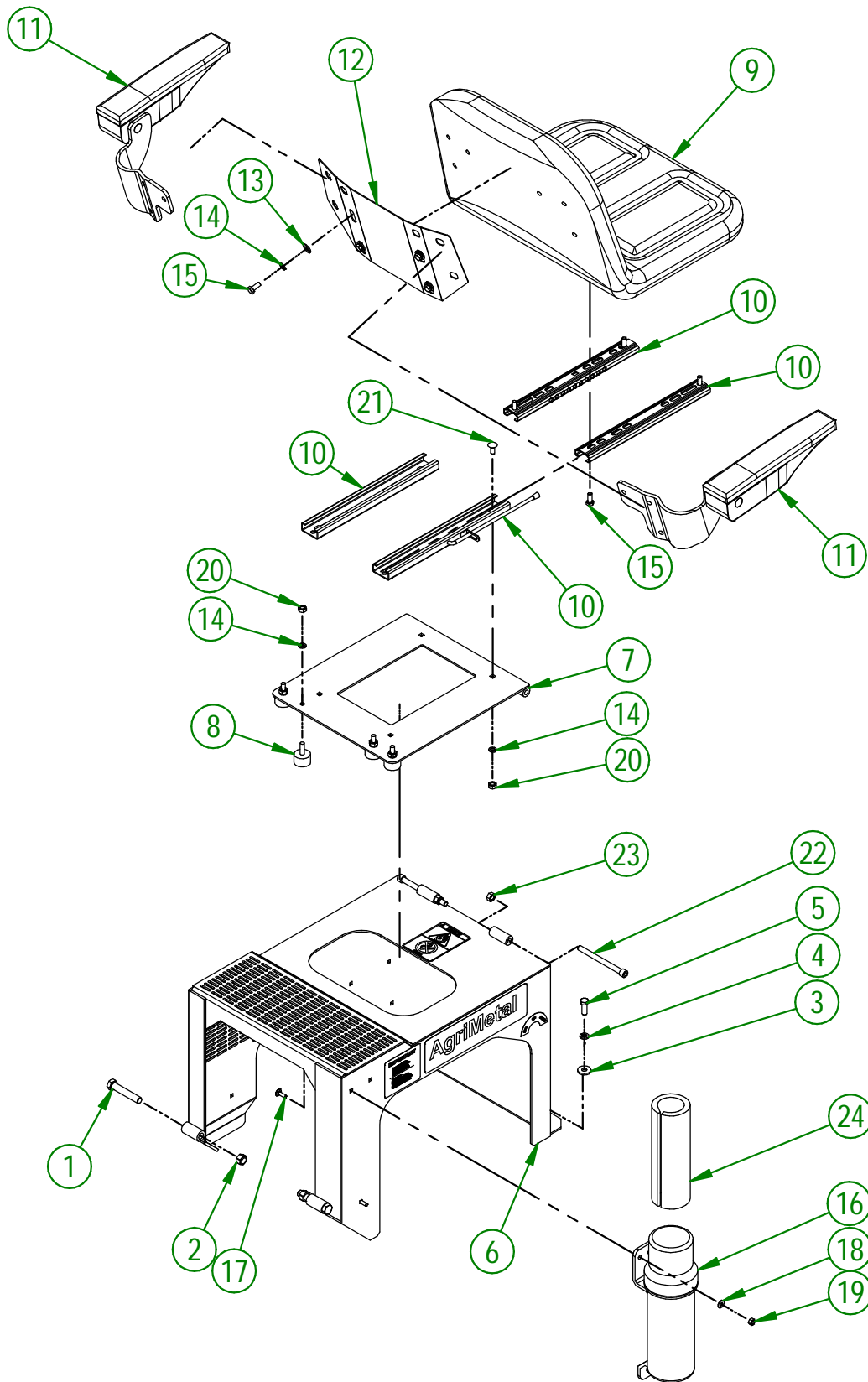

USE THESE PIECES ONLY IF YOUR SERIAL  
NUMBER IS AFFECTED:

#43771 AND UP

<b>AGRIMETAL</b>	
<b>ENGINE COVER GROUP</b>	
CREATION : 01/03/23	ASSEMBLY : <b>39-57-0544</b>
REVISION : 06/03/23	AUTHOR : D. CHASSÉ

## 39-57-0544

#	PART #	Qty	TITLE
1	NC01-17-0254	2	HEX. BOLT GR2 ZINC 1/2-13 X 2 1/2"
2	NC01-96-0014	2	NYLON-INSERT LOCKNUT ZINC 1/2-13
3	21-01-0950	2	FLAT WASHER 10GA 1.005" DIA X 25/64"
4	NC02-32-0012	2	LOCK WASHER ZINC 3/8"
5	NC01-17-0114	2	HEX. BOLT GR2 ZINC 3/8-16 X 1"
6	39-57-0011	1	ENGINE COVER
7	39-50-0115	1	SEAT FOLDER HOLDER
8	NC13-15-0034	4	RUBBER ABSORBER
9	NC13-80-0200	1	SEAT
10	NC13-80-0201	1	SET OF SEAT RAIL
11	NC13-80-0295	1	ARMRESTS
12	39-01-0400	1	BACK REST SEAT REINFORCEMENT
13	01-01-2485	4	FLAT WASHER 14 GA X 13/16"OD X 25/64" ID
14	NC02-32-0011	12	LOCK WASHER ZINC 5/16"
15	NC01-17-0058	8	HEX. BOLT GR2 ZINC 5/16-18 X 3/4" LG
16	NC13-30-0237	1	PLASTIC TUBE FOR OPERATOR'S MANUAL
17	NC01-04-0003	3	CARR. BOLT GR2 ZINC 1/4-20 X 3/4"
18	NC02-25-0007	3	WASHER ZINC 0.281 = 9/32
19	NC01-96-0009	3	NYLON-INSERT LOCKNUT ZINC 1/4-20
20	NC02-07-0017	8	HEX. NUT 5/16-18
21	NC01-04-0056	4	CARR. BOLT 5/16-18 X3/4"
22	NC02-50-0112	2	HEX. BOLT GR2 ZINC 3/8-16 X 4 1/2"
23	NC01-96-0011	2	NYLON NUT 3/8-16
24	39-98-0631	1	OPERATOR'S MANUAL

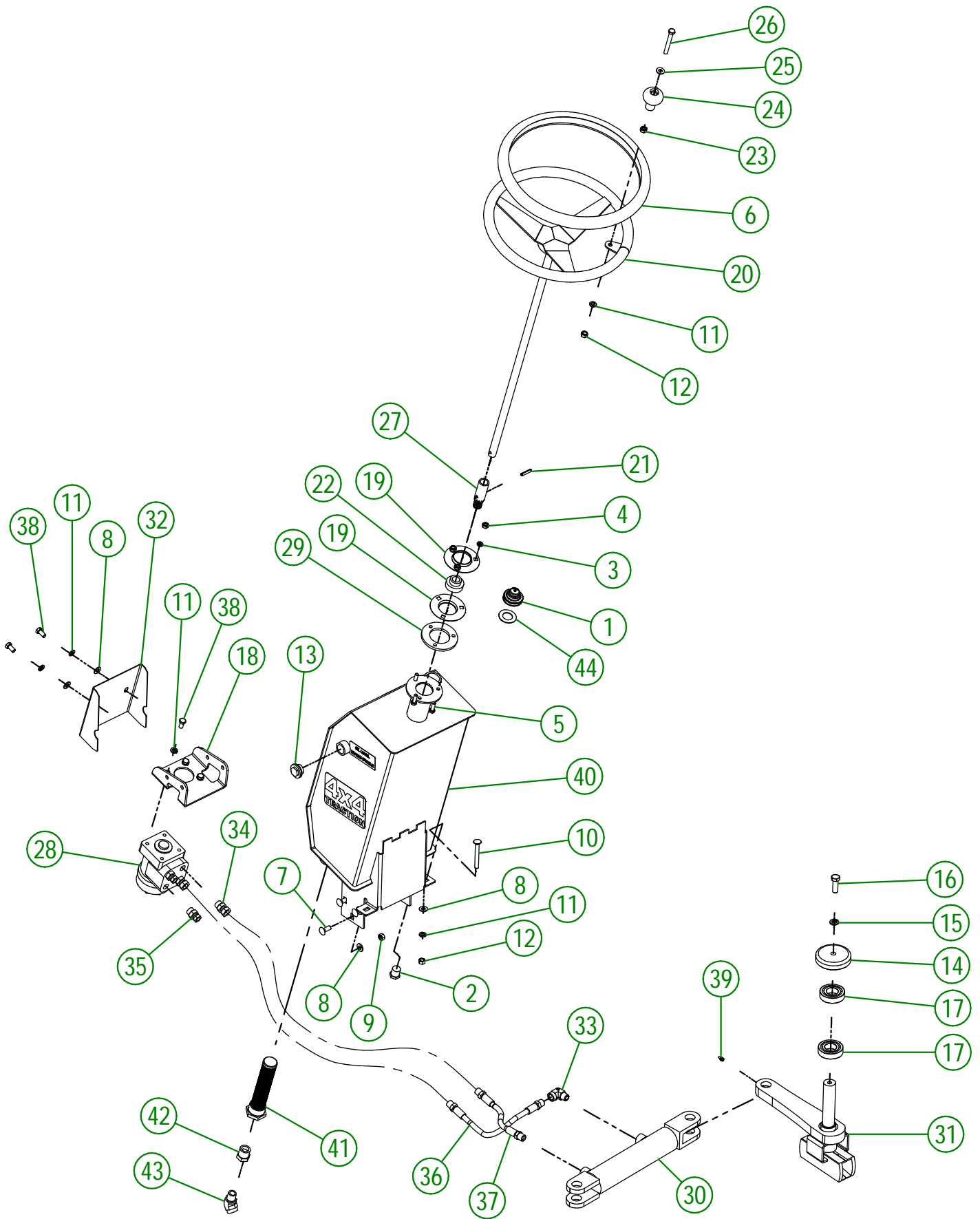

USE THESE PIECES ONLY IF YOUR SERIAL NUMBER IS AFFECTED:

#43770 AND UNDER

<b>AGRIMETAL</b>	
<b>STEERING SYSTEM GROUP</b>	
CREATION : 10/02/22	ASSEMBLY : <b>39-57-0547</b>
REVISION : 10/03/23	AUTHOR : J. Houle

39-57-0547

#	PART #	Qty	TITLE
1	NC13-37-0121	1	TANK CAP
2	NC13-45-0015	1	HEX. CAP 1/2 NPTF MALE
3	NC02-32-0011	3	LOCK WASHER ZINC 5/16"
4	NC02-07-0017	3	HEX. NUT 5/16-18
5	NC01-17-0060	3	HEX. BOLT GR2 ZINC 5/16-18 X 1"
6	NC13-80-0254	1	STEERING WHEEL COVER
7	NC01-04-0109	6	CARR. BOLT GR2 ZINC 3/8-16 X 1"
8	01-01-2485	10	FLAT WASHER 14 GA X 13/16"OD X 25/64" ID
9	NC01-93-0011	6	LOCK NUT 3/8-16
10	NC01-04-0117	2	CARR. BOLT GR2 NC ZINC 3/8-16 X 3"
11	NC02-32-0012	9	LOCK WASHER ZINC 3/8"
12	NC02-07-0018	3	HEX. NUT ZINC 3/8-16
13	NC01-76-0001	1	SIGHT GLASS 3/4 NPT
14	39-21-0000	1	STEERING PLATE SHAFT COVER
15	NC02-32-0014	1	LOCK WASHER ZINC 1/2"
16	NC01-17-0249	1	HEX. BOLT GR2 ZINC 1/2-13 X 1 1/2"
17	NC14-75-0091	2	6206 ZZ BEARING
18	39-04-0195	1	HYDRAULIQUE CONTROL SUPPORT
19	NC14-75-0008	2	STEEL BEARING ONLY 3 HOLES F4 3 9/16" OD
20	39-50-0081	1	STEERING WHEEL
21	NC01-69-0459	1	ZINC SPRING PIN TENDER DIA. 1/4" X 1 1/4"
22	NC14-75-0014	1	STEEL BEARING SB 204-12 X 3/4" ID
23	NC01-96-0011	1	NYLON NUT 3/8-16
24	NC17-46-0018	1	HANDLE KNOB
25	NC17-57-0016	1	FLAT WASHER 14 GA X 13/16"OD X 25/64" ID
26	NC01-17-0122	1	HEX. BOLT GR2 ZINC 3/8-16 X 3"
27	39-20-0005	1	STEERING SHAFT ADAPTER
28	NC14-45-0151	1	HYDRAULIC STEERING ASSIST
29	39-04-0275	1	STEERING SHAFT BEARING SUPPORT
30	NC13-45-0370	1	HYDRAULIC CYLINDER 6"
31	39-50-0571	1	STEERING PLATE
32	39-01-0080	1	STEERING SHAFT GUARD
33	NC13-45-0038	1	ELBOW 90 3/8 FEM. NPT X 3/8 MALE NPT
34	NC13-45-0036	2	STRAIGHT REDUCER 3/4-16 MALE SAE8 O RING X 1/4 FEMALE
35	NC13-45-0204	2	STRAIGHT REDUCER 3/4-16 MALE SAE8 O RING X 1/4 FEMALE
36	NC17-02-0422	1	HYDRAULIC HOSE (13" LG)
37	NC17-02-0421	1	HYDRAULIC HOSE (10" LG)
38	NC01-17-0112	6	HEX. BOLT GR2 ZINC 3/8-16 X 3/4"
39	NC01-69-0785	1	STRAIGHT GREASE FITTING 1/4-28
40	39-57-0142	1	OIL TANK
41	NC13-45-0381	1	TANK STRAINER
42	NC13-45-0032	1	STRAIGHT HOSE FITTING 1/2 FEM. NPT X 3/4 MALE NPT
43	NC13-45-0086	1	ELBOW 45 1/2 FEM. NPT X 1/2 MALE NPT
44	NC13-15-0352	1	RUBBER FLAT WASHER

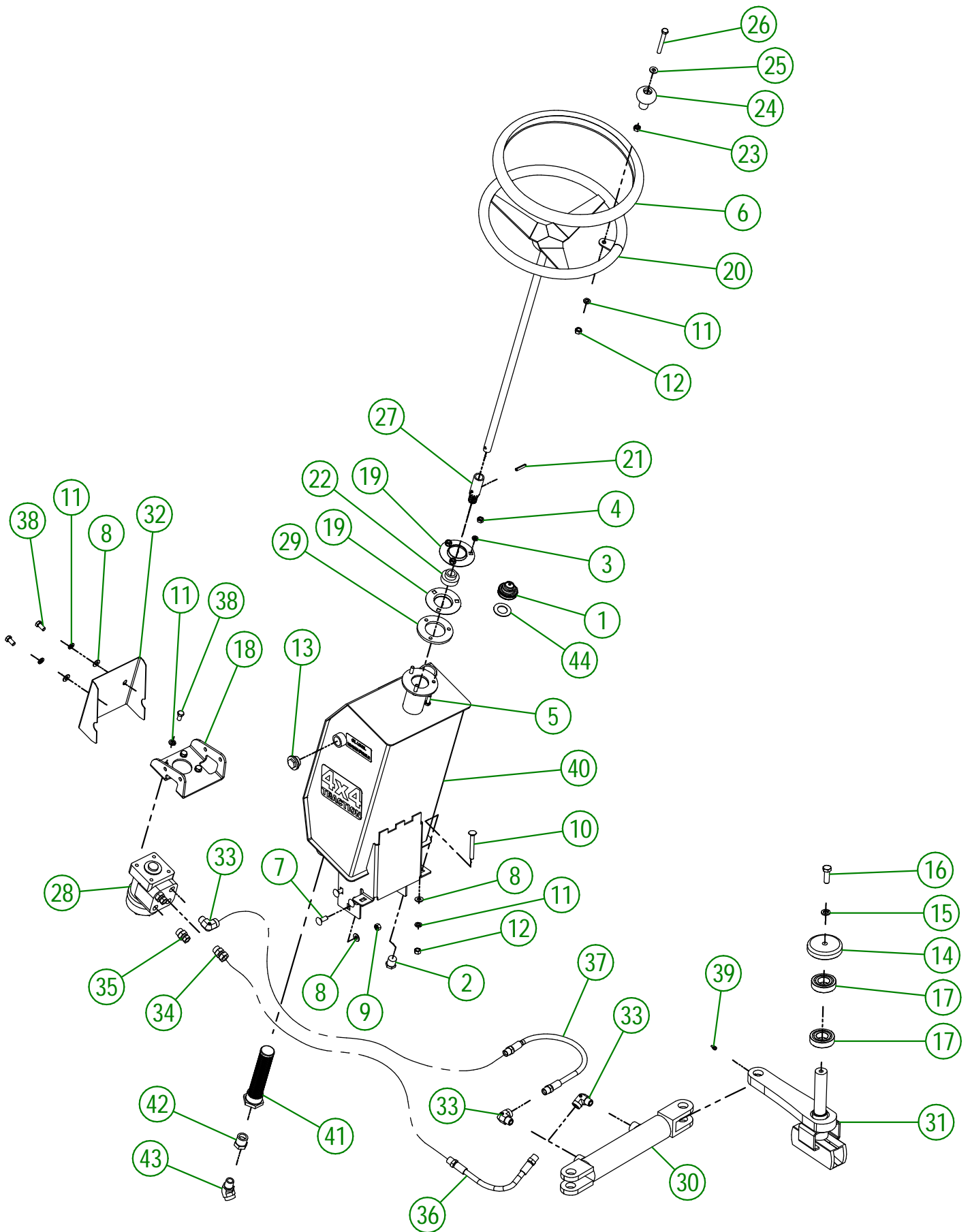

USE THESE PIECES ONLY IF YOUR SERIAL NUMBER IS AFFECTED:

#43771 AND ABOVE

**AGRIMETAL**  
STEERING SYSTEM GROUP

CREATION : 10/03/23  
REVISION : 10/03/23

ASSEMBLY : **39-57-0548**  
AUTHOR : J. Houle

39-57-0548

#	PART #	Qty	TITLE
1	NC13-37-0121	1	TANK CAP
2	NC13-45-0015	1	HEX. CAP 1/2 NPTF MALE
3	NC02-32-0011	3	LOCK WASHER ZINC 5/16"
4	NC02-07-0017	3	HEX. NUT 5/16-18
5	NC01-17-0060	3	HEX. BOLT GR2 ZINC 5/16-18 X 1"
6	NC13-80-0254	1	STEERING WHEEL COVER
7	NC01-04-0109	6	CARR. BOLT GR2 ZINC 3/8-16 X 1"
8	01-01-2485	10	FLAT WASHER 14 GA X 13/16"OD X 25/64" ID
9	NC01-93-0011	6	LOCK NUT 3/8-16
10	NC01-04-0117	2	CARR. BOLT GR2 NC ZINC 3/8-16 X 3"
11	NC02-32-0012	9	LOCK WASHER ZINC 3/8"
12	NC02-07-0018	3	HEX. NUT ZINC 3/8-16
13	NC01-76-0001	1	SIGHT GLASS 3/4 NPT
14	39-21-0000	1	STEERING PLATE SHAFT COVER
15	NC02-32-0014	1	LOCK WASHER ZINC 1/2"
16	NC01-17-0249	1	HEX. BOLT GR2 ZINC 1/2-13 X 1 1/2"
17	NC14-75-0091	2	6206 ZZ BEARING
18	39-04-0195	1	HYDRAULIQUE CONTROL SUPPORT
19	NC14-75-0008	2	STEEL BEARING ONLY 3 HOLES F4 3 9/16" OD
20	39-50-0081	1	STEERING WHEEL
21	NC01-69-0459	1	ZINC SPRING PIN TENDER DIA. 1/4" X 1 1/4"
22	NC14-75-0014	1	STEEL BEARING SB 204-12 X 3/4" ID
23	NC01-96-0011	1	NYLON NUT 3/8-16
24	NC17-46-0018	1	HANDLE KNOB
25	NC17-57-0016	1	FLAT WASHER 14 GA X 13/16"OD X 25/64" ID
26	NC01-17-0122	1	HEX. BOLT GR2 ZINC 3/8-16 X 3"
27	39-20-0005	1	STEERING SHAFT ADAPTER
28	NC14-45-0151	1	HYDRAULIC STEERING ASSIST
29	39-04-0275	1	STEERING SHAFT BEARING SUPPORT
30	NC13-45-0370	1	HYDRAULIC CYLINDER 6"
31	39-50-0571	1	STEERING PLATE
32	39-01-0080	1	STEERING SHAFT GUARD
33	NC13-45-0038	3	ELBOW 90 3/8 FEM. NPT X 3/8 MALE NPT
34	NC13-45-0036	1	STRAIGHT REDUCER 3/4-16 MALE SAE8 O RING X 1/4 FEMALE
35	NC13-45-0204	2	STRAIGHT REDUCER 3/4-16 MALE SAE8 O RING X 1/4 FEMALE
36	NC17-02-0422	1	HYDRAULIC HOSE (13" LG)
37	NC17-02-0421	1	HYDRAULIC HOSE (10" LG)
38	NC01-17-0112	6	HEX. BOLT GR2 ZINC 3/8-16 X 3/4"
39	NC01-69-0785	1	STRAIGHT GREASE FITTING 1/4-28
40	39-57-0142	1	OIL TANK
41	NC13-45-0381	1	TANK STRAINER
42	NC13-45-0032	1	STRAIGHT HOSE FITTING 1/2 FEM. NPT X 3/4 MALE NPT
43	NC13-45-0086	1	ELBOW 45 1/2 FEM. NPT X 1/2 MALE NPT
44	NC13-15-0352	1	RUBBER FLAT WASHER

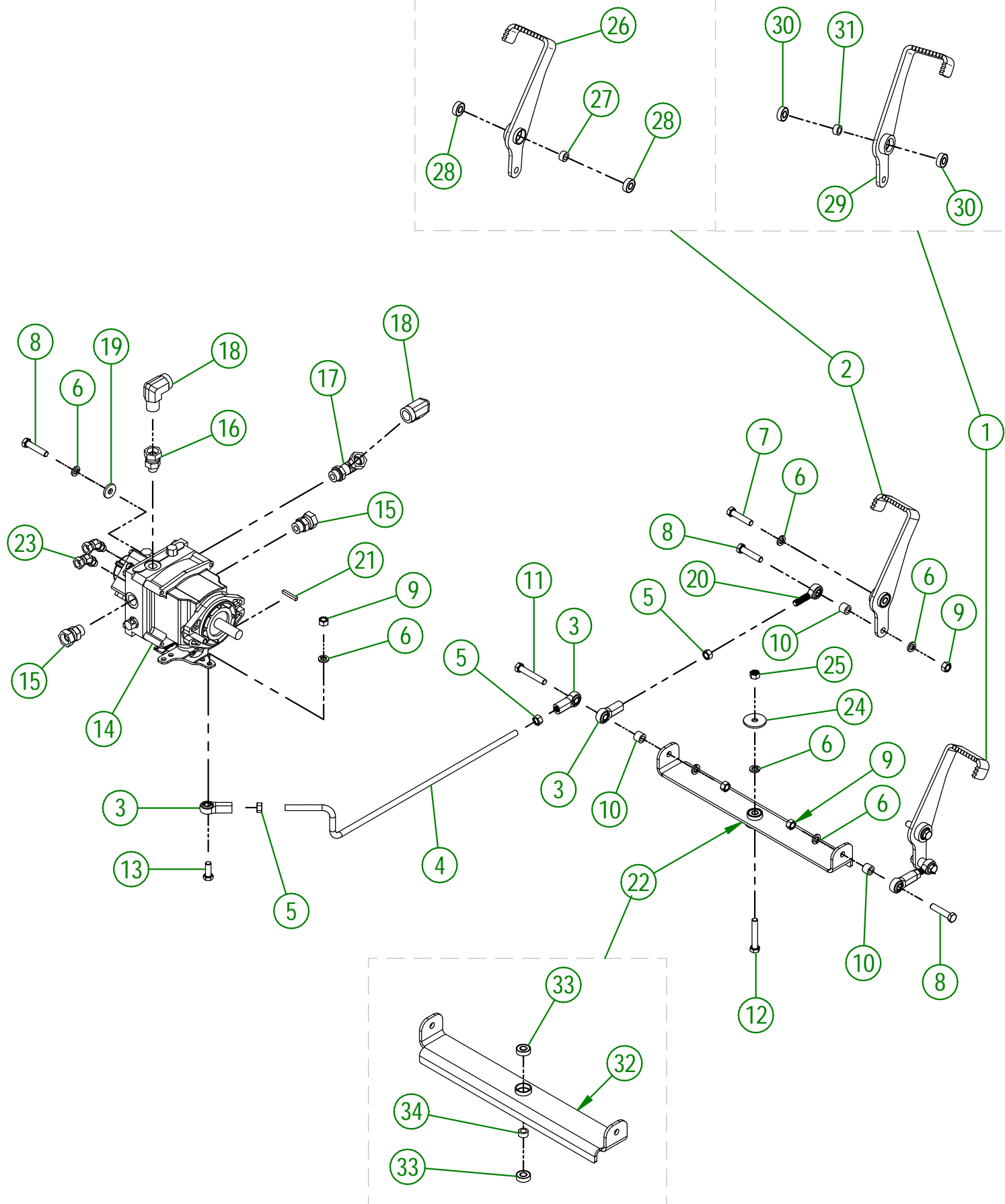

USE THESE PIECES ONLY IF YOUR SERIAL NUMBER IS AFFECTED:

#42960 AND UNDER

<b>AGRIMETAL</b>	
HYDROSTATIC SYSTEM GROUP	
CREATION : 10/02/22	ASSEMBLY : <b>39-57-0099</b>
REVISION : 02/11/22	AUTHOR : J. Houle

## 39-57-0099

#	PART #	Qty	TITLE
1	39-55-0026	1	RIGHT PEDAL
2	39-55-0021	1	LEFT PEDAL
3	NC01-67-0104	4	INTERNALLY THREADED BALL JOINT ROD ENDS 3/8-24
4	39-13-0401	1	HYDROSTATIC CONTROL ROD
5	NC02-10-0018	4	NUT 3/8-24
6	NC02-32-0012	10	LOCK WASHER ZINC 3/8"
7	NC01-33-0117	2	CARR. BOLT GR8 ZINC 3/8-16 X 1 3/4"
8	NC01-17-0117	5	HEX. BOLT GR2 ZINC 3/8-16 X 1 3/4"
9	NC02-07-0018	5	HEX. NUT ZINC 3/8-16
10	39-09-0050	4	PEDAL SYSTEM BUSHING
11	NC01-17-0119	1	HEX. BOLT GR2 ZINC 3/8-16 X 2 1/4"
12	NC01-37-0119	1	CARR. BOLT GR8 ZINC 3/8-24 X 2 1/4"
13	NC01-17-0114	1	HEX. BOLT GR2 ZINC 3/8-16 X 1"
14	NC14-45-0153	1	HYDROSTATIC MOTOR
15	NC13-45-0106	2	STRAIGHT REDUCER 3/4-16 MALE SAE8 O RING X 1/2 FEMALE
16	NC13-45-0220	1	STRAIGHT 9/16 MALE ORING X 1/2 FEMALE NPT
17	NC13-45-0203	1	ELBOW 90° 3/4 MALE ORING X 1/2 FEMALE NPT
18	NC13-45-0025	2	ELBOW 90° 1/2 FEMALE NPT X 1/2 MALE NPT
19	21-01-0950	2	FLAT WASHER IOGA 1.005" DIA X 25/64"
20	NC01-67-0304	2	BALL JOINTS ROD ENDS 3/8-24
21	01-41-0905	1	SQUARE KEY 3/16" X 1 1/4"TL
22	39-55-0046	1	PEDAL JUNCTION ARM
23	NC13-45-0372	2	FITTING 45° 7/16-20 MALE O RING SAE4 X 1/4 FEM. TOUR.NPT
24	01-33-0010	1	WASHER
25	NC01-94-0011	1	LOCK NUT 3/8-24

## 39-55-0021

#	PART #	Qty	TITLE
26	39-50-0111	1	LEFT PEDAL
27	01-09-0005	1	BUSHING
28	NC14-75-0153	2	BALL BEARING R6 2RS 3/8" X 7/8" X 0.281"

## 39-55-0026

#	PART #	Qty	TITLE
29	39-50-0106	1	RIGHT PEDAL
30	NC14-75-0153	2	BALL BEARING R6 2RS 3/8" X 7/8" X 0.281"
31	01-09-0005	1	BUSHING

## 39-55-0046

#	PART #	Qty	TITLE
32	39-50-0041	1	PEDALS UNION
33	NC14-75-0153	2	BALL BEARING R6 2RS 3/8" X 7/8" X 0.281"
34	01-09-0005	1	BUSHING



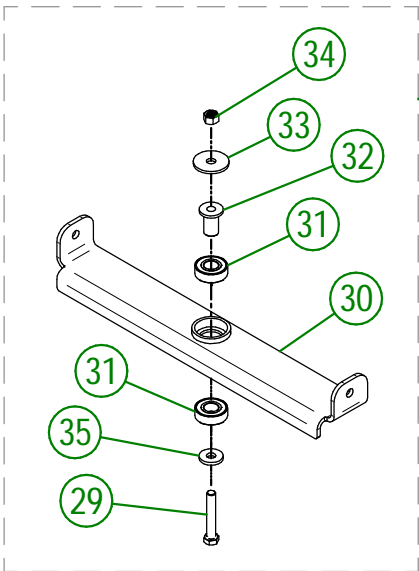
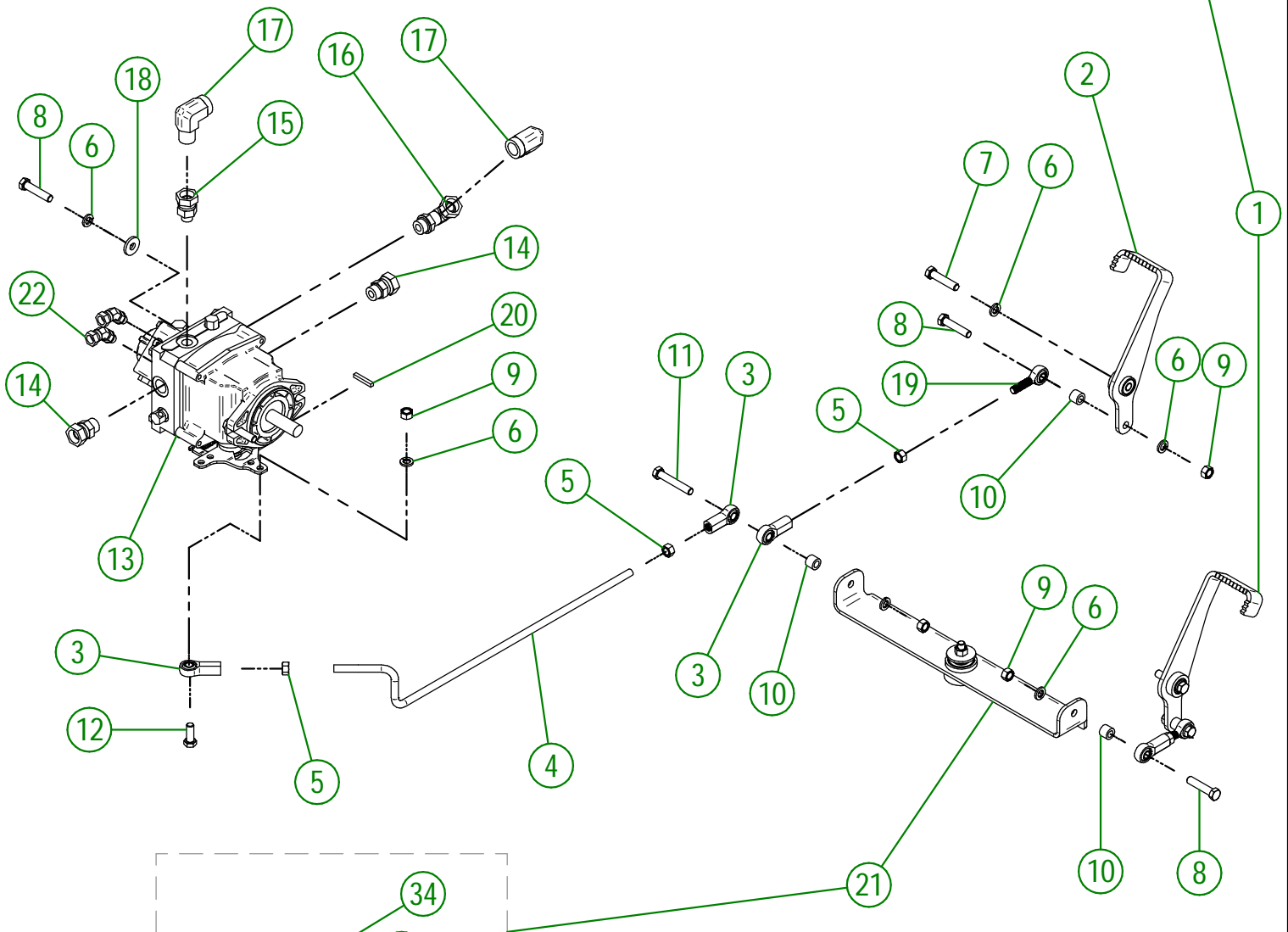
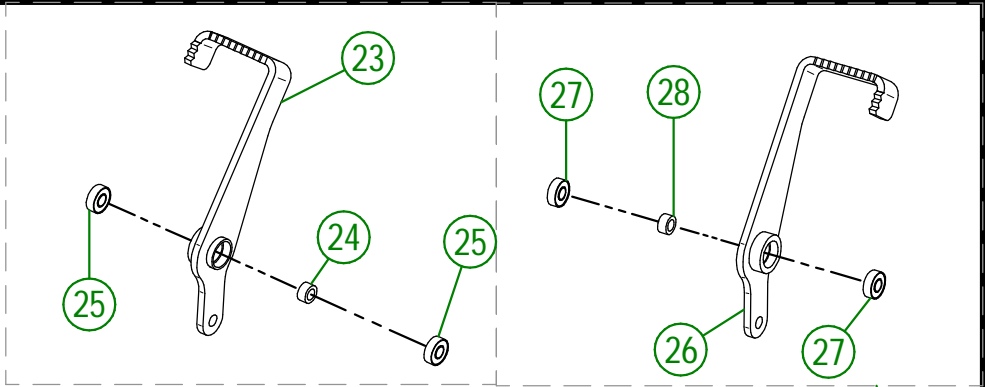

USE THESE PIECES ONLY IF YOUR SERIAL NUMBER IS AFFECTED:

#42961 AND ABOVE

<b>AGRIMETAL</b>	
HYDROSTATIC SYSTEM GROUP	
CREATION : 07/09/22	ASSEMBLY : <b>39-57-0400</b>
REVISION : 02/11/22	AUTHOR : D. CHASSÉ

## 39-57-0400

#	PART #	Qty	TITLE
1	39-55-0026	1	RIGHT PEDAL
2	39-55-0021	1	LEFT PEDAL
3	NC01-67-0104	4	INTERNALLY THREADED BALL JOINT ROD ENDS 3/8-24
4	39-13-0401	1	HYDROSTATIC CONTROL ROD
5	NC02-10-0018	4	NUT 3/8-24
6	NC02-32-0012	9	LOCK WASHER ZINC 3/8"
7	NC01-33-0117	2	CARR. BOLT GR8 ZINC 3/8-16 X 1 3/4"
8	NC01-17-0117	5	HEX. BOLT GR2 ZINC 3/8-16 X 1 3/4"
9	NC02-07-0018	5	HEX. NUT ZINC 3/8-16
10	39-09-0050	4	PEDAL SYSTEM BUSHING
11	NC01-17-0119	1	HEX. BOLT GR2 ZINC 3/8-16 X 2 1/4"
12	NC01-17-0114	1	HEX. BOLT GR2 ZINC 3/8-16 X 1"
13	NC14-45-0153	1	HYDROSTATIC MOTOR
14	NC13-45-0106	2	STRAIGHT REDUCER 3/4-16 MALE SAE8 O RING X 1/2 FEMALE
15	NC13-45-0220	1	STRAIGHT 9/16 MALE ORING X 1/2 FEMALE NPT
16	NC13-45-0203	1	ELBOW 90° 3/4 MALE ORING X 1/2 FEMALE NPT
17	NC13-45-0025	2	ELBOW 90° 1/2 FEMALE NPT X 1/2 MALE NPT
18	21-01-0950	2	FLAT WASHER 10GA 1.005" DIA X 25/64"
19	NC01-67-0304	2	BALL JOINTS ROD ENDS 3/8-24
20	01-41-0905	1	SQUARE KEY 3/16" X 1 1/4"TL
21	39-57-0220	1	PEDAL JUNCTION ARM
22	NC13-45-0372	2	FITTING 45° 7/16-20 MALE O RING SAE4 X 1/4 FEM. TOUR.NPT

## 39-55-0021

#	PART #	Qty	TITLE
23	39-50-0111	1	LEFT PEDAL
24	01-09-0005	1	BUSHING
25	NC14-75-0153	2	BALL BEARING R6 2RS 3/8" X 7/8" X 0.281"

## 39-55-0026

#	PART #	Qty	TITLE
26	39-50-0106	1	RIGHT PEDAL
27	NC14-75-0153	2	BALL BEARING R6 2RS 3/8" X 7/8" X 0.281"
28	01-09-0005	1	BUSHING

## 39-57-0220

#	PART #	Qty	TITLE
29	NC01-37-0119	1	CARR. BOLT GR8 ZINC 3/8-24 X 2 1/4"
30	39-50-0042	1	PEDALS UNION
31	NC14-75-0068	2	BALL BEARING 99502H
32	39-13-0200	1	JONCTION ARM PIVOT
33	01-33-0010	1	WASHER
34	NC01-94-0011	1	LOCK NUT 3/8-24
35	21-01-0950	1	FLAT WASHER 10GA 1.005" DIA X 25/64"

39-57-0210

#	PART #	Qty	TITLE
1	26-03-4800	4	WASHER
2	NC13-15-0068	2	GREEN RUBBER BASE MOUNT
3	NC13-15-0059	2	YELLOW RUBBER BASE MOUNT
4	01-33-0010	8	WASHER
5	NC01-17-0123	4	HEX. BOLT GR2 ZINC 3/8-16 X 3 1/4"
6	01-01-2485	4	FLAT WASHER 14 GA X 13/16"OD X 25/64" ID
7	NC02-32-0012	4	LOCK WASHER ZINC 3/8"
8	NC02-07-0018	4	HEX. NUT ZINC 3/8-16
9	NC14-05-0029	1	COUPLING (LOVEJOY) CXL100 X 1" ID
10	NC14-05-0030	1	COUPLING (LOVEJOY) RUBBER N100
11	39-46-3500	1	HYDROSTATIC COUPLING HUB

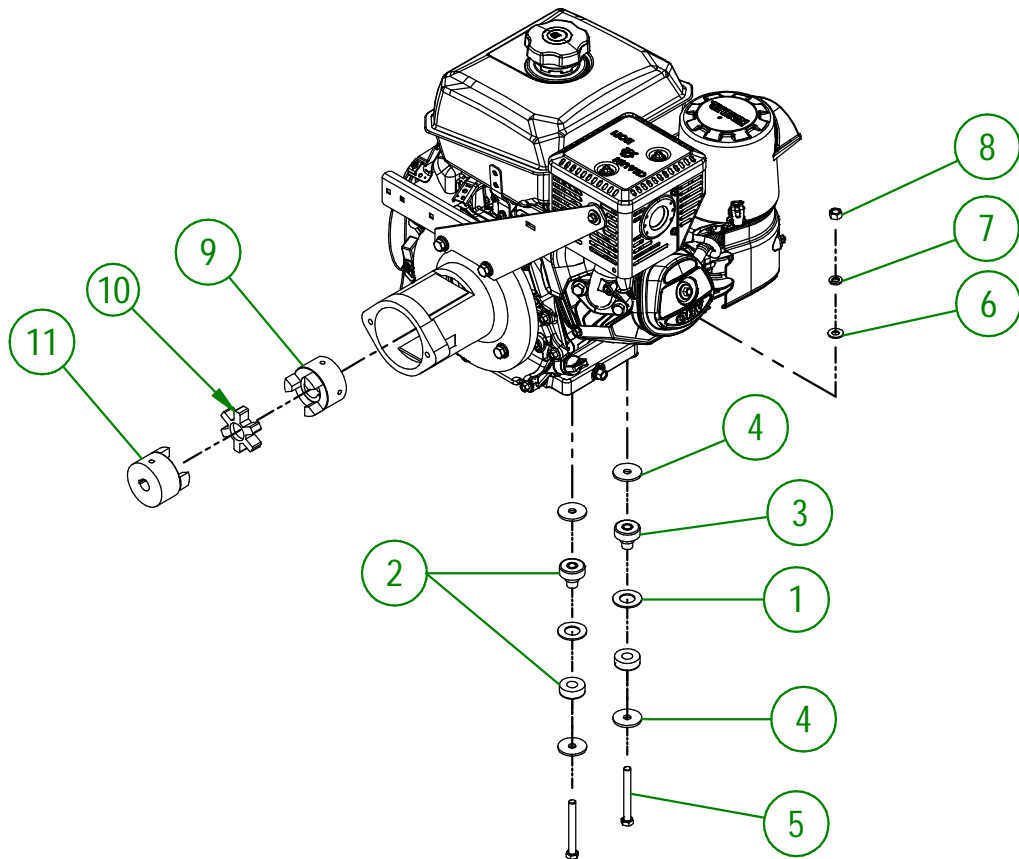

USE THESE PIECES ONLY IF YOUR SERIAL NUMBER IS AFFECTED:

#43770 AND LESS

<b>AGRIMETAL</b>	
<b>KOHLER MOTOR GROUP</b>	
CREATION : 15/02/22	ASSEMBLY : <b>39-57-0210</b>
REVISION : 02/03/23	AUTHOR : Dessin1

#	PART #	Qty	TITLE
1	26-03-4800	4	WASHER
2	NC13-15-0059	4	YELLOW RUBBER BASE MOUNT
3	01-33-0010	4	WASHER
4	01-01-2485	4	FLAT WASHER 14 GA X 13/16"OD X 25/64" ID
5	NC02-32-0012	8	LOCK WASHER ZINC 3/8"
6	NC02-07-0018	8	HEX. NUT ZINC 3/8-16
7	NC14-05-0029	1	COUPLING (LOVEJOY) CXL100 X 1" ID
8	NC14-05-0030	1	COUPLING (LOVEJOY) RUBBER N100
9	39-46-3500	1	HYDROSTATIC COUPLING HUB
10	39-42-0605	1	GAS THROTTLE EXTENSION
11	NC01-65-0053	2	COLLAR (MH4)
12	39-01-0360	1	MOTOR BASE
13	21-01-0950	4	FLAT WASHER 10GA 1.005" DIA X 25/64"
14	NC01-17-0119	4	HEX. BOLT GR2 ZINC 3/8-16 X 2 1/4"
15	NC01-17-0117	4	HEX. BOLT GR2 ZINC 3/8-16 X 1 3/4"

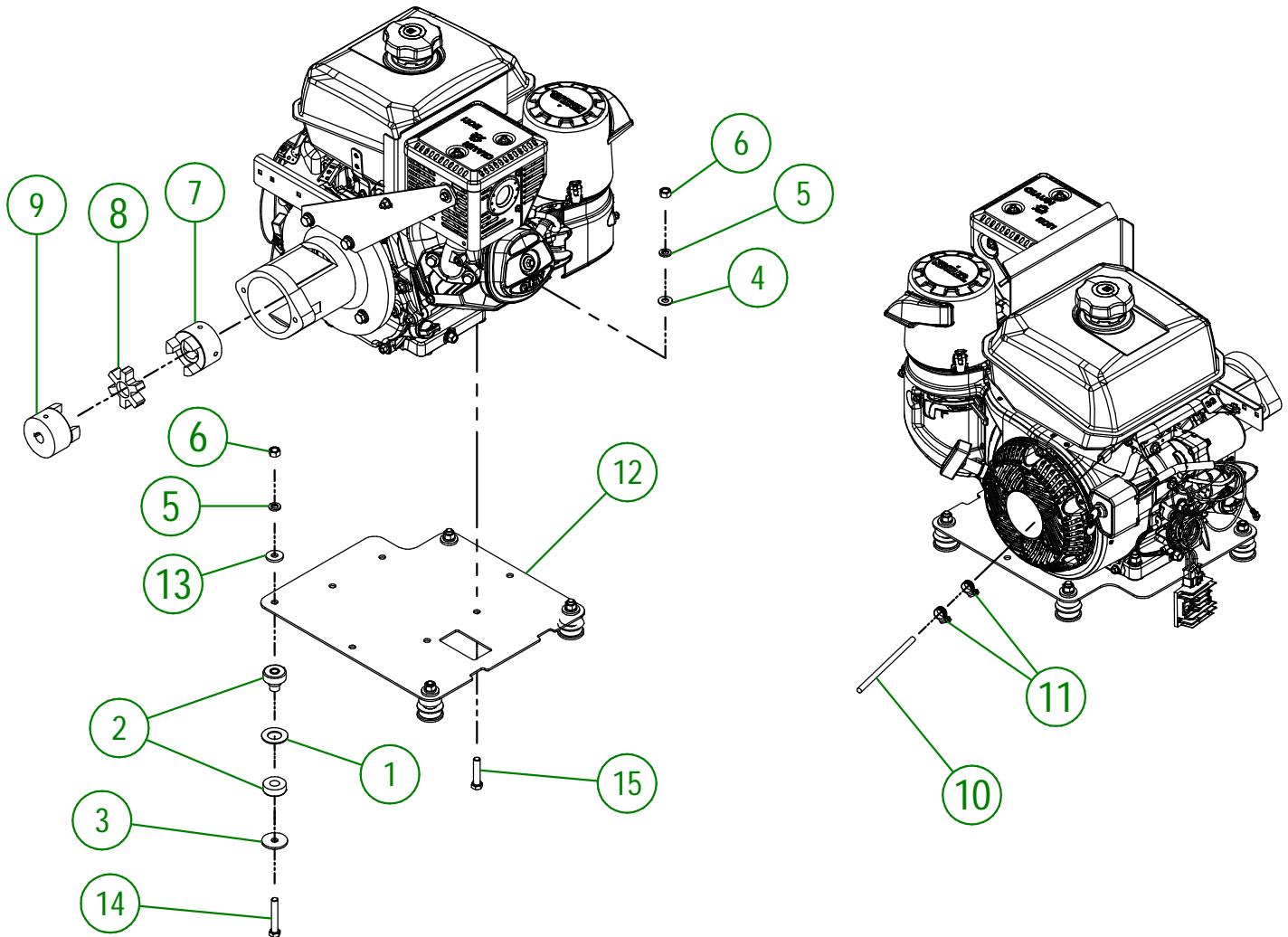

USE THESE PIECES ONLY IF YOUR SERIAL  
NUMBER IS AFFECTED:

#43771 AND UP

**AGRIMETAL**  
**KOHLER MOTOR GROUP**

CREATION : 01/03/23  
REVISION : 06/03/23

ASSEMBLY : **39-57-0211**  
AUTHOR : dessin3

#	PART #	Qty	TITLE
1	39-50-0120	1	FUEL ENGINE ADAPTER FOR HYDROSTATIC PUMP
2	01-01-2485	4	FLAT WASHER 14 GA X 13/16"OD X 25/64" ID
3	NC02-32-0012	4	LOCK WASHER ZINC 3/8"
4	NC01-17-0115	2	HEX. BOLT GR2 ZINC 3/8-16 X 1 1/4"
5	NC01-17-0117	2	HEX. BOLT GR2 ZINC 3/8-16 X 1 3/4"
6	39-01-0310	1	MUFFLER HOLDER
7	21-01-0950	4	FLAT WASHER 10GA 1.005" DIA X 25/64"
8	39-01-2405	1	VOLTAGE REGULATOR HOLDER
9	36-01-2430	1	FLAT WASHER 14GA X 17/64" I.D. X 13/16" O.D.
10	NC02-32-0010	1	LOCK WASHER ZINC 1/4"
11	NC01-45-0116	1	METRIC BOLT GR8.8 NC ZINC 6MM X 25 MM
12	26-21-0098	1	MUFFLER HOLDER RING
13	39-03-0005	1	HEAT SHIELD
14	NC01-04-0003	1	CARR. BOLT GR2 ZINC 1/4-20 X 3/4"
15	NC01-04-0056	1	CARR. BOLT 5/16-18 X3/4"
16	NC02-14-0006	1	HEX. NUT SPECIAL FLANGET NC 5/16-18 B GRADE
17	NC01-93-0001	1	HEX. NUT NC ZINC 1/4-20
18	NC02-22-0008	1	WASHER ZINC 5/16"
19	22-22-2600	2	CARRIAGE BOLT SHIM (5/16")

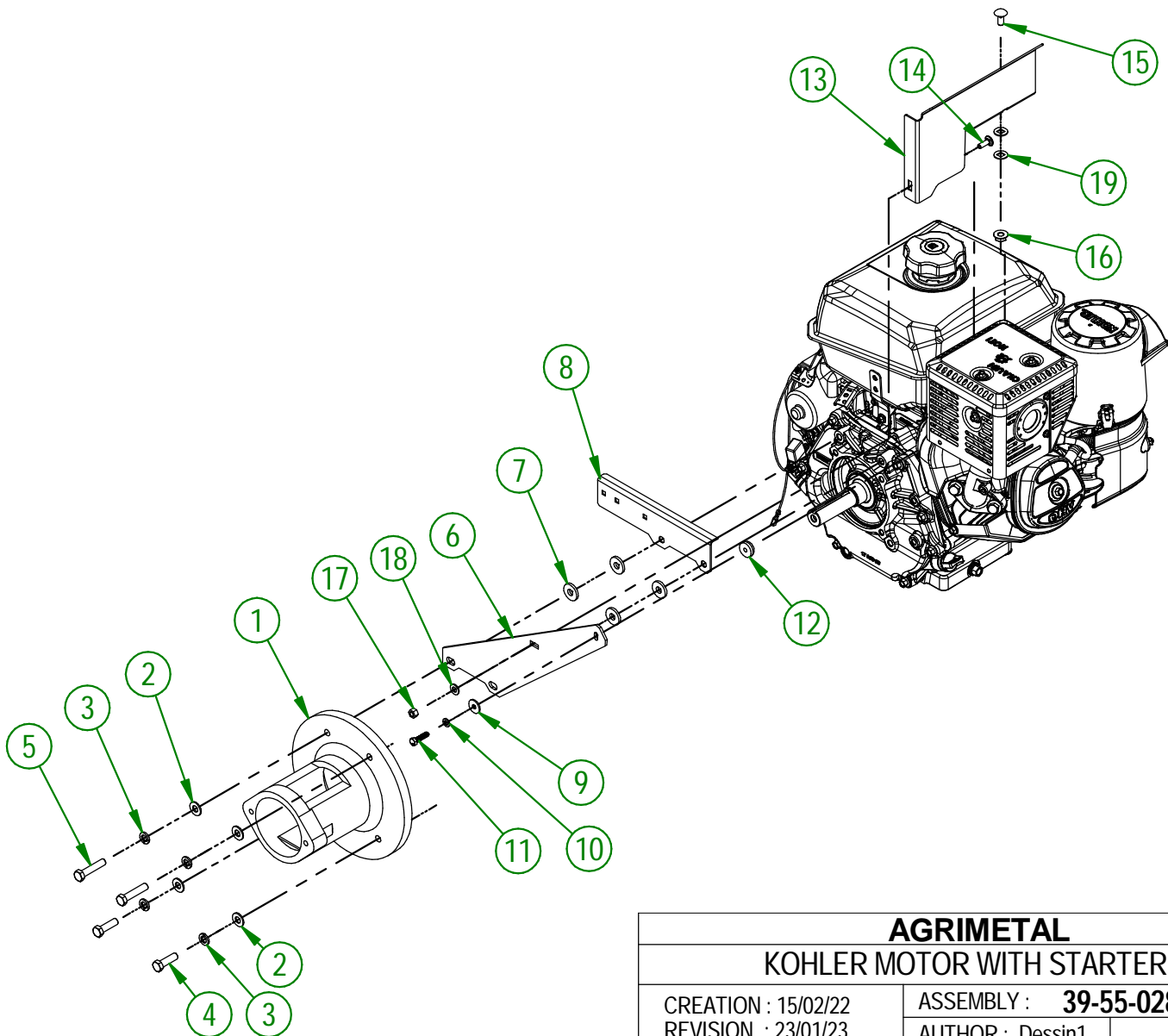

<b>AGRIMETAL</b>	
<b>KOHLER MOTOR WITH STARTER</b>	
CREATION : 15/02/22	ASSEMBLY : <b>39-55-0285</b>
REVISION : 23/01/23	AUTHOR : Dessin1

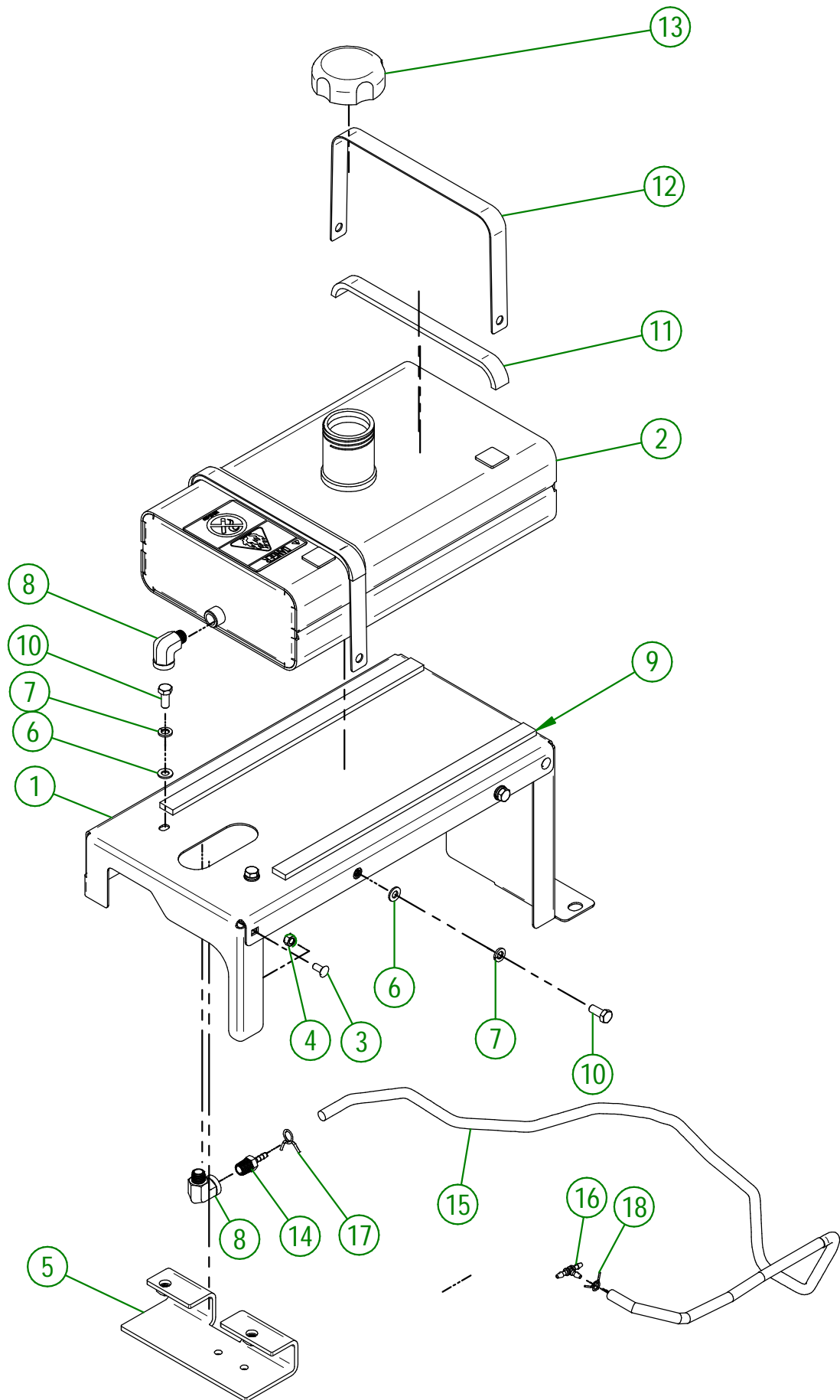

<b>AGRIMETAL</b>	
<b>ADDITIONAL GAS TANK</b>	
CREATION : 07/09/22	ASSEMBLY : <b>39-57-5000</b>
REVISION : 12/09/22	AUTHOR : D. CHASSÉ

## 39-57-5000

#	PART #	Qty	TITLE
1	39-57-5010	1	HYDROLISTATIC PUMP GUARD
2	39-57-5005	1	ALUMINUM GAS TANK
3	NC01-04-0001	5	CARR. BOLT GR2 ZINC 1/4-20 X1/2"
4	NC01-96-0009	5	NYLON-INSERT LOCKNUT ZINC 1/4-20
5	39-50-5005	1	HYDROLISTATIC PUMP GUARD SUPPORT
6	NC02-22-0008	6	WASHER ZINC 5/16"
7	NC02-32-0011	6	LOCK WASHER ZINC 5/16"
8	NC13-45-0142	2	90° 1/4 FEMELLE NPT X 1/4 MALE NPT
9	39-42-0090	2	RUBBER FOAM SEAL TAPE BLACK 1/4" X 3/4" X 14 1/2" LG
10	NC01-17-0058	6	HEX. BOLT GR2 ZINC 5/16-18 X 3/4"
11	39-42-0095	2	RUBBER FOAM SEAL TAPE BLACK 1/4" X 3/4" X 9 7/8" LG
12	39-01-6600	2	GAS TANK STRIP SUPPORT
13	NC13-37-0673	1	GAS CAP
14	NC13-68-0022	1	BRASS BARBED FITTING 3/16" X 1/4" NPT
15	39-46-0155	1	GAS LINE 1/4" X 38" LG
16	NC13-68-0032	1	PLASTIC BARBED TEE FITTING TEE CONNECTOR 3/16" (GASOLINE)
17	NC01-65-0305	1	CONSTANT-TENSION SPRING CLAMPS 7/16"
18	NC01-65-0304	1	CONSTANT-TENSION SPRING CLAMPS 5/16"

39-57-0190

#	PART #	Qty	TITLE
1	39-55-0700	1	ROLLER ARM
2	NC02-07-0022	2	HEX. NUT ZINC 5/8-11
3	NC02-32-0016	2	LOCK WASHER ZINC 5/8"
4	NC01-17-0398	2	HEX. BOLT GR2 NC ZINC 5/8-11 X 2 1/2"
5	39-21-0055	2	RING

39-55-0700

#	PART #	Qty	TITLE
6	NC01-67-0308	2	MAL ROD END THREAD 5/8-18
7	39-21-0060	1	ARM
8	NC02-10-0022	2	HEX. NUT ZINC 5/8-18

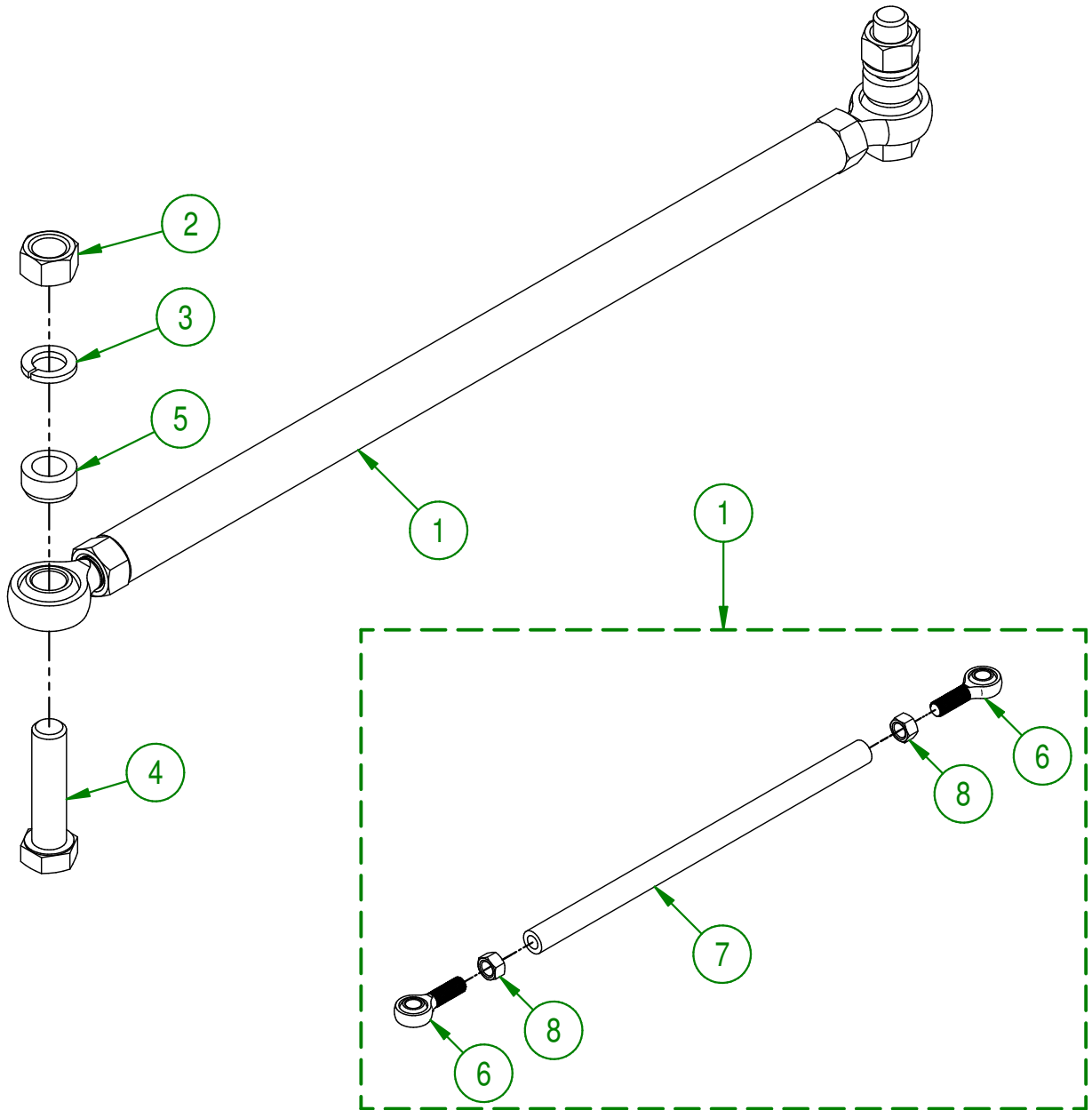

**AGRIMETAL**  
ROLLER ARM GROUP

CREATION : 25/04/18  
REVISION : 06/12/18

ASSEMBLY : **39-57-0190**  
AUTHOR : J.KABWE



#	PART #	Qty	TITLE
1	NCI3-12-0001	1	12 VOLTS BATTERY
2	39-21-0065	1	RIGHT LIGHT HOLDER
3	39-55-0121	2	LED LIGHT
4	NC01-17-0068	1	HEX. BOLT GR2 NC ZINC 5/16-18 X 3"
5	NC02-32-0011	2	LOCK WASHER ZINC 5/16"
6	NC02-07-0017	1	HEX. NUT 5/16-18
7	39-57-0195	1	BATTERY STRAPE
8	39-01-3050	1	LIGHT SWITCH HOLDER
9	NC01-04-0027	2	CARR. BOLT 1/4-20 X 6" LG
10	NC01-96-0009	2	NYLON-INSERT LOCKNUT ZINC 1/4-20
11	NCI3-25-0368	1	LIGHT SWITCH
12	39-55-0815	1	BATTERY CABLE 36" ( POSITIVE) (GR 400)
13	39-55-0820	1	BATTERY CABLE 36" (NAGATIVE) (GR 400)
14	39-57-0625	1	COMPLETE ELECTRIC WIRE SET
15	NCI3-80-0267	1	RED PROTECTOR FOR BATTERY POST
16	NCI3-80-0268	1	BLACK PROTECTOR FOR BATTERY POST
17	NCI3-25-0229	2	BLACK NYLON CABLE TIE
18	NCI3-25-0019	1	NYLON CABLE TIE
19	NCI3-25-0245	1	BLACK TIE RAP
20	NC01-17-0058	1	HEX. BOLT GR2 ZINC 5/16-18 X 3/4"
21	33-01-4000	1	HOUR METER HOLDER
22	NCI3-37-0669	1	HOUR METER

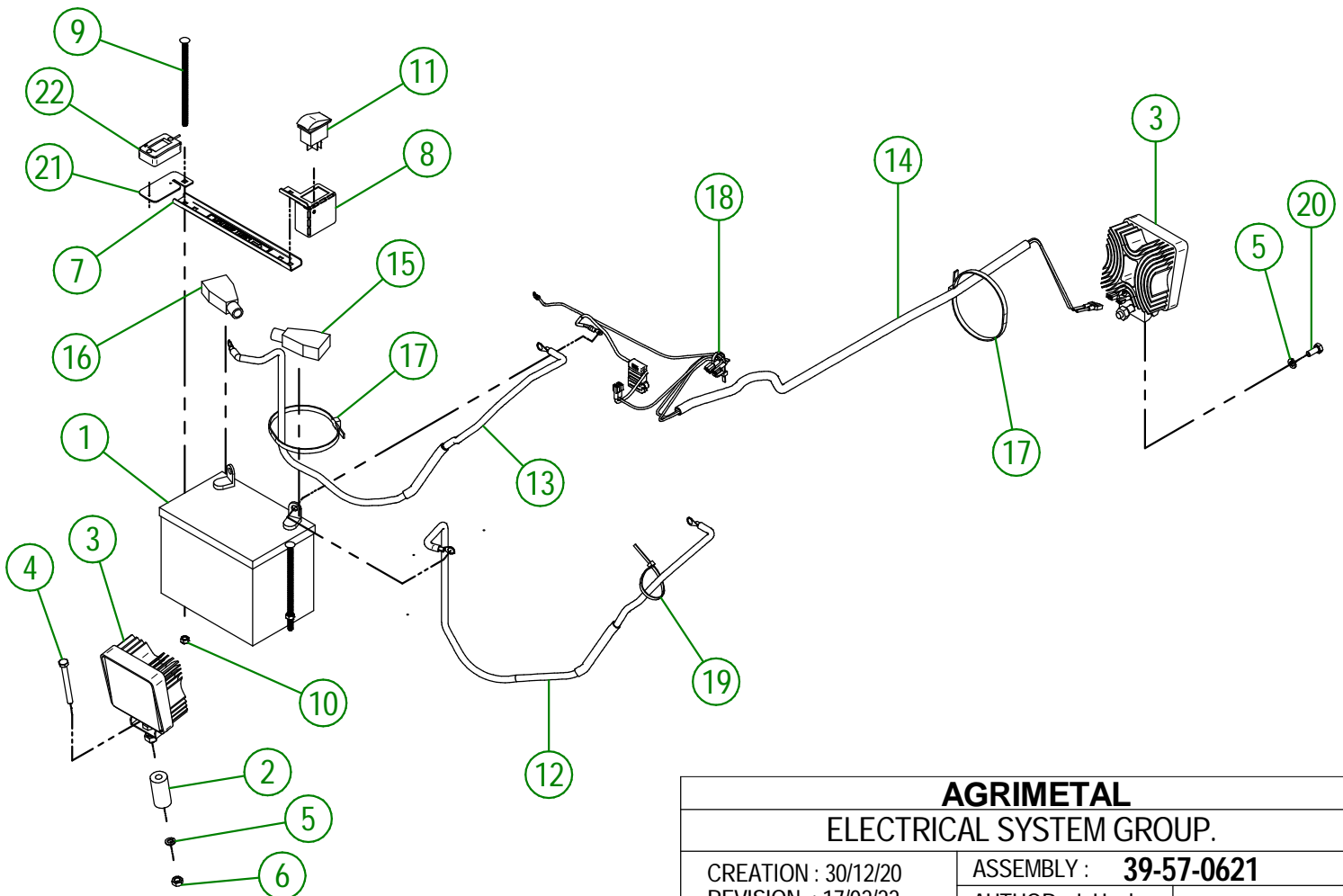

<b>AGRIMETAL</b>	
ELECTRICAL SYSTEM GROUP.	
CREATION : 30/12/20	ASSEMBLY : <b>39-57-0621</b>
REVISION : 17/02/22	AUTHOR : J. Houle

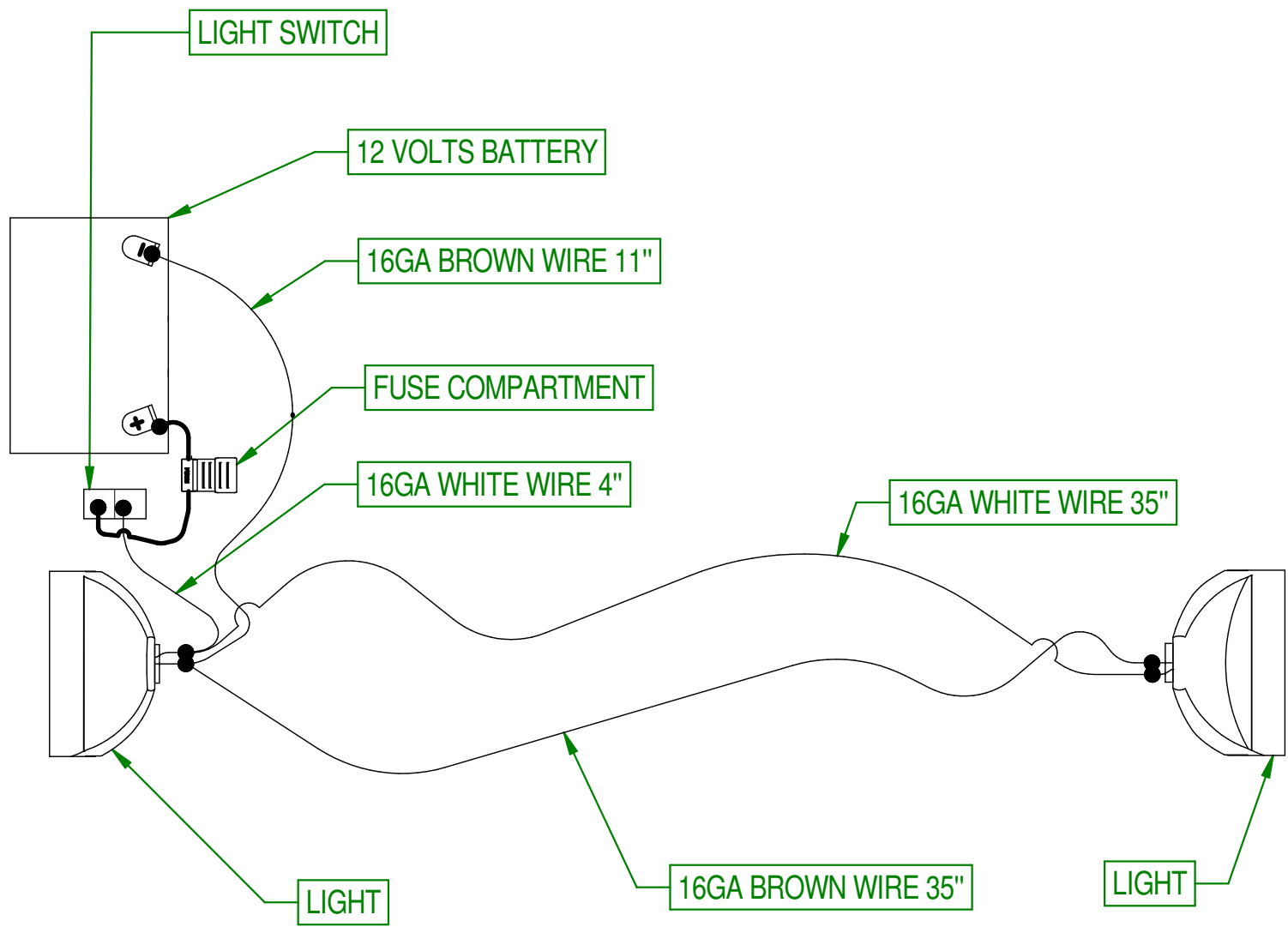

<b>AGRIMETAL</b>	
<b>COMPLETE ELECTRIC WIRE SET</b>	
CREATION : 01/05/18	ASSEMBLY : <b>39-57-0625</b>
REVISION : 02/05/18	AUTHOR : J.KABWE

#	PART #	Qty	TITLE
1	NC13-45-0032	2	STRAIGHT HOSE FITTING 1/2 FEM. NPT X 3/4 MALE NPT
2	NC13-45-0091	2	STRAIGHT HOSE FITTING 1/2 MALE NPTF X 1/2 FEM. SWIVEL
3	NC17-02-0313	1	HYDRAULIC HOSE 19"
4	NC13-25-0019	6	NYLON CABLE TIE
5	NC17-02-0374	1	HYDRAULIC HOSE 63"
6	NC17-02-0372	1	HYDRAULIC HOSE 59"
7	NC13-25-0229	3	BLACK NYLON CABLE TIE
8	NC17-02-0317	1	HYDRAULIC HOSE 64"
9	39-55-0365	1	HYDRAULIC HOSE 75"
10	NC17-02-0376	1	HYDRAULIC HOSE 36"
11	NC13-45-0048	1	OIL FILTER
12	NC13-45-0049	1	HEAD FILTER

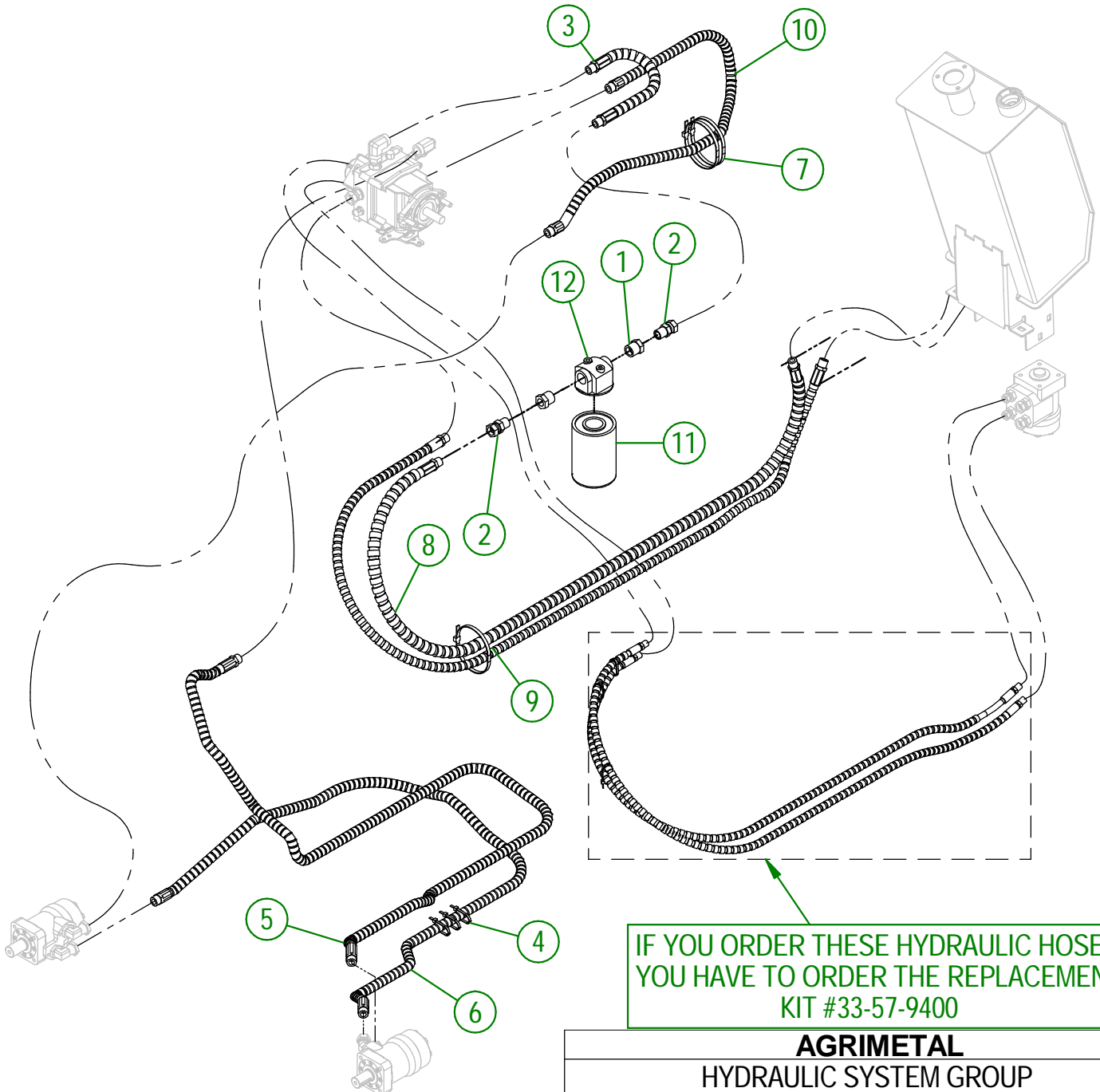

IF YOU ORDER THESE HYDRAULIC HOSE  
YOU HAVE TO ORDER THE REPLACEMENT  
KIT #33-57-9400

<b>AGRIMETAL</b>	
<b>HYDRAULIC SYSTEM GROUP</b>	
CREATION : 10/02/22	ASSEMBLY : <b>39-57-0593</b>
REVISION : 04/03/24	AUTHOR : J. Houle

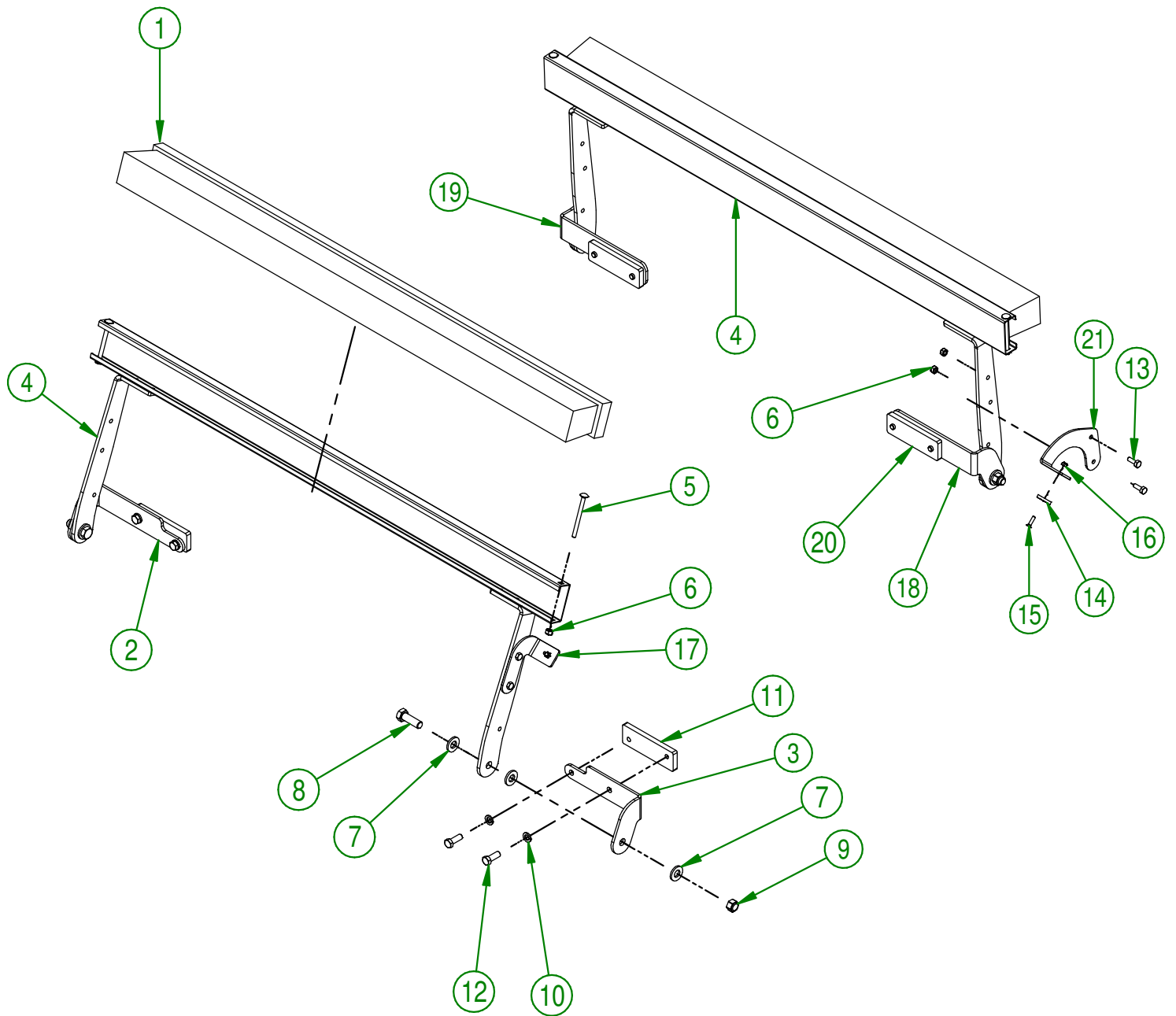

**AGRIMETAL  
BRUSHES KIT**

CREATION : 25/05/21  
REVISION : 04/11/21

ASSEMBLY : **39-57-9110**  
AUTHOR : G.HUBERDEAU

39-57-9110

#	PART #	Qty	TITLE
1	NC13-80-0294	2	BRUSH
2	39-04-0527	1	BRUSH HOLDER (FRONT-LEFT)
3	39-04-0525	1	BRUSH HOLDER (REAR-LEFT)
4	39-50-9100	2	BRUSH SUPPORT
5	NC01-02-0013	4	CARR. BOLT GR2 ZINC 1/4-20 X 3/4"
6	NC01-96-0009	8	NYLON-INSERT LOCKNUT ZINC 1/4-20
7	NC02-25-0011	12	WASHER SAE ZINC 17/32 ID
8	NC01-17-0249	4	HEX. BOLT GR2 ZINC 1/2-13 X 1 1/2"
9	NC01-96-0014	4	NYLON-INSERT LOCKNUT ZINC 1/2-13
10	NC02-32-0012	8	LOCK WASHER ZINC 3/8"
11	39-05-0510	2	PLATE FOR BRUSH HOLDER (LEFT)
12	NC01-17-0114	8	HEX. BOLT GR2 ZINC 3/8-16 X 1"
13	NC01-17-0004	4	HEX. BOLT GR2 ZINC 1/4-20 X 3/4"
14	NC13-05-0008	2	MAGNET
15	NC02-36-0110	2	MACHINE SCREW FLAT HEAD 10-24 X 3/4" LG.
16	NC01-96-0006	2	NYLON NUT ZINC 10-24
17	39-01-0300	1	MAGNET HOLDER (LEFT)
18	39-04-0540	1	BRUSH HOLDER (REAR-RIGHT)
19	39-04-0543	1	BRUSH HOLDER (FRONT-RIGHT)
20	39-05-0505	2	PLATE FOR BRUSH HOLDER
21	39-01-0305	1	MAGNET HOLDER (RIGHT)
22	39-01-0260	1	JIG FOR LEFT BRUSH HOLDER
23	39-01-0263	1	JIG FOR RIGHT BRUSH HOLDER

**AGRIMETAL**  
**BRUSHES KIT**

CREATION : 25/05/21  
REVISION : 04/11/21

ASSEMBLY : **39-57-9110**  
AUTHOR : G.HUBERDEAU

#	PART #	QTY	TITLE
1	NCI3-33-0124	2	STICKER STEERING ARROW
2	NCI3-33-0288	3	STICKER WARNING HIGH-PRESSURE LIQUID
3	NCI3-33-0247	2	STICKER DANGER
4	NCI3-33-0185	2	STICKER PICTOGRAM (FIRE + CIGARETTE)
5	NCI3-33-0035	2	STICKER AGRIMETAL
6	NCI3-33-0095	1	STICKER OFF ON START
7	NCI3-33-0151	1	STICKER (IMPORTANT TO PREVENT ENGINE FAILURE...)
8	NCI3-50-0086	1	SERIAL NUMBER PLATE
9	NCI3-33-0267	1	STICKER AGRIMETAL GREENS ROLLER 660
10	NCI3-33-0003	1	STICKER OIL LEVEL
11	NCI3-33-0183	1	STICKER CAUTION OPERATION MANUAL
12	NCI3-33-0335	2	4x4 STICKER
13	NCI3-33-0153	1	STICKER 87 DB
14	NCI3-33-0350	1	LIGHT SWITCH STICKER

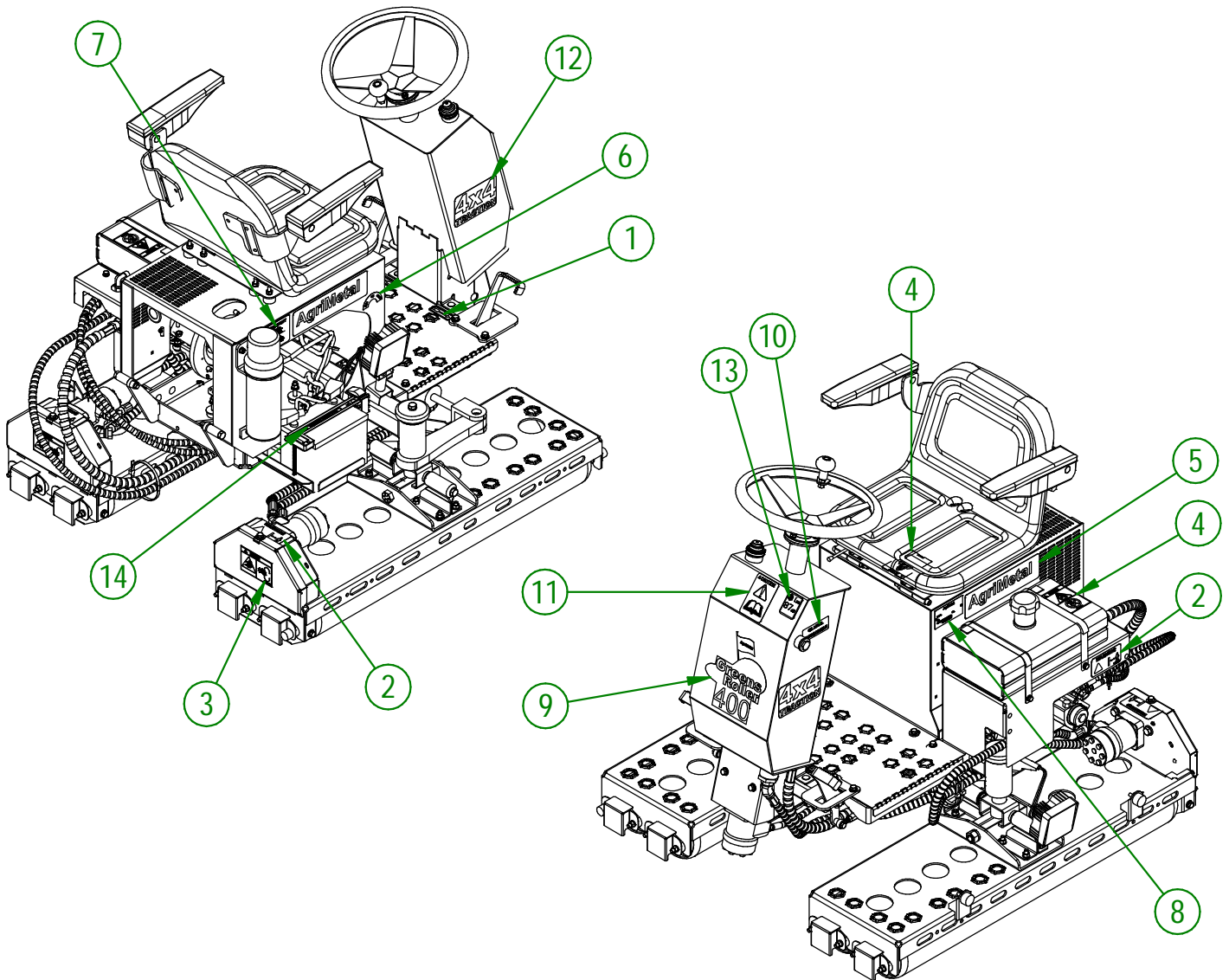

<b>AGRIMETAL</b>	
<b>GREEN ROLLER 400-F (14HP KOHLER)</b>	
CREATION : 07/09/22	ASSEMBLY : <b>39-99-0510</b>
REVISION : 08/09/22	AUTHOR : J. Houle