

AgriMetal

PART LIST

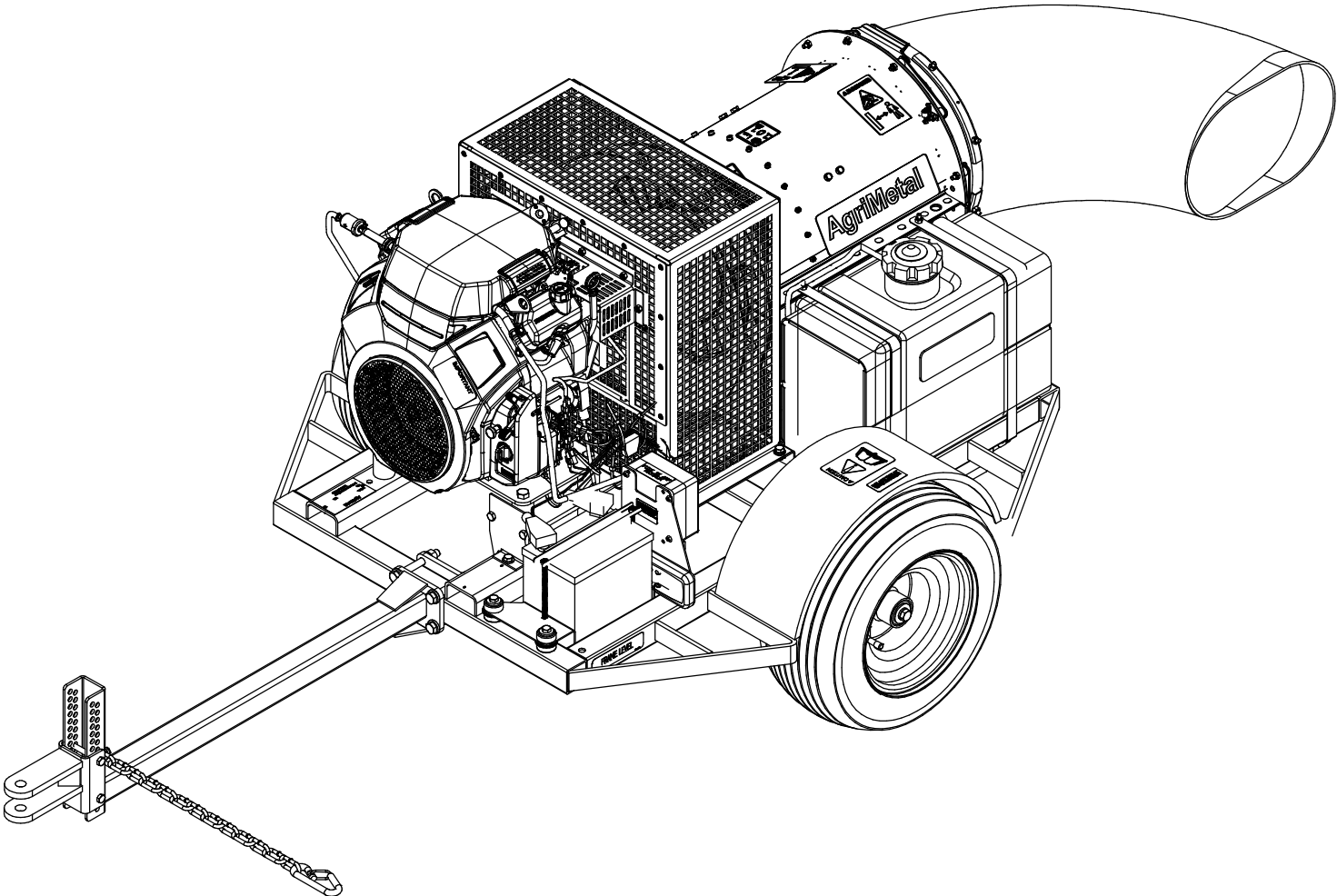

TURBINE BLOWER 240

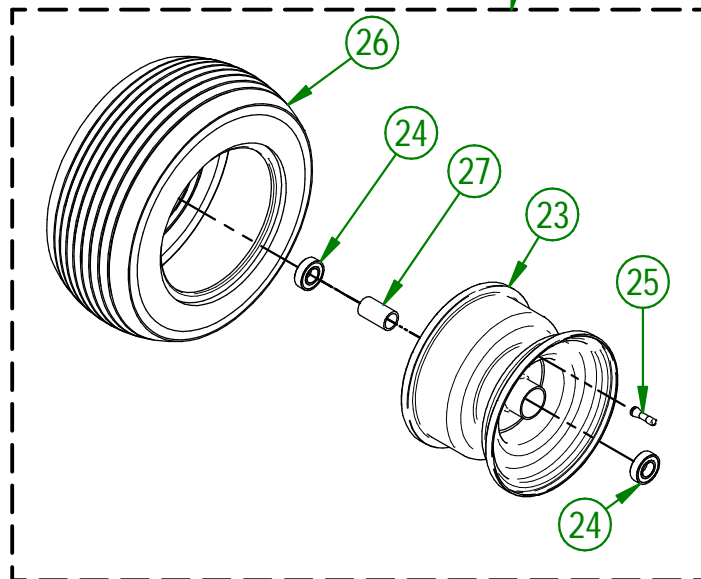
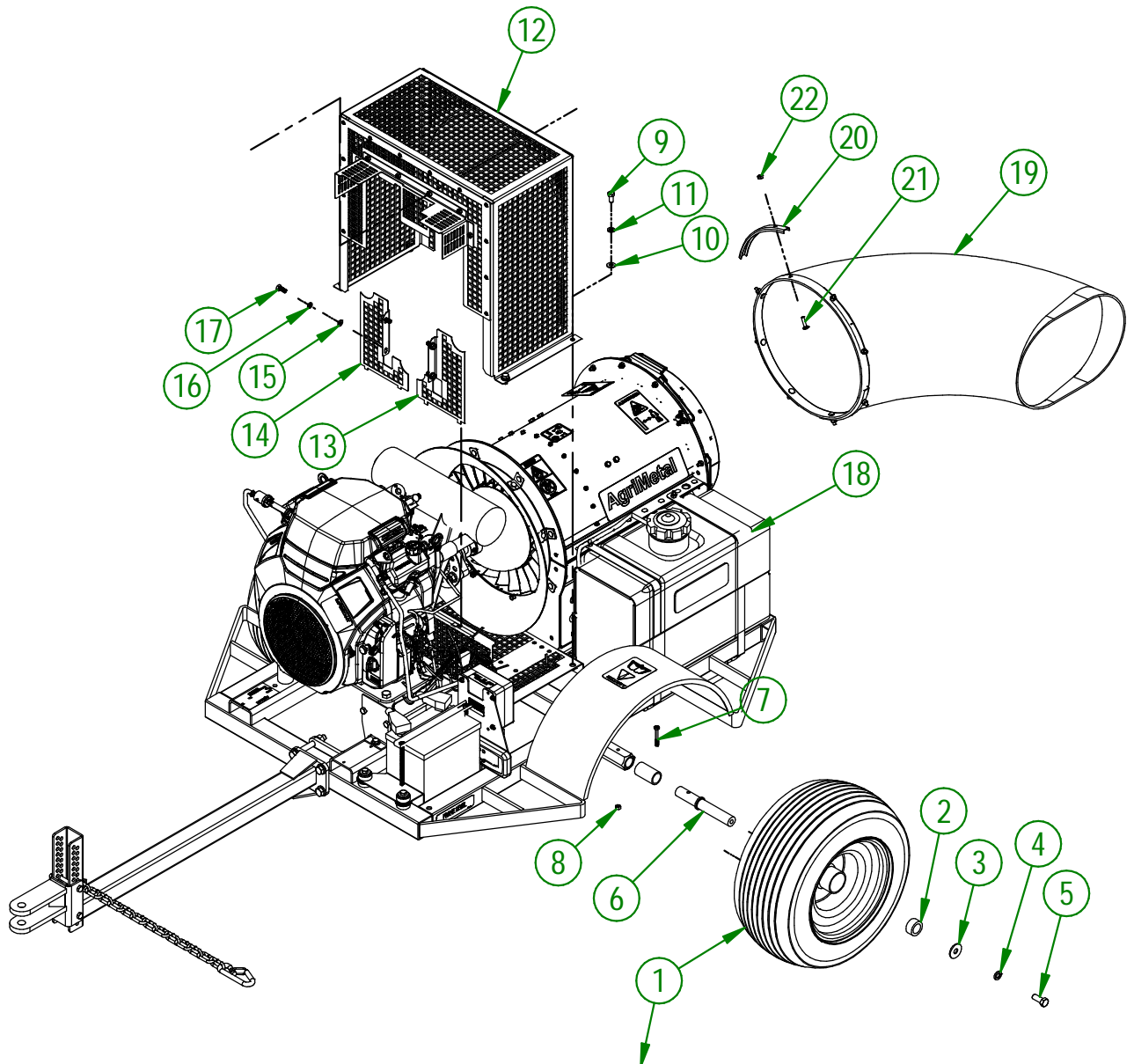

AGRIMETAL

TURBINE BLOWER 240

CREATION : 21/09/22
 REVISION : 30/10/23

ASSEMBLY : **33-99-3100**
 AUTHOR : J.KABWE

33-99-3100

#	PART #	Qty	TITLE
1	33-55-0125	2	ASSEMBLY WHEEL 18X9.50-8 WITH BALL BEARING
2	33-21-0065	2	WHEEL BUSHING
3	01-01-1660	2	WASHER SPACER
4	NC02-32-0014	2	LOCK WASHER ZINC 1/2"
5	NC01-17-0248	2	HEX. BOLT GR2 ZINC 1/2-13 X 1 1/4"
6	33-13-0100	2	AXLE SHAFT
7	NC01-33-0010	2	GRADE 8 HEX HEAD SCREW 1/4-20 X 2" LG.
8	NC01-93-0001	2	HEX. NUT NC ZINC 1/4-20
9	NC01-17-0112	4	HEX. BOLT GR2 ZINC 3/8-16 X 3/4"
10	01-01-2485	4	FLAT WASHER 14 GA X 13/16"OD X 25/64" ID
11	NC02-32-0012	4	LOCK WASHER ZINC 3/8"
12	33-55-0130	1	TURBINE GUARD (TB-240)
13	33-01-3235	1	CENTER RIGHT GRILL
14	33-01-3240	1	CENTER LEFT GRILL
15	NC02-22-0008	4	WASHER ZINC 5/16"
16	NC02-32-0011	4	LOCK WASHER ZINC 5/16"
17	NC01-29-0058	4	HEX. BOLT GR5 ZINC 5/16-24 X 3/4"
18	33-57-0132	1	GAS TANK ASSEMBLY
19	33-42-0005	1	90° PLASTIC ELBOW
20	33-01-2480	4	DUCT CLAMP
21	NC01-04-0005	8	CARR. BOLT GR2 ZINC 1/4-20 X 1"
22	NC01-96-0009	8	NYLON-INSERT LOCKNUT ZINC 1/4-20

33-55-0125

#	PART #	Qty	TITLE
23	NC14-70-0320	1	RIM FOR NC14-70-0317
24	NC14-55-0330	2	6205-2RSI BEARING
25	NC14-70-0322	1	VALVE FOR NC14-70-0317
26	NC14-70-0319	1	WHEEL 18X9.50-8 (TURBINE)
27	33-10-0015	1	INSIDE WHEEL SPACER

#	PART #	QTY	TITLE
1	NCI3-25-0369	1	ELECTRIC BOX TB 270
2	NC02-42-0096	4	PHILLIPS SCREW ZINC #14 X 5/8"
3	NCI3-15-0055	1	INSULATING ROLLED COLLAR 7/16"ID X 15/16"OD X 5/16"T
4	NCI3-25-0019	10	BLACK TIE RAP
5	33-22-2240	1	WIRE PROTECTOR
6	NCI3-25-0374	1	WIRE 46"(NEW BOX)
7	33-55-0045	1	DEFLECTOR ELECTRIC MOTOR
8	33-57-0076	1	REMOTE CONTROL GROUP.

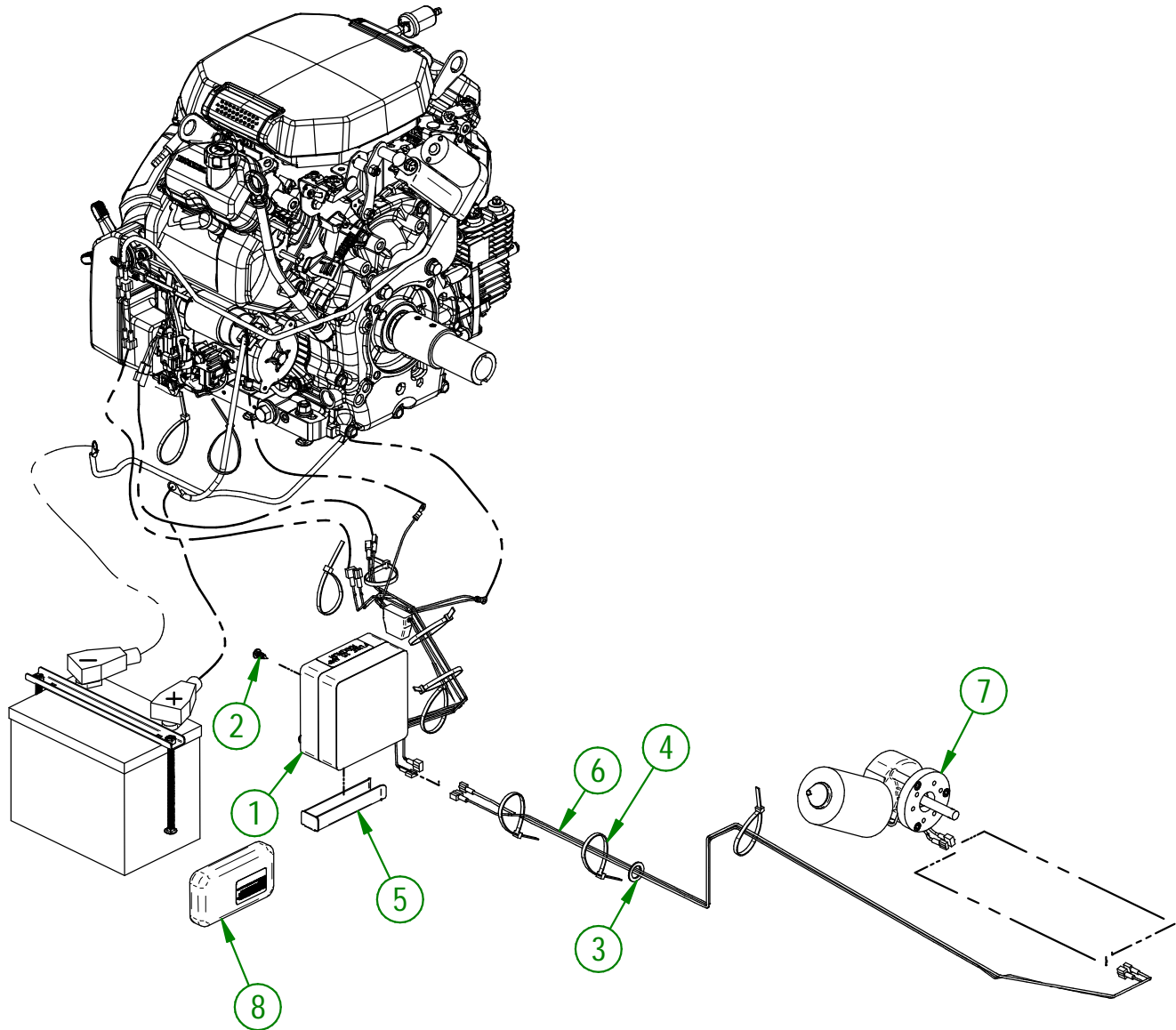

AGRIMETAL	
TURBINE BLOWER 240 CARB	
CREATION : 16/02/24	ASSEMBLY : 33-99-3100
REVISION : 16/02/24	AUTHOR : D. CHASSÉ

TB 240

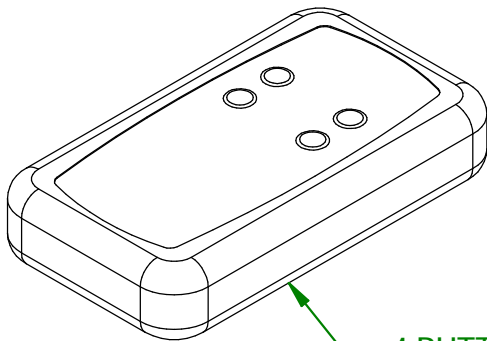
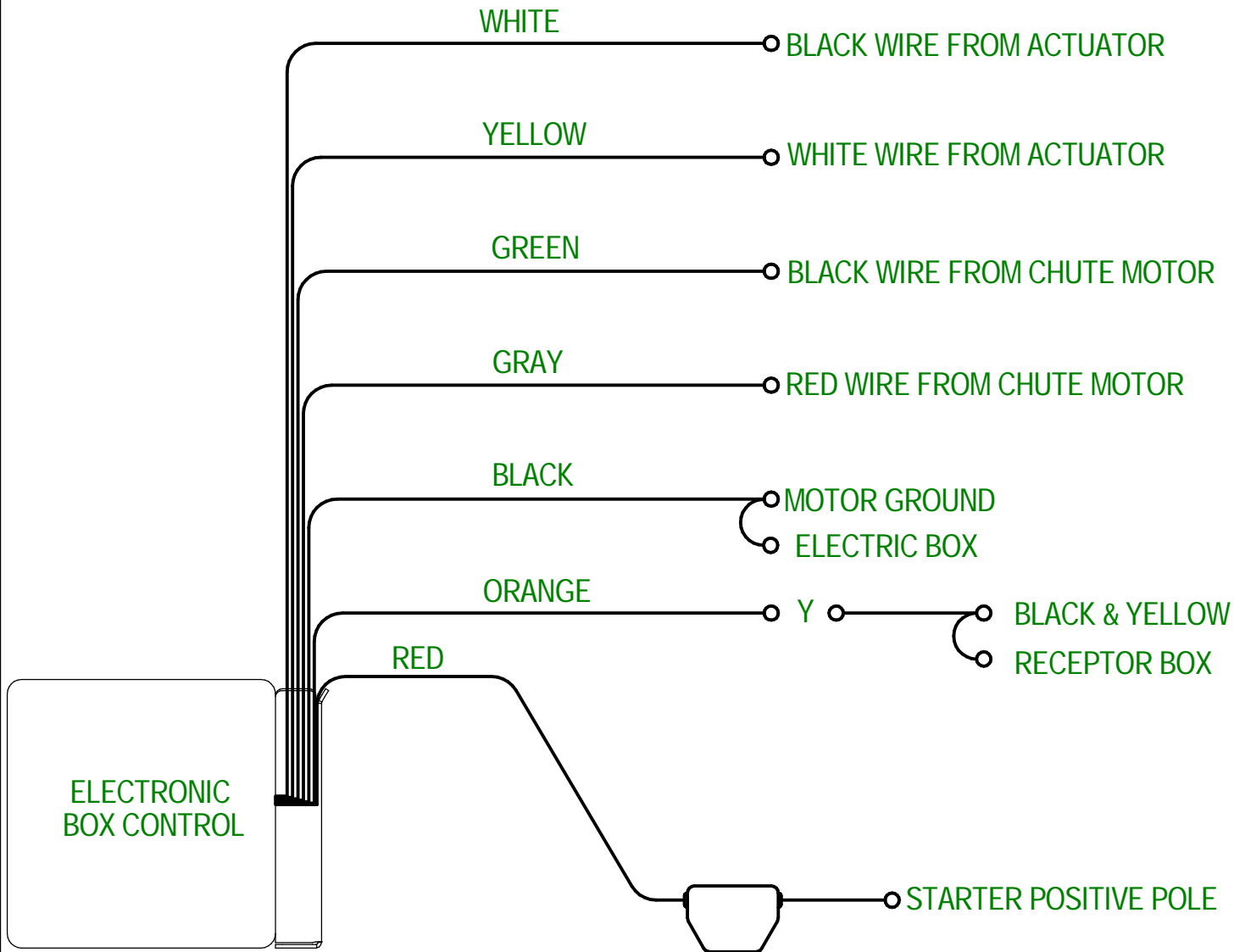

4 BUTTONS REMOTE CONTROL

AGRIMETAL	
ELECTRONIC BOX CONTROL GROUP.	
CREATION : 12/02/24	ASSEMBLY : 33-57-0006
REVISION : 16/02/24	AUTHOR : J.KABWE

33-57-0132

#	PART #	Qty	TITLE
1*	NC13-80-0248	1	GAS TANK
2	NC13-80-0266	1	1/4" ON-OFF GAS VALVE
3	NC13-80-0265	1	GROMMET VITRON #468661
4	NC13-80-0247	1	GAS CAP
5	33-01-3045	2	GAS TANK STRAP
6	33-46-0590	1	GAS VENT HOSE 1/2" DIA X 1/4" D.I. X 64"
7	NC01-04-0002	4	CARR. BOLT GR2 ZINC 1/4-20 X 5/8"
8	NC01-96-0009	4	NYLON-INSERT LOCKNUT ZINC 1/4-20
9	33-46-0660	1	GAS HOSE 1/2" DIA X 1/4" D.I. X 57"
10	NC01-65-0201	2	SPRING -GRIP HOSE CLAMPS 1/2" O.D
11	NC13-25-0019	3	BLACK TIE RAP

IF YOU ORDER A NEW TANK #1 YOU HAVE TO ORDER THE REPLACEMENT KIT # 33-57-9100

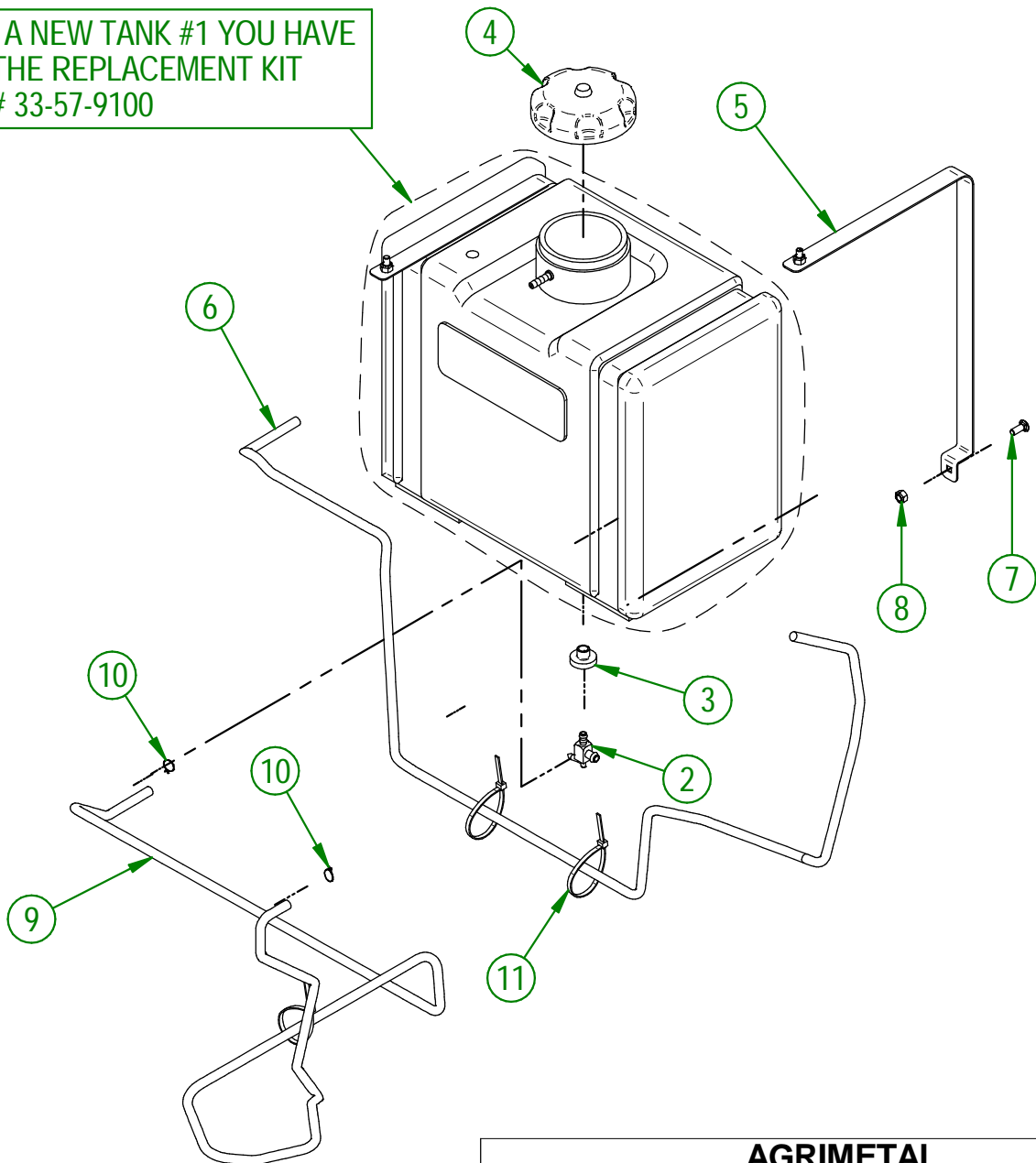

AGRIMETAL	
GAS TANK ASSEMBLY	
CREATION : 21/09/22	ASSEMBLY : 33-57-0132
REVISION : 19/06/24	AUTHOR : D. CHASSÉ

33-57-2510

#	PART #	Qty	TITLE
1	33-57-2501	1	ASSEMBLY FRAME STICKER INCLUDED
2	33-01-0085	1	HONDA BOX BRACKET
3	NC01-25-0114	1	HEX. BOLT GR2 ZINC 3/8-16 X 1"
4	NC02-25-0009	1	WASHER 0.406" I.D. X 0.815 O.D.
5	NC02-32-0012	1	LOCK WASHER ZINC 3/8"
6	NC01-93-0011	3	LOCK NUT 3/8-16
7	NC01-24-0007	2	HEX. BOLT GR5 BLACK 3/8-16 X 3/4"
8	NC01-96-0009	2	NYLON-INSERT LOCKNUT ZINC 1/4-20
9	33-57-0210	1	ENGINE BASE GROUP
10	NC01-37-0267	4	HEX. BOLT GR8 ZINC 1/2-20 X 6" LG
11	NC02-22-0012	4	WASHER ZINC 1/2 BOLT = 9/16"Ø X 1 3/8" OD
12	NC01-94-0013	4	NYLON NUT ZINC 1/2-20"
13	33-01-0330	1	SHIELD PLATE
14	NC01-07-0107	2	CARR. BOLT GR2 ZINC 3/8-16 X 3/4"
15	01-01-2485	2	FLAT WASHER 14 GA X 13/16"OD X 25/64" ID

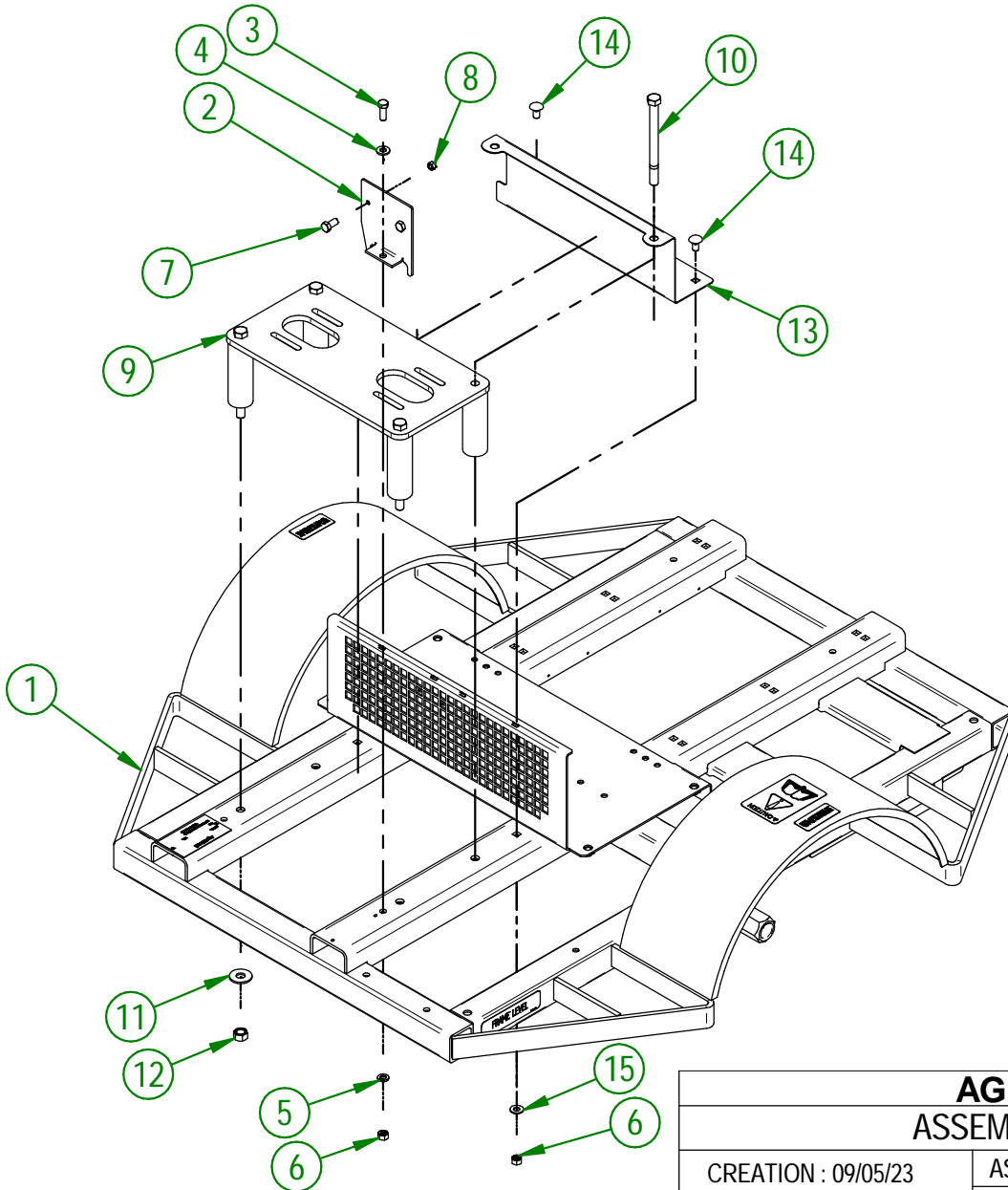

AGRIMETAL
ASSEMBLY FRAME

CREATION : 09/05/23
REVISION : 20/03/24

ASSEMBLY : **33-57-2510**
AUTHOR : D. CHASSÉ

#	PART #	Qty	TITLE
1	33-50-0010	1	DRAW BAR
2	33-50-0055	1	WELD ASSEMBLY HAND
3	33-04-0605	1	HITCH PLATE
4	NC01-17-0123	2	HEX. BOLT GR2 ZINC 3/8-16
5	NC02-32-0012	2	LOCK WASHER ZINC 3/8"
6	NC02-07-0018	2	HEX. NUT ZINC 3/8-16
7	01-01-0925	8	WASHER
8	NC02-32-0014	4	LOCK WASHER ZINC 1/2"
9	NC02-07-0020	4	HEX. NUT ZINC 1/2-13
10	NC01-17-0259	4	HEX. BOLT GR2 ZINC 1/2-13 X 4"
11	NC01-17-0116	1	HEX. BOLT GR2 ZINC 3/8-16 X 1 1/2"
12	21-01-0950	3	FLAT WASHER IOGA 1.005" DIA X 25/64"
13	55-41-0000	1	SAFETY CHAIN
14	NC01-96-0011	1	NYLON NUT 3/8-16

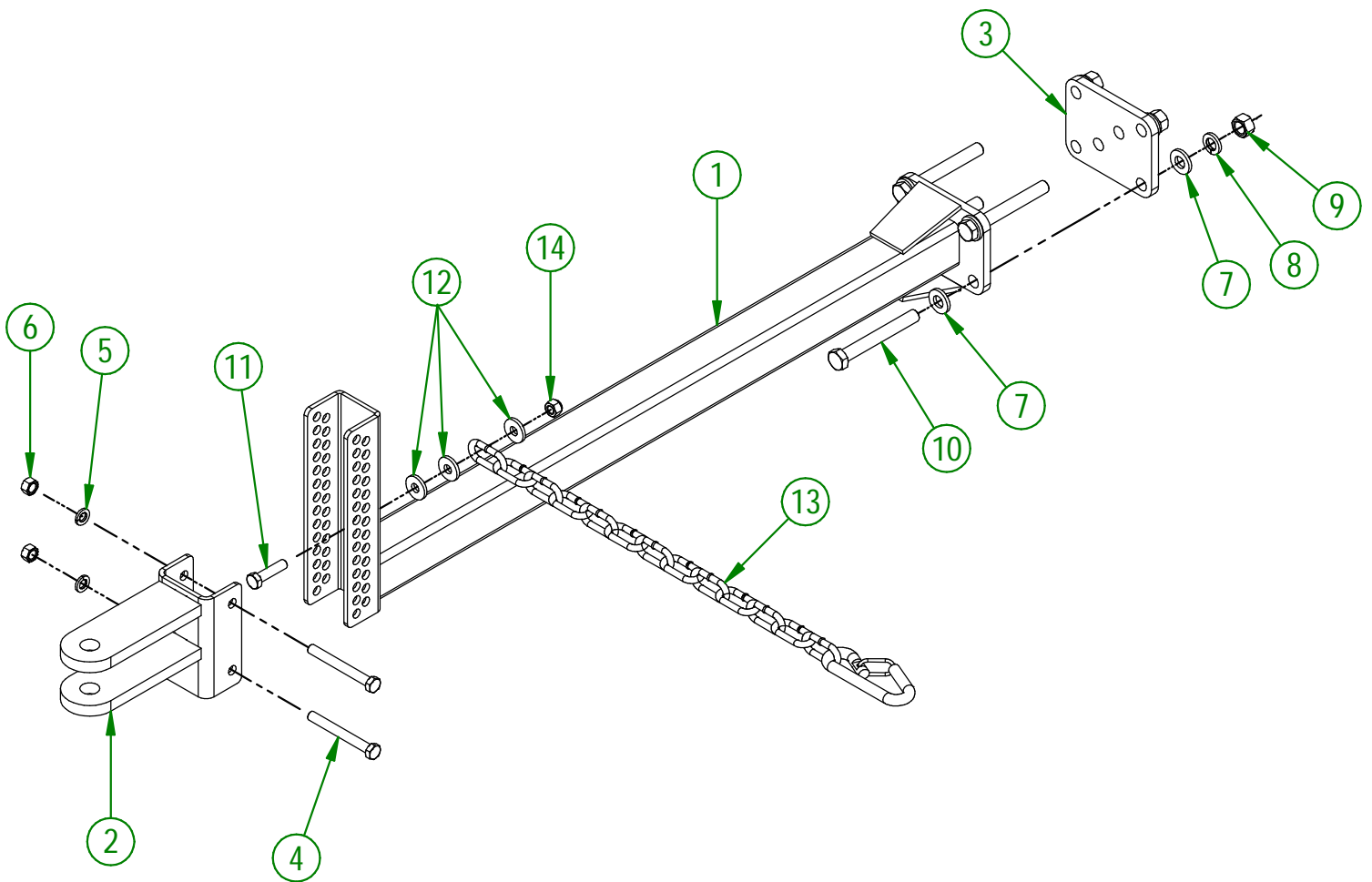

AGRIMETAL	
HITCH ASSEMBLY	
CREATION : 27/10/17	ASSEMBLY : 33-55-0040
REVISION : 24/02/22	AUTHOR : J.KABWE

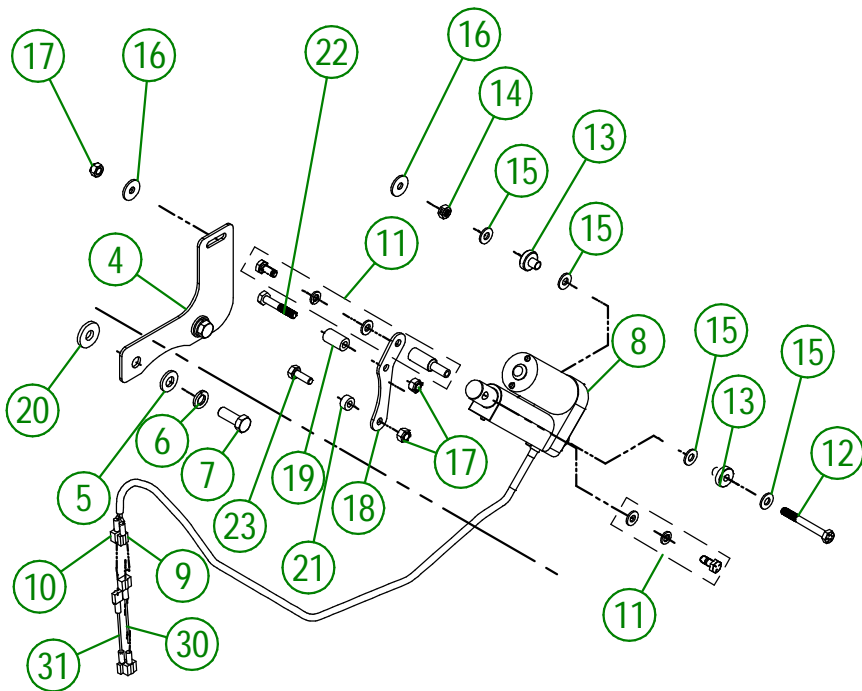

IF YOU ORDER A NEW MUFFLER
YOU HAVE TO ORDER THE
REPLACEMENT KIT #33-57-9080

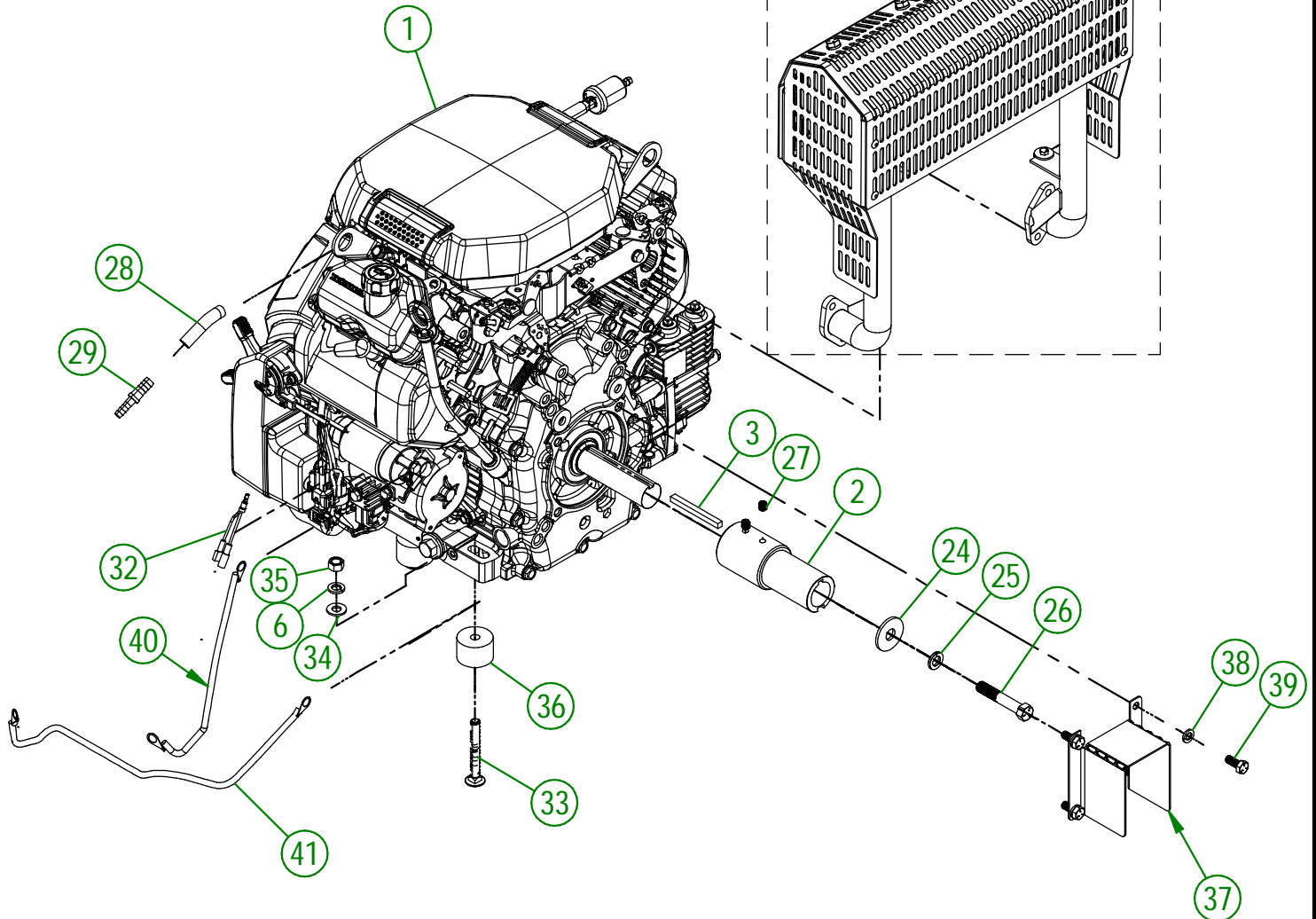
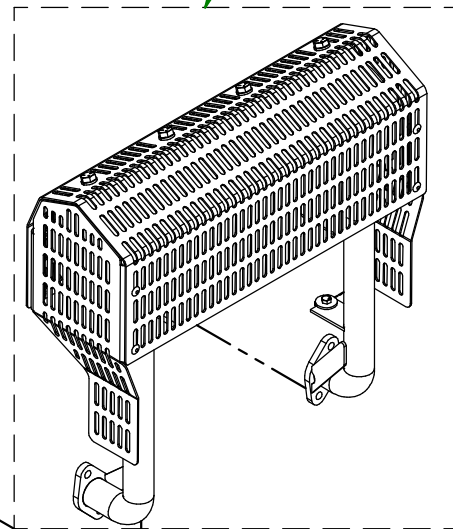

USE THESE PIECES ONLY IF YOUR SERIAL
NUMBER IS AFFECTED:

#44443 AND BELOW

AGRIMETAL	
COMPLETE HONDA ENGINE WITH PARTS	
CREATION : 20/09/22	ASSEMBLY : 33-57-2545
REVISION : 28/02/24	AUTHOR : D. CHASSÉ

33-57-2545

#	PART #	Qty	TITLE
1	33-57-0300	1	HONDA GX690 ENGINE
2	33-09-1600	1	HONDA ENGINE FITTING BUSHING
3	01-41-0925	1	SQUARE KEY 1/4" X 1/4" X 2 3/4"LG.
4	33-01-7625	1	HONDA ENGINE ACTUATOR SUPPORT
5	NC02-25-0009	2	WASHER 0.406" I.D. X 0.815 O.D.
6	NC02-32-0012	6	LOCK WASHER ZINC 3/8"
7	NC01-17-0114	2	HEX. BOLT GR2 ZINC 3/8-16 X 1"
8	NC14-35-0232	1	ELECTRIC ACTUATOR 12 VOLTS 1" TRAVEL RUN
9	NC13-25-0224	1	16 GA BLUE ISOLATED FLAT FEM. TERMINAL
10	NC13-25-0276	1	0.250" 16 GA BLUE ISOLATED FLAT MALE TERMINAL
11	33-57-0107	1	ACTION ROD
12	NC01-37-0011	1	HEX. BOLT GR8 1/4-28 X 2 1/4
13	33-42-0120	2	PIVOT BUSHING
14	NC02-14-1200	1	TWO WAY LOCK NUT 1/4-28
15	NC02-25-0007	4	WASHER ZINC 0.281 = 9/32
16	36-01-2430	2	FLAT WASHER 14GA X 17/64" I.D. X 13/16" O.D.
17	NC01-97-0004	3	NYLON-INSERT LOCKNUT ZINC 1/4-28
18	33-01-7630	1	HONDA ACTUATOR LEVER
19	33-21-0070	1	ACTUATOR SUPPORT BUSHING
20	21-01-0950	4	FLAT WASHER 10GA 1.005" DIA X 25/64"
21	33-21-0075	1	ACTUATOR SUPPORT BUSHING
22	NC01-37-0008	1	HEX. BOLT GR8 1/4-28 X 1 1/2"
23	NC01-37-0004	1	HEX. BOLT GR2 ZINC 1/4-28 X 3/4"
24	01-01-1660	1	WASHER SPACER
25	NC02-32-0013	1	LOCK WASHER ZINC 0.4375 = 7/16
26	NC01-29-0187	1	HEX. BOLT GR5 NF ZINC 7/16-20 X 2 1/2"
27	NC02-44-0103	2	SET SCREW 5/16-18 X 3/8"
28	NC13-40-0030	1	GAS LINE 3/8" I.D. X 1/2" O.D.
29	NC13-45-0389	1	BRASS BARBED HOSE FITTING 3/8" X 1/4" NPT MALE
30	33-55-0610	1	16 GA YELLOW CABLE X 2" ASSY.
31	33-55-0615	1	16 GA WHITE CABLE X 2" ASSY.
32	33-55-0650	1	16 GA BLACK CABLE (Y FOR RECEIVER) HONDA
33	NC01-02-0117	4	CARR. BOLT GR2 ZINC 3/8-16 X3"
34	01-01-2485	4	FLAT WASHER 14 GA X 13/16"OD X 25/64" ID
35	NC02-07-0018	4	HEX. NUT ZINC 3/8-16
36	33-21-0105	4	ENGINE SPACER
37	33-01-1600	1	ENGINE SHAFT GUARD
38	NC02-32-0011	4	LOCK WASHER ZINC 5/16"
39	NC01-29-0058	4	HEX. BOLT GR5 ZINC 5/16-24 X 3/4"
40	33-55-1505	1	ASSEMBLY BATTERY RED CABLE #4
41	33-55-2500	1	ASSEMBLY BATTERY BLACK CABLE #4

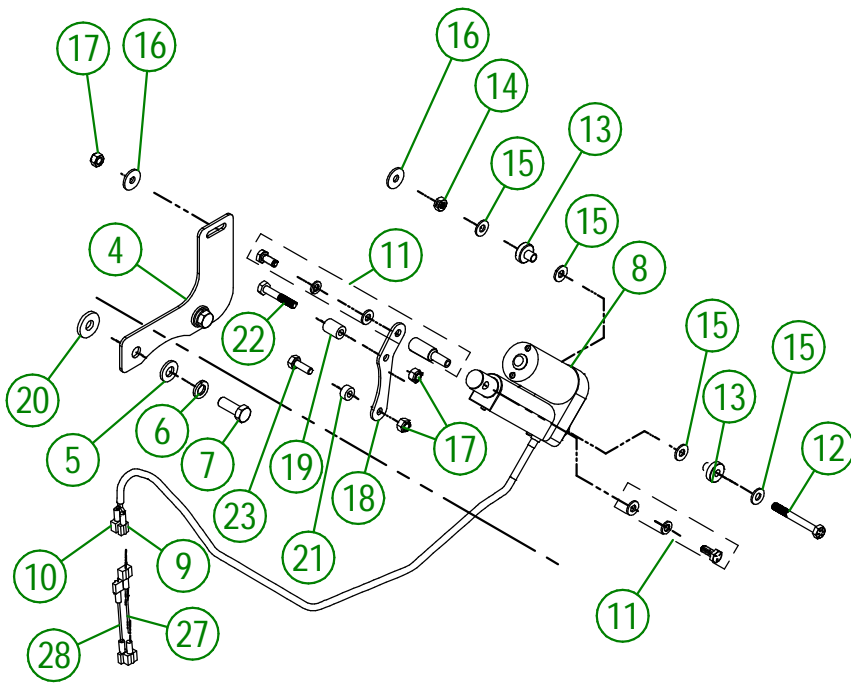

IF YOU ORDER A NEW MUFFLER
YOU HAVE TO ORDER THE
REPLACEMENT KIT #33-57-9090

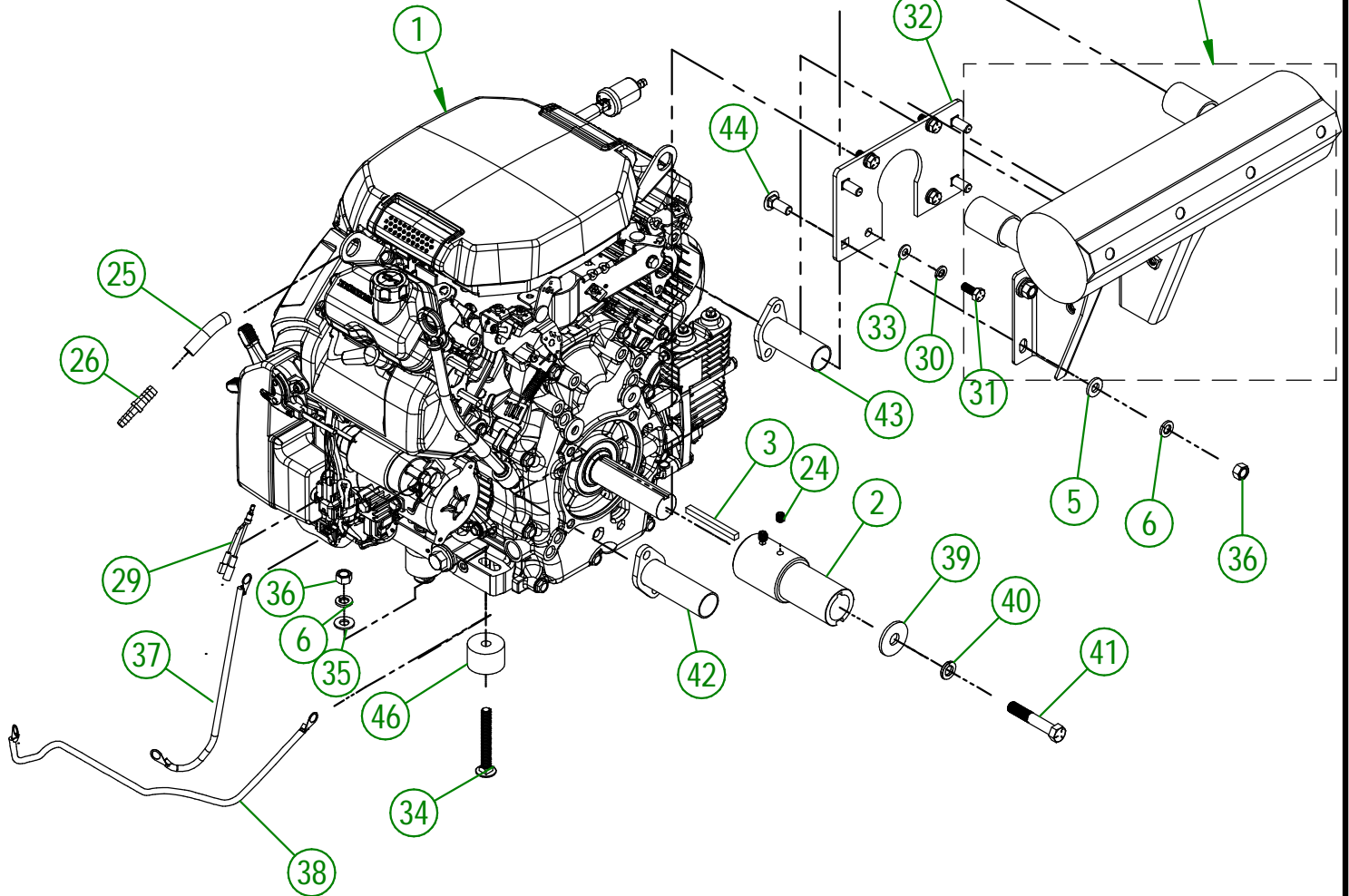

USE THESE PIECES ONLY IF YOUR SERIAL
NUMBER IS AFFECTED:

BETWEEN #44444 AND #44830

AGRIMETAL	
COMPLETE HONDA ENGINE WITH PARTS	
CREATION : 15/03/23	ASSEMBLY : 33-57-2546
REVISION : 28/02/24	AUTHOR : D. CHASSÉ

33-57-2546

#	PART #	Qty	TITLE
1	33-57-0300	1	HONDA GX690 ENGINE
2	33-09-1600	1	HONDA ENGINE FITTING BUSHING
3	01-41-0925	1	SQUARE KEY 1/4" X 1/4" X 2 3/4"LG.
4	33-01-7625	1	HONDA ENGINE ACTUATOR SUPPORT
5	NC02-25-0009	6	WASHER 0.406" I.D. X 0.815 O.D.
6	NC02-32-0012	10	LOCK WASHER ZINC 3/8"
7	NC01-17-0114	2	HEX. BOLT GR2 ZINC 3/8-16 X 1"
8	NC14-35-0232	1	ELECTRIC ACTUATOR 12 VOLTS 1" TRAVEL RUN
9	NC13-25-0224	1	16 GA BLUE ISOLATED FLAT FEM. TERMINAL
10	NC13-25-0276	1	0.250" 16 GA BLUE ISOLATED FLAT MALE TERMINAL
11	33-57-0107	1	ACTION ROD
12	NC01-37-0011	1	HEX. BOLT GR8 1/4-28 X 2 1/4
13	33-42-0120	2	PIVOT BUSHING
14	NC02-14-1200	1	TWO WAY LOCK NUT 1/4-28
15	NC02-25-0007	4	WASHER ZINC 0.281 = 9/32
16	36-01-2430	2	FLAT WASHER 14GA X 17/64" I.D. X 13/16" O.D.
17	NC01-97-0004	3	NYLON-INSERT LOCKNUT ZINC 1/4-28
18	33-01-7630	1	HONDA ACTUATOR LEVER
19	33-21-0165	1	ACTUATOR SUPPORT BUSHING
20	21-01-0950	4	FLAT WASHER 10GA 1.005" DIA X 25/64"
21	33-21-0075	1	ACTUATOR SUPPORT BUSHING
22	NC01-37-0008	1	HEX. BOLT GR8 1/4-28 X 1 1/2"
23	NC01-37-0004	1	HEX. BOLT GR2 ZINC 1/4-28 X 3/4"
24	NC02-44-0103	2	SET SCREW 5/16-18 X 3/8"
25	NC13-40-0030	1	GAS LINE 3/8" I.D. X 1/2" O.D.
26	NC13-45-0389	1	BRASS BARBED HOSE FITTING 3/8" X 1/4" NPT MALE
27	33-55-0610	1	16 GA YELLOW CABLE X 2" ASSY.
28	33-55-0615	1	16 GA WHITE CABLE X 2" ASSY.
29	33-55-0650	1	16 GA BLACK CABLE (Y FOR RECEIVER) HONDA
30	NC02-32-0011	4	LOCK WASHER ZINC 5/16"
31	NC01-29-0058	4	HEX. BOLT GR5 ZINC 5/16-24 X 3/4"
32	33-04-0250	1	MUFFLER SUPPORT PLATE
33	NC02-22-0008	4	WASHER ZINC 5/16"
34	NC01-02-0117	4	CARR. BOLT GR2 ZINC 3/8-16 X3"
35	01-01-2485	4	FLAT WASHER 14 GA X 13/16"OD X 25/64" ID
36	NC02-07-0018	8	HEX. NUT ZINC 3/8-16
37	33-55-1505	1	ASSEMBLY BATTERY RED CABLE #4
38	33-55-2500	1	ASSEMBLY BATTERY BLACK CABLE #4
39	01-01-1660	1	WASHER SPACER
40	NC02-32-0013	1	LOCK WASHER ZINC 0.4375 = 7/16
41	NC01-29-0187	1	HEX. BOLT GR5 NF ZINC 7/16-20 X 2 1/2"
42	33-50-0065	1	EXHAUST PIPE 3 1/2"
43	33-50-0070	1	EXHAUST PIPE 3"
44	NC01-07-0109	4	CARR. BOLT GR2 ZINC 3/8-16 X 1"
45	NC13-37-0134	2	HONDA ENGINE GASKET
46	33-21-0105	4	ENGINE SPACER

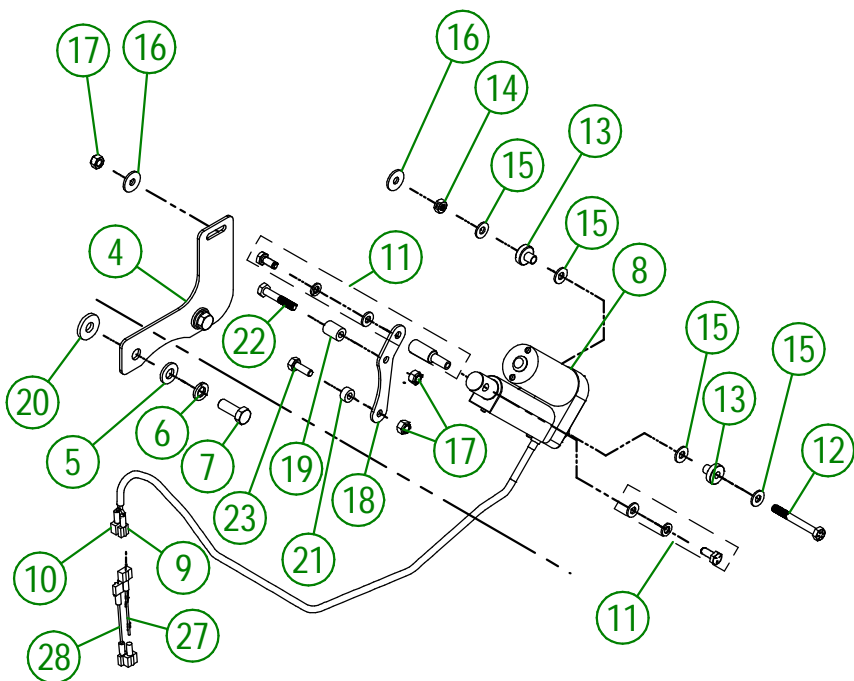

IF YOU ORDER A NEW MUFFLER
YOU HAVE TO ORDER THE
REPLACEMENT KIT #33-57-9090

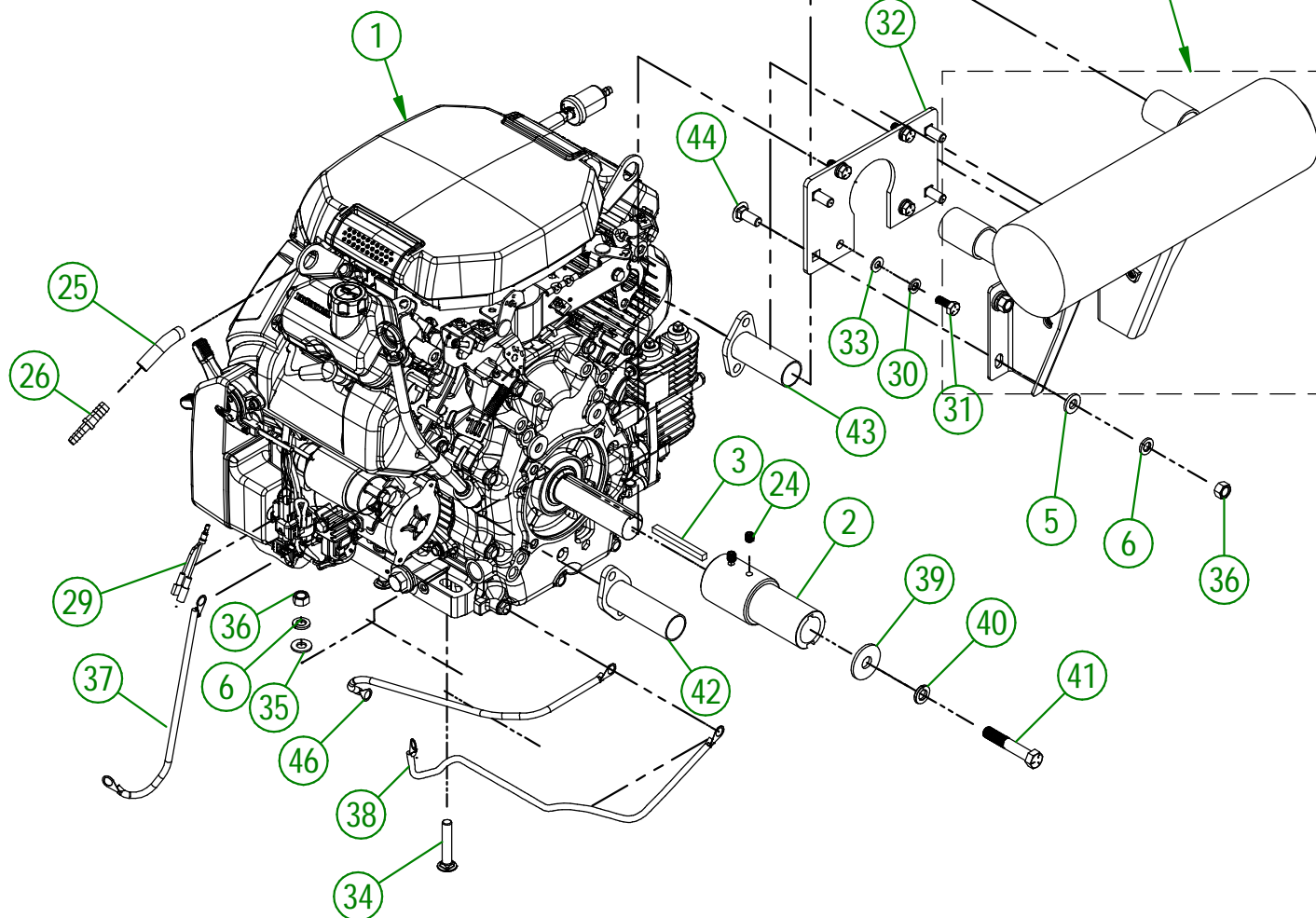

USE THESE PIECES ONLY IF YOUR SERIAL
NUMBER IS AFFECTED:

#44444 AND ABOVE

AGRIMETAL	
COMPLETE HONDA ENGINE WITH PARTS	
CREATION : 11/10/23	ASSEMBLY : 33-57-2547
REVISION : 28/02/24	AUTHOR : D. CHASSÉ

33-57-2547

#	PART #	Qty	TITLE
1	33-57-0300	1	HONDA GX690 ENGINE
2	33-09-1600	1	HONDA ENGINE FITTING BUSHING
3	01-41-0925	1	SQUARE KEY 1/4" X 1/4" X 2 3/4"LG.
4	33-01-7625	1	HONDA ENGINE ACTUATOR SUPPORT
5	NC02-25-0009	6	WASHER 0.406" I.D. X 0.815 O.D.
6	NC02-32-0012	10	LOCK WASHER ZINC 3/8"
7	NC01-17-0114	2	HEX. BOLT GR2 ZINC 3/8-16 X 1"
8	NC14-35-0232	1	ELECTRIC ACTUATOR 12 VOLTS 1" TRAVEL RUN
9	NC13-25-0224	1	16 GA BLUE ISOLATED FLAT FEM. TERMINAL
10	NC13-25-0276	1	0.250" 16 GA BLUE ISOLATED FLAT MALE TERMINAL
11	33-57-0107	1	ACTION ROD
12	NC01-37-0011	1	HEX. BOLT GR8 1/4-28 X 2 1/4
13	33-42-0120	2	PIVOT BUSHING
14	NC02-14-1200	1	TWO WAY LOCK NUT 1/4-28
15	NC02-25-0007	4	WASHER ZINC 0.281 = 9/32
16	36-01-2430	2	FLAT WASHER 14GA X 17/64" I.D. X 13/16" O.D.
17	NC01-97-0004	3	NYLON-INSERT LOCKNUT ZINC 1/4-28
18	33-01-7630	1	HONDA ACTUATOR LEVER
19	33-21-0165	1	ACTUATOR SUPPORT BUSHING
20	21-01-0950	4	FLAT WASHER 10GA 1.005" DIA X 25/64"
21	33-21-0075	1	ACTUATOR SUPPORT BUSHING
22	NC01-37-0008	1	HEX. BOLT GR8 1/4-28 X 1 1/2"
23	NC01-37-0004	1	HEX. BOLT GR2 ZINC 1/4-28 X 3/4"
24	NC02-44-0103	2	SET SCREW 5/16-18 X 3/8"
25	NC13-40-0030	1	GAS LINE 3/8" I.D. X 1/2" O.D.
26	NC13-45-0389	1	BRASS BARBED HOSE FITTING 3/8" X 1/4" NPT MALE
27	33-55-0610	1	16 GA YELLOW CABLE X 2" ASSY.
28	33-55-0615	1	16 GA WHITE CABLE X 2" ASSY.
29	33-55-0650	1	16 GA BLACK CABLE (Y FOR RECEIVER) HONDA
30	NC02-32-0011	4	LOCK WASHER ZINC 5/16"
31	NC01-29-0058	4	HEX. BOLT GR5 ZINC 5/16-24 X 3/4"
32	33-04-0250	1	MUFFLER SUPPORT PLATE
33	NC02-22-0008	4	WASHER ZINC 5/16"
34	NC01-07-0113	4	CARR. BOLT GR5 ZINC 3/8-16 X 2" LG
35	01-01-2485	4	FLAT WASHER 14 GA X 13/16"OD X 25/64" ID
36	NC02-07-0018	8	HEX. NUT ZINC 3/8-16
37	33-55-1505	1	ASSEMBLY BATTERY RED CABLE #4
38	33-55-2500	1	ASSEMBLY BATTERY BLACK CABLE #4
39	01-01-1660	1	WASHER SPACER
40	NC02-32-0013	1	LOCK WASHER ZINC 0.4375 = 7/16
41	NC01-29-0187	1	HEX. BOLT GR5 NF ZINC 7/16-20 X 2 1/2"
42	33-50-0065	1	EXHAUST PIPE 3 1/2"
43	33-50-0070	1	EXHAUST PIPE 3"
44	NC01-07-0109	4	CARR. BOLT GR2 ZINC 3/8-16 X 1"
45	NC13-37-0134	2	HONDA ENGINE GASKET
46	33-55-2505	1	ASSEMBLY BATTERY BLACK CABLE #4

#	PART #	Qty	TITLE
1	33-04-1600	2	FLANGE
2	33-21-0055	4	SLEEVE
3	01-01-0925	4	WASHER
4	33-01-7570	2	WASHER
5	NC14-62-0016	1	QD BUSHING SH I 1/4"
6	NC14-62-0233	1	QD BUSHING SH I 5/8"
7	33-20-0152	2	SPACER
8	NC01-37-0253	4	HEX. BOLT GR8 ZINC 1/2-20 X 2 1/2"
9	NC01-94-0013	4	NYLON NUT ZINC 1/2-20"
10	33-41-0920	1	SQUARE KEY

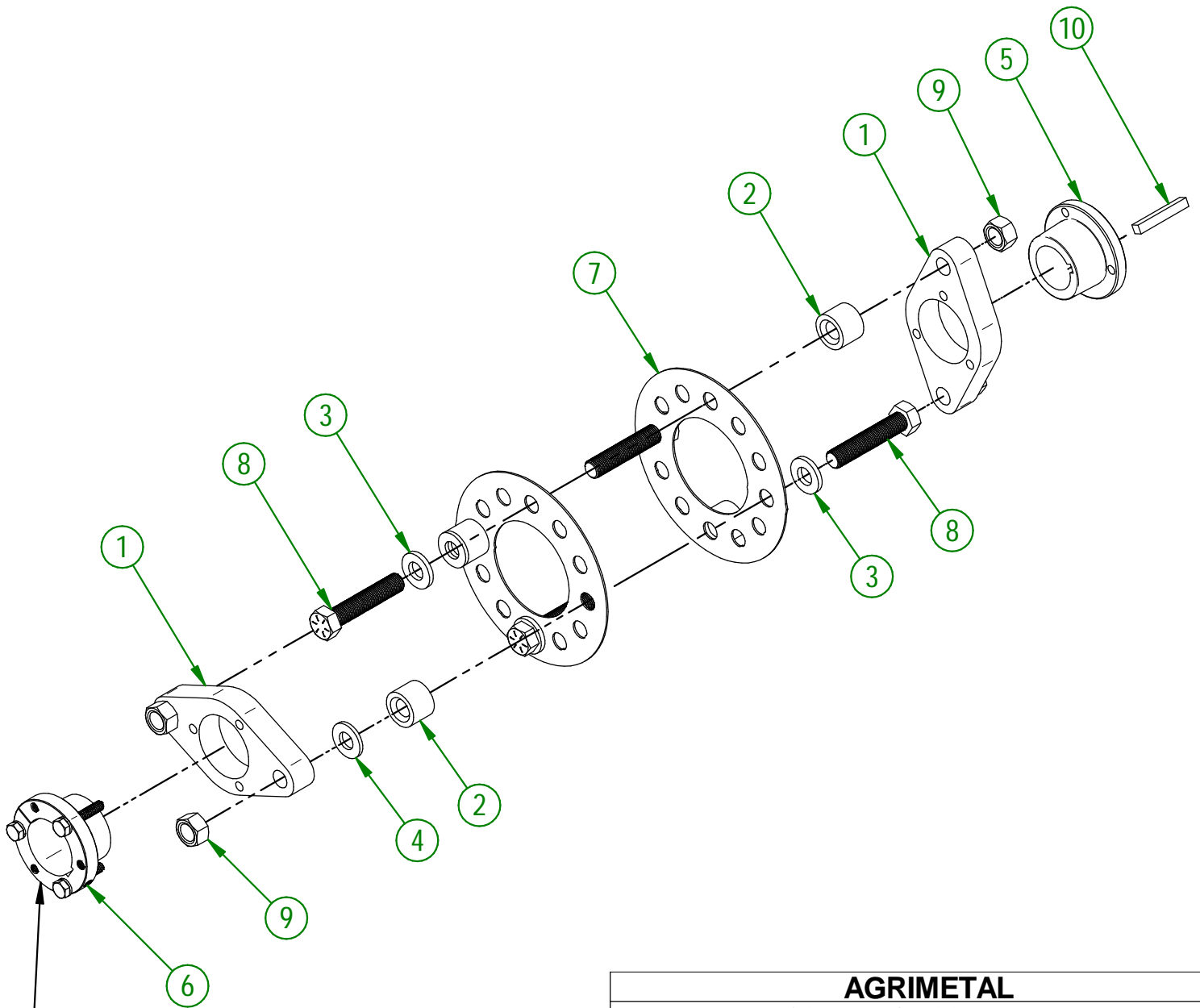

ENGINE SIDE

AGRIMETAL	
COUPLING ASSEMBLY	
CREATION : 20/09/22	ASSEMBLY : 33-57-0047
REVISION : 08/11/23	AUTHOR : D. CHASSÉ

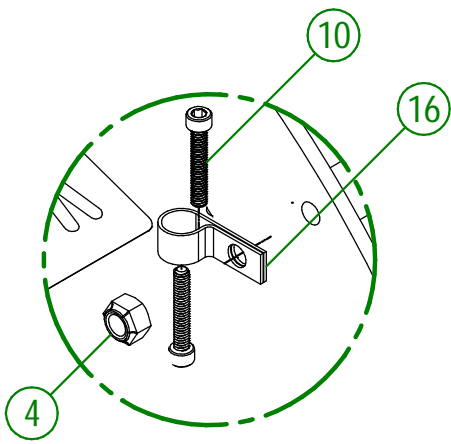
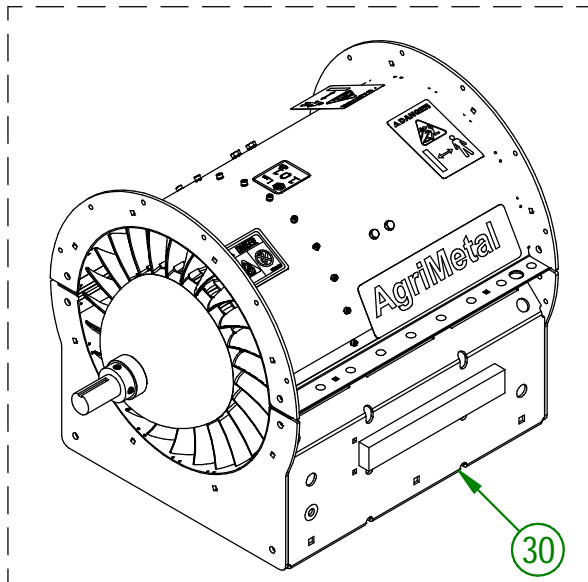

DETAIL A

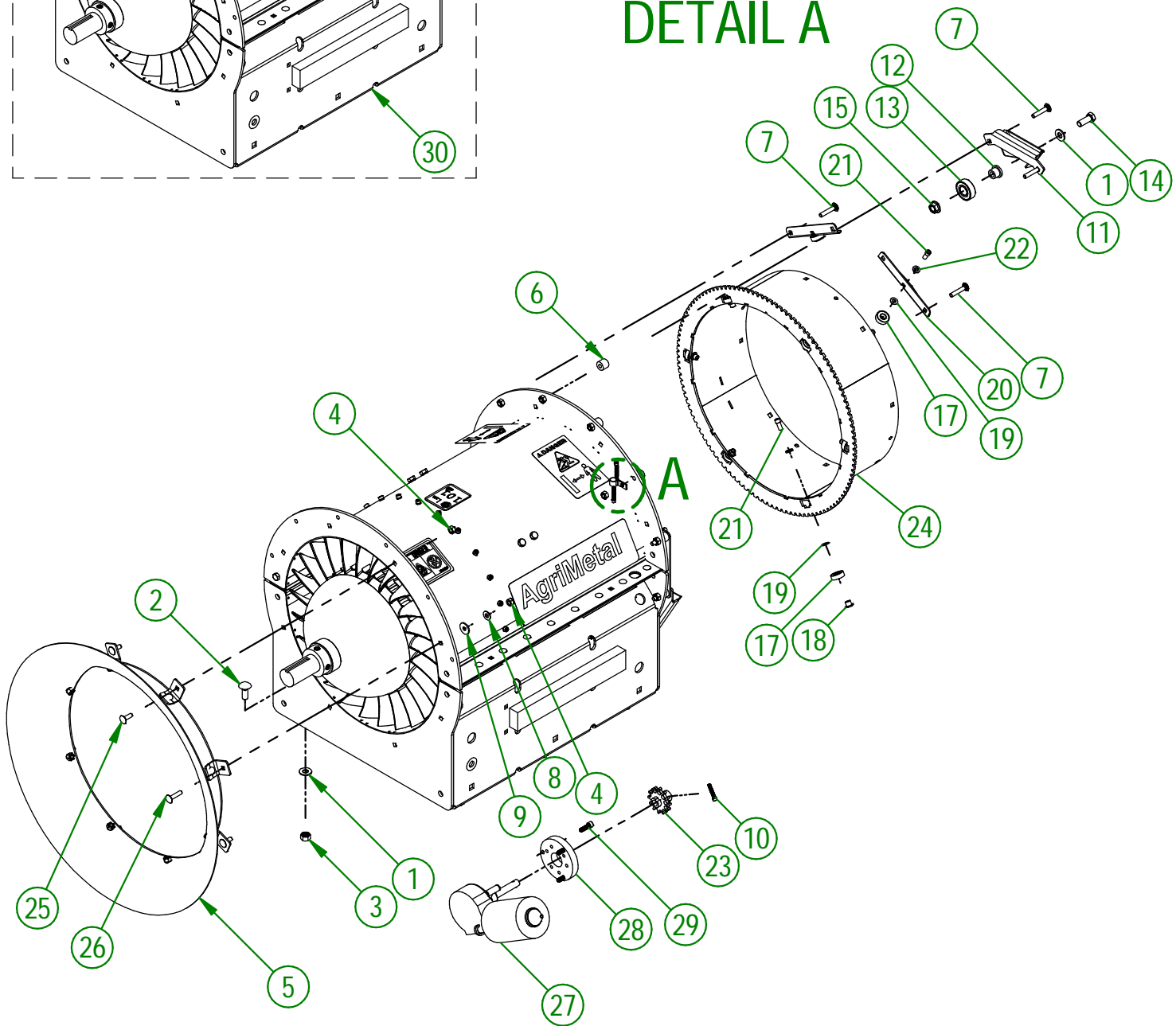

AGRIMETAL	
REGROUP. TURBINE BLOWER	
CREATION : 21/06/24	ASSEMBLY : 33-57-0080
REVISION : 21/06/24	AUTHOR : D. CHASSÉ

33-57-0080

#	PART #	QTY	TITLE
1	01-01-2485	9	FLAT WASHER 14 GA X 13/16"OD X 25/64" ID
2	NC01-04-0109	6	CARR. BOLT GR2 ZINC 3/8-16 X 1"
3	NC01-93-0011	6	LOCK NUT 3/8-16
4	NC01-96-0009	41	NYLON-INSERT LOCKNUT ZINC 1/4-20
5	33-55-0085	1	AIR INTAKE ASSY.
6	33-21-0080	12	SPACER
7	NC01-04-0006	12	CARR. BOLT GR2 ZINC 1/4-20 X 1 1/4"
8	NC02-25-0007	2	WASHER ZINC 0.281 = 9/32
9	36-01-2430	3	FLAT WASHER 14GA X 17/64" I.D. X 13/16" O.D.
10	NC02-50-0069	3	SOCKET CAP SCREW T. RON 8-32 X 1"
11	33-50-0555	3	WELD ASSEMBLY BEARING SUPPORT
12	33-21-0060	3	BEARING HOLDER
13	NC14-75-0068	3	BALL BEARING 99502H
14	NC01-17-0114	3	HEX. BOLT GR2 ZINC 3/8-16 X 1"
15	NC02-14-0019	3	FLANGE NUT HEX. NC 3/8-16 GR. B
16	NC13-25-0233	1	VINYLE PROTECTOR COLLAR
17	NC14-75-0153	12	BALL BEARING R6 2RS 3/8" X 7/8" X 0.281"
18	33-25-2410	12	BEARING BUSHING
19	33-03-4605	12	BEARING SHIM 1/4" ALUMINUM
20	33-01-2425	6	BEARING HOLDER BRACKET
21	NC02-51-0578	12	SOCKET CAP SCREW T. RON. NF 1/4-28 X 1/2 STAINLESS
22	NC02-32-0010	12	LOCK WASHER ZINC 1/4"
23	33-55-0035	1	GEARED CROWN SPROCKET
24	33-50-0018	1	DUCT COLECTOR
25	NC01-04-0003	6	CARR. BOLT GR2 ZINC 1/4-20 X 3/4"
26	NC01-04-0005	2	CARR. BOLT GR2 ZINC 1/4-20 X 1"
27	33-35-0005	1	OUTLET MOTOR
28	33-21-0100	1	ENGINE CONVERSION PLATE
29	NC02-50-1072	3	SOCKET CAP SCREW M6 X 20mm
30	33-57-0020	1	REGROUP. ENSEMBLE DE TURBINE (NEUF)

#	PART #	Qty	TITLE
1	NC01-96-0009	2	NYLON-INSERT LOCKNUT ZINC 1/4-20
2	NC01-04-0027	2	CARR. BOLT 1/4-20 X 6" LG
3	NC01-04-0056	2	CARR. BOLT 5/16-18 X 3/4"
4	33-01-3015	1	BATTERY STRAPE
5	NC02-32-0011	2	LOCK WASHER ZINC 5/16"
6	NCI3-12-0001	1	12 VOLTS BATTERY
7	NC02-07-0017	2	HEX. NUT 5/16-18
8	NCI3-80-0267	1	RED PROTECTOR FOR BATTERY POST
9	NCI3-80-0268	1	BLACK PROTECTOR FOR BATTERY POST

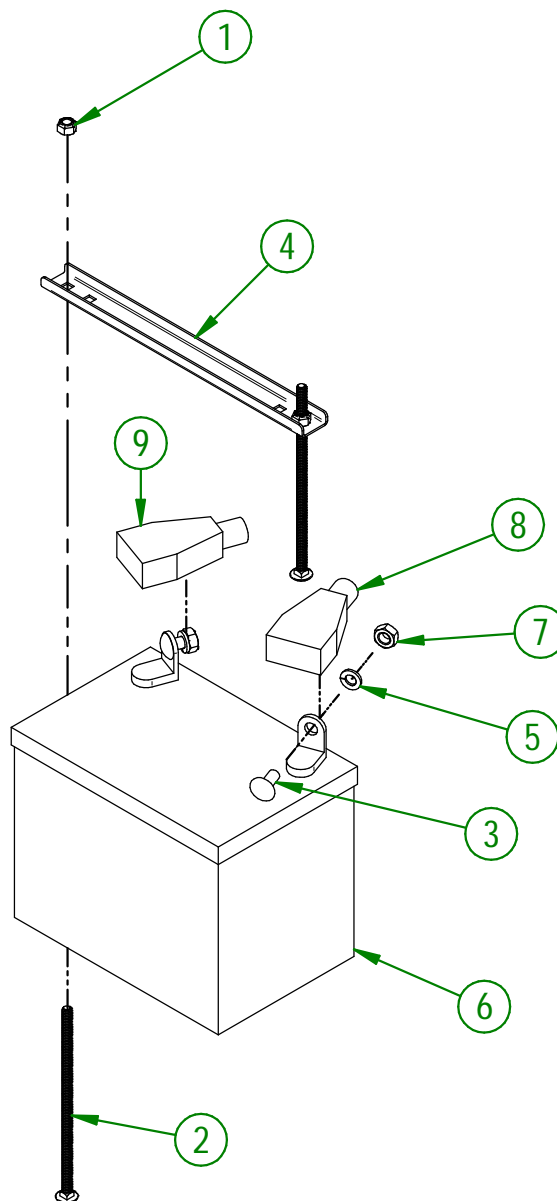

USE THESE PIECES ONLY IF YOUR SERIAL
NUMBER IS AFFECTED:

BELOW # 44661

AGRIMETAL	
12 VOLTS BATTERY GROUP.	
CREATION : 30/08/23	ASSEMBLY : 33-57-0056
REVISION : 11/09/23	AUTHOR : J.KABWE

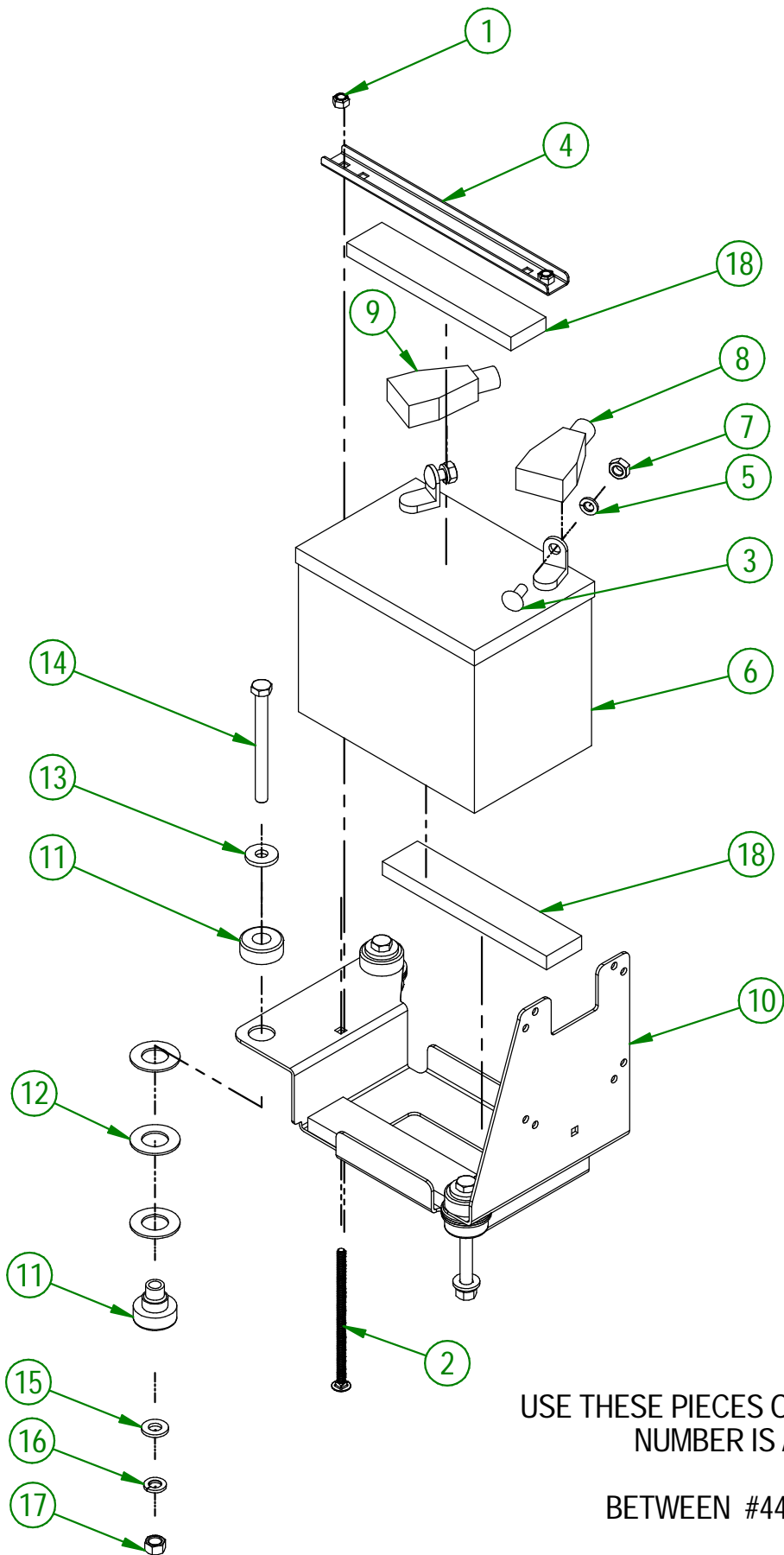

USE THESE PIECES ONLY IF YOUR SERIAL NUMBER IS AFFECTED:

BETWEEN #44661 & #45502

AGRIMETAL	
12 VOLTS BATTERY GROUP.	
CREATION : 29/08/23	ASSEMBLY : 33-57-0058
REVISION : 05/07/24	AUTHOR : D. CHASSÉ

33-57-0058

#	PART #	Qty	TITLE
1	NC01-96-0009	2	NYLON-INSERT LOCKNUT ZINC 1/4-20
2	NC01-04-0024	2	CARR. BOLT GR2 ZINC 1/4-20 X 5"
3	NC01-04-0056	2	CARR. BOLT 5/16-18 X3/4"
4	33-01-3015	1	BATTERY STRAPE
5	NC02-32-0011	2	LOCK WASHER ZINC 5/16"
6	NC13-12-0017	1	12 VOLTS GEL BATTERY
7	NC02-07-0017	2	HEX. NUT 5/16-18
8	NC13-80-0267	1	RED PROTECTOR FOR BATTERY POST
9	NC13-80-0268	1	BLACK PROTECTOR FOR BATTERY POST
10	33-57-2400	1	BATTERY SUPPORT PLATE "INCL. STICKER"
11	NC13-15-0354	3	RED RUBBER BASE MOUNT
12	26-03-4800	9	WASHER
13	21-01-0950	3	FLAT WASHER 10GA 1.005" DIA X 25/64"
14	NC01-25-0126	3	HEX. BOLT GR5 ZINC 3/8-16 X 4"
15	NC02-25-0009	3	WASHER 0.406" I.D. X 0.815 O.D.
16	NC02-32-0012	3	LOCK WASHER ZINC 3/8"
17	NC02-07-0018	3	HEX. NUT ZINC 3/8-16
18	33-42-0130	3	BLACK ADHESIVE-BACK STRIP

#	PART #	Qty	TITLE
1	NC01-04-0056	2	CARR. BOLT 5/16-18 X3/4"
2	NC02-32-0011	2	LOCK WASHER ZINC 5/16"
3	NCI3-12-0017	1	12 VOLTS GEL BATTERY
4	NC02-07-0017	2	HEX. NUT 5/16-18
5	NCI3-80-0267	1	RED PROTECTOR FOR BATTERY POST
6	NCI3-80-0268	1	BLACK PROTECTOR FOR BATTERY POST
7	33-57-2401	1	BATTERY SUPPORT PLATE "INCL. STICKER"
8	NCI3-15-0354	3	RED RUBBER BASE MOUNT
9	26-03-4800	9	WASHER
10	21-01-0950	3	FLAT WASHER 10GA 1.005" DIA X 25/64"
11	NC01-25-0126	3	HEX. BOLT GR5 ZINC 3/8-16 X 4"
12	NC02-25-0009	3	WASHER 0.406" I.D. X 0.815 O.D.
13	NC02-32-0012	3	LOCK WASHER ZINC 3/8"
14	NC02-07-0018	3	HEX. NUT ZINC 3/8-16
15	33-42-0130	2	BLACK ADHESIVE-BACK STRIP
16	NCI3-15-0008	1	RUBBER STRAP
17	33-42-0135	2	BLACK ADHESIVE-BACK STRIP

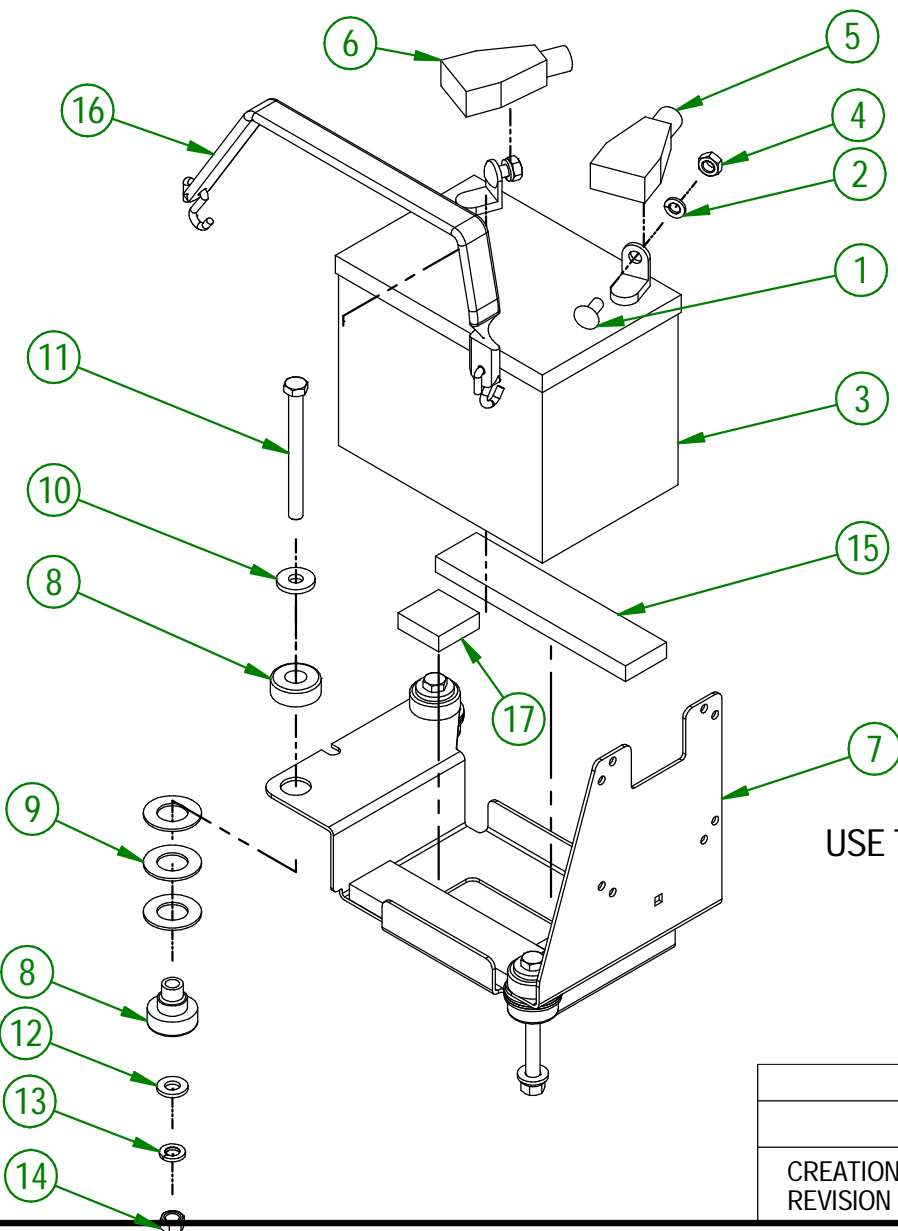

USE THESE PIECES ONLY IF YOUR SERIAL NUMBER IS AFFECTED:

#45503 AND ABOVE

AGRIMETAL	
12 VOLTS BATTERY GROUP.	
CREATION : 21/02/24	ASSEMBLY : 33-57-0059
REVISION : 05/07/24	AUTHOR : D. CHASSÉ

#	PART #	Qty	TITLE
1	NC13-30-0237	1	PLASTIC TUBE FOR OPERATOR'S MANUAL
2	NC01-04-0003	3	CARR. BOLT GR2 ZINC 1/4-20 X 3/4"
3	NC02-25-0007	3	WASHER ZINC 0.281 = 9/32
4	NC01-96-0009	3	NYLON-INSERT LOCKNUT ZINC 1/4-20
5	33-98-0621	1	OPERATION MANUAL TB 270

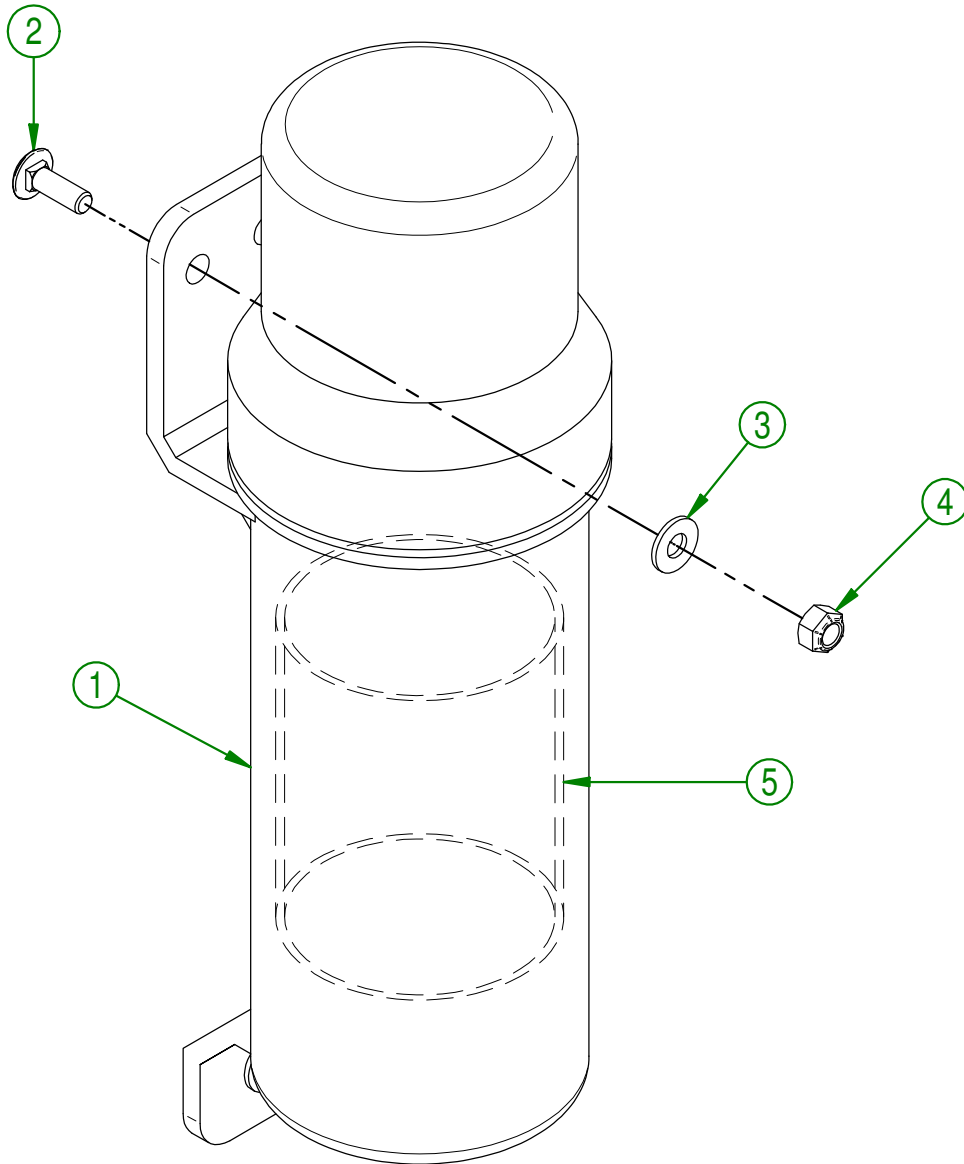

AGRIMETAL	
OPERATOR MANUEL TUBE ASSEMBLY	
CREATION : 14/02/18	ASSEMBLY : 33-57-2566
REVISION : 05/10/18	AUTHOR : J.KABWE Page 17 de 18

#	PART #	Qty	TITLE
1	NCI3-33-0052	2	STICKER FRAME LEVEL
2	NCI3-33-0183	1	STICKER CAUTION OPERATION MANUAL
3	NCI3-33-2675	2	STICKER TO INFLATE TIRE
4	NCI3-33-0227	1	STICKER FUSE 15 AMP MAXIMUM
5	NCI3-33-0192	2	STICKER (PROJECTION RISK)
6	NCI3-33-0185	1	STICKER PICTOGRAM (FIRE + CIGARETTE)
7	NCI3-33-0035	2	STICKER AGRIMETAL
8	NCI3-33-0129	1	STICKER 101 DB
9	NCI3-33-2674	2	STICKER TO PROGRAM REMOTE CONTROL
10	NCI3-33-0178	1	STICKER IMPORTANT PLEASE CHECK OIL LEVEL...

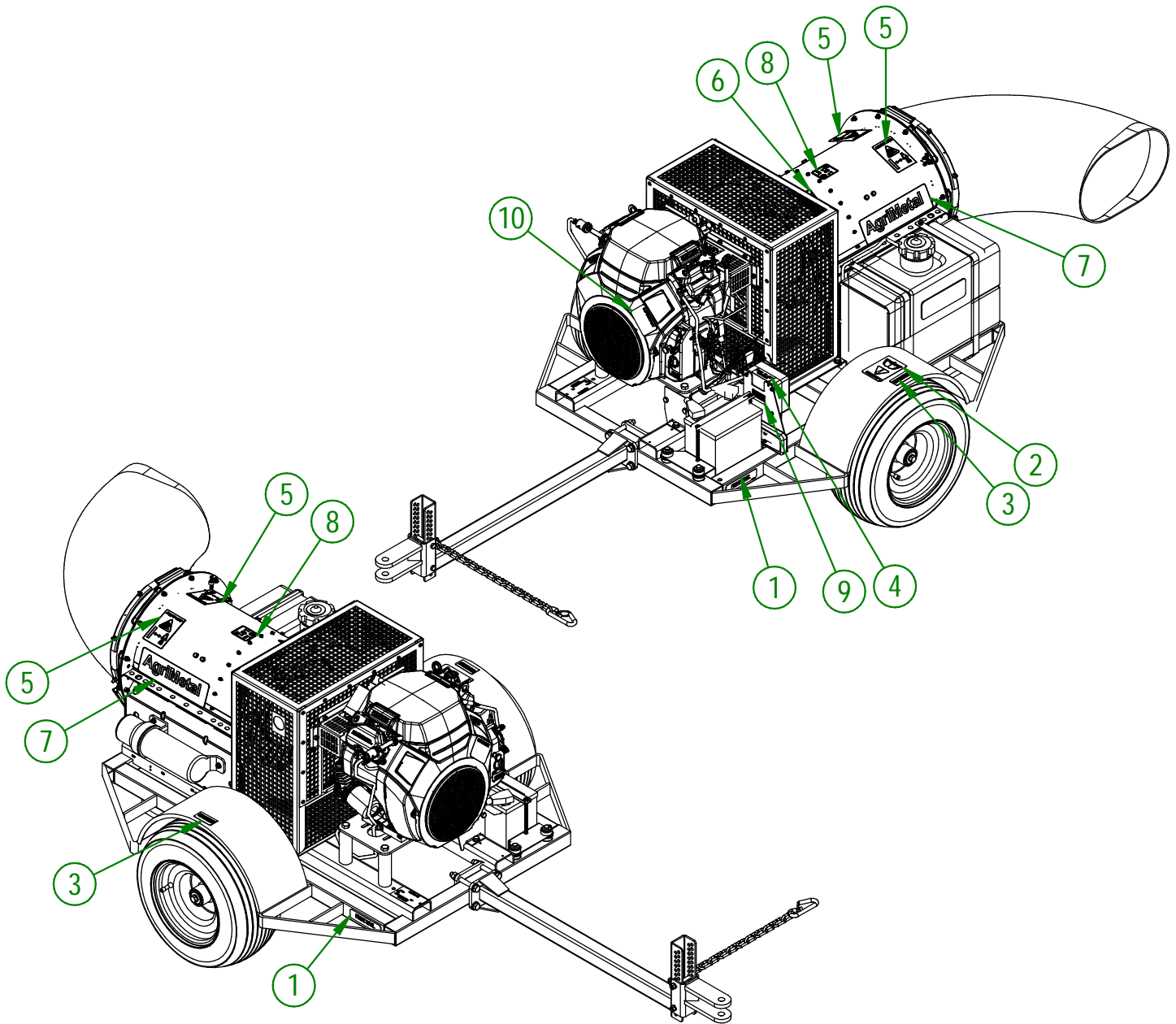

AGRIMETAL
TURBINE BLOWER 240

CREATION : 21/09/22
REVISION : 30/10/23

ASSEMBLY : **33-99-3100**
AUTHOR : D. CHASSÉ