

# AgriMetal

## PARTS LIST

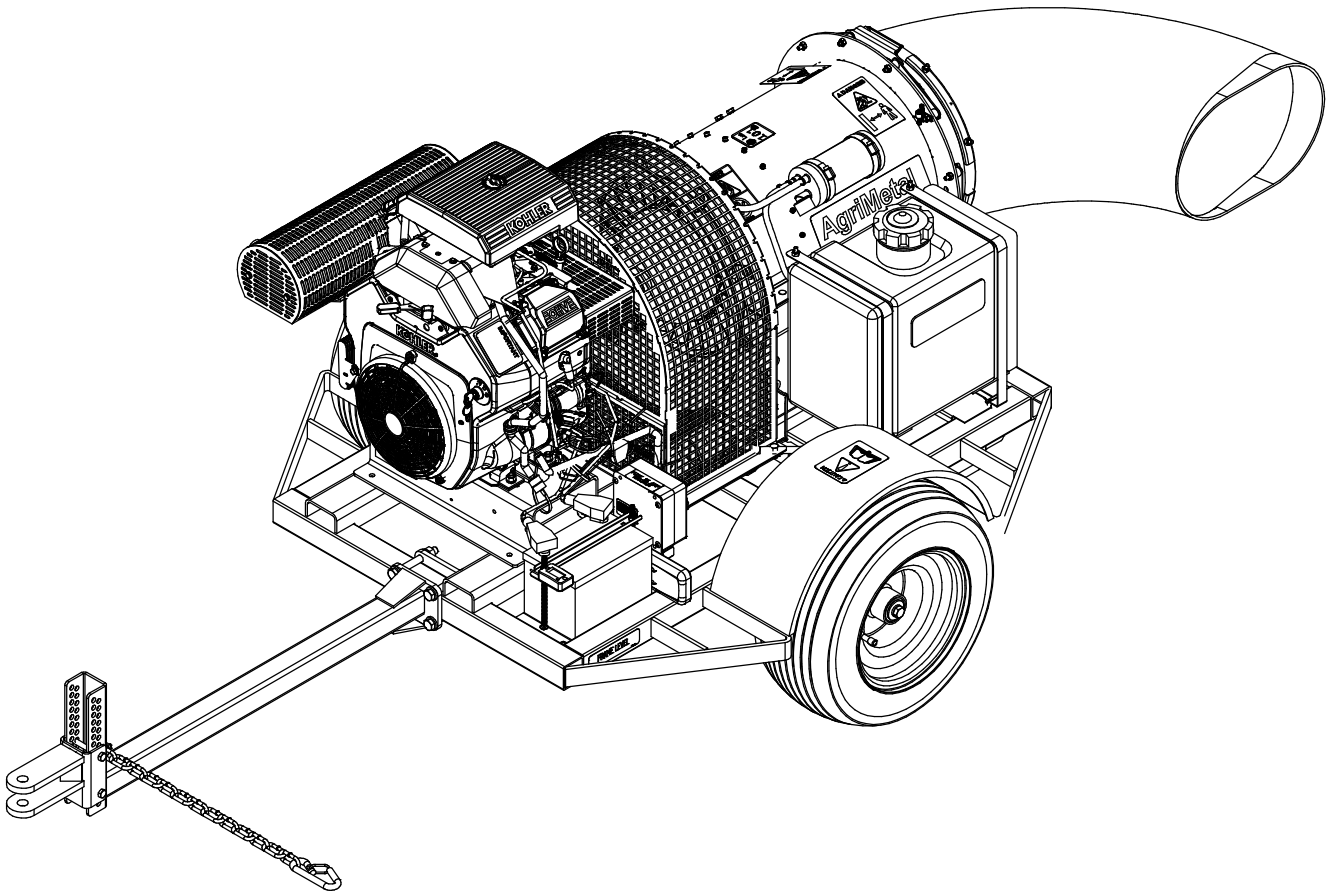

## TURBINE BLOWER 270 CARB

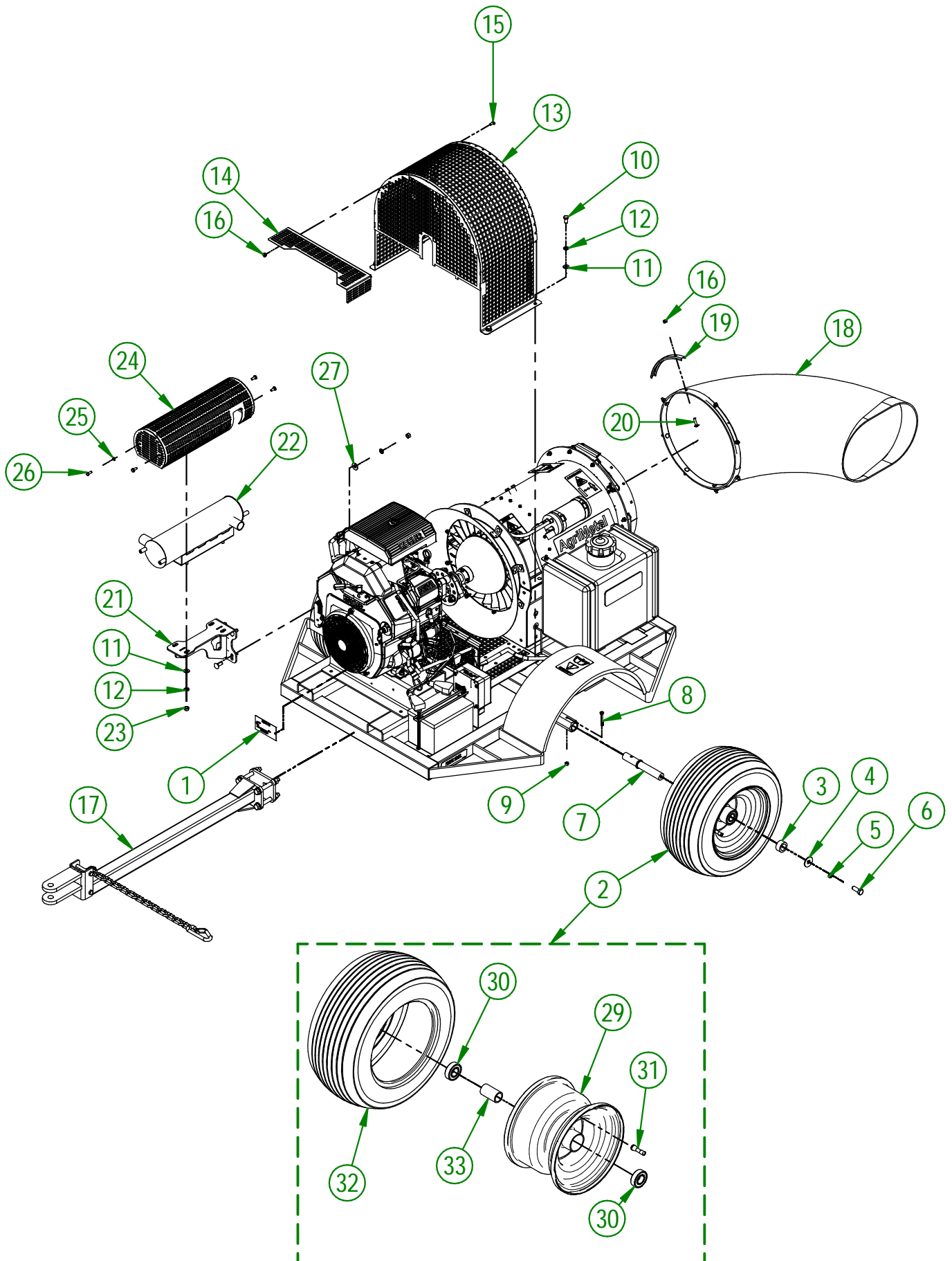

**AGRIMETAL**

**TURBINE BLOWER 270 CARB**

CREATION : 18/09/18  
 REVISION : 06/12/22

ASSEMBLY : **33-99-2506**  
 AUTHOR : J.KABWE

## 33-99-2506

#	PART #	Qty	TITLE
1	25-55-0710	1	SERIAL NUMBER PLATE
2	33-55-0125	2	ASSEMBLY WHEEL 18X9.50-8 WITH BALL BEARING
3	33-21-0065	2	WHEEL BUSHING
4	01-01-1660	2	WASHER SPACER
5	NC02-32-0014	2	LOCK WASHER ZINC 1/2"
6	NC01-17-0248	2	HEX. BOLT GR2 ZINC 1/2-13 X 1 1/4"
7	33-13-0100	2	AXLE SHAFT
8	NC01-33-0010	2	GRADE 8 HEX HEAD SCREW 1/4-20 X 2" LG.
9	NC01-93-0001	2	HEX. NUT NC ZINC 1/4-20
10	NC01-17-0112	4	HEX. BOLT GR2 ZINC 3/8-16 X 3/4"
11	01-01-2485	8	FLAT WASHER 14 GA X 13/16"OD X 25/64" ID
12	NC02-32-0012	12	LOCK WASHER ZINC 3/8"
13	33-50-0035	1	TURBINE GUARD (TB-270-240)
14	33-01-0025	1	EXHAUST TUBE GUARD
15	NC01-04-0001	5	CARR. BOLT GR2 ZINC 1/4-20 X 1/2"
16	NC01-96-0009	13	NYLON-INSERT LOCKNUT ZINC 1/4-20
17	33-55-0040	1	HITCH ASSEMBLY
18	33-42-0005	1	90° PLASTIC ELBOW
19	33-01-2480	4	DUCT CLAMP
20	NC01-04-0005	8	CARR. BOLT GR2 ZINC 1/4-20 X 1"
21	22-50-0300	1	MUFFLER SUPPORT (KOHLER 27 HP)
22	33-50-1050	1	27 HP KOHLER MUFFLER
23	NC02-07-0018	8	HEX. NUT ZINC 3/8-16
24	33-50-1055	1	MUFFLER GUARD (27 HP KOHLER)
25	NC02-32-0010	4	LOCK WASHER ZINC 1/4"
26	NC01-29-0003	4	HEX. BOLT GR5 ZINC 1/4-28 X 5/8"
27	21-01-0950	4	FLAT WASHER 10GA 1.005" DIA X 25/64"
28	NC01-04-0109	4	CARR. BOLT GR2 ZINC 3/8-16 X 1"

## 33-55-0125

#	PART #	Qty	TITLE
29	NC14-70-0320	1	RIM FOR NC14-70-0317
30	NC14-55-0330	2	6205-2RSI BEARING
31	NC14-70-0322	1	VALVE FOR NC14-70-0317
32	NC14-70-0319	1	WHEEL 18X9.50-8 (TURBINE)
33	33-10-0015	1	INSIDE WHEEL SPACER

#	PART #	QTY	TITLE
1	NCI3-25-0369	1	ELECTRIC BOX TB 270
2	NC02-42-0096	4	PHILLIPS SCREW ZINC #14 X 5/8"
3	NCI3-15-0055	1	INSULATING ROLLED COLLAR 7/16"ID X 15/16"OD X 5/16"T
4	NCI3-25-0019	10	BLACK TIE RAP
5	33-22-2240	1	WIRE PROTECTOR
6	NCI3-25-0374	1	WIRE 46"(NEW BOX)
7	33-57-0076	1	REMOTE CONTROL GROUP.

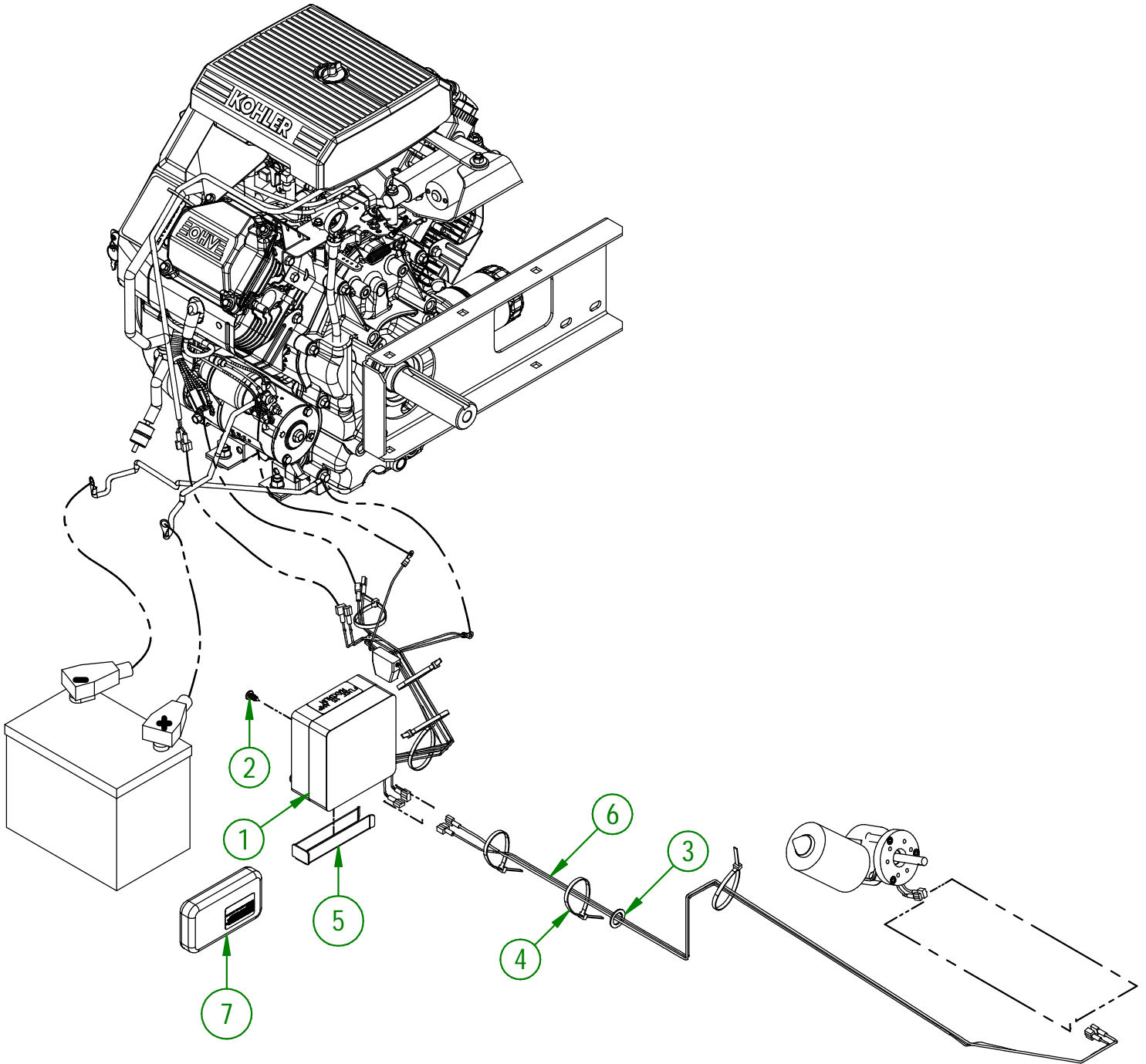

<b>AGRIMETAL</b>	
<b>TURBINE BLOWER 270</b>	
CREATION : 23/02/24	ASSEMBLY : <b>33-99-2506</b>
REVISION : 23/02/24	AUTHOR : J.KABWE

TB 270

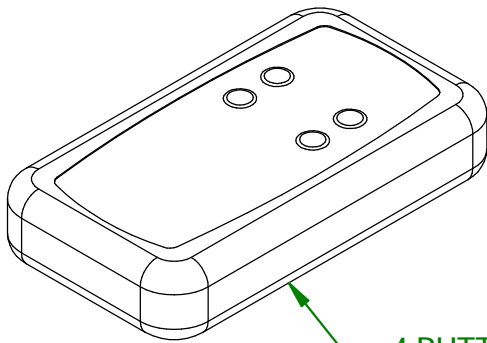
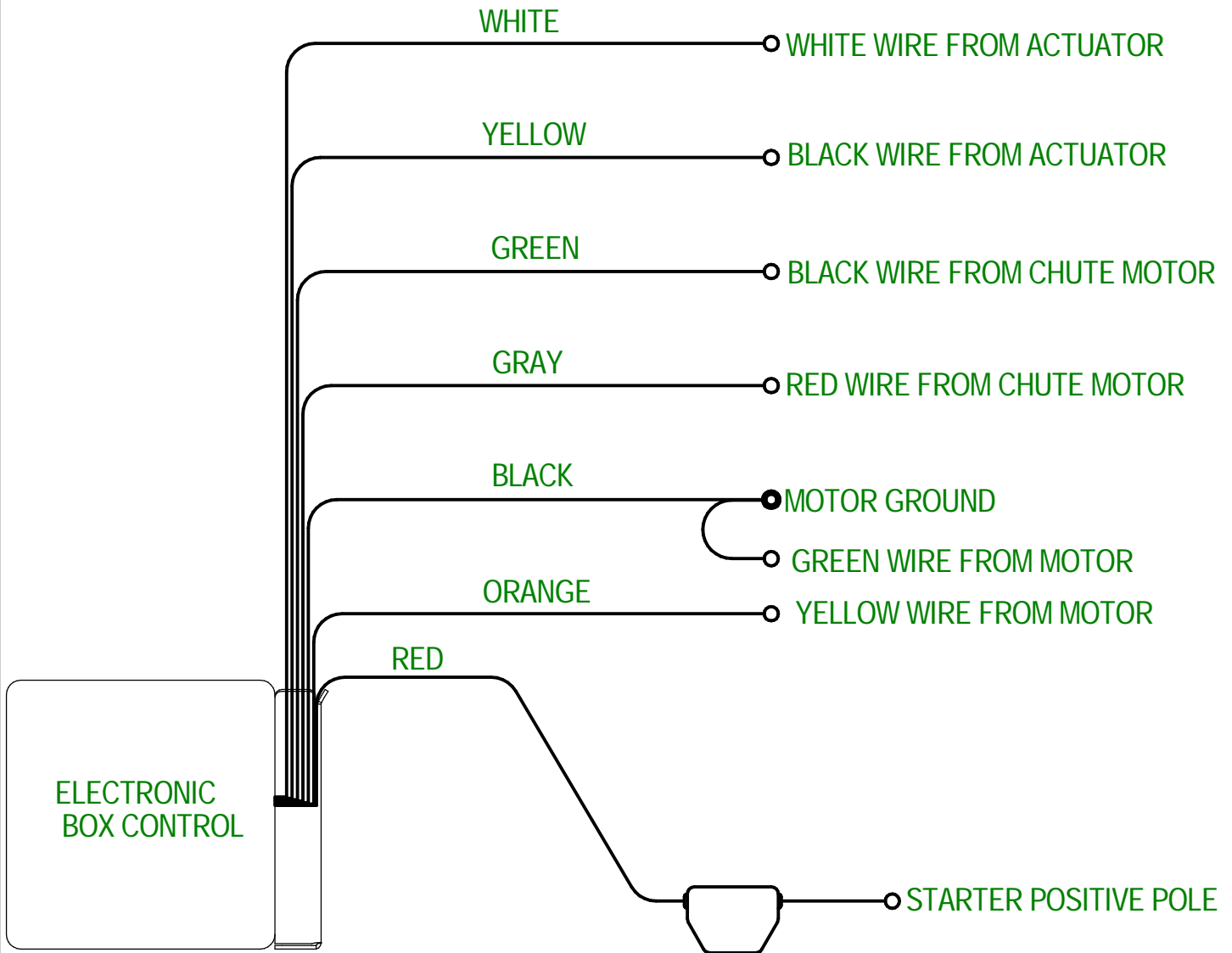

4 BUTTONS REMOTE CONTROL

<b>AGRIMETAL</b>	
ELECTRONIC BOX CONTROL GROUP.	
CREATION : 12/02/24	ASSEMBLY : <b>33-57-0006</b>
REVISION : 12/02/24	AUTHOR : J.KABWE

#	PART #	Qty	TITLE
1	NCI3-80-0248	1	GAS TANK
2	NCI3-80-0266	1	1/4" ON-OFF GAS VALVE
3	NCI3-80-0265	1	GROMMET VITRON #46866I
4	NCI3-80-0247	1	GAS CAP
5	33-01-3045	2	GAS TANK STRAP
6	33-46-0532	1	GAS HOSE 1/2" DIA.X 1/4" D.I. X 37"
7	NC01-04-0002	4	CARR. BOLT GR2 ZINC 1/4-20 X 5/8"
8	NC01-96-0009	4	NYLON-INSERT LOCKNUT ZINC 1/4-20
9	NC01-65-0201	2	SPRING -GRIP HOSE CLAMPS 1/2" O.D

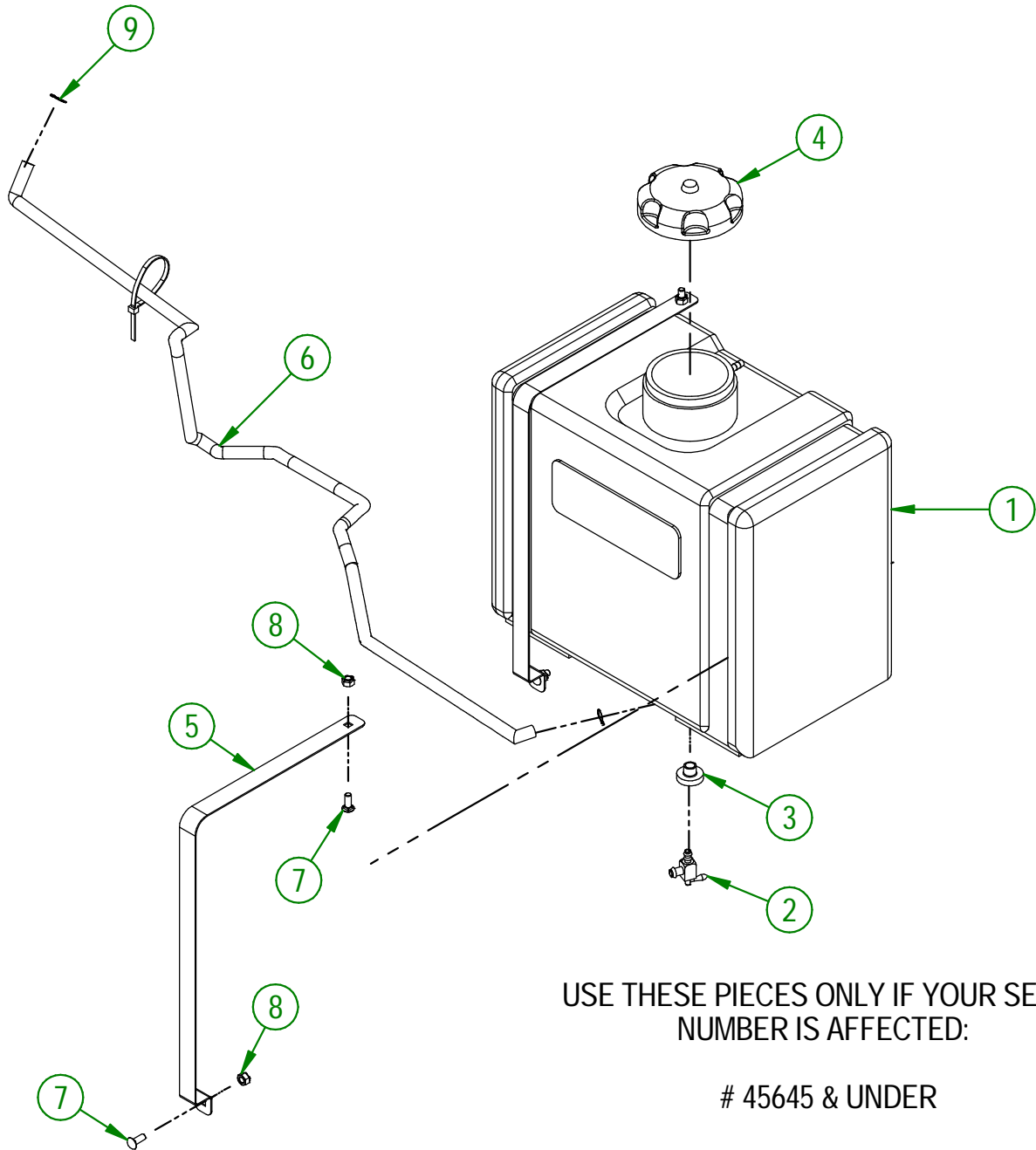

<b>AGRIMETAL</b>	
<b>GAS TANK ASSEMBLY</b>	
CREATION : 02/11/17	ASSEMBLY : <b>33-57-0130</b>
REVISION : 28/05/24	AUTHOR : J.KABWE

#	PART #	Qty	TITLE
1	NC13-80-0321	1	GAS TANK
2	NC13-80-0247	1	GAS CAP
3	33-46-0035	1	1/4" GAZ LINE X 12" LG
4	NC13-80-0324	1	GROMMET VITRON
5	NC13-80-0323	1	90° ELBOW X 1/4" GAS LINE
6	33-13-0015	1	GAZ LINE WEIGH
7	33-01-3045	2	GAS TANK STRAP
8	33-46-0545	1	GAS HOSE 1/2" DIA X 1/4" D.I. X 50"
9	NC01-04-0002	4	CARR. BOLT GR2 ZINC 1/4-20 X 5/8"
10	NC01-96-0009	4	NYLON-INSERT LOCKNUT ZINC 1/4-20
11	NC01-65-0201	2	SPRING -GRIP HOSE CLAMPS 1/2" O.D
12	NC13-25-0019	3	BLACK TIE RAP

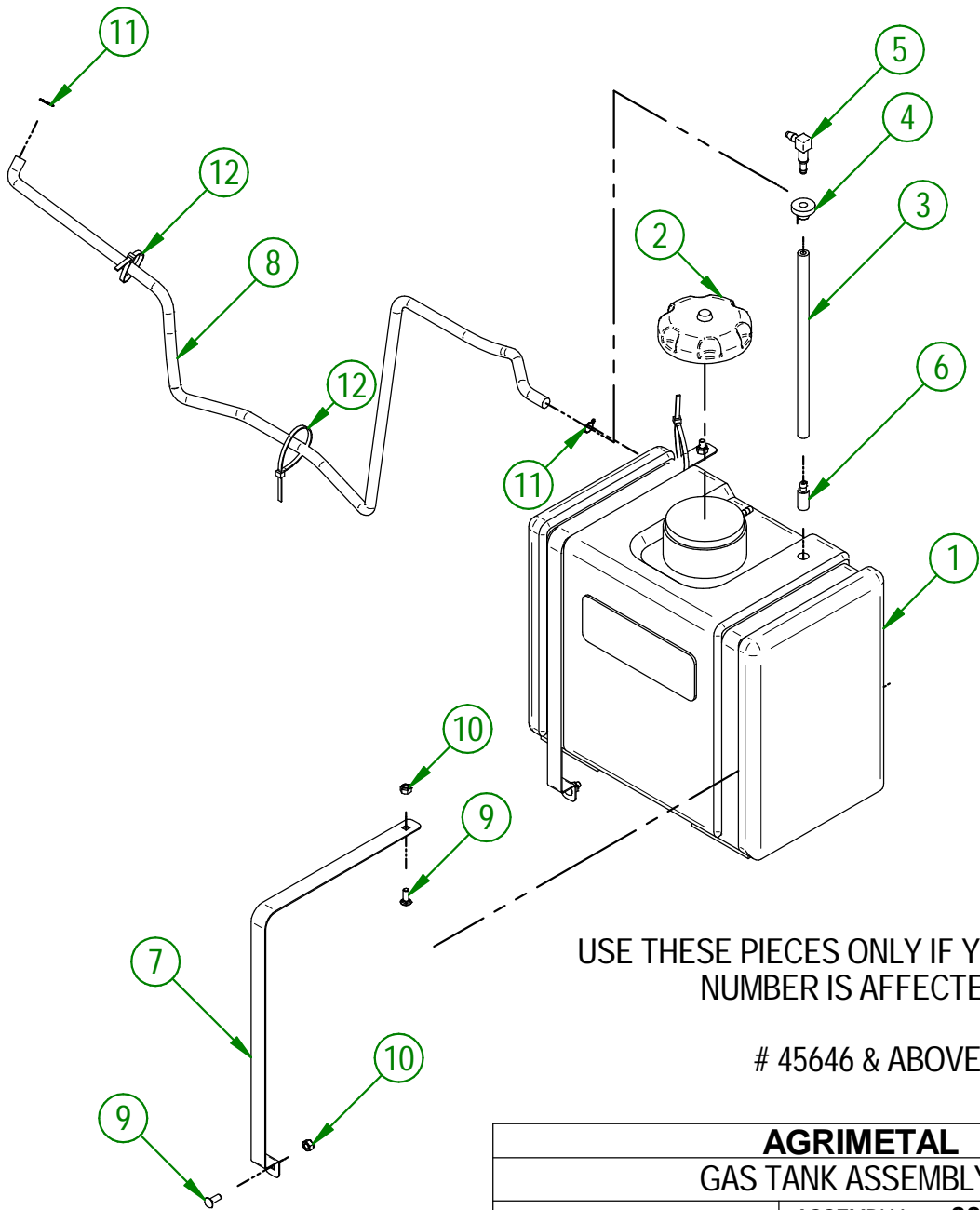

USE THESE PIECES ONLY IF YOUR SERIAL NUMBER IS AFFECTED:

# 45646 & ABOVE

<b>AGRIMETAL</b>	
<b>GAS TANK ASSEMBLY</b>	
CREATION : 15/05/24	ASSEMBLY : <b>33-57-0165</b>
REVISION : 28/05/24	AUTHOR : D. CHASSÉ

33-57-2520

#	PART #	Qty	TITLE
1	NC01-37-0263	4	HEX. BOLT GR8 NF ZINC 1/2-20 X 5" LG
2	NC02-22-0012	4	WASHER ZINC 1/2 BOLT = 9/16"Ø X 1 3/8" OD
3	NC01-94-0013	4	NYLON NUT ZINC 1/2-20"
4	33-57-2501	1	ASSEMBLY FRAME STICKER INCLUDED
5	33-57-0215	1	ENGINE BASE GROUP
6	33-01-0335	1	SHIELD PLATE
7	NC01-07-0107	2	CARR. BOLT GR2 ZINC 3/8-16 X 3/4"
8	01-01-2485	2	FLAT WASHER 14 GA X 13/16"OD X 25/64" ID
9	NC01-93-0011	2	LOCK NUT 3/8-16

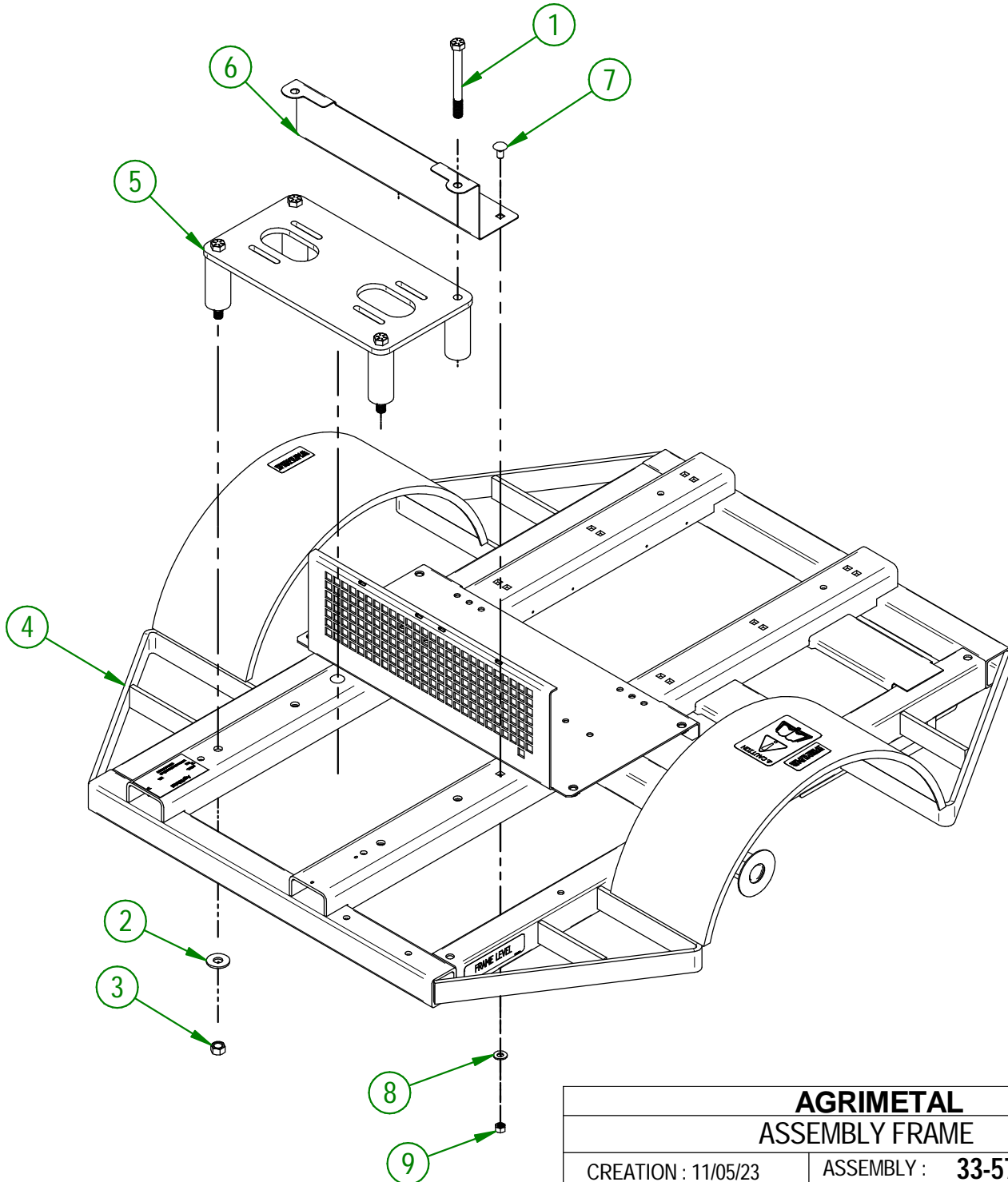

<b>AGRIMETAL</b>	
<b>ASSEMBLY FRAME</b>	
CREATION : 11/05/23	ASSEMBLY : <b>33-57-2520</b>
REVISION : 25/06/24	AUTHOR : D. CHASSÉ



#	PART #	Qty	TITLE
1	33-50-0010	1	DRAW BAR
2	33-50-0055	1	WELD ASSEMBLY HAND
3	33-04-0605	1	HITCH PLATE
4	NC01-17-0123	2	HEX. BOLT GR2 ZINC 3/8-16
5	NC02-32-0012	2	LOCK WASHER ZINC 3/8"
6	NC02-07-0018	2	HEX. NUT ZINC 3/8-16
7	01-01-0925	8	WASHER
8	NC02-32-0014	4	LOCK WASHER ZINC 1/2"
9	NC02-07-0020	4	HEX. NUT ZINC 1/2-13
10	NC01-17-0259	4	HEX. BOLT GR2 ZINC 1/2-13 X 4"
11	NC01-17-0116	1	HEX. BOLT GR2 ZINC 3/8-16 X 1 1/2"
12	21-01-0950	3	FLAT WASHER IOGA 1.005" DIA X 25/64"
13	55-41-0000	1	SAFETY CHAIN
14	NC01-96-0011	1	NYLON NUT 3/8-16

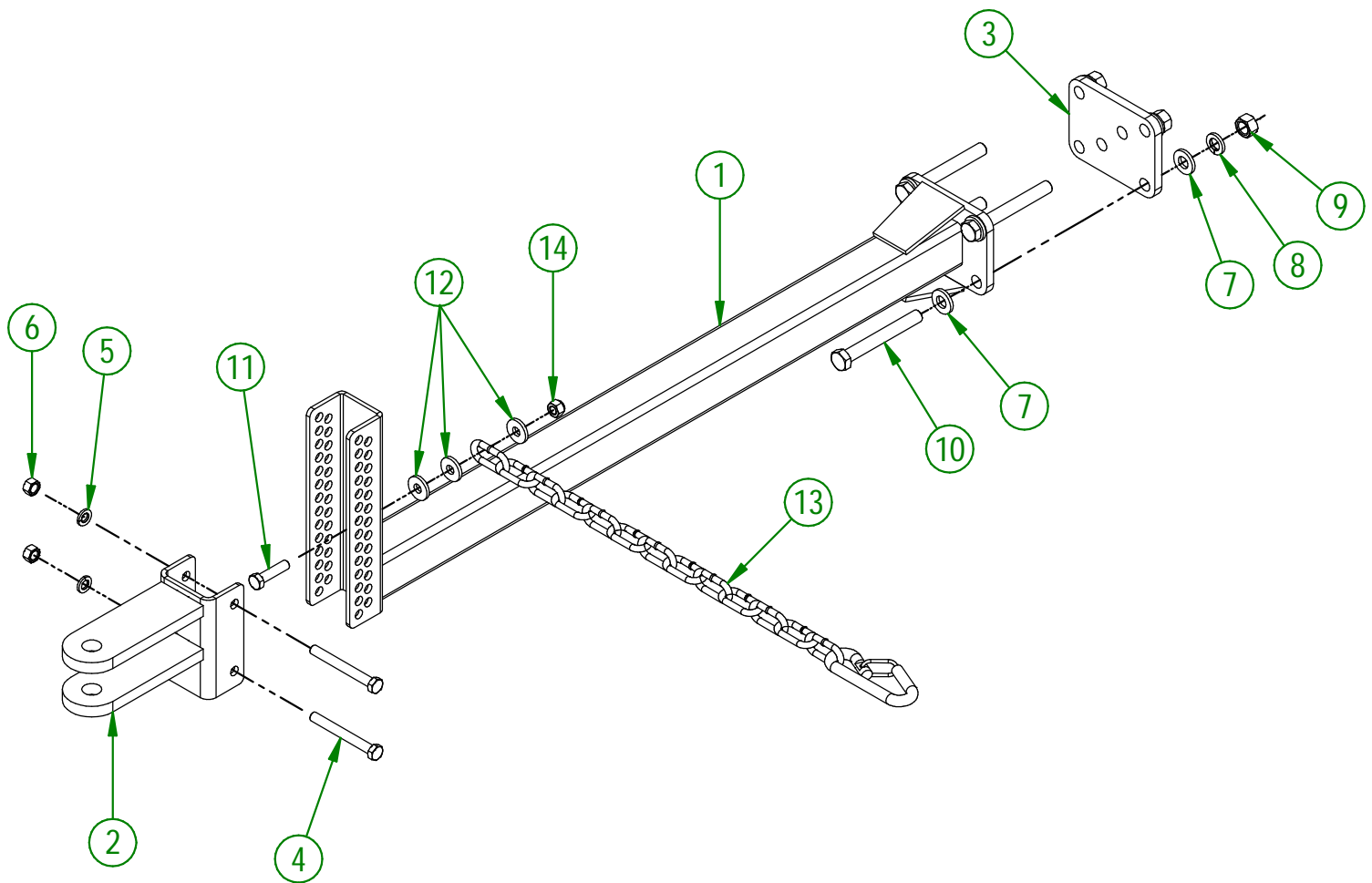

<b>AGRIMETAL</b>	
<b>HITCH ASSEMBLY</b>	
CREATION : 27/10/17	ASSEMBLY : <b>33-55-0040</b>
REVISION : 24/02/22	AUTHOR : J.KABWE

#	PART #	Qty	TITLE
1	NC01-02-0112	4	CARR. BOLT GR2 FLZ 3/8-16 X 1 3/4"
2	01-01-2485	4	FLAT WASHER 14 GA X 13/16"OD X 25/64" ID
3	NC02-32-0012	8	LOCK WASHER ZINC 3/8"
4	NC02-07-0018	8	HEX. NUT ZINC 3/8-16
5	33-22-2215	4	ENGINE SHIM ALU. 0.016" X 8.125" X 2"
6	33-22-5600	8	ENGINE STOPPER
7	NC01-04-0109	4	CARR. BOLT GR2 ZINC 3/8-16 X 1"

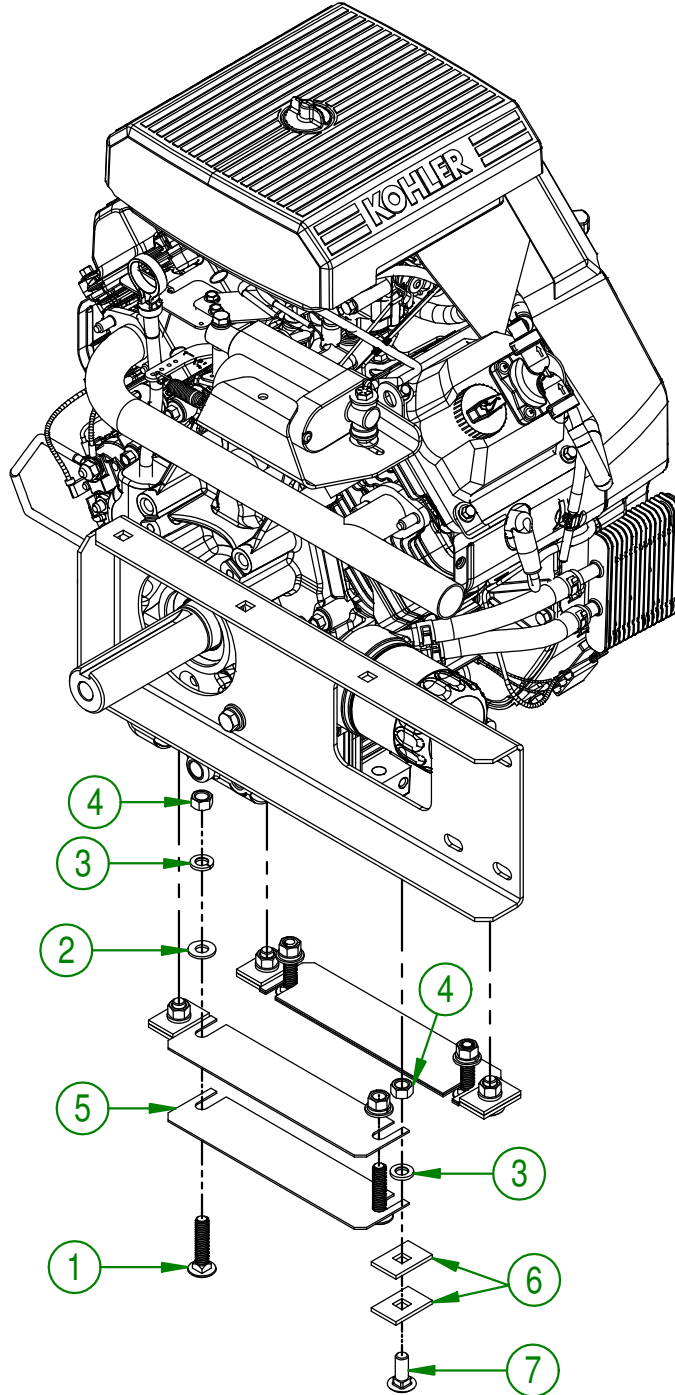
**AGRIMETAL****27 HP ENGINE GROUP.**

CREATION : 01/11/17  
 REVISION : 12/10/18

ASSEMBLY : **33-57-2541**

AUTHOR : J.KABWE

Page 8 de 19

#	PART #	Qty	TITLE
1	33-01-0900	1	MOFFLER SUPPORT
2	33-35-5000	1	EXHAUST MANIFOLD
3	33-55-0108	1	ASSEMBLY ACTUATOR 12 VOLTS
4	01-01-2485	4	FLAT WASHER 14 GA X 13/16"OD X 25/64" ID
5	NC02-32-0012	4	LOCK WASHER ZINC 3/8"
6	NC01-17-0114	4	HEX. BOLT GR2 ZINC 3/8-16 X 1"
7	33-55-1505	1	ASSEMBLY BATTERY RED CABLE #4
8	33-55-0090	1	ENGINE PLATE ASSY.
9	33-55-2500	1	ASSEMBLY BATTERY BLACK CABLE #4
10	NCI3-25-0110	1	SNUG-FIT DAMPING LOOP CLAMP
11	33-46-0527	1	1/4" GAS HOSE
12	NC01-45-0062	1	METR. BOLT GR 8.8 4MM X0.70P X 40MM

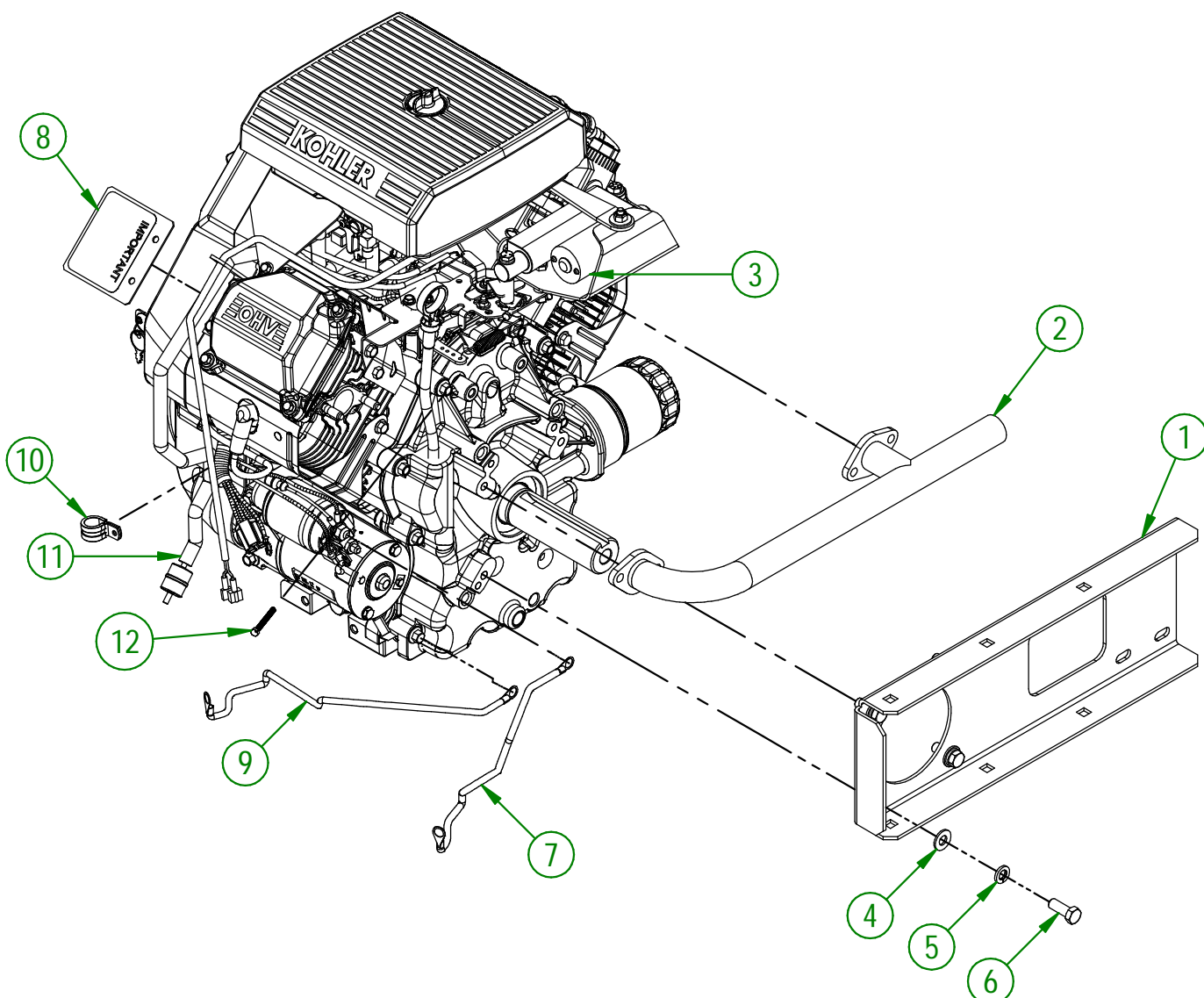

<b>AGRIMETAL</b>	
<b>27 HP KOHLER ENGINE STARTER ASSY.</b>	
CREATION : 01/11/17	ASSEMBLY : <b>33-55-2531</b>
REVISION : 06/02/24	AUTHOR : J.KABWE

#	PART #	Qty	TITLE
1	33-01-0040	1	ACTUATOR SUPPORT
2	NC01-37-0008	1	HEX. BOLT GR8 1/4-28 X 1 1/2"
3	NC01-37-0004	3	HEX. BOLT GR2 ZINC 1/4-28 X 3/4"
4	33-21-0070	1	ACTUATOR SUPPORT BUSHING
5	33-21-0075	1	ACTUATOR SUPPORT BUSHING
6	NC01-97-0004	4	NYLON-INSERT LOCKNUT ZINC 1/4-28
7	33-01-0045	1	ACTUATOR REINFORCING SUPPORT
8	36-01-2430	2	WASHER

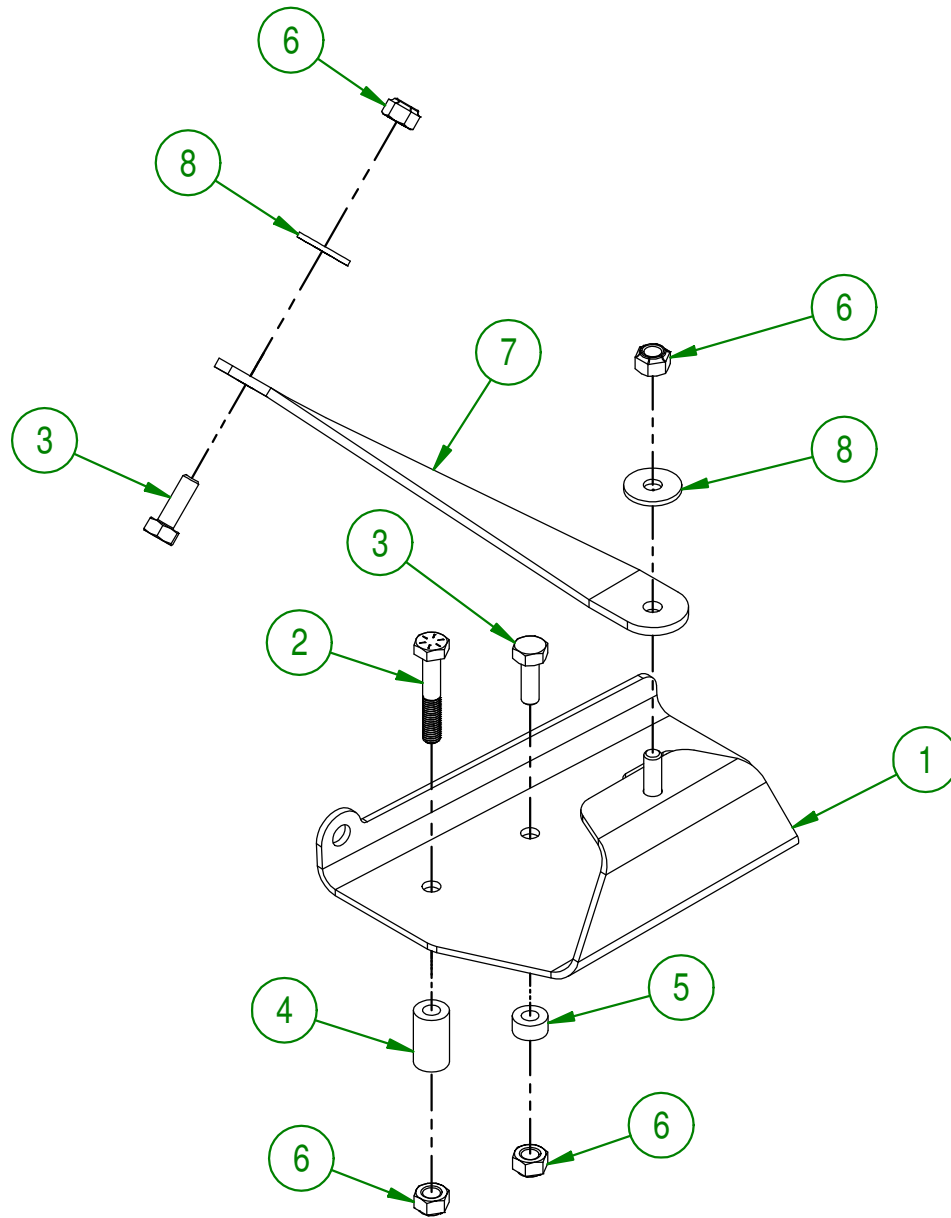

<b>AGRIMETAL</b>	
<b>ACTUATOR SUPPORT GROUP.</b>	
CREATION : 17/04/18	ASSEMBLY : <b>33-57-0104</b>
REVISION : 17/04/18	AUTHOR : J.KABWE   Page 10 de 19

#	PART #	Qty	TITLE
1	33-55-0100	1	ACTUATOR 12 VOLTS
2	33-57-0107	1	ACTION ROD
3	NC01-37-0011	1	HEX. BOLT GR8 1/4-28 X 2 1/4
4	33-42-0120	2	PIVOT BUSHING
5	NC02-14-1200	1	TWO WAY LOCK NUT 1/4-28
6	NC02-25-0007	4	WASHER ZINC 0.281 = 9/32
7	36-01-2430	2	FLAT WASHER 14GA X 17/64" I.D. X 13/16" O.D.
8	NC01-97-0004	1	NYLON-INSERT LOCKNUT ZINC 1/4-28

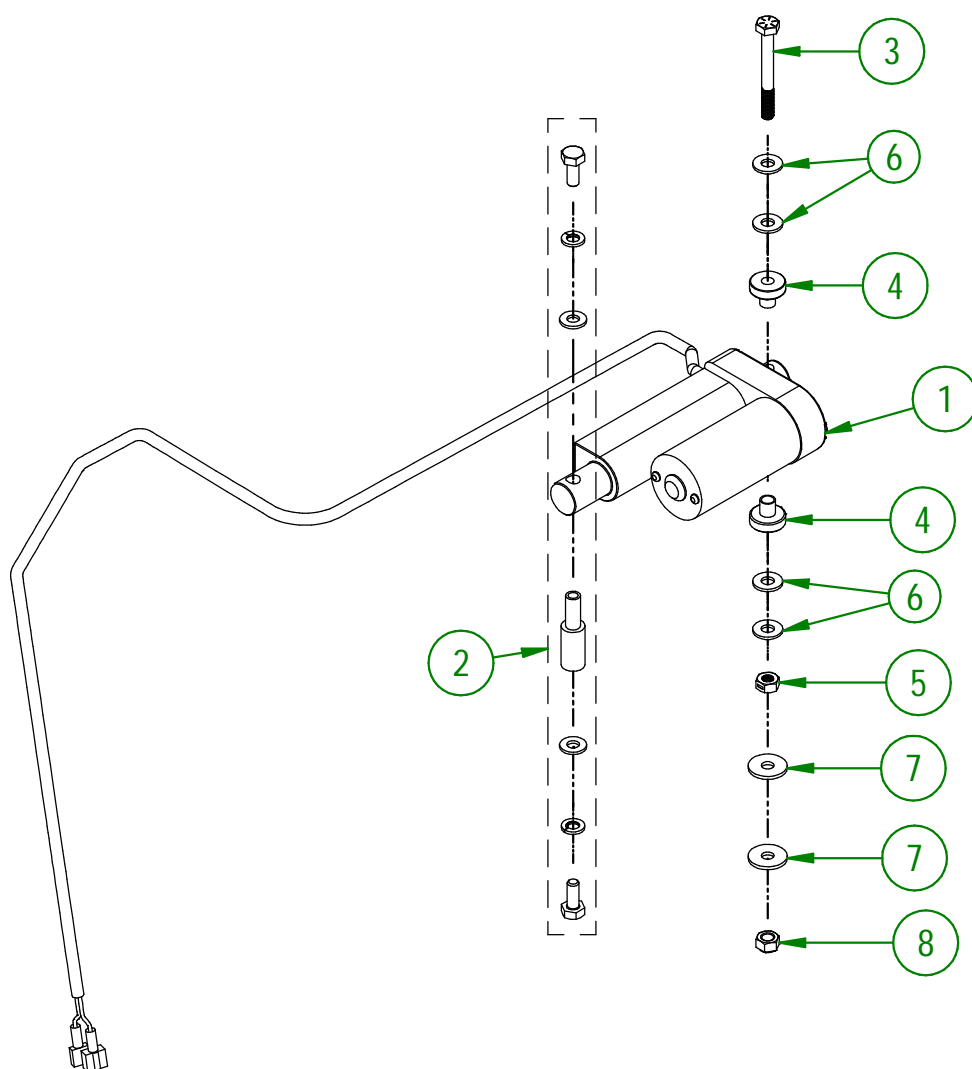

<b>AGRIMETAL</b>	
<b>ASSEMBLY ACTUATOR 12 VOLTS</b>	
CREATION : 17/04/18	ASSEMBLY : <b>33-55-0107</b>
REVISION : 12/05/23	AUTHOR : J.KABWE

#	PART #	Qty	TITLE
1	33-04-1600	2	FLANGE
2	33-21-0055	4	SLEEVE
3	01-01-0925	4	WASHER
4	33-01-7570	2	WASHER
5	NC14-62-0016	1	QD BUSHING SH I 1/4"
6	NC14-62-0211	1	QD BUSHING SH I 7/16"
7	33-20-0152	2	SPACER
8	NC01-37-0253	4	HEX. BOLT GR8 ZINC 1/2-20 X 2 1/2"
9	NC01-94-0013	4	NYLON NUT ZINC 1/2-20"
10	33-41-0920	1	SQUARE KEY

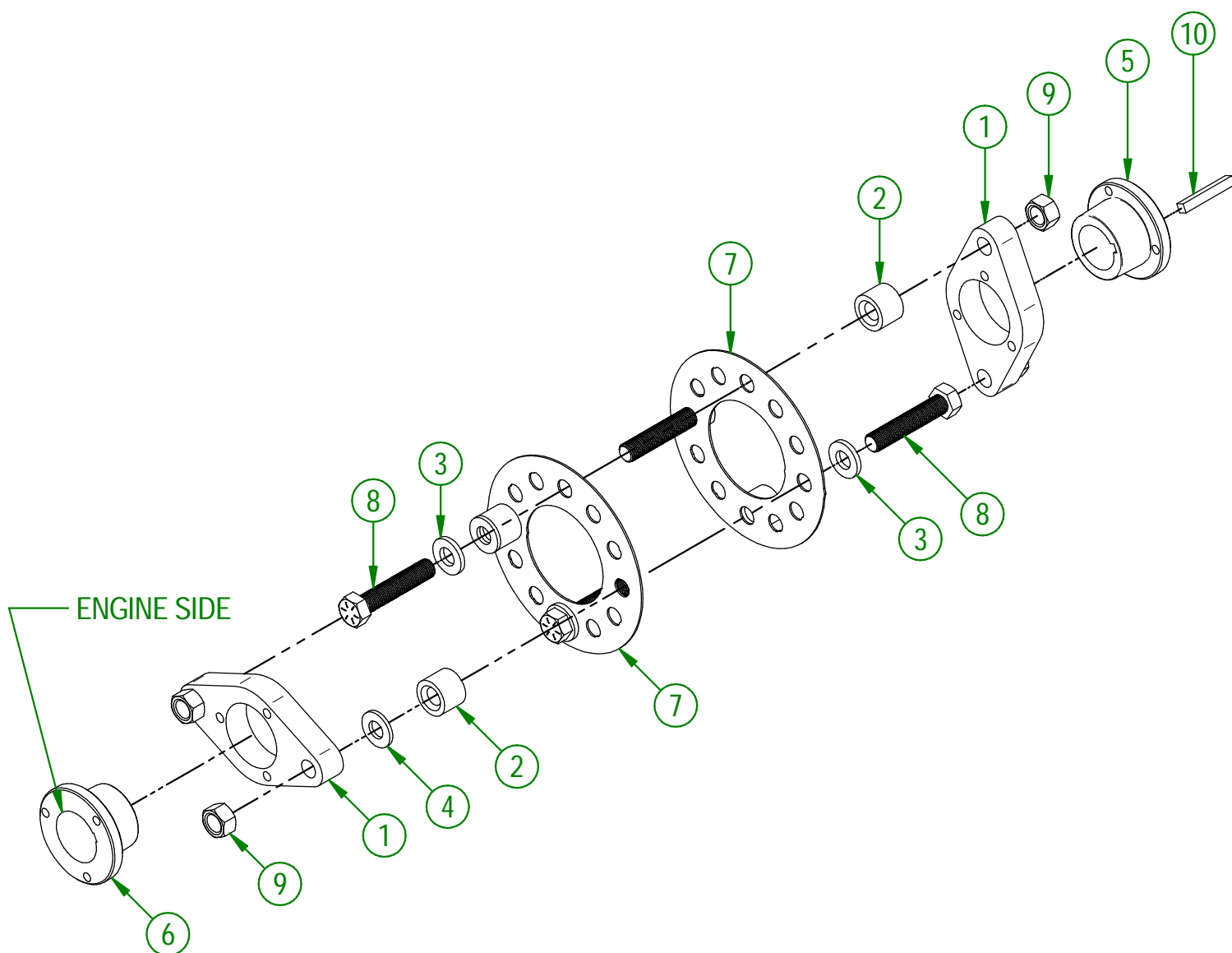

**AGRIMETAL**  
**COUPLING ASSEMBLY**

CREATION : 03/11/17  
 REVISION : 09/11/23

ASSEMBLY : **33-57-0046**  
 AUTHOR : J.KABWE

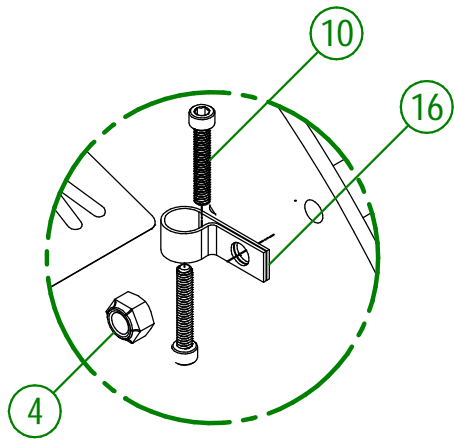
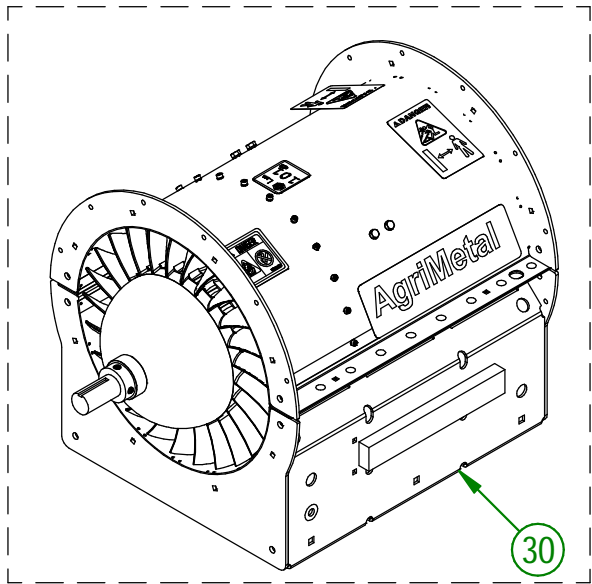

## DETAIL A

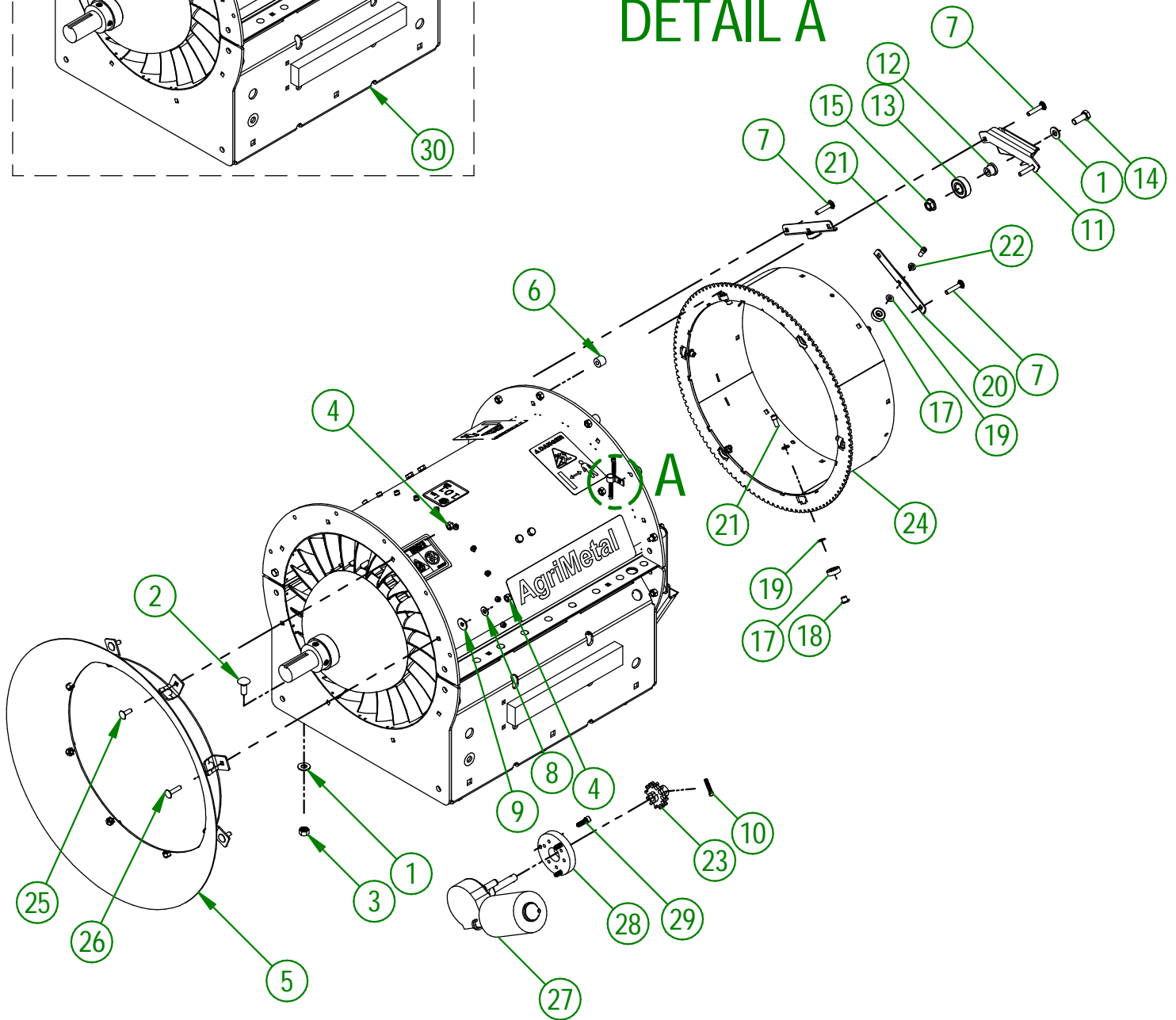

<b>AGRIMETAL</b>	
<b>REGROUP. TURBINE BLOWER</b>	
CREATION : 21/06/24	ASSEMBLY : <b>33-57-0080</b>
REVISION : 21/06/24	AUTHOR : D. CHASSÉ

## 33-57-0080

#	PART #	QTY	TITLE
1	01-01-2485	9	FLAT WASHER 14 GA X 13/16"OD X 25/64" ID
2	NC01-04-0109	6	CARR. BOLT GR2 ZINC 3/8-16 X 1"
3	NC01-93-0011	6	LOCK NUT 3/8-16
4	NC01-96-0009	41	NYLON-INSERT LOCKNUT ZINC 1/4-20
5	33-55-0085	1	AIR INTAKE ASSY.
6	33-21-0080	12	SPACER
7	NC01-04-0006	12	CARR. BOLT GR2 ZINC 1/4-20 X 1 1/4"
8	NC02-25-0007	2	WASHER ZINC 0.281 = 9/32
9	36-01-2430	3	FLAT WASHER 14GA X 17/64" I.D. X 13/16" O.D.
10	NC02-50-0069	3	SOCKET CAP SCREW T. RON 8-32 X 1"
11	33-50-0555	3	WELD ASSEMBLY BEARING SUPPORT
12	33-21-0060	3	BEARING HOLDER
13	NC14-75-0068	3	BALL BEARING 99502H
14	NC01-17-0114	3	HEX. BOLT GR2 ZINC 3/8-16 X 1"
15	NC02-14-0019	3	FLANGE NUT HEX. NC 3/8-16 GR. B
16	NC13-25-0233	1	VINYLE PROTECTOR COLLAR
17	NC14-75-0153	12	BALL BEARING R6 2RS 3/8" X 7/8" X 0.281"
18	33-25-2410	12	BEARING BUSHING
19	33-03-4605	12	BEARING SHIM 1/4" ALUMINUM
20	33-01-2425	6	BEARING HOLDER BRACKET
21	NC02-51-0578	12	SOCKET CAP SCREW T. RON. NF 1/4-28 X 1/2 STAINLESS
22	NC02-32-0010	12	LOCK WASHER ZINC 1/4"
23	33-55-0035	1	GEARED CROWN SPROCKET
24	33-50-0018	1	DUCT COLECTOR
25	NC01-04-0003	6	CARR. BOLT GR2 ZINC 1/4-20 X 3/4"
26	NC01-04-0005	2	CARR. BOLT GR2 ZINC 1/4-20 X 1"
27	33-35-0005	1	OUTLET MOTOR
28	33-21-0100	1	ENGINE CONVERSION PLATE
29	NC02-50-1072	3	SOCKET CAP SCREW M6 X 20mm
30	33-57-0020	1	REGROUP. ENSEMBLE DE TURBINE (NEUF)



#	PART #	Qty	TITLE
1	33-01-3210	1	CARBON CAN SUPPORT
2	NCI3-80-0258	1	6 GALLON GAS CARBONE CAN
3	NC01-65-0065	2	SNUG-FIT DAMPING LOOP CLAMP 2 5/16"- 3 1/4" HAS44
4	NC01-65-0201	2	SPRING -GRIP HOSE CLAMPS 1/2" O.D
5	33-46-0543	1	GAS HOSE EPA 7/16" DIA.X 3/16" D.I. X 71" EPA & CARB
6	33-46-0570	1	GAS HOSE 1/2" DIA.X 1/4" DI X 23" CARB (TB-270)
7	NCI3-80-0286	2	HOSE CLAMPS 3/16" ID X 7/16" OD X FOR NCI3-80-0285

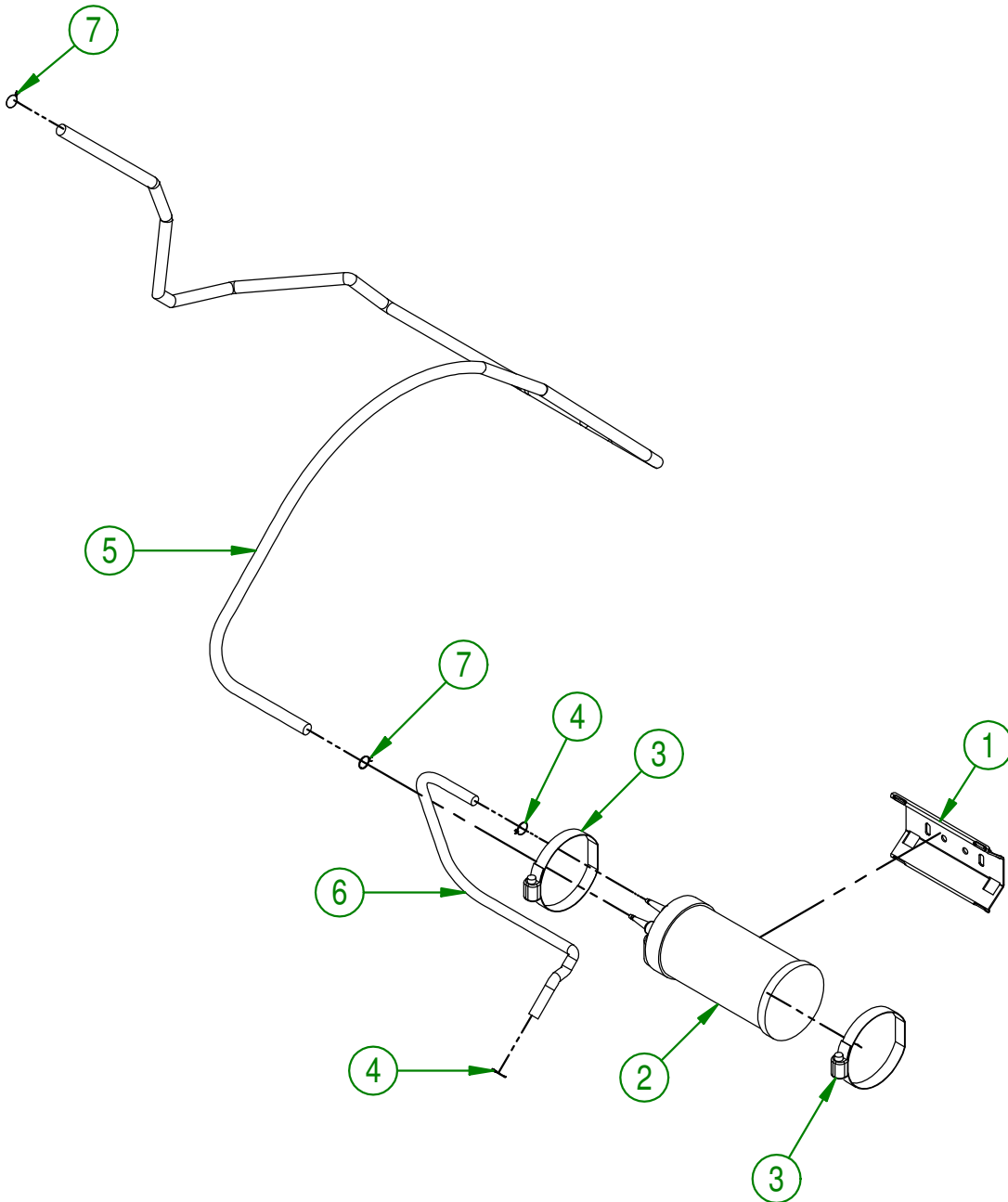

<b>AGRIMETAL</b>	
<b>PARTS CARB GROUP (TB-270 IC)</b>	
CREATION : 17/09/18	ASSEMBLY : <b>33-57-3520</b>
REVISION : 18/09/18	AUTHOR : J.KABWE   Page 15 de 19

#	PART #	Qty	TITLE
1	22-50-0300	1	MUFFLER SUPPORT (KOHLER 27 HP)
2	33-50-1050	1	27 HP KOHLER MUFFLER
3	01-01-2485	4	FLAT WASHER
4	NC02-32-0012	4	LOCK WASHER ZINC 3/8"
5	NC02-07-0018	4	HEX. NUT ZINC 3/8-16
6	33-50-1055	1	MUFFLER GUARD (27 HP KOHLER)
7	NC02-32-0010	4	LOCK WASHER ZINC 1/4"
8	NC01-29-0003	4	HEX. BOLT GR5 ZINC 1/4-28 X 5/8"

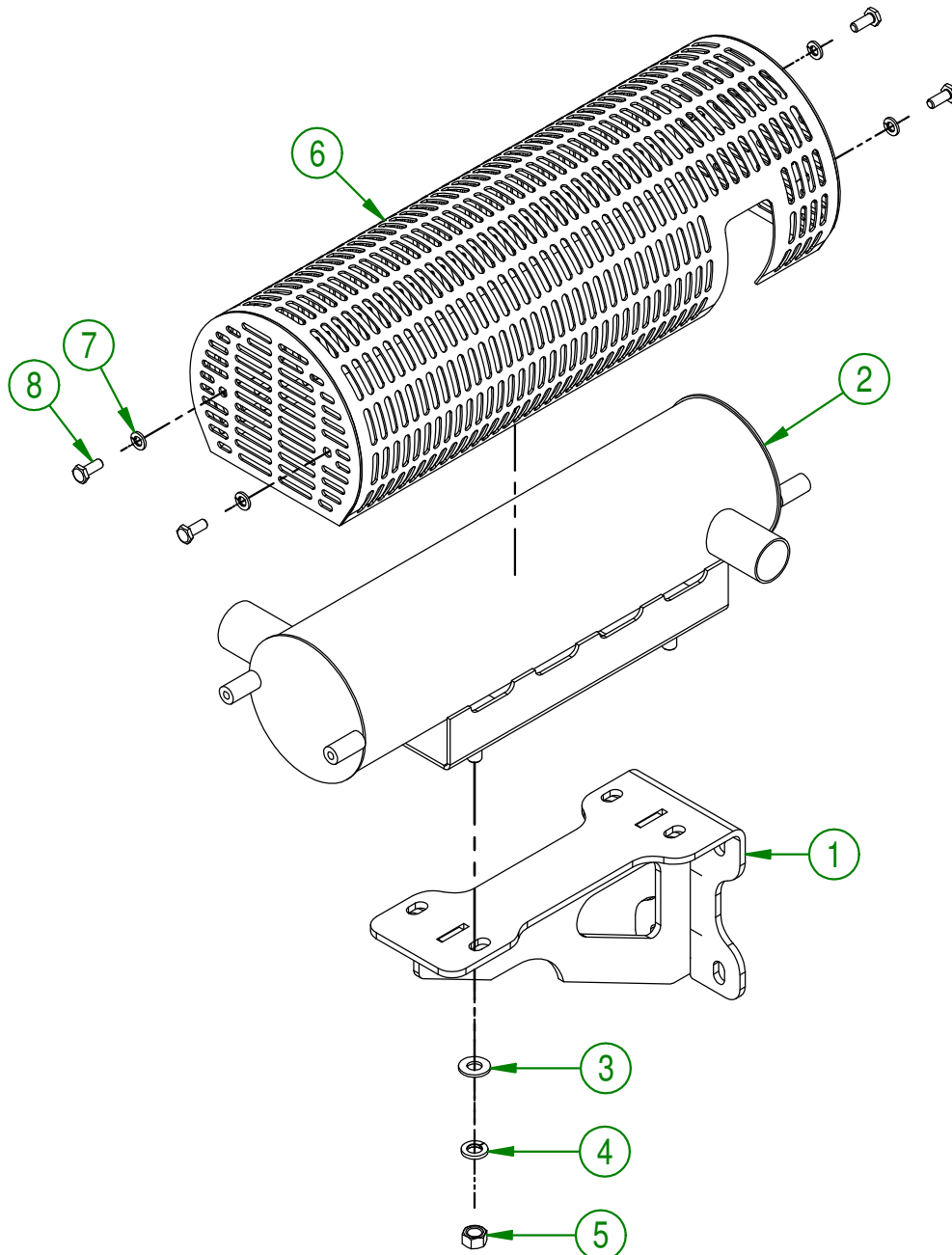

<b>AGRIMETAL</b>	
<b>MUFFLER SUPPORT &amp; MUFFLER ASSY.</b>	
CREATION : 01/11/17	ASSEMBLY : <b>33-55-0075</b>
REVISION : 08/01/18	AUTHOR : J.KABWE   Page 16 de 19

#	PART #	Qty	TITLE
1	NC01-96-0009	2	NYLON-INSERT LOCKNUT ZINC 1/4-20
2	NC01-04-0027	2	CARR. BOLT 1/4-20 X 6" LG
3	NC01-04-0056	2	CARR. BOLT 5/16-18 X3/4"
4	33-01-3015	1	BATTERY STRAPE
5	NC02-32-0011	2	LOCK WASHER ZINC 5/16"
6	NCI3-12-0001	1	12 VOLTS BATTERY
7	NC02-07-0017	2	HEX. NUT 5/16-18
8	NCI3-80-0267	1	RED PROTECTOR FOR BATTERY POST
9	NCI3-80-0268	1	BLACK PROTECTOR FOR BATTERY POST
10	33-01-4000	1	HOUR METER HOLDER
11	NCI3-37-0669	1	HOUR METER

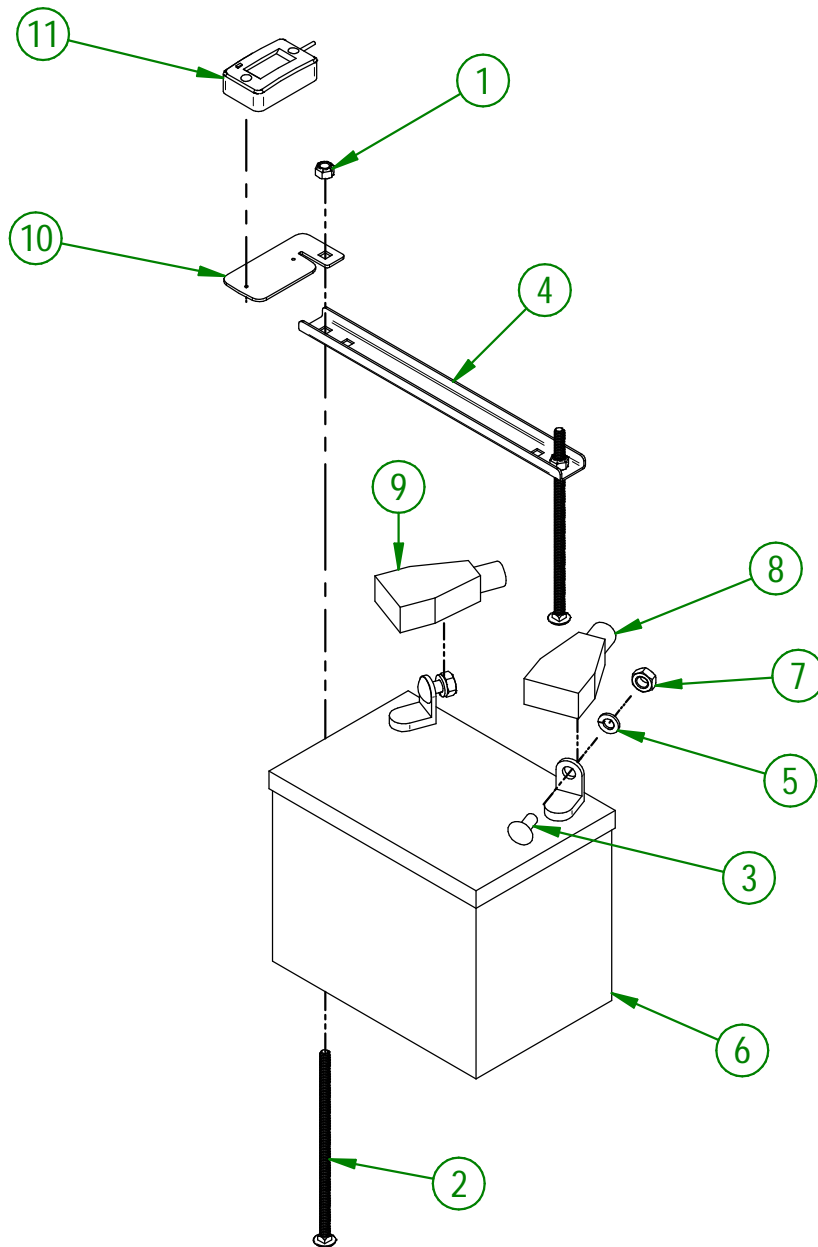

USE THESE PIECES ONLY IF YOUR SERIAL NUMBER IS AFFECTED:

BELOW # 44661

<b>AGRIMETAL</b>	
12 VOLTS BATTERY GROUP.	
CREATION : 31/10/17	ASSEMBLY : <b>33-57-0055</b>
REVISION : 11/09/23	AUTHOR : J.KABWE

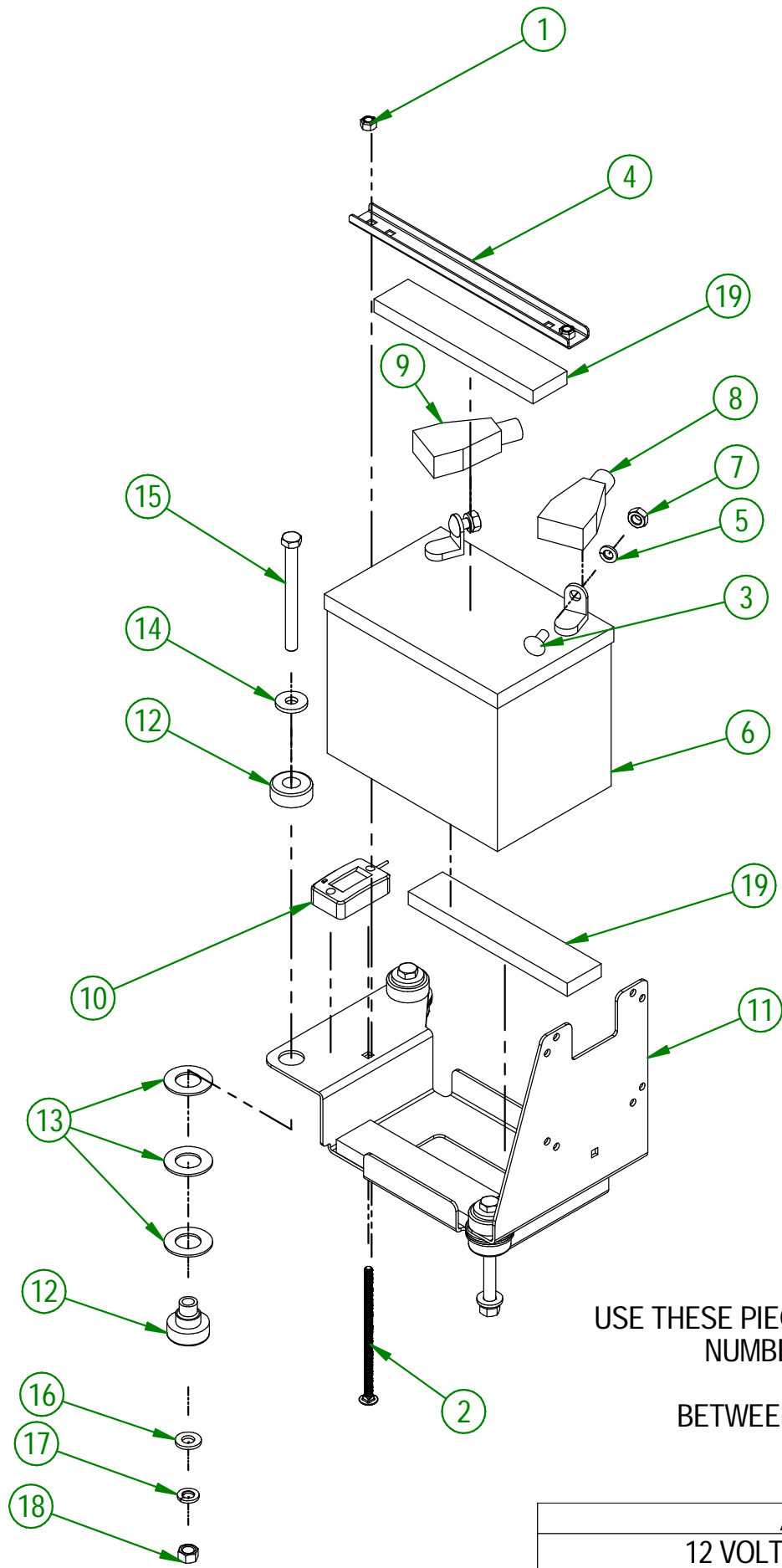

USE THESE PIECES ONLY IF YOUR SERIAL NUMBER IS AFFECTED:

BETWEEN #44661 & #45502

<b>AGRIMETAL</b>	
12 VOLTS BATTERY GROUP.	
CREATION : 29/08/23	ASSEMBLY : <b>33-57-0057</b>
REVISION : 05/07/24	AUTHOR : D. CHASSÉ

## 33-57-0057

#	PART #	Qty	TITLE
1	NC01-96-0009	2	NYLON-INSERT LOCKNUT ZINC 1/4-20
2	NC01-04-0024	2	CARR. BOLT GR2 ZINC 1/4-20 X 5"
3	NC01-04-0056	2	CARR. BOLT 5/16-18 X3/4"
4	33-01-3015	1	BATTERY STRAPE
5	NC02-32-0011	2	LOCK WASHER ZINC 5/16"
6	NC13-12-0017	1	12 VOLTS GEL BATTERY
7	NC02-07-0017	2	HEX. NUT 5/16-18
8	NC13-80-0267	1	RED PROTECTOR FOR BATTERY POST
9	NC13-80-0268	1	BLACK PROTECTOR FOR BATTERY POST
10	NC13-37-0669	1	HOUR METER
11	33-57-2400	1	BATTERY SUPPORT PLATE "INCL. STICKER"
12	NC13-15-0354	3	RED RUBBER BASE MOUNT
13	26-03-4800	9	WASHER
14	21-01-0950	3	FLAT WASHER 10GA 1.005" DIA X 25/64"
15	NC01-25-0126	3	HEX. BOLT GR5 ZINC 3/8-16 X 4"
16	NC02-25-0009	3	WASHER 0.406" I.D. X 0.815 O.D.
17	NC02-32-0012	3	LOCK WASHER ZINC 3/8"
18	NC02-07-0018	3	HEX. NUT ZINC 3/8-16
19	33-42-0130	3	BLACK ADHESIVE-BACK STRIP

#	PART #	Qty	TITLE
1	NC01-04-0056	2	CARR. BOLT 5/16-18 X3/4"
2	NC02-32-0011	2	LOCK WASHER ZINC 5/16"
3	NC13-12-0017	1	12 VOLTS GEL BATTERY
4	NC02-07-0017	2	HEX. NUT 5/16-18
5	NC13-80-0267	1	RED PROTECTOR FOR BATTERY POST
6	NC13-80-0268	1	BLACK PROTECTOR FOR BATTERY POST
7	NC13-37-0669	1	HOUR METER
8	33-57-2401	1	BATTERY SUPPORT PLATE "INCL. STICKER"
9	NC13-15-0354	3	RED RUBBER BASE MOUNT
10	26-03-4800	9	WASHER
11	21-01-0950	3	FLAT WASHER IOGA 1.005" DIA X 25/64"
12	NC01-25-0126	3	HEX. BOLT GR5 ZINC 3/8-16 X 4"
13	NC02-25-0009	3	WASHER 0.406" I.D. X 0.815 O.D.
14	NC02-32-0012	3	LOCK WASHER ZINC 3/8"
15	NC02-07-0018	3	HEX. NUT ZINC 3/8-16
16	33-42-0130	2	BLACK ADHESIVE-BACK STRIP
17	NC13-15-0008	1	RUBBER STRAP
18	33-42-0135	2	BLACK ADHESIVE-BACK STRIP

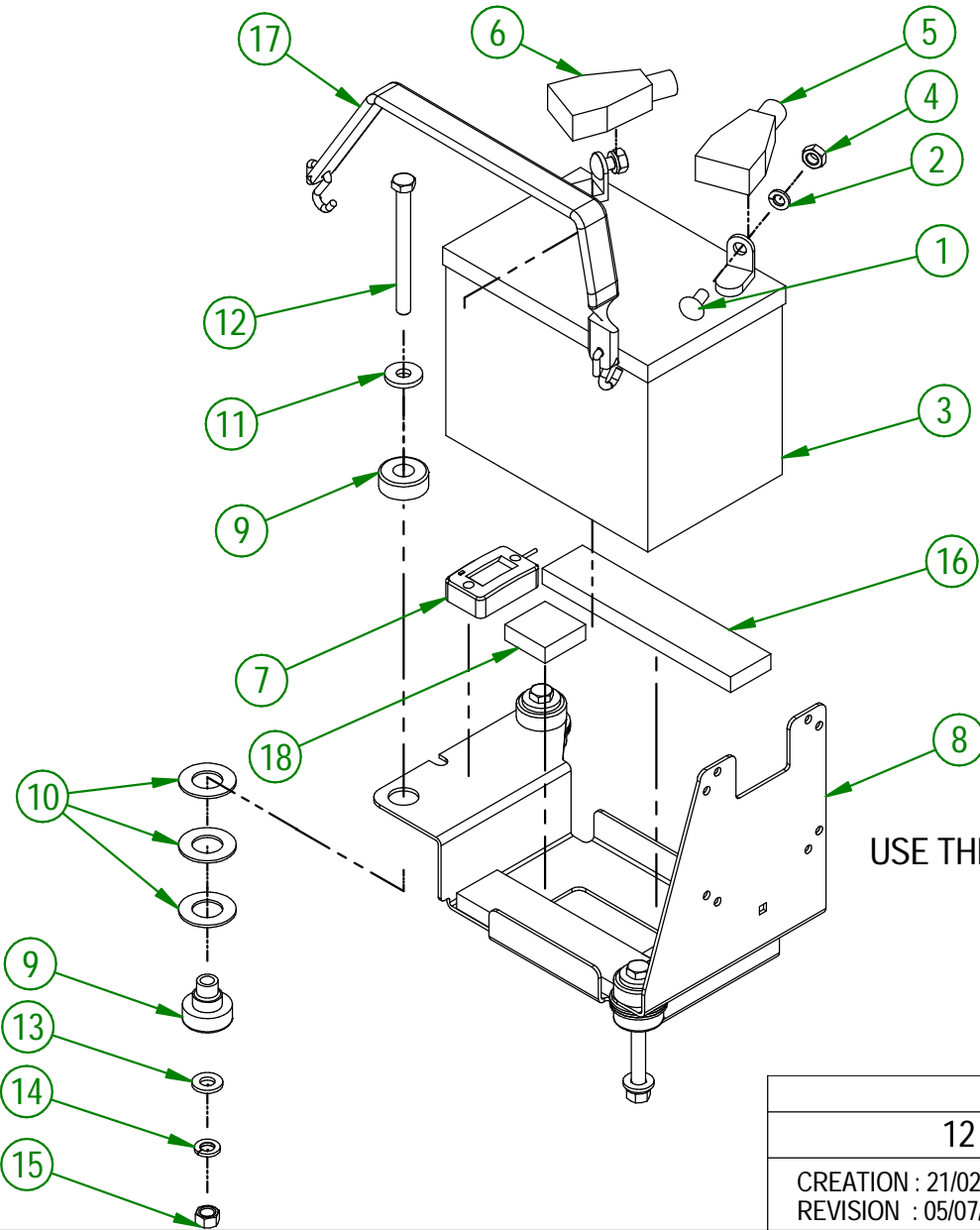

USE THESE PIECES ONLY IF YOUR SERIAL NUMBER IS AFFECTED:

#45503 AND ABOVE

<b>AGRIMETAL</b>	
12 VOLTS BATTERY GROUP.	
CREATION : 21/02/24	ASSEMBLY : <b>33-57-0170</b>
REVISION : 05/07/24	AUTHOR : D. CHASSÉ

#	PART #	Qty	TITLE
1	NCI3-30-0237	1	PLASTIC TUBE FOR OPERATOR'S MANUAL
2	NC01-04-0003	3	CARR. BOLT GR2 ZINC 1/4-20 X 3/4"
3	NC02-25-0007	3	WASHER ZINC 0.281 = 9/32
4	NC01-96-0009	3	NYLON-INSERT LOCKNUT ZINC 1/4-20
5	33-98-0621	1	OPERATION MANUAL TB 270

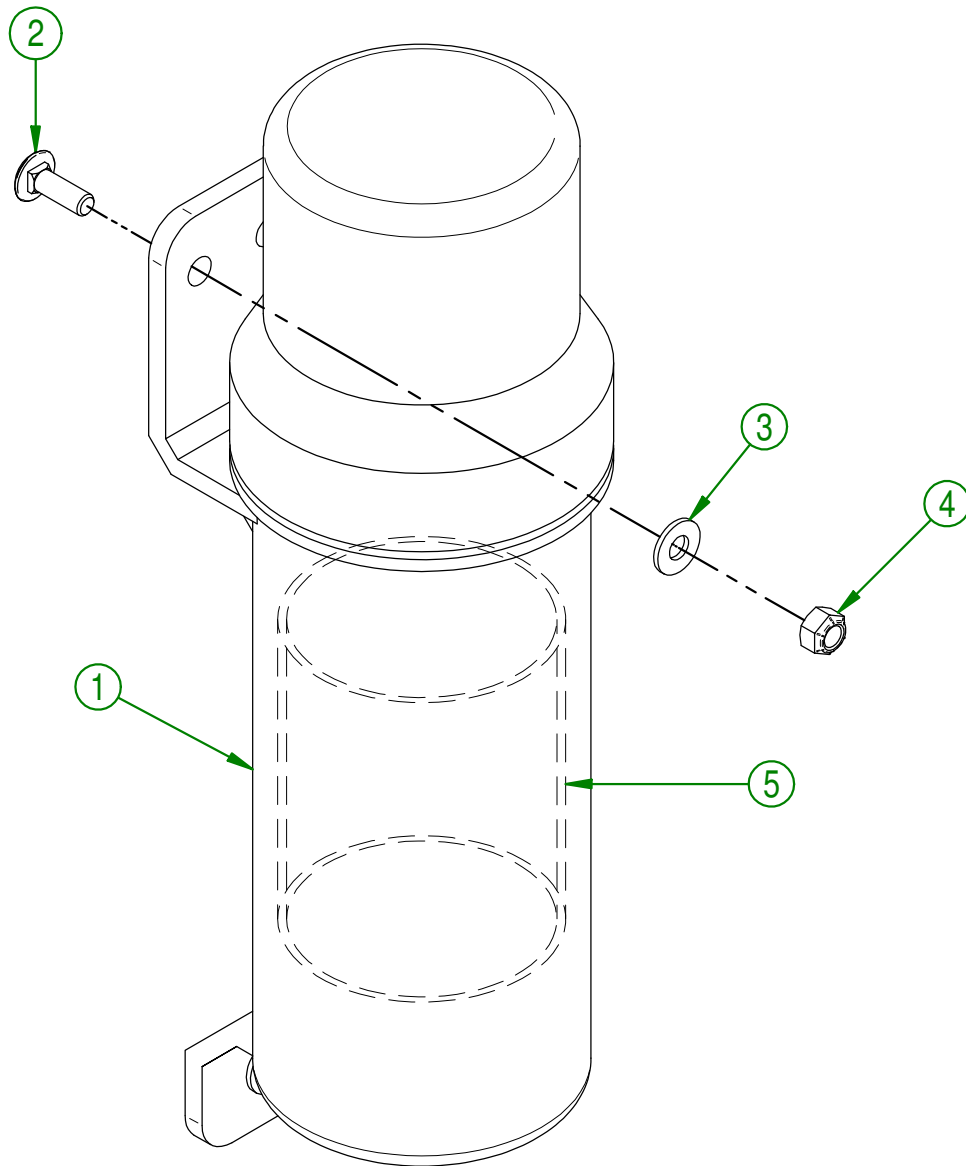

<b>AGRIMETAL</b>	
<b>OPERATOR MANUEL TUBE ASSEMBLY</b>	
CREATION : 14/02/18	ASSEMBLY : <b>33-57-2566</b>
REVISION : 05/10/18	AUTHOR : J.KABWE   Page 18 de 19

#	PART #	Qty	TITLE
1	NCI3-33-0052	2	STICKER FRAME LEVEL
2	NCI3-33-0183	1	STICKER CAUTION OPERATION MANUAL
3	NCI3-33-2675	2	STICKER TO INFLATE TIRE
4	NCI3-33-0227	1	STICKER FUSE 15 AMP MAXIMUM
5	NCI3-33-0192	2	STICKER (PROJECTION RISK)
6	NCI3-33-0185	1	STICKER PICTOGRAM (FIRE + CIGARETTE)
7	NCI3-33-0035	2	STICKER AGRIMETAL
8	NCI3-33-0129	1	STICKER 101 DB
9	NCI3-33-0178	1	STICKER IMPORTANT PLEASE CHECK OIL LEVEL...
10	NCI3-33-2674	2	STICKER TO PROGRAM REMOTE CONTROL

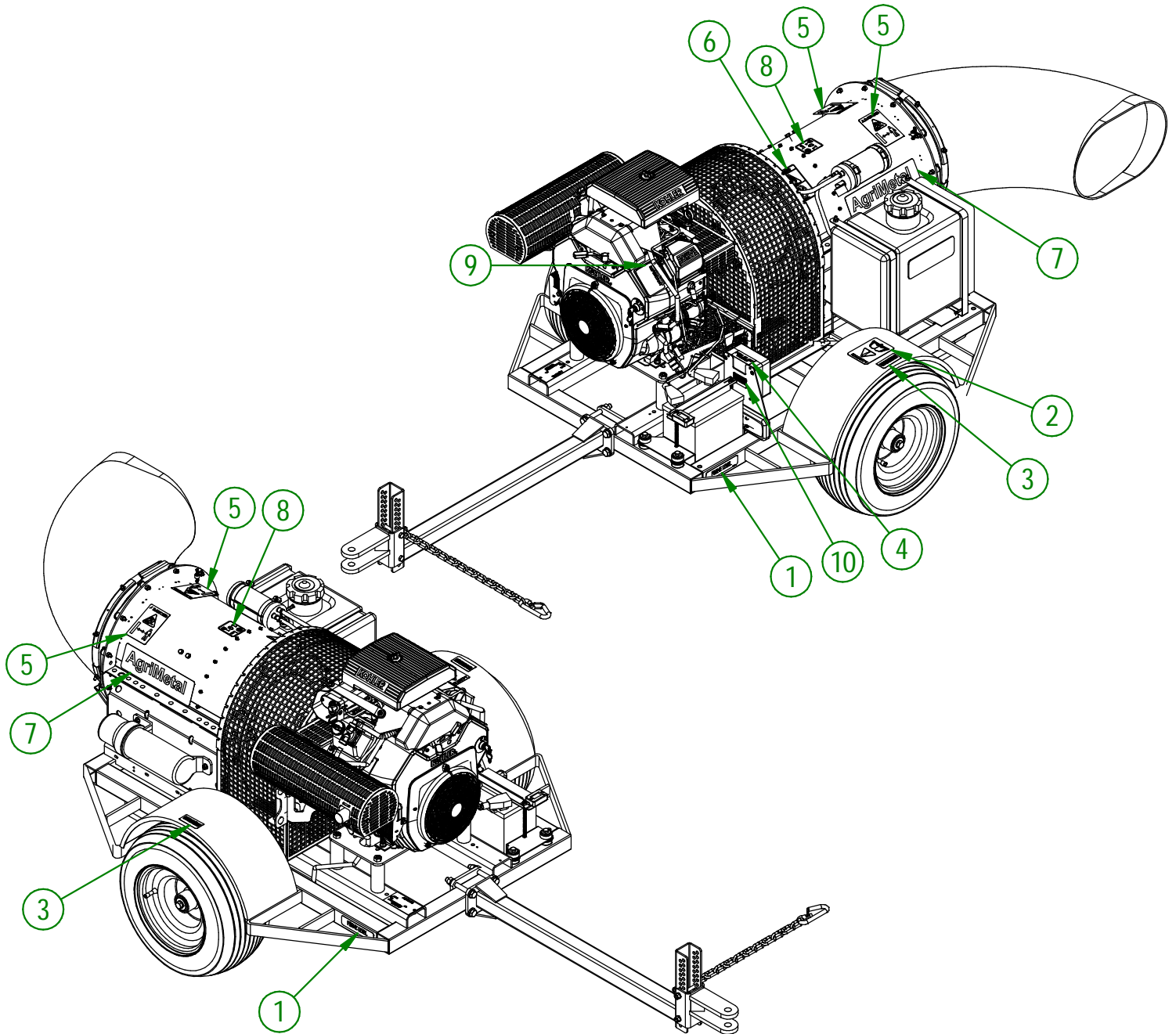
**AGRIMETAL****TURBINE BLOWER 270 CARB**

CREATION : 18/09/18  
 REVISION : 31/10/23

ASSEMBLY : **33-99-2506**  
 AUTHOR : J.KABWE