

AgriMetal

PARTS LIST

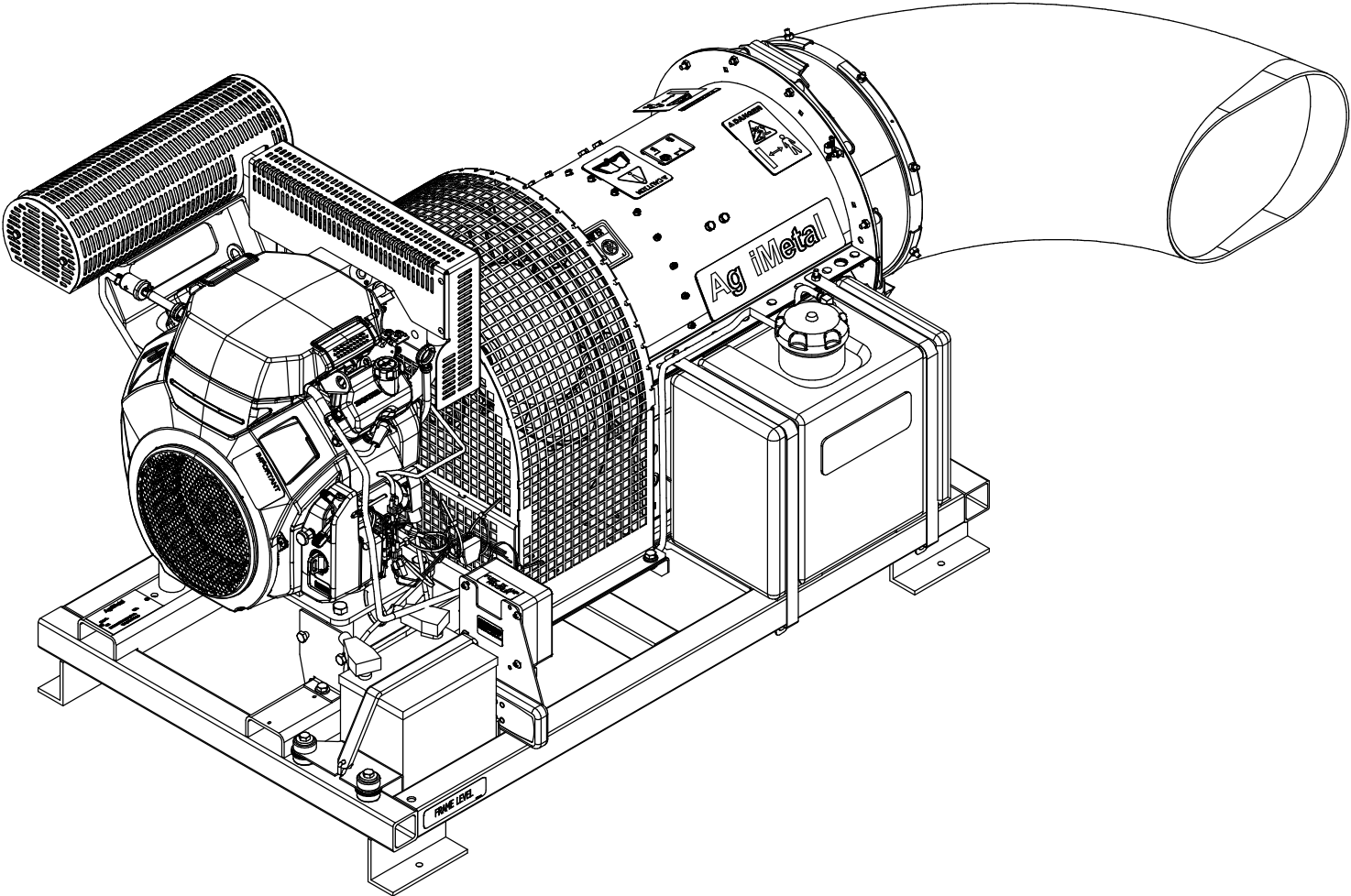

TB 240-B (WITHOUT WHEELS)

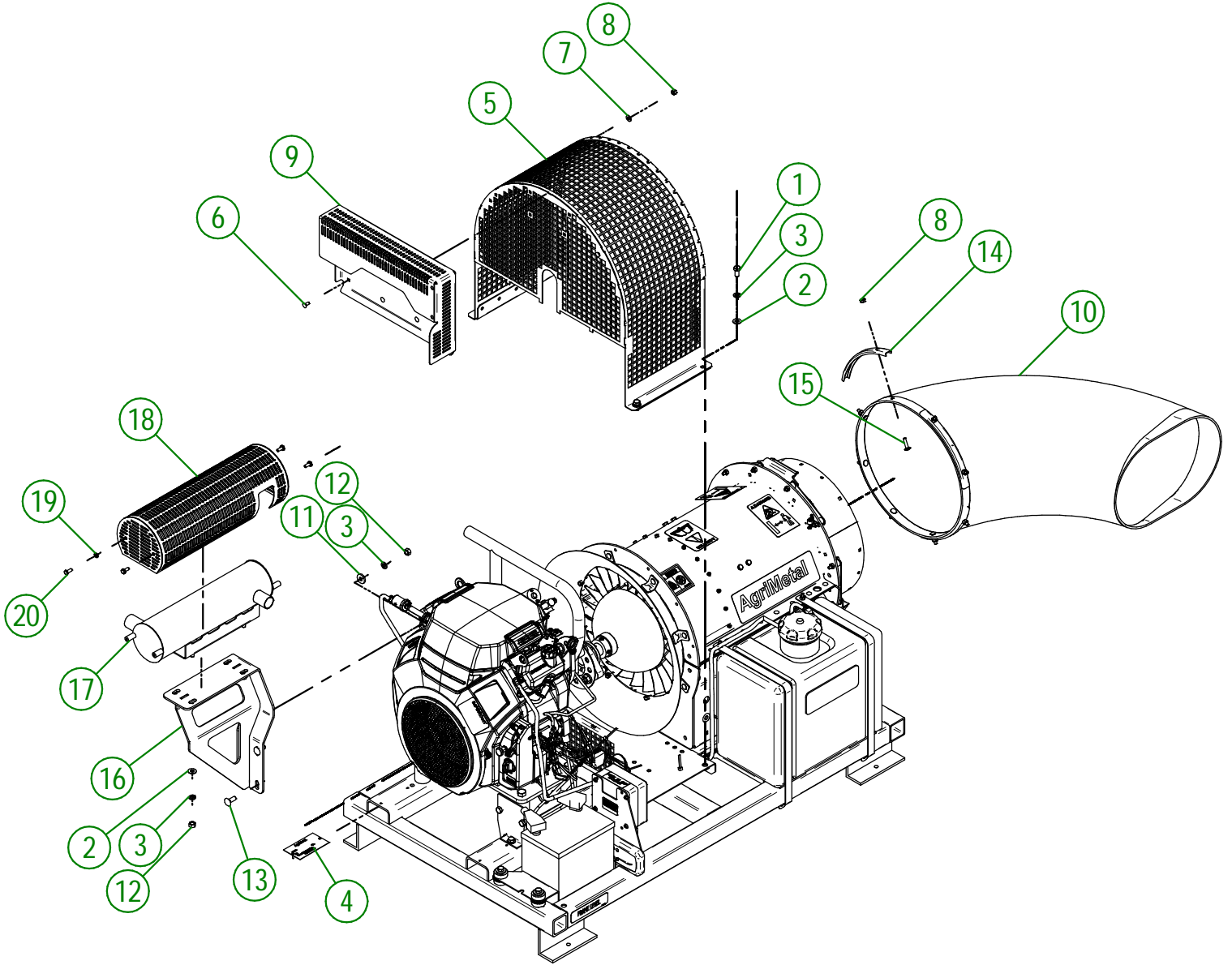

AGRIMETAL	
TURBINE BLOWER 240-B	
CREATION : 25/06/24	ASSEMBLY : 33-99-3051
REVISION : 25/06/24	AUTHOR : dessin3

33-99-3051

#	PART #	QTY	TITLE
1	NC01-17-0112	4	HEX. BOLT GR2 ZINC 3/8-16 X 3/4"
2	01-01-2485	8	FLAT WASHER 14 GA X 13/16"OD X 25/64" ID
3	NC02-32-0012	12	LOCK WASHER ZINC 3/8"
4	NC13-50-0086	1	SERIAL NUMBER PLATE
5	33-50-0035	1	TURBINE GUARD (TB-270-240)
6	NC01-04-0001	6	CARR. BOLT GR2 ZINC 1/4-20 X 1/2"
7	NC02-22-0008	6	WASHER ZINC 5/16"
8	NC01-96-0009	14	NYLON-INSERT LOCKNUT ZINC 1/4-20
9	33-55-1560	1	EXHAUST GUARD
10	33-42-0005	1	90° PLASTIC ELBOW
11	21-01-0950	4	FLAT WASHER 10GA 1.005" DIA X 25/64"
12	NC02-07-0018	8	HEX. NUT ZINC 3/8-16
13	NC01-04-0109	4	CARR. BOLT GR2 ZINC 3/8-16 X 1"
14	33-01-2480	4	DUCT CLAMP
15	NC01-04-0005	8	CARR. BOLT GR2 ZINC 1/4-20 X 1"
16	22-50-0301	1	EXHAUST SUPPORT (GX690 24HP)
17	33-50-1050	1	27 HP KOHLER MUFFLER
18	33-50-1055	1	MUFFLER GUARD (27 HP KOHLER)
19	NC02-32-0010	4	LOCK WASHER ZINC 1/4"
20	NC01-29-0003	4	HEX. BOLT GR5 ZINC 1/4-28 X 5/8"

#	PART #	QTY	TITLE
1	NCI3-25-0369	1	ELECTRIC BOX TB 270
2	NC02-42-0096	4	PHILLIPS SCREW ZINC #14 X 5/8"
3	NCI3-15-0055	1	INSULATING ROLLED COLLAR 7/16"ID X 15/16"OD X 5/16"T
4	NCI3-25-0019	10	BLACK TIE RAP
5	33-22-2240	1	WIRE PROTECTOR
6	NCI3-25-0374	1	WIRE 46"(NEW BOX)
7	33-55-0045	1	DEFLECTOR ELECTRIC MOTOR
8	33-57-0076	1	REMOTE CONTROL GROUP.

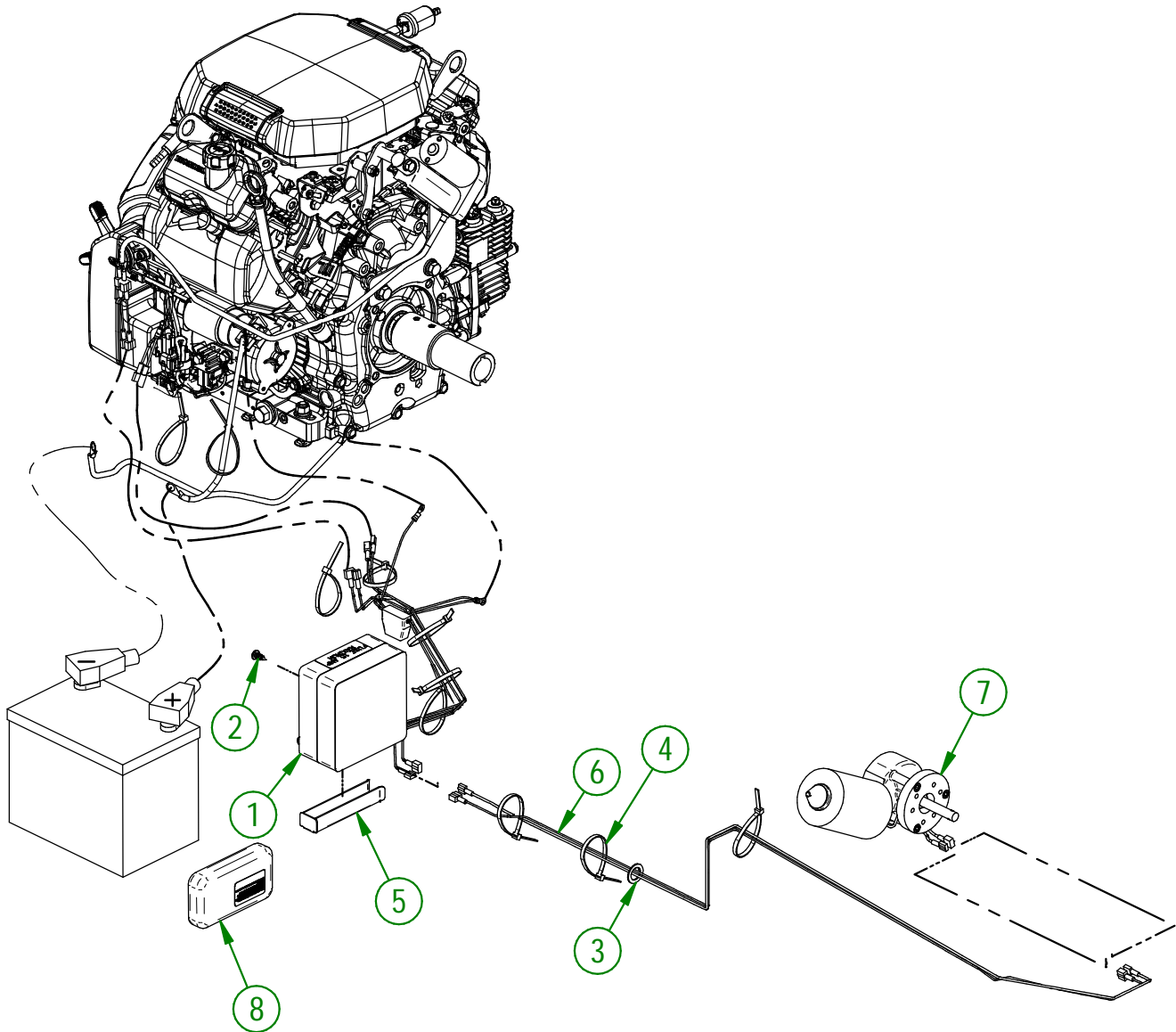

AGRIMETAL	
TURBINE BLOWER 240 CARB	
CREATION : 25/06/24	ASSEMBLY : 33-99-3051
REVISION : 25/06/24	AUTHOR : D. CHASSÉ

TB 240

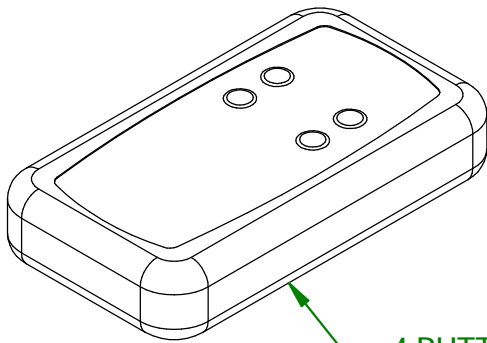
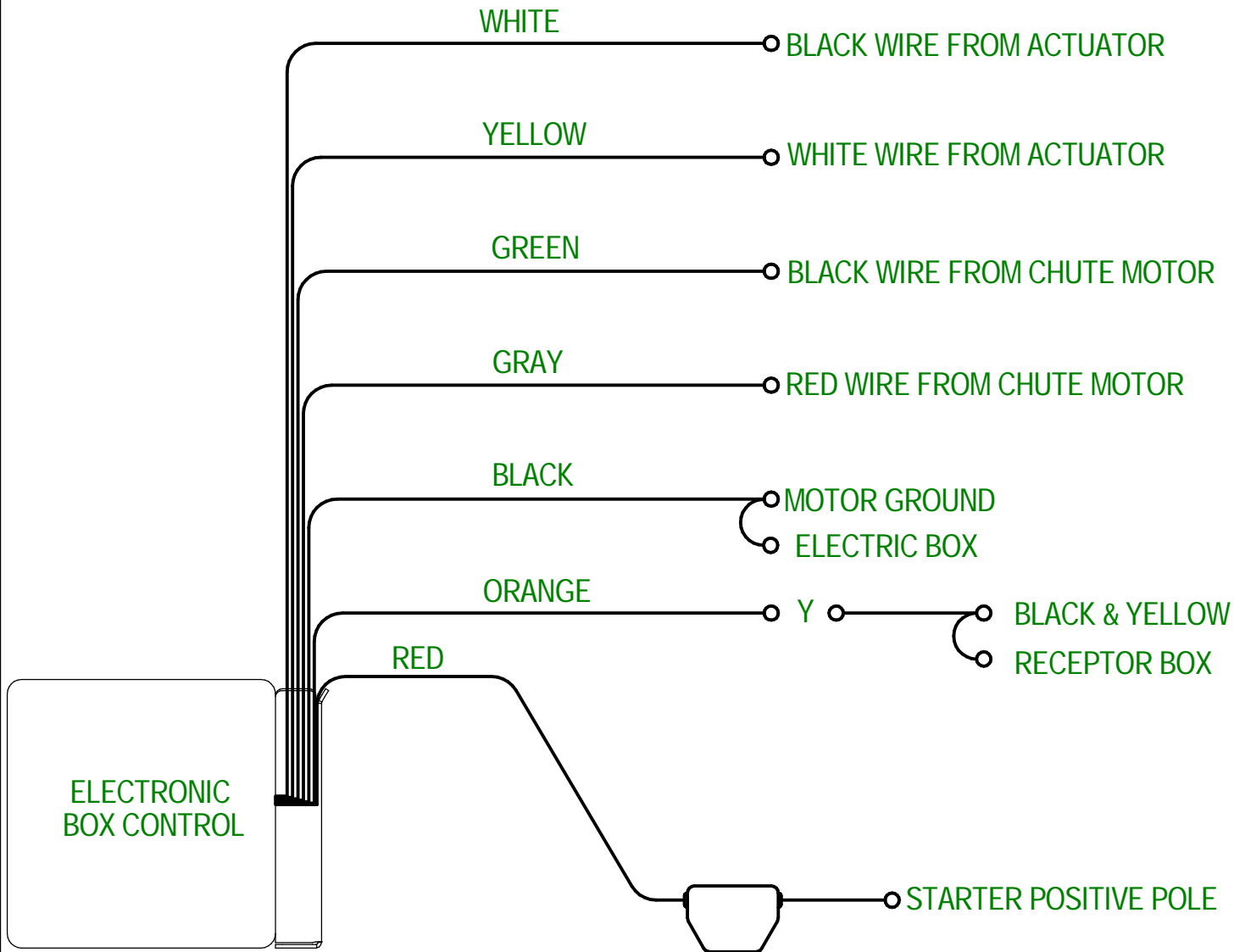

4 BUTTONS REMOTE CONTROL

AGRIMETAL	
ELECTRONIC BOX CONTROL GROUP.	
CREATION : 12/02/24	ASSEMBLY : 33-57-0006
REVISION : 16/02/24	AUTHOR : J.KABWE

#	PART #	Qty	TITLE
1	33-01-3045	2	GAS TANK STRAP
2	33-13-0015	1	GAZ LINE WEIGH
3	33-46-0035	1	1/4" GAZ LINE X 12" LG
4	33-46-0590	1	GAS VENT HOSE 1/2" DIA.X 1/4" D.I. X 64"
5	33-46-0661	1	GAS HOSE 1/2" DIA.X 1/4" D.I. X 70"
6	NC01-04-0002	4	CARR. BOLT GR2 ZINC 1/4-20 X 5/8"
7	NC01-65-0201	2	SPRING -GRIP HOSE CLAMPS 1/2" O.D
8	NC01-96-0009	4	NYLON-INSERT LOCKNUT ZINC 1/4-20
9	NC13-25-0019	3	BLACK TIE RAP
10	NC13-80-0247	1	GAS CAP
11	NC13-80-0321	1	GAS TANK
12	NC13-80-0323	1	90° ELBOW X 1/4" GAS LINE
13	NC13-80-0324	1	GROMMET VITRON

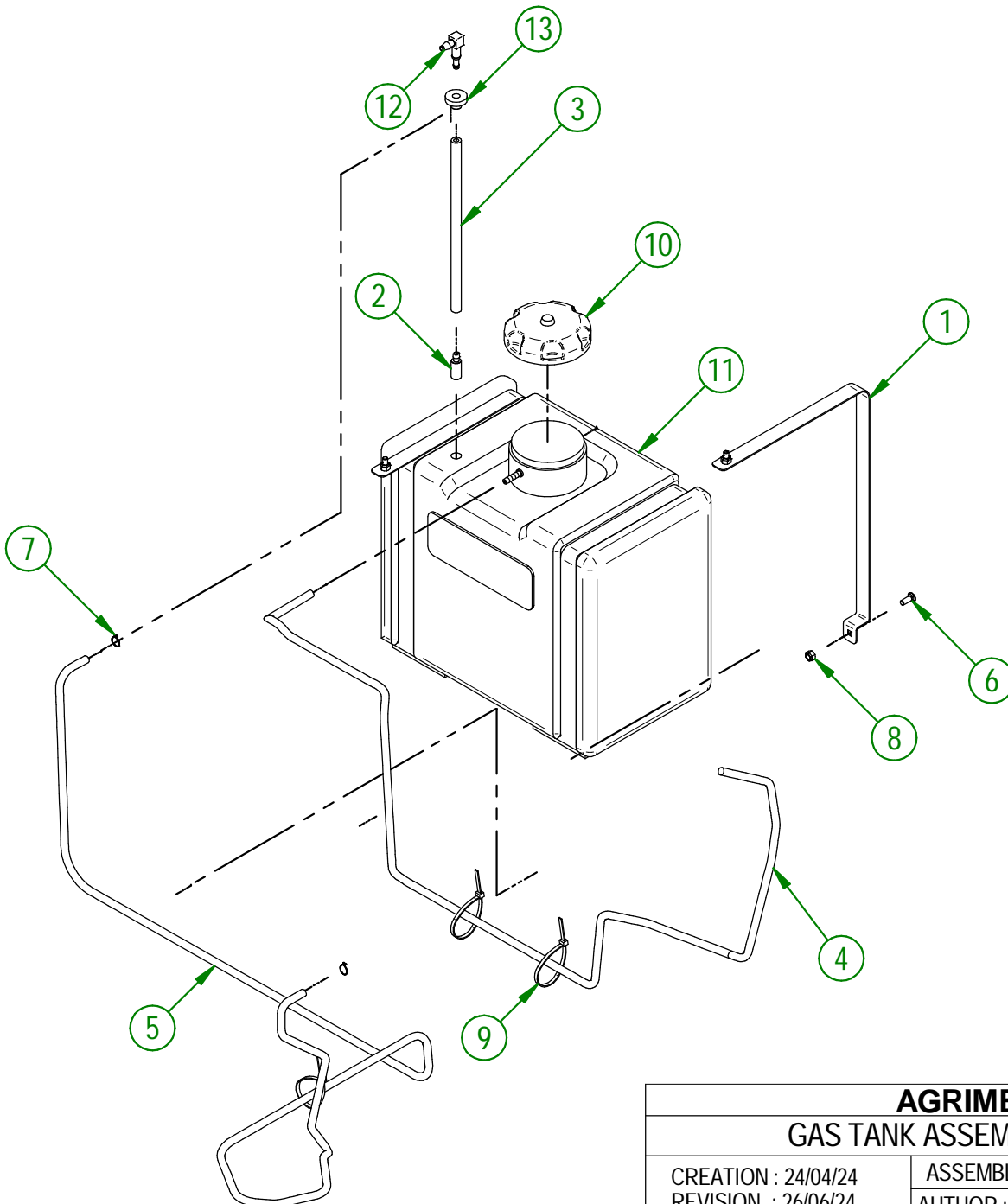

AGRIMETAL	
GAS TANK ASSEMBLY (TB240)	
CREATION : 24/04/24	ASSEMBLY : 33-57-0134
REVISION : 26/06/24	AUTHOR : D. CHASSÉ

33-57-2515

#	PART #	Qty	TITLE
1	33-57-2505	1	ASSEMBLY FRAME STICKER INCLUDED
2	33-01-0085	1	HONDA BOX BRACKET
3	NC01-24-0007	2	HEX. BOLT GR5 BLACK 3/8-16 X 3/4"
4	NC02-25-0009	1	WASHER 0.406" I.D. X 0.815 O.D.
5	NC01-25-0114	1	HEX. BOLT GR2 ZINC 3/8-16 X 1"
6	NC01-37-0267	4	HEX. BOLT GR8 ZINC 1/2-20 X 6" LG
7	NC01-96-0009	2	NYLON-INSERT LOCKNUT ZINC 1/4-20
8	NC02-32-0012	1	LOCK WASHER ZINC 3/8"
9	NC02-22-0012	4	WASHER ZINC 1/2 BOLT = 9/16"Ø X 1 3/8" OD
10	NC01-94-0013	4	NYLON NUT ZINC 1/2-20"
11	NC01-93-0011	1	LOCK NUT 3/8-16
12	33-57-0210	1	ENGINE BASE GROUP

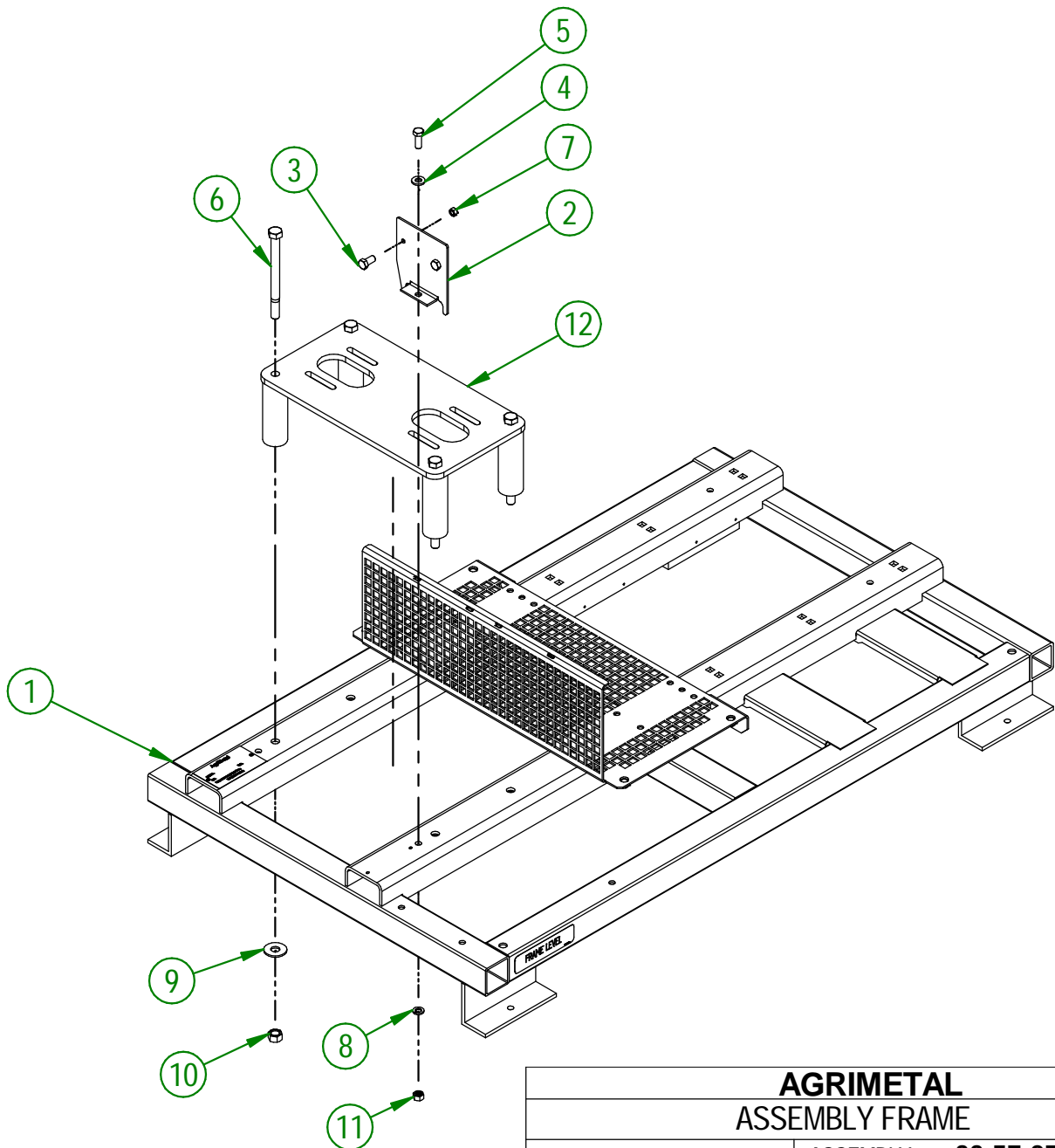

AGRIMETAL	
ASSEMBLY FRAME	
CREATION : 10/05/23	ASSEMBLY : 33-57-2515
REVISION : 29/11/23	AUTHOR : D. CHASSÉ

33-57-2548

#	PART #	Qty	TITLE
1	01-01-2485	4	FLAT WASHER 14 GA X 13/16"OD X 25/64" ID
2	33-03-1005	4	ENGINE SHIM
3	33-22-5600	8	ENGINE STOPPER
4	NC01-07-0110	4	CARR. BOLT GR5 ZINC 3/8-16 X 1 1/4"
5	NC01-07-0113	4	CARR. BOLT GR5 ZINC 3/8-16 X 2" LG
6	NC02-07-0018	8	HEX. NUT ZINC 3/8-16
7	NC02-32-0012	8	LOCK WASHER ZINC 3/8"

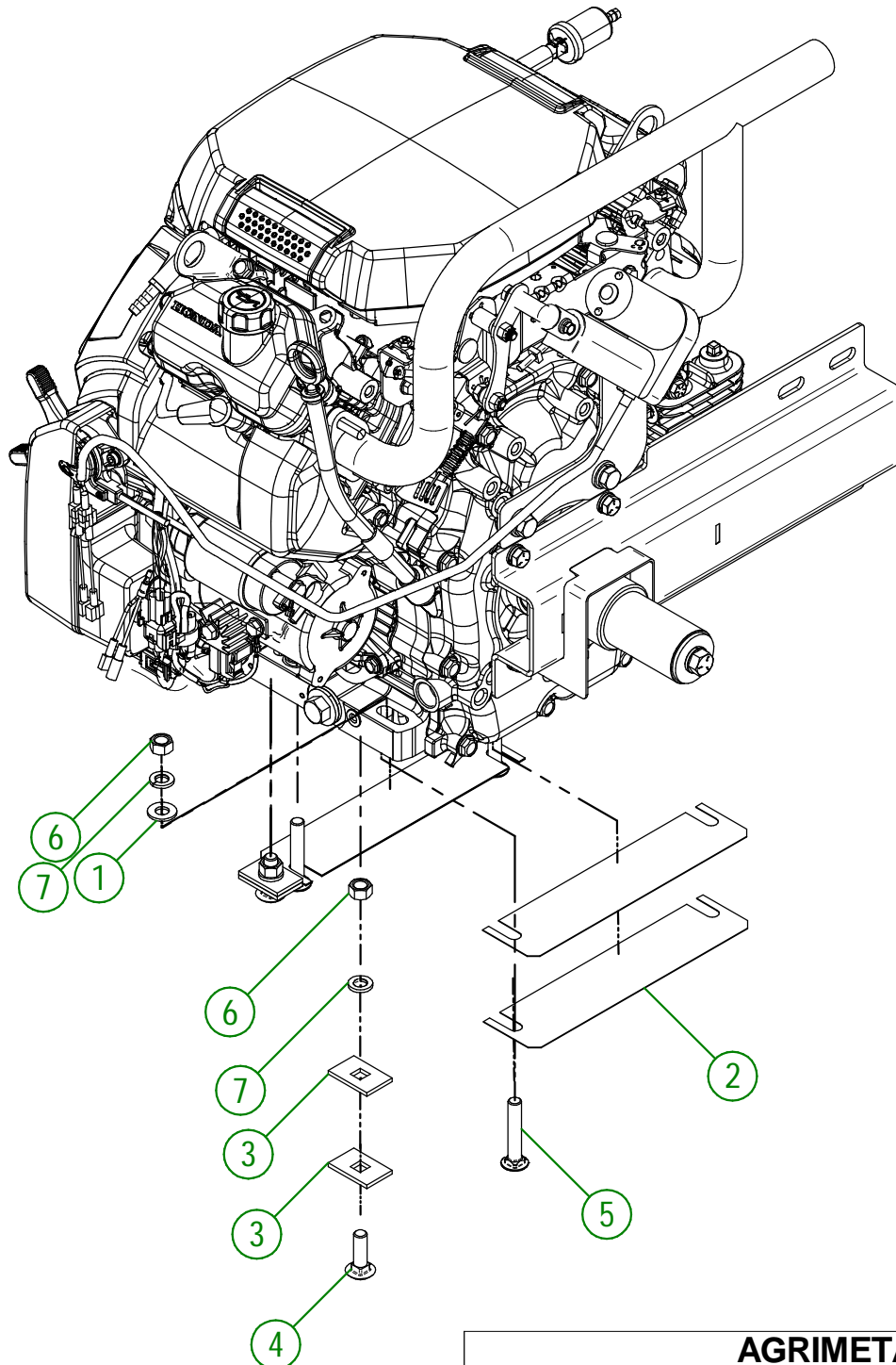

AGRIMETAL	
COMPLETE HONDA ENGINE WITH PARTS	
CREATION : 18/06/24	ASSEMBLY : 33-57-2548
REVISION : 18/06/24	AUTHOR : D. CHASSÉ

#	PART #	Qty	TITLE
1	33-04-1600	2	FLANGE
2	33-21-0055	4	SLEEVE
3	01-01-0925	4	WASHER
4	33-01-7570	2	WASHER
5	NC14-62-0016	1	QD BUSHING SH I 1/4"
6	NC14-62-0233	1	QD BUSHING SH I 5/8"
7	33-20-0152	2	SPACER
8	NC01-37-0253	4	HEX. BOLT GR8 ZINC 1/2-20 X 2 1/2"
9	NC01-94-0013	4	NYLON NUT ZINC 1/2-20"
10	33-41-0920	1	SQUARE KEY

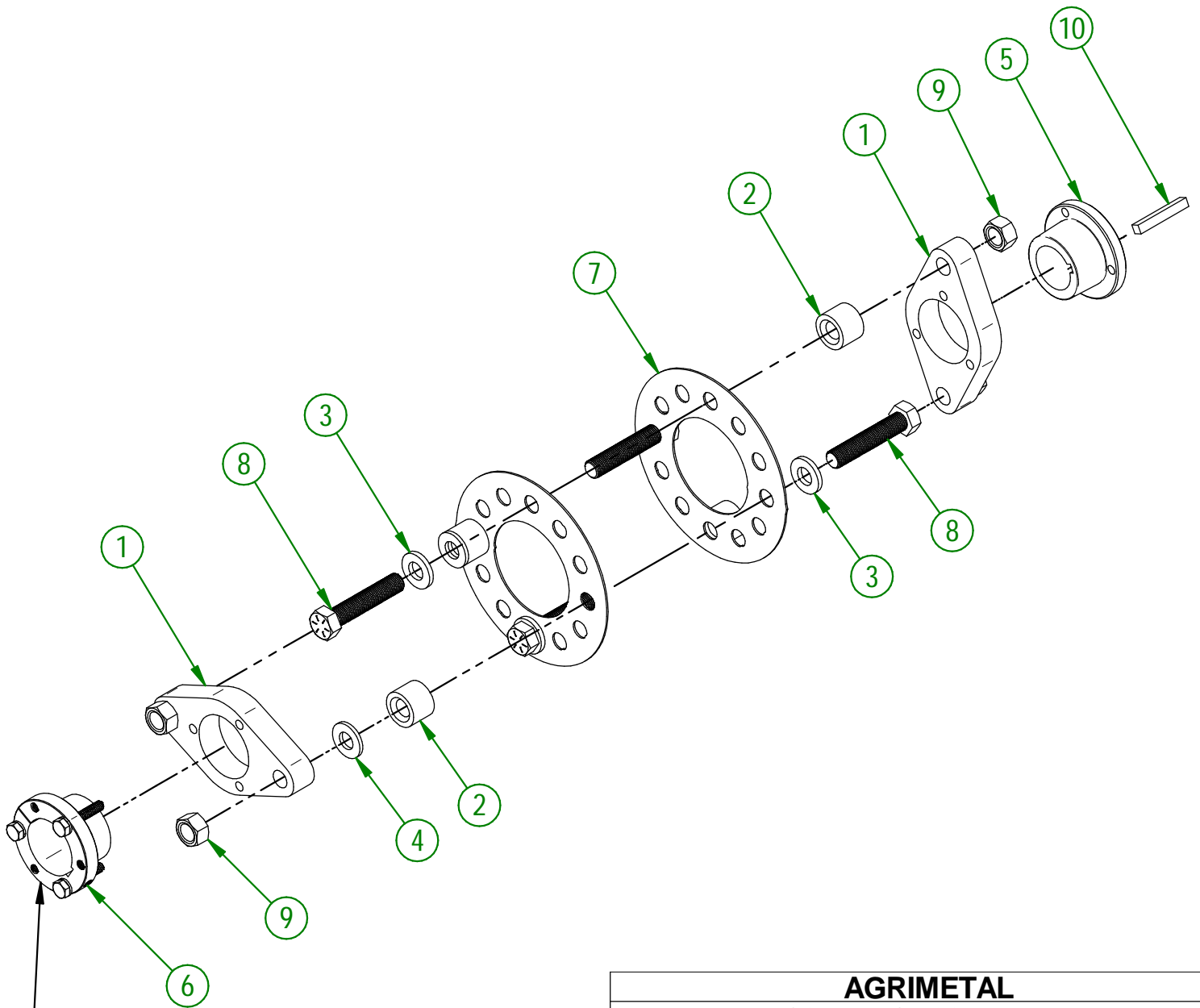

ENGINE SIDE

AGRIMETAL	
COUPLING ASSEMBLY	
CREATION : 20/09/22	ASSEMBLY : 33-57-0047
REVISION : 08/11/23	AUTHOR : D. CHASSÉ

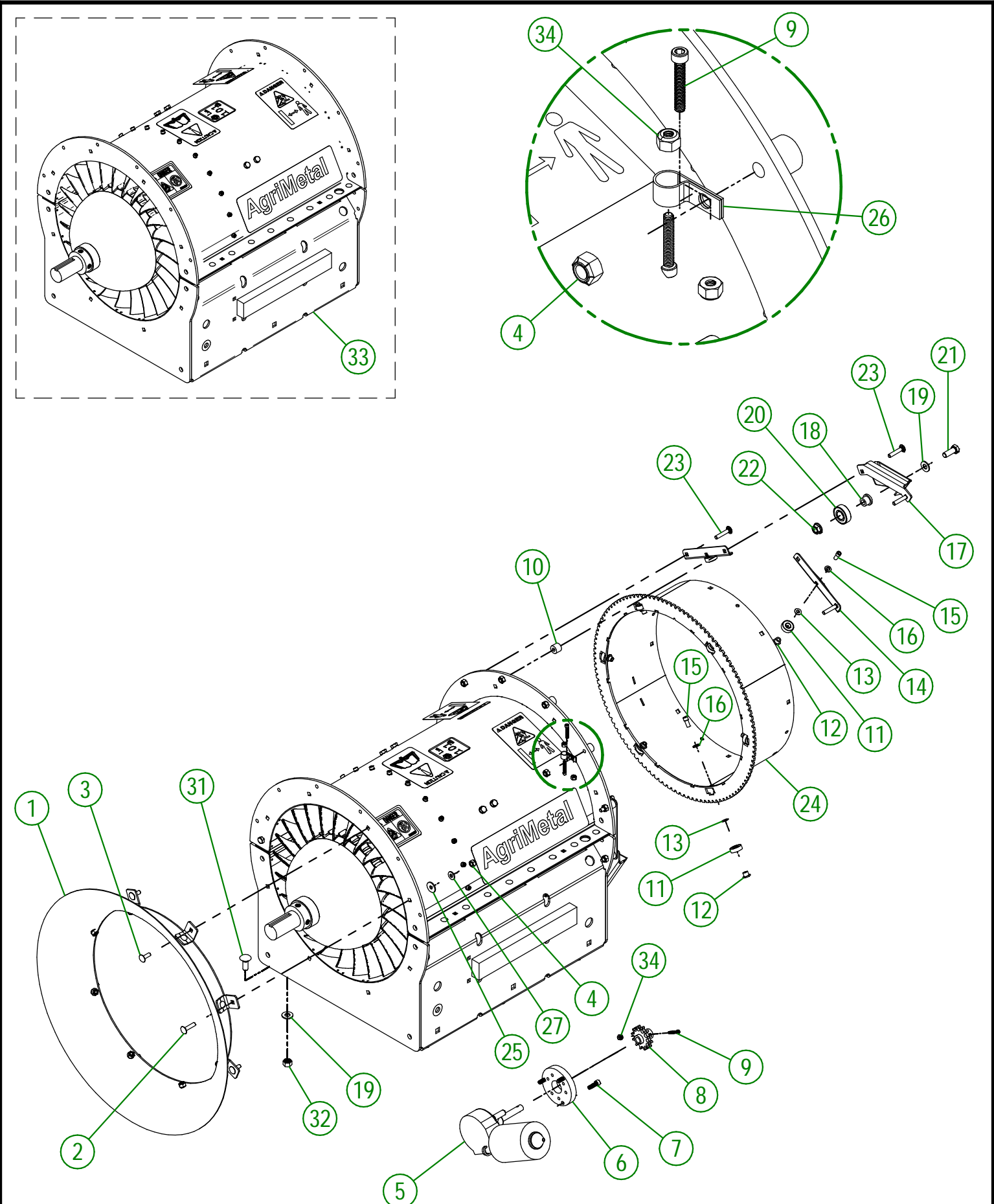

AGRIMETAL	
REGROUP. TURBINE BLOWER	
CREATION : 25/06/24	ASSEMBLY : 33-57-0021
REVISION : 09/10/24	AUTHOR : J.KABWE

33-57-0021

#	PART #	QTY	TITLE
1	33-55-0085	1	AIR INTAKE ASSY.
2	NC01-04-0005	2	CARR. BOLT GR2 ZINC 1/4-20 X 1"
3	NC01-04-0003	6	CARR. BOLT GR2 ZINC 1/4-20 X 3/4"
4	NC01-96-0009	21	NYLON-INSERT LOCKNUT ZINC 1/4-20
5	33-35-0005	1	OUTLET MOTOR
6	33-21-0100	1	ENGINE CONVERSION PLATE
7	NC02-50-1072	3	SOCKET CAP SCREW M6 X 20mm
8	33-55-0035	1	GEARED CROWN SPROCKET
9	NC02-50-0069	3	SOCKET CAP SCREW T.RON 8-32 X 1"
10	33-21-0080	12	SPACER
11	NC14-75-0153	12	BALL BEARING R6 2RS 3/8" X 7/8" X 0.281"
12	33-25-2410	12	BEARING BUSHING
13	33-03-4605	12	BEARING SHIM 1/4" ALUMINUM
14	33-01-2425	6	BEARING HOLDER BRACKET
15	NC02-51-0578	12	SOCKET CAP SCREW T.RON. NF 1/4-28 X 1/2 STAINLESS
16	NC02-32-0010	12	LOCK WASHER ZINC 1/4"
17	33-50-0555	3	WELD ASSEMBLY BEARING SUPPORT
18	33-21-0060	3	BEARING HOLDER
19	01-01-2485	9	FLAT WASHER 14 GA X 13/16"OD X 25/64" ID
20	NC14-75-0068	3	BALL BEARING 99502H
21	NC01-17-0114	3	HEX. BOLT GR2 ZINC 3/8-16 X 1"
22	NC02-14-0019	3	FLANGE NUT HEX. NC 3/8-16 GR. B
23	NC01-04-0006	12	CARR. BOLT GR2 ZINC 1/4-20 X 1 1/4"
24	33-50-0018	1	DUCT COLECTOR
25	36-01-2430	3	FLAT WASHER 14GA X 17/64" I.D. X 13/16" O.D.
26	NC13-25-0233	1	VINYLE PROTECTOR COLLAR
27	NC02-25-0007	2	WASHER ZINC 0.281 = 9/32
28	33-20-0065	1	conical sleeve
29	NC02-32-0012	1	LOCK WASHER ZINC 3/8"
30	NC01-25-0118	1	HEX. BOLT GR5 NC ZINC 3/8-16 X 2"
31	NC01-04-0109	6	CARR. BOLT GR2 ZINC 3/8-16 X 1"
32	NC01-93-0011	6	LOCK NUT 3/8-16
33	33-57-0082	1	TURBINE KIT (NEW)
34	NC01-96-0004	3	8-32 JAM NUT

#	PART #	Qty	TITLE
1	NC01-04-0056	2	CARR. BOLT 5/16-18 X3/4"
2	NC02-32-0011	2	LOCK WASHER ZINC 5/16"
3	NCI3-12-0017	1	12 VOLTS GEL BATTERY
4	NC02-07-0017	2	HEX. NUT 5/16-18
5	NCI3-80-0267	1	RED PROTECTOR FOR BATTERY POST
6	NCI3-80-0268	1	BLACK PROTECTOR FOR BATTERY POST
7	33-57-2401	1	BATTERY SUPPORT PLATE "INCL. STICKER"
8	NCI3-15-0354	3	RED RUBBER BASE MOUNT
9	26-03-4800	9	WASHER
10	21-01-0950	3	FLAT WASHER 10GA 1.005" DIA X 25/64"
11	NC01-25-0126	3	HEX. BOLT GR5 ZINC 3/8-16 X 4"
12	NC02-25-0009	3	WASHER 0.406" I.D. X 0.815 O.D.
13	NC02-32-0012	3	LOCK WASHER ZINC 3/8"
14	NC02-07-0018	3	HEX. NUT ZINC 3/8-16
15	33-42-0130	2	BLACK ADHESIVE-BACK STRIP
16	NCI3-15-0008	1	RUBBER STRAP
17	33-42-0135	2	BLACK ADHESIVE-BACK STRIP

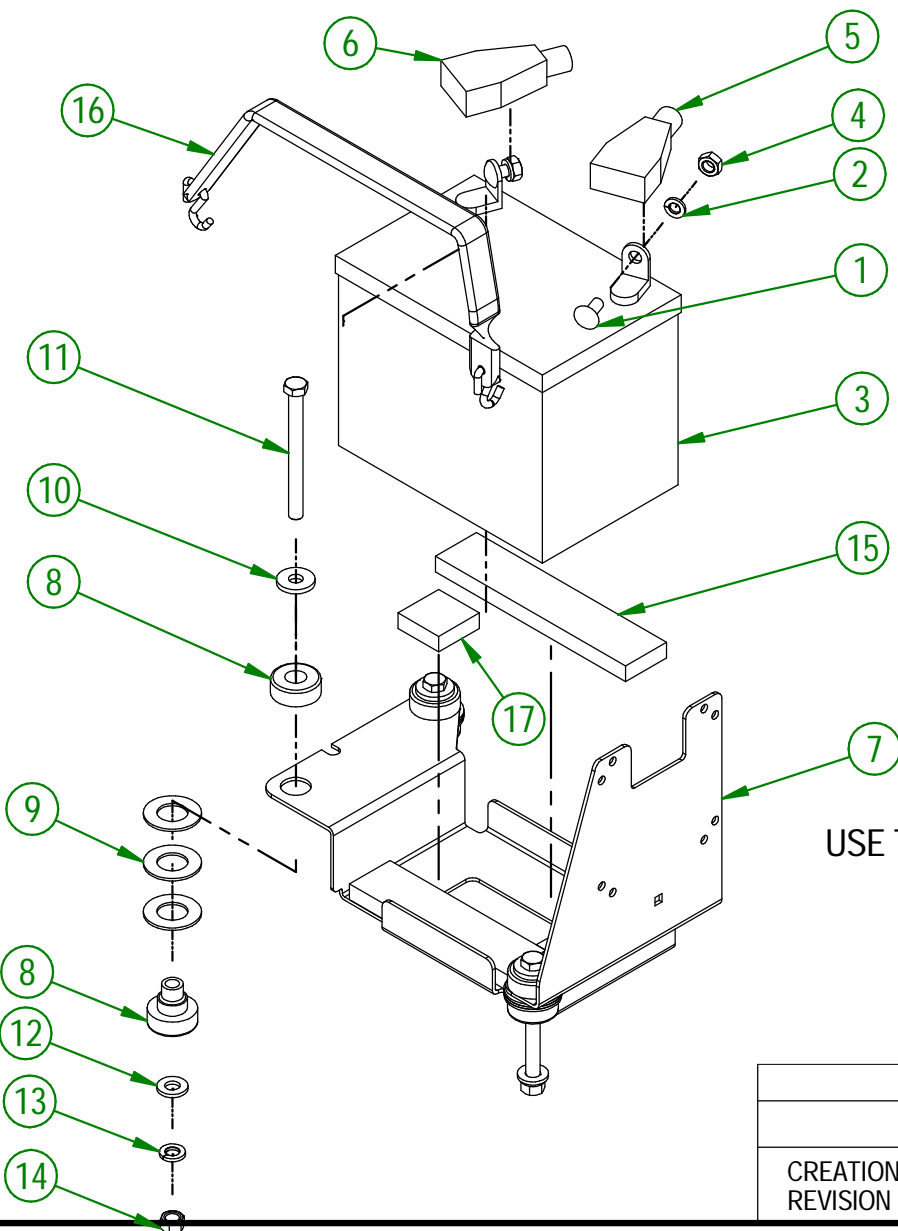

USE THESE PIECES ONLY IF YOUR SERIAL NUMBER IS AFFECTED:

#45503 AND ABOVE

AGRIMETAL	
12 VOLTS BATTERY GROUP.	
CREATION : 21/02/24	ASSEMBLY : 33-57-0059
REVISION : 05/07/24	AUTHOR : D. CHASSÉ

33-57-2567

#	PART #	Qty	TITLE
1	NC13-30-0237	1	PLASTIC TUBE FOR OPERATOR'S MANUAL
2	NC01-04-0003	3	CARR. BOLT GR2 ZINC 1/4-20 X 3/4"
3	NC02-25-0007	3	WASHER ZINC 0.281 = 9/32
4	NC01-96-0009	3	NYLON-INSERT LOCKNUT ZINC 1/4-20
5	33-98-0626	1	OPERATION MANUAL TB 240

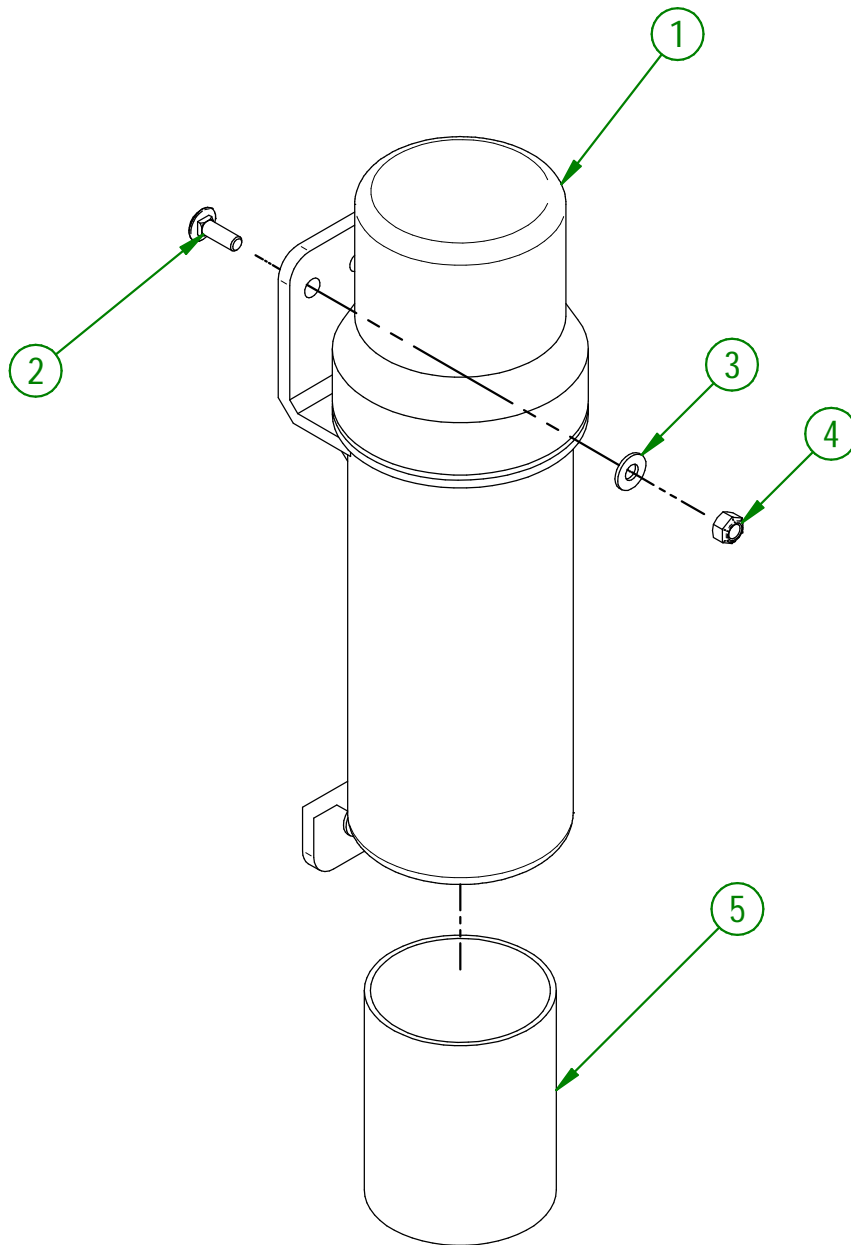

AGRIMETAL	
OPERATOR MANUEL TUBE ASSEMBLY	
CREATION : 20/06/24	ASSEMBLY : 33-57-2567
REVISION : 20/06/24	AUTHOR : D. CHASSÉ

#	PART #	QTY	TITLE
1	NCI3-33-0052	2	STICKER FRAME LEVEL
2	NCI3-33-0227	1	STICKER FUSE 15 AMP MAXIMUM
3	NCI3-33-0192	2	STICKER (PROJECTION RISK)
4	NCI3-33-0185	1	STICKER PICTOGRAM (FIRE + CIGARETTE)
5	NCI3-33-0035	2	STICKER AGRIMETAL
6	NCI3-33-0183	1	STICKER CAUTION OPERATION MANUAL
7	NCI3-33-0129	1	STICKER 101 DB
8	NCI3-33-0178	1	STICKER IMPORTANT PLEASE CHECK OIL LEVEL...
9	NCI3-33-2674	2	STICKER TO PROGRAM REMOTE CONTROL

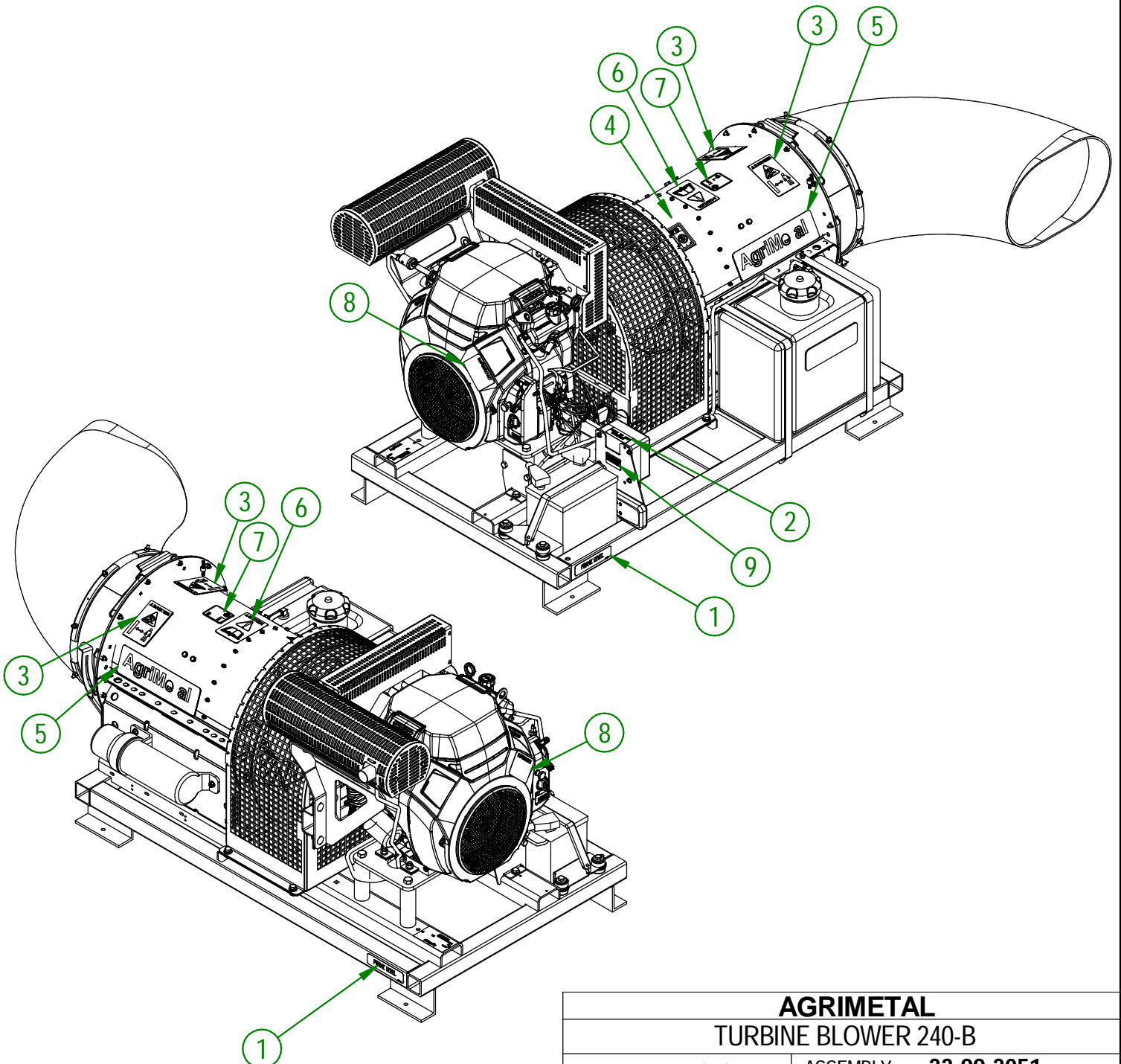

AGRIMETAL
TURBINE BLOWER 240-B

CREATION : 25/06/24
REVISION : 25/06/24

ASSEMBLY : **33-99-3051**
AUTHOR : D. CHASSÉ