

AgriMetal

PARTS LIST

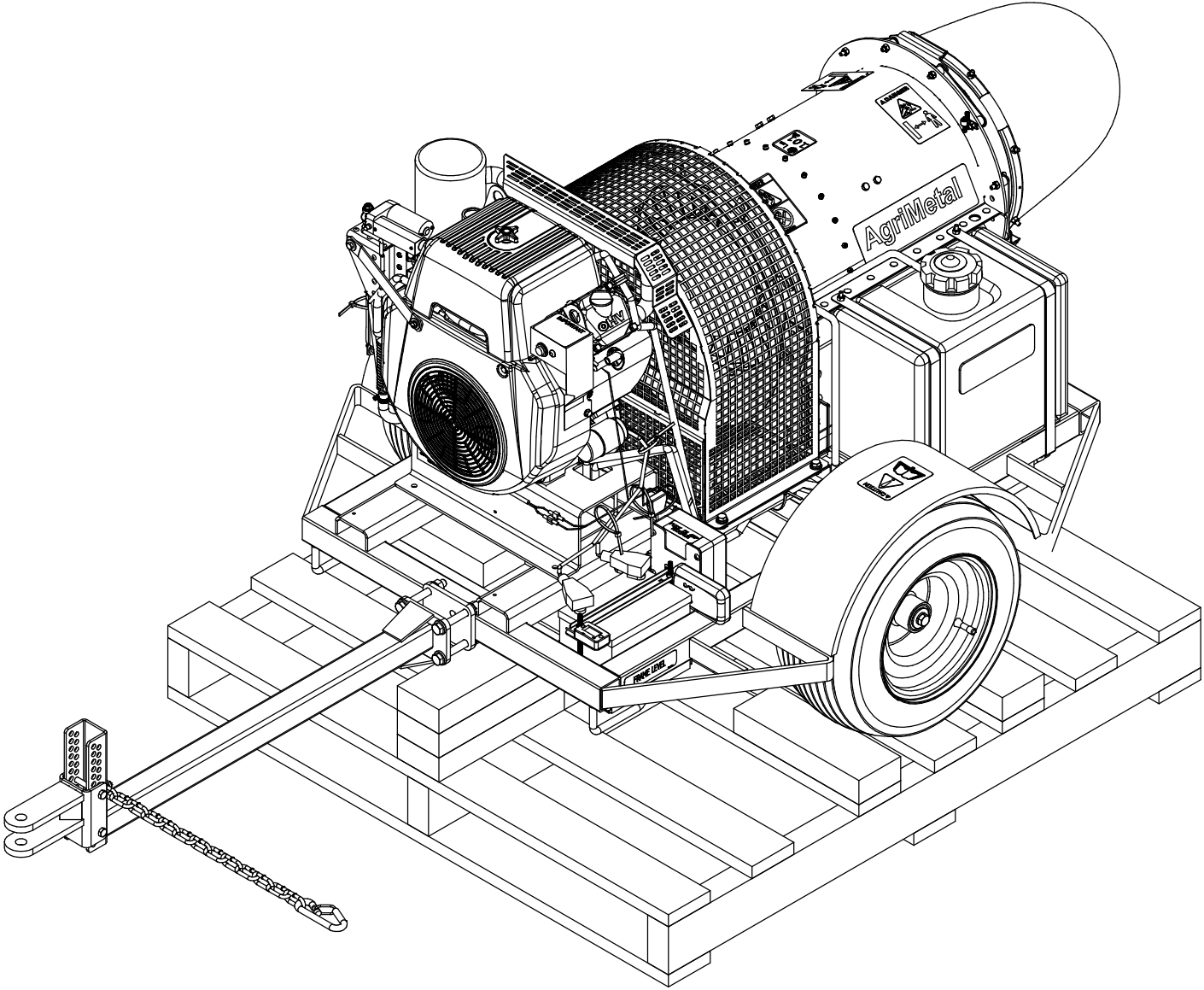

TURBINE BLOWER 280

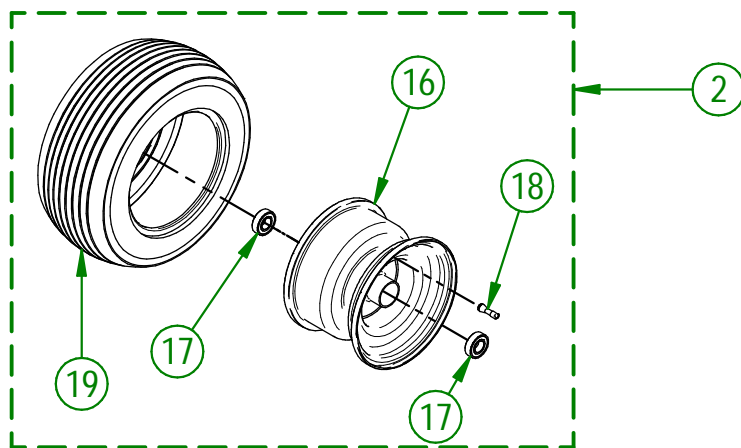
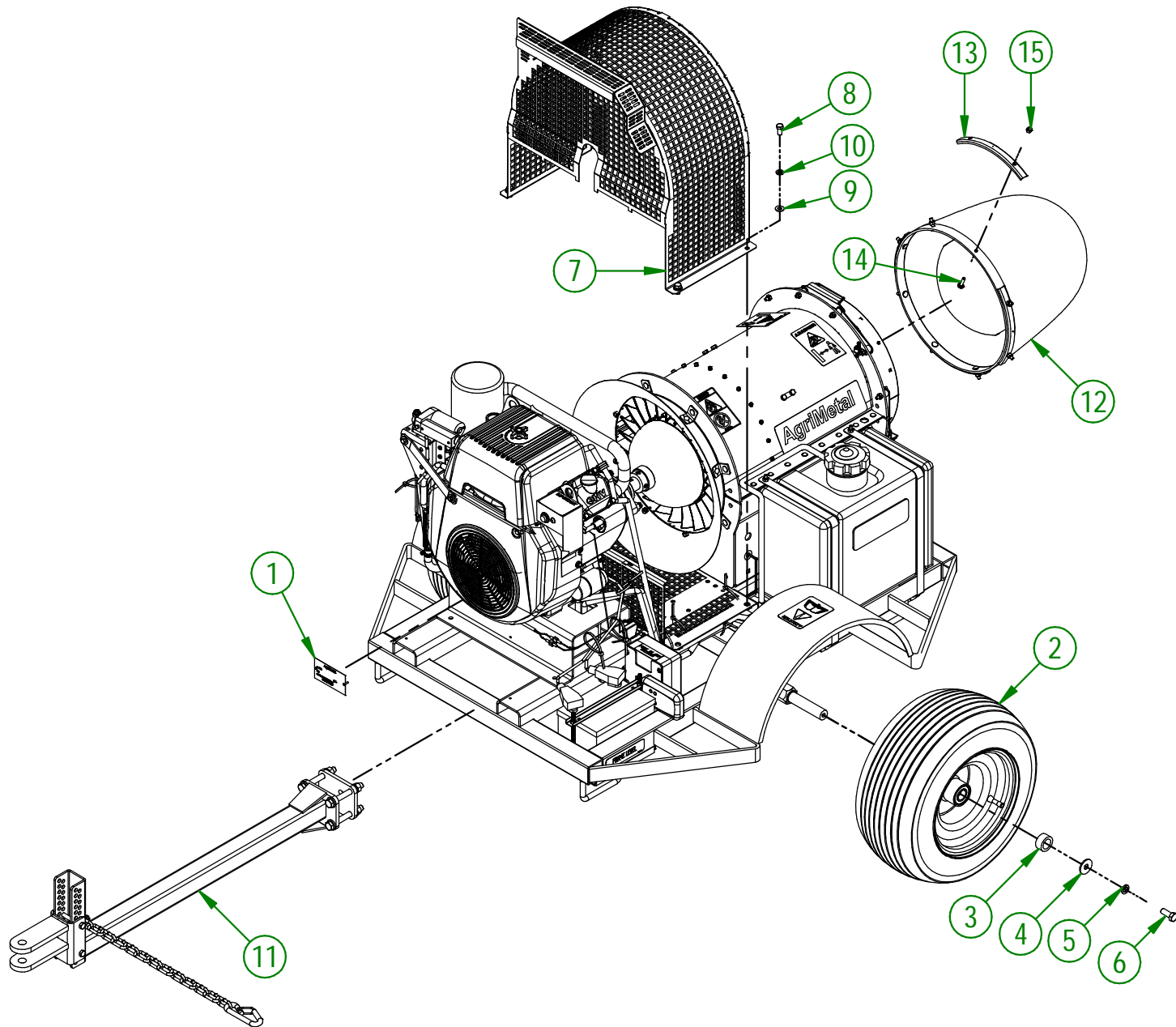

AGRIMETAL	
TURBINE BLOWER 280	
CREATION : 08/11/17	ASSEMBLY : 33-99-2500
REVISION : 01/03/22	AUTHOR : J.KABWE

33-99-2500

#	PART #	Qty	TITLE
1	25-55-0710	1	SERIAL NUMBER PLATE
2	33-55-0125	2	ASSEMBLY WHEEL 18X9.50-8 WITH BALL BEARING
3	33-21-0065	2	WHEEL BUSHING
4	01-01-1660	2	WASHER SPACER
5	NC02-32-0014	2	LOCK WASHER ZINC 1/2"
6	NC01-17-0248	2	HEX. BOLT GR2 ZINC 1/2-13 X 1 1/4"
7	33-50-2535	1	WELD ASSEMBLY GUARD
8	NC01-17-0112	4	HEX. BOLT GR2 ZINC 3/8-16 X 3/4"
9	01-01-2485	4	FLAT WASHER 14 GA X 13/16"OD X 25/64" ID
10	NC02-32-0012	4	LOCK WASHER ZINC 3/8"
11	33-55-0040	1	HITCH ASSEMBLY
12	33-42-0005	1	90° PLASTIC ELBOW
13	33-01-2480	4	DUCT CLAMP
14	NC01-04-0005	8	CARR. BOLT GR2 ZINC 1/4-20 X 1"
15	NC01-96-0009	8	NYLON-INSERT LOCKNUT ZINC 1/4-20

33-55-0125

#	PART #	Qty	TITLE
16	NC14-70-0320	1	RIM FOR NC14-70-0317
17	NC14-55-0330	2	6205-2RSI BEARING
18	NC14-70-0322	1	VALVE FOR NC14-70-0317
19	NC14-70-0319	1	WHEEL 18X9.50-8 (TURBINE)

#	PART #	Qty	TITLE
1	33-55-2550	1	GAS TANK
2	33-01-3045	2	GAS TANK STRAP
3	33-46-0528	1	GAS HOSE 1/2" DIA.X 1/4" D.I. X 50"
4	33-46-0529	1	GAS HOSE (RETURN) 1/2" DIA.X 1/4" D.I. X 48" LG
5	NC13-65-0061	1	BARBILLON HOSE 1/4 OD X 1/4 NPT MALE
6	NC13-65-0062	1	BARBILLON HOSE 3/16 OD X 1/4 NPT FEMALE
7	NC01-04-0002	4	CARR. BOLT GR2 ZINC 1/4-20 X 5/8"
8	NC01-96-0009	4	NYLON-INSERT LOCKNUT ZINC 1/4-20
9	NC01-65-0201	6	SPRING -GRIP HOSE CLAMPS 1/2" O.D
10	NC13-25-0019	4	BLACK TIE RAP
11	33-46-3750	1	PLASTIC PROTECTION EDGE AND METAL REINFORCEMENT
12	33-46-0543	1	GAS HOSE EPA 1/2" DIA.X 1/4" D.I. X 71"

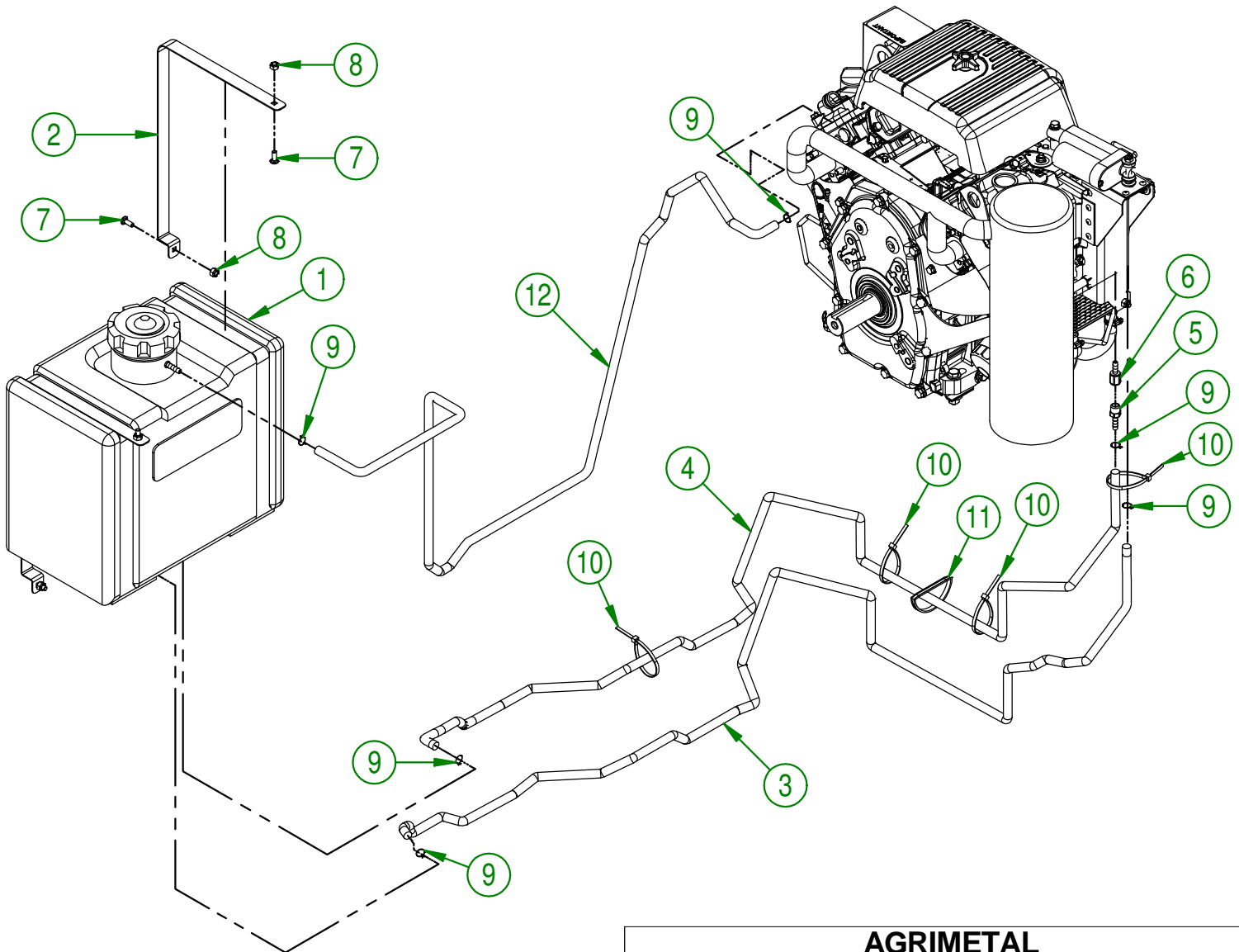

AGRIMETAL
TURBINE BLOWER 280

CREATION : 08/11/17
REVISION : 12/10/18

ASSEMBLY : **33-99-2500**
AUTHOR : J.KABWE

#	PART #	Qty	TITLE
1	NCI3-25-0369	1	ELECTRIC BOX TB 280
2	33-22-2240	1	WIRE PROTECTOR
3	NCI3-25-0374	1	WIRE 46"(NEW BOX)
4	NC02-42-0096	4	PHILLIPS SCREW ZINC #14 X 5/8"
5	NCI3-15-0055	1	INSULATING ROLLED COLLAR 7/16"ID X 15/16"OD X 5/16"T
6	NCI3-25-0019	10	BLACK TIE RAP
7	33-57-0076	1	REMOTE CONTROL GROUP.

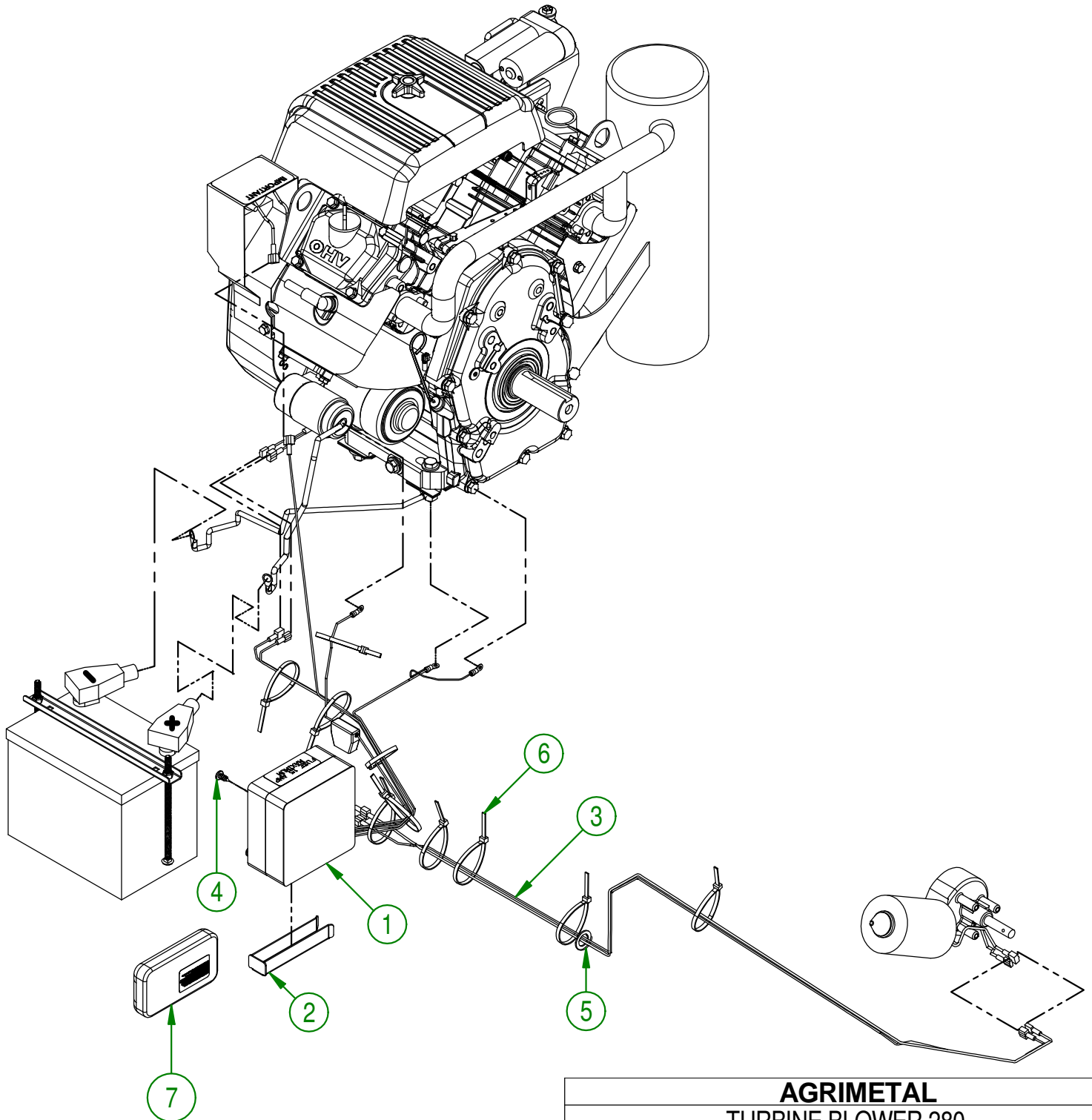

AGRIMETAL
TURBINE BLOWER 280

CREATION : 08/11/17
REVISION : 12/10/18

ASSEMBLY : **33-99-2500**
AUTHOR : J.KABWE

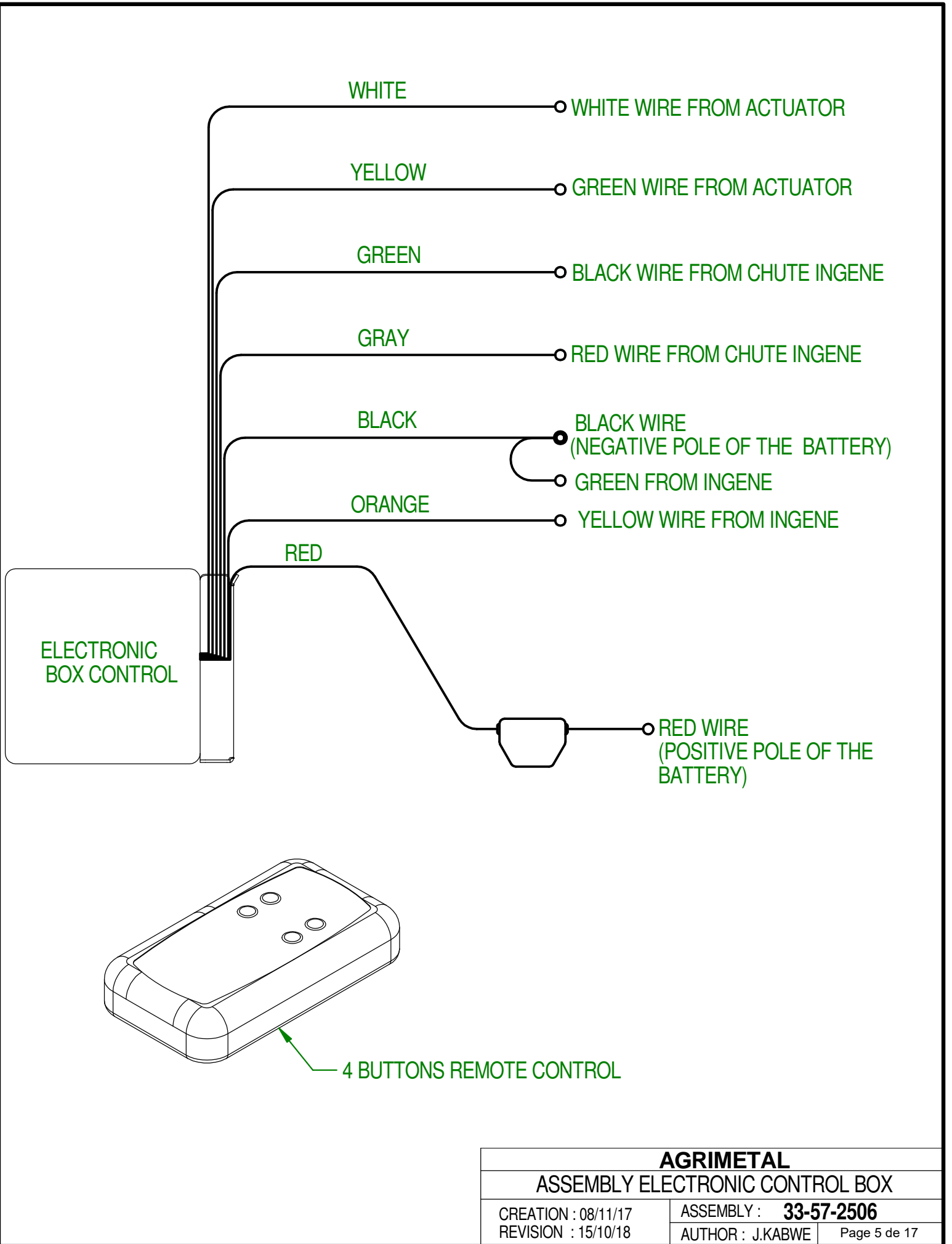

AGRIMETAL	
ASSEMBLY ELECTRONIC CONTROL BOX	
CREATION : 08/11/17	ASSEMBLY : 33-57-2506
REVISION : 15/10/18	AUTHOR : J.KABWE Page 5 de 17

33-57-2500

#	PART #	Qty	TITLE
1	33-50-2500	1	FRAME (TB-280)

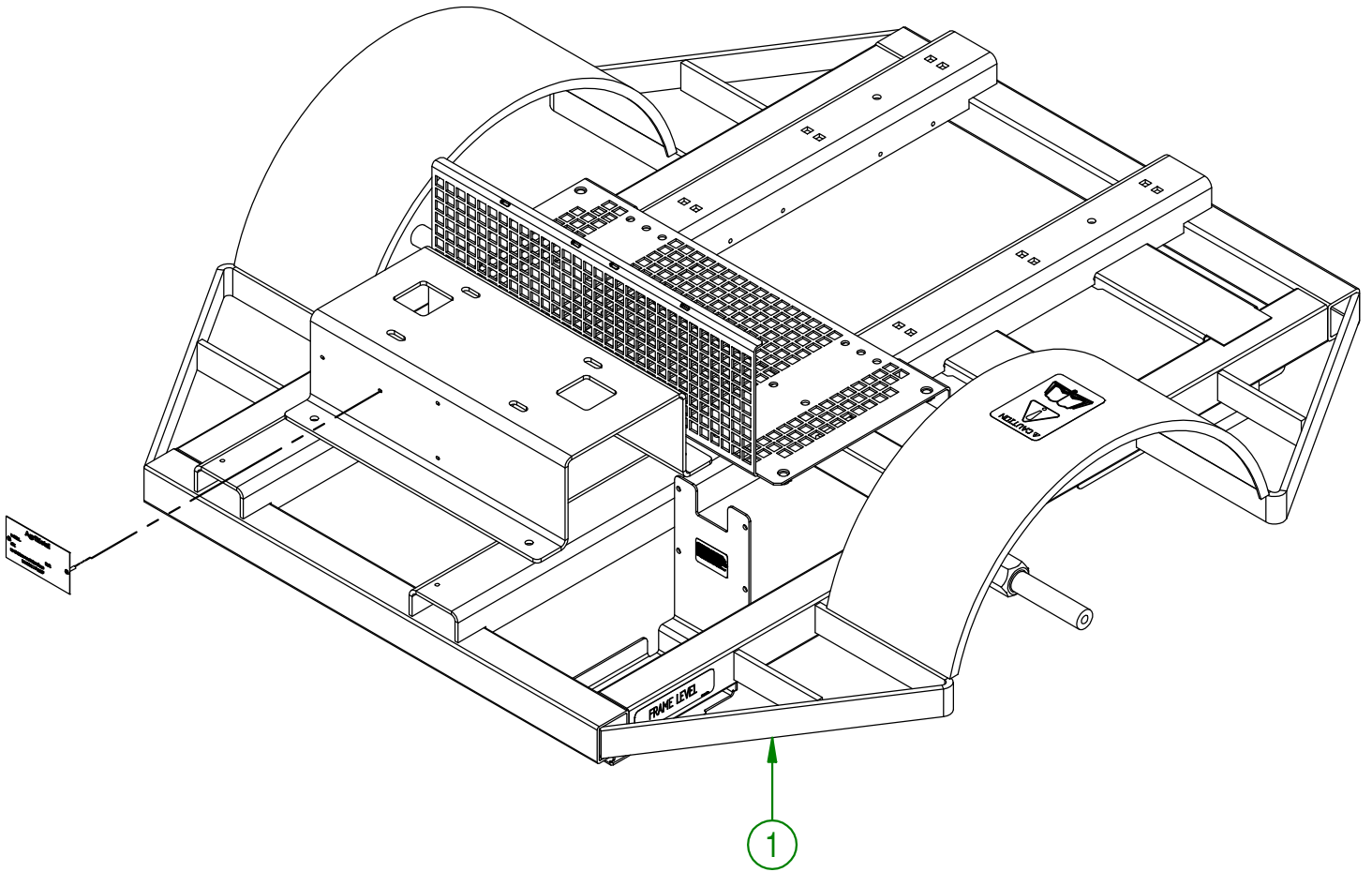

AGRIMETAL	
ASSEMBLY FRAME STICKER INCLUDED	
CREATION : 14/11/17	ASSEMBLY : 33-57-2500
REVISION : 08/01/18	AUTHOR : J.KABWE Page 6 de 17

#	PART#	QTY	TITLE
1	33-50-0010	1	DRAW BAR
2	33-04-0605	1	HITCH PLATE
3	NC01-17-0123	2	HEX. BOLT GR2 ZINC 3/8-16 X 3 1/4"
4	NC02-32-0012	2	LOCK WASHER ZINC 3/8"
5	NC02-07-0018	2	HEX. NUT ZINC 3/8-16
6	NC02-25-0011	8	WASHER SAE ZINC 17/32 ID
7	NC02-32-0014	4	LOCK WASHER ZINC 1/2"
8	NC02-07-0020	4	HEX. NUT ZINC 1/2-13
9	NC01-17-0259	4	HEX. BOLT GR2 ZINC 1/2-13 X 4"
10	NC01-17-0116	1	HEX. BOLT GR2 ZINC 3/8-16 X 1 1/2"
11	NC02-22-0010	4	WASHER 13/32" ID
12	55-41-0000	1	SAFETY CHAIN
13	NC01-96-0011	1	NYLON NUT 3/8-16
14	23-50-0045	1	HITCH HAND
15	NC13-80-0290	1	2" HITCH BALL COUPLER
16	NC02-25-0011	2	WASHER SAE ZINC 17/32 ID
17	NC01-93-0014	2	LOCK NUT ZINC 1/2-13
18	NC01-25-0257	2	HEX. BOLT GR5 ZINC 1/2-13 X 3 1/2"
19	23-09-0100	1	HITCH SPACER
20	NC02-22-0012	2	WASHER ZINC 1/2 BOLT = 9/16"Ø X 1 3/8" OD

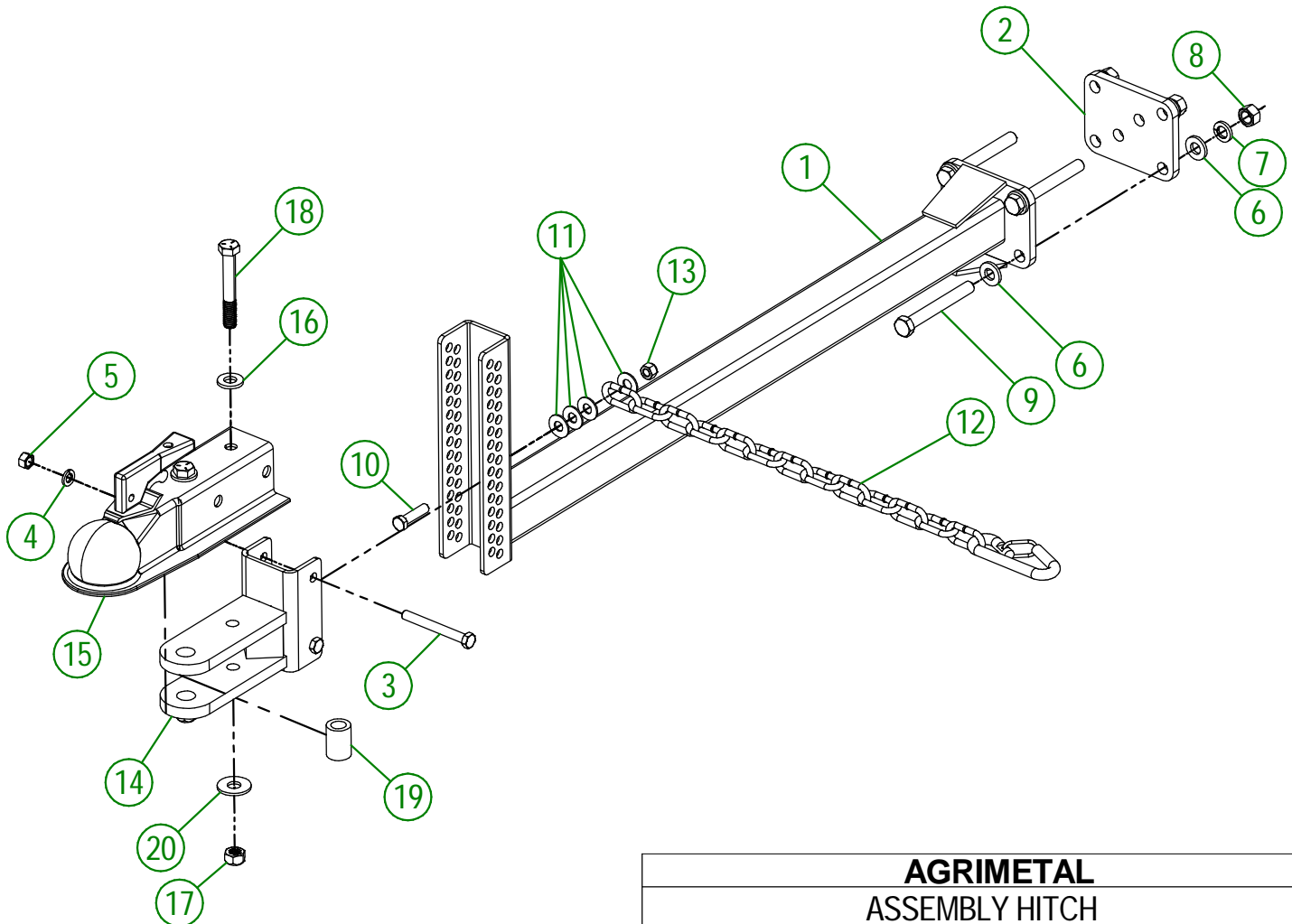

AGRIMETAL	
ASSEMBLY HITCH	
CREATION : 16/10/24	ASSEMBLY : 33-55-0040
REVISION : 29/04/25	AUTHOR : J.KABWE

#	PART #	Qty	TITLE
1	33-55-2530	1	ASSEMBLY SUBARU ENGINE
2	NC01-17-0118	4	HEX. BOLT GR2 ZINC 3/8-16 X 2"
3	01-01-2485	4	FLAT WASHER
4	21-01-0950	4	FLAT WASHER 10GA 1.005" DIA X 25/64"
5	NC02-32-0012	4	LOCK WASHER ZINC 3/8"
6	NC02-07-0018	4	HEX. NUT ZINC 3/8-16
7	33-22-4615	4	SHIM
8	33-55-2500	1	ASSEMBLY BATTERY BLACK CABLE #4

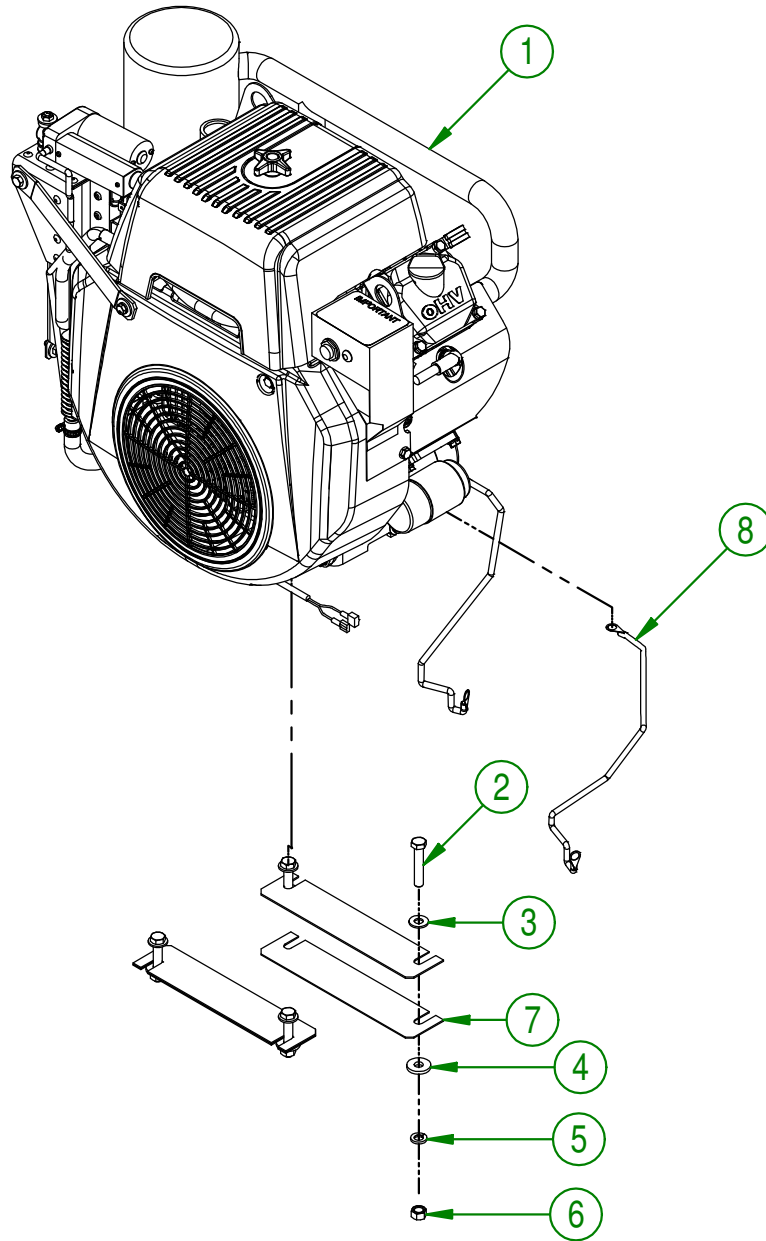

AGRIMETAL	
ASSEMBLY SUBARU ENGINE 28 HP	
CREATION : 07/11/17	ASSEMBLY : 33-57-2540
REVISION : 08/01/18	AUTHOR : J.KABWE Page 8 de 17

#	PART #	Qty	TITLE
1	33-55-1505	1	ASSEMBLY BATTERY RED CABLE #4
2	NC13-37-0636	1	EXHAUST
3	33-55-2605	1	ASSEMBLY ACTUATOR 12 VOLTS
4	33-01-7610	1	GAS CONTROL LEVER
5	NC02-32-0010	1	LOCK WASHER ZINC 1/4"
6	NC01-37-0003	2	HEX. BOLT GR8 1/4-28 X 5/8"
7	NC13-25-0110	1	SNUG-FIT DAMPING LOOP CLAMP
8	NC13-37-0637	1	CONTROL PANEL
9	NC13-25-0308	1	NON-ISOLATED MALE TERMINAL
10	NC13-25-0382	1	FEMALE TERMINAL
11	36-01-2430	1	WASHER
12	NC01-97-0004	1	NYLON-INSERT LOCKNUT ZINC 1/4-28

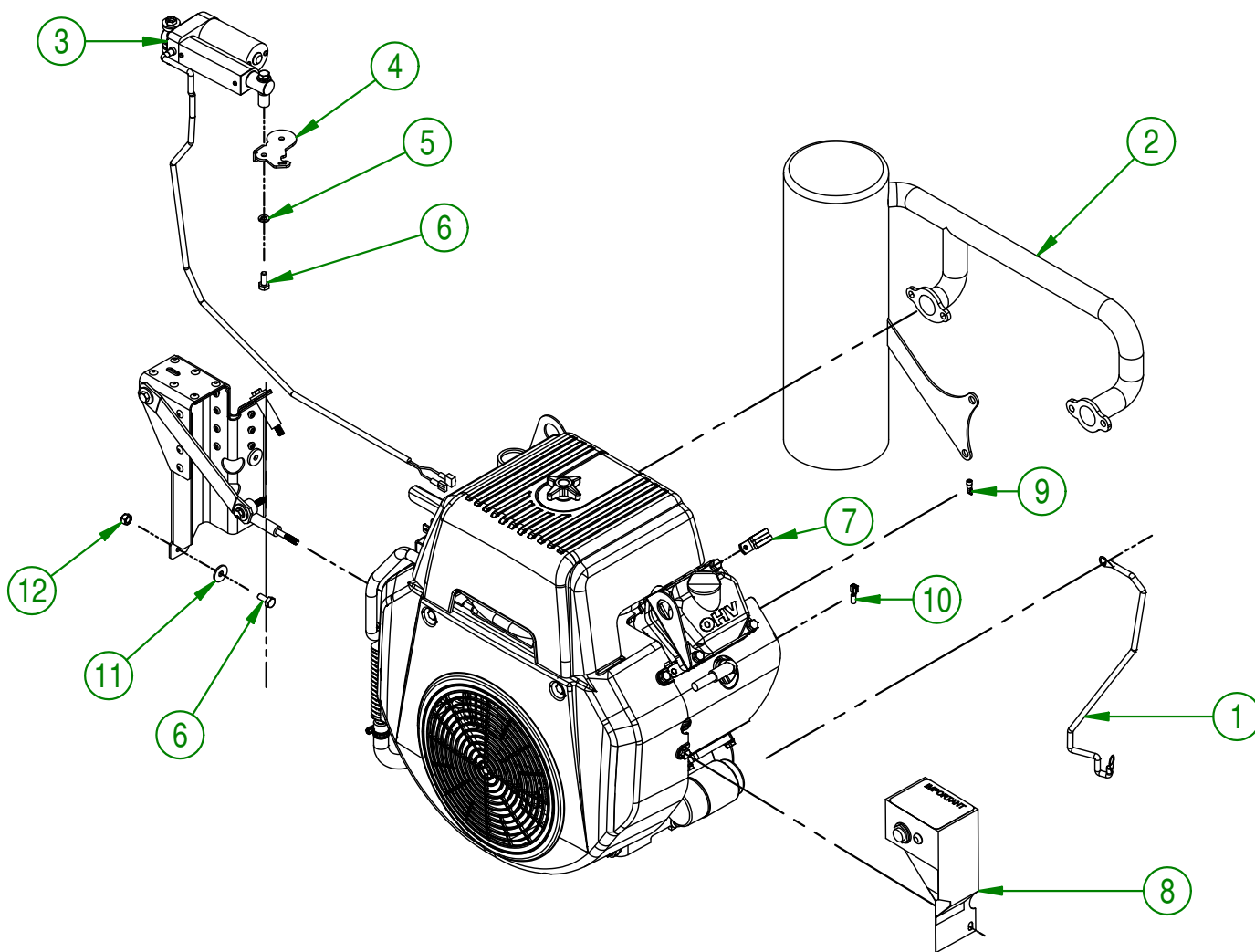

AGRIMETAL	
ASSEMBLY SUBARU ENGINE	
CREATION : 07/11/17	ASSEMBLY : 33-55-2530
REVISION : 29/08/19	AUTHOR : Production Page 9 de 17

#	PART #	Qty	TITLE
1	33-55-2575	1	ACTUATOR SUPPORT
2	33-01-1025	1	ACTUATOR SUPPORT REINFORCEMENT
3	33-01-1520	3	WASHER
4	NC01-45-0127	1	CAP SCREW GR8.8 NC ZINC 6mm X 80 mm
5	33-21-0090	1	ACTUATOR SUPPORT BUSHING
6	NC01-45-0122	1	CAP SCREW GR8.8 NC ZINC 6mm X 55 mm
7	33-21-0093	1	ACTUATOR SUPPORT BUSHING
8	36-01-2430	3	WASHER
9	NC01-37-0004	1	HEX. BOLT GR2 ZINC 1/4-28 X 3/4"
10	NC01-97-0004	1	NYLON-INSERT LOCKNUT ZINC 1/4-28
11	NC02-32-0010	1	LOCK WASHER ZINC 1/4"
12	33-21-0095	1	ACTUATOR SUPPORT BUSHING
13	NC01-45-0119	1	CAP SCREW GR8.8 NC ZINC 6mm X 40 mm

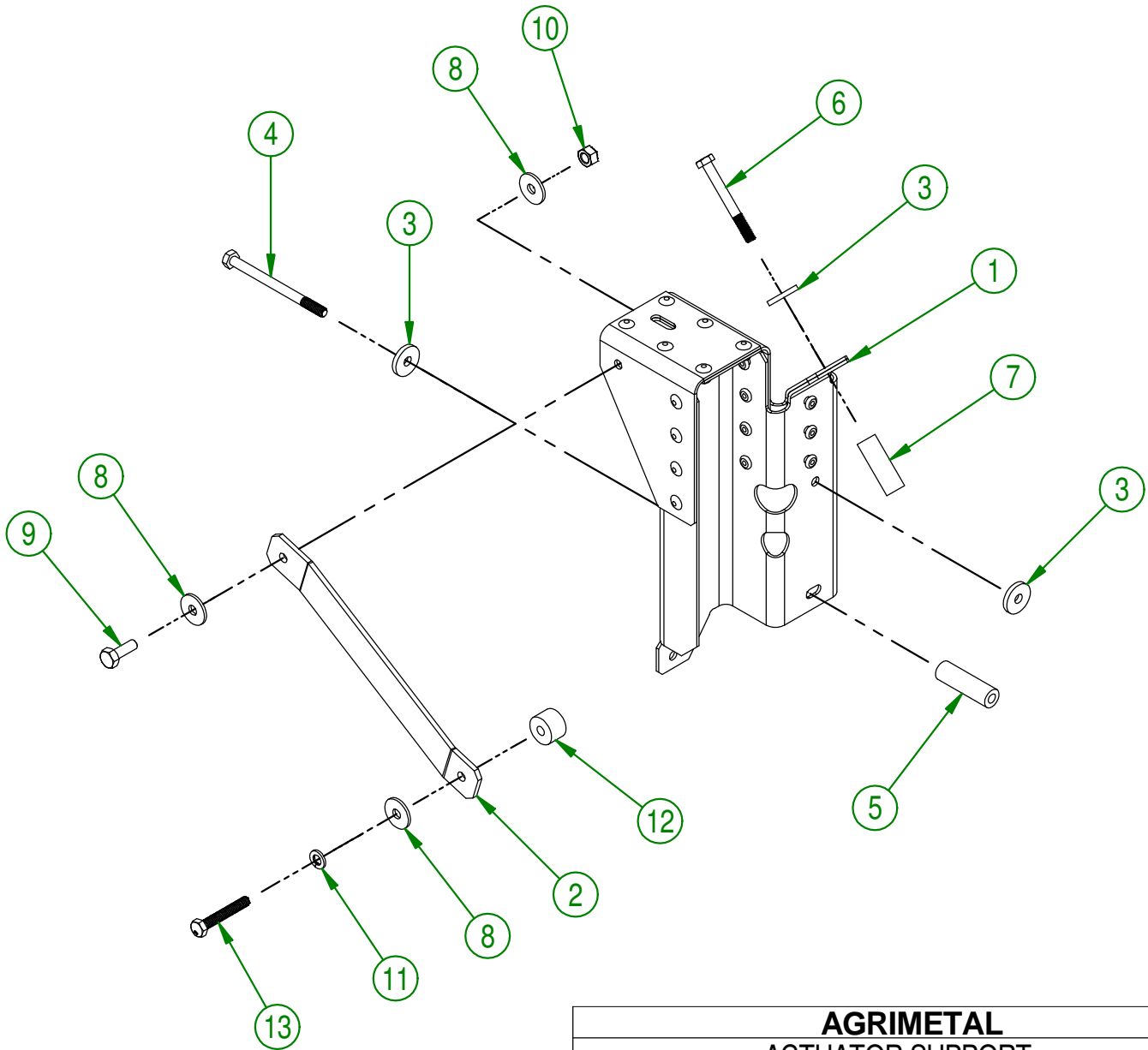

AGRIMETAL	
ACTUATOR SUPPORT	
CREATION : 13/12/16	ASSEMBLY : 33-57-2602
REVISION : 14/11/17	AUTHOR : J. HOULE Page 10 de 17

#	PART #	Qty	TITLE
1	33-55-0100	1	ACTUATOR 12 VOLTS
2	33-13-0612	1	ROD END ACTUATOR
3	NC01-37-0003	1	HEX. BOLT GR8 1/4-28 X 5/8"
4	NC02-32-0010	1	LOCK WASHER ZINC 1/4"
5	NC02-25-0007	1	WASHER ZINC 0.281 = 9/32
6	NC01-37-0011	1	HEX. BOLT GR8 1/4-28 X 2 1/4
7	33-42-0120	2	PIVOT BUSHING
8	NC02-14-1200	1	TWO WAY LOCK NUT 1/4-28
9	36-01-2430	4	WASHER
10	NC01-97-0004	1	NYLON-INSERT LOCKNUT ZINC 1/4-28

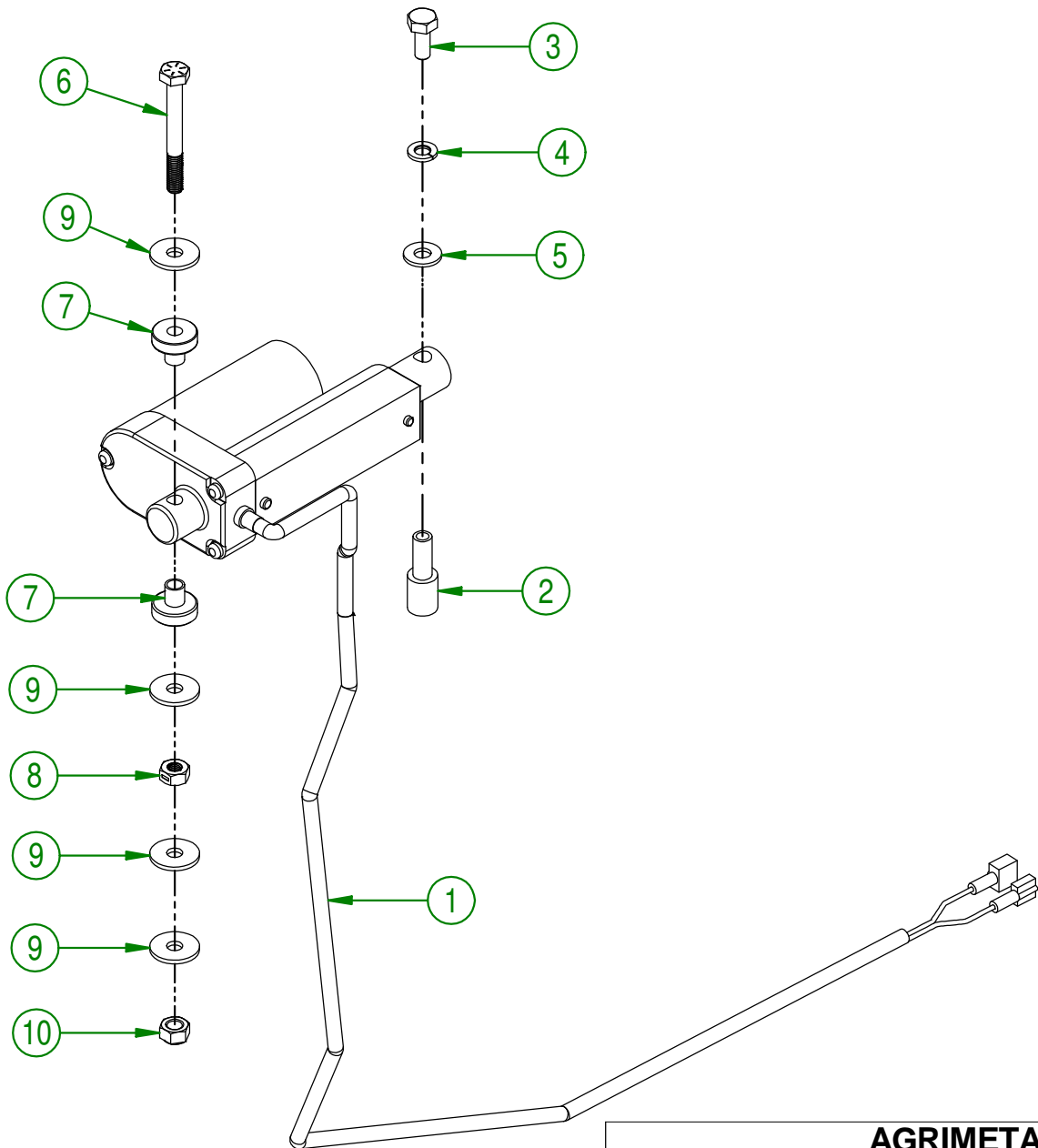

AGRIMETAL	
ASSEMBLY ACTUATOR 12 VOLTS	
CREATION : 15/07/16	ASSEMBLY : 33-55-2605
REVISION : 24/01/18	AUTHOR : J.KABWE Page 11 de 17

#	PART #	Qty	TITLE
1	33-04-1600	2	FLANGE
2	33-21-0055	4	SLEEVE
3	01-01-0925	4	WASHER
4	33-01-7570	2	WASHER
5	NC14-62-0016	1	QD BUSHING SH I 1/4"
6	NC14-62-0211	1	QD BUSHING SH I 7/16"
7	33-20-0152	2	SPACER
8	NC01-37-0253	4	HEX. BOLT GR8 ZINC 1/2-20 X 2 1/2"
9	NC01-94-0013	4	NYLON NUT ZINC 1/2-20"
10	NC01-65-0087	1	KEY 1/4 X 1/4 X 1 1/2"

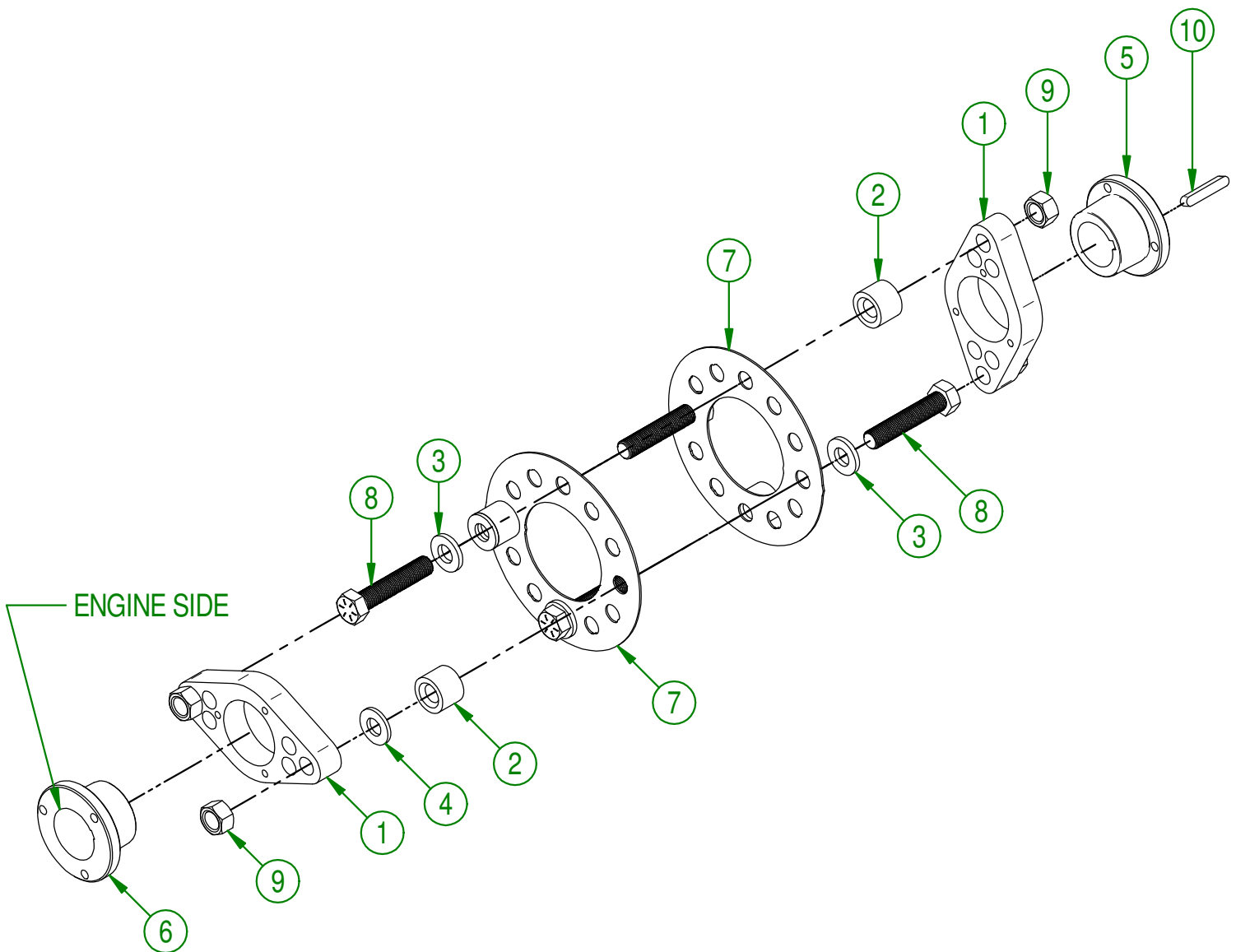

AGRIMETAL
COUPLING ASSEMBLY

CREATION : 03/11/17
 REVISION : 05/10/18

ASSEMBLY : **33-57-0046**
 AUTHOR : J.KABWE Page 12 de 17

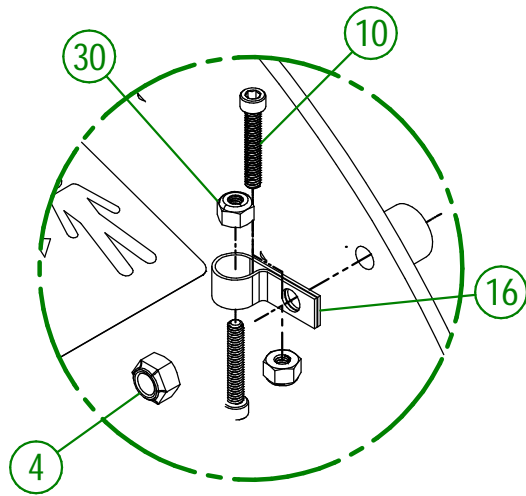
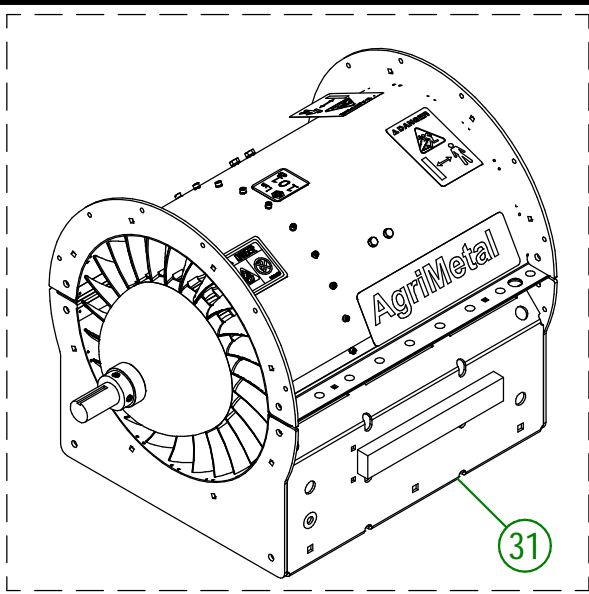

DETAIL A

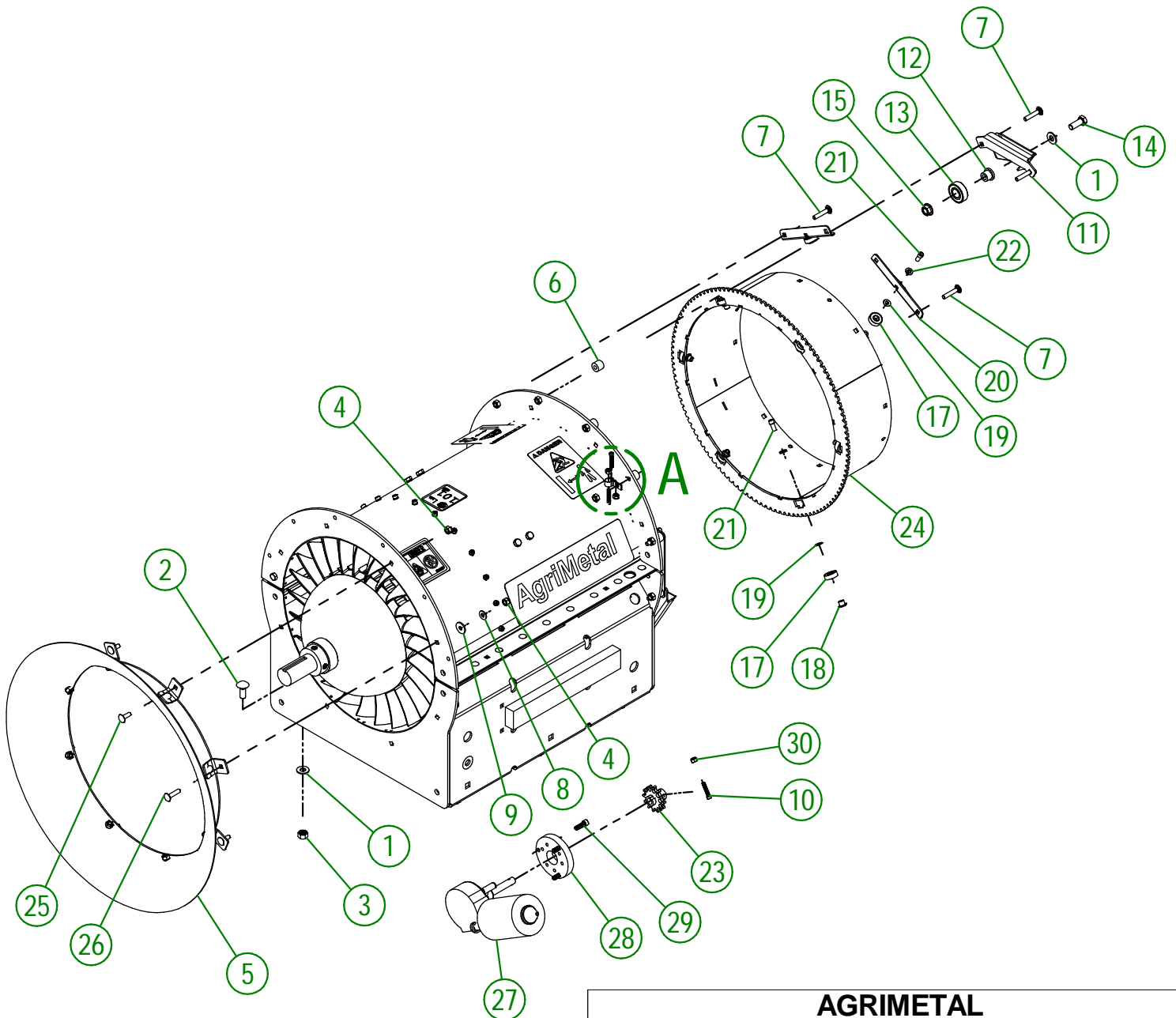

**AGRIMETAL
TURBINE**

CREATION : 21/06/24
REVISION : 09/10/24

ASSEMBLY : **33-57-0080**
AUTHOR : D. CHASSÉ

33-57-0080

#	PART #	QTY	TITLE
1	01-01-2485	9	FLAT WASHER 14 GA X 13/16"OD X 25/64" ID
2	NC01-04-0109	6	CARR. BOLT GR2 ZINC 3/8-16 X 1"
3	NC01-93-0011	6	LOCK NUT 3/8-16
4	NC01-96-0009	41	NYLON-INSERT LOCKNUT ZINC 1/4-20
5	33-55-0085	1	AIR INTAKE ASSY.
6	33-21-0080	12	SPACER
7	NC01-04-0006	12	CARR. BOLT GR2 ZINC 1/4-20 X 1 1/4"
8	NC02-25-0007	2	WASHER ZINC 0.281 = 9/32
9	36-01-2430	3	FLAT WASHER 14GA X 17/64" I.D. X 13/16" O.D.
10	NC02-50-0069	3	SOCKET CAP SCREW T. RON 8-32 X 1"
11	33-50-0555	3	WELD ASSEMBLY BEARING SUPPORT
12	33-21-0060	3	BEARING HOLDER
13	NC14-75-0068	3	BALL BEARING 99502H
14	NC01-17-0114	3	HEX. BOLT GR2 ZINC 3/8-16 X 1"
15	NC02-14-0019	3	FLANGE NUT HEX. NC 3/8-16 GR. B
16	NC13-25-0233	1	VINYLE PROTECTOR COLLAR
17	NC14-75-0153	12	BALL BEARING R6 2RS 3/8" X 7/8" X 0.281"
18	33-25-2410	12	BEARING BUSHING
19	33-03-4605	12	BEARING SHIM 1/4" ALUMINUM
20	33-01-2425	6	BEARING HOLDER BRACKET
21	NC02-51-0578	12	SOCKET CAP SCREW T. RON. NF 1/4-28 X 1/2 STAINLESS
22	NC02-32-0010	12	LOCK WASHER ZINC 1/4"
23	33-55-0035	1	GEARED CROWN SPROCKET
24	33-50-0018	1	DUCT COLECTOR
25	NC01-04-0003	6	CARR. BOLT GR2 ZINC 1/4-20 X 3/4"
26	NC01-04-0005	2	CARR. BOLT GR2 ZINC 1/4-20 X 1"
27	33-35-0005	1	OUTLET MOTOR
28	33-21-0100	1	ENGINE CONVERSION PLATE
29	NC02-50-1072	3	SOCKET CAP SCREW M6 X 20mm
30	NC01-96-0004	3	8-32 JAM NUT
31	33-57-0020	1	REGROUP. ENSEMBLE DE TURBINE (NEUF)

#	PART #	Qty	TITLE
1	NC01-96-0009	2	NYLON-INSERT LOCKNUT ZINC 1/4-20
2	NC01-04-0027	2	CARR. BOLT 1/4-20 X 6" LG
3	NC01-04-0056	2	CARR. BOLT 5/16-18 X3/4"
4	33-01-3015	1	BATTERY STRAPE
5	NC02-32-0011	2	LOCK WASHER ZINC 5/16"
6	NCI3-12-0001	1	12 VOLTS BATTERY
7	NC02-07-0017	2	HEX. NUT 5/16-18
8	NCI3-80-0267	1	RED PROTECTOR FOR BATTERY POST
9	NCI3-80-0268	1	BLACK PROTECTOR FOR BATTERY POST

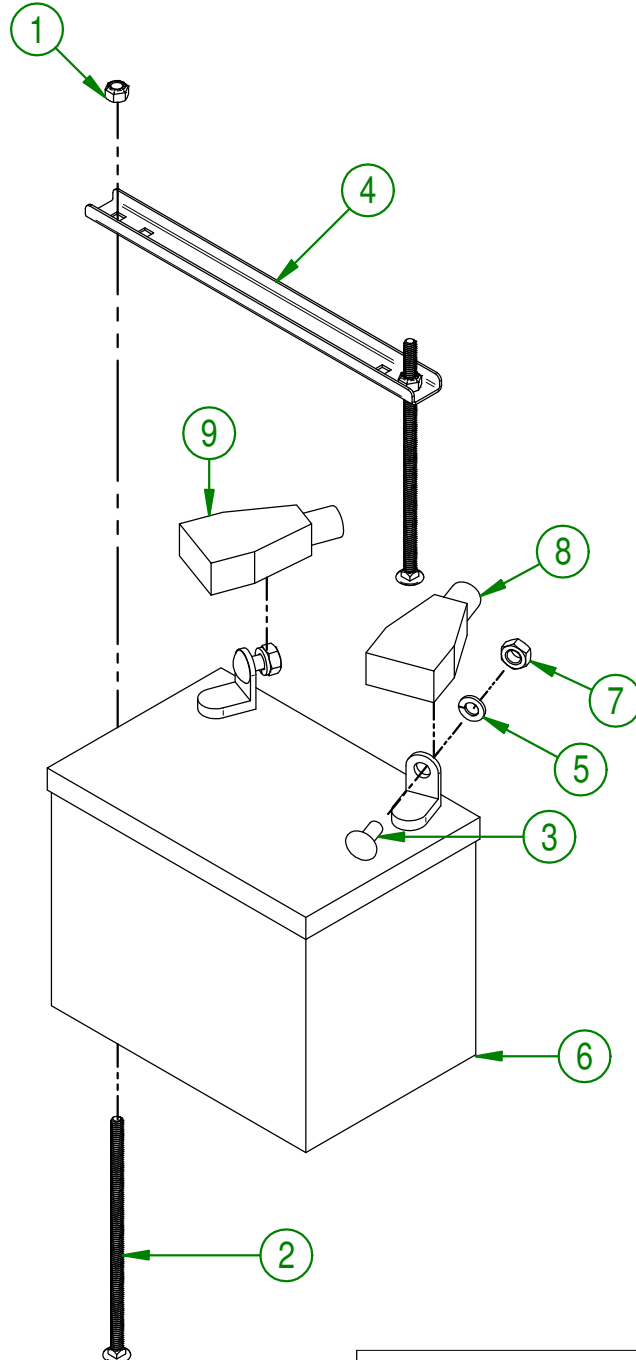

AGRIMETAL	
12 VOLTS BATTERY GROUP.	
CREATION : 31/10/17	ASSEMBLY : 33-57-0055
REVISION : 08/01/18	AUTHOR : J.KABWE Page 15 de 17

#	PART #	Qty	TITLE
1	NCI3-30-0237	1	PLASTIC TUBE FOR OPERATOR'S MANUAL
2	NC01-04-0003	3	CARR. BOLT GR2 ZINC 1/4-20 X 3/4"
3	NC02-25-0007	3	WASHER ZINC 0.281 = 9/32
4	NC01-96-0009	3	NYLON-INSERT LOCKNUT ZINC 1/4-20
5	33-98-0620	1	OPERATION MANUAL TB 280 & TB 270

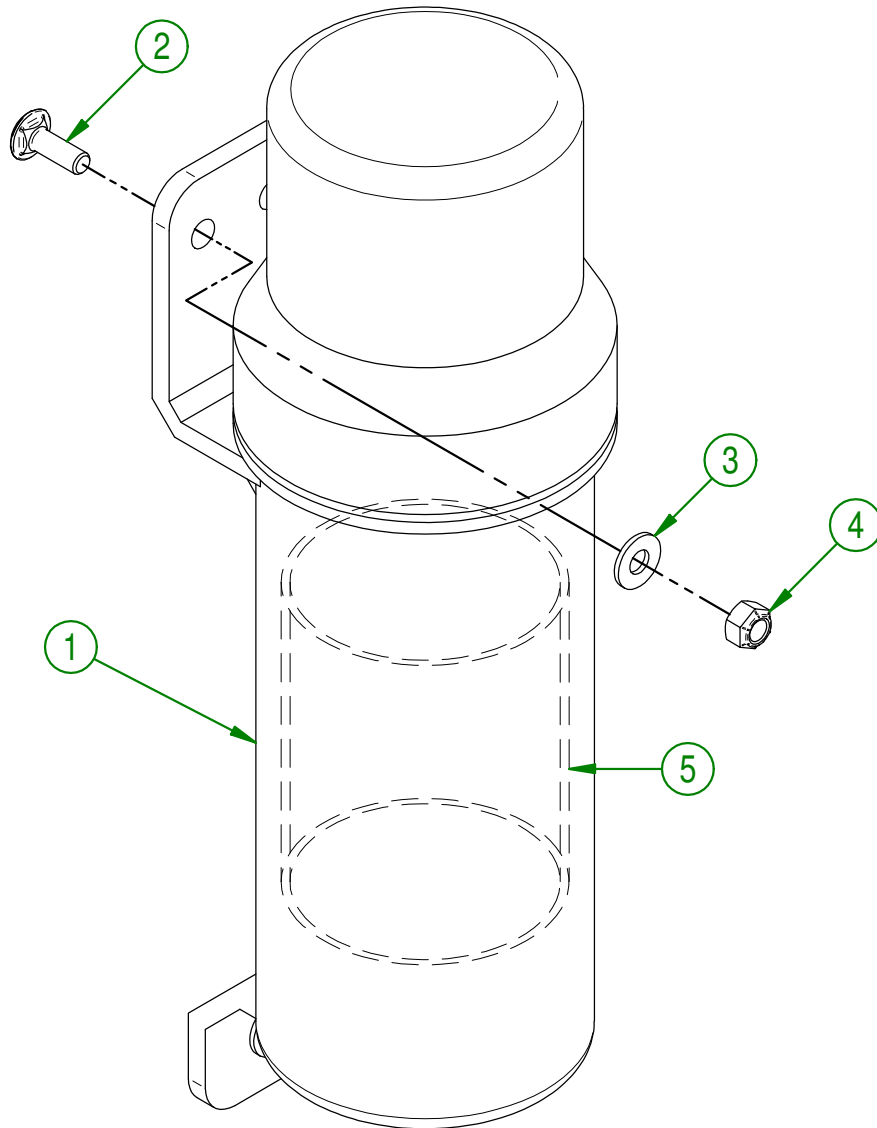

AGRIMETAL	
OPERATOR MANUEL TUBE ASSEMBLY	
CREATION : 27/10/17	ASSEMBLY : 33-57-2565
REVISION : 08/01/18	AUTHOR : J.KABWE Page 16 de 17

#	PART #	Qty	TITLE
1	NCI3-33-0052	2	STICKER FRAME LEVEL
2	NCI3-33-0251	1	STICKER TO PROGRAM REMOTE CONTROL
3	NCI3-33-0183	1	STICKER CAUTION OPERATION MANUAL
4	NCI3-33-0227	1	STICKER FUSE 15 AMP MAXIMUM
5	NCI3-33-0178	1	STICKER IMPORTANT PLEASE CHECK OIL LEVEL...
6	NCI3-33-0192	2	STICKER (PROJECTION RISK)
7	NCI3-33-0185	1	STICKER PICTOGRAM (FIRE + CIGARETTE)
8	NCI3-33-0035	2	STICKER AGRIMETAL

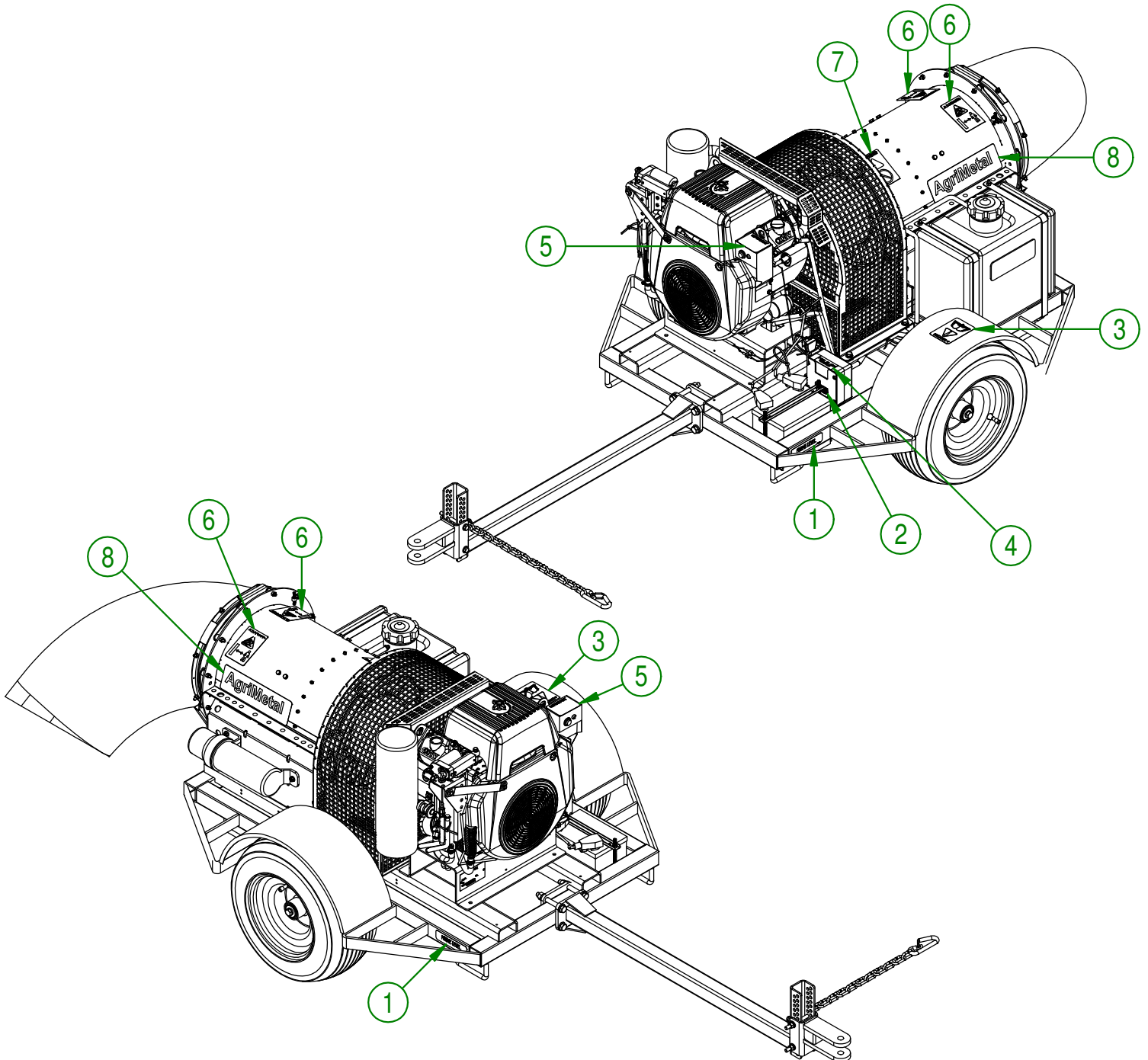

AGRIMETAL
TURBINE BLOWER 280

CREATION : 08/11/17
REVISION : 15/10/18

ASSEMBLY : **33-99-2500**
AUTHOR : J.KABWE Page 17 de 17