

# AgriMetal

## PARTS LIST

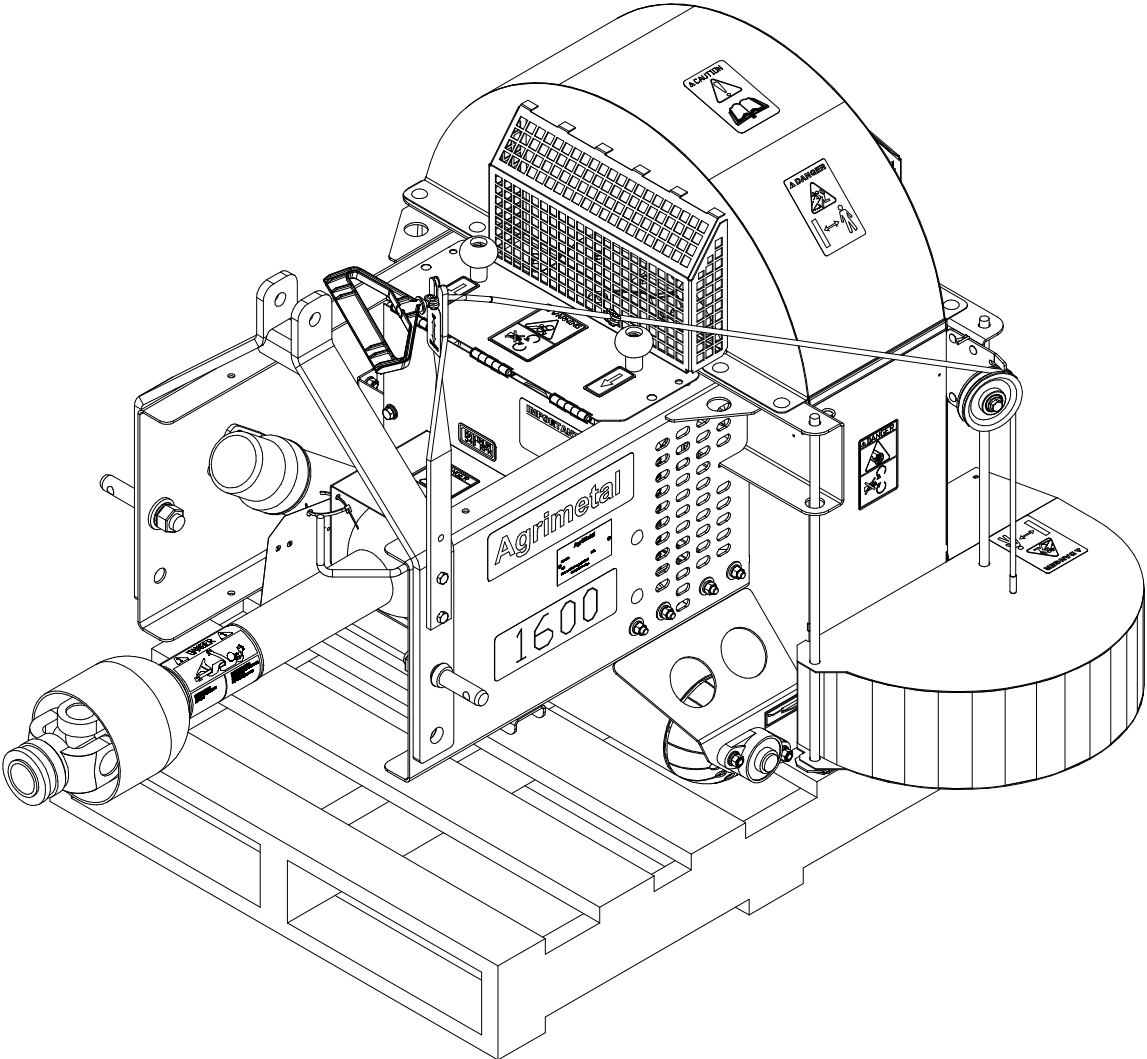

**BW 1600**

#	PART #	Qty	TITLE
1	25-55-0710	1	SERIAL NUMBER PLATE

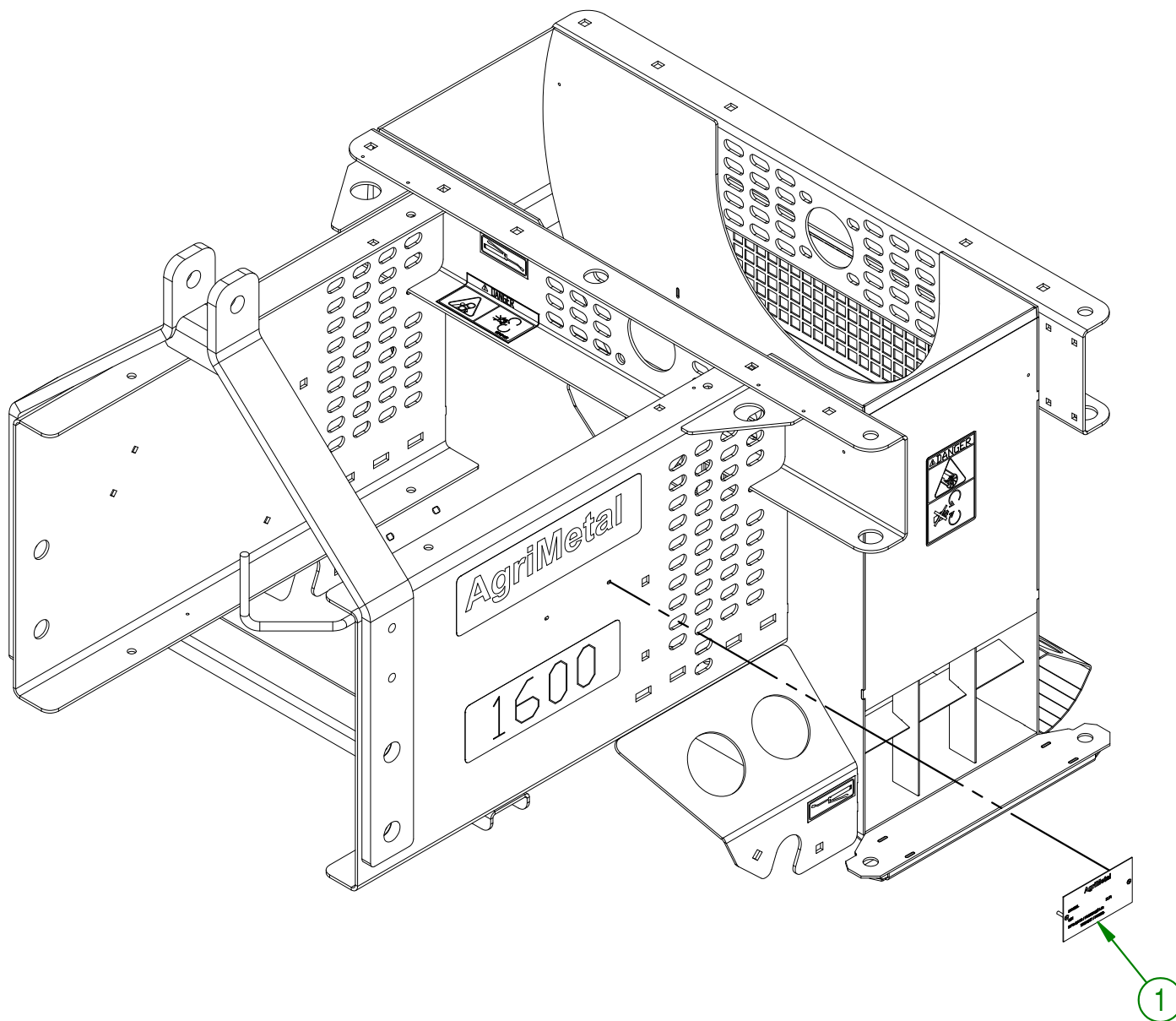

<b>AGRIMETAL</b>			
<b>ASSEMBLY CASING BW 1600</b>			
CREATION : 20-06-2016	ASSEMBLY :	32-57-0000	
REVISION : 19-09-2018	AUTHOR : F.H.	Page 1 de 14	

32-57-0025

#	PART #	Qty	TITLE
1	32-46-0010	1	FRONT ROLLER
2	NC14-75-0019	2	FLANGE PILLOW BLOCK BEARING UCFL205-16 Ø 1"
3	01-09-0000	4	BEARING RACE (UCFL205-16)
4	NC01-04-0110	4	CARR. BOLT GR2 ZINC 3/8-16 X 1 1/4"
5	01-01-2485	4	FLAT WASHER 14 GA X 13/16"OD X 25/64" ID
6	NC02-32-0012	4	LOCK WASHER ZINC 3/8"
7	NC02-07-0018	4	HEX. NUT ZINC 3/8-16

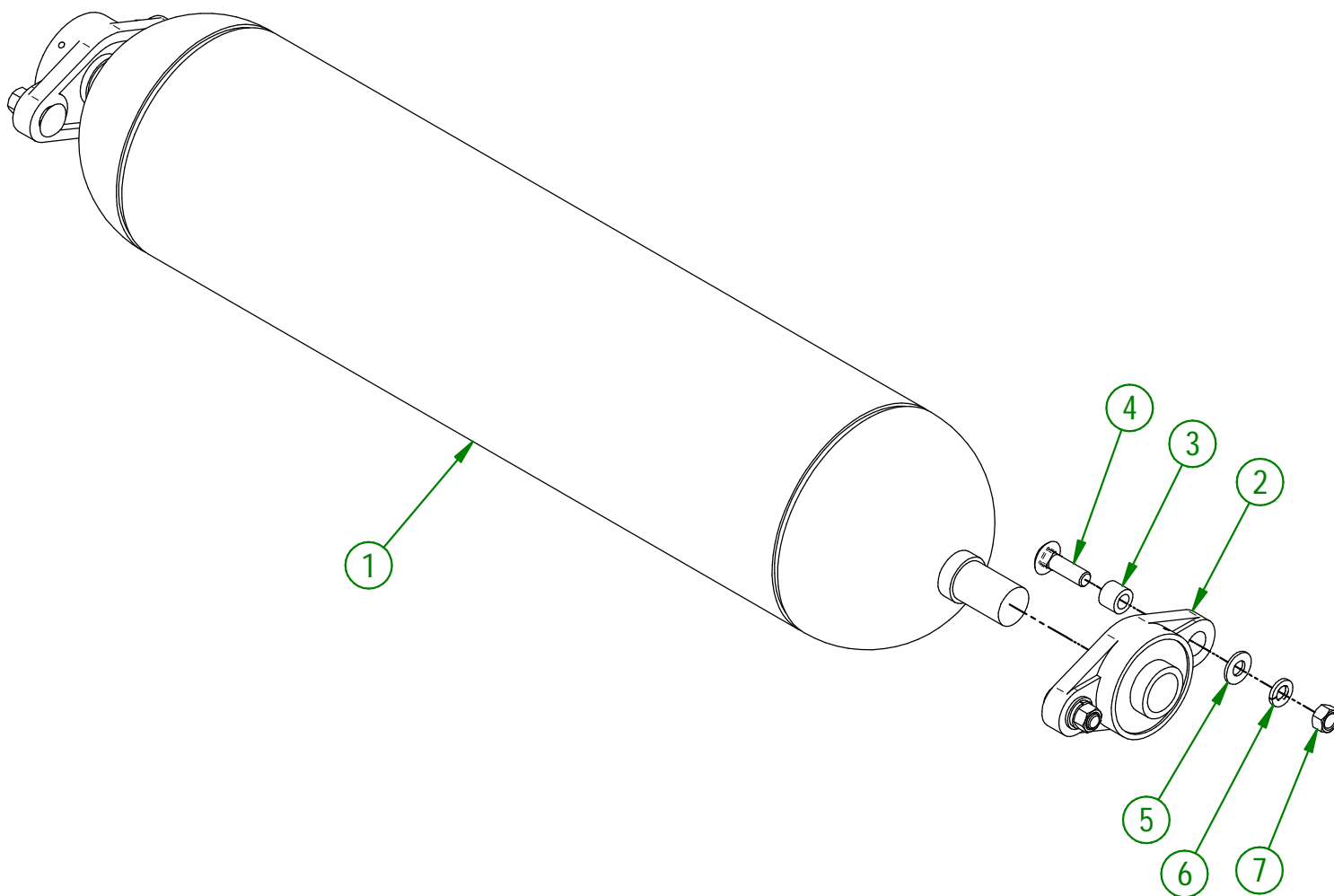

<b>AGRIMETAL</b>	
<b>ASSEMBLY LARGE TURF ROLLER</b>	
CREATION : 2016-06-20	ASSEMBLY : 32-57-0025
REVISION : 2022-09-30	AUTHOR : F.H.

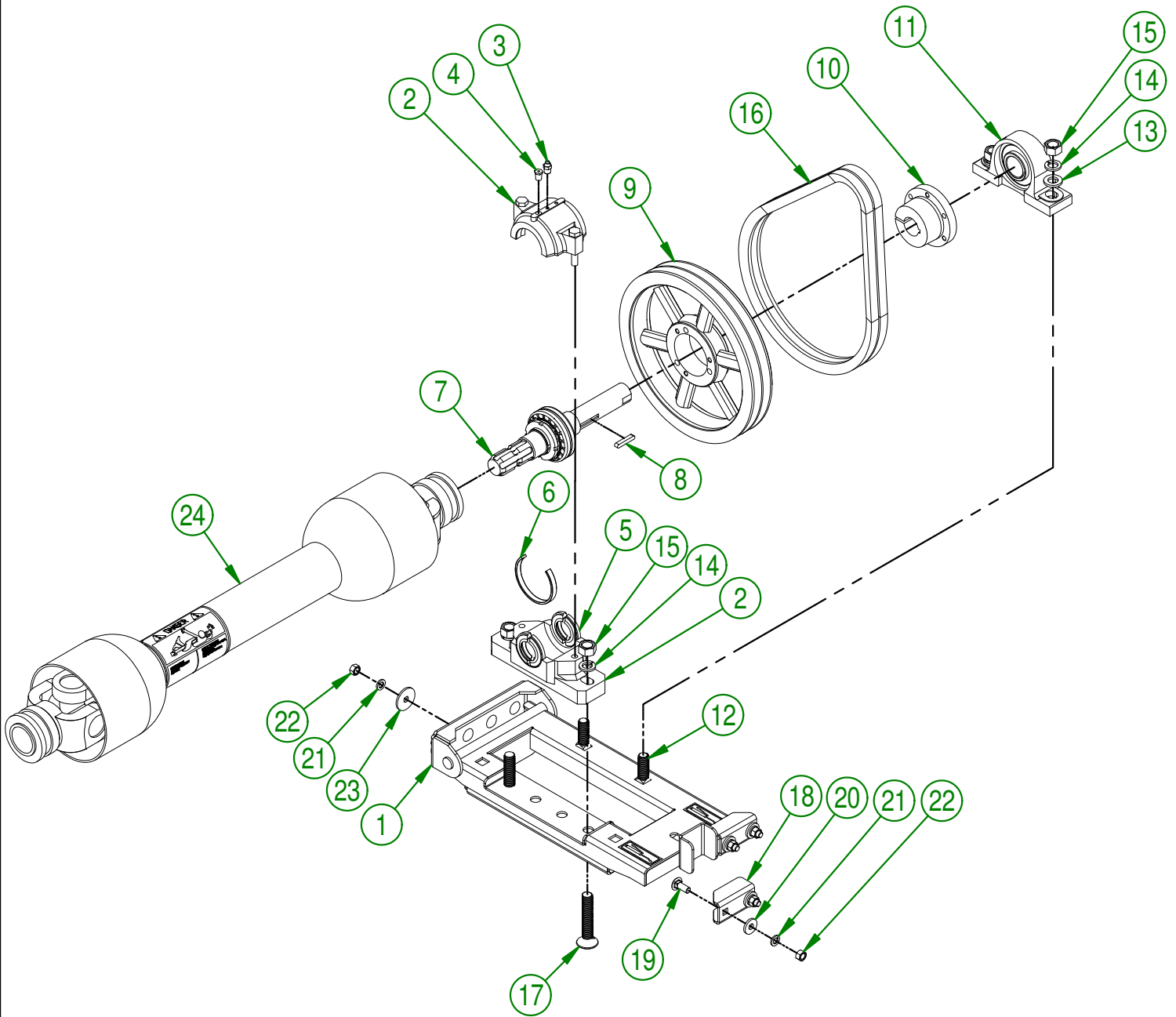

<b>AGRIMETAL</b>			
<b>ASSEMBLY BEARING BASE</b>			
CREATION : 20-06-2016	ASSEMBLY :	32-57-0035	
REVISION : 04-02-2019	AUTHOR :	Page 3 de 14	

#	PART #	QTY	TITLE
1	32-57-0020	1	ASSEMBLY BEARING BASE
2	NC14-75-0131	1	PILLOW BLOCK CASING
3	NC01-69-0791	1	GREASE FITTING 1/8 NPT STRAIGHT
4	32-45-0000	1	BEARING PLUG
5	NC14-75-0130	1	SET JOINT 1 1/2"
6	NC14-75-0129	1	BEARING SHIM 1 1/2"
7	32-55-0063	1	DRIVE SHAFT
8	NC01-65-0087	1	KEY 1/4 X 1/4 X 1 1/2"
9	NC14-62-0184	1	PULLEY QD 2V 1/2-5/8 X 11.35 OD X SK
10	NC14-62-0019	1	QD BUSHING SK 1 1/4"
11	NC14-75-0034	1	PILLOW BLOCK BEARING 1 1/4" DIA.
12	NC01-04-0268	2	BOLT CARR. GR2 ZINC 5/8-11 X 2"
13	32-01-1395	2	BEARING WHASER $\varnothing$ 3/4"
14	NC02-32-0016	4	LOCK WASHER ZINC 5/8"
15	NC02-07-0022	4	HEX. NUT ZINC 5/8-11
16	NC14-25-1079	2	V BELT 21/32 COGGED RAW EDGE BX-40
17	NC01-04-0275	2	BOLT CARR. GR2 ZINC 5/8-11 X 3 1/2"
18	32-01-1080	2	BEARING BASE STOPPER
19	NC01-04-0109	8	CARR. BOLT GR2 ZINC 3/8-16 X 1"
20	21-01-0950	4	FLAT WASHER 10GA 1.005" DIA X 25/64"
21	NC02-32-0012	8	LOCK WASHER ZINC 3/8"
22	NC02-07-0018	8	HEX. NUT ZINC 3/8-16
23	01-33-0010	4	WASHER
24	32-34-0035	1	PTO SHAFT T20 X 35.35"

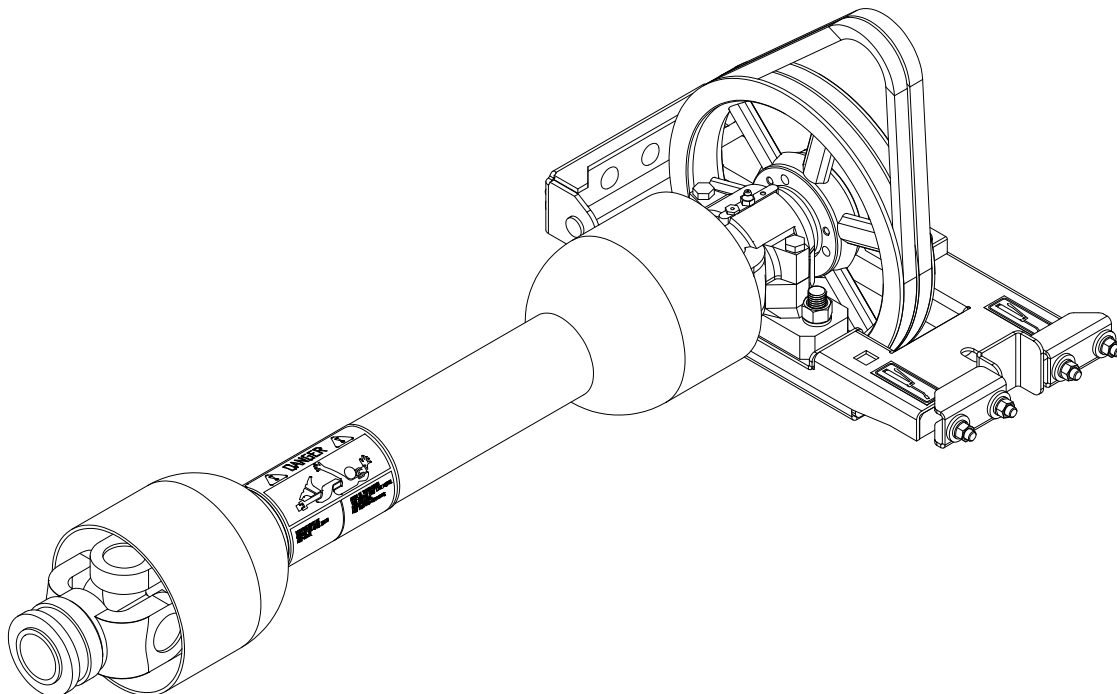

#	# DE PIÈCE	QTÉ	TITRE
1	NC17-46-0018	2	HANDLE KNOB
2	NC01-17-0119	2	HEX. BOLT GR2 ZINC 3/8-16 X 2 1/4"
3	NC02-32-0012	6	LOCK WASHER ZINC 3/8"
4	NC02-07-0018	2	HEX. NUT ZINC 3/8-16
5	01-01-2485	6	FLAT WASHER 14 GA X 13/16"OD X 25/64" ID
6	32-57-4100	1	BELT GUARD
7	NC01-17-0112	4	HEX. BOLT GR2 ZINC 3/8-16 X 3/4"
8	NC01-04-0055	2	CARR. BOLT GR2 ZINC 5/16-18 X 5/8"
9	NC01-96-0010	2	NYLON NUT HEX. ZINC 5/16-18

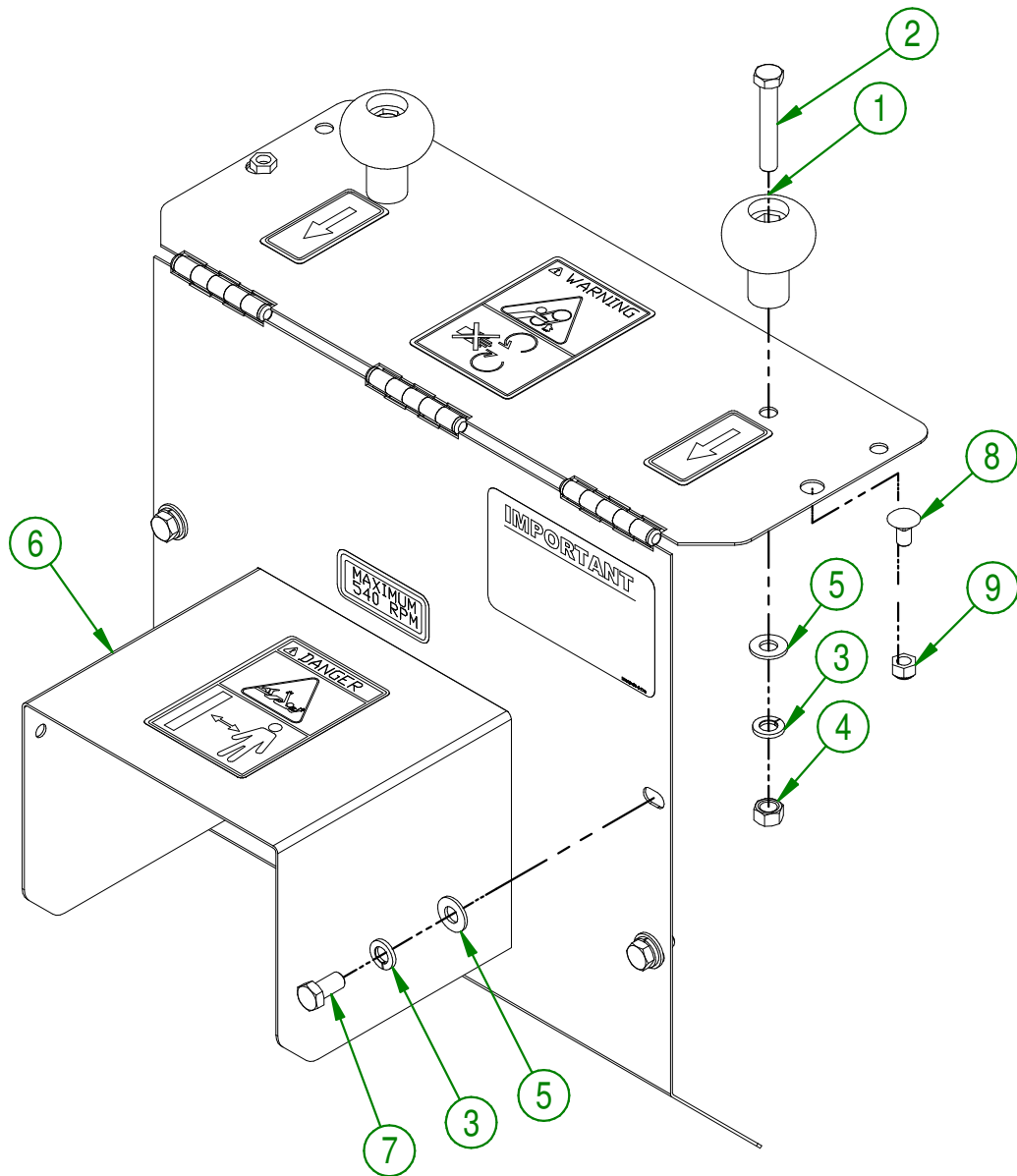

<b>AGRIMETAL</b>	
<b>ASSEMBLY BELT COVER</b>	
CREATION : 20-06-2016	ASSEMBLY : 32-57-0085
REVISION : 07-10-2021	AUTHOR :

#	PART #	Qty	TITLE
1	32-50-3530	1	WELD ASSEMBLY THREADED ROD
2	32-42-0115	1	SPRING GUIDE
3	32-42-0140	1	SPRING STOPPER
4	NC13-86-0083	1	BLUE SPRING 1/2" ID X 1" OD X 8"
5	NC02-25-0011	1	WASHER SAE ZINC 17/32 ID
6	32-01-3075	1	HANDLE
7	NC02-07-0020	2	HEX. NUT ZINC 1/2-13

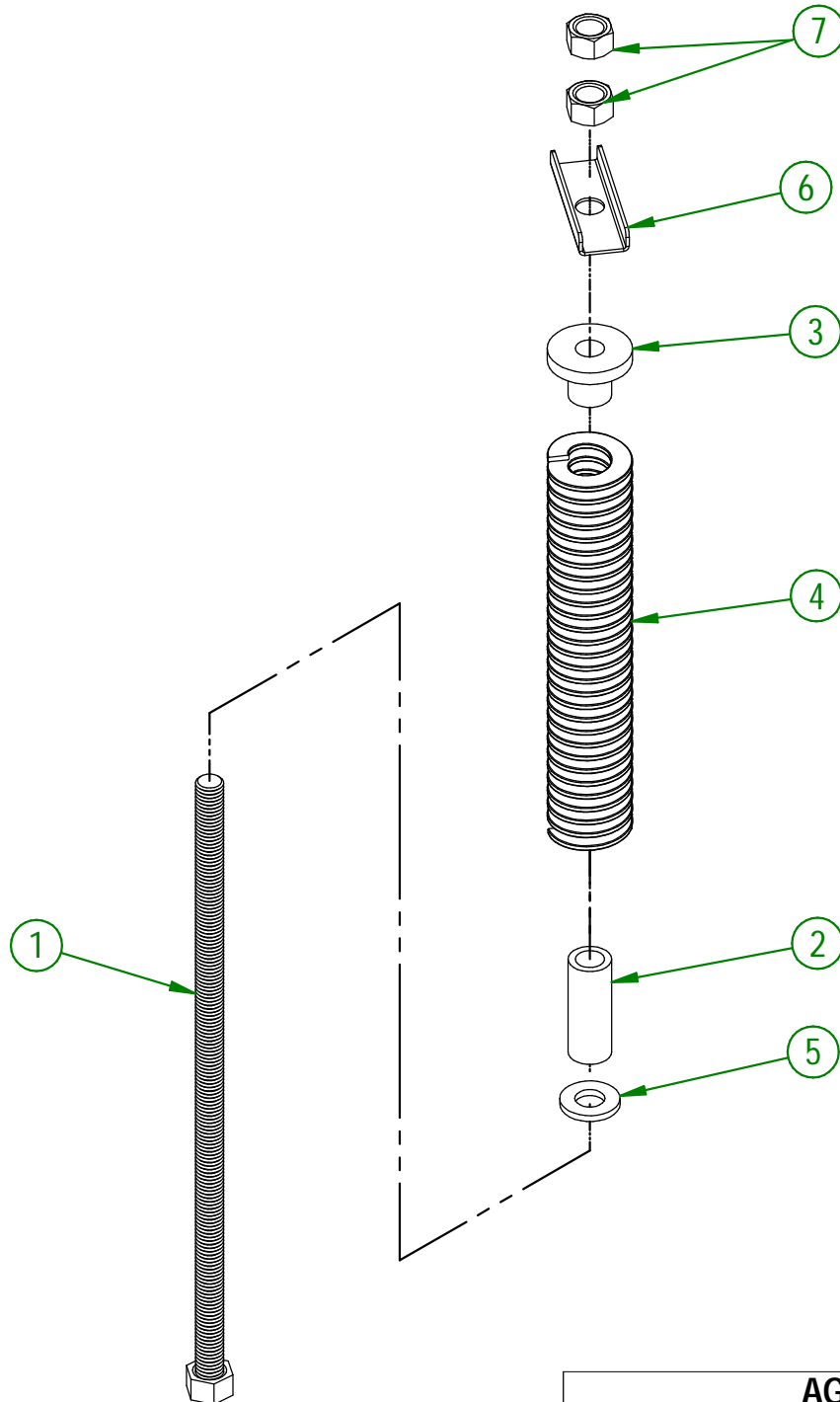

<b>AGRIMETAL</b>	
<b>ASSEMBLY BELT TENSIONER</b>	
CREATION : 2016-06-20	ASSEMBLY : 32-57-0040
REVISION : 2022-03-01	AUTHOR : F.H.

#	PART #	Qty	TITLE
1	32-50-0040	1	WELD ASSEMBLY BRACKET BELT COVER
2	NC01-04-0107	2	CARR. BOLT GR2 ZINC 3/8-16 X 3/4"
3	NC02-32-0012	2	LOCK WASHER ZINC 3/8"
4	NC02-07-0018	2	HEX. NUT ZINC 3/8-16

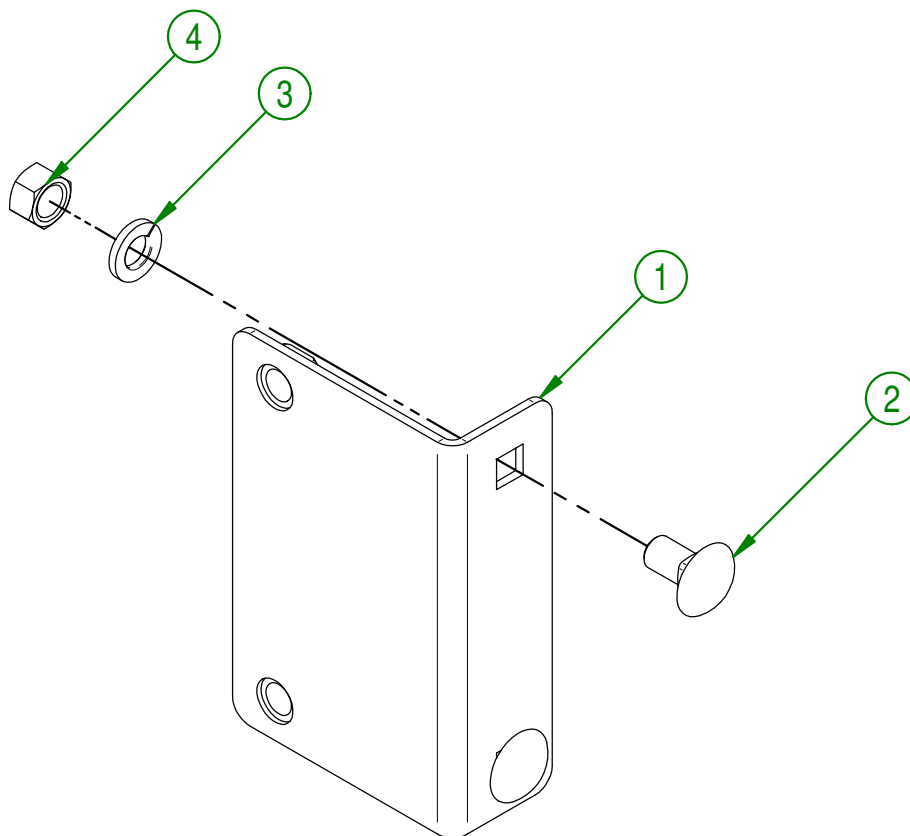

<b>AGRIMETAL</b>			
<b>ASSEMBLY BRACKET BELT COVER</b>			
CREATION : 2016-06-20	ASSEMBLY :	32-57-0055	
REVISION : 2017-12-21	AUTHOR : F.H.	Page 7 de 14	

#	PART #	Qty	TITLE
1	NC17-94-0009	1	IMPELLER SHAFT BW I600
2	NC14-75-0024	1	FLANGE BEARING 4 HOLES UCF207-20 I 1/4" DIA.
3	NC01-17-0249	4	HEX. BOLT GR2 ZINC 1/2-13 X I 1/2"
4	NC02-32-0014	4	LOCK WASHER ZINC 1/2"
5	NC02-07-0020	4	HEX. NUT ZINC 1/2-13
6	32-09-0600	3	IMPELLER SPACER
7	32-55-0050	1	ASSEMBLY IMPELLER
8	NC01-98-0020	1	NYLON NUT HEX. I 1/8 UNF-3B THIN
9	NC14-75-0023	1	FLANGE BEARING 4 HOLES UCF205-16 1" ID
10	23-01-3600	1	BEARING GUARD
11	NC01-17-0183	4	BOLT HEX. GR2 ZINC 7/16-14 X I 1/2"
12	NC02-25-0011	4	WASHER SAE ZINC 17/32 ID
13	NC02-32-0013	4	LOCK WASHER ZINC 0.4375 = 7/16
14	NC02-07-0019	4	NUT HEX. ZINC 7/16-14
15	NC14-62-0016	1	QD BUSHING SH I 1/4"
16	NC14-62-0135	1	PULLEY QD 2V 1/2-5/8 X 3.95 OD X SH
17	01-41-0910	2	KEY WAY

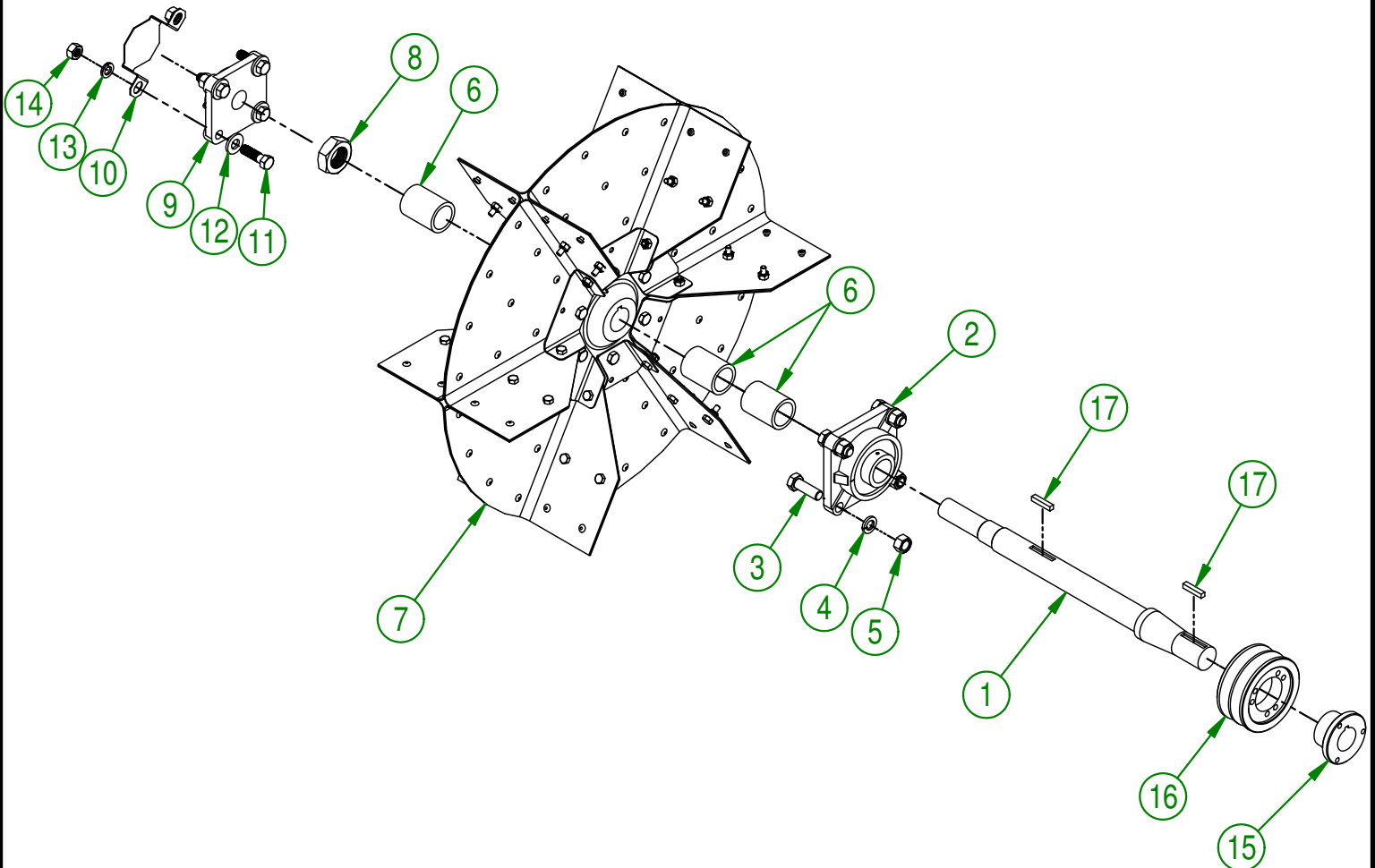
**AGRIMETAL****ASSEMBLY IMPELLER**

CREATION : 20-06-2016	ASSEMBLY :	32-57-0045
REVISION : 14-09-2018	AUTHOR : F.H.	Page 8 de 14

#	PART #	Qty	TITLE
1	32-57-0005	1	ASSEMBLY COVER CASING
2	NC01-04-0107	8	CARR. BOLT GR2 ZINC 3/8-16 X 3/4"
3	NC02-14-0019	10	FLANGE NUT HEX. NC 3/8-16 GR. B

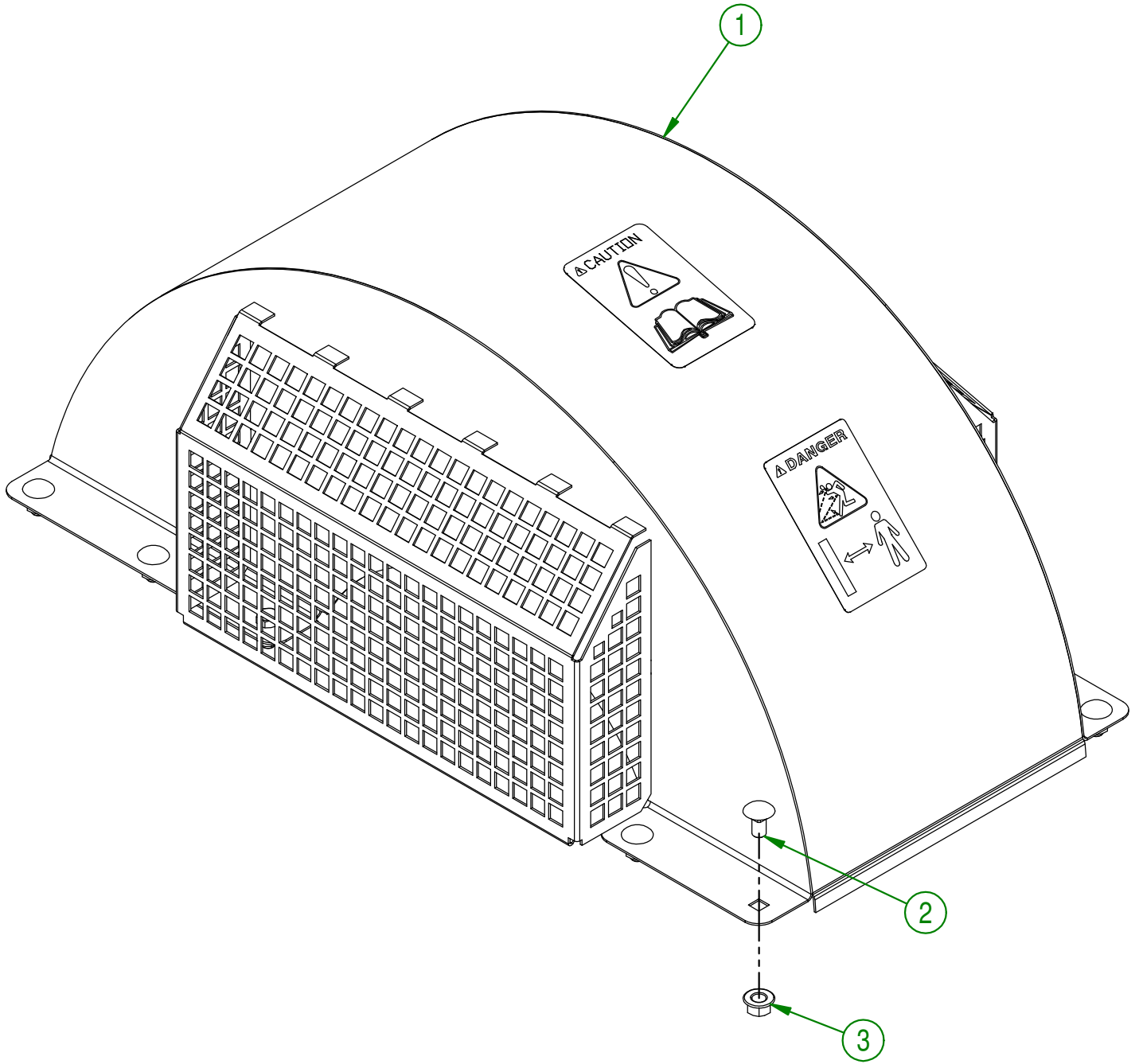

<b>AGRIMETAL</b>			
<b>ASSEMBLY COVER CASING</b>			
CREATION : 2016-06-20	ASSEMBLY :	32-57-0050	
REVISION : 2017-12-21	AUTHOR : F.H.	Page 9 de 14	

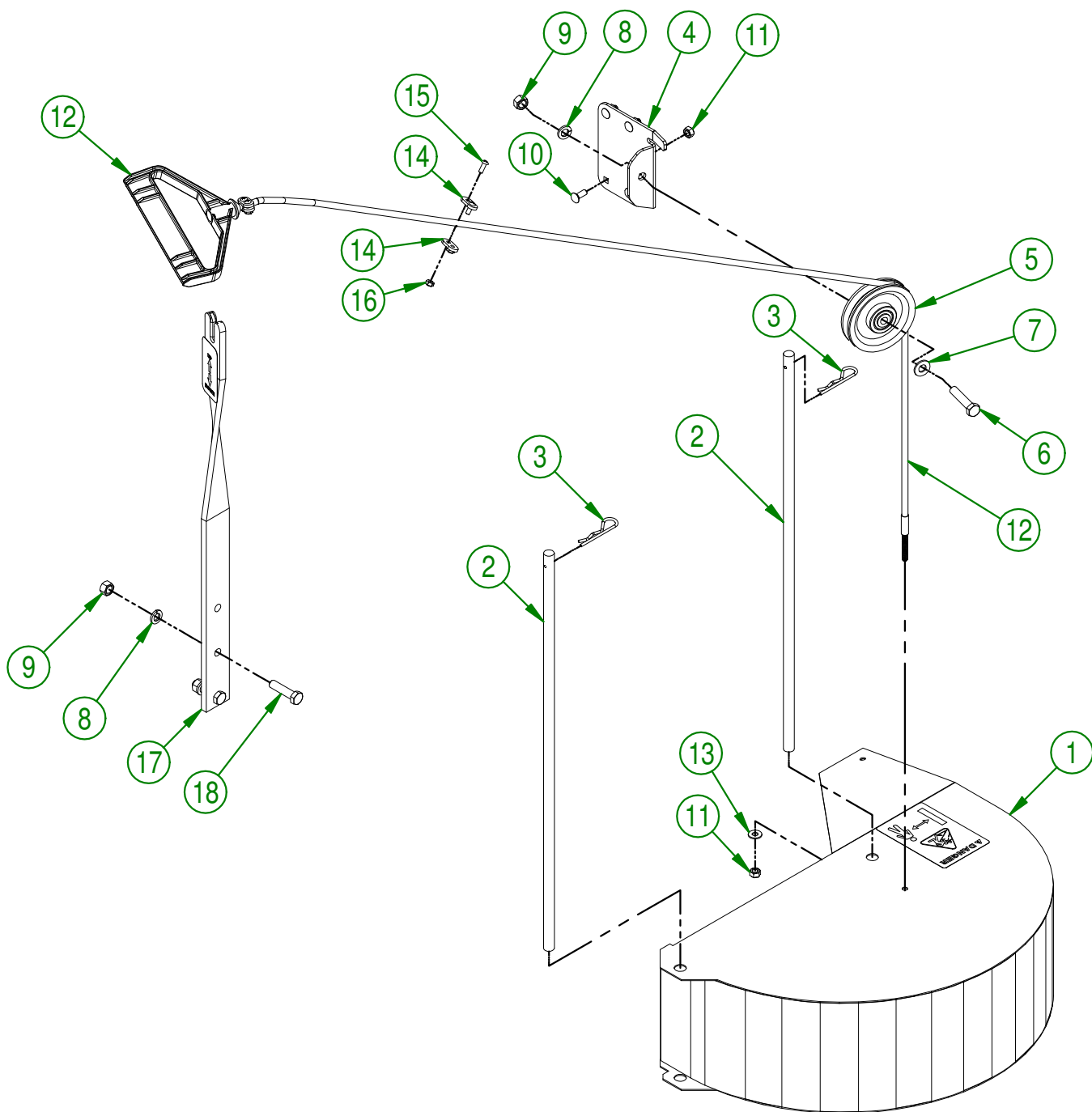

<b>AGRIMETAL</b>			
<b>ASSEMBLY 180° DEFLECTOR</b>			
CREATION : 2016-06-20	ASSEMBLY :	32-57-0090	
REVISION : 2017-12-22	AUTHOR : F.H.	Page 10 de 14	

32-57-0090

#	PART #	Qty	TITLE
1	32-57-0015	1	ASSEMBLY DEFLECTOR
2	32-13-0600	2	DEFLECTOR GUIDE BW 1600
3	NC01-63-0015	2	COTTER PIN Z 1/8" X 2 5/8"
4	32-01-0945	1	PULLEY SUPPORT
5	NC14-63-0001	1	PULLEY PLASTIC 3 1/2" OD X BEARING 3/8"
6	NC01-17-0117	1	HEX. BOLT GR2 ZINC 3/8-16 X 1 3/4"
7	01-01-2485	1	FLAT WASHER
8	NC02-32-0012	3	LOCK WASHER ZINC 3/8"
9	NC02-07-0018	3	HEX. NUT ZINC 3/8-16
10	NC01-04-0002	4	CARR. BOLT GR2 ZINC 1/4-20 X 5/8"
11	NC01-96-0009	5	NYLON-INSERT LOCKNUT ZINC 1/4-20
12	32-55-0070	1	DEFLECTOR CABLE
13	NC02-25-0007	1	WASHER ZINC 0.281 = 9/32
14	32-22-5600	4	BRACKET FOR CABLE
15	NC02-40-0082	4	MACHINE SCREW PHILLIPS ZINC 10-24 OU 3/16"
16	NC01-96-0006	4	NYLON NUT ZINC 10-24
17	32-57-0065	1	CABLE SUPPORT
18	NC01-17-0116	2	BOLT HEX. GR2 ZINC 3/8-16 X 1 1/2"

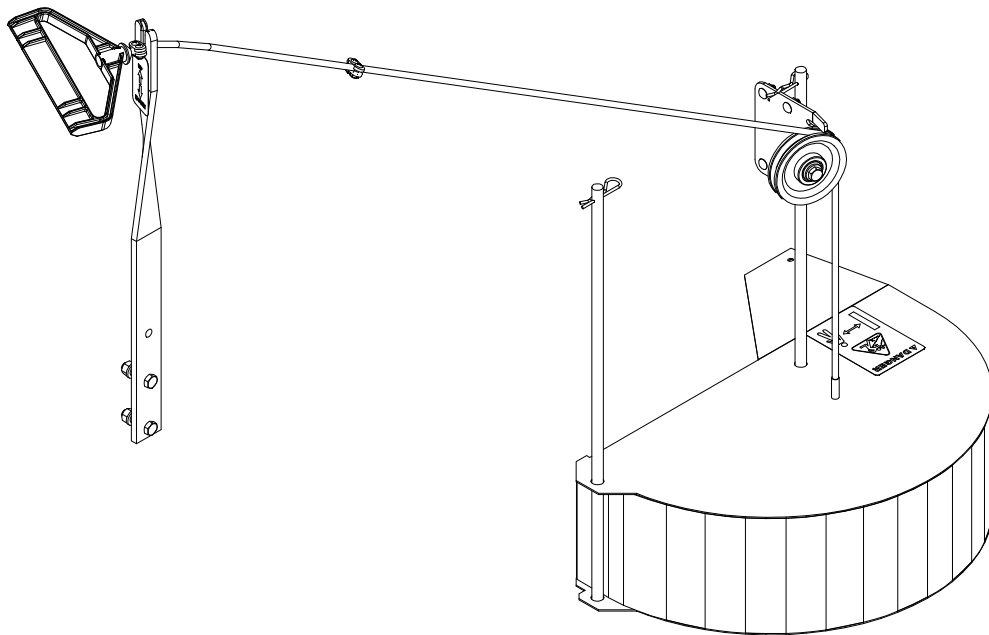

<b>AGRIMETAL</b>			
<b>ASSEMBLY 180° DEFLECTOR</b>			
CREATION : 2016-06-20	ASSEMBLY :	32-57-0090	
REVISION : 2017-12-22	AUTHOR : F.H.	Page 11 de 14	

#	PART #	Qty	TITLE
1	NC01-78-0002	1	3 POINTS PIN 1/8-14 X 5 1/4"
2	09-04-0050	1	PNO 3/16" X 1 49/64" DIA. X Ø 7/8" FLAT WASHER

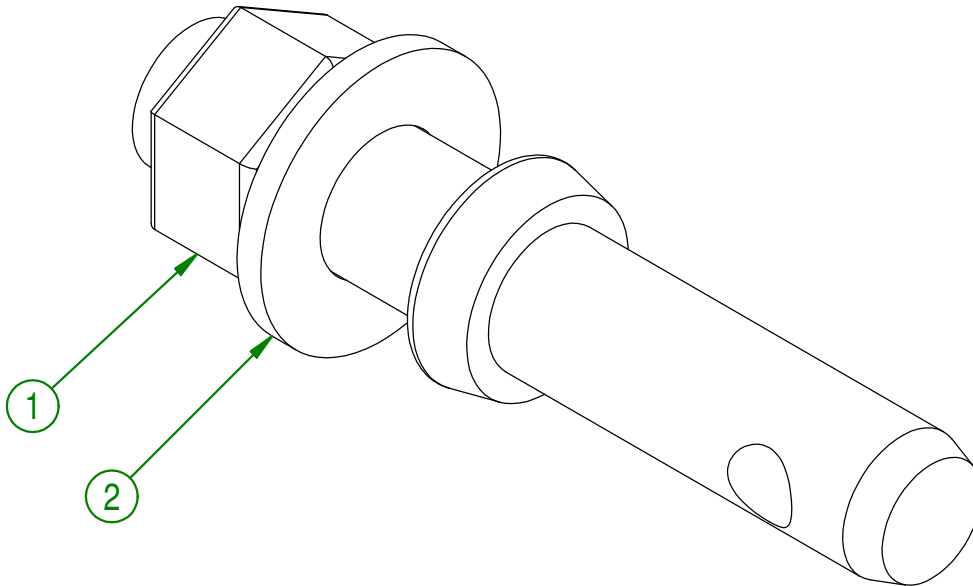

<b>AGRIMETAL</b>	
<b>ASSEMBLY 3 POINTS PIN</b>	
CREATION : 07/02/17	ASSEMBLY : <b>32-57-0095</b>
REVISION : 21/12/17	AUTHOR : F.HÉLIE Page 12 de 14

#	PART #	Qty	TITLE
1	NCI3-30-0237	1	PLASTIC TUBE FOR OPERATOR'S MANUAL
2	NC02-25-0007	3	WASHER ZINC 0.281 = 9/32
3	NC01-96-0009	3	NYLON-INSERT LOCKNUT ZINC 1/4-20
4	NC01-04-0003	3	BOLT CARR. GR2 ZINC 1/4-20 X 3/4"
5	32-98-0620	1	OPER. MAN BW I600 3 POINTS

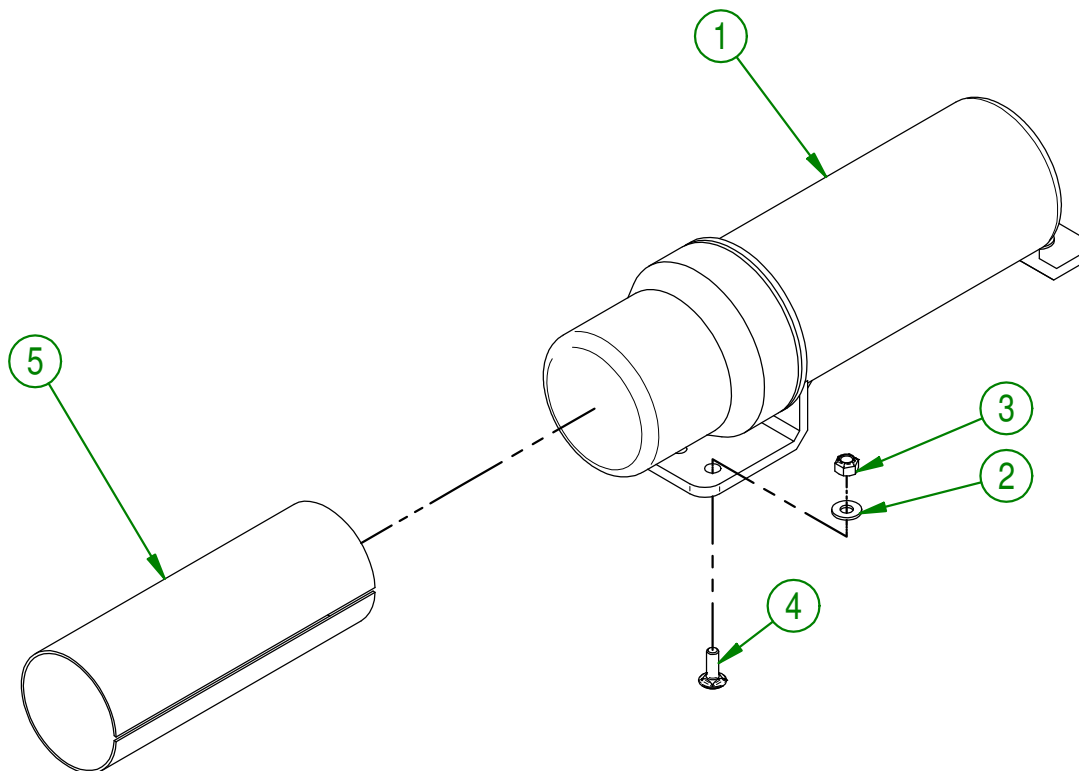

**AGRIMETAL**  
OPERATOR MANUEL

CREATION : 07/02/17  
REVISION : 28/12/17

ASSEMBLY : **32-57-0105**

AUTHOR : F.HÉLIE Page 13 de 14

#	# DE PIÈCE	Qty	TITLE
1	NCI3-33-0157	2	STICKER 1600
2	NCI3-33-0024	6	STICKER GREASE HERE
3	NCI3-33-0035	2	STICKER AGRIMETAL
4	NCI3-33-0163	1	STICKER LOW DECIBEL
5	NCI3-33-0186	1	STICKER (DANGER)
6	NCI3-33-0290	1	STICKER DANGER
7	NCI4-85-0276	1	STICKER (DANGER-PLASTIC GUARD)
8	NCI3-33-0339	1	STICKER 83 DB
9	NCI3-33-0192	2	STICKER (PROJECTION RISK)
10	NCI3-33-0183	1	STICKER CAUTION OPERATION MANUAL
11	NCI3-33-0287	1	STICKER WARNING
12	NCI3-33-0179	1	STICKER IMPORTANT GREASE DRIVE LINE
13	NCI3-33-0298	2	STICKER PULL THIS WAY TO OPEN
14	NCI3-33-0005	1	STICKER MAXIMUM 540 RPM
15	NCI3-33-0187	1	STICKER DANGER (PTO AND PERSON)
16	NCI3-33-2686	1	STICKER IMPORTANT
17	NCI3-33-0133	1	STICKER DUCT POSITION UP DOWN

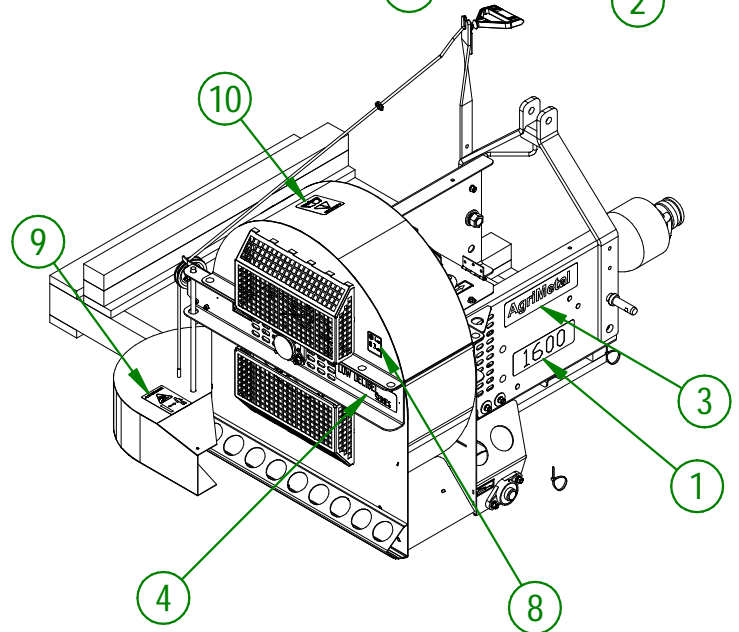
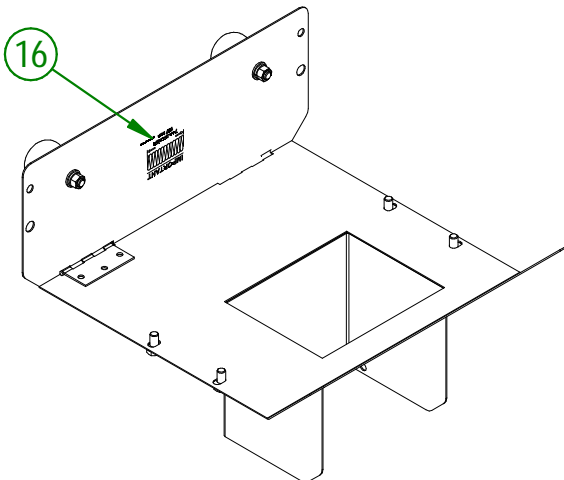
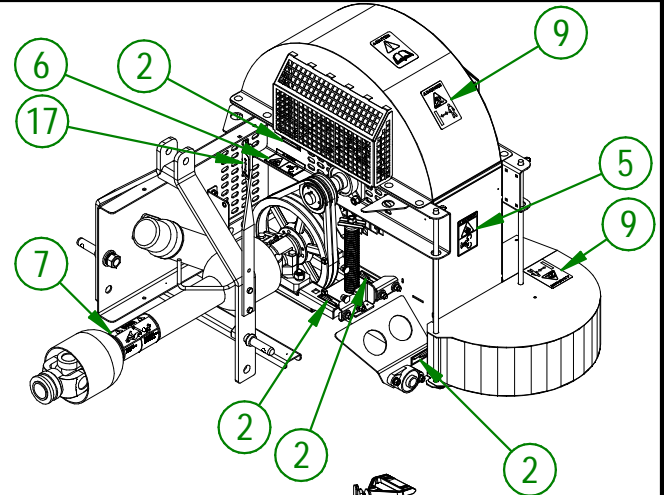
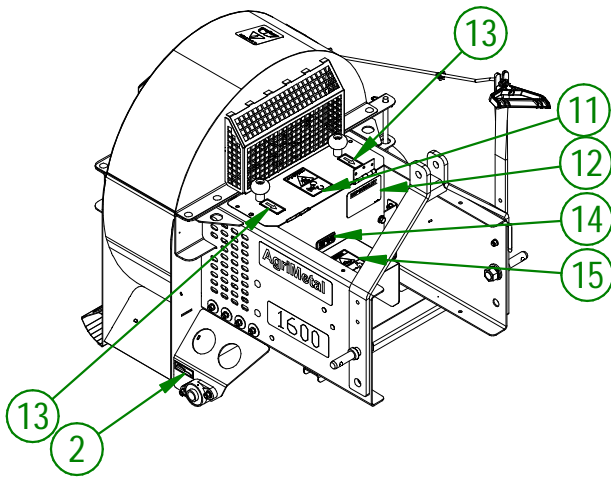

AGRIMETAL		
BW 1600 3 POINTS		
CREATION : 2016-06-20	ASSEMBLY :	32-99-0000
REVISION : 2025-04-30	AUTHOR :	