

# AgriMetal

## PARTS LIST

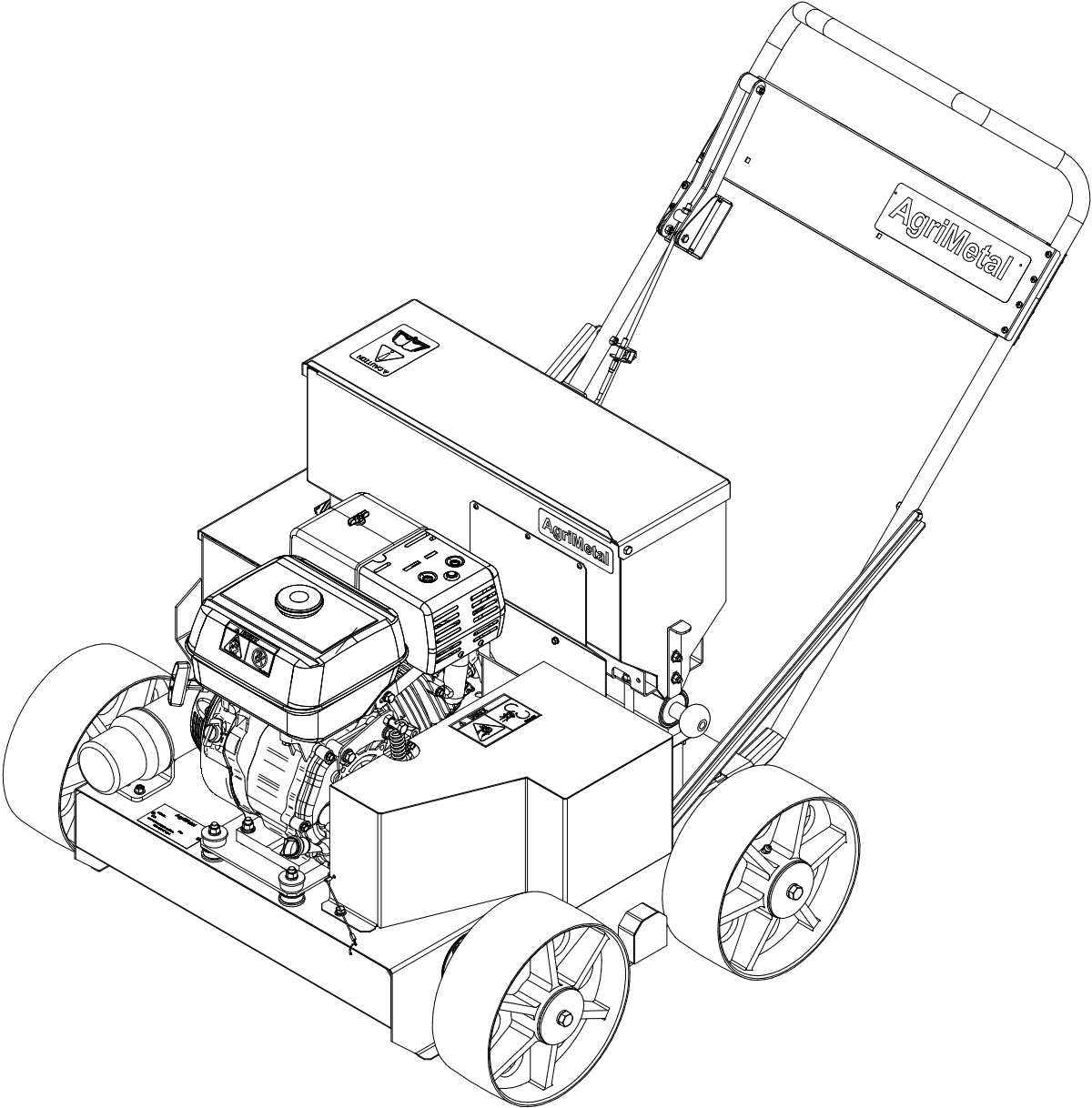

# OVERSEEDER-B

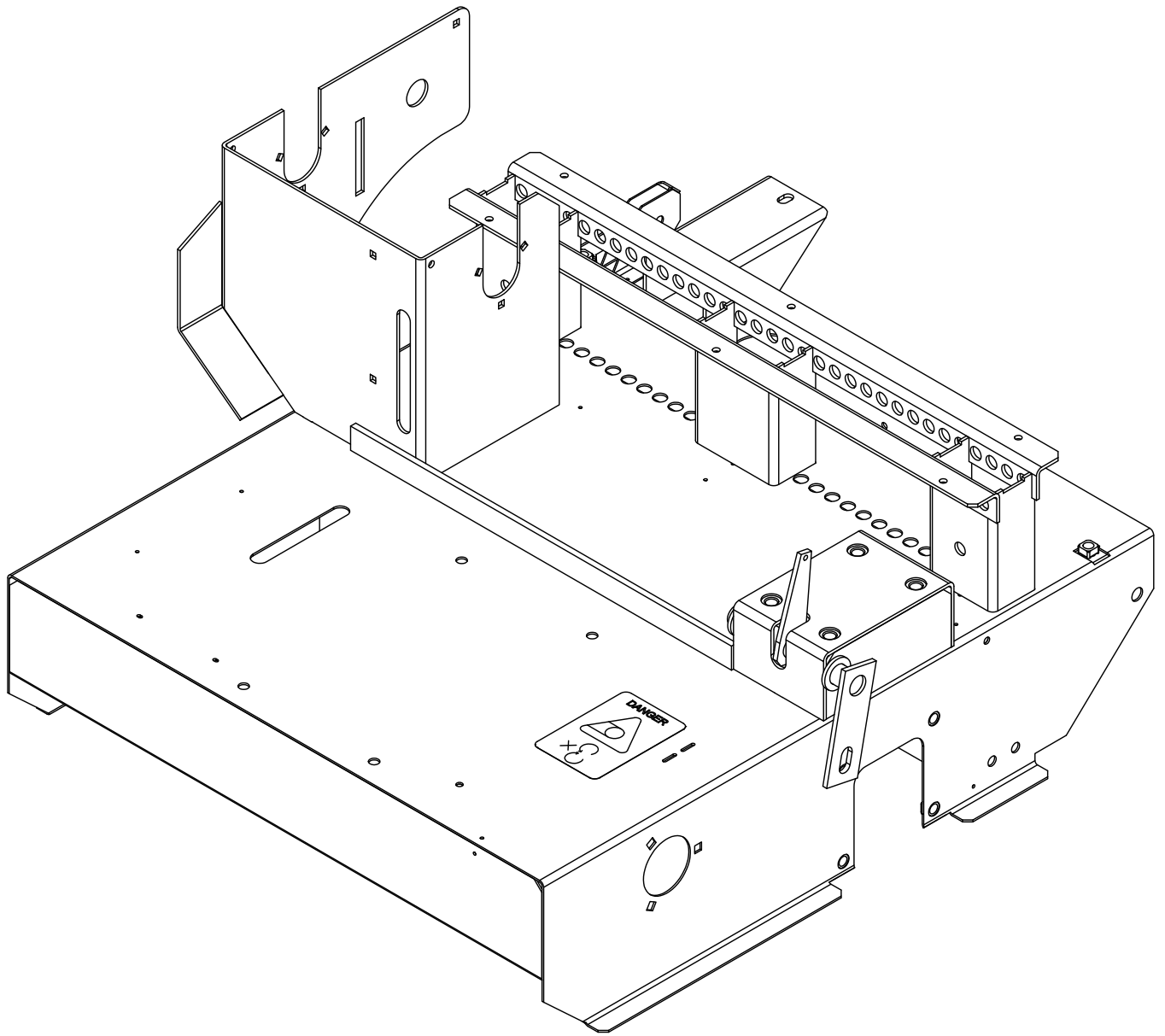

<b>AGRIMETAL</b>			
FRAME GROUP (STICKER INCLUDED)			
CREATION : 01/03/19	ASSEMBLY :	<b>75-57-0000</b>	
REVISION : 01/03/19	AUTHOR : F.HÉLIE	Page 1 de 35	

#	PART #	Qty	TITLE
1	75-42-0195	1	BRUSH 3/4" X 3/4" X 25 1/4" LG.
2	NC02-36-0136	8	FLAT HEAD MACHINE SCREW (SQUARE DRIVE) 1/4-20 X 1 1/4"
3	75-21-0200	34	SEED DISPENSER
4	75-42-0625	33	SEED DISPENSER WASHER
5	75-13-0405	1	SEED DISPENSER WHEEL ROD
6	75-13-0410	2	SEED DISPENSER ROD
7	01-01-2485	6	FLAT WASHER 14 GA X 13/16"OD X 25/64" ID
8	NC01-96-0011	6	NYLON NUT 3/8-16

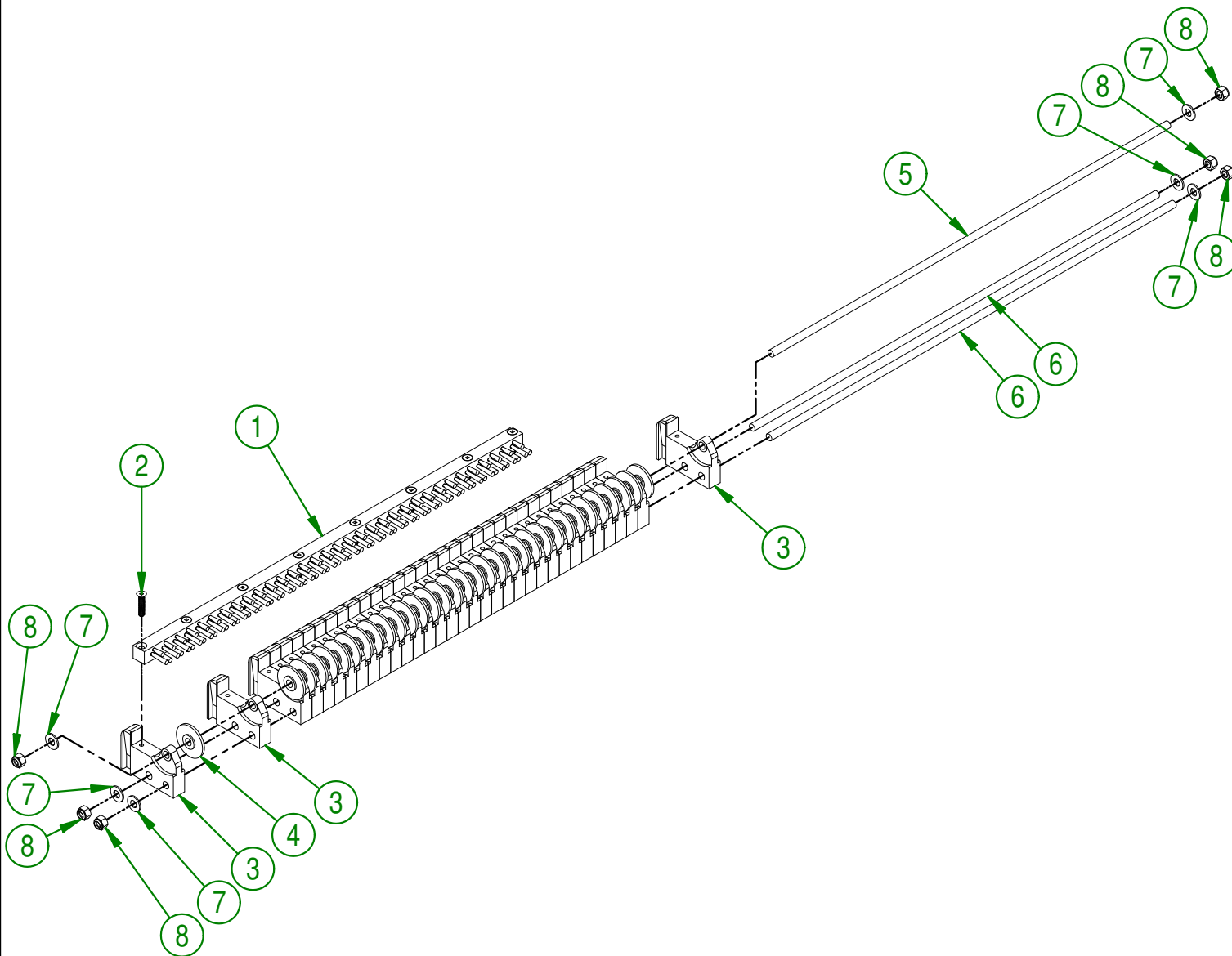

<b>AGRIMETAL</b>	
<b>SEED DISPENSER ASSEMBLY</b>	
CREATION : 01/03/19	ASSEMBLY : <b>75-55-0015</b>
REVISION : 01/03/19	AUTHOR : F.HÉLIE   Page 2 de 35

75-57-0010

#	PART #	Qty	TITLE
1	75-20-0105	1	FRONT WHEEL SHAFT
2	NC14-75-0009	4	PRESSED STEEL FLANGED HOUSING F5 O.D. 3 3/4"
3	NC14-75-0016	2	SEAL BALL BEARING SB 205-16
4	NC01-04-0055	6	CARR. BOLT GR2 ZINC 5/16-18 X 5/8"
5	NC02-14-0006	6	HEX. NUT SPECIAL FLANGET NC 5/16-18 B GRADE
6	NC01-65-0087	1	KEY 1/4 X 1/4 X 1 1/2"
7	NC14-55-0244	1	SPROCKET 35BI5H X Ø 1" KW 1/4" 2SS

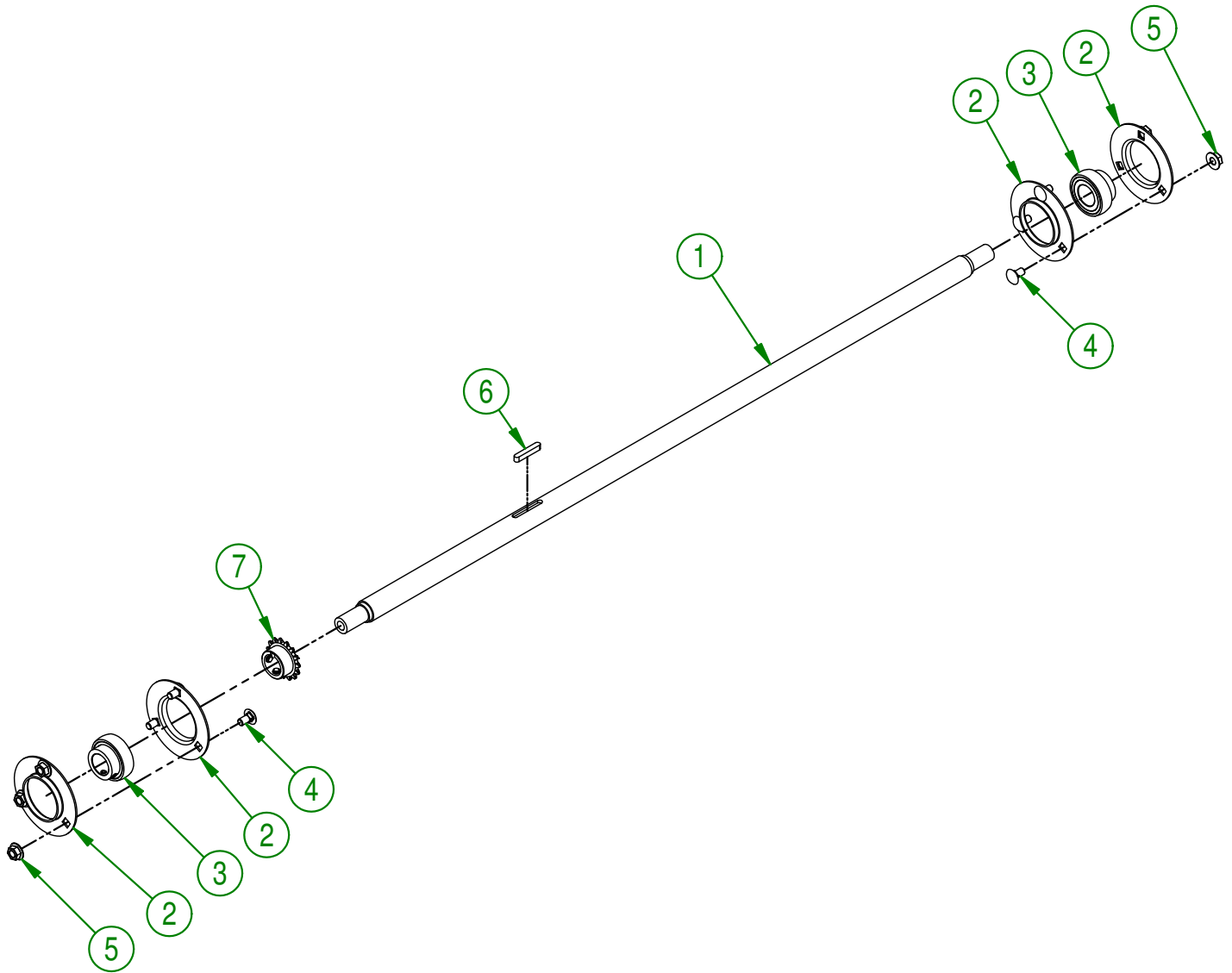

<b>AGRIMETAL</b>	
<b>FRONT WHEEL SHAFT GROUP</b>	
CREATION : 01/03/19	ASSEMBLY : <b>75-57-0010</b>
REVISION : 01/03/19	AUTHOR : F.HÉLIE   Page 3 de 35

75-57-0015

#	PART #	Qty	TITLE
1	75-55-0060	1	FRONT U.H.M.W. BLACK WHEEL
2	75-42-0140	1	LEFT FRONT WHEEL BUSHING
3	75-01-0900	1	WASHER
4	75-01-0902	1	WASHER
5	NC02-32-0014	1	LOCK WASHER ZINC 1/2"
6	NC01-17-0247	1	HEX. BOLT GR2 ZINC 1/2-13 X 1"

75-55-0060

#	PART #	Qty	TITLE
7	75-55-0050	1	U.H.M.W. BLACK WHEEL
8	75-42-0100	1	PLASTIC WHEEL INTERNAL BUSHING
9	75-21-0020	1	PLASTIC WHEEL INTERNAL BUSHING
10	NC14-75-0112	2	NEEDLE BEARING RC-121610
11	NC14-70-0027	1	ROLLER BEARING

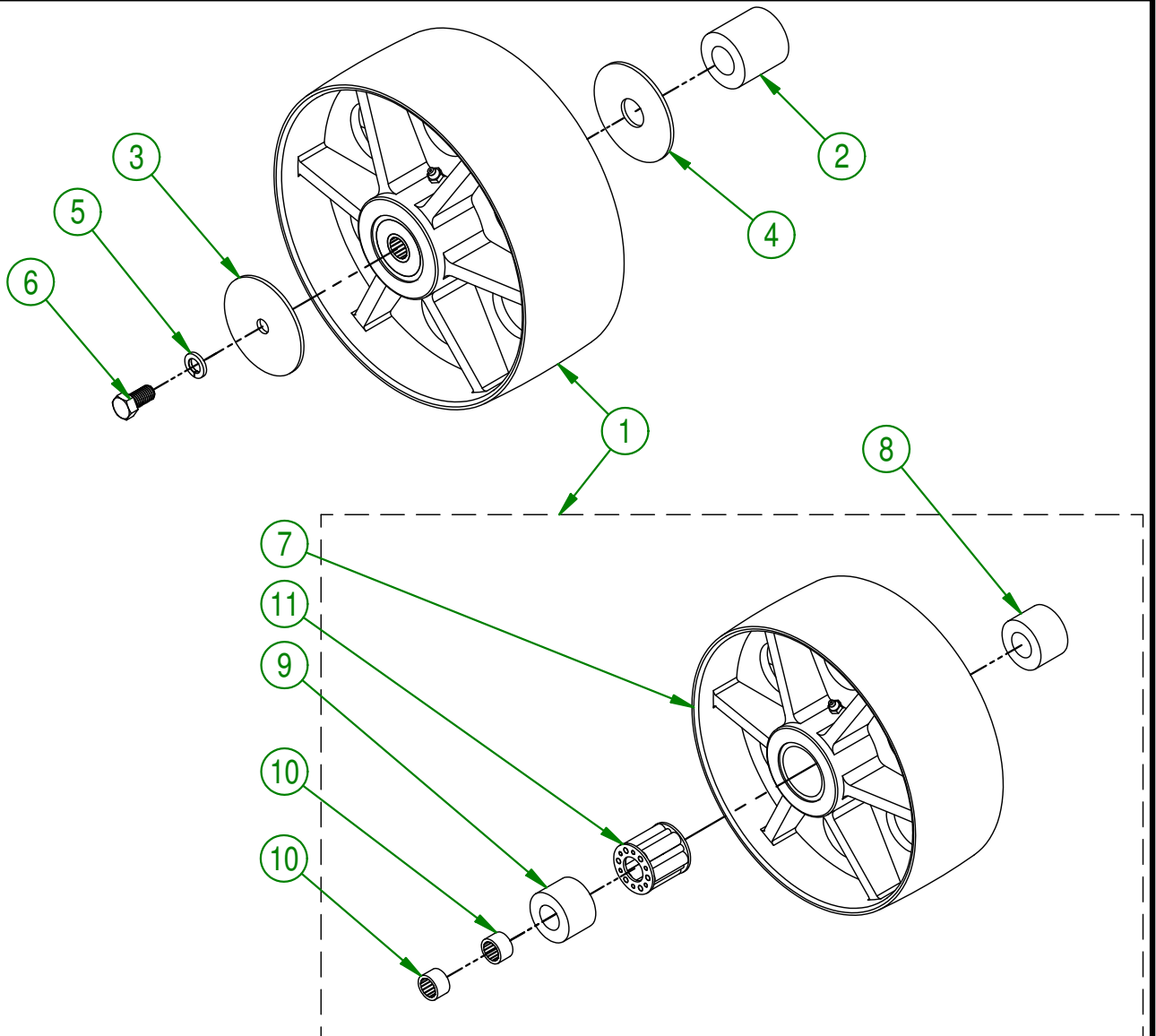

**AGRIMETAL**

**LEFT FRONT WHEEL GROUP**

CREATION : 01/03/19  
 REVISION : 01/03/19

ASSEMBLY : **75-57-0015**

AUTHOR : F.HÉLIE

Page 4 de 35

75-57-0020

#	PART #	Qty	TITLE
1	75-55-0060	1	FRONT U.H.M.W. BLACK WHEEL
2	NC02-32-0014	1	LOCK WASHER ZINC 1/2"
3	NC01-17-0247	1	HEX. BOLT GR2 ZINC 1/2-13 X 1"
4	75-42-0150	1	RIGHT FRONT WHEEL WASHER
5	75-01-0900	1	WASHER
6	75-01-0902	1	WASHER

75-55-0060

#	PART #	Qty	TITLE
7	75-55-0050	1	U.H.M.W. BLACK WHEEL
8	75-42-0100	1	PLASTIC WHEEL INTERNAL BUSHING
9	75-21-0020	1	PLASTIC WHEEL INTERNAL BUSHING
10	NC14-75-0112	2	NEEDLE BEARING RC-121610
11	NC14-70-0027	1	ROLLER BEARING

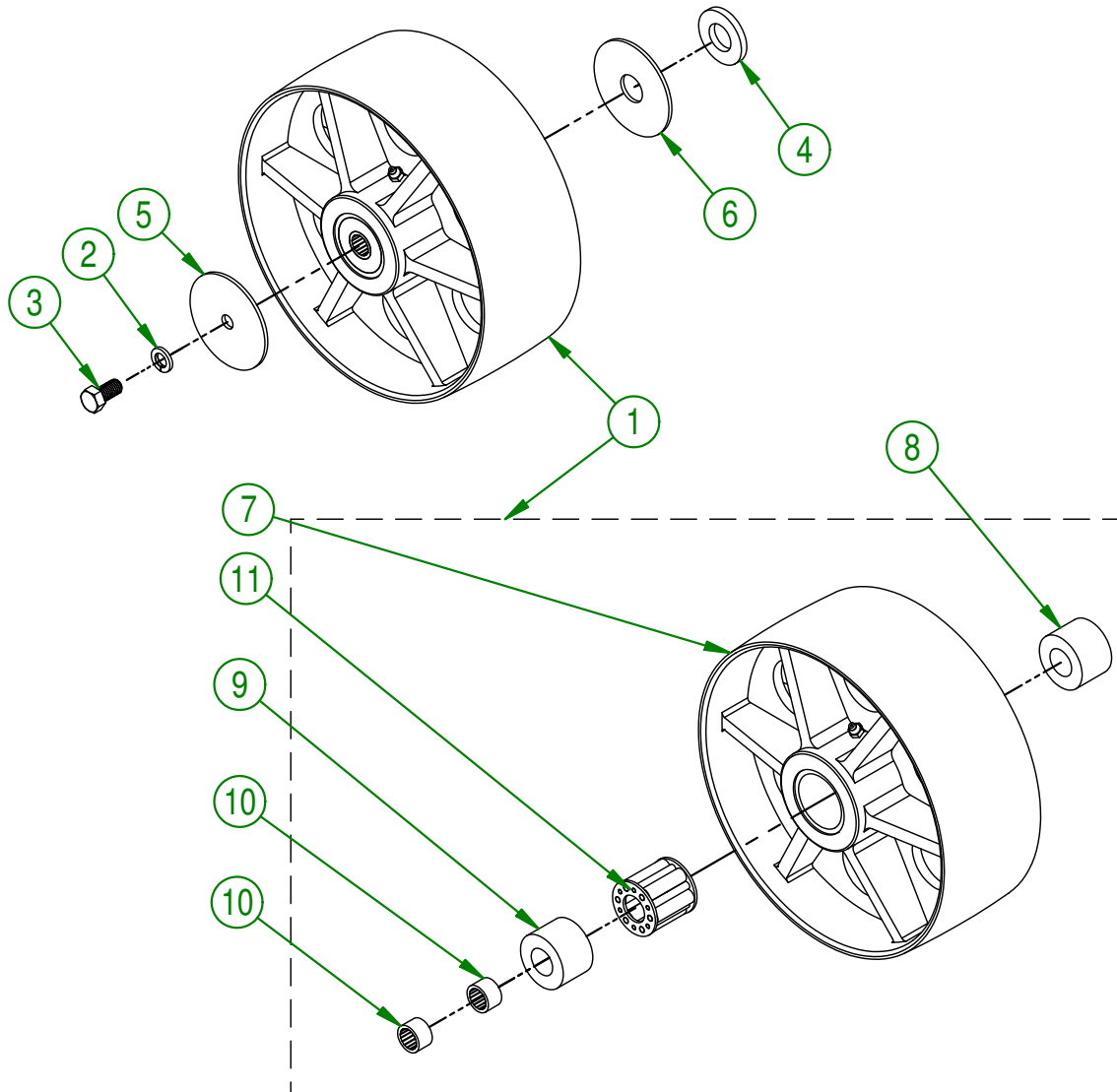

**AGRIMETAL**  
**RIGHT FRONT WHEEL GROUP**

CREATION : 01/03/19  
 REVISION : 01/03/19

ASSEMBLY : **75-57-0020**

AUTHOR : F.HÉLIE

Page 5 de 35

#	PART #	Qty	TITLE
1	NCI3-80-0238	1	PROFILE h-TYPE FOR BRUSH #7 X 24" LG.
2	NCI3-80-0236	1	BLACK NYLON BRUSH .030 X 1 1/2" X 25"
3	NC01-78-0016	8	ALUMINIUM BLIND POP RIVET STEEL MANDREL 0.187 X 0.690

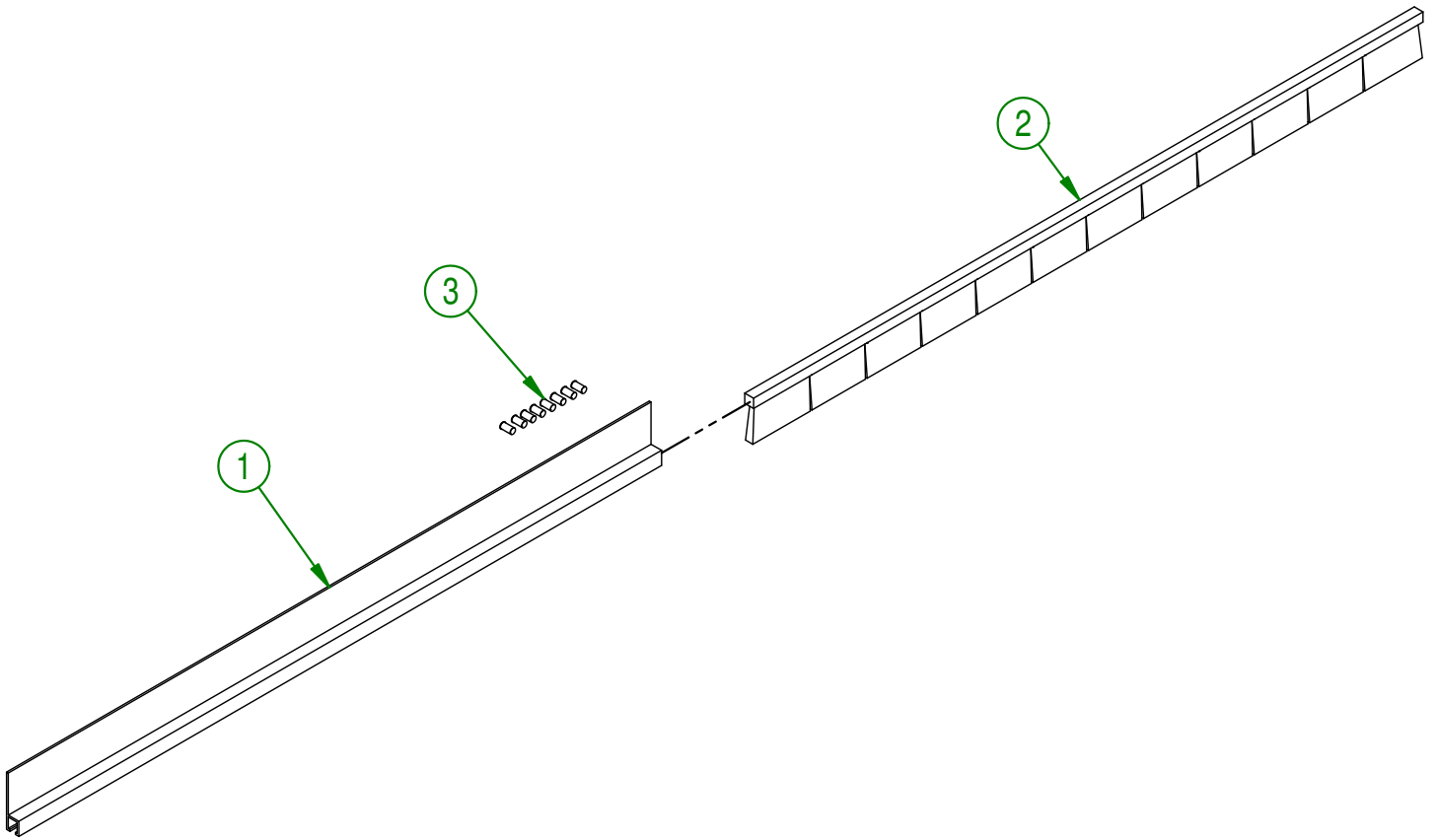

<b>AGRIMETAL</b>	
BRUSH 1 1/2" GROUP (FRONT)	
CREATION : 01/03/19	ASSEMBLY : <b>75-57-0025</b>
REVISION : 01/03/19	AUTHOR : F.HÉLIE
	Page 6 de 35

#	PART #	Qty	TITLE
1	75-50-0025	1	ADJUSTABLE WHEEL FRAME
2	NC01-17-0253	2	HEX. BOLT GR2 ZINC 1/2-13 X 2 1/2"
3	NC02-25-0011	6	WASHER SAE ZINC 17/32 ID
4	NC02-32-0014	2	LOCK WASHER ZINC 1/2"
5	NC01-96-0014	2	NYLON-INSERT LOCKNUT ZINC 1/2-13
6	01-01-1660	2	WASHER SPACER

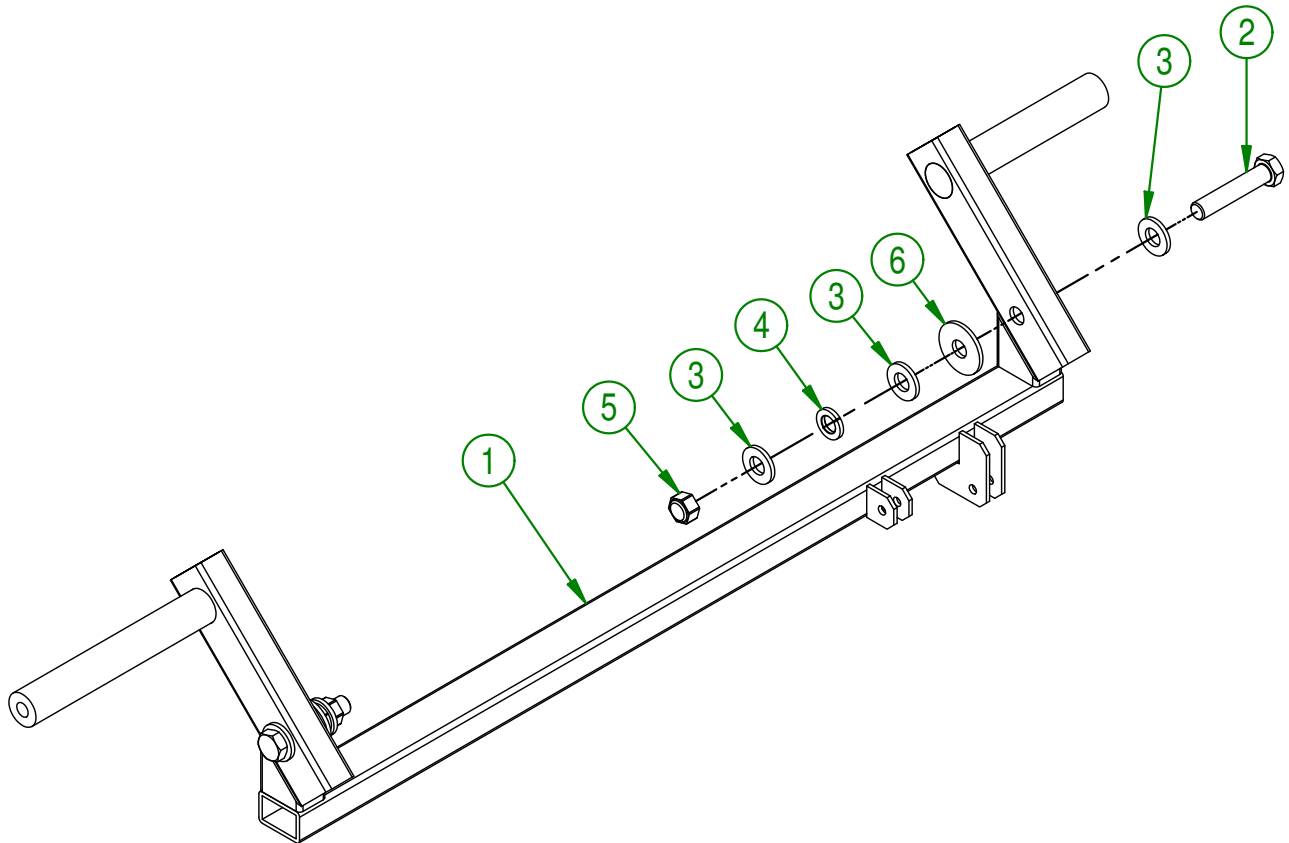
**AGRIMETAL****ADJUSTABLE WHEEL FRAME GROUP**

CREATION : 01/03/19  
 REVISION : 01/03/19

ASSEMBLY : **75-57-0030**

AUTHOR : F.HÉLIE

Page 7 de 35

75-57-0035

#	PART #	Qty	TITLE
1	75-55-0055	1	REAR U.H.M.W BLACK WHEEL
2	75-42-0145	1	LEFT REAR WHEEL BUSHING
3	75-01-0900	1	WASHER
4	75-01-0902	1	WASHER
5	NC02-32-0014	1	LOCK WASHER ZINC 1/2"
6	NC01-17-0247	1	HEX. BOLT GR2 ZINC 1/2-13 X 1"

75-55-0055

#	PART #	Qty	TITLE
7	75-55-0050	1	U.H.M.W. BLACK WHEEL
8	NC14-70-0027	1	ROLLER BEARING
9	75-42-0100	2	PLASTIC WHEEL INTERNAL BUSHING

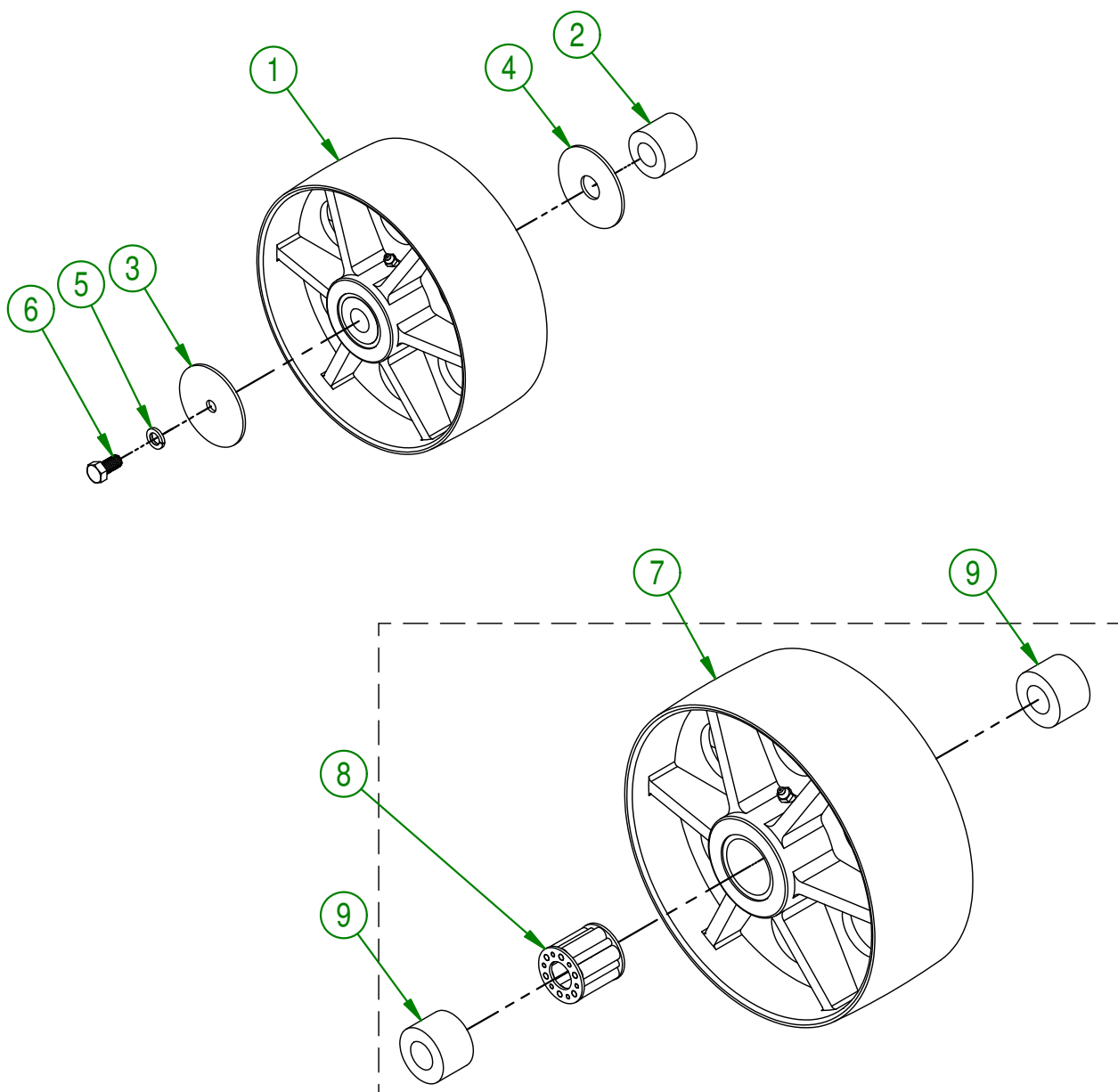

**AGRIMETAL**  
LEFT REAR WHEEL GROUP

CREATION : 01/03/19  
REVISION : 01/03/19

ASSEMBLY : **75-57-0035**

AUTHOR : F.HÉLIE

Page 8 de 35

75-57-0040

#	PART #	Qty	TITLE
1	75-55-0055	1	REAR U.H.M.W BLACK WHEEL
2	NC02-32-0014	1	LOCK WASHER ZINC 1/2"
3	NC01-17-0247	1	HEX. BOLT GR2 ZINC 1/2-13 X 1"
4	75-01-0900	1	WASHER

75-55-0055

#	PART #	Qty	TITLE
5	75-55-0050	1	U.H.M.W. BLACK WHEEL
6	NC14-70-0027	1	ROLLER BEARING
7	75-42-0100	2	PLASTIC WHEEL INTERNAL BUSHING

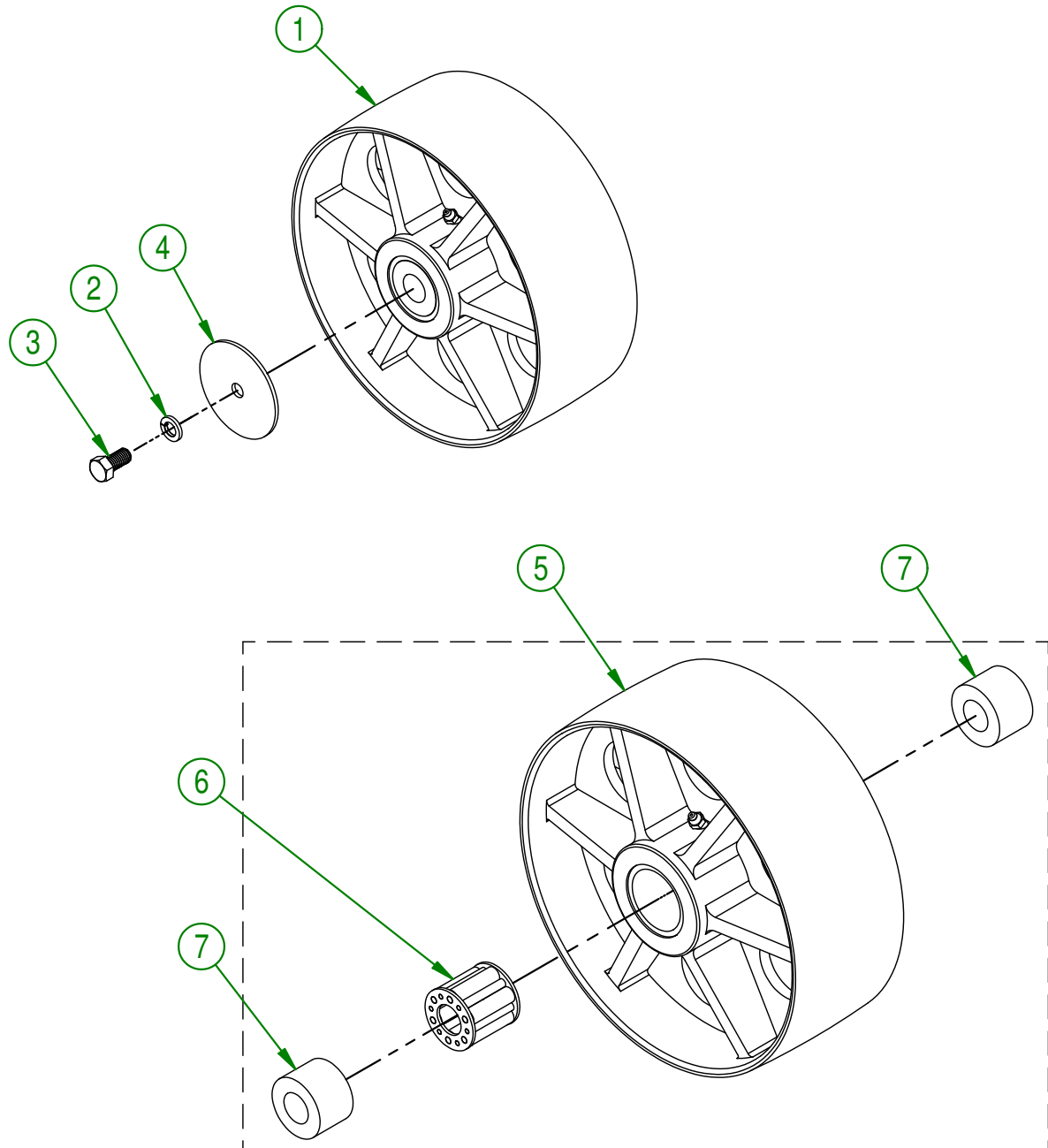

**AGRIMETAL**  
**RIGHT REAR WHEEL GROUP**

CREATION : 01/03/19  
 REVISION : 01/03/19

ASSEMBLY : **75-57-0040**  
 AUTHOR : F.HÉLIE

#	PART #	Qty	TITLE
1	75-01-7640	1	HANDLE BRACE
2	NC01-17-0004	1	HEX. BOLT GR2 ZINC 1/4-20 X 3/4"
3	NC02-25-0007	1	WASHER ZINC 0.281 = 9/32
4	NC01-96-0009	2	NYLON-INSERT LOCKNUT ZINC 1/4-20
5	NC01-17-0008	1	HEX. BOLT GR2 ZINC 1/4-20 X 1 1/2"
6	NC01-17-0007	1	HEX. BOLT GR2 ZINC 1/4-20 X 1 1/4"
7	NC02-32-0010	1	LOCK WASHER ZINC 1/4"

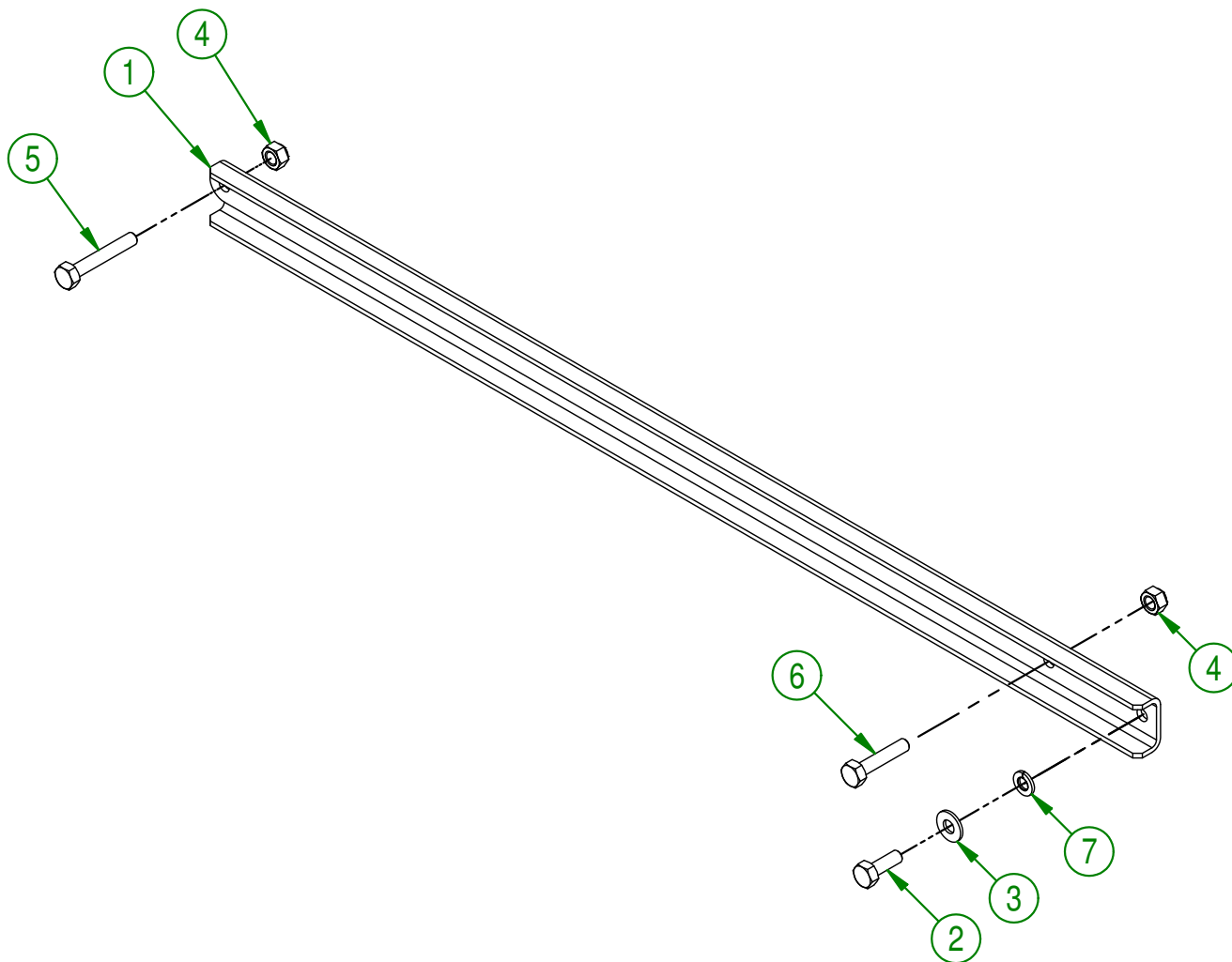

<b>AGRIMETAL</b>	
<b>HANDLE BRACE GROUP</b>	
CREATION : 01/03/19	ASSEMBLY : <b>75-57-0045</b>
REVISION : 01/03/19	AUTHOR : F.HÉLIE   Page 10 de 35

75-57-0050

#	PART #	Qty	TITLE
1	75-55-0045	1	BRUSH 4" AND SUPPORT (REAR) ASSEMBLY
2	NC02-25-0007	3	WASHER ZINC 0.281 = 9/32
3	NC02-32-0010	3	LOCK WASHER ZINC 1/4"
4	NC01-17-0004	3	HEX. BOLT GR2 ZINC 1/4-20 X 3/4"

75-55-0045

#	PART #	Qty	TITLE
5	75-01-7600	1	REAR BRUSH SUPPORT
6	75-41-7250	1	PROFILE h-TYPE FOR BRUSH #7 X 24" LG
7	NC13-80-0237	1	BLACK NYLON BRUSH .030 X 1 1/2" HAUT X 25"
8	NC01-78-0016	8	ALUMINIUM BLIND POP RIVET STEEL MANDREL 0.187 X 0.690

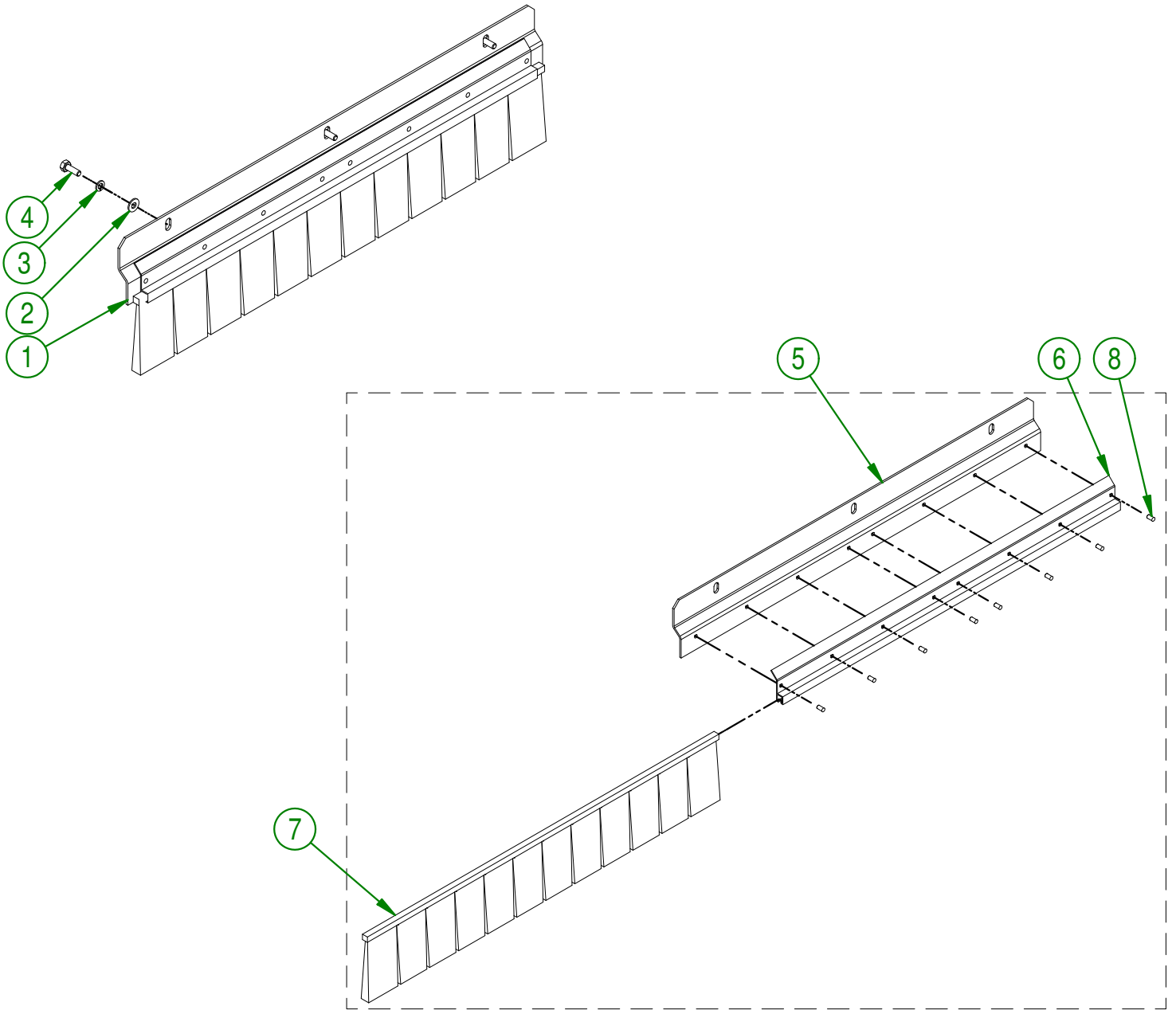

<b>AGRIMETAL</b>	
<b>BRUSH 4" AND SUPPORT GROUP (REAR)</b>	
CREATION : 01/03/19	ASSEMBLY : <b>75-57-0050</b>
REVISION : 01/03/19	AUTHOR : F.HÉLIE Page 11 de 35

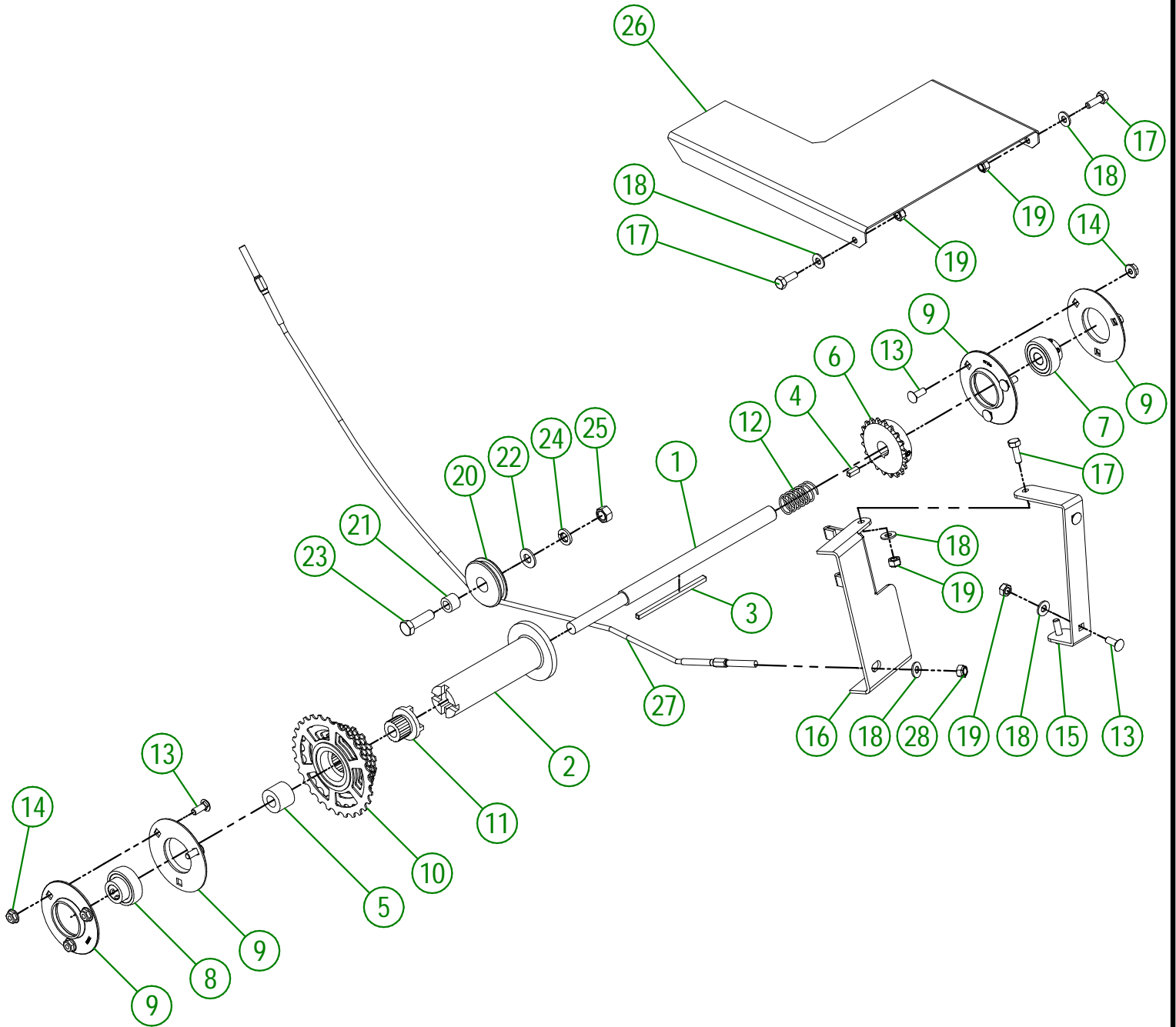

**AGRIMETAL**  
**CLUTCH GROUP**

CREATION : 01/03/19  
 REVISION : 12/05/25

ASSEMBLY : **75-57-0055**  
 AUTHOR : F.HÉLIE

## 75-57-0055

#	PART #	Qty	TITLE
1	75-13-0805	1	CLUTCH SHAFT
2	75-21-0075	1	CLUTCH
3	75-41-0900	1	KEY 3/16" X 3/16" X 4"
4	75-41-0905	1	KEY 3/16" X 3/16" X 9/16"
5	75-42-0160	1	MULTIPLE SPROCKET BUSHING
6	75-36-0102	1	CLUTCH SPROCKET
7	NC14-75-0108	1	BEARING SB 201-8 $\varnothing$ 1/2"
8	NC14-75-0155	1	BEARING SB 202-10 $\varnothing$ 5/8"
9	NC14-75-0136	4	PRESSED STEEL FLANGED HOUSING O.D. 3 3/16" PF203
10	NC14-55-0243	1	MULTIPLE SPROCKET
11	75-13-1800	1	CLUTCH OF CALIBRATED ROLLER
12	NC13-85-0037	1	COMPRESSION SPRING
13	NC01-04-0002	8	CARR. BOLT GR2 ZINC 1/4-20 X 5/8"
14	NC02-14-0017	6	FLANGED NUT GR. B 1/4-20
15	75-01-1545	1	HINGE FOR CLUTCH
16	75-01-1550	1	CLUTCH LEVER
17	NC01-17-0004	4	HEX. BOLT GR2 ZINC 1/4-20 X 3/4"
18	NC02-25-0007	7	WASHER ZINC 0.281 = 9/32
19	NC01-96-0009	6	NYLON-INSERT LOCKNUT ZINC 1/4-20
20	75-29-0000	1	CABLE PULLEY
21	75-09-0005	1	CABLE PULLEY BUSHING
22	01-01-2485	1	FLAT WASHER 14 GA X 13/16"OD X 25/64" ID
23	NC01-17-0115	1	HEX. BOLT GR2 ZINC 3/8-16 X 1 1/4"
24	NC02-32-0012	1	LOCK WASHER ZINC 3/8"
25	NC02-07-0018	1	HEX. NUT ZINC 3/8-16
26	75-01-3045	1	CLUTCH COVER
27	NC17-02-0300	1	OVERSEEDER CABLE ASSEMBLY
28	NC01-97-0004	1	NYLON-INSERT LOCKNUT ZINC 1/4-28

#	PART #	Qty	TITLE
1	75-42-0170	2	CHAIN TENSIONER #35
2	NC01-96-0006	4	NYLON NUT ZINC 10-24
3	NC02-40-0085	4	MACHINE SCREW T.R. 10-24 X 1 1/2"
4	75-37-1000	1	CHAIN #35 X 36"

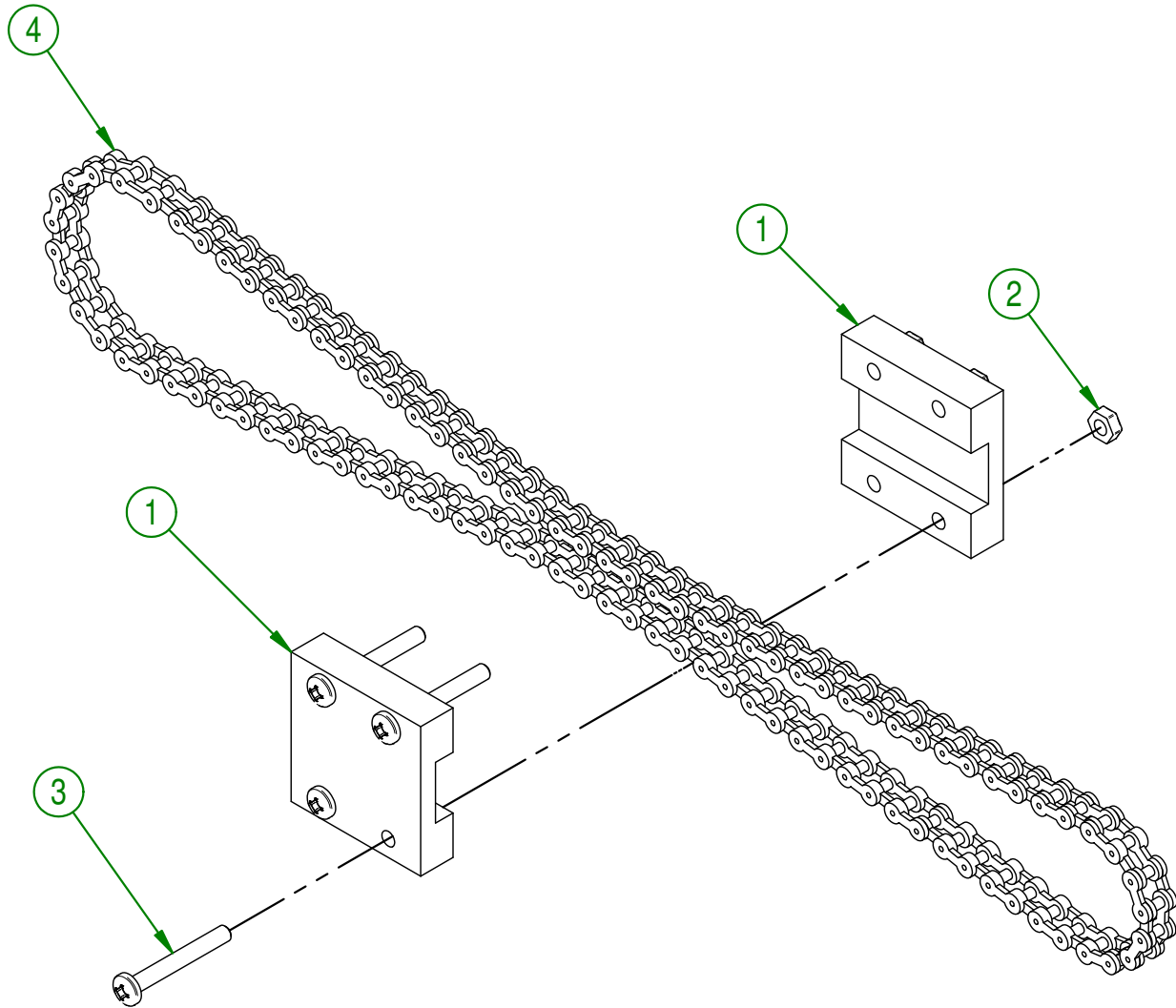
**AGRIMETAL****TENSIONER & ROTOR CLUTCH CHAIN GROUP**

CREATION : 01/03/19  
 REVISION : 01/03/19

ASSEMBLY : **75-57-0080**

AUTHOR : F.HÉLIE Page 14 de 35

75-57-0090

#	PART #	Qty	TITLE
1	75-01-3110	2	DISTRIBUTOR SHAFT SHIM
2	75-09-0015	6	ASSEMBLY GUIDE
3	75-01-7555	1	CLUTCH BOX BRACE
4	NC01-04-0002	3	CARR. BOLT GR2 ZINC 1/4-20 X 5/8"
5	NC01-17-0003	1	HEX. BOLT GR2 ZINC 1/4-20 X 5/8"
6	NC02-25-0007	6	WASHER ZINC 0.281 = 9/32
7	NC02-14-0017	7	FLANGED NUT GR. B 1/4-20
8	NC01-96-0009	3	NYLON-INSERT LOCKNUT ZINC 1/4-20
9	75-01-1560	1	CALIBRATED ROLLER LOCK
10	75-22-2600	1	HEAT SHIELD
11	NC02-40-0080	3	MACHINE SCREWS SQUARE SOCKET #10-24 X 1/2" LG
12	NC01-96-0006	3	NYLON NUT ZINC 3/16
13	NC02-41-0012	1	T METAL HEX. TAPPING SCREW 12 X 1"
14	NC01-17-0020	6	HEX BOLT GR2 NC ZINC 1/4-20 X 4 1/2" LG.

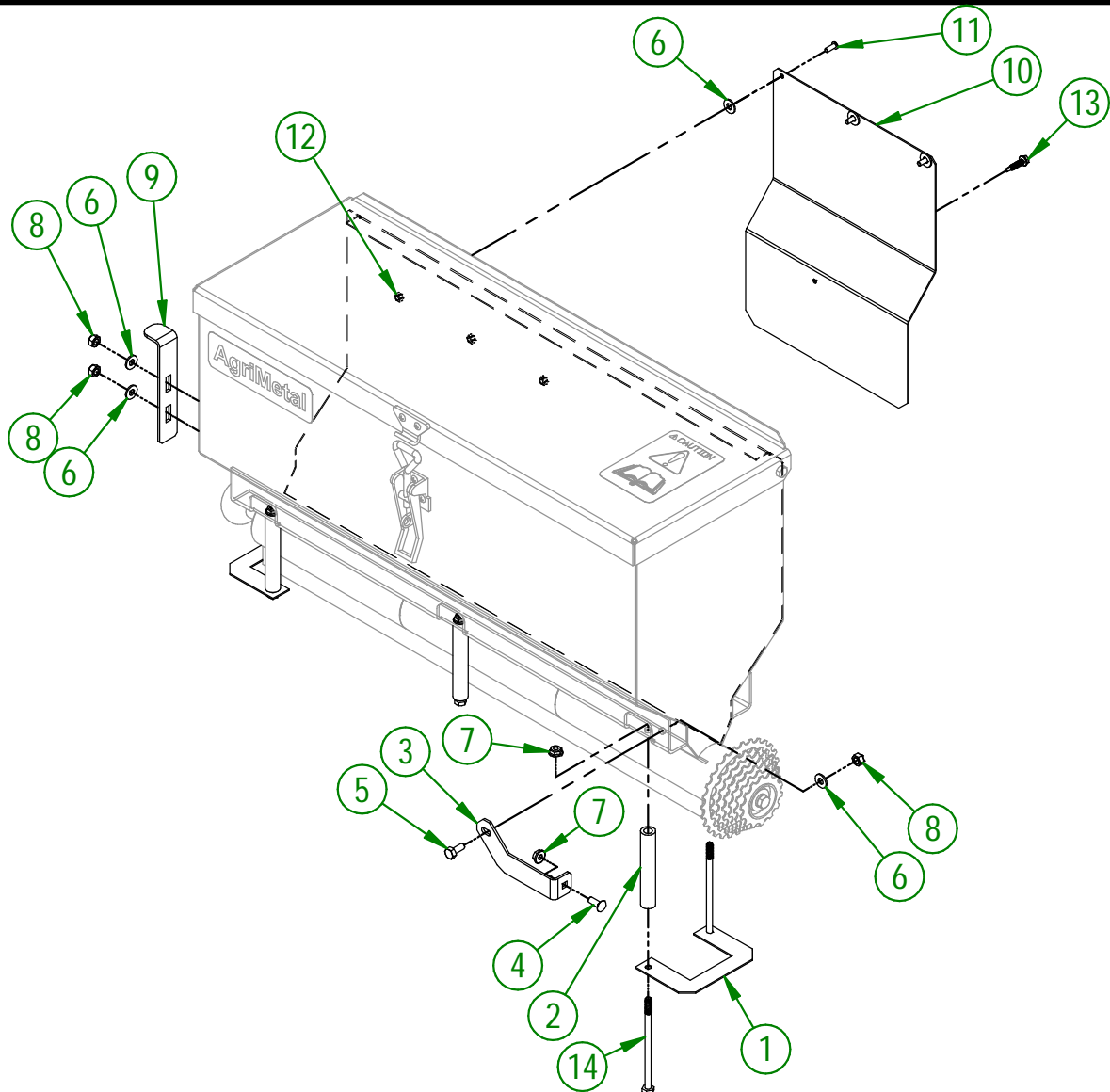

**AGRIMETAL**  
**SEED BOX GROUP**

CREATION : 01/03/19  
REVISION : 26/05/25

ASSEMBLY : **75-57-0090**  
AUTHOR : F.HÉLIE

#	PART #	Qty	TITLE
1	75-57-0095	1	SEED BOX GROUP
2	NC01-63-0036	1	DRAW LATCH 6 1/2"
3	NC01-63-0037	1	DRAW LATCH STRIKER
4	NC02-40-0080	5	MACHINE SCREWS SQUARE SOCKET #10-24 X 1/2" LG
5	NC01-96-0006	5	NYLON NUT ZINC 10-24
6	75-42-0205	2	BLACK ADHESIVE-BACK STRIP
7	75-42-0200	2	BLACK ADHESIVE-BACK STRIP

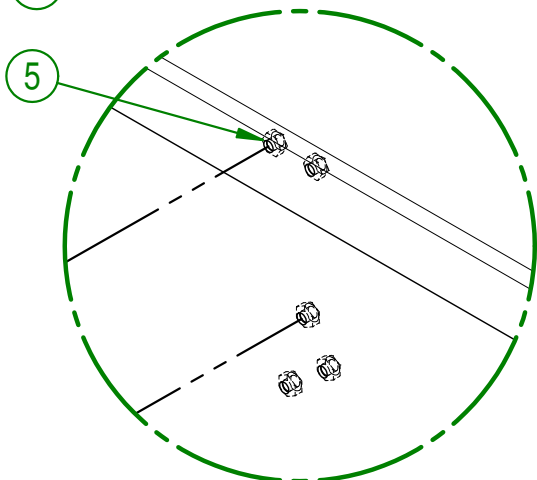
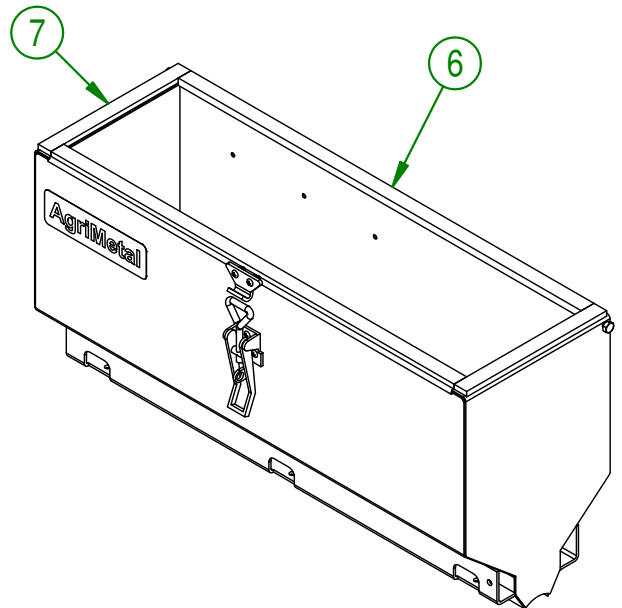
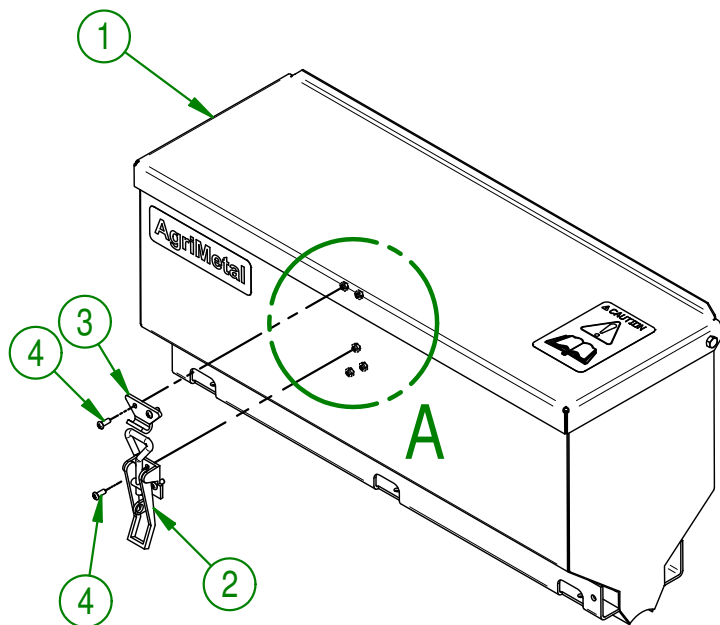

DETAIL A

<b>AGRIMETAL</b>	
SEED BOX ASSEMBLY	
CREATION : 01/03/19	ASSEMBLY : <b>75-55-0090</b>
REVISION : 01/03/19	AUTHOR : F.HÉLIE   Page 16 de 35

#	PART #	Qty	TITLE
1	75-55-0100	1	DISTRIBUTOR TUBE ASSEMBLY
2	NC14-75-0070	2	6205-2RS BEARING
3	NC01-64-0159	1	INTERNAL RETAINING RING 2 1/16" HOLE
4	NC14-55-0243	1	MULTIPLE SPROCKET
5	NC01-25-0058	1	HEX BOLT GR5 ZINC PLATED 5/16-18 X 3/4"
6	NC02-32-0011	1	LOCK WASHER ZINC 5/16"
7	75-13-1600	1	CALIBRATED ROLLER DRIVE SHAFT
8	75-42-0165	1	CALIBRATED ROLLER MULTIPLE SPROCKET BUSHING
9	75-42-0605	1	SEED CALIBRATED ROLLER "BEND"
10	NC02-22-0010	1	WASHER 13/32" ID

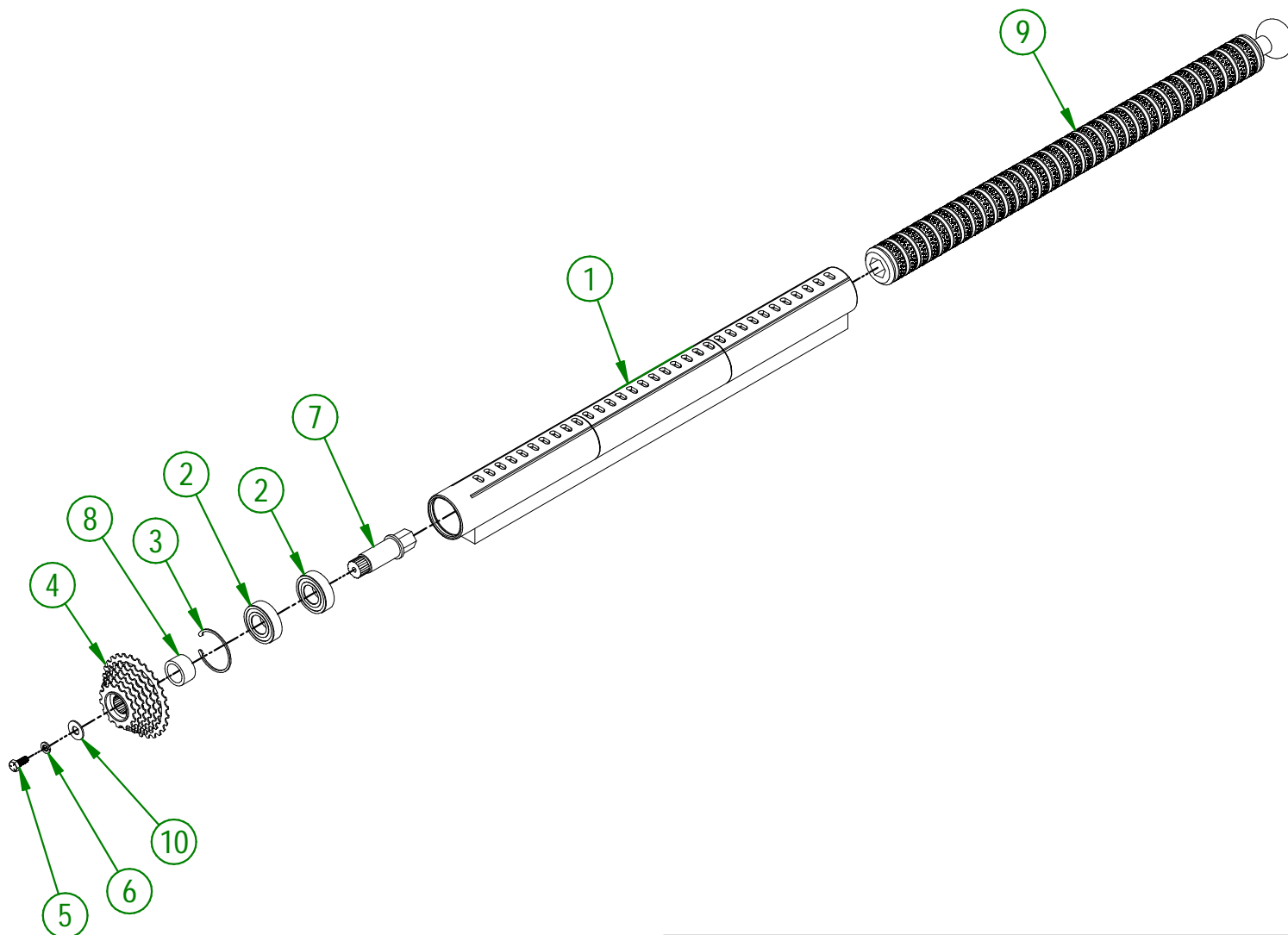

<b>AGRIMETAL</b>	
<b>SEED DISTRIBUTOR TUBE ASSEMBLY</b>	
CREATION : 01/03/19	ASSEMBLY : <b>75-55-0040</b>
REVISION : 19/06/25	AUTHOR : F.HÉLIE

#	PART #	Qty	TITLE
1	75-57-0125	1	CHAIN TENSIONER GROUP
2	75-37-1005	1	BICYCLE CHAIN 22 1/4" ASSEMBLY
3	NC17-46-0018	1	HANDLE KNOB
4	NC02-07-0018	1	HEX. NUT ZINC 3/8-16

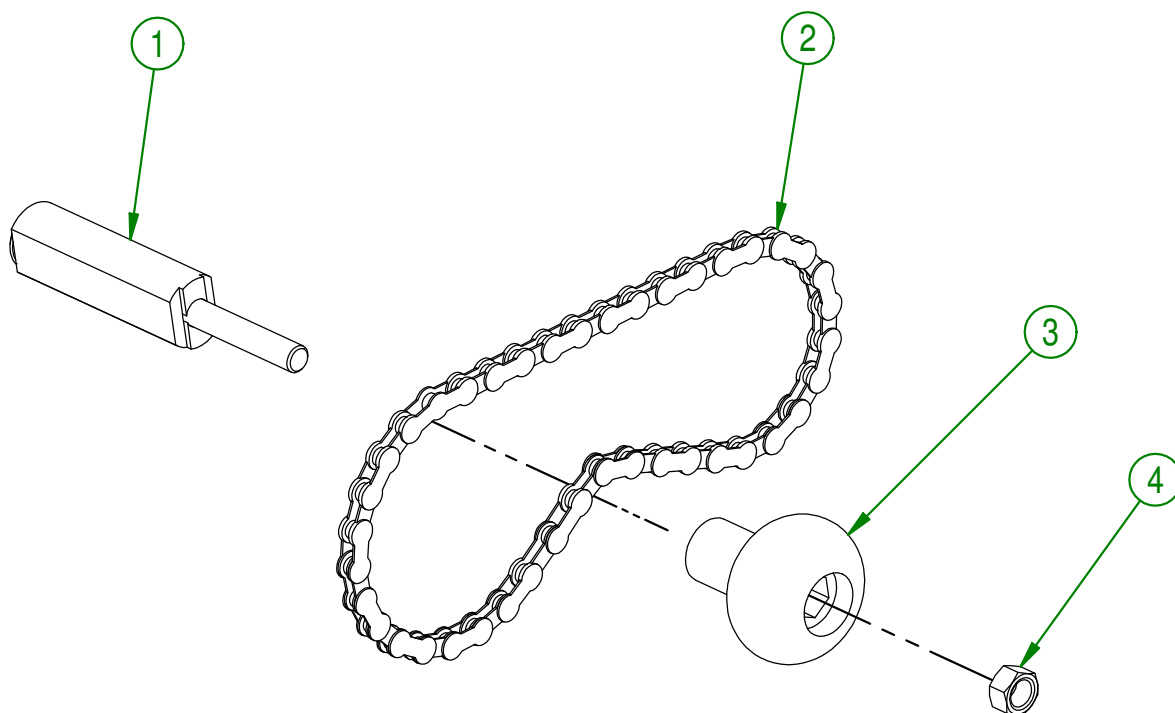
**AGRIMETAL****TENSIONER & MULTIPLE SPROCKET CLUTCH CHAIN GROUP**

CREATION : 01/03/19  
 REVISION : 02/06/20

ASSEMBLY : **75-57-0120**

AUTHOR : F.HÉLIE Page 18 de 35

75-57-0130

#	PART #	Qty	TITLE
1	75-55-0030	1	HANDLE ASSEMBLY
2	NC01-17-0114	2	HEX. BOLT GR2 ZINC 3/8-16 X 1"
3	NC02-07-0018	2	HEX. NUT ZINC 3/8-16

75-55-0030

#	PART #	Qty	TITLE
4	36-55-0015	1	BLACK RUBBER HANDLE ASSEMBLY
5	75-55-0033	1	STRUT (OVERSEEDER STICKER INCLUDED)
6	75-50-0030	1	HANDLE GRIP (LEFT)
7	75-50-0031	1	HANDLE GRIP (RIGHT)
8	36-01-3055	2	HANDLE COUPLING
9	NC02-40-0085	8	MACHINE SCREW T.R. 10-24 X 1 1/2"
10	NC01-96-0006	8	NYLON NUT ZINC 10-24

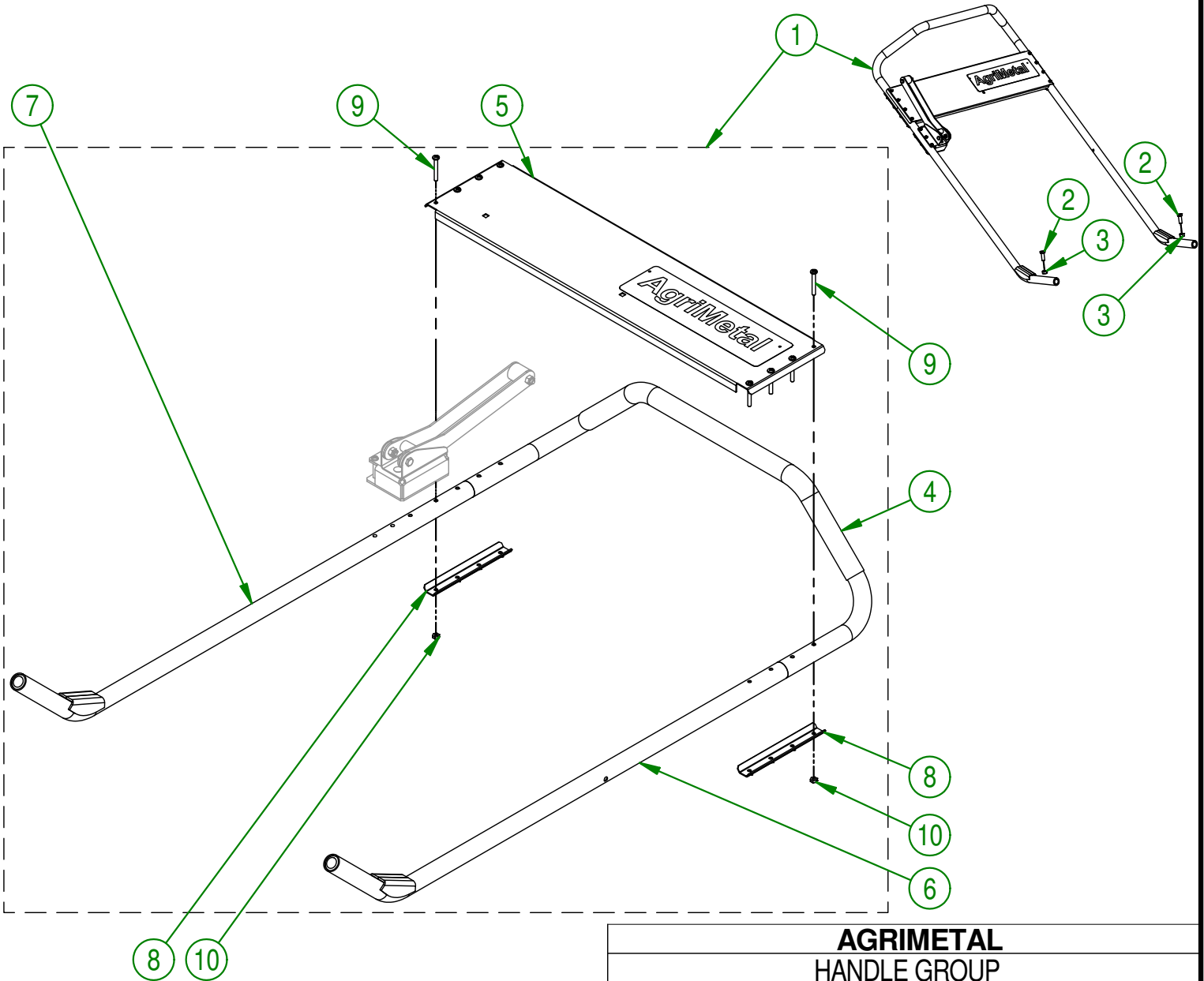

**AGRIMETAL**  
HANDLE GROUP

CREATION : 01/03/19  
REVISION : 01/03/19

ASSEMBLY : **75-57-0130**

AUTHOR : F.HÉLIE | Page 19 de 35

#	PART #	Qty	TITLE
1	75-50-0015	1	RELEASE LEVER SUPPORT
2	NC01-96-0006	3	NYLON NUT ZINC 10-24
3	NC01-04-0001	2	CARR. BOLT GR2 ZINC 1/4-20 X 1/2"
4	NC02-14-0017	2	FLANGED NUT GR. B 1/4-20
5	NC01-17-0008	1	HEX. BOLT GR2 ZINC 1/4-20 X 1 1/2"
6	NC01-96-0009	1	NYLON-INSERT LOCKNUT ZINC 1/4-20
7	NC01-29-0003	2	HEX. BOLT GR5 ZINC 1/4-28 X 5/8"
8	NC01-97-0004	2	NYLON-INSERT LOCKNUT ZINC 1/4-28
9	NC02-40-0085	3	MACHINE SCREW T.R. 10-24 X 1 1/2"
10	75-01-3015	1	LIFT LEVER SUPPORT
11	75-01-7500	1	RELEASE LEVER (LEFT)
12	75-01-7501	1	RELEASE LEVER (RIGHT)
13	75-42-0110	1	LIFT LEVER COUPLING
14	75-42-0105	2	RELEASE LEVER WASHER
15	75-21-0010	1	STEEL CABLE PIVOT

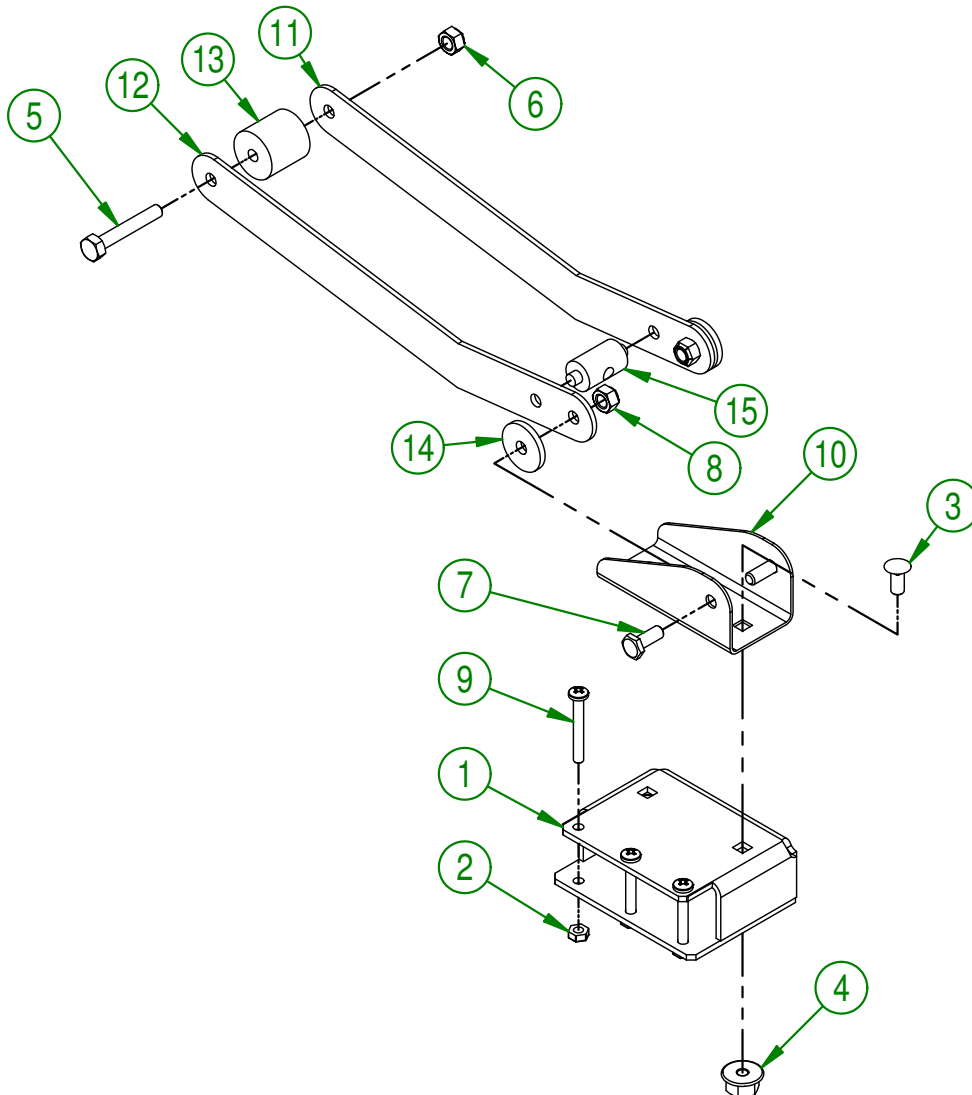
**AGRIMETAL****RELEASE LEVER SUPPORT ASSEMBLY**

CREATION : 01/03/19  
 REVISION : 01/03/19

ASSEMBLY : **75-55-0035**

AUTHOR : F.HÉLIE | Page 20 de 35

75-57-0135

#	PART #	Qty	TITLE
1	75-55-0065	1	CLUTCH ROD ASSEMBLY
2	NC01-17-0006	1	HEX. BOLT 1/4-20 X 1"
3	NC01-96-0009	1	NYLON-INSERT LOCKNUT ZINC 1/4-20
4	75-50-0020	1	CLUTCH ADJUSTABLE CABLE COLAR
5	NC01-17-0112	1	HEX. BOLT GR2 ZINC 3/8-16 X 3/4"
6	NC01-97-0004	1	NYLON-INSERT LOCKNUT ZINC 1/4-28

75-55-0065

#	PART #	Qty	TITLE
7	75-13-0100	1	CLUTCH ROD
8	NC02-10-0016	1	HEX LOCKNUT NF ZINC 1/4-28
9	NC01-67-0102	1	INTERNALLY THREADED BALL JOINT ROD END 1/4-28

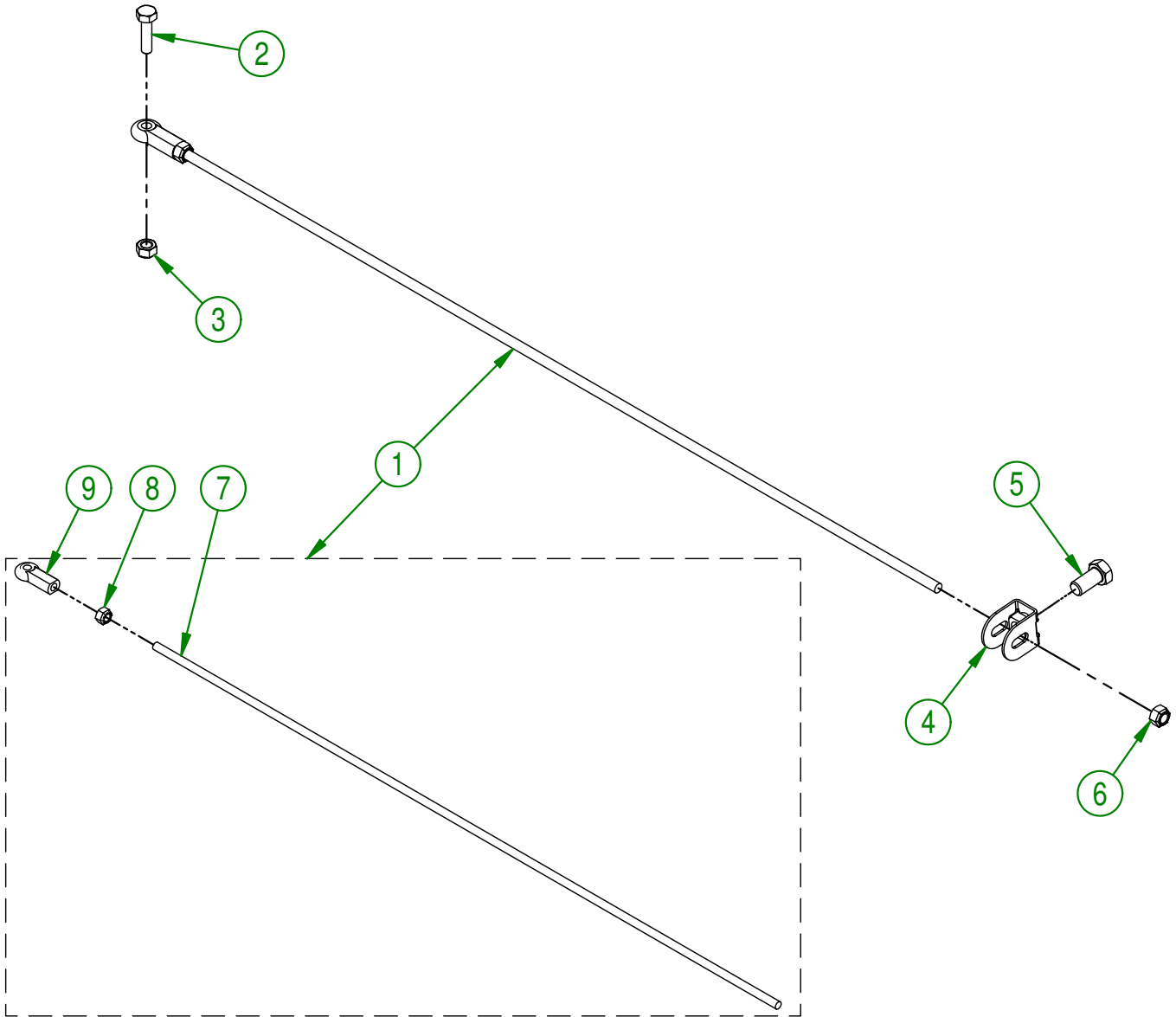

**AGRIMETAL**  
CLUTCH ROD GROUP

CREATION : 04/03/19  
REVISION : 04/03/19

ASSEMBLY : **75-57-0135**

AUTHOR : F.HÉLIE | Page 21 de 35

#	PART #	Qty	TITLE
1	75-31-0100	1	ADJUSTABLE SCREW
2	NC02-07-0018	1	HEX. NUT ZINC 3/8-16
3	NC01-67-0102	1	INTERNALLY THREADED BALL JOINT ROD END 1/4-28
4	75-21-0005	1	HANDLE BLACK KNOB INSERT
5	NC17-46-0018	1	HANDLE KNOB
6	NC01-96-0011	1	NYLON NUT 3/8-16
7	01-01-2485	1	FLAT WASHER 14 GA X 13/16"OD X 25/64" ID
8	NC01-17-0006	1	HEX. BOLT 1/4-20 X 1"
9	NC01-96-0009	1	NYLON-INSERT LOCKNUT ZINC 1/4-20

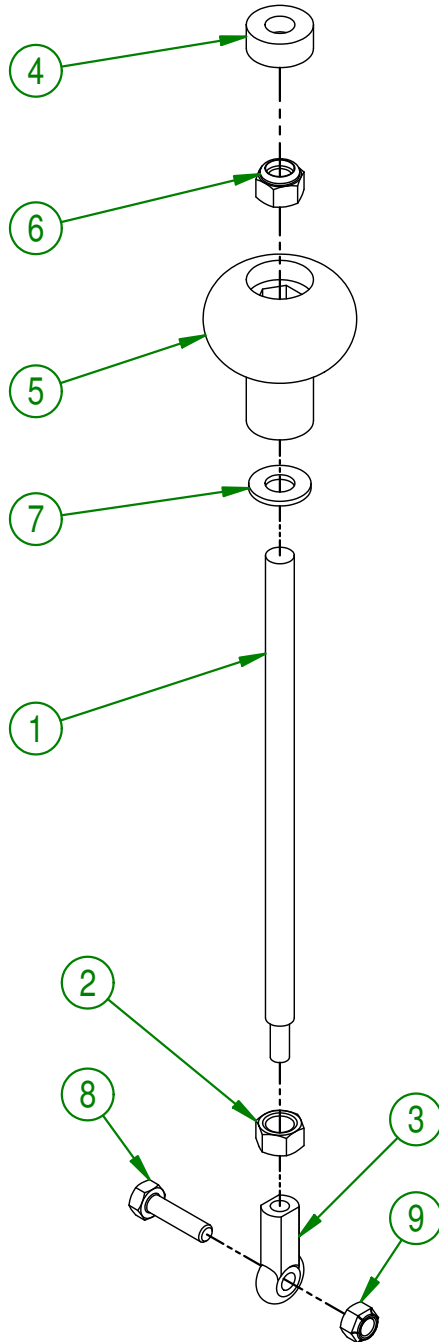
**AGRIMETAL****REAR WHEEL ADJUSTABLE SCREW GROUP**

CREATION : 04/03/19  
 REVISION : 04/03/19

ASSEMBLY : **75-57-0140**

AUTHOR : F.HÉLIE | Page 22 de 35

#	PART #	Qty	TITLE
1	75-46-0525	33	SEED URETHANE TUBE

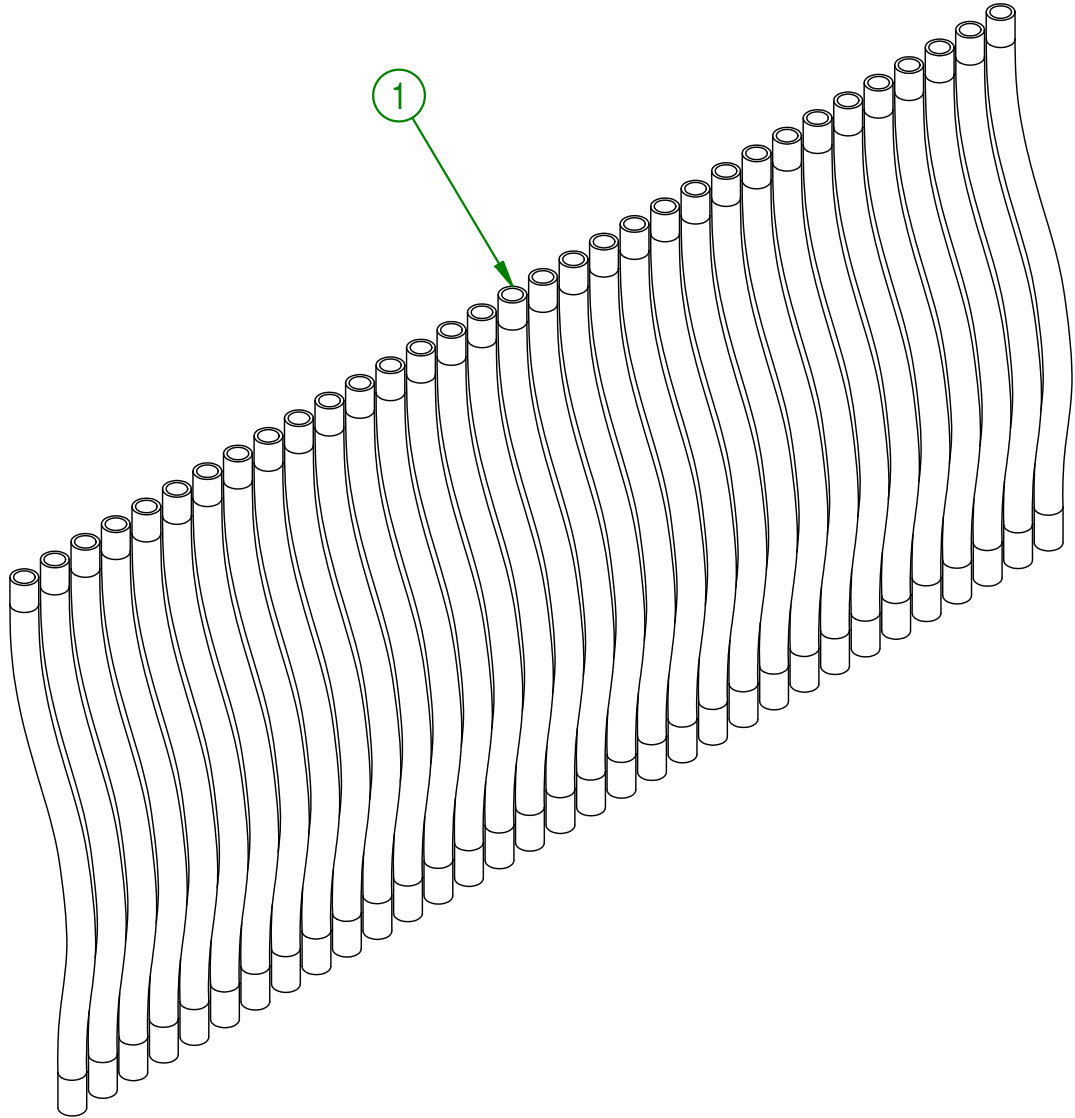

<b>AGRIMETAL</b>	
<b>SEED DISTRIBUTOR TUBE GROUP</b>	
CREATION : 04/03/19	ASSEMBLY : <b>75-57-0145</b>
REVISION : 04/03/19	AUTHOR : F.HÉLIE Page 23 de 35

#	PART #	Qty	TITLE
1	26-03-4800	8	WASHER
2	NC13-15-0059	4	YELLOW RUBBER BASE MOUNT
3	01-33-0010	8	WASHER
4	NC01-17-0119	4	HEX. BOLT GR2 ZINC 3/8-16 X 2 1/4"
5	NC02-32-0012	4	LOCK WASHER ZINC 3/8"
6	NC02-07-0018	4	HEX. NUT ZINC 3/8-16
7	NC14-25-1071	1	V BELT 21/32" (BX-32)
8	NC13-85-0008	1	GALVANISED SPRING

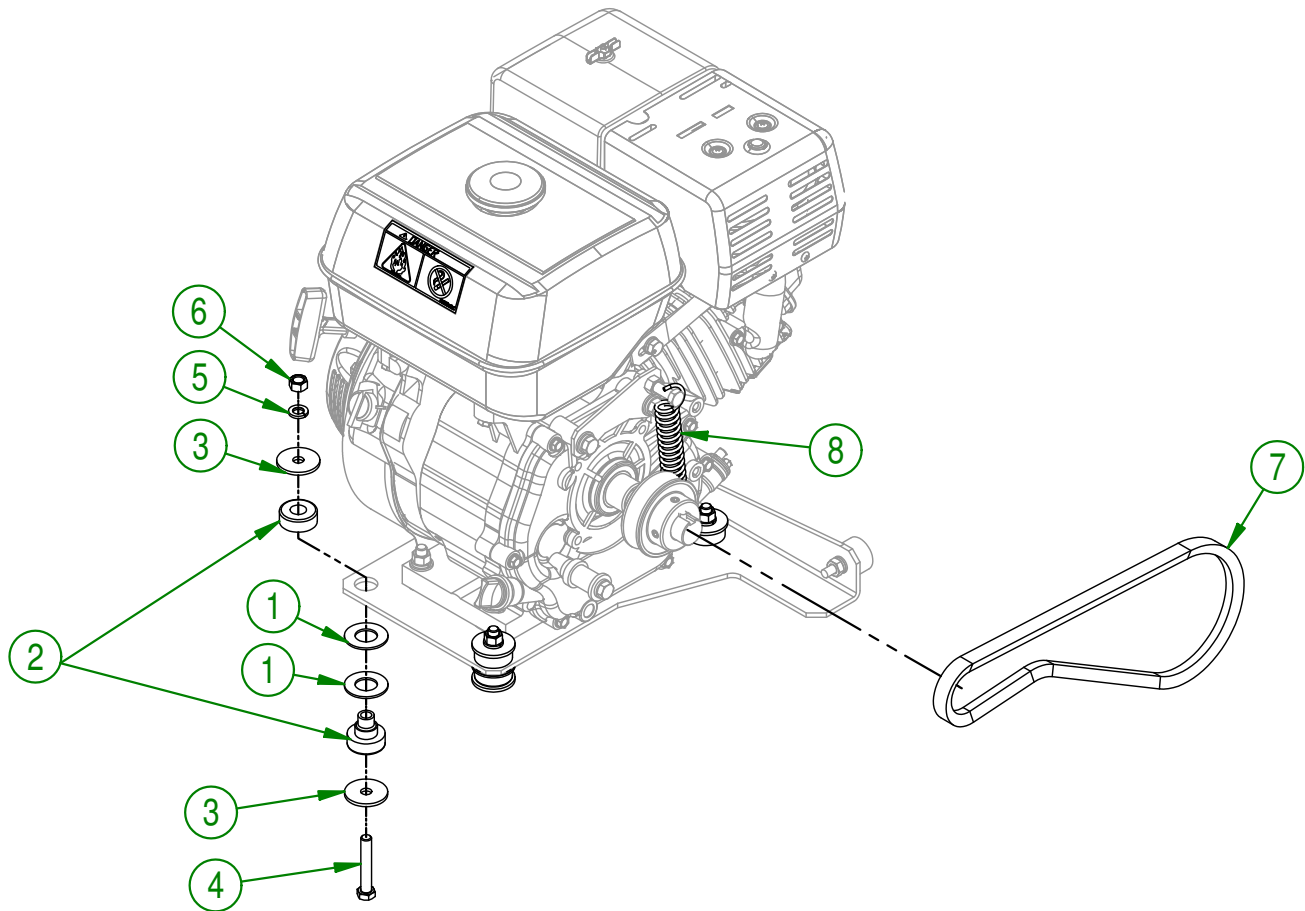
**AGRIMETAL****HONDA 9 H.P.(MANUAL) MOTOR GROUP**

CREATION : 04/03/19  
 REVISION : 04/03/19

ASSEMBLY : **75-57-0150**

AUTHOR : F.HÉLIE | Page 24 de 35

#	PART #	Qty	TITLE
1	01-03-5405	1	MUFFLER SUPPORT
2	NC01-45-0188	1	BOLT MET.GR2 NF ZINC 8MM X 35MM
3	NC02-32-0011	2	LOCK WASHER ZINC 5/16"
4	NC02-22-0008	2	WASHER ZINC 5/16"
5	75-13-1425	1	MOTOR (9 HP) TENSIONER SHAFT
6	75-04-0025	1	MOTOR BASE (9 HP)
7	NC01-17-0117	4	HEX. BOLT GR2 ZINC 3/8-16 X 1 3/4"
8	01-01-2485	4	FLAT WASHER 14 GA X 13/16"OD X 25/64" ID
9	NC02-32-0012	5	LOCK WASHER ZINC 3/8"
10	NC02-07-0018	4	HEX. NUT ZINC 3/8-16
11	21-01-0950	1	FLAT WASHER 10GA 1.005" DIA X 25/64"
12	NC01-65-0087	1	KEY 1/4 X 1/4 X 1 1/2"
13	NC01-17-0119	1	HEX. BOLT GR2 ZINC 3/8-16 X 2 1/4"
14	NC14-62-0212	1	MB30X1/2 PULLEY
15	NC13-15-0034	1	RUBBER ABSORBER
16	NC02-07-0017	1	HEX. NUT 5/16-18
17	NC13-37-0519	1	ARRESTER SPARK

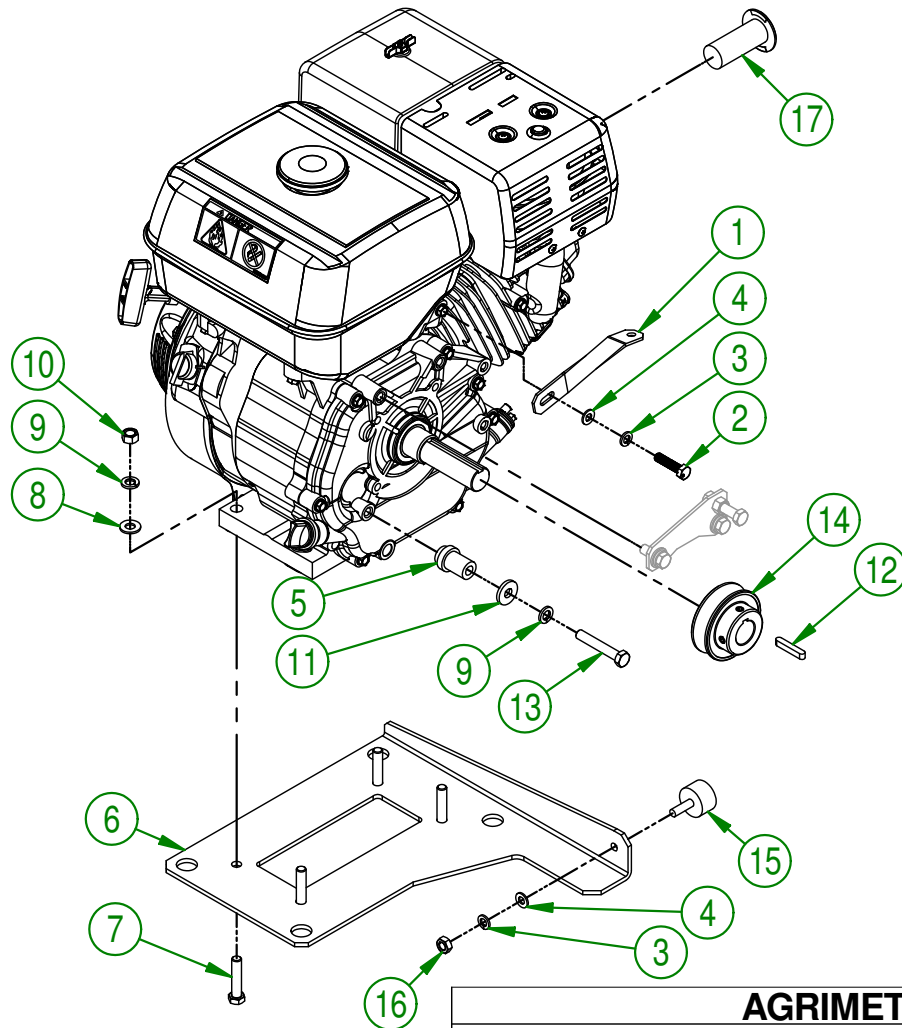
**AGRIMETAL****HONDA (MANUAL) MOTOR 9 H.P. ASSEMBLY**

CREATION : 04/03/19  
 REVISION : 30/08/19

ASSEMBLY : **75-55-0025**

AUTHOR : F.HÉLIE Page 25 de 35

#	PART #	Qty	TITLE
1	75-01-0980	1	TENSIONER SPRING SUPPORT
2	01-01-2485	2	FLAT WASHER 14 GA X 13/16"OD X 25/64" ID
3	NC01-17-0117	1	HEX. BOLT GR2 ZINC 3/8-16 X 1 3/4"
4	NC01-17-0114	2	HEX. BOLT GR2 ZINC 3/8-16 X 1"
5	NC02-32-0012	3	LOCK WASHER ZINC 3/8"
6	NC02-07-0018	2	HEX. NUT ZINC 3/8-16

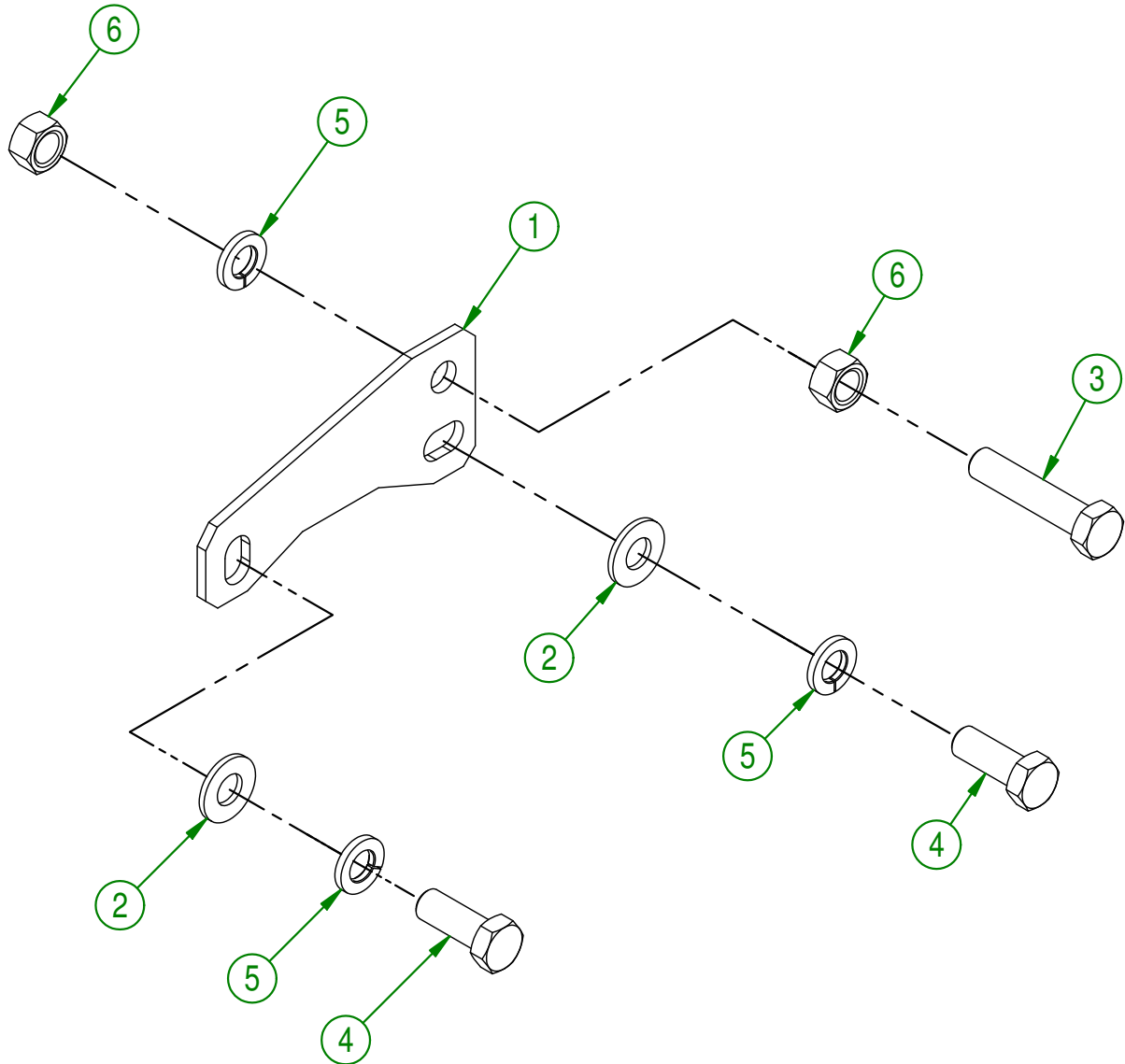
**AGRIMETAL****TENSIONER SPRING SUPPORT GROUP**

CREATION : 04/03/19  
 REVISION : 04/03/19

ASSEMBLY : **75-57-0190**

AUTHOR : F.HÉLIE | Page 26 de 35

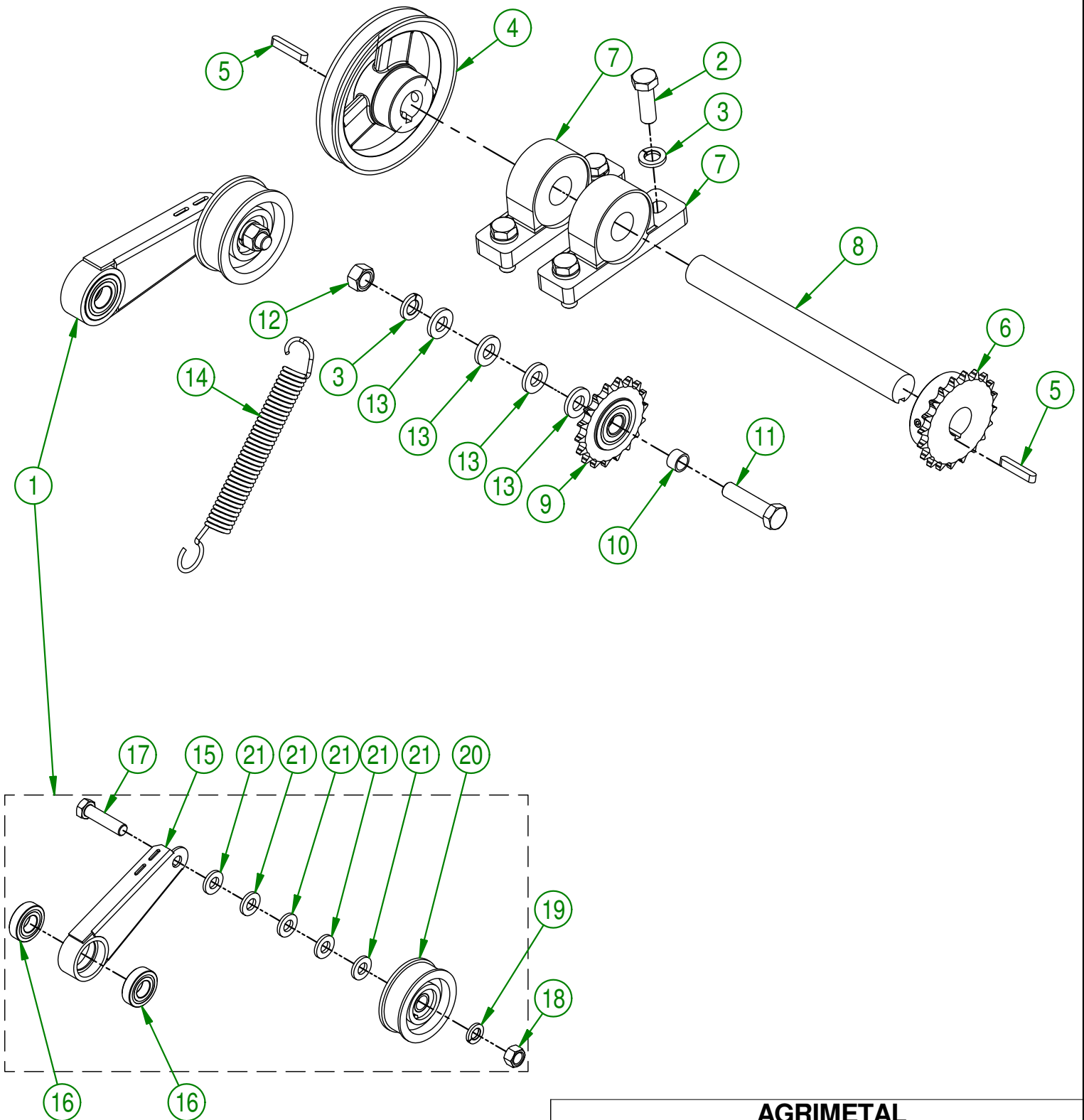

**AGRIMETAL**  
**ROTOR DRIVE GROUP**

CREATION : 04/03/19  
 REVISION : 04/03/19

ASSEMBLY : **75-57-0155**

AUTHOR : F.HÉLIE | Page 27 de 35

## 75-57-0155

#	PART #	Qty	TITLE
1	75-55-0095	1	BELT TENSIONER ARM
2	NC01-17-0249	4	HEX. BOLT GR2 ZINC 1/2-13 X 1 1/2"
3	NC02-32-0014	5	LOCK WASHER ZINC 1/2"
4	NC14-62-0213	1	PULLEY (MB55 X Ø 1" KW 1/4" 2 SS)
5	NC01-65-0087	2	KEY 1/4 X 1/4 X 1 1/2"
6	NC14-55-0254	1	SPROCKET 40B20 X Ø 1" K.W. 1/4" 2SS
7	03-38-0000	2	PILLOW BLOCK UCP205-16 X 1" ID
8	75-13-1410	1	INTERMEDIATE SHAFT
9	NC14-55-0305	1	SPROCKET 40C18H X 6202 X Ø 5/8" SPEC.
10	NC13-80-0061	1	PAD STEEL POWDER 1/2" X 5/8" X 3/8"
11	NC01-17-0251	1	HEX. BOLT GR2 ZINC 1/2-13 X 2"
12	NC02-07-0020	1	HEX. NUT ZINC 1/2-13
13	01-01-0925	4	WASHER
14	NC13-85-0008	1	GALVANISED SPRING

## 75-55-0095

#	PART #	Qty	TITLE
15	75-50-0065	1	BELT TENSIONER
16	NC14-75-0110	2	BALL BEARING R12 2RS
17	NC01-17-0251	1	HEX. BOLT GR2 ZINC 1/2-13 X 2"
18	NC02-07-0020	1	HEX. NUT ZINC 1/2-13
19	NC02-32-0014	1	LOCK WASHER ZINC 1/2"
20	01-39-0600	1	IDLER PULLEY PI-300 ASSY
21	01-01-0925	5	WASHER

**AGRIMETAL**  
**ROTOR DRIVE GROUP**

CREATION : 04/03/19  
 REVISION : 04/03/19

ASSEMBLY : **75-57-0155**

AUTHOR : F.HÉLIE Page 28 de 35

#	PART #	Qty	TITLE
1	75-57-0170	1	BELT GUARD GROUP (STICKER INCLUDED)
2	NC01-64-0005	2	OVAL SLEEVE (ALUMINUM)
3	NC01-17-0004	3	HEX. BOLT GR2 ZINC 1/4-20 X 3/4"
4	NC02-32-0010	3	LOCK WASHER ZINC 1/4"
5	NC02-25-0007	3	WASHER ZINC 0.281 = 9/32
6	75-41-0135	1	BELT GUARD WIRE Ø1/16 X 18" LG.

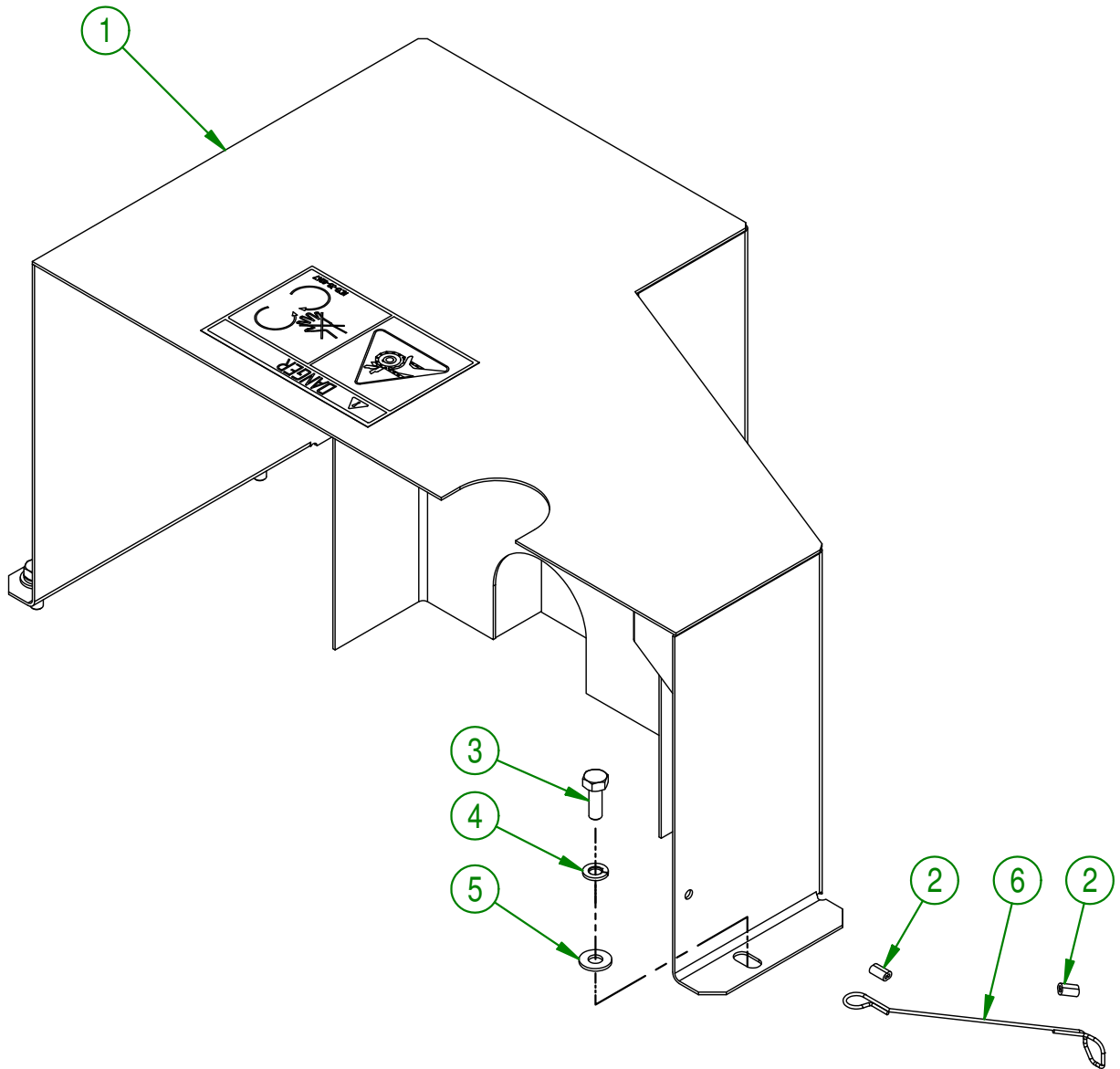

<b>AGRIMETAL</b>	
<b>BELT GUARD GROUP</b>	
CREATION : 04/03/19	ASSEMBLY : <b>75-57-0165</b>
REVISION : 04/03/19	AUTHOR : F.HÉLIE   Page 29 de 35

#	PART #	Qty	TITLE
1	NC14-75-0009	4	PRESSED STEEL FLANGED HOUSING F5 O.D. 3 3/4"
2	NC14-75-0016	2	SEAL BALL BEARING SB 205-16
3	NC01-04-0056	6	CARR. BOLT 5/16-18 X3/4"
4	NC02-14-0006	6	HEX. NUT SPECIAL FLANGET NC 5/16-18 B GRADE
5	75-04-0035	2	ROTOR BEARING PLATE
6	NC01-17-0112	8	HEX. BOLT GR2 ZINC 3/8-16 X 3/4"
7	NC02-32-0012	8	LOCK WASHER ZINC 3/8"
8	33-41-0900	1	SQUARE KEY
9	NC14-55-0250	1	SPROCKET 40B28H X 1" (K.W. 1/4" 2SS)
10	75-37-1010	1	CHAIN #40 X 30" + 1 LINK

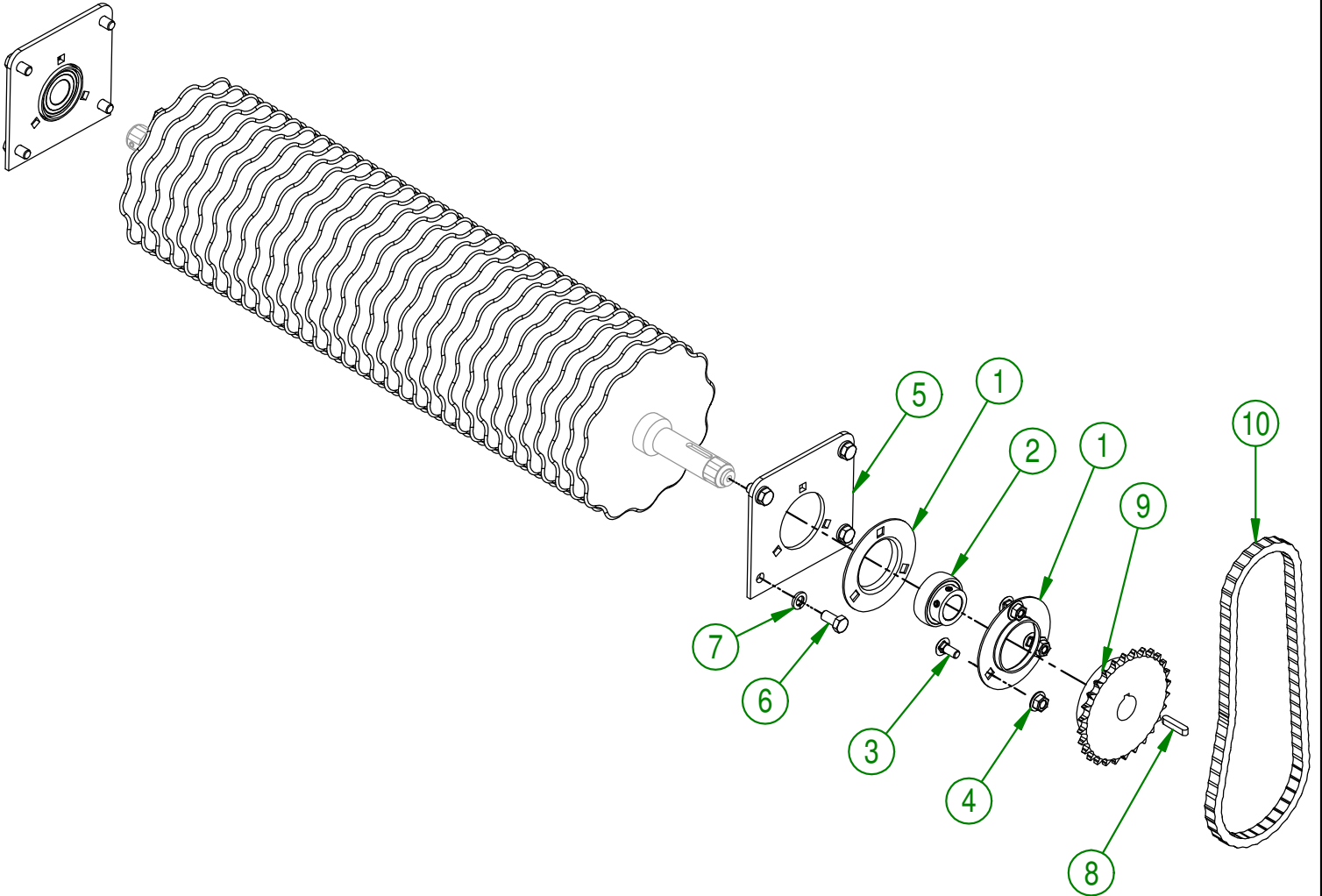

**AGRIMETAL**  
**ROTOR GROUP**

CREATION : 13/04/20  
 REVISION : 13/04/20

ASSEMBLY : **75-57-0176**

AUTHOR : F.HÉLIE Page 30 de 35

75-55-0087

#	PART #	Qty	TITLE
1	75-55-0081	1	ROTOR SHAFT
2	75-21-0057	32	BLADE BUSHING 0.110" X 3/4" C/C
3	47-41-0900	1	SQUARE KEY
4	75-13-2000	1	ROTOR DRIVE TIP
5	75-32-9950	1	ROTOR NYLON INSERT LOCKNUT
6	75-20-0935	33	

75-55-0081

#	PART #	Qty	TITLE
7	75-25-2400	1	ROTOR SHAFT
8	47-41-0900	1	SQUARE KEY
9	75-13-2005	1	ROTOR LOCK TIP
10	75-32-9950	1	ROTOR NYLON INSERT LOCKNUT
11	NC01-69-0419	1	SPRING TIGHTENER PIN ZINC 3/16 XI"

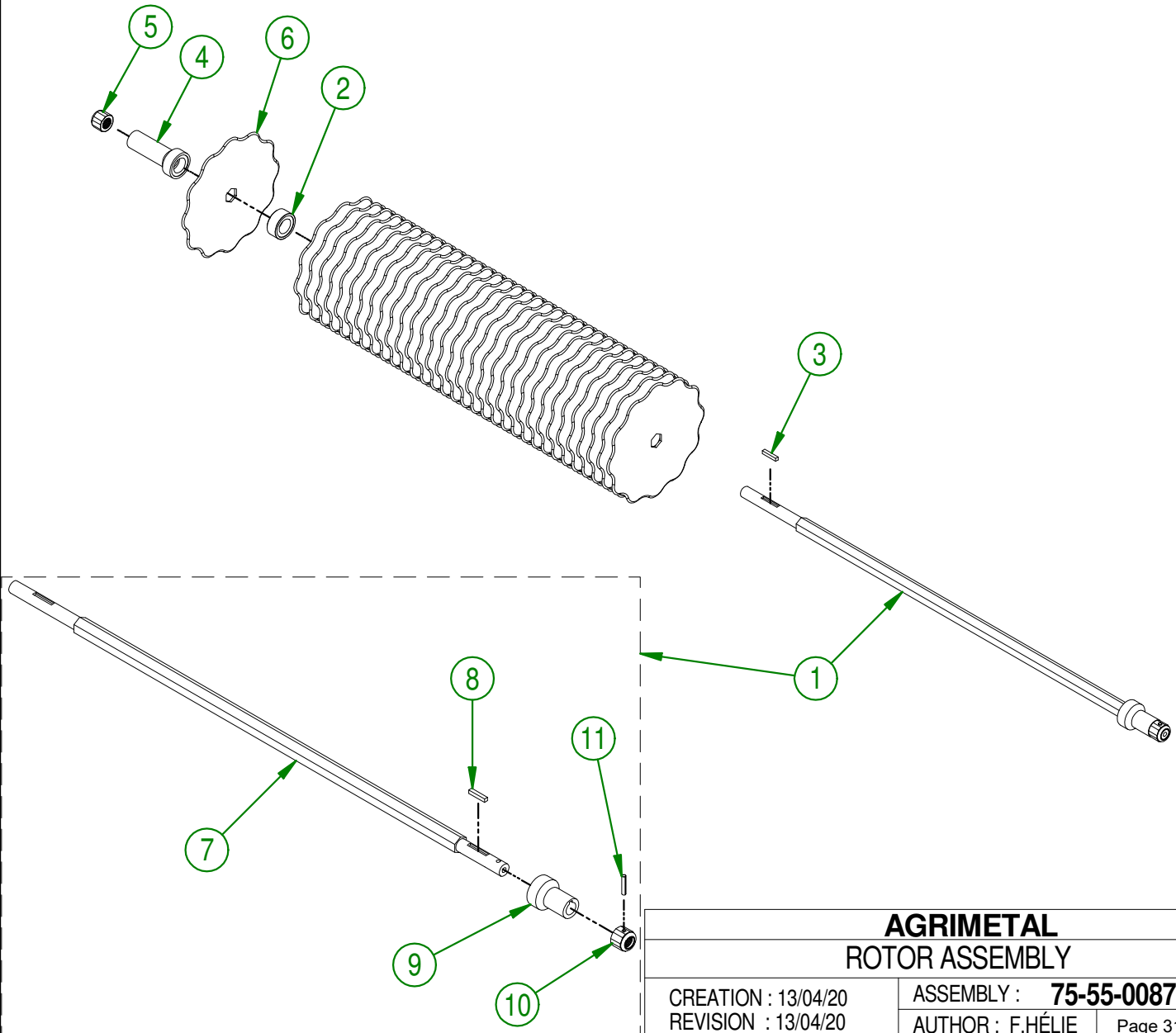

**AGRIMETAL**  
**ROTOR ASSEMBLY**

CREATION : 13/04/20  
 REVISION : 13/04/20

ASSEMBLY : **75-55-0087**

AUTHOR : F.HÉLIE Page 31 de 35

#	PART #	Qty	TITLE
1	NC13-30-0237	1	PLASTIC TUBE FOR OPERATOR'S MANUAL
2	NC01-04-0003	3	CARR. BOLT GR2 ZINC 1/4-20 X 3/4"
3	NC02-25-0007	3	WASHER ZINC 0.281 = 9/32
4	NC01-96-0009	3	NYLON-INSERT LOCKNUT ZINC 1/4-20
5	75-98-0520	1	OPÉR.MAN.OVERSEEDER (ENGLISH)
6	01-55-0030	1	DRAIN OIL SLAB "STICKER INCLUDED"

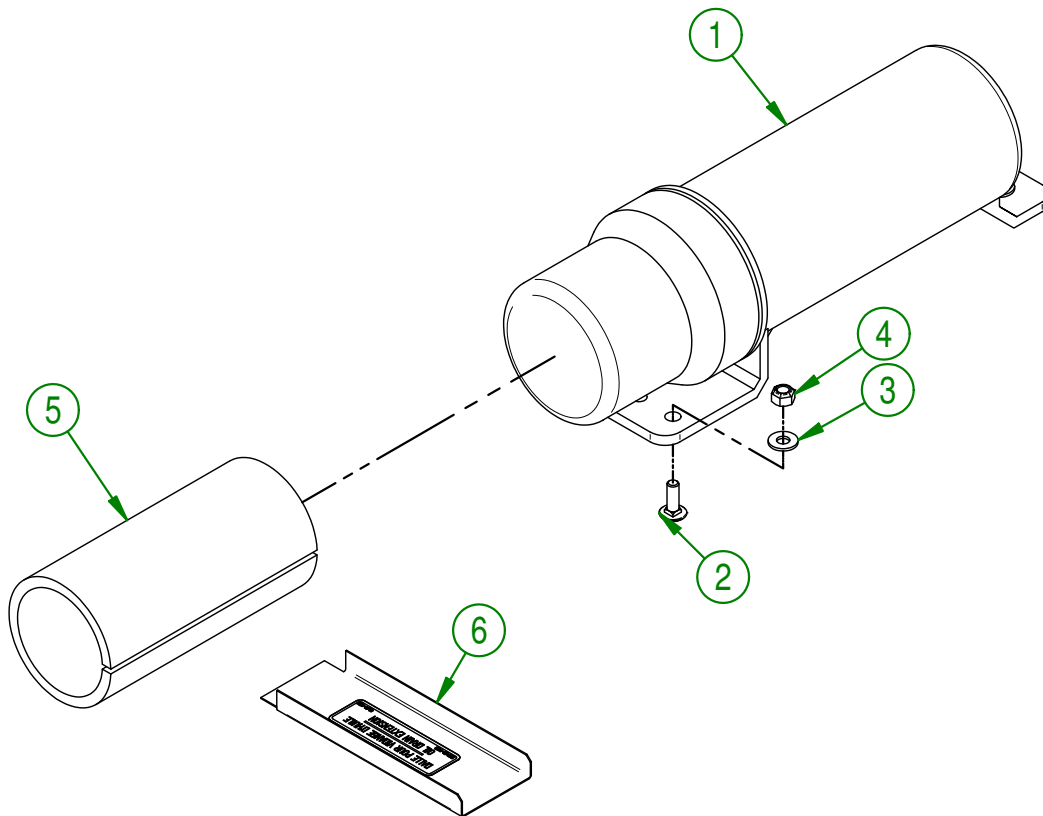
**AGRIMETAL****OPERATOR'S MANUAL GROUP**

CREATION : 16/01/19  
 REVISION : 04/03/19

ASSEMBLY : **75-57-0178**

AUTHOR : F.HÉLIE | Page 32 de 35

#	PART #	Qty	TITLE
1	75-50-0035	1	TRAILER FRAME
2	75-01-7565	1	LEFT TRAILER RAMP
3	75-01-7566	1	RIGHT TRAILER RAMP
4	75-01-0950	2	TRAILER RAMP BRACKET
5	NC14-70-0297	2	WHEEL 10" ASSEMBLY WITH BEARING $\varnothing$ 3/4"
6	NC01-63-0036	2	DRAW LATCH 6 1/2"
7	NC01-04-0056	6	CARR. BOLT 5/16-18 X3/4"
8	NC02-22-0008	6	WASHER ZINC 5/16"
9	NC01-96-0010	6	NYLON NUT HEX. ZINC 5/16-18
10	NC02-40-0080	6	MACHINE SCREWS SQUARE SOCKET #10-24 X 1/2" LG
11	NC01-96-0006	6	NYLON NUT ZINC 10-24
12	NC01-17-0114	2	HEX. BOLT GR2 ZINC 3/8-16 X 1"
13	NC02-32-0012	2	LOCK WASHER ZINC 3/8"
14	01-33-0010	2	WASHER
15	NC01-63-0015	2	COTTER PIN Z 1/8" X 2 5/8"

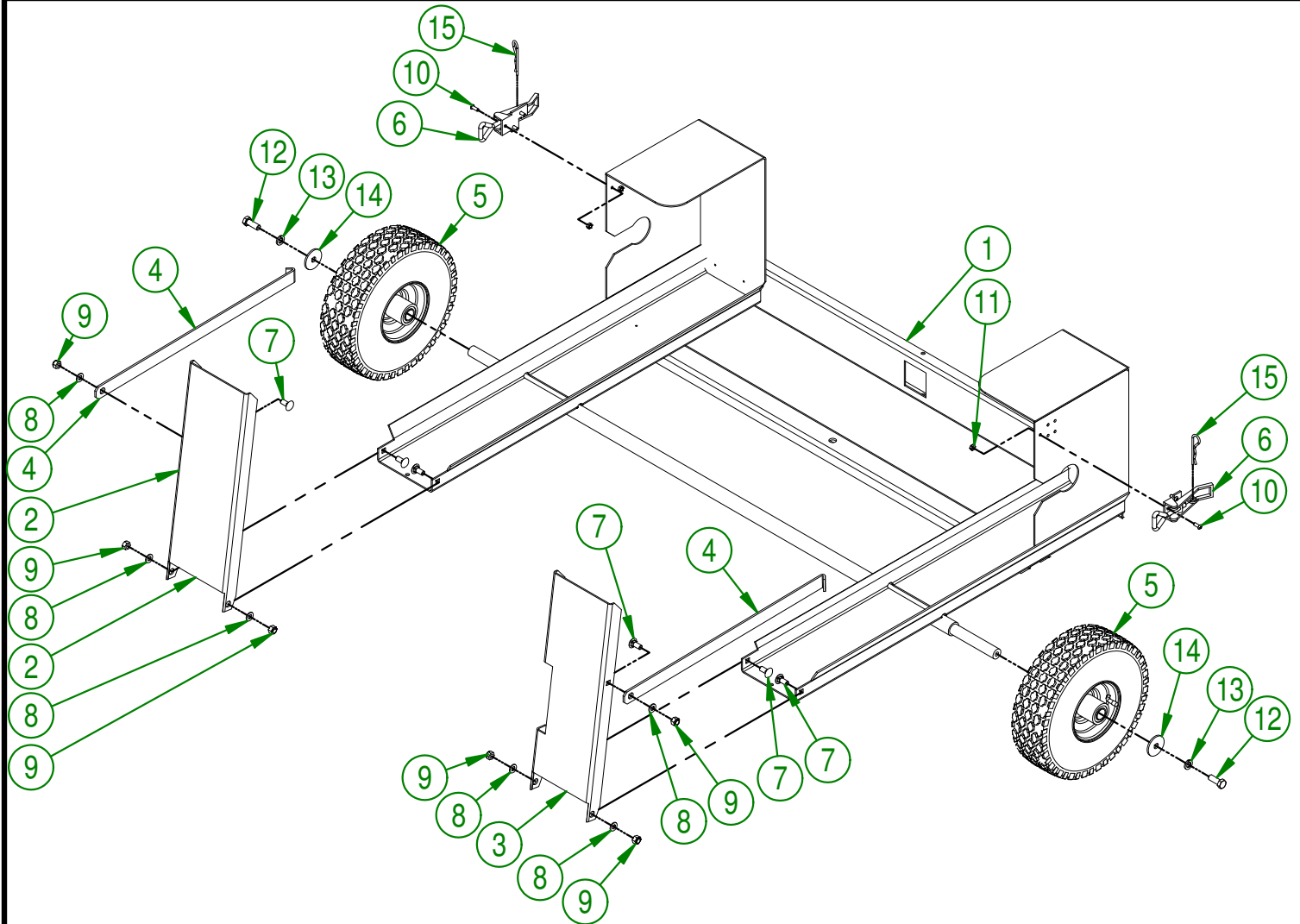

**AGRIMETAL**  
TRAILER ASSEMBLY

CREATION : 04/03/19  
REVISION : 04/03/19

ASSEMBLY : **75-55-0005**

AUTHOR : F.HÉLIE Page 33 de 35

#	PART#	QTY	TITLE
1	75-50-0040	1	HITCH
2	NC01-17-0123	2	HEX. BOLT GR2 ZINC 3/8-16 X 3 1/4"
3	NC02-32-0012	2	LOCK WASHER ZINC 3/8"
4	NC02-07-0018	2	HEX. NUT ZINC 3/8-16
5	NC01-75-0015	1	RAPID LINK DIA. 5/16"-8MM, 1300-1760 LBS WLL
6	NC01-17-0116	1	HEX. BOLT GR2 ZINC 3/8-16 X 1 1/2"
7	NC01-96-0011	1	NYLON NUT 3/8-16
8	NC02-22-1010	4	3/8" ZINC PLATED WASHER
9	NC01-17-0255	1	HEX. BOLT GR2 ZINC 1/2-13 X 3"
10	NC01-96-0014	1	NYLON-INSERT LOCKNUT ZINC 1/2-13
11	NC02-25-0011	3	WASHER SAE ZINC 17/32 ID
12	26-41-0000	1	SAFETY CHAIN 4.8MM X 2/0 X 58" LONG
13	23-50-0045	1	HITCH HAND
14	NC13-80-0290	1	2" HITCH BALL COUPLER
15	NC01-93-0014	2	LOCK NUT ZINC 1/2-13
16	NC01-25-0257	2	HEX. BOLT GR5 ZINC 1/2-13 X 3 1/2"
17	23-09-0100	1	HITCH SPACER
18	NC02-22-0012	2	WASHER ZINC 1/2 BOLT = 9/16"Ø X 1 3/8" OD

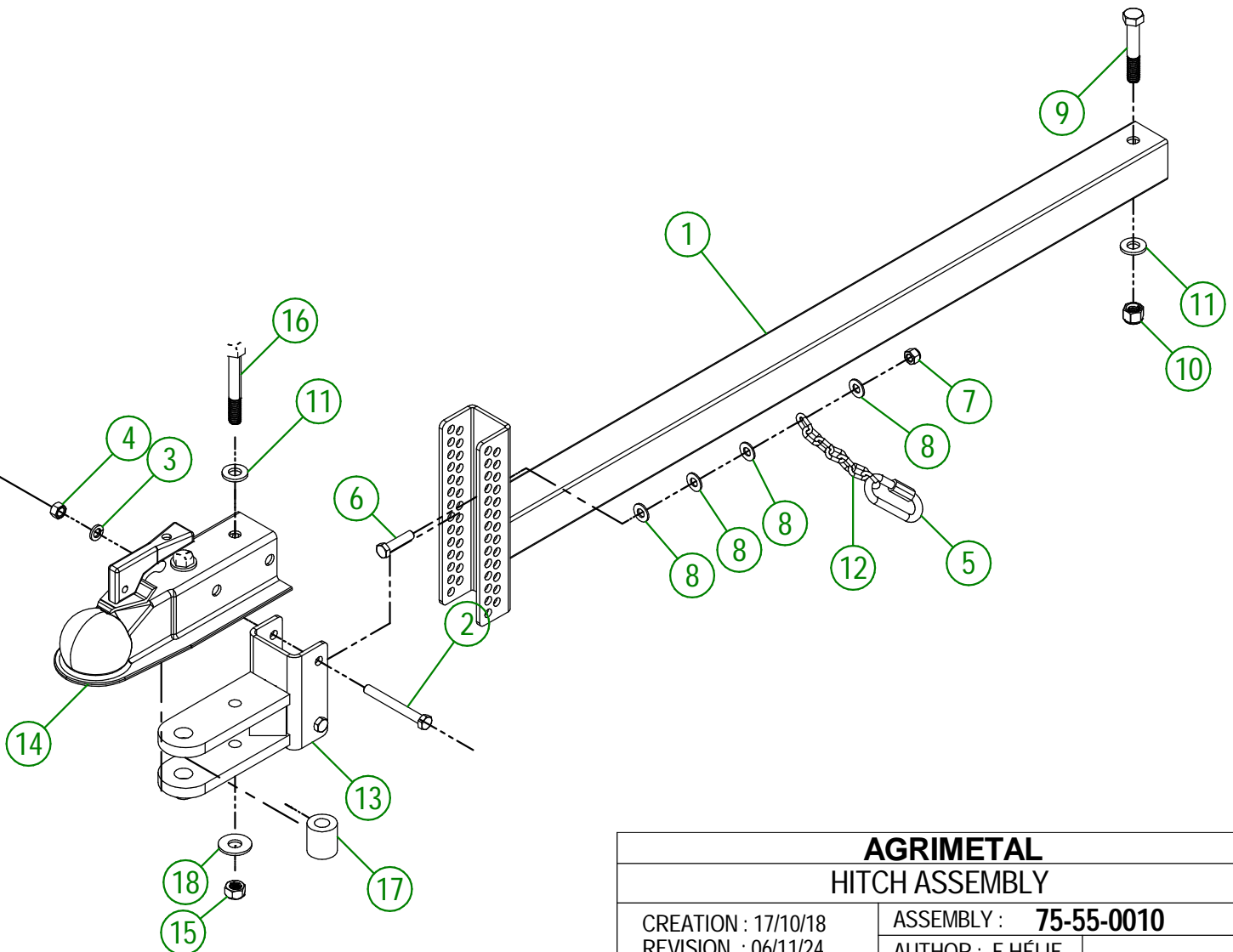

<b>AGRIMETAL</b>	
<b>HITCH ASSEMBLY</b>	
CREATION : 17/10/18	ASSEMBLY : <b>75-55-0010</b>
REVISION : 06/11/24	AUTHOR : F.HÉLIE

#	PART #	QTY	TITLE
1	NCI3-33-0189	1	STICKER DANGER (PERSON AND CHAIN DRIVE)
2	NCI3-33-0247	1	STICKER DANGER
3	NCI3-33-0002	2	STICKER AGRIMETAL
4	NCI3-33-0183	1	STICKER CAUTION OPERATION MANUAL
5	NCI3-33-0197	1	STICKER SEEDING RATE BY SPROCKETS
6	NCI3-33-0252	1	STICKER (FIRE RISK)
7	NCI3-33-0035	1	STICKER AGRIMETAL
8	NCI3-33-0219	1	STICKER WARNING
9	NCI3-33-0023	1	STICKER OIL DRAIN EXTENSION

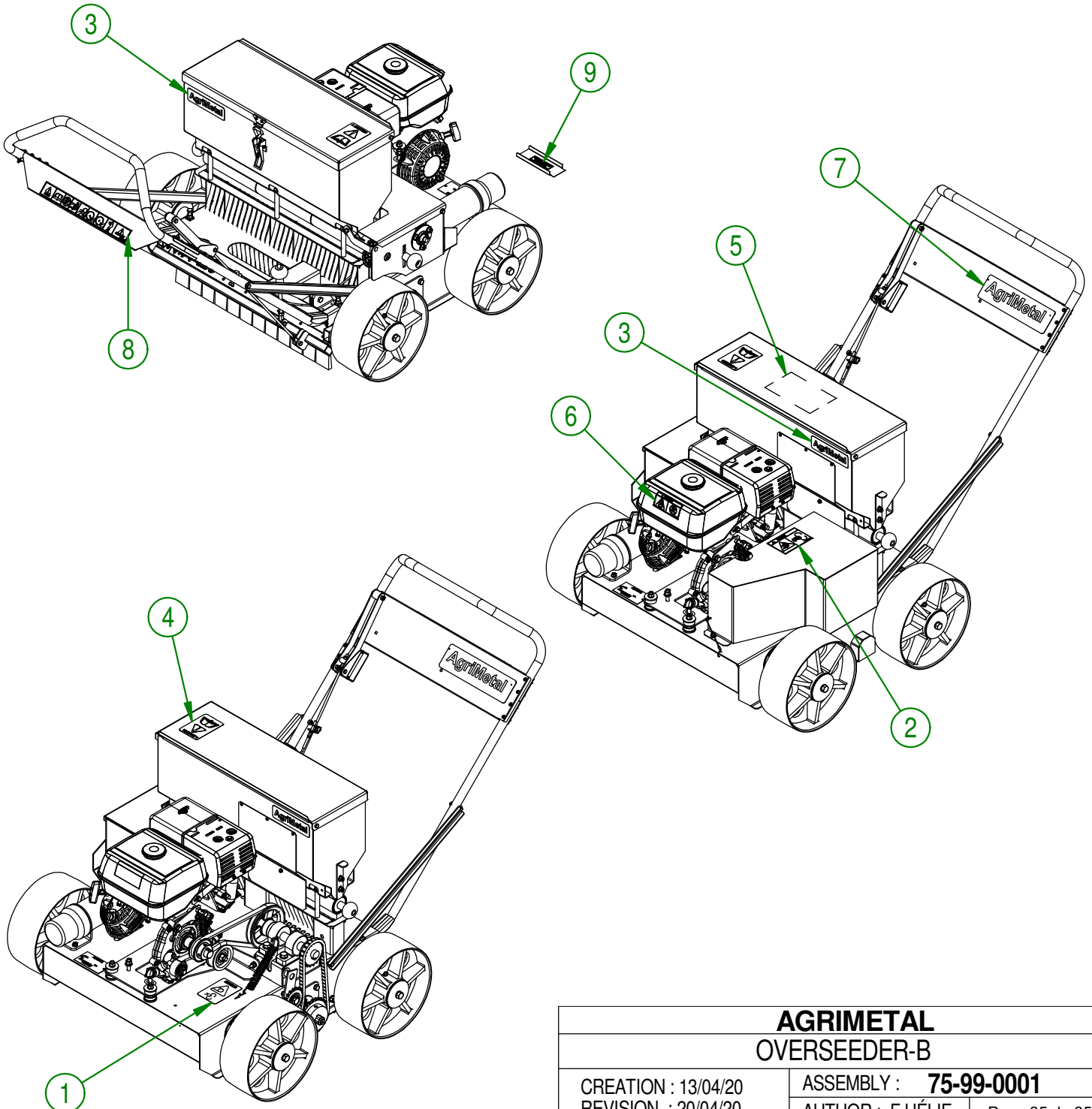

**AGRIMETAL**  
**OVERSEEDER-B**

CREATION : 13/04/20  
REVISION : 20/04/20

ASSEMBLY : **75-99-0001**

AUTHOR : F.HÉLIE Page 35 de 35