

# AgriMetal

## PARTS LIST

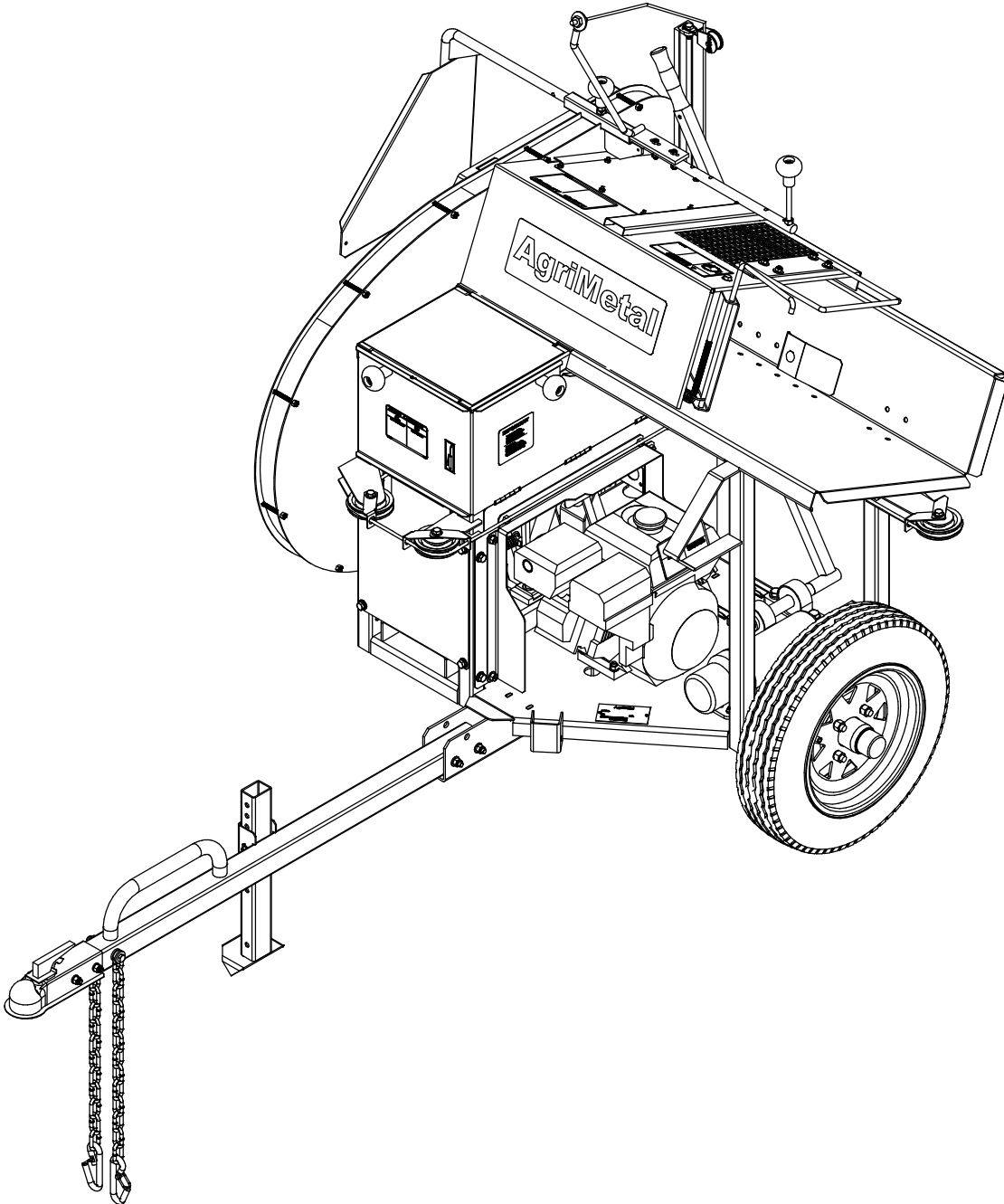

**BENCH SAW (MOD:MBS 724)**

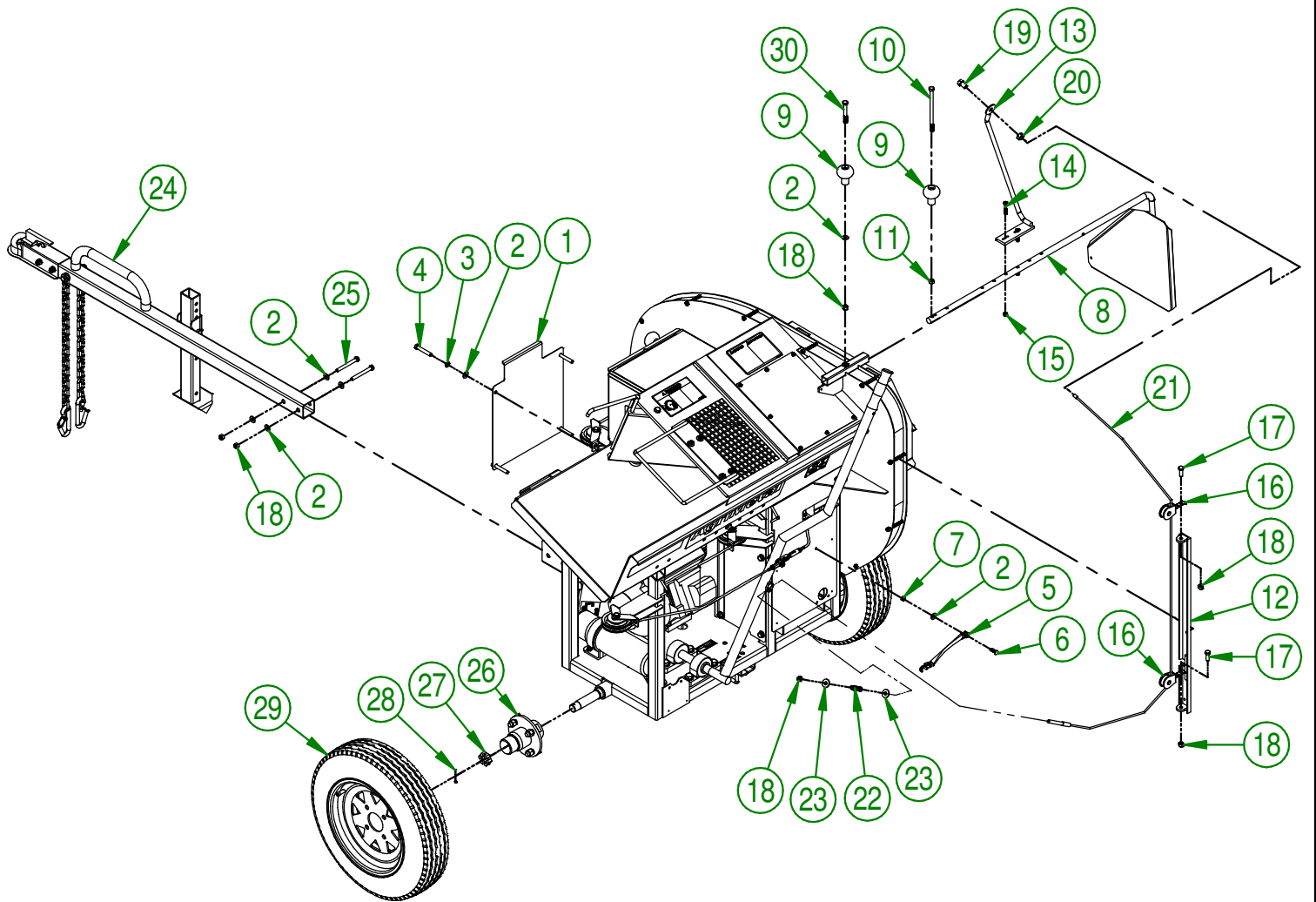

<b>AGRIMETAL</b>	
<b>BANC DE SCIE (MOD:724)</b>	
CREATION : 20/11/18	ASSEMBLY : <b>55-99-2000</b>
REVISION : 26/11/18	AUTHOR : J.KABWE

## 55-99-2000

#	PART #	Qty	TITLE
1	55-01-3165	1	BELT GUARD (FRONT BOTTOM)
2	01-01-2485	10	FLAT WASHER 14 GA X 13/16"OD X 25/64" ID
3	NC02-32-0012	4	LOCK WASHER ZINC 3/8"
4	NC01-17-0119	4	HEX. BOLT GR2 ZINC 3/8-16 X 2 1/4"
5	NC13-15-0008	1	RUBBER STRAP
6	NC01-05-0005	1	CARR. BOLT GR5 FLZ 1/4-20 X 1"
7	NC01-96-0009	1	NYLON-INSERT LOCKNUT ZINC 1/4-20
8	55-50-5015	1	CUTTING GUIDE
9	NC17-46-0018	2	HANDLE KNOB
10	NC01-17-0134	1	HEX. BOLT GR2 NC ZINC 3/8-16 X 6
11	NC02-07-0018	1	HEX. NUT ZINC 3/8-16
12	55-50-5065	1	PULLEY SUPPORT
13	55-50-5060	1	CUTTING GUIDE HANDLE
14	NC01-37-0008	2	HEX. BOLT GR8 1/4-28 X 1 1/2"
15	NC01-97-0004	2	NYLON-INSERT LOCKNUT ZINC 1/4-28
16	55-50-5055	2	SIMPLE HANGING PULLEY 1 1/2"
17	NC01-17-0114	2	HEX. BOLT GR2 ZINC 3/8-16 X 1"
18	NC01-96-0011	6	NYLON NUT 3/8-16
19	55-30-9950	1	CUTTING GUIDE CABLE BOLT
20	NC01-96-0014	1	NYLON-INSERT LOCKNUT ZINC 1/2-13
21	NC17-02-0303	1	CABLE KIT 62"
22	NC13-85-0027	1	COMPRESSION SPRING .500" DIA. X 1 3/4" LG.
23	21-01-0950	2	FLAT WASHER 10GA 1.005" DIA X 25/64"
24	55-55-5005	1	HITCH ASSY.
25	NC01-17-0123	2	HEX. BOLT GR2 ZINC 3/8-16
26	NC14-70-0305	2	WHEEL HUB CAGE 4 Ø 4"CCB 5 1/2" OUT. 2000/LBS ENS. 1 1/16" BEARING
27	NC14-70-0310	2	SLOTTED NUT 1-14
28	NC14-70-0311	2	COTTER PIN ZINC 5/32" X 2"
29	NC14-70-0313	2	WHEEL 20" DIA. X 5" LARG X 12" RIM
30	NC01-17-0121	1	HEX. BOLT GR2 ZINC 3/8-16 X 2 1/2"

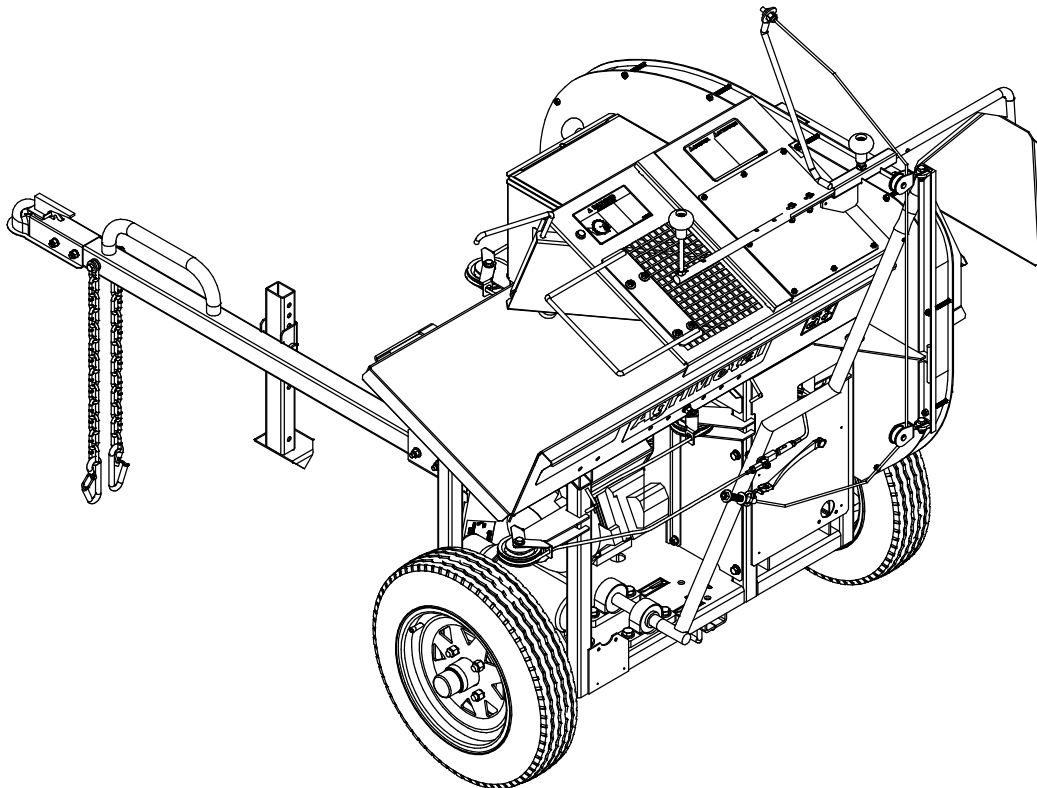

#	PART #	Qty	TITLE
1	55-57-5000	1	FRAME GROUP " STICKER INCLUDED"
2	NC13-15-0034	2	RUBBER ABSORBER
3	NC02-32-0011	2	LOCK WASHER ZINC 5/16"
4	NC02-07-0017	2	HEX. NUT 5/16-18
5	NC13-30-0237	1	PLASTIC TUBE FOR OPERATOR'S MANUAL
6	NC01-04-0003	3	CARR. BOLT GR2 ZINC 1/4-20 X 3/4"
7	NC02-25-0007	3	WASHER ZINC 0.281 = 9/32
8	NC01-96-0009	7	NYLON-INSERT LOCKNUT ZINC 1/4-20
9	55-98-0540	1	OPER. MAN. PORTABLE BENCH SAW
10	55-42-0005	1	HUBLLOT
11	NC02-40-0080	8	MACHINE SCREWS SQUARE SOCKET #10-24 X 1/2" LG
12	NC01-96-0006	8	NYLON NUT ZINC 10-24
13	55-50-5040	1	TABLE GUAR ROD
14	NC01-04-0002	4	CARR. BOLT GR2 ZINC 1/4-20 X 5/8"
15	36-01-2430	4	WASHER
16	55-01-2480	1	STOPPER
17	NC01-04-0110	1	CARR. BOLT GR2 ZINC 3/8-16 X 1 1/4"
18	01-01-2485	1	FLAT WASHER 14 GA X 13/16"OD X 25/64" ID
19	NC02-32-0012	1	LOCK WASHER ZINC 3/8"
20	NC02-07-0018	1	HEX. NUT ZINC 3/8-16

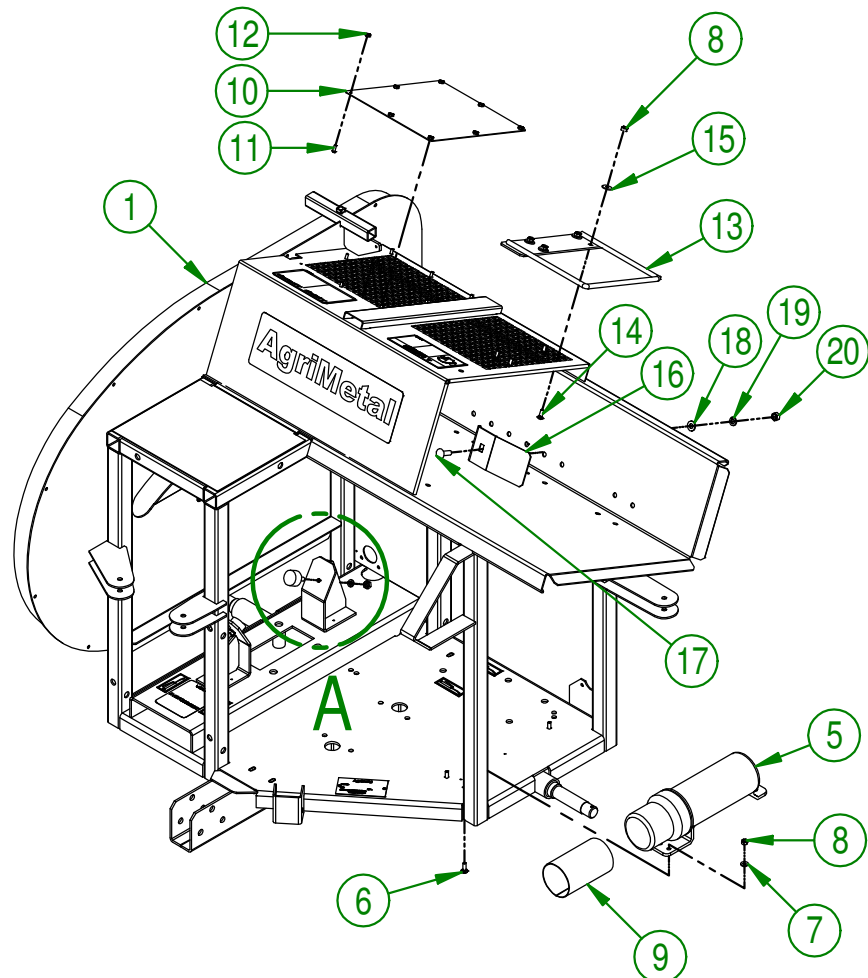

**DETAIL A**

**AGRIMETAL**  
**COMPLET FRAME GROUP**

CREATION : 20/11/18  
 REVISION : 26/11/18

ASSEMBLY : **55-57-6525**

AUTHOR : J.KABWE

Page 3 de 17

#	PART #	Qty	TITLE
1	55-55-5030	1	BLADE PIVOT ASSY.
2	NC02-32-0016	4	LOCK WASHER ZINC 5/8"
3	NC01-17-0404	4	HEX. BOLT GR2 ZINC 5/8-11 X 3 1/2"
4	NC02-07-0022	4	HEX. NUT ZINC 5/8-11
5	01-41-0910	1	KEY WAY
6	NC14-62-0207	1	IRON PULLEY MB45 X 1"Ø KW 1/4 2SS
7	NC14-25-0908	1	V BELT SUPER HI-POWER 5/8 B-43 6946 OR MXV5-460
8	01-01-0925	7	WASHER
9	NC17-46-0004	1	IDLER PULLEY PI-300
10	NC01-17-0257	1	HEX. BOLT GR2 ZINC 1/2-13 X 3 1/2"
11	NC02-32-0014	1	LOCK WASHER ZINC 1/2"
12	NC02-07-0020	1	HEX. NUT ZINC 1/2-13
13	NC13-85-0008	1	GALVANISED SPRING
14	NC01-96-0014	1	NYLON-INSERT LOCKNUT ZINC 1/2-13

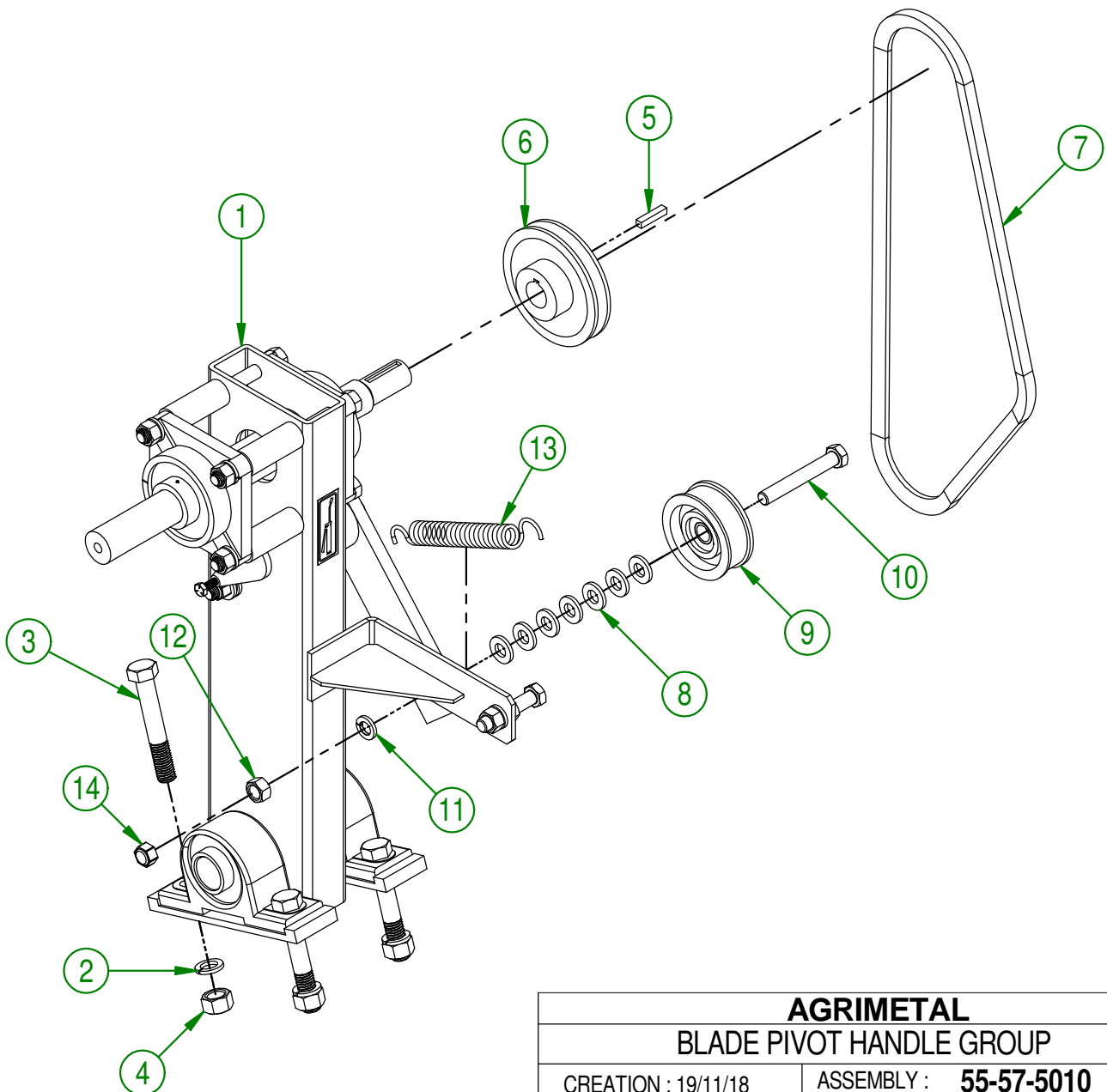

<b>AGRIMETAL</b>	
<b>BLADE PIVOT HANDLE GROUP</b>	
CREATION : 19/11/18	ASSEMBLY : <b>55-57-5010</b>
REVISION : 26/11/18	AUTHOR : J.KABWE   Page 4 de 17

#	PART #	Qty	TITLE
1	55-57-5011	1	BLADE HANDLE PIVOT GROUP "STICKER INCLUDED"
2	55-38-0005	2	HANDLE BLADE BEARING (UCF207-20)
3	55-13-0810	8	BEARING BUSHING (UCF-207)
4	55-21-0020	4	BLADE BALL BEARING SPACER
5	NC01-17-0269	4	HEX. BOLT GR2 ZINC 1/2-13 X 6 1/2"
6	NC02-32-0014	6	LOCK WASHER ZINC 1/2"
7	NC02-07-0020	6	HEX. NUT ZINC 1/2-13
8	55-20-0050	1	BLADE SHAFT
9	55-21-0025	1	CABLE SUPPORT (BLADE HANDLE)
10	NC02-32-0010	1	LOCK WASHER ZINC 1/4"
11	NC01-29-0008	1	HEX. BOLT GR5 NF ZINC 1/4-28 X 1 1/2"
12	NC02-32-0012	1	LOCK WASHER ZINC 3/8"
13	NC01-17-0121	1	HEX. BOLT GR2 ZINC 3/8-16 X 2 1/2"
14	55-21-0015	1	TIGHTENER HANDLE SPACER
15	55-05-2500	1	BEL TIGHTENER HANDLE
16	NC01-17-0271	1	HEX BOLT GR2 NC ZINC 1/2-13 X 7"
17	NC02-25-0011	3	WASHER SAE ZINC 17/32 ID
18	NC01-96-0014	1	NYLON-INSERT LOCKNUT ZINC 1/2-13
19	NC01-17-0253	1	HEX. BOLT GR2 ZINC 1/2-13 X 2 1/2"
20	55-38-0000	2	BLADE HANDLE BEARING
21	55-21-0200	2	BEARING GUIDE

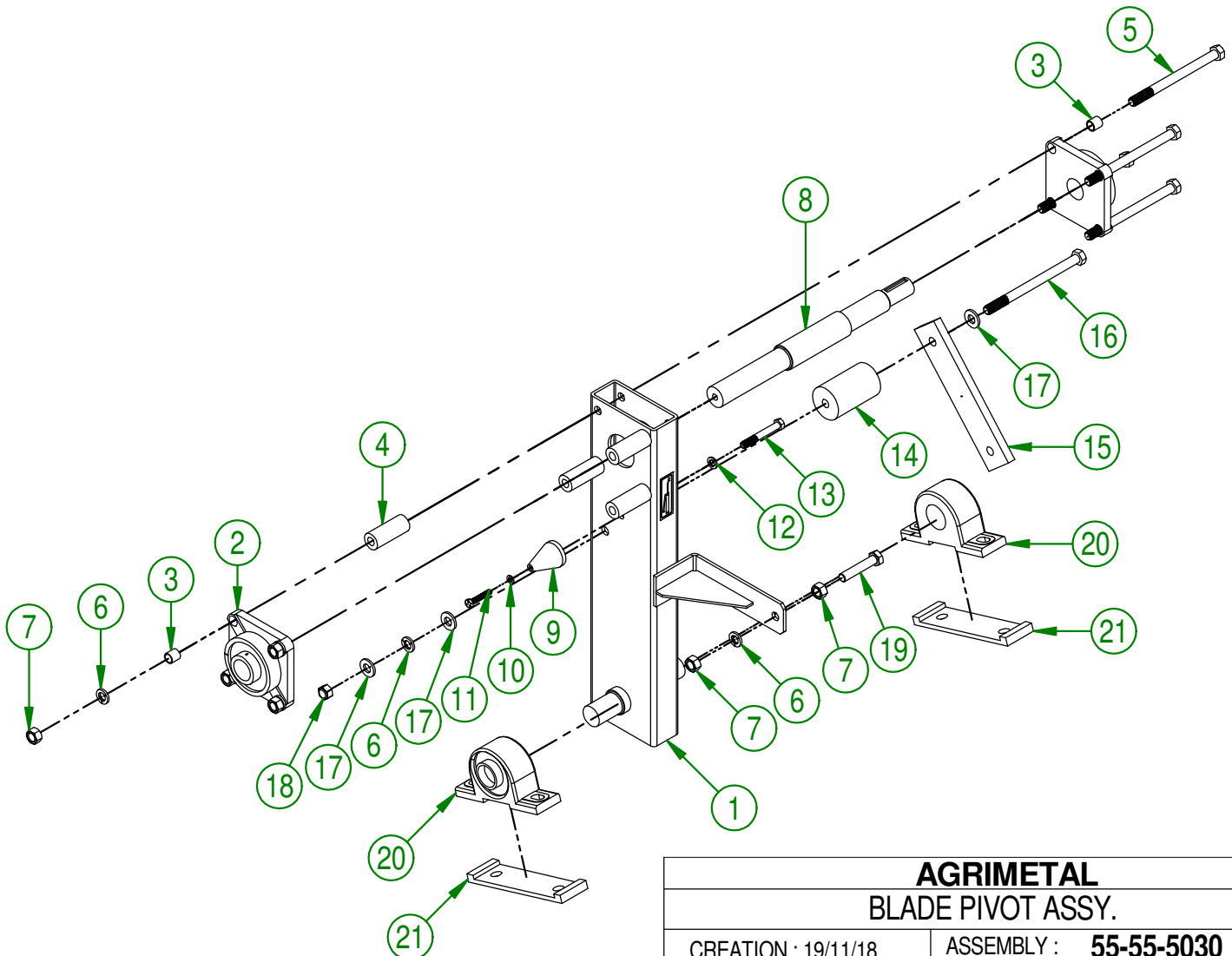

**AGRIMETAL**  
BLADE PIVOT ASSY.

CREATION : 19/11/18  
REVISION : 17/12/18

ASSEMBLY : **55-55-5030**

AUTHOR : J.KABWE

Page 5 de 17

#	PART #	Qty	TITLE
1	NC01-17-0117	4	HEX. BOLT GR2 ZINC 3/8-16 X L 3/4"
2	NC02-32-0012	4	LOCK WASHER ZINC 3/8"
3	NC02-07-0018	4	HEX. NUT ZINC 3/8-16
4	NC14-60-0003	1	CLUTCH PULLEY

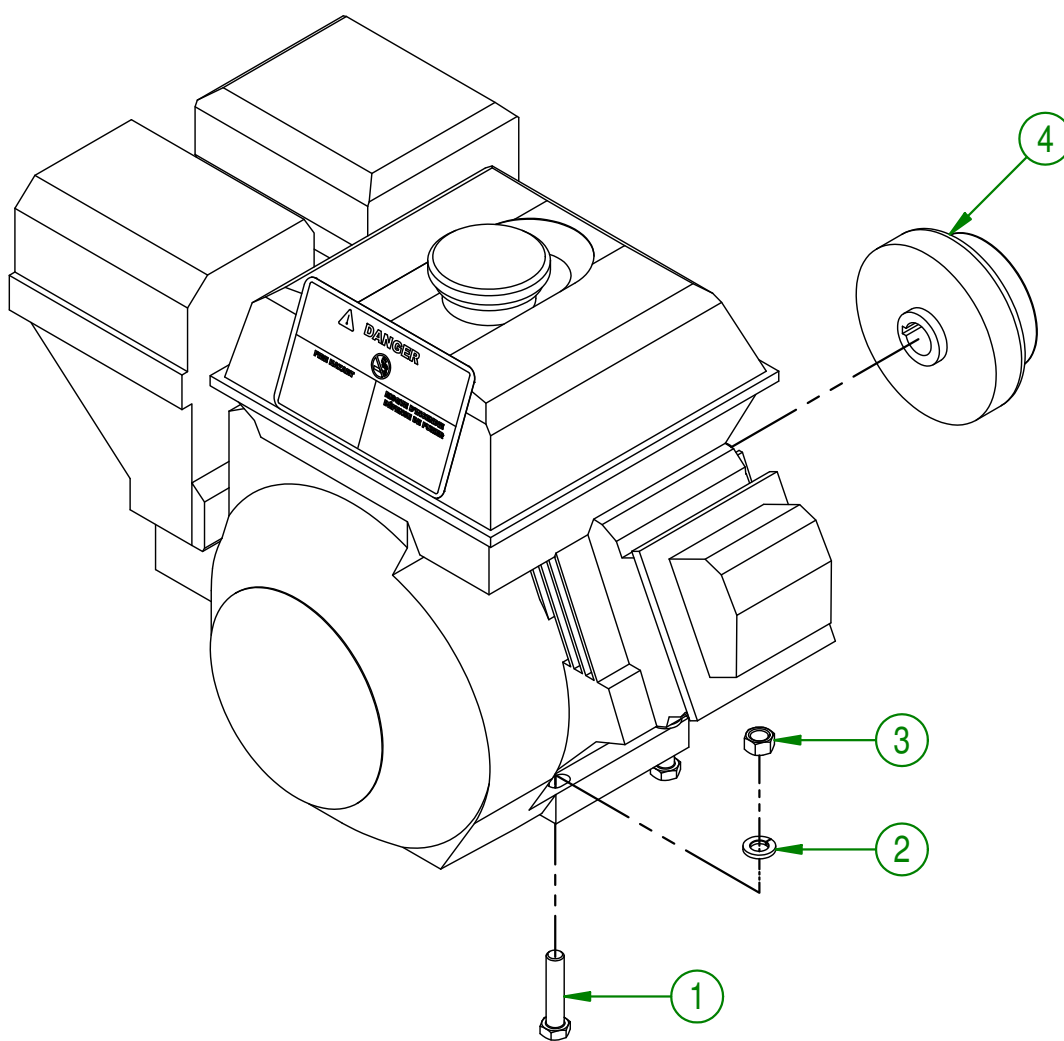

<b>AGRIMETAL</b>	
KOHLER ENGINE 7 HP GROUP	
CREATION : 19/11/18	ASSEMBLY : <b>55-57-6500</b>
REVISION : 30/08/19	AUTHOR : J.KABWE   Page 6 de 17

#	PART #	Qty	TITLE
1	55-57-5035	1	TOP BELT GUARD "INCLUDED STICKER" GROUP
2	55-01-2585	1	BELT GUARD EXTEND
3	NC01-04-0001	6	CARR. BOLT GR2 ZINC 1/4-20 X 1/2"
4	NC02-14-0017	6	FLANGED NUT GR. B 1/4-20
5	01-01-2485	4	FLAT WASHER 14 GA X 13/16"OD X 25/64" ID
6	NC02-32-0012	4	LOCK WASHER ZINC 3/8"
7	NC01-17-0119	4	HEX. BOLT GR2 ZINC 3/8-16 X 2 1/4"
8	NC17-46-0018	2	HANDLE KNOB
9	NC01-17-0125	2	HEX. BOLT GR2 NC ZINC 3/8-16 X 3 3/4"

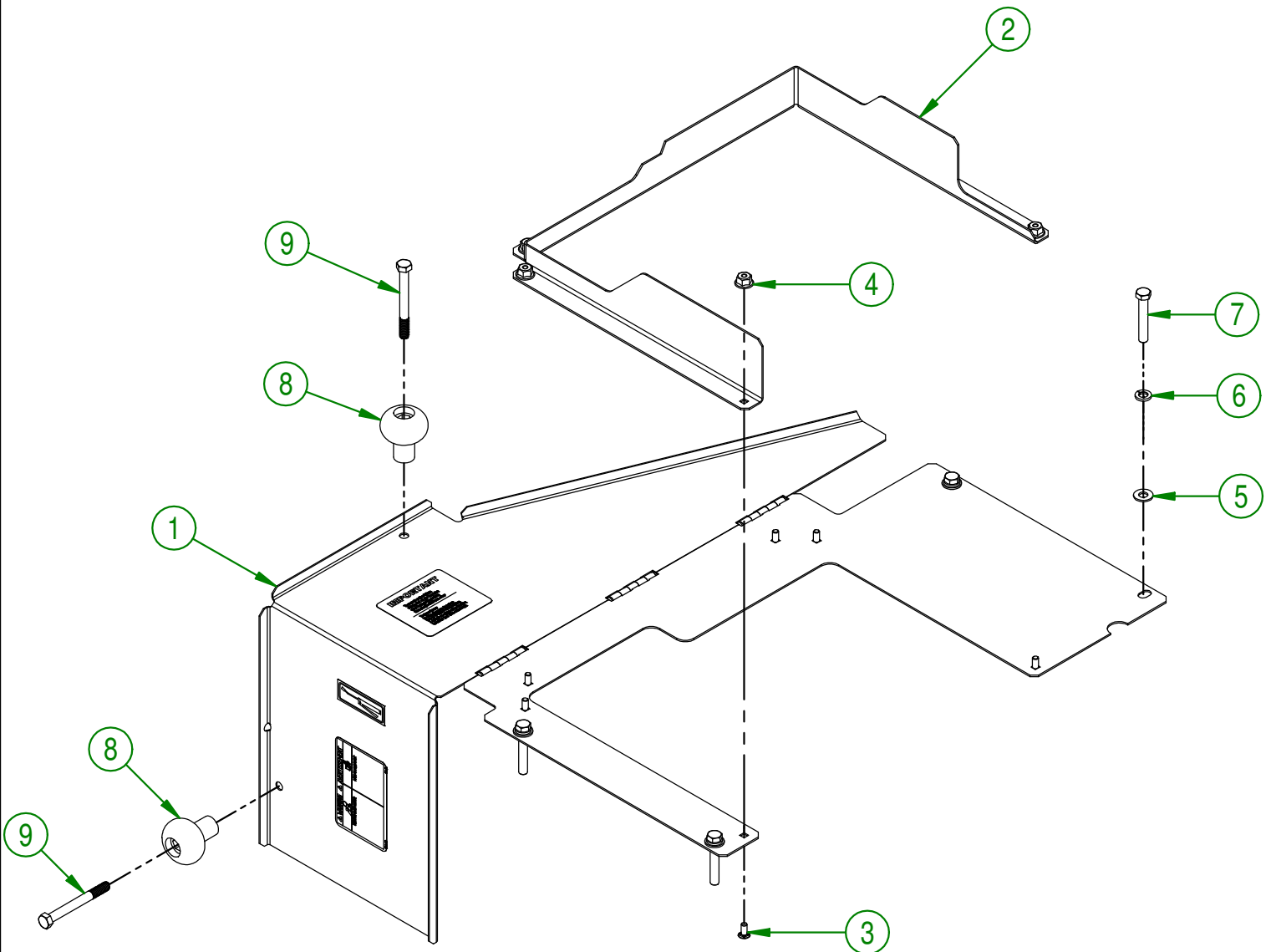

<b>AGRIMETAL</b>	
<b>TOP BELT GUARD " INCLUDED BOLT" GROUP</b>	
CREATION : 19/11/18	ASSEMBLY : <b>55-57-5040</b>
REVISION : 19/11/18	AUTHOR : J.KABWE   Page 7 de 17

#	PART #	Qty	TITLE
1	NC14-75-0033	2	MOUNTED BALL BEARINGS UCP205-16
2	01-01-0925	4	WASHER
3	NC02-32-0014	4	LOCK WASHER ZINC 1/2"
4	NC01-17-0249	4	HEX. BOLT GR2 ZINC 1/2-13 X 1 1/2"
5	NC02-07-0020	4	HEX. NUT ZINC 1/2-13
6	55-50-5025	1	HANDLE
7	NC13-15-0009	1	RUBBER HANDLE
8	NC01-17-0011	1	HEX. BOLT GR2 NC ZINC 1/4-20 X 2 1/4
9	NC02-25-0007	2	WASHER ZINC 0.281 = 9/32
10	NC01-96-0009	1	NYLON-INSERT LOCKNUT ZINC 1/4-20

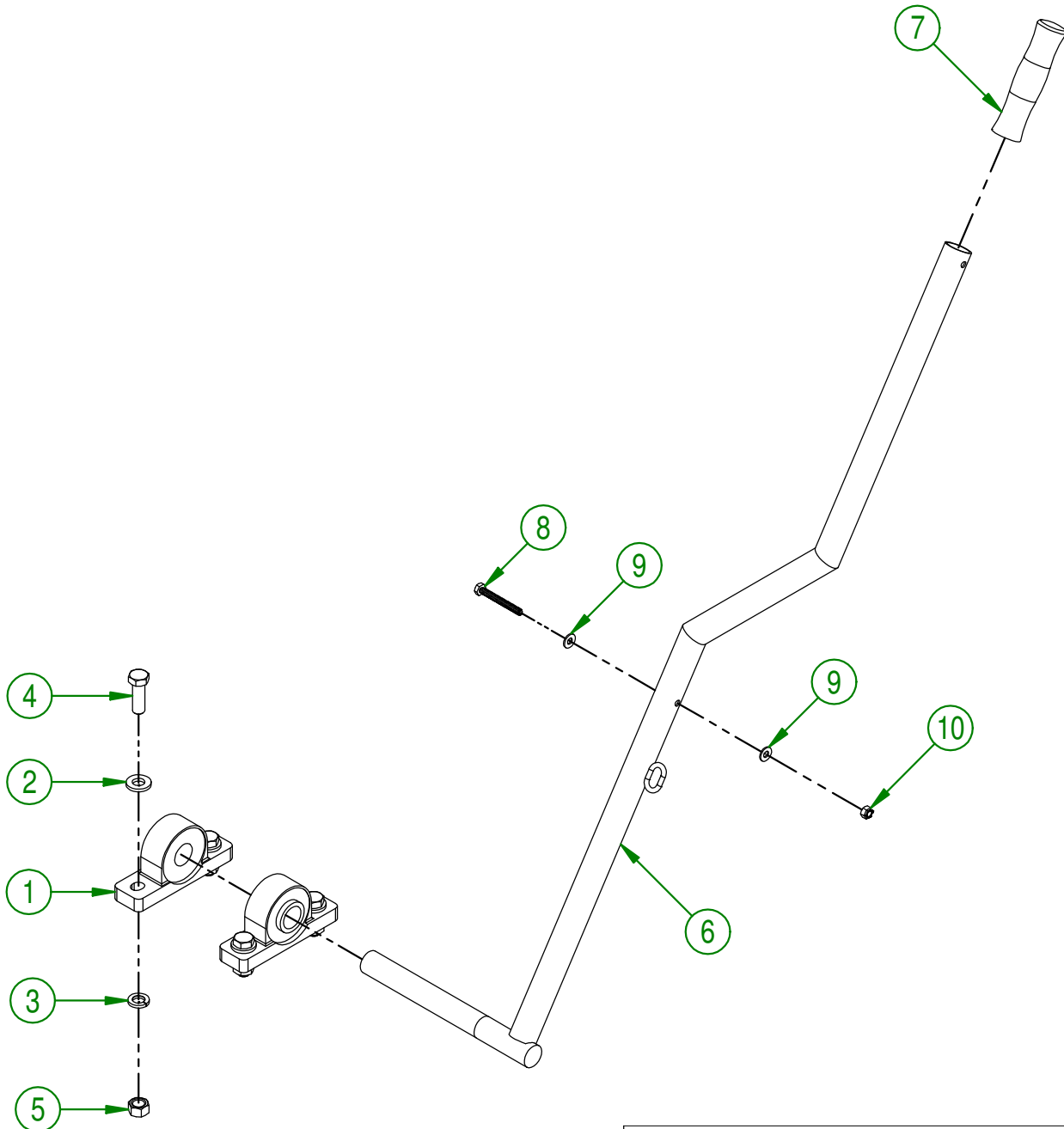

<b>AGRIMETAL</b>	
REGROUP. POIGNE & PALIER SUPPORT UCP205-16 1" DIA.	
CREATION : 19/11/18	ASSEMBLY : <b>55-57-5055</b>
REVISION : 19/11/18	AUTHOR : J.KABWE   Page 8 de 17



#	PART #	Qty	TITLE
1	NC14-63-0001	1	PULLEY PLASTIC 3 1/2" OD X BEARING 3/8"
2	55-01-2547	1	PULLEY GUARD
3	01-01-2485	1	FLAT WASHER 14 GA X 13/16"OD X 25/64" ID
4	NC01-17-0118	1	HEX. BOLT GR2 ZINC 3/8-16 X 2"
5	NC02-32-0012	1	LOCK WASHER ZINC 3/8"
6	NC02-07-0018	1	HEX. NUT ZINC 3/8-16
7	NC01-67-0102	1	INTERNALLY THREADED BALL JOINT ROD END 1/4-28
8	NC01-67-0202	1	INTERNALLY THREADED BALL JOINT ROD END 1/4-28 LH
9	NC02-14-1016	1	HEX. NUT LH NF 1/4-28
10	55-20-0255	1	CABLE ADJUSTMENT
11	NC02-10-0016	2	HEX LOCKNUT NF ZINC 1/4-28
12	NC17-02-0297	1	MBS 524 CABLE ASSY. SHORT 30"

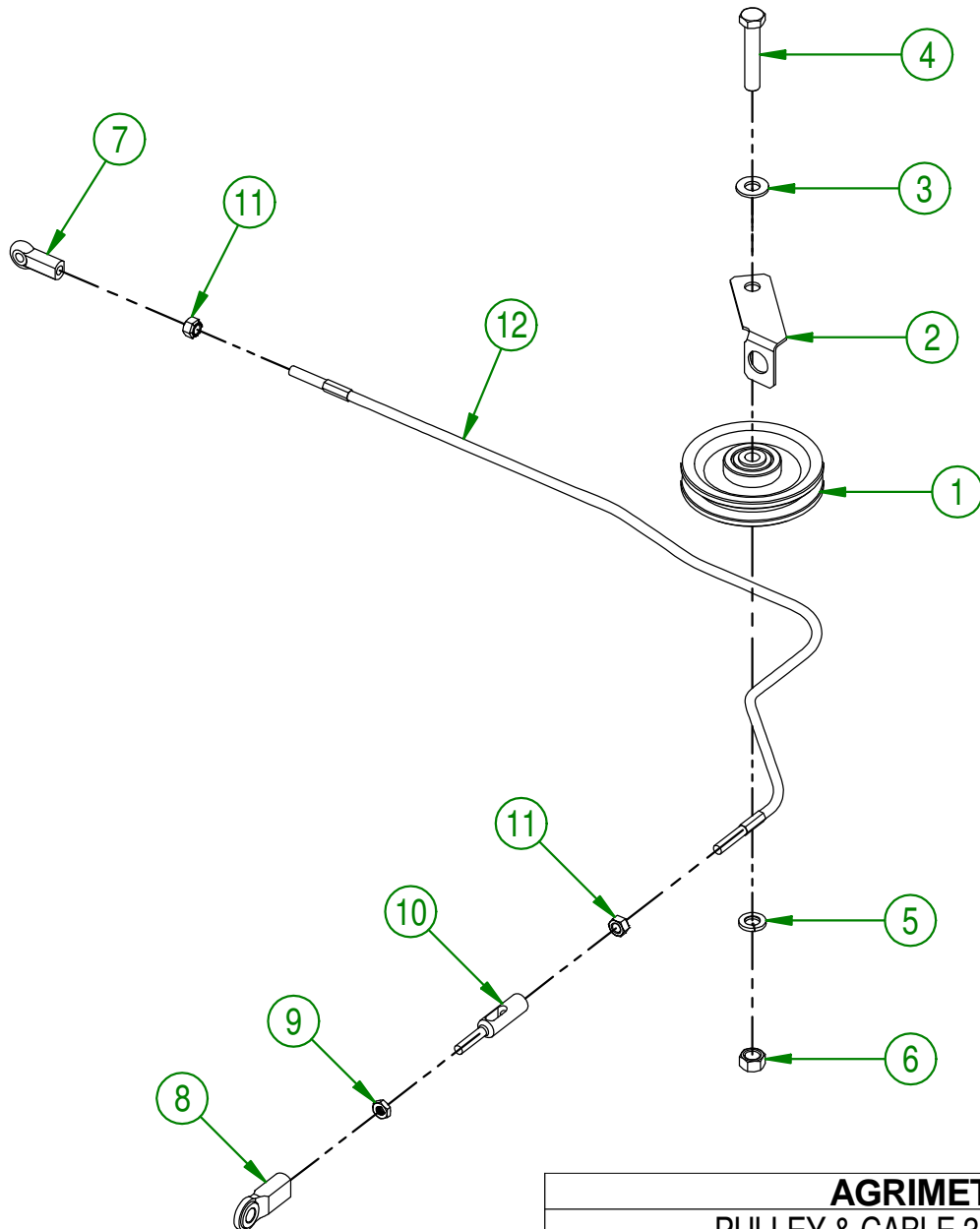

<b>AGRIMETAL</b>	
<b>PULLEY &amp; CABLE 30" GROUP</b>	
CREATION : 19/11/18	ASSEMBLY : <b>55-57-5053</b>
REVISION : 19/11/18	AUTHOR : J.KABWE Page 10 de 17

#	PART #	Qty	TITLE
1	55-50-5030	1	ACCESS DOOR
2	55-21-0000	2	ACCESS DOOR BUSHING
3	01-01-2485	3	FLAT WASHER 14 GA X 13/16"OD X 25/64" ID
4	NC01-25-0158	1	HEX. BOLT GR5 NC ZINC 3/8-16 X 11
5	NC02-32-0012	3	LOCK WASHER ZINC 3/8"
6	NC01-96-0011	1	NYLON NUT 3/8-16
7	NC01-17-0116	1	HEX. BOLT GR2 ZINC 3/8-16 X 1 1/2"
8	NC02-07-0018	2	HEX. NUT ZINC 3/8-16
9	NC13-85-0008	1	GALVANISED SPRING

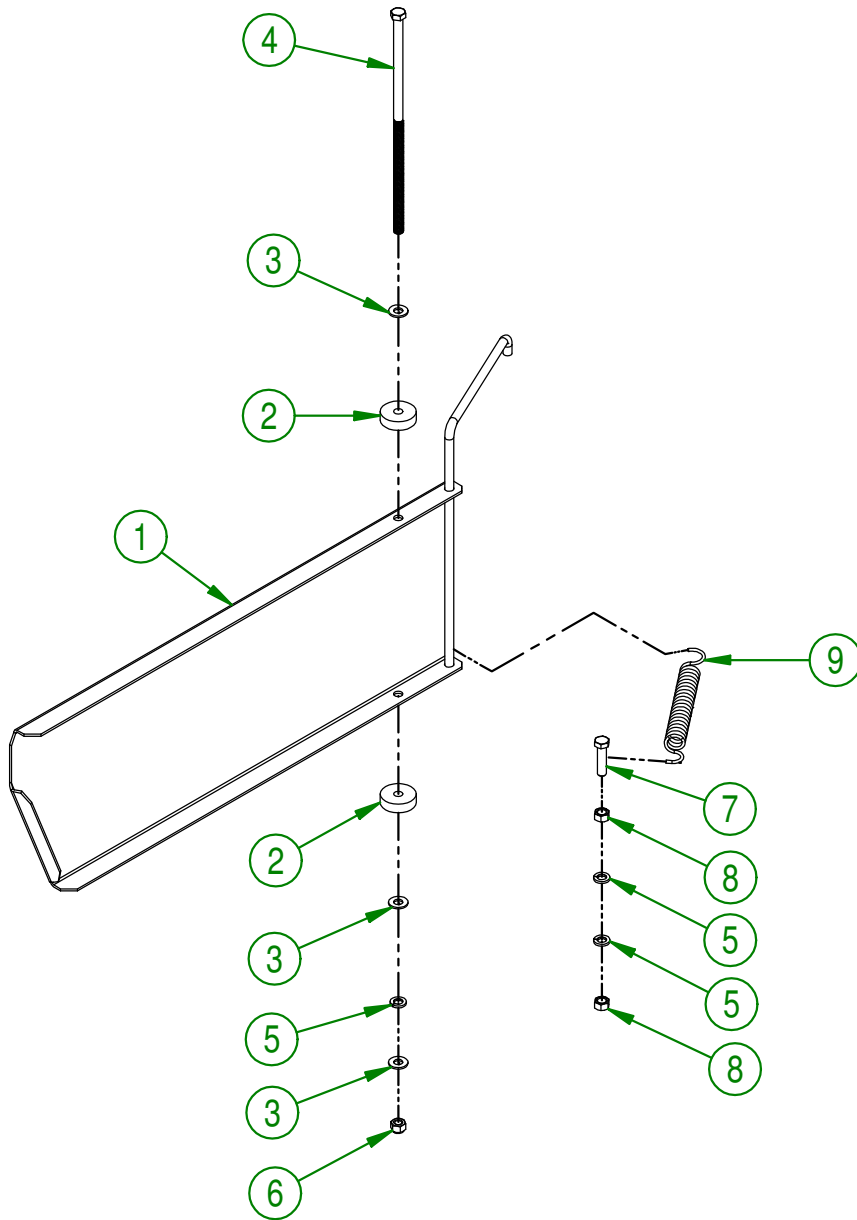

<b>AGRIMETAL</b>	
<b>SAW BENCH TABLE HARDWARE STORE GROUP</b>	
CREATION : 20/11/18	ASSEMBLY : <b>55-57-5016</b>
REVISION : 26/11/18	AUTHOR : J.KABWE   Page 11 de 17

#	PART #	Qty	TITLE
1	55-42-0125	1	ANTI-LOCK BLOCK (ENTRY)
2	NC02-36-0420	3	BRASS SLOTTED FLAT HEAD SCREW 1/4-20 X 1
3	NC01-96-0009	3	NYLON-INSERT LOCKNUT ZINC 1/4-20

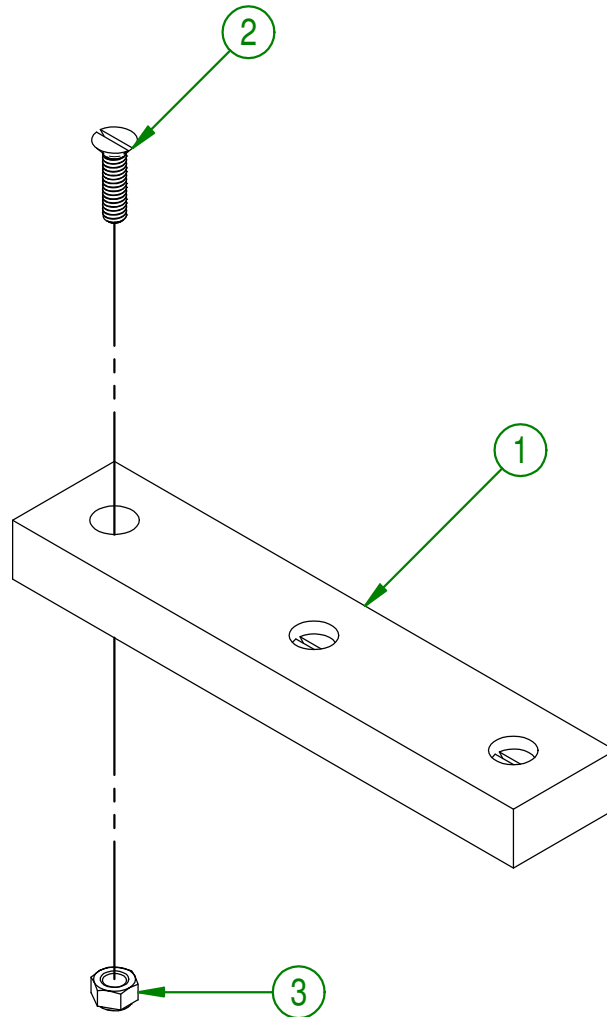

<b>AGRIMETAL</b>	
<b>BLADE GUARD ANTI-LOCK (ENTRY) GROUP</b>	
CREATION : 20/11/18	ASSEMBLY : <b>55-57-5070</b>
REVISION : 20/11/18	AUTHOR : J.KABWE   Page 12 de 17

#	PART #	Qty	TITLE
1	55-13-6005	1	SAW SUPPORT
2	55-13-6000	1	SAW SUPPORT
3	NC13-22-0023	1	CIRCULAR SAW BLADE 24" X 1 1/4" DIA. X 44 TEETH
4	NC02-11-0027	1	HEX. NUT NF ZINC 1 1/4-12 GR8

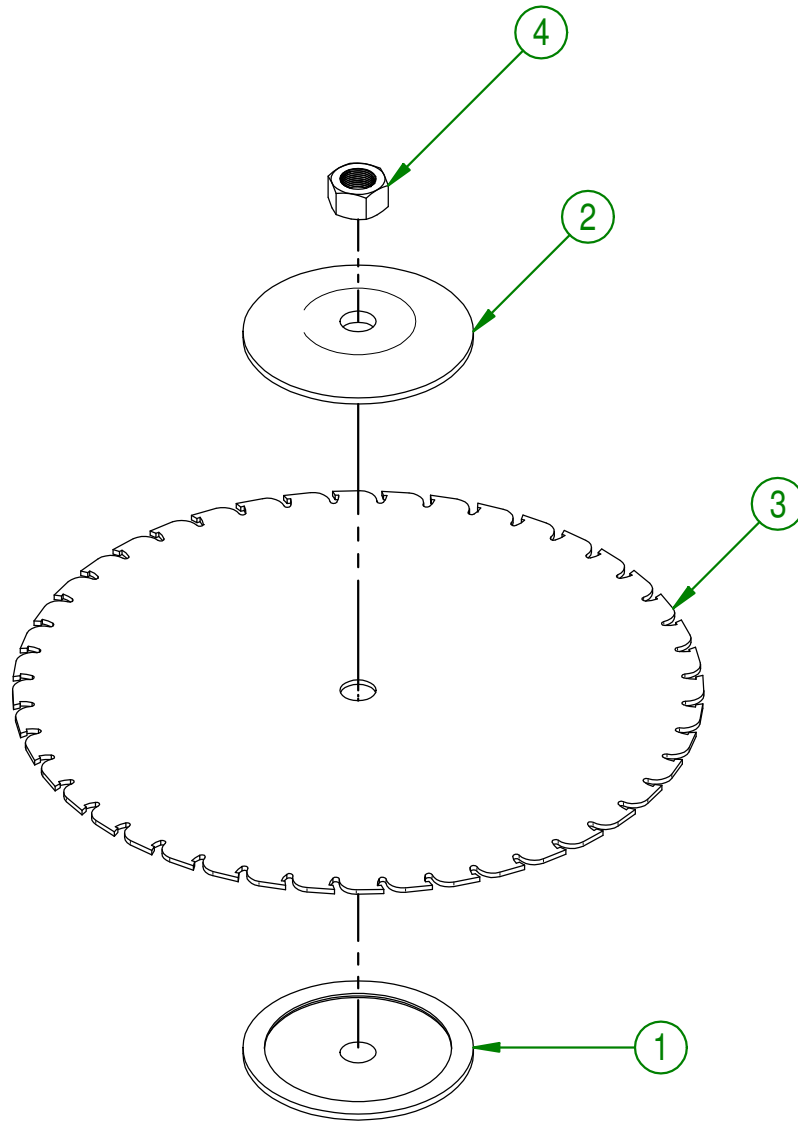

<b>AGRIMETAL</b>	
<b>SAW BLADE GROUP</b>	
CREATION : 20/11/18	ASSEMBLY : <b>55-57-5075</b>
REVISION : 20/11/18	AUTHOR : J.KABWE   Page 13 de 17

#	PART #	Qty	TITLE
1	55-55-5010	1	BLADE GUARD ASSY.
2	NC01-04-0014	8	CARR. BOLT GR2 ZINC 1/4-20 X 2 1/2"
3	NC01-04-0018	3	CARR. BOLT GR2 NC ZINC 1/4-20 X 2 3/4"
4	NC01-96-0009	11	NYLON-INSERT LOCKNUT ZINC 1/4-20

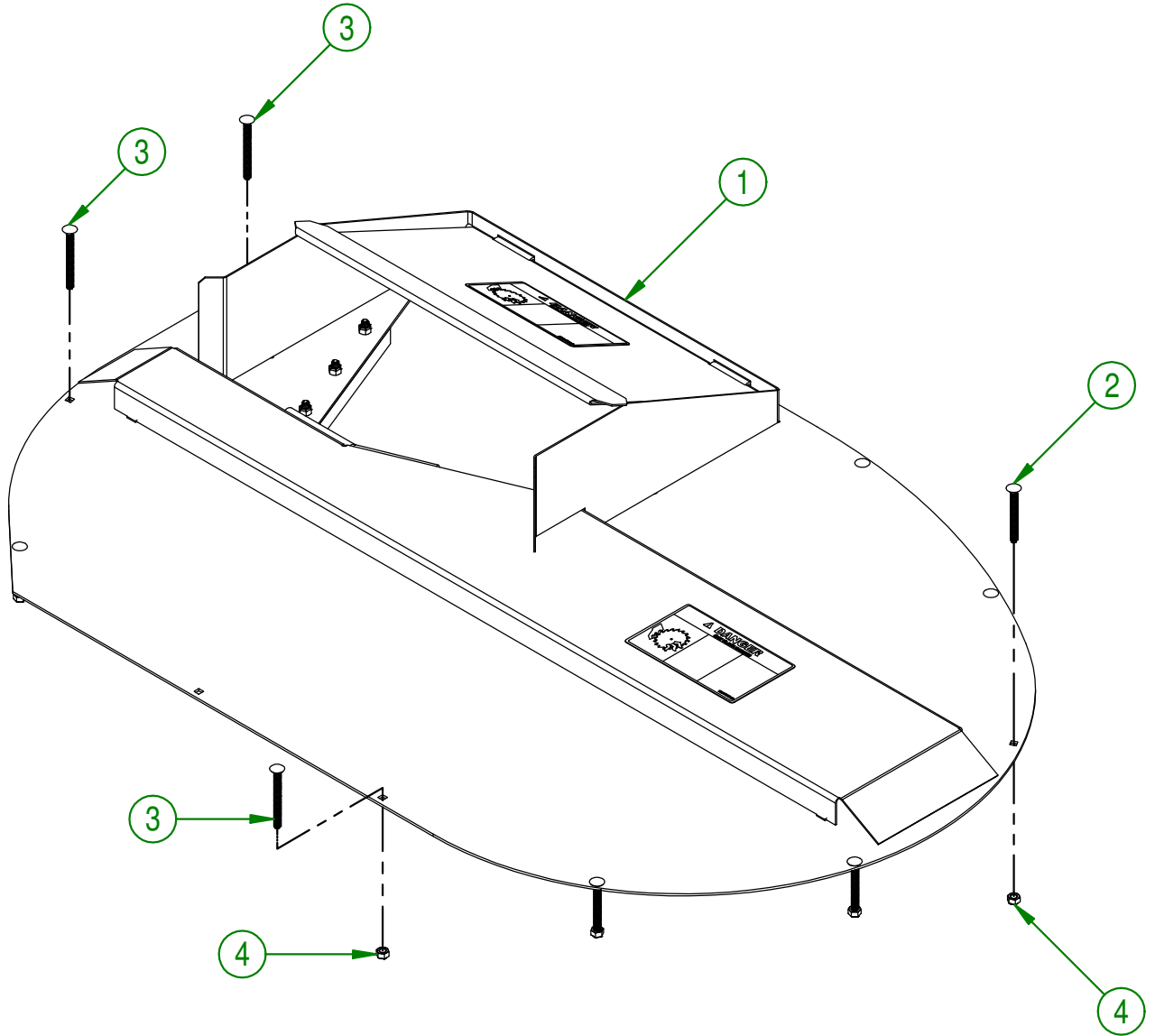

<b>AGRIMETAL</b>	
<b>BLADE GUARD "INCLUDED BOLT" GROUP</b>	
CREATION : 19/11/18	ASSEMBLY : <b>55-57-5095</b>
REVISION : 26/11/18	AUTHOR : J.KABWE   Page 14 de 17

#	PART #	Qty	TITLE
1	55-57-5090	1	BLADE GUARD "INCLUDED STICKER" GROUP
2	55-42-0120	1	BLADE GUARD LIMITER (OUTPUT)
3	NC02-36-0420	4	BRASS SLOTTED FLAT HEAD SCREW 1/4-20 X 1
4	NC01-96-0009	4	NYLON-INSERT LOCKNUT ZINC 1/4-20

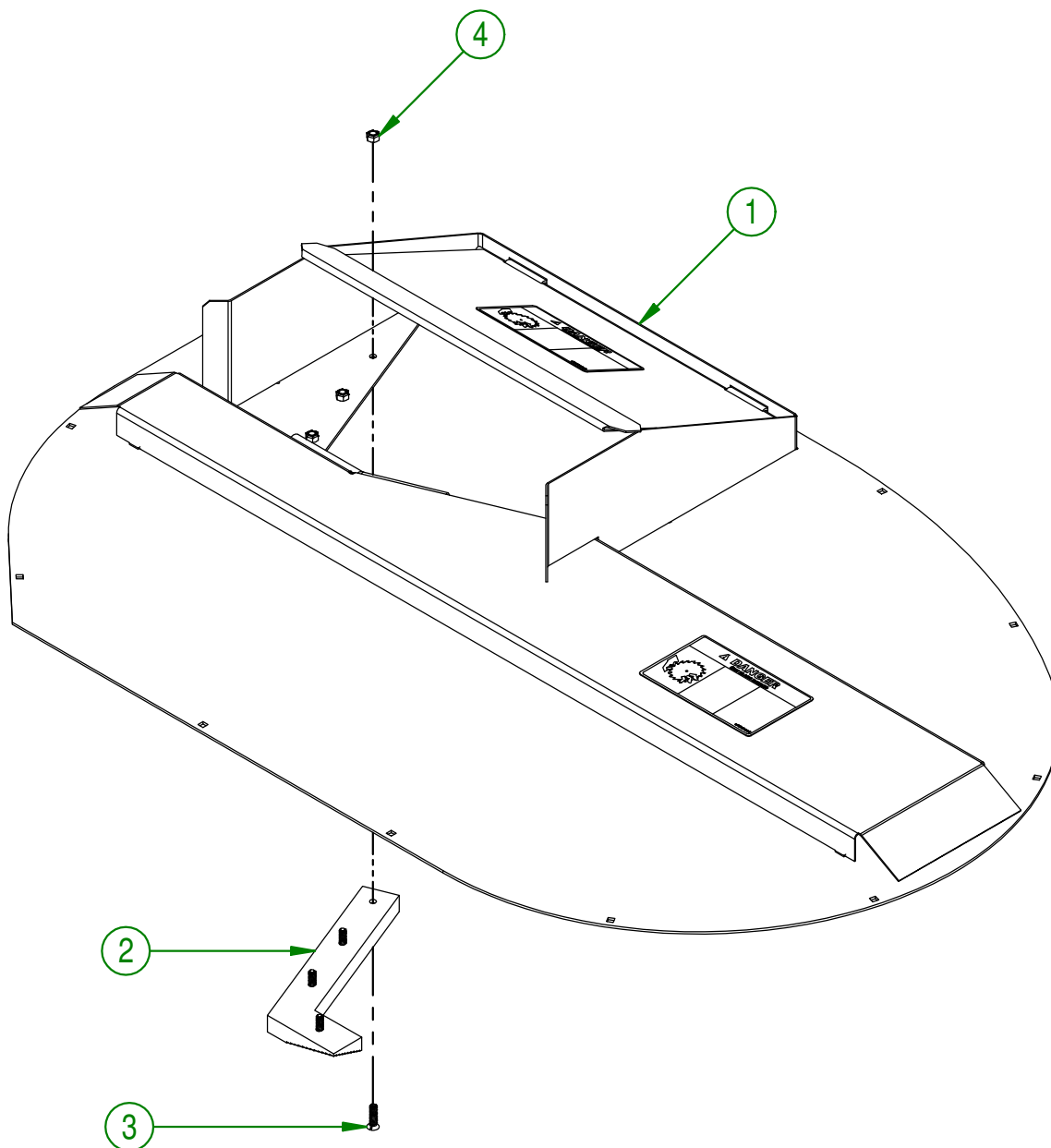

<b>AGRIMETAL</b>	
<b>BLADE GUARD ASSY.</b>	
CREATION : 19/11/18	ASSEMBLY : <b>55-55-5010</b>
REVISION : 26/11/18	AUTHOR : J.KABWE   Page 15 de 17

#	PART #	Qty	TITLE
1	55-50-5015	1	CUTTING GUIDE
2	NC17-46-0018	1	HANDLE KNOB
3	NC01-17-0134	1	HEX. BOLT GR2 NC ZINC 3/8-16 X 6
4	NC02-07-0018	1	HEX. NUT ZINC 3/8-16

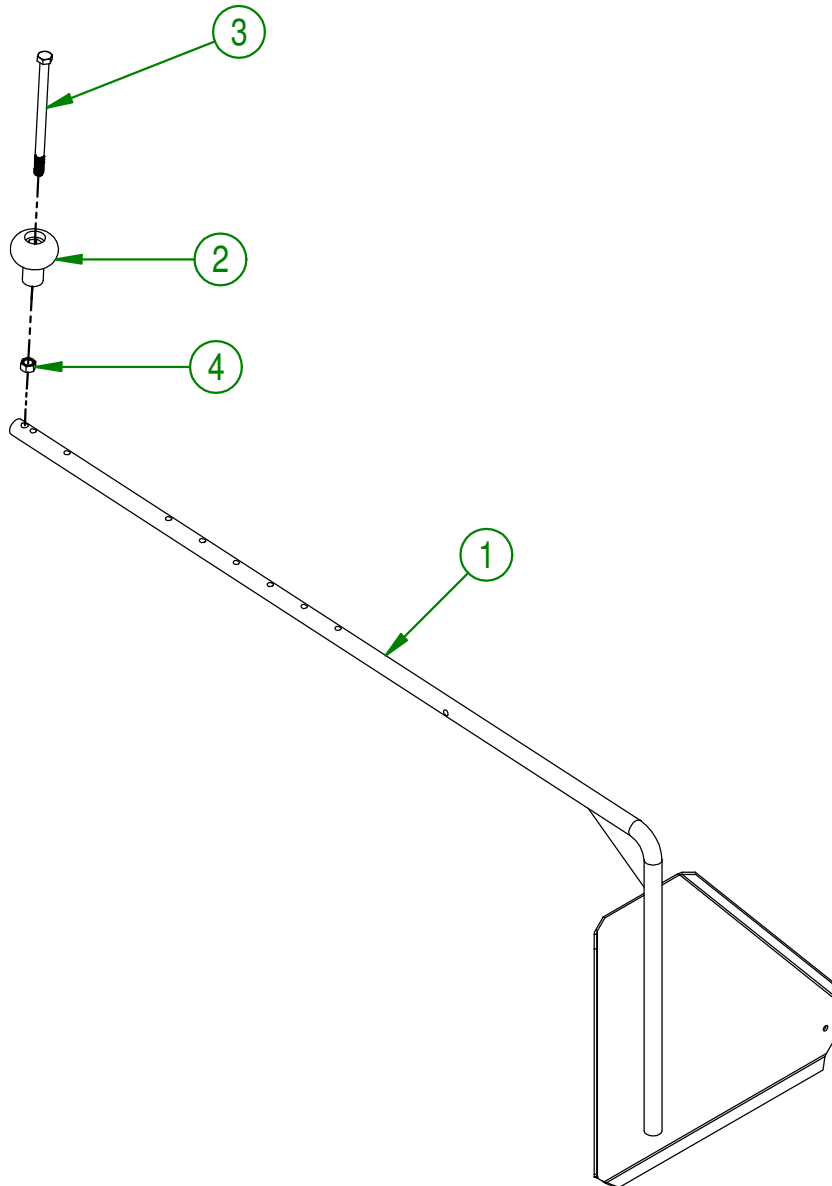

<b>AGRIMETAL</b>	
<b>CUTTING GUIDE &amp; CUTTING HANDLE GROUP</b>	
CREATION : 20/11/18	ASSEMBLY : <b>55-57-5100</b>
REVISION : 20/11/18	AUTHOR : J.KABWE   Page 16 de 17

#	PART #	Qty	TITLE
1	NCI3-33-0024	6	STICKER GREASE HERE
2	NCI3-33-0009	2	SITCKER WARNING
3	NCI3-33-0113	1	STICKER WARNING
4	NCI3-33-0001	2	STICKER AGRIMETAL
5	NCI3-33-0172	1	STICKER CAUTION
6	NCI3-33-0173	3	STICKER DANGER
7	NCI3-33-0149	2	STICKER RED REFLECTOR
8	NCI3-33-0180	1	STICKER IMPORTANT
9	NCI3-33-0109	1	STICKER DANGER NO SMOKING
10	NCI3-33-0017	1	STICKER WARNING
11	NCI3-33-0151	1	STICKER (IMPORTANT TO PREVENT ENGINE FAILURE...)

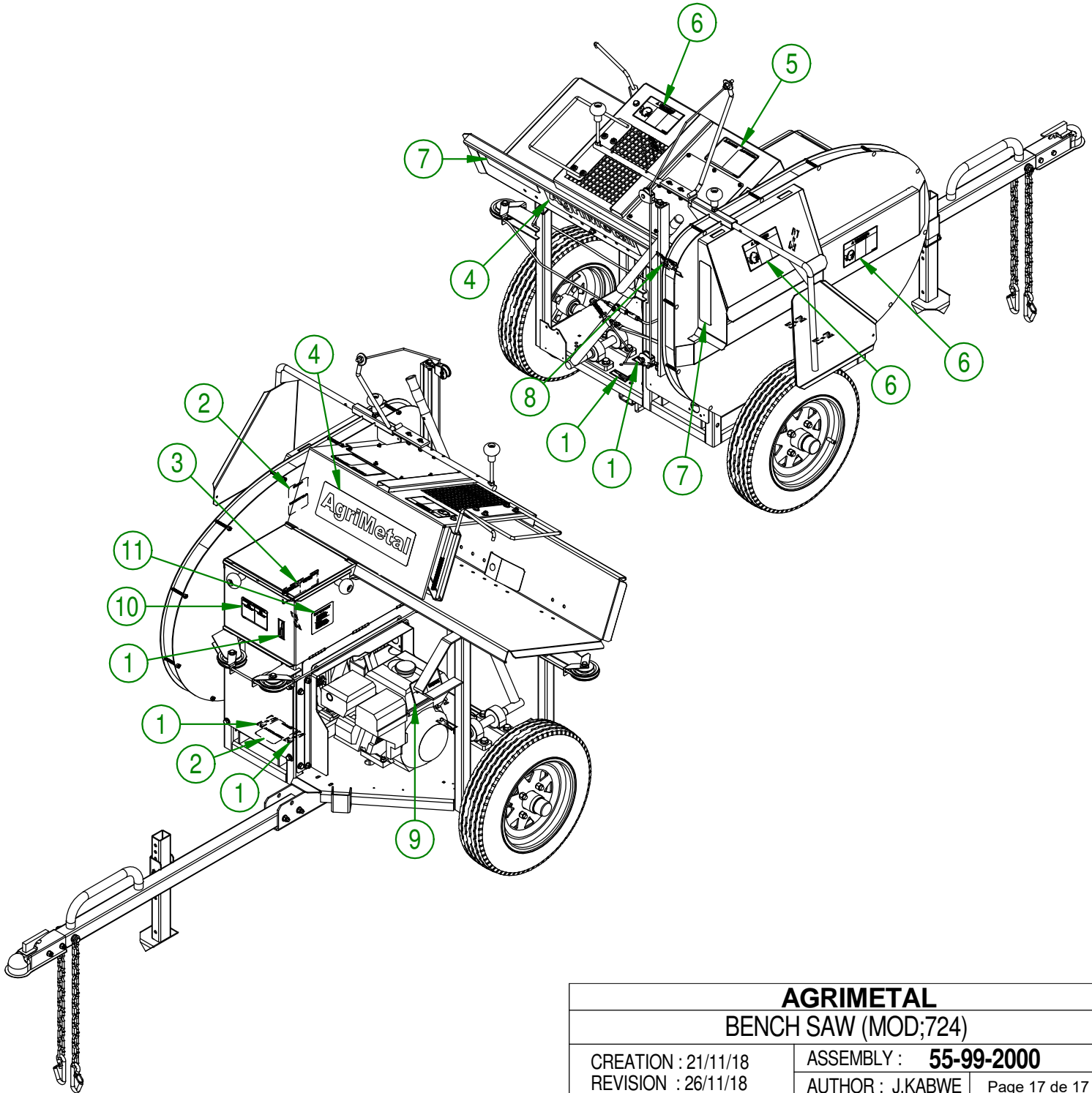

<b>AGRIMETAL</b>	
<b>BENCH SAW (MOD;724)</b>	
CREATION : 21/11/18	ASSEMBLY : <b>55-99-2000</b>
REVISION : 26/11/18	AUTHOR : J.KABWE Page 17 de 17