

AgriMetal

PARTS LIST

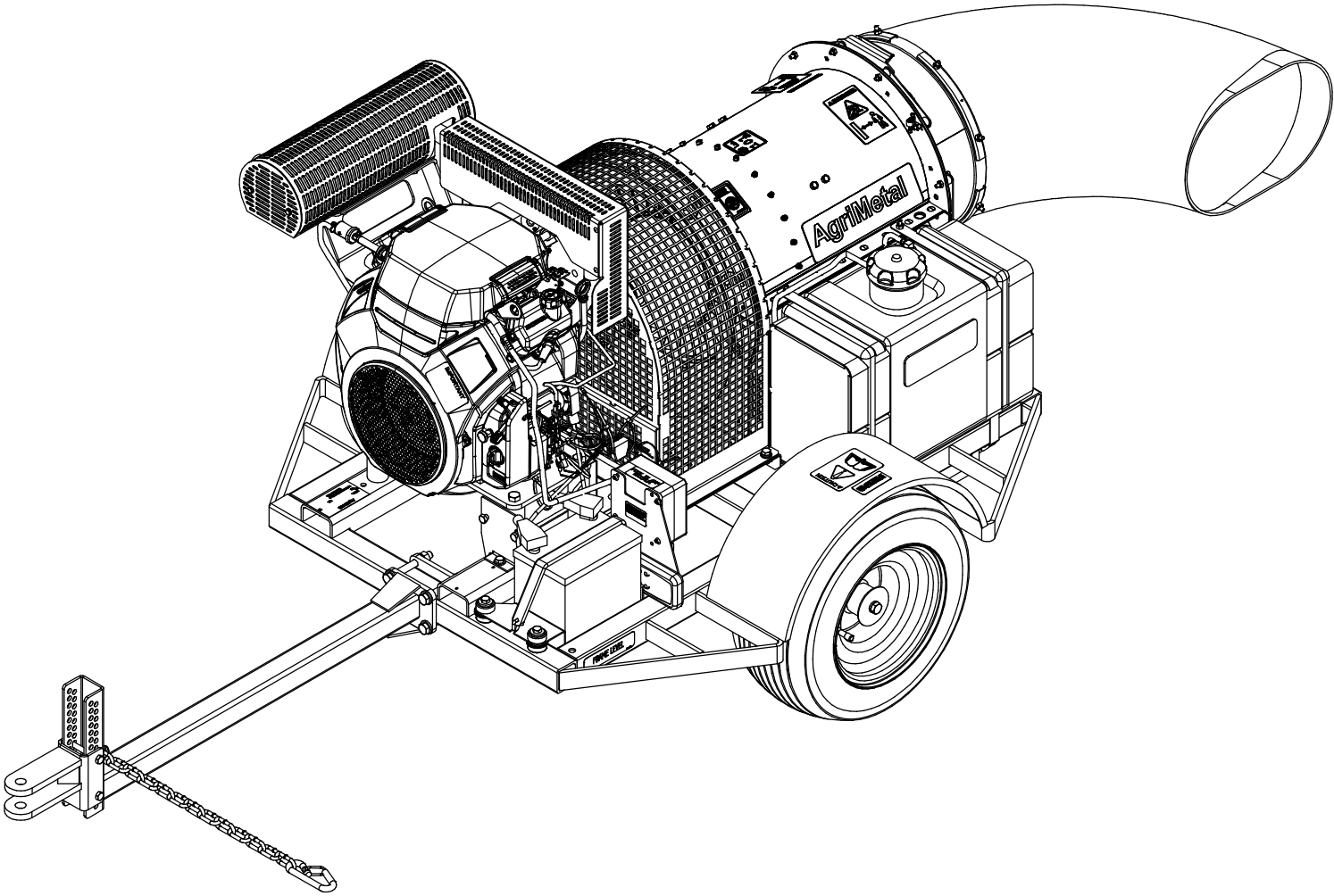

TURBINE BLOWER 240-B

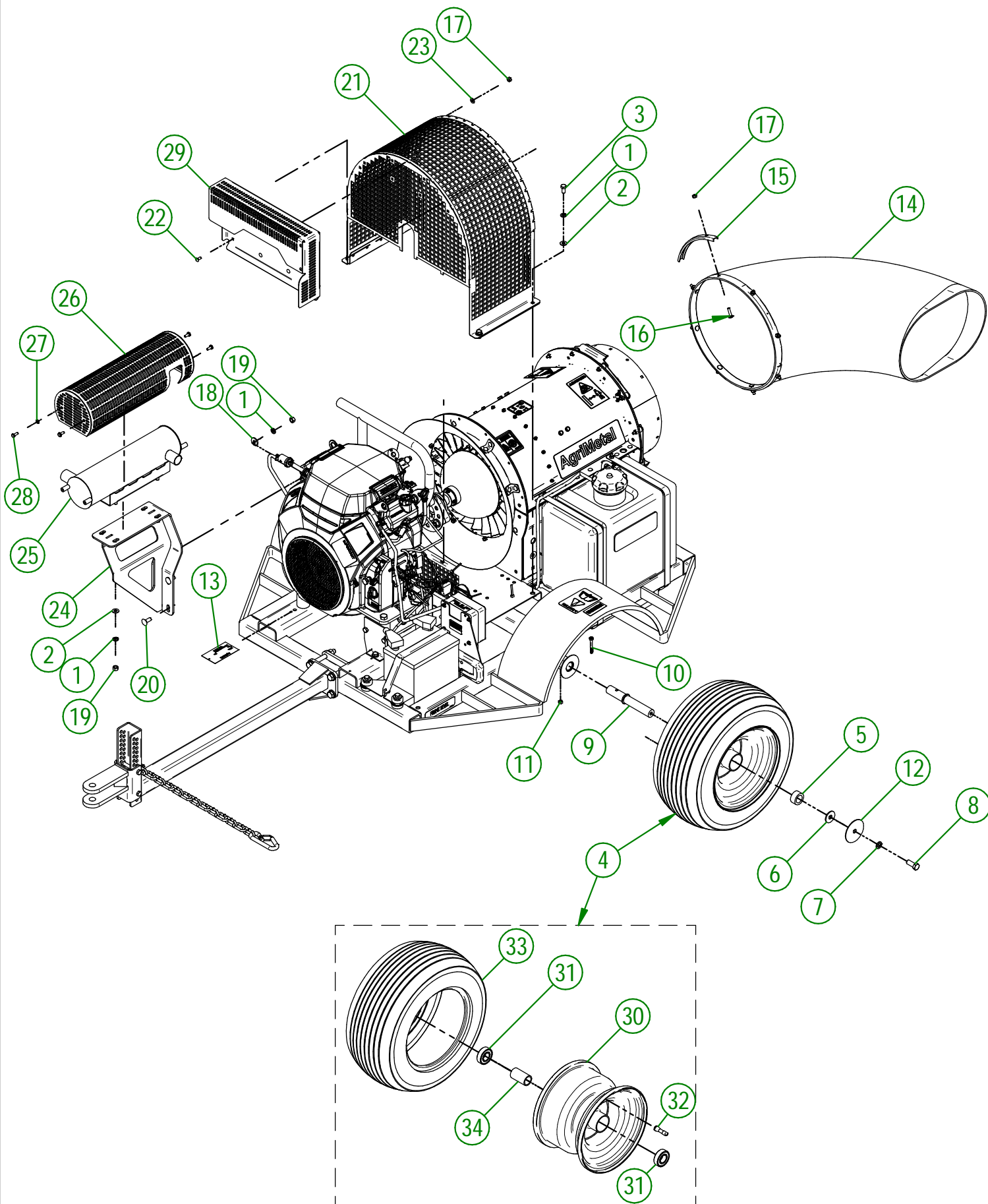

AGRIMETAL

TURBINE BLOWER 240-B

CREATION : 25/06/24
 REVISION : 25/06/24

ASSEMBLY : **33-99-3101**
 AUTHOR : dessin3

33-99-3101

#	PART #	QTY	TITLE
1	NC02-32-0012	12	LOCK WASHER ZINC 3/8"
2	01-01-2485	10	FLAT WASHER 14 GA X 13/16"OD X 25/64" ID
3	NC01-17-0112	4	HEX. BOLT GR2 ZINC 3/8-16 X 3/4"
4	33-55-0125	2	ASSEMBLY WHEEL 18X9.50-8 WITH BALL BEARING
5	33-21-0065	2	WHEEL BUSHING
6	01-01-1660	2	WASHER SPACER
7	NC02-32-0014	2	LOCK WASHER ZINC 1/2"
8	NC01-17-0248	2	HEX. BOLT GR2 ZINC 1/2-13 X 1 1/4"
9	33-13-0100	2	AXLE SHAFT
10	NC01-33-0010	2	GRADE 8 HEX HEAD SCREW 1/4-20 X 2" LG.
11	NC01-93-0001	2	HEX. LOCK NUT NC ZINC 1/4-20
12	33-01-0400	2	BEARING SHEILD
13	NC13-50-0086	1	SERIAL NUMBER PLATE
14	33-42-0005	1	90° PLASTIC ELBOW
15	33-01-2480	4	DUCT CLAMP
16	NC01-04-0005	8	CARR. BOLT GR2 ZINC 1/4-20 X 1"
17	NC01-96-0009	14	NYLON-INSERT LOCKNUT ZINC 1/4-20
18	21-01-0950	4	FLAT WASHER 10GA 1.005" DIA X 25/64"
19	NC02-07-0018	8	HEX. NUT ZINC 3/8-16
20	NC01-04-0109	4	CARR. BOLT GR2 ZINC 3/8-16 X 1"
21	33-50-0035	1	TURBINE GUARD (TB-270-240)
22	NC01-04-0001	6	CARR. BOLT GR2 ZINC 1/4-20 X 1/2"
23	NC02-22-0008	6	WASHER ZINC 5/16"
24	22-50-0301	1	EXHAUST SUPPORT (GX690 24HP)
25	33-50-1050	1	27 HP KOHLER MUFFLER
26	33-50-1055	1	MUFFLER GUARD (27 HP KOHLER)
27	NC02-32-0010	4	LOCK WASHER ZINC 1/4"
28	NC01-29-0003	4	HEX. BOLT GR5 ZINC 1/4-28 X 5/8"
29	33-55-1560	1	EXHAUST GUARD

33-55-0125

#	PART #	QTY	TITLE
30	NC14-70-0320	1	RIM FOR NC14-70-0317
31	NC14-55-0330	2	6205-2RSI BEARING
32	NC14-70-0322	1	VALVE FOR NC14-70-0317
33	NC14-70-0319	1	WHEEL 18X9.50-8 (TURBINE)
34	33-10-0015	1	INSIDE WHEEL SPACER

#	PART #	QTY	TITLE
1	NCI3-25-0369	1	ELECTRIC BOX TB 270
2	NC02-42-0096	4	PHILLIPS SCREW ZINC #14 X 5/8"
3	NCI3-15-0055	1	INSULATING ROLLED COLLAR 7/16"ID X 15/16"OD X 5/16"T
4	NCI3-25-0019	10	BLACK TIE RAP
5	33-22-2240	1	WIRE PROTECTOR
6	NCI3-25-0374	1	WIRE 46"(NEW BOX)
7	33-55-0045	1	DEFLECTOR ELECTRIC MOTOR
8	33-57-0076	1	REMOTE CONTROL GROUP.

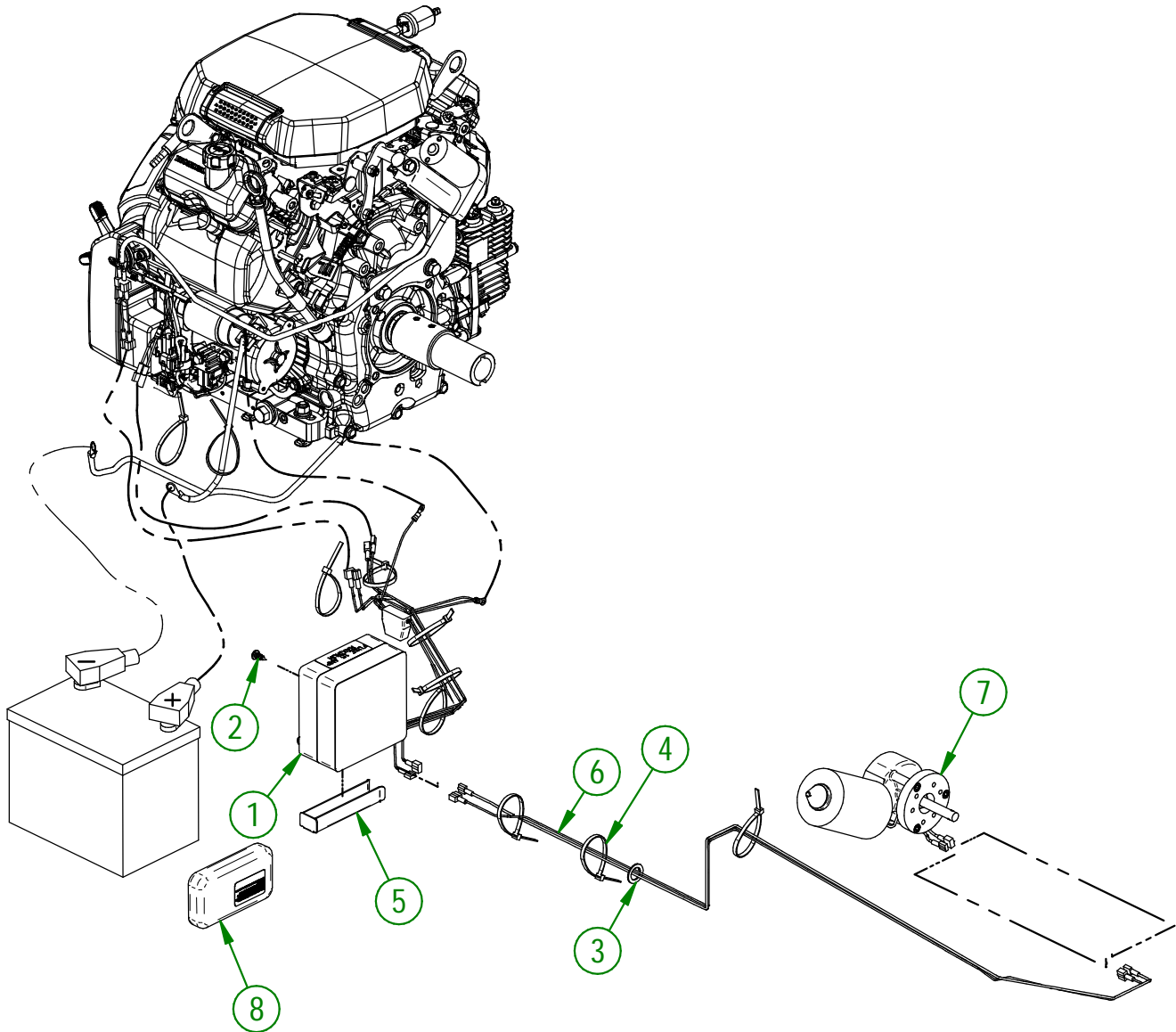
**AGRIMETAL**

TURBINE BLOWER 240 CARB

CREATION : 26/06/24
 REVISION : 26/06/24

ASSEMBLY : **33-99-3101**
 AUTHOR : D. CHASSÉ

TB 240

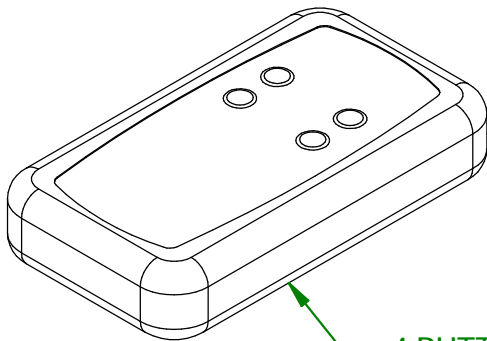
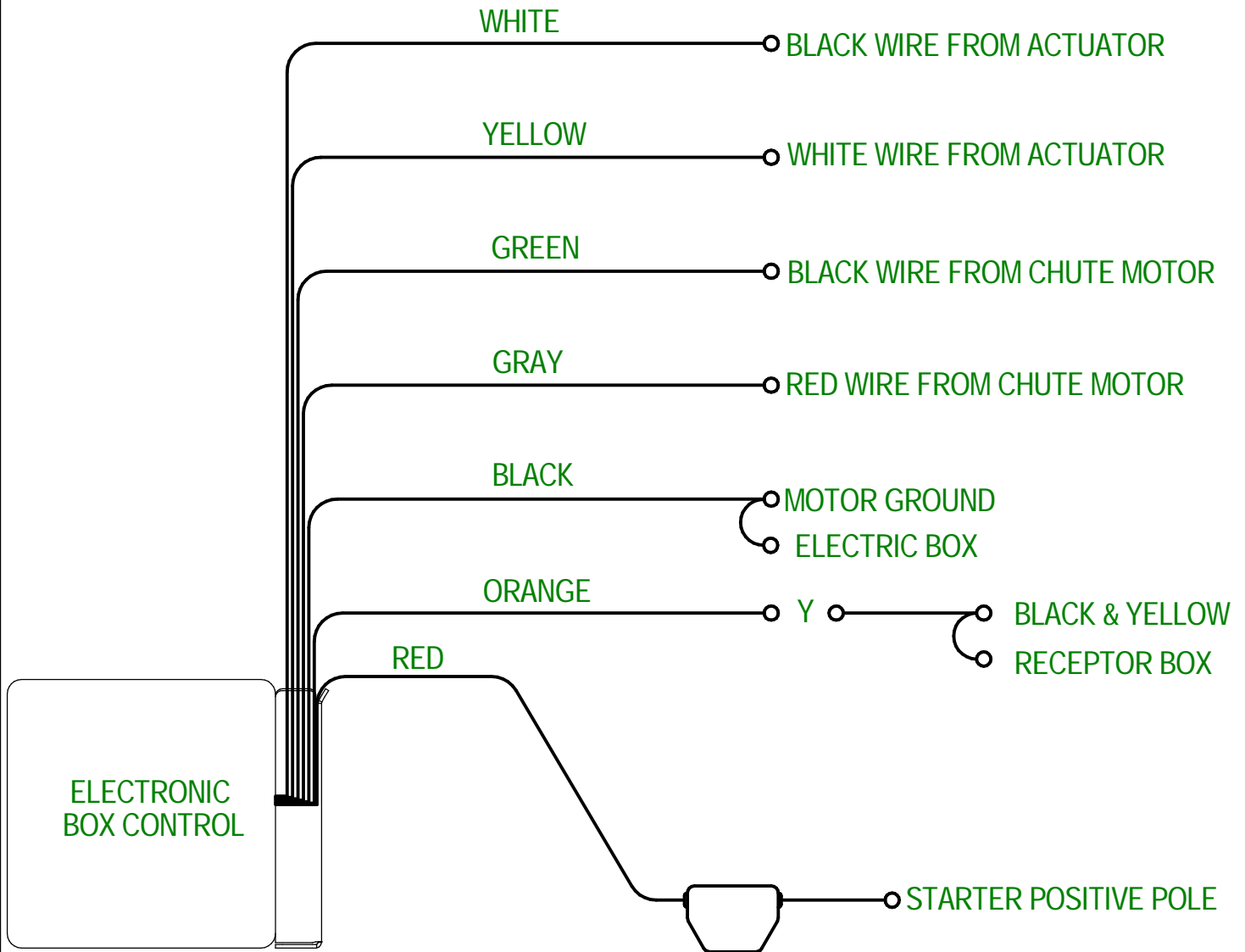

4 BUTTONS REMOTE CONTROL

AGRIMETAL	
ELECTRONIC BOX CONTROL GROUP.	
CREATION : 12/02/24	ASSEMBLY : 33-57-0006
REVISION : 16/02/24	AUTHOR : J.KABWE

#	PART #	Qty	TITLE
1	33-01-3045	2	GAS TANK STRAP
2	33-46-0590	1	GAS VENT HOSE 1/2" DIA.X 1/4" D.I. X 64"
3	33-46-0661	1	GAS HOSE 1/2" DIA.X 1/4" D.I. X 70"
4	33-55-0200	1	GAS TANK
5	33-55-0205	1	GAS CAP
6	NC01-04-0002	4	CARR. BOLT GR2 ZINC 1/4-20 X 5/8"
7	NC01-65-0201	2	SPRING -GRIP HOSE CLAMPS 1/2" O.D
8	NC01-96-0009	4	NYLON-INSERT LOCKNUT ZINC 1/4-20
9	NCI3-25-0019	3	BLACK TIE RAP

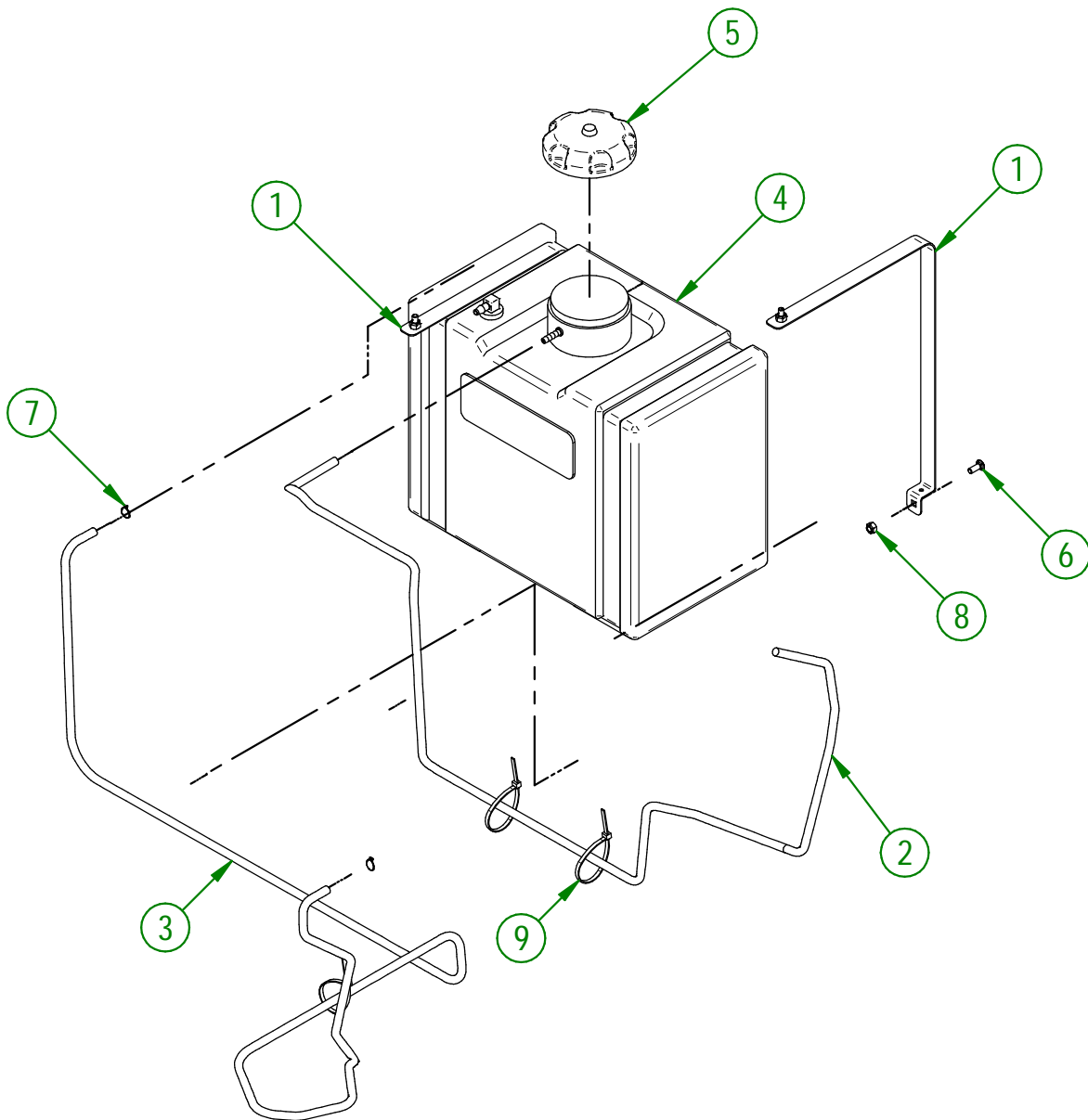

AGRIMETAL	
GAS TANK ASSEMBLY (TB240)	
CREATION : 24/04/24	ASSEMBLY : 33-57-0134
REVISION : 21/08/25	AUTHOR : D. CHASSÉ

33-57-2510

#	PART #	Qty	TITLE
1	33-57-2501	1	ASSEMBLY FRAME STICKER INCLUDED
2	33-01-0085	1	HONDA BOX BRACKET
3	NC01-25-0114	1	HEX. BOLT GR2 ZINC 3/8-16 X 1"
4	NC02-25-0009	1	WASHER 0.406" I.D. X 0.815 O.D.
5	NC02-32-0012	1	LOCK WASHER ZINC 3/8"
6	NC01-93-0011	3	LOCK NUT 3/8-16
7	NC01-24-0007	2	HEX. BOLT GR5 BLACK 3/8-16 X 3/4"
8	NC01-96-0009	2	NYLON-INSERT LOCKNUT ZINC 1/4-20
9	33-57-0210	1	ENGINE BASE GROUP
10	NC01-37-0267	4	HEX. BOLT GR8 ZINC 1/2-20 X 6" LG
11	NC02-22-0012	4	WASHER ZINC 1/2 BOLT = 9/16"Ø X 1 3/8" OD
12	NC01-94-0013	4	NYLON NUT ZINC 1/2-20"
13	33-01-0330	1	SHIELD PLATE
14	NC01-07-0107	2	CARR. BOLT GR2 ZINC 3/8-16 X 3/4"
15	01-01-2485	2	FLAT WASHER 14 GA X 13/16"OD X 25/64" ID

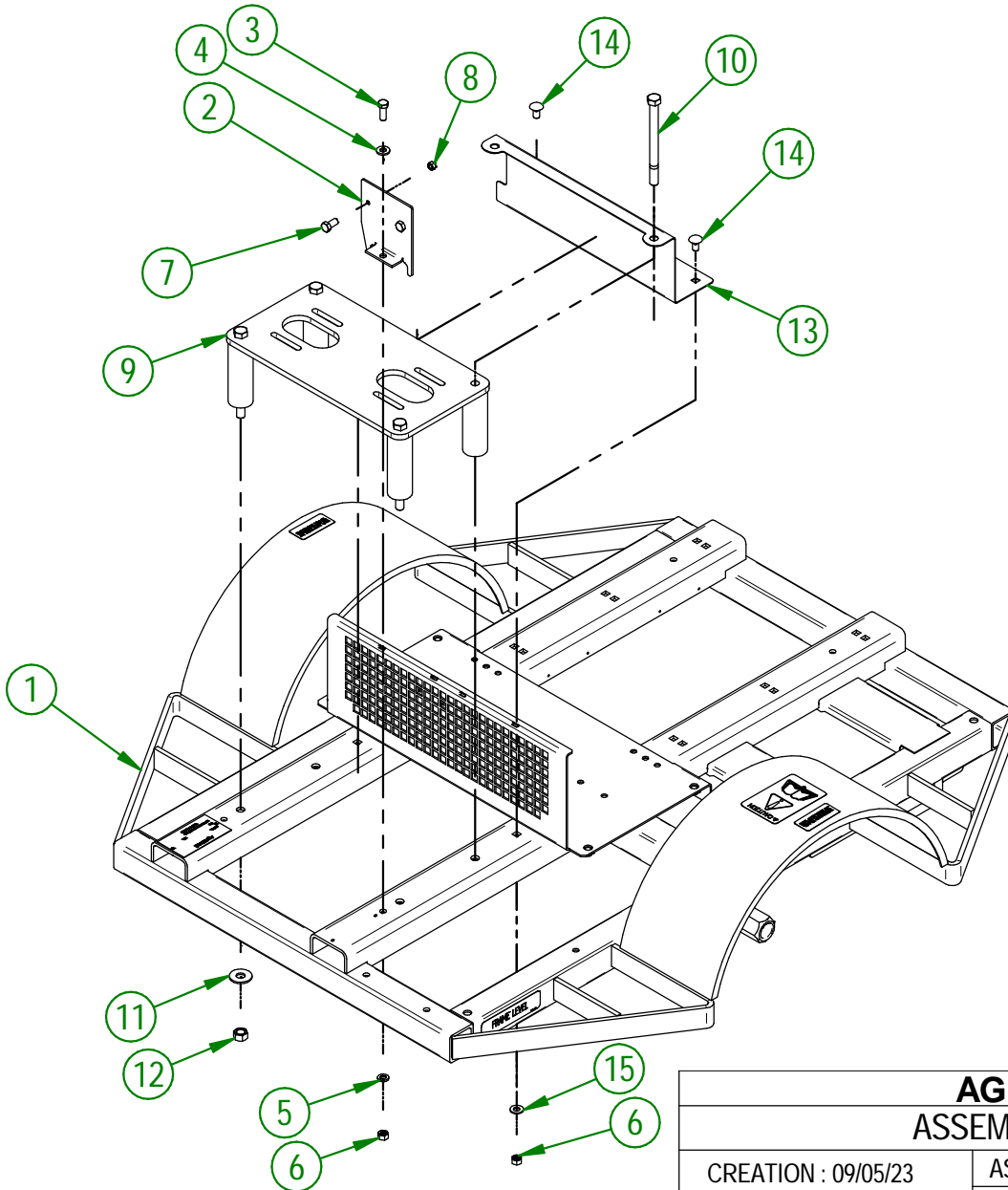

AGRIMETAL
ASSEMBLY FRAME

CREATION : 09/05/23
REVISION : 20/03/24

ASSEMBLY : **33-57-2510**
AUTHOR : D. CHASSÉ

#	PART#	QTY	TITLE
1	33-50-0010	1	DRAW BAR
2	33-04-0605	1	HITCH PLATE
3	NC01-17-0123	2	HEX. BOLT GR2 ZINC 3/8-16 X 3 1/4"
4	NC02-32-0012	2	LOCK WASHER ZINC 3/8"
5	NC02-07-0018	2	HEX. NUT ZINC 3/8-16
6	NC02-25-0011	8	WASHER SAE ZINC 17/32 ID
7	NC02-32-0014	4	LOCK WASHER ZINC 1/2"
8	NC02-07-0020	4	HEX. NUT ZINC 1/2-13
9	NC01-17-0259	4	HEX. BOLT GR2 ZINC 1/2-13 X 4"
10	NC01-17-0116	1	HEX. BOLT GR2 ZINC 3/8-16 X 1 1/2"
11	NC02-22-0010	4	WASHER 13/32" ID
12	55-41-0000	1	SAFETY CHAIN
13	NC01-96-0011	1	NYLON NUT 3/8-16
14	23-50-0045	1	HITCH HAND
15	NC13-80-0290	1	2" HITCH BALL COUPLER
16	NC02-25-0011	2	WASHER SAE ZINC 17/32 ID
17	NC01-93-0014	2	LOCK NUT ZINC 1/2-13
18	NC01-25-0257	2	HEX. BOLT GR5 ZINC 1/2-13 X 3 1/2"
19	23-09-0100	1	HITCH SPACER
20	NC02-22-0012	2	WASHER ZINC 1/2 BOLT = 9/16"Ø X 1 3/8" OD

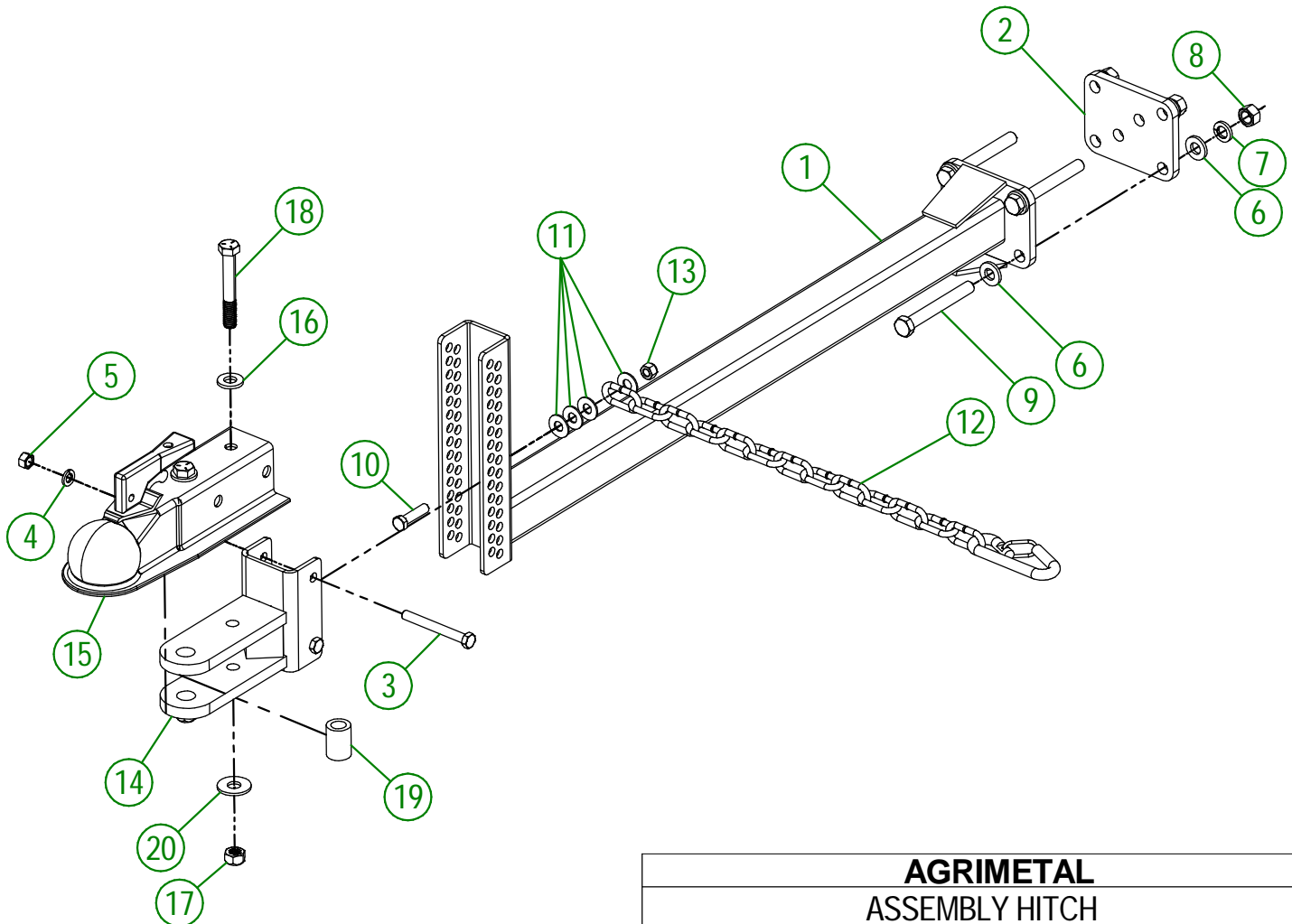

AGRIMETAL	
ASSEMBLY HITCH	
CREATION : 16/10/24	ASSEMBLY : 33-55-0040
REVISION : 29/04/25	AUTHOR : J.KABWE

33-57-2548

#	PART #	Qty	TITLE
1	01-01-2485	4	FLAT WASHER 14 GA X 13/16"OD X 25/64" ID
2	33-03-1005	4	ENGINE SHIM
3	33-22-5600	8	ENGINE STOPPER
4	NC01-07-0110	4	CARR. BOLT GR5 ZINC 3/8-16 X 1 1/4"
5	NC01-07-0113	4	CARR. BOLT GR5 ZINC 3/8-16 X 2" LG
6	NC02-07-0018	8	HEX. NUT ZINC 3/8-16
7	NC02-32-0012	8	LOCK WASHER ZINC 3/8"

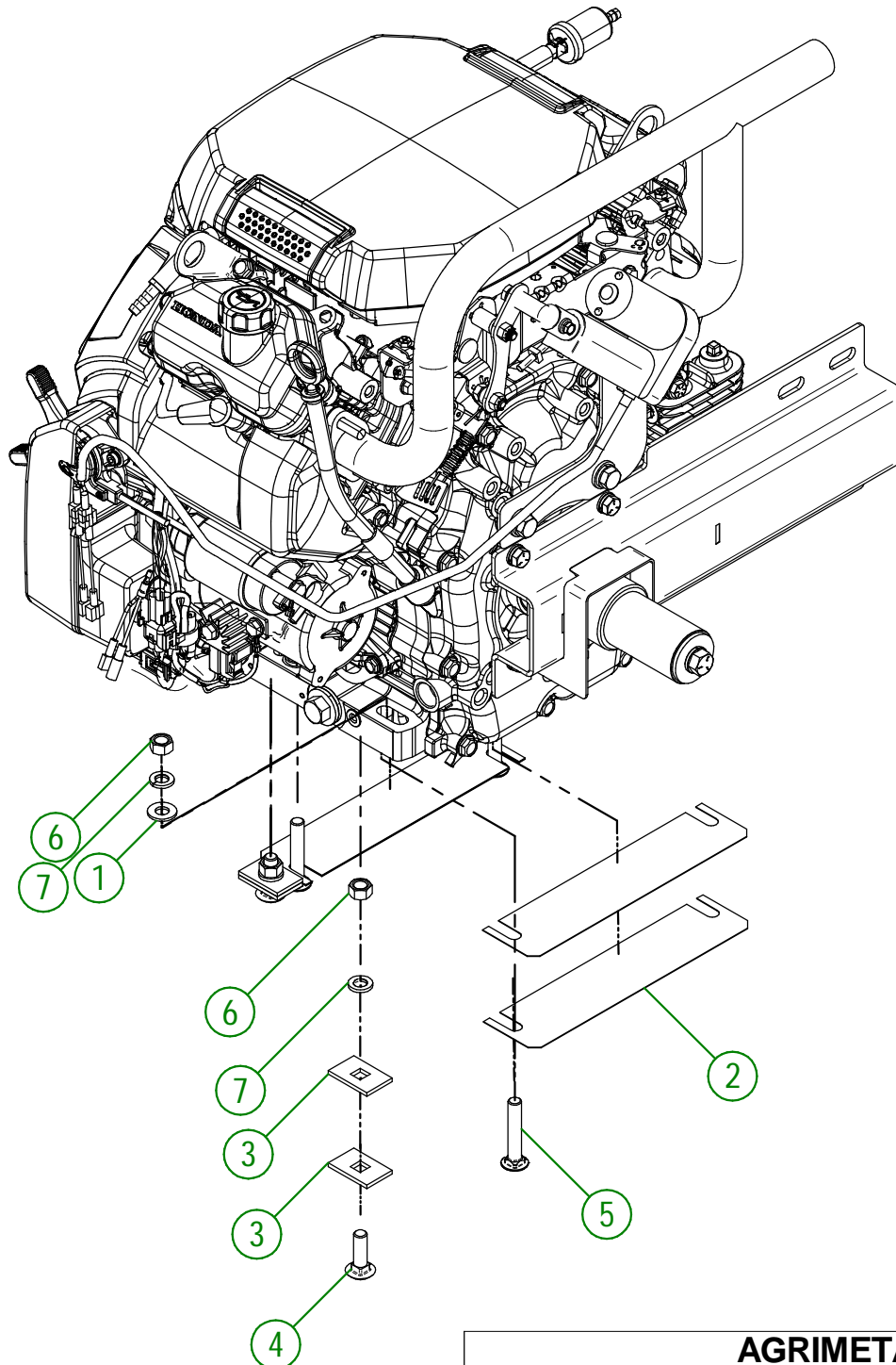

AGRIMETAL	
COMPLETE HONDA ENGINE WITH PARTS	
CREATION : 18/06/24	ASSEMBLY : 33-57-2548
REVISION : 18/06/24	AUTHOR : D. CHASSÉ

#	PART #	Qty	TITLE
1	33-04-1600	2	FLANGE
2	33-21-0055	4	SLEEVE
3	01-01-0925	4	WASHER
4	33-01-7570	2	WASHER
5	NC14-62-0016	1	QD BUSHING SH I 1/4"
6	NC14-62-0233	1	QD BUSHING SH I 5/8"
7	33-20-0152	2	SPACER
8	NC01-37-0253	4	HEX. BOLT GR8 ZINC 1/2-20 X 2 1/2"
9	NC01-94-0013	4	NYLON NUT ZINC 1/2-20"
10	33-41-0920	1	SQUARE KEY

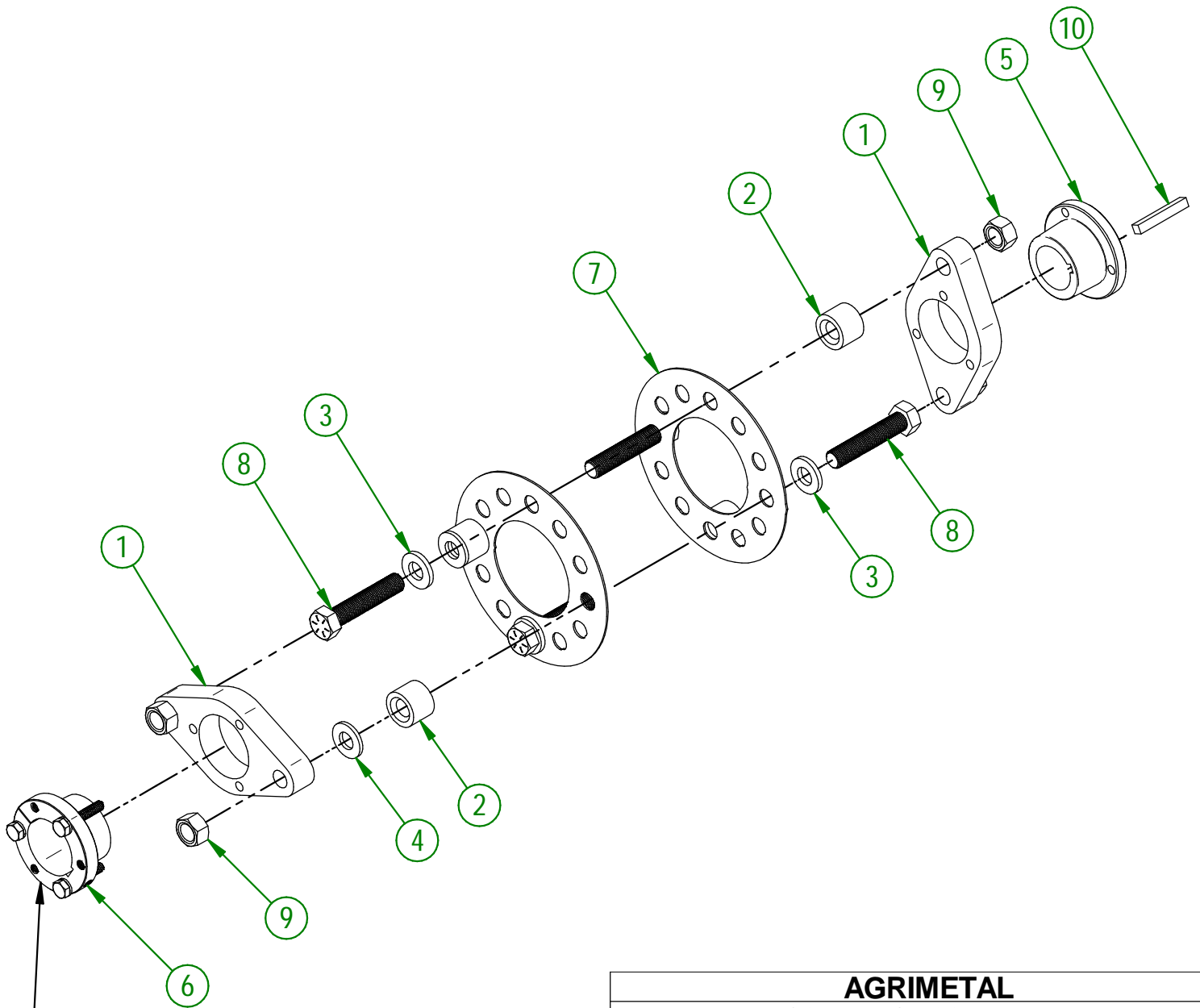

ENGINE SIDE

AGRIMETAL	
COUPLING ASSEMBLY	
CREATION : 20/09/22	ASSEMBLY : 33-57-0047
REVISION : 08/11/23	AUTHOR : D. CHASSÉ

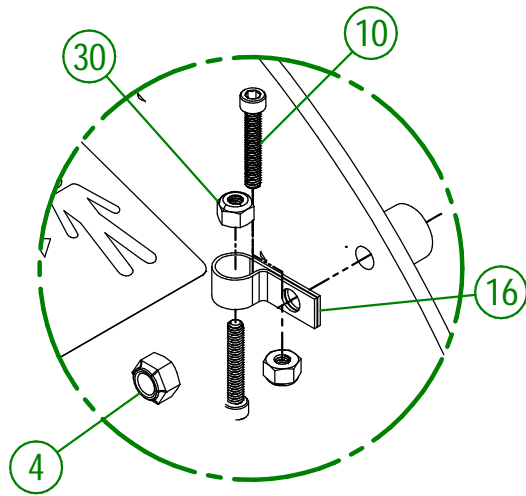
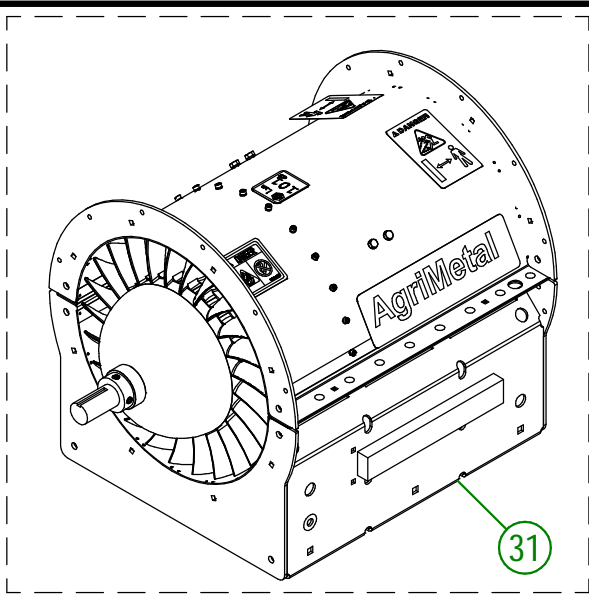

DETAIL A

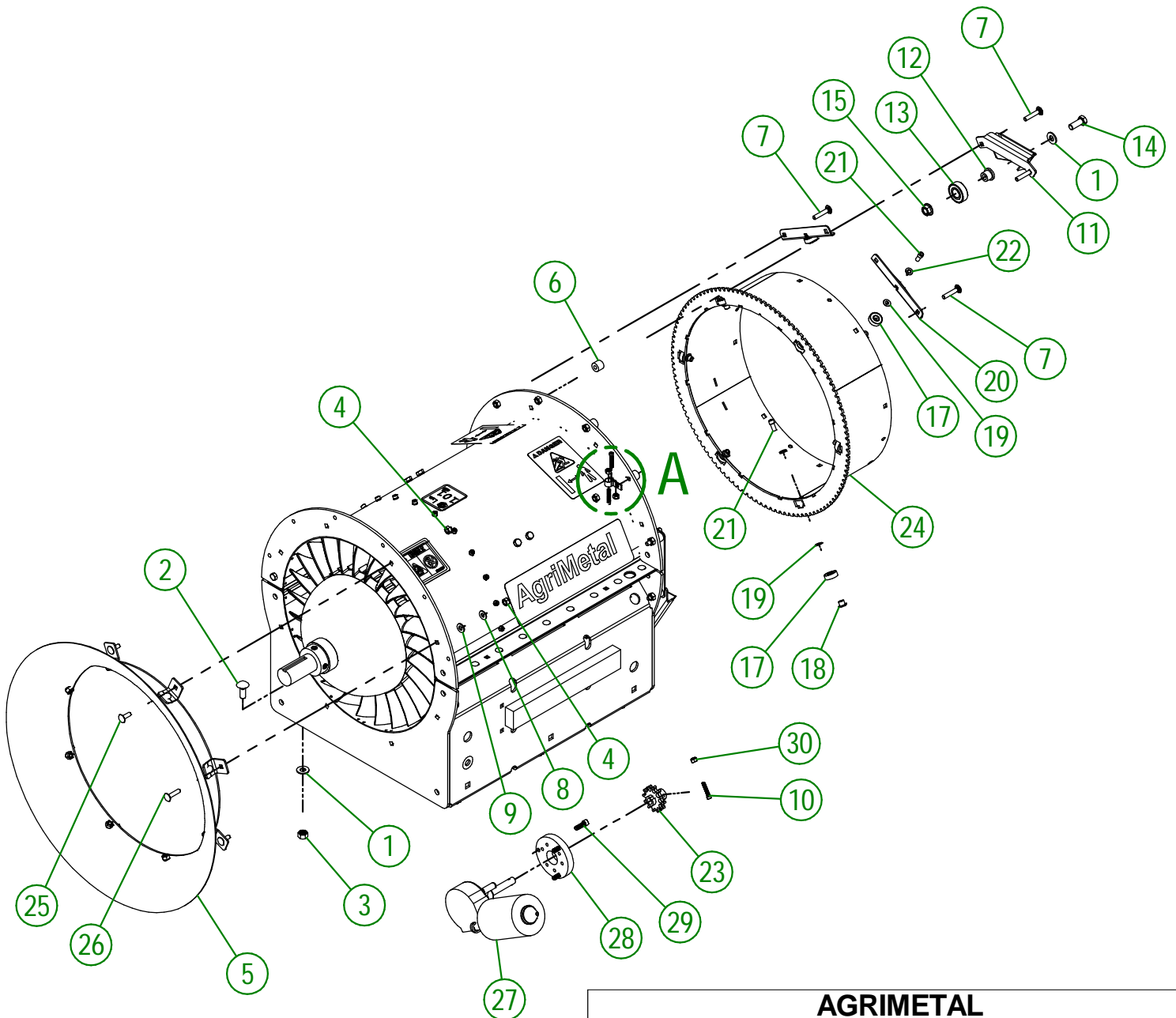

AGRIMETAL	
TURBINE	
CREATION : 21/06/24	ASSEMBLY : 33-57-0080
REVISION : 19/11/24	AUTHOR : D. CHASSÉ

33-57-0080

#	PART #	QTY	TITLE
1	NC02-25-0009	9	WASHER ZINC 0.406 = 13/32
2	NC01-04-0109	6	CARR. BOLT GR2 ZINC 3/8-16 X 1"
3	NC01-93-0011	6	LOCK NUT 3/8-16
4	NC01-96-0009	41	NYLON-INSERT LOCKNUT ZINC 1/4-20
5	33-55-0085	1	AIR INTAKE ASSY.
6	33-21-0080	12	SPACER
7	NC01-04-0006	12	CARR. BOLT GR2 ZINC 1/4-20 X 1 1/4"
8	NC02-25-0007	2	WASHER ZINC 0.281 = 9/32
9	NC02-22-0008	3	WASHER ZINC 5/16"
10	NC02-50-0069	3	SOCKET CAP SCREW T.RON 8-32 X 1"
11	33-50-0555	3	WELD ASSEMBLY BEARING SUPPORT
12	33-21-0060	3	BEARING HOLDER
13	NC14-75-0068	3	BALL BEARING 99502H
14	NC01-17-0114	3	HEX. BOLT GR2 ZINC 3/8-16 X 1"
15	NC02-14-0019	3	FLANGE NUT HEX. NC 3/8-16 GR. B
16	NC13-25-0233	1	VINYLE PROTECTOR COLLAR
17	NC14-75-0153	12	BALL BEARING R6 2RS 3/8" X 7/8" X 0.281"
18	33-25-2410	12	BEARING BUSHING
19	33-03-4605	12	BEARING SHIM 1/4" ALUMINUM
20	33-01-2425	6	BEARING HOLDER BRACKET
21	NC02-51-0578	12	SOCKET CAP SCREW T.RON. NF 1/4-28 X 1/2 STAINLESS
22	NC02-32-0010	12	LOCK WASHER ZINC 1/4"
23	33-50-2002	1	CROWN PINION
24	33-50-0018	1	DUCT COLECTOR
25	NC01-04-0003	6	CARR. BOLT GR2 ZINC 1/4-20 X 3/4"
26	NC01-04-0005	2	CARR. BOLT GR2 ZINC 1/4-20 X 1"
27	33-35-0005	1	OUTLET MOTOR
28	33-21-0100	1	ENGINE CONVERSION PLATE
29	NC02-50-1072	3	SOCKET CAP SCREW M6 X 20mm
30	NC01-96-0004	4	8-32 JAM NUT
31	33-57-0020	1	REGROUP. ENSEMBLE DE TURBINE (NEUF)

#	PART #	Qty	TITLE
1	NCI3-12-0017	1	12 VOLTS GEL BATTERY
2	NCI3-80-0267	1	RED PROTECTOR FOR BATTERY POST
3	NCI3-80-0268	1	BLACK PROTECTOR FOR BATTERY POST
4	33-57-2401	1	BATTERY SUPPORT PLATE "INCL. STICKER"
5	NCI3-15-0354	3	RED RUBBER BASE MOUNT
6	26-03-4800	9	WASHER
7	21-01-0950	3	FLAT WASHER 10GA 1.005" DIA X 25/64"
8	NC01-25-0126	3	HEX. BOLT GR5 ZINC 3/8-16 X 4"
9	NC02-25-0009	3	WASHER 0.406" I.D. X 0.815 O.D.
10	NC02-32-0012	3	LOCK WASHER ZINC 3/8"
11	NC02-07-0018	3	HEX. NUT ZINC 3/8-16
12	33-42-0130	2	BLACK ADHESIVE-BACK STRIP
13	NCI3-15-0008	1	RUBBER STRAP
14	33-42-0135	2	BLACK ADHESIVE-BACK STRIP

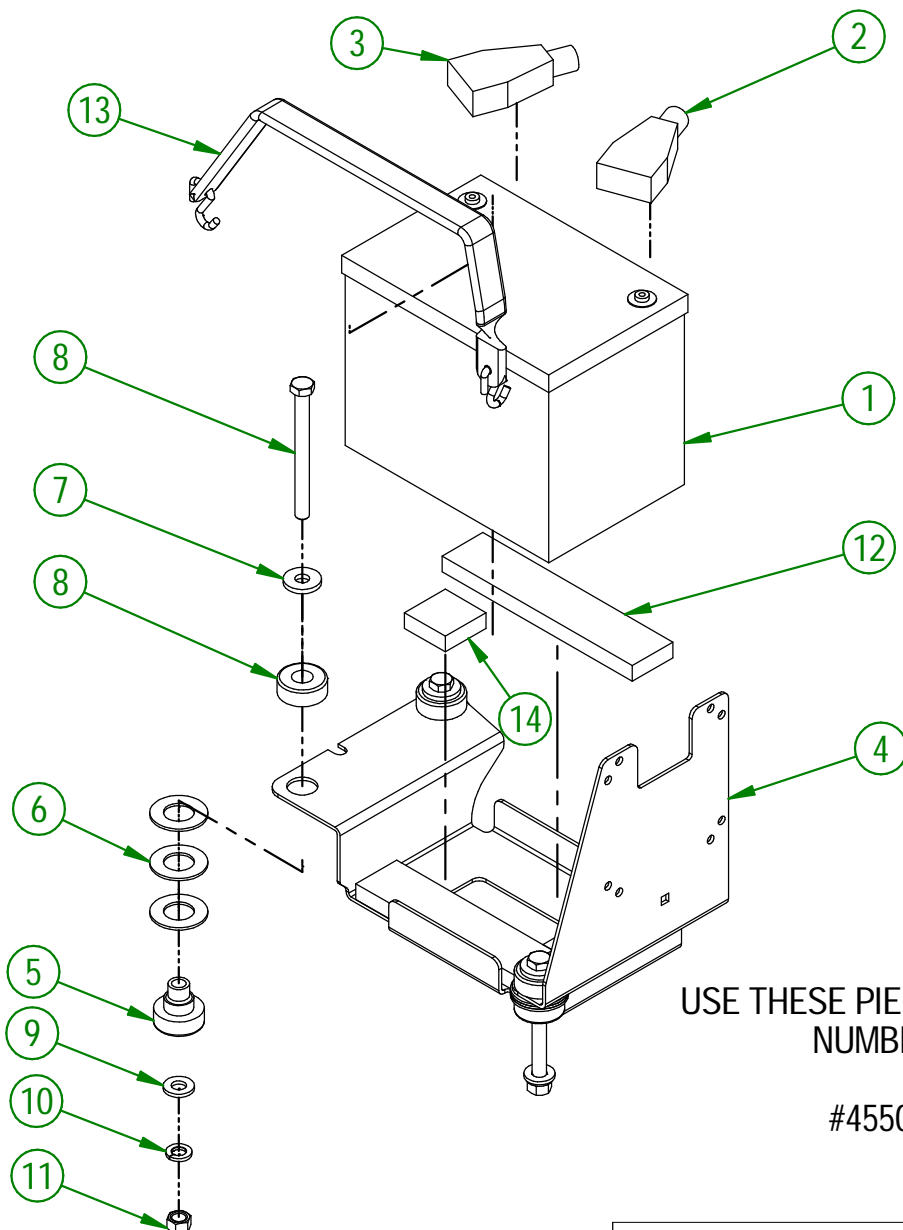

USE THESE PIECES ONLY IF YOUR SERIAL NUMBER IS AFFECTED:

#45503 AND ABOVE

AGRIMETAL	
12 VOLTS BATTERY GROUP.	
CREATION : 21/02/24	ASSEMBLY : 33-57-0059
REVISION : 30/05/25	AUTHOR : D. CHASSÉ

#	PART#	QTY	TITLE
1	NCI3-33-0052	2	STICKER FRAME LEVEL
2	NCI3-33-0183	1	STICKER CAUTION OPERATION MANUAL
3	NCI3-33-2675	2	STICKER TO INFLATE TIRE
4	NCI3-33-0227	1	STICKER FUSE 15 AMP MAXIMUM
5	NCI3-33-0192	2	STICKER (PROJECTION RISK)
6	NCI3-33-0185	1	STICKER PICTOGRAM (FIRE + CIGARETTE)
7	NCI3-33-0035	2	STICKER AGRIMETAL
8	NCI3-33-0129	1	STICKER 101 DB
9	NCI3-33-2674	2	STICKER TO PROGRAM REMOTE CONTROL
10	NCI3-33-0178	1	STICKER IMPORTANT PLEASE CHECK OIL LEVEL...

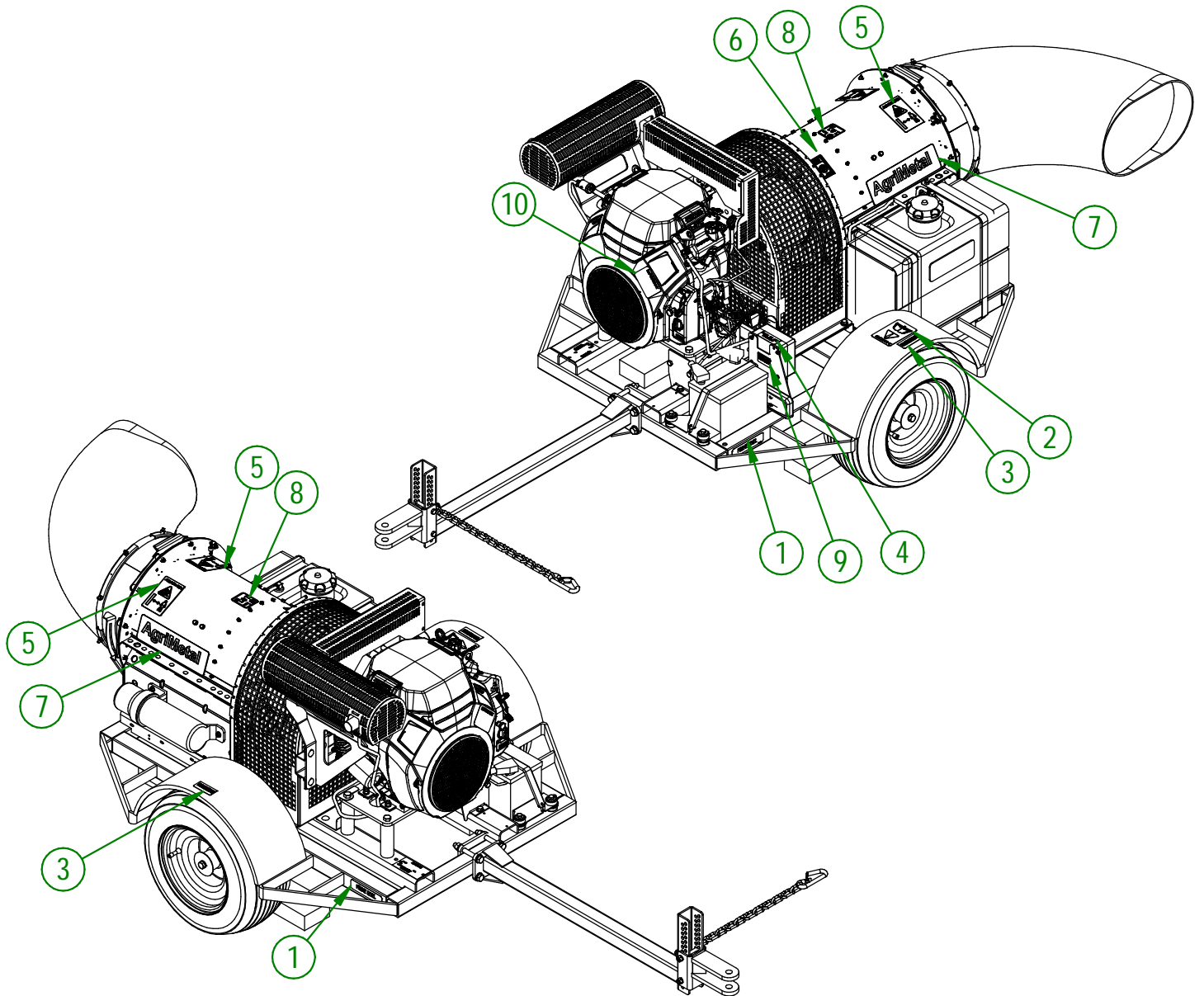
**AGRIMETAL****TURBINE BLOWER 240-B**

CREATION : 26/06/24
 REVISION : 26/06/24

ASSEMBLY : **33-99-3101**
 AUTHOR : D. CHASSÉ