

# AgriMetal

## PARTS LIST

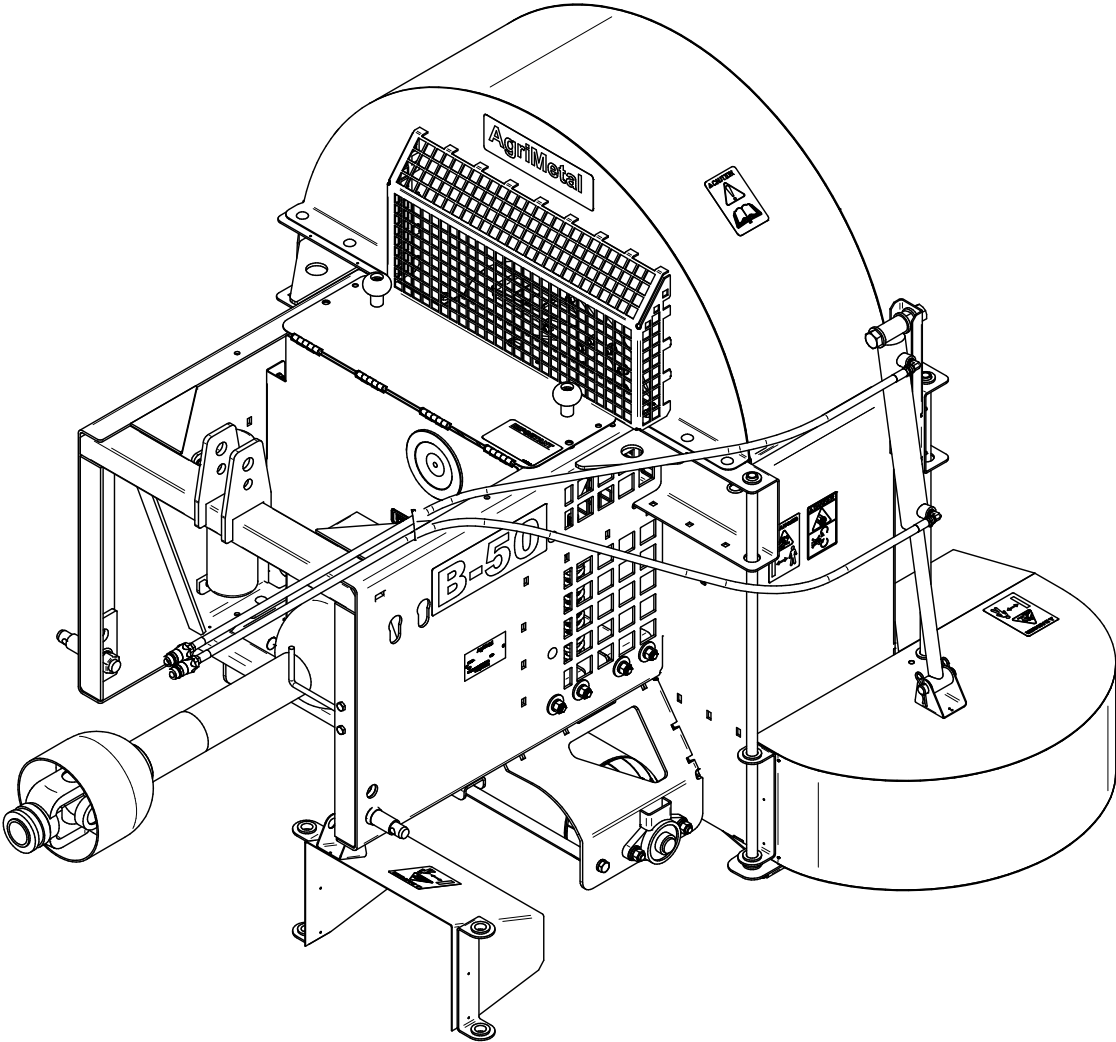

**B-50R**

32-57-8000

#	PART #	QTY	TITLE
1	NC17-46-0023	4	BUSHING 0.810" ID X 1.310" OD X 0.460"
2	NC01-78-0002	2	3 POINTS PIN 7/8-14 X 5 1/4"
3	09-04-0050	2	PNO 3/16" X 1 49/64" DIA. X Ø 7/8" FLAT WASHER
4	80-13-0105	2	BUSHING
5	32-50-7050	1	POWER TAKE-OFF BRACKET
6	NC01-17-0114	2	HEX. BOLT GR2 ZINC 3/8-16 X 1"
7	NC02-32-0012	2	LOCK WASHER ZINC 3/8"
8	NC02-07-0018	2	HEX. NUT ZINC 3/8-16

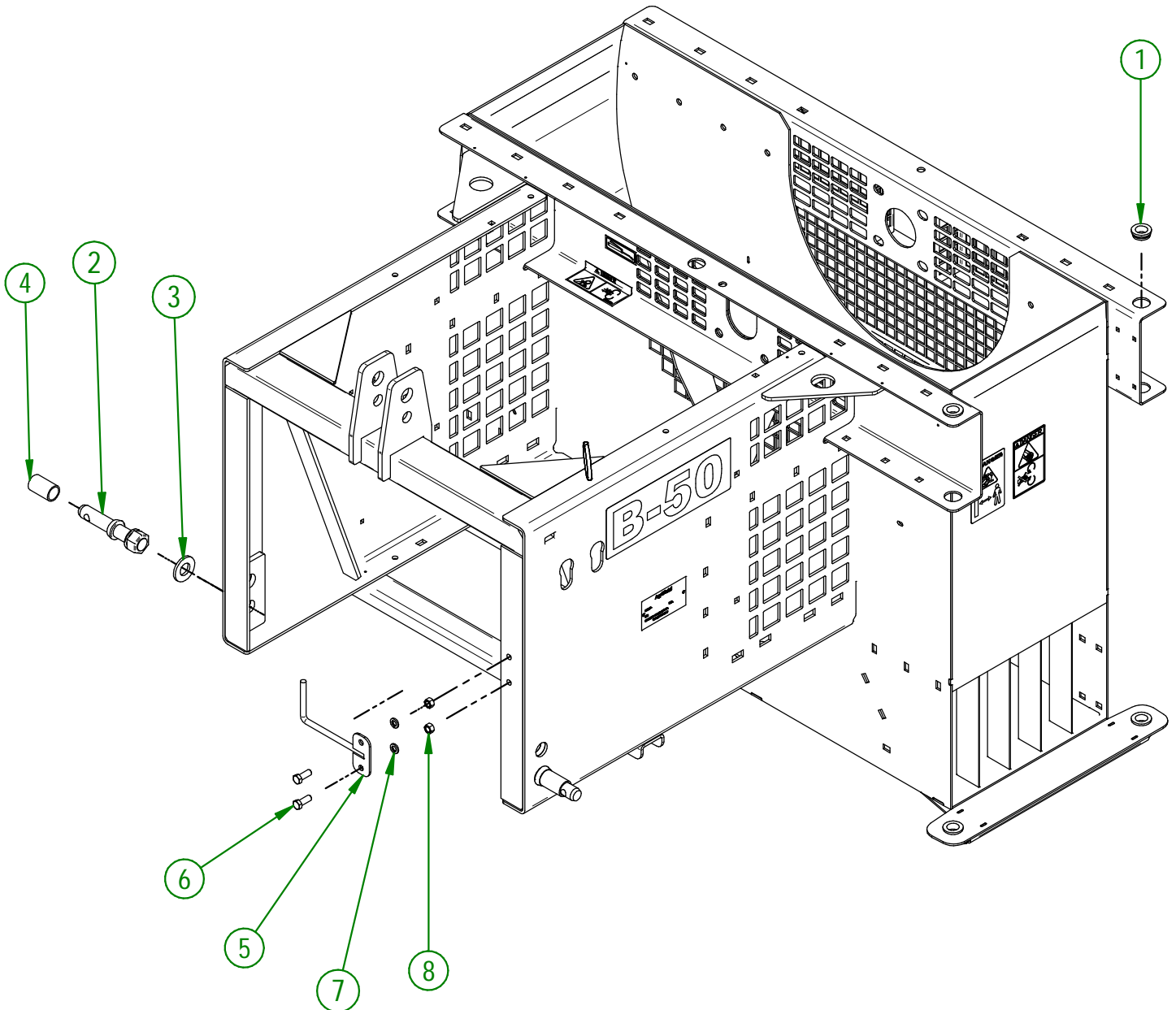

<b>AGRIMETAL</b>	
<b>ASSEMBLY B-50 FRAME</b>	
CREATION : 20/05/21	ASSEMBLY : <b>32-57-8000</b>
REVISION : 23/01/24	AUTHOR : G.HUBERDEAU

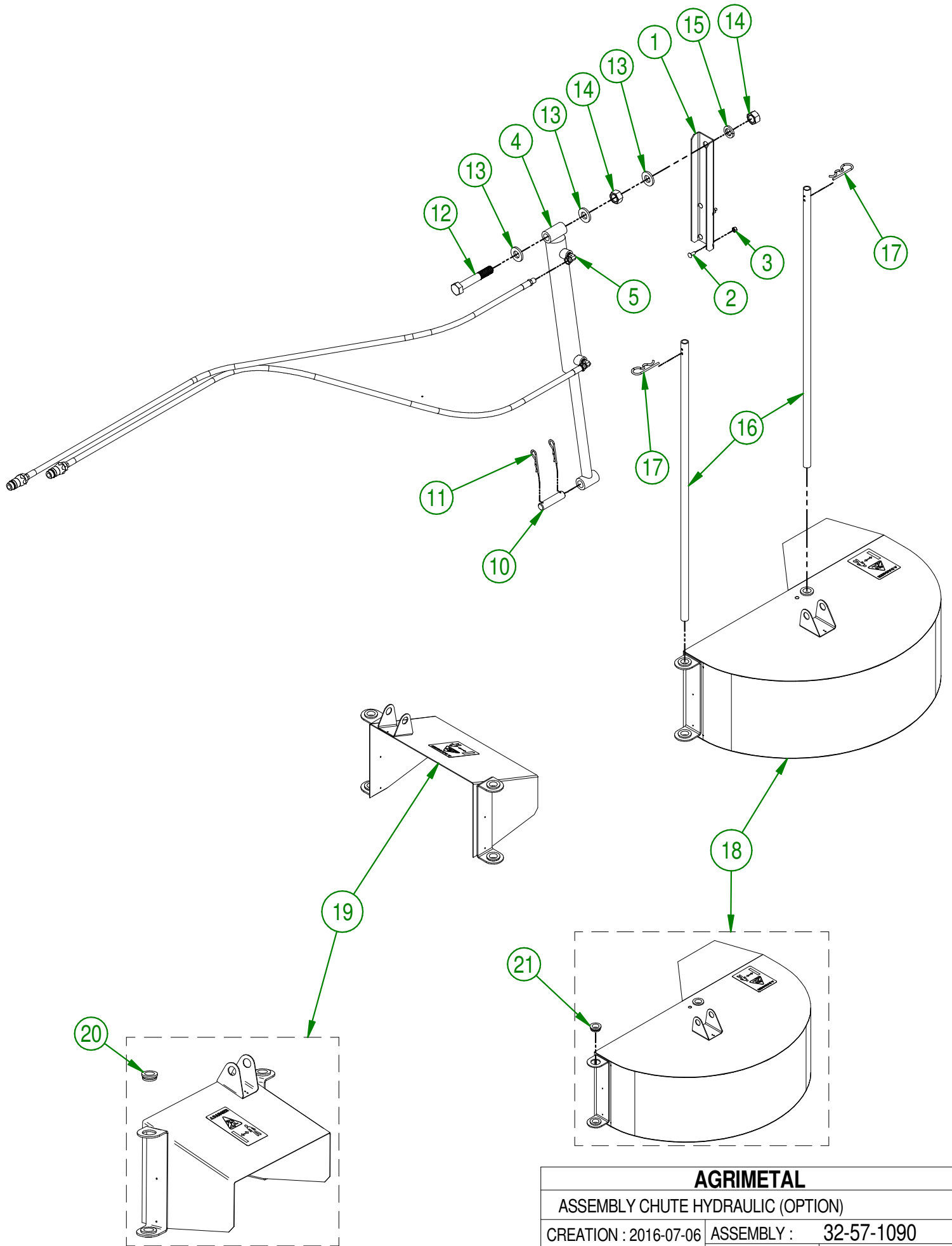

<b>AGRIMETAL</b>	
ASSEMBLY CHUTE HYDRAULIC (OPTION)	
CREATION : 2016-07-06	ASSEMBLY : 32-57-1090
REVISION : 2020-10-26	AUTHOR :

## 32-57-1090

#	PART #	QTY	TITLE
1	32-01-7550	1	CYLINDER BRACKET
2	NC01-04-0002	4	CARR. BOLT GR2 ZINC 1/4-20 X 5/8"
3	NC01-96-0009	4	NYLON-INSERT LOCKNUT ZINC 1/4-20
4	NC13-45-0148	1	HYDRAULIC CYL. 2" OD X 1" ROD X 18" OPEN X 10" TRAVEL
5	NC13-45-0026	2	90° Elbow - 7/16-20 MALE SAE 4 O-RINGS X 1/4 FEM.
6*	NC17-02-0319	1	HYD. PIPE BOYAU HYD. 1/4" X 84 " CUT 1/4 NPT MALE RIG. X 1/4 NPT MALE RIG.
7*	NC13-45-0014	2	QUICK COUPLER 1/2-14 NPTF
8*	NC13-45-0153	2	HEX. REDUCER 1/4 NPT X 1/2 NPT
9*	NC17-02-0319	1	HYD. PIPE BOYAU HYD. 1/4" X 84 " CUT 1/4 NPT MALE RIG. X 1/4 NPT MALE RIG.
10	32-21-0015	1	CYLINDER PIN
11	NC01-63-0015	2	COTTER PIN Z 1/8" X 2 5/8"
12	NC01-17-0478	1	BOLT HEX. GR2 ZINC 3/4-10 X 4 1/2"
13	22-04-6805	3	FLAT WASHER BEARING BASE
14	NC02-07-0023	2	HEX. NUT ZINC 3/4-10
15	NC02-32-0017	1	LOCK WASHER ZINC 3/4"
16	32-11-2500	2	CHUTE GUIDE
17	NC01-63-0026	2	COTTER PIN ZC 5/32" X 3"
18	32-55-1075	1	ASSEMBLY LARGE CHUTE
19	32-55-1080	1	ASSEMBLY SMALL CHUTE

## 32-55-1080

#	PART #	QTY	TITLE
20	NC17-46-0023	4	BUSHING 0.810" ID X 1.310" OD X 0.460"

## 32-55-1075

#	PART #	QTY	TITLE
21	NC17-46-0023	4	BUSHING 0.810" ID X 1.310" OD X 0.460"

**AGRIMETAL**

ASSEMBLY CHUTE HYDRAULIC (OPTION)

CREATION : 2016-07-06	ASSEMBLY :	32-57-1090
REVISION : 2020-10-26	AUTHOR :	

32-57-4300

#	PART #	Qty	TITLE
1	32-50-3050	1	WELD ASSEMBLY LARGE TURF ROLLER
2	32-38-0015	2	FLANGE BEARING UCFL206-18 X I 1/8" - GREASE FITTING 1/4-28"
3	32-12-0230	1	ROLLER SUPPORT REINFORCEMENT ROD
4	32-50-4300	1	RIGHT PRE-WELDING ROLLER HOLDER
5	32-50-4305	1	LEFT WELDING ROLLER SUPPORT
6	NCI3-80-0061	4	PAD STEEL POWDER 1/2" X 5/8" X 3/8"
7	NC01-04-0109	13	CARR. BOLT GR2 ZINC 3/8-16 X 1"
8	NC01-04-0235	4	CARR. BOLT GR2 ZINC 1/2-13 X I 1/2"
9	NC02-25-0011	4	WASHER SAE ZINC 17/32 ID
10	NC02-32-0014	6	LOCK WASHER ZINC 1/2"
11	NC02-07-0020	4	HEX. NUT ZINC 1/2-13
12	NC01-17-0249	2	HEX. BOLT GR2 ZINC 1/2-13 X I 1/2"
13	NC02-14-0019	13	FLANGE NUT HEX. NC 3/8-16 GR. B

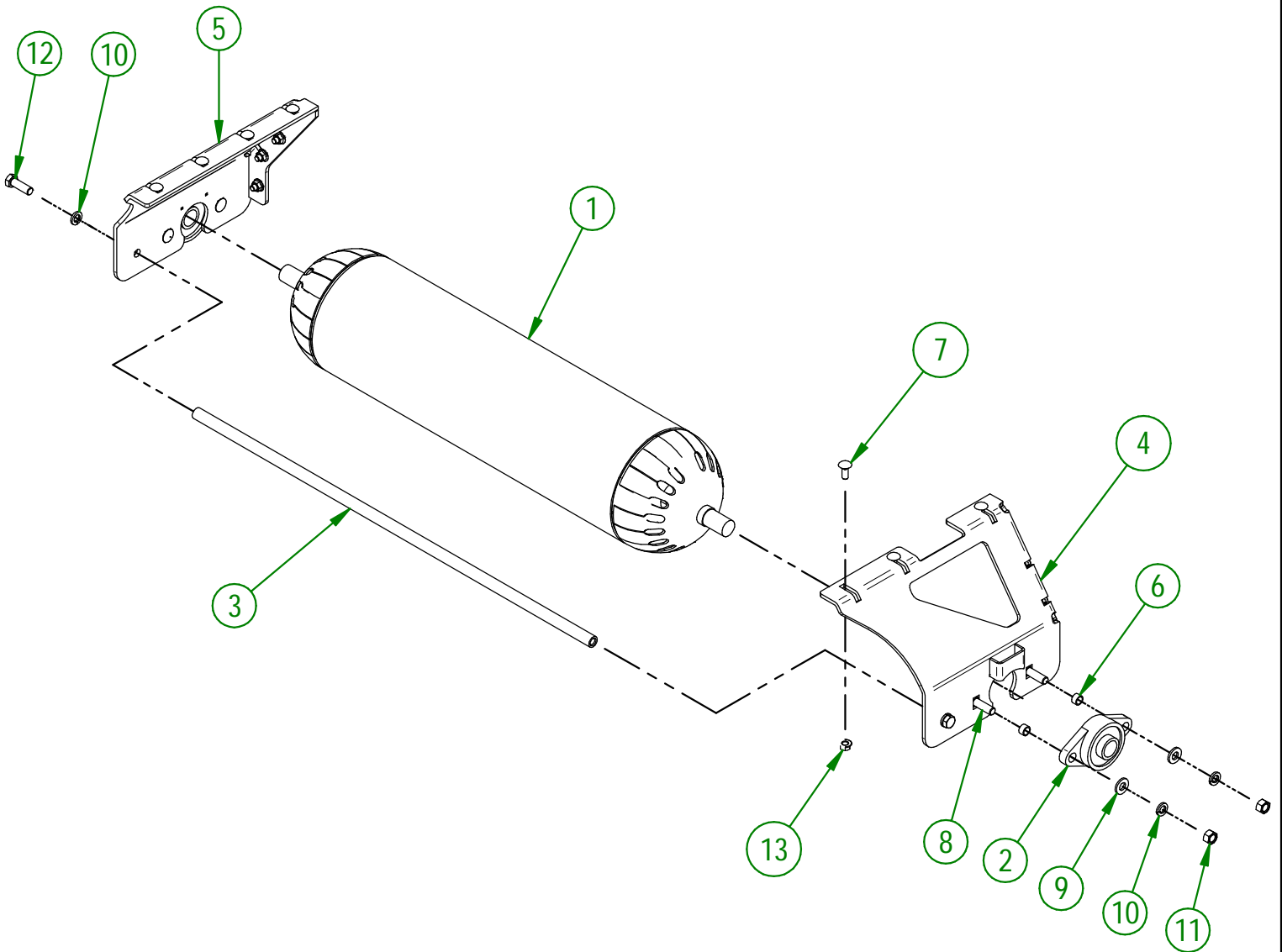

**AGRIMETAL**  
**ROLLER OPTION**

CREATION : 26/04/21  
 REVISION : 23/12/25

ASSEMBLY : **32-57-4300**  
 AUTHOR : J. Houle

32-57-1030

#	PART #	Qty	TITLE
1	32-55-1070	1	ASSEMBLY TURF ROLLER (REAR)
2	NC17-05-0034	1	LEFT SMALL TURF ROLLER SUPPORT
3	NC17-05-0033	1	RIGHT SMALL TURF ROLLER SUPPORT
4	NC01-04-0107	8	CARR. BOLT GR2 ZINC 3/8-16 X 3/4"
5	NC02-14-0019	8	FLANGE NUT HEX. NC 3/8-16 GR. B

32-55-1070

#	PART #	Qty	TITLE
6	32-11-3510	1	TURF ROLLER ONLY (REAR)
7	32-42-0105	2	REAR ROLL CAP

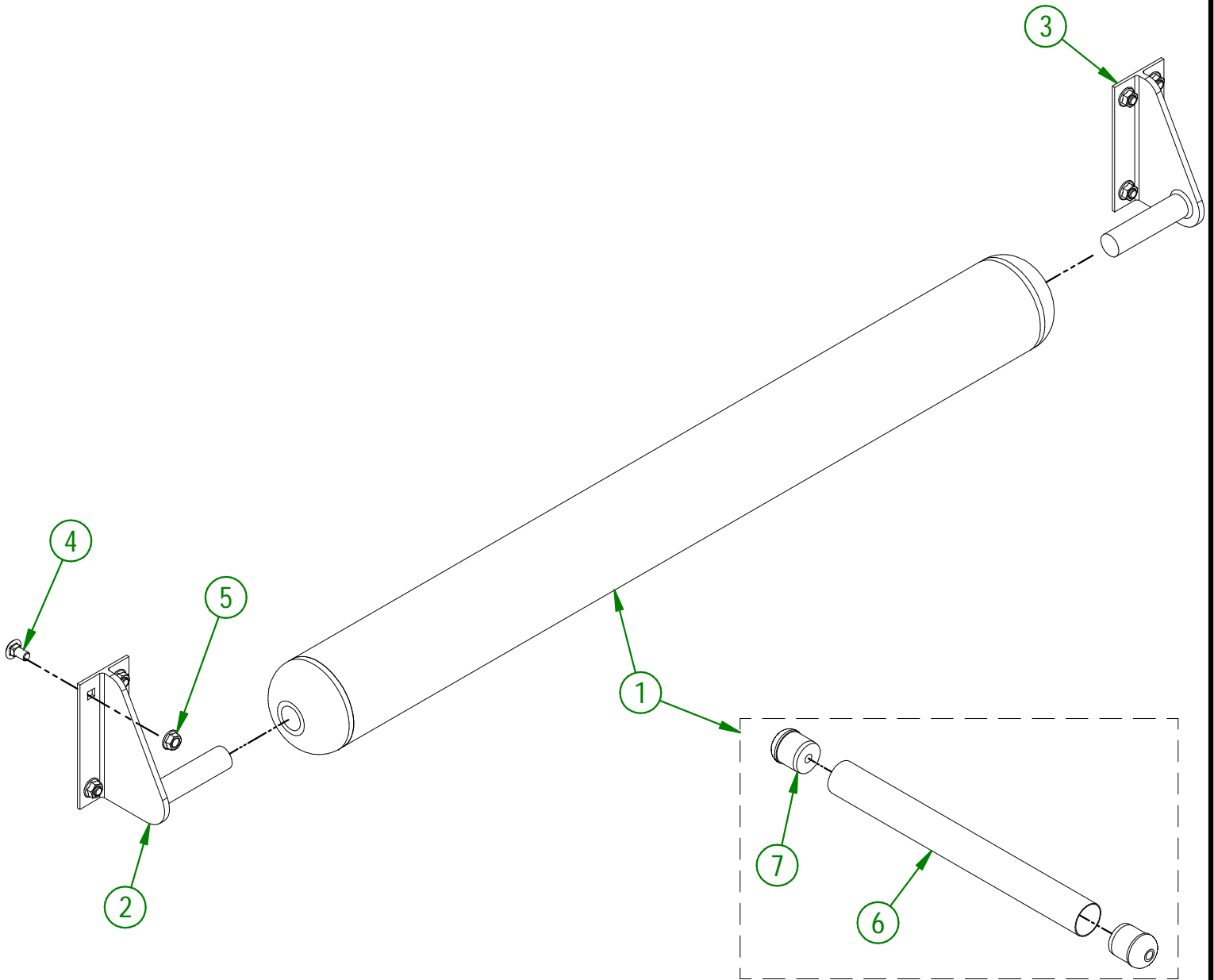

<b>AGRIMETAL</b>	
<b>ASSEMBLY TURF ROLLER GROUP.</b>	
CREATION : 2016-06-17	ASSEMBLY : 32-57-1030
REVISION : 2025-04-25	AUTHOR :

#	PART #	Qty	TITLE
1	NC01-04-0234	8	CARR. BOLT GR2 ZINC 1/2-13 X 1 1/4
2	01-01-1660	8	WASHER SPACER
3	NC02-32-0014	8	LOCK WASHER ZINC 1/2"
4	NC02-07-0020	8	HEX. NUT ZINC 1/2-13
5	32-04-0080	2	STOPPER BEARING BASE
6	32-57-1048	1	BEARING BASE ASSEMBLY
7	NC14-62-0013	1	QD BUSHING SF 1 3/4"
8	NC14-62-0230	1	PULLEY QD 5VI/2-5/8 X 13.95 DE X SF 5BI36
9	NC01-65-0100	1	KEY 3/8 X 3/8 X 1 3/4"
10	NC14-25-5370	1	V BELT 21/32 COGED RAW EDGE B-57
11	32-01-1395	4	BEARING WHASER Ø 3/4"
12	NC02-07-0022	4	HEX. NUT ZINC 5/8-11
13	NC14-75-0115	2	PILLOW BLOCK UCP209-28 Ø 1 3/4"
14	NC02-32-0016	4	LOCK WASHER ZINC 5/8"
15	NC01-04-0276	4	BOLT CARR. GR2 ZINC 5/8-11 X 4"
16	32-20-0062	1	DRIVE SHAFT
17	NC01-64-0026	5	RETAINING RING 1 3/4"
18	32-34-0030	1	PTO SHAFT

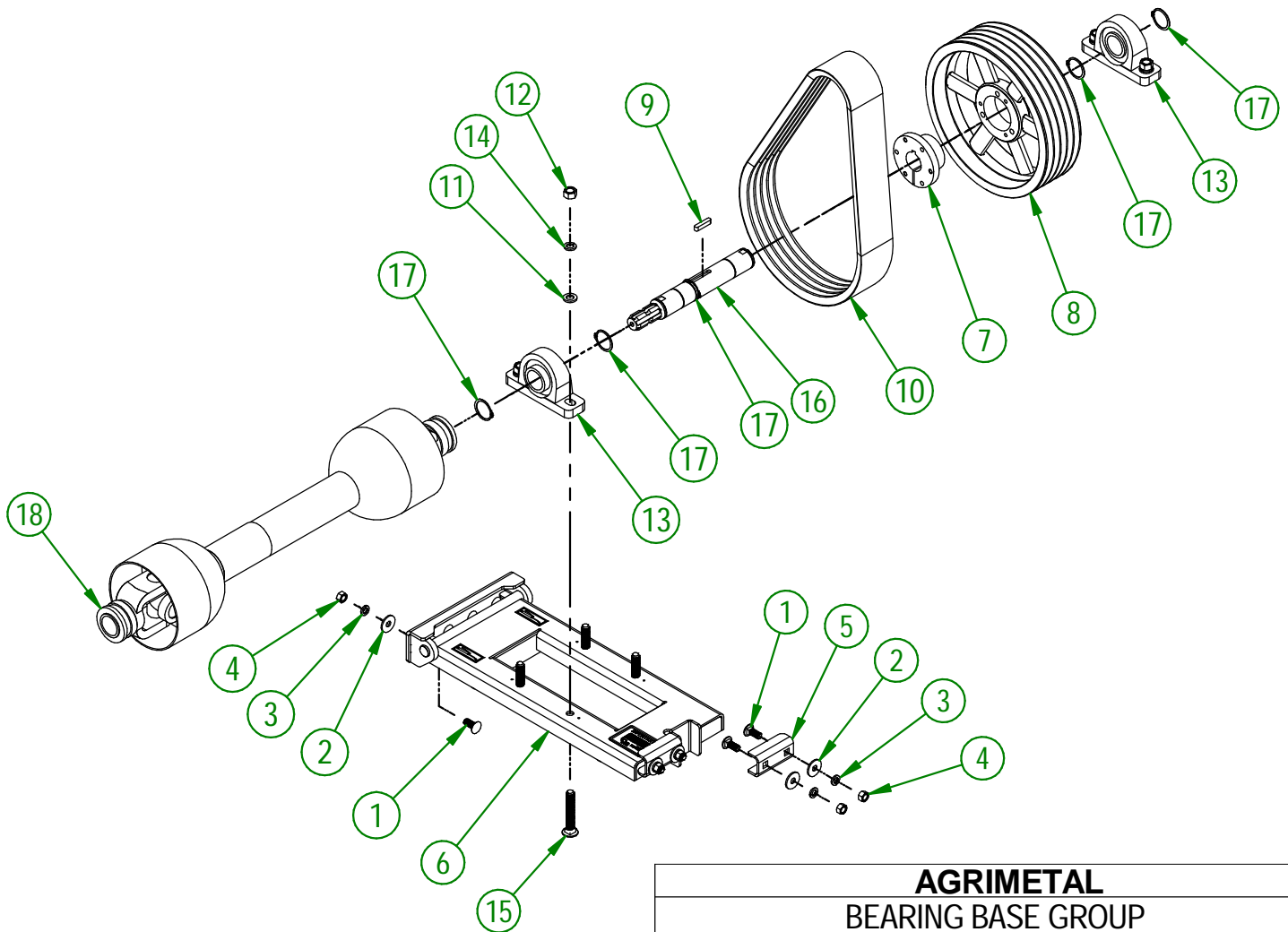

**AGRIMETAL**  
BEARING BASE GROUP

CREATION : 20/05/21  
REVISION : 27/09/22

ASSEMBLY : **32-57-8045**  
AUTHOR : G.HUBERDEAU

32-57-1086

#	PART #	Qty	TITLE
1	NC01-17-0119	2	HEX. BOLT GR2 ZINC 3/8-16 X 2 1/4"
2	01-01-2485	2	FLAT WASHER 14 GA X 13/16"OD X 25/64" ID
3	NC02-32-0012	2	LOCK WASHER ZINC 3/8"
4	NC02-07-0018	2	HEX. NUT ZINC 3/8-16
5	NC17-46-0018	2	HANDLE KNOB
6	32-57-1051	1	ASSEMBLY BELT GUARD
7	NC01-04-0055	2	CARR. BOLT GR2 ZINC 5/16-18 X 5/8"
8	NC01-96-0010	2	NYLON NUT HEX. ZINC 5/16-18
9	NC01-04-0109	4	CARR. BOLT GR2 ZINC 3/8-16 X 1"
10	NC02-14-0019	4	FLANGE NUT HEX. NC 3/8-16 GR. B

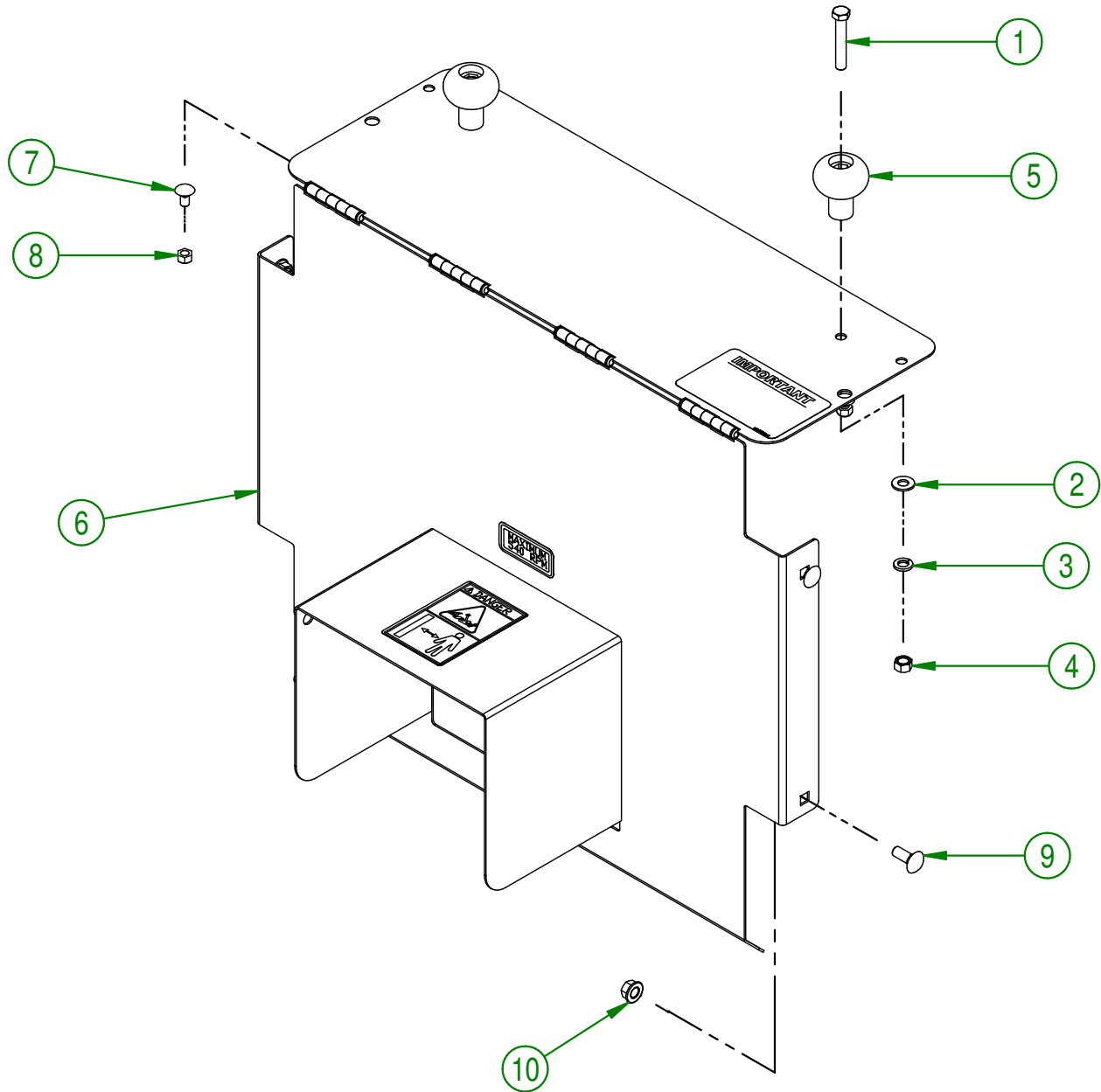

<b>AGRIMETAL</b>	
<b>ASSEMBLY BELT GUARD</b>	
CREATION : 26/04/21	ASSEMBLY : <b>32-57-1086</b>
REVISION : 26/04/21	AUTHOR : J. Houle

#	# DE PIÈCE	Qty	TITLE
1	32-50-1020	1	TENSIONER THREADED ROD
2	22-04-6805	1	FLAT WASHER BEARING BASE
3	NC02-07-0023	2	HEX. NUT ZINC 3/4-10
4	32-01-3070	1	HANDLE
5	32-42-0125	1	SPRING STOPPER
6	32-42-0100	1	SPRING GUIDE
7	12-44-0015	1	RED SPRING 1 1/2" OD 1" ID X 8 1/2"

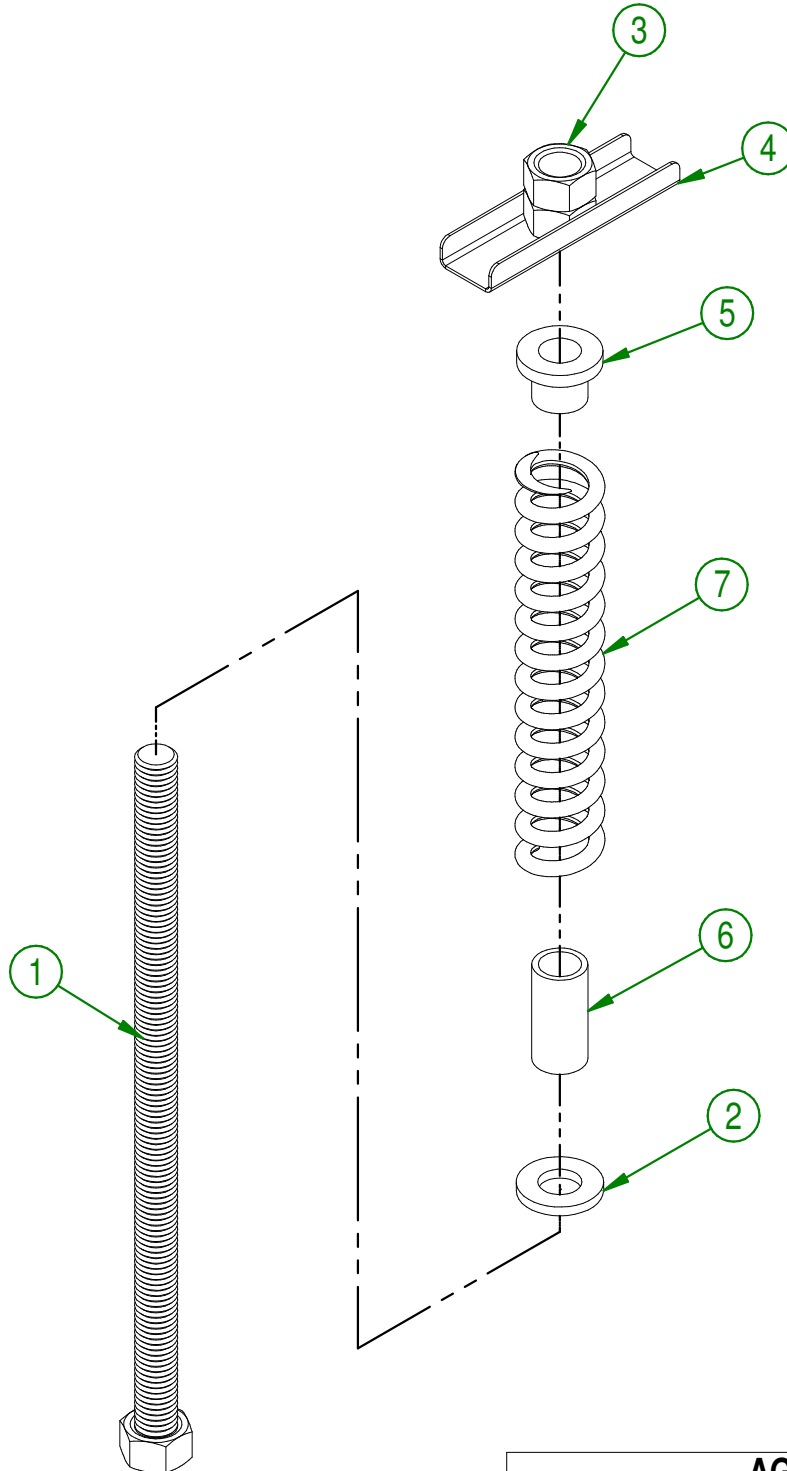

<b>AGRIMETAL</b>	
<b>ASSEMBLY BELT TENSIONER</b>	
CREATION : 2016-06-17	ASSEMBLY : 32-57-1035
REVISION : 2018-01-04	AUTHOR : S.B.

#	PART #	Qty	TITLE
1	32-57-7005	1	IMPELLER
2	NC14-75-0025	1	FLANGE BEARING 4 HOLES UCF 208-24 X 1 1/2"
3	NC14-75-0178	1	FLANGE BEARING 4 HOLES HCFU 209-28G X 1 3/4"
4	NC01-17-0396	8	HEX. BOLT GR2 ZINC 5/8-11 X 2"
5	NC02-22-0013	4	WASHER ZINC 5/8 ID X 1 1/2 OD
6	NC02-32-0016	8	LOCK WASHER ZINC 5/8"
7	NC02-07-0022	8	HEX. NUT ZINC 5/8-11
8	32-03-3610	1	REAR BEARING PROTECTOR
9	NC01-65-0307	1	KEY
10	NC14-62-0195	1	PULLEY QD 5V 1/2-5/8 X 5.35 DE X SD (5B50)
11	NC14-62-0008	1	QD BUSHING SD 1 3/4"

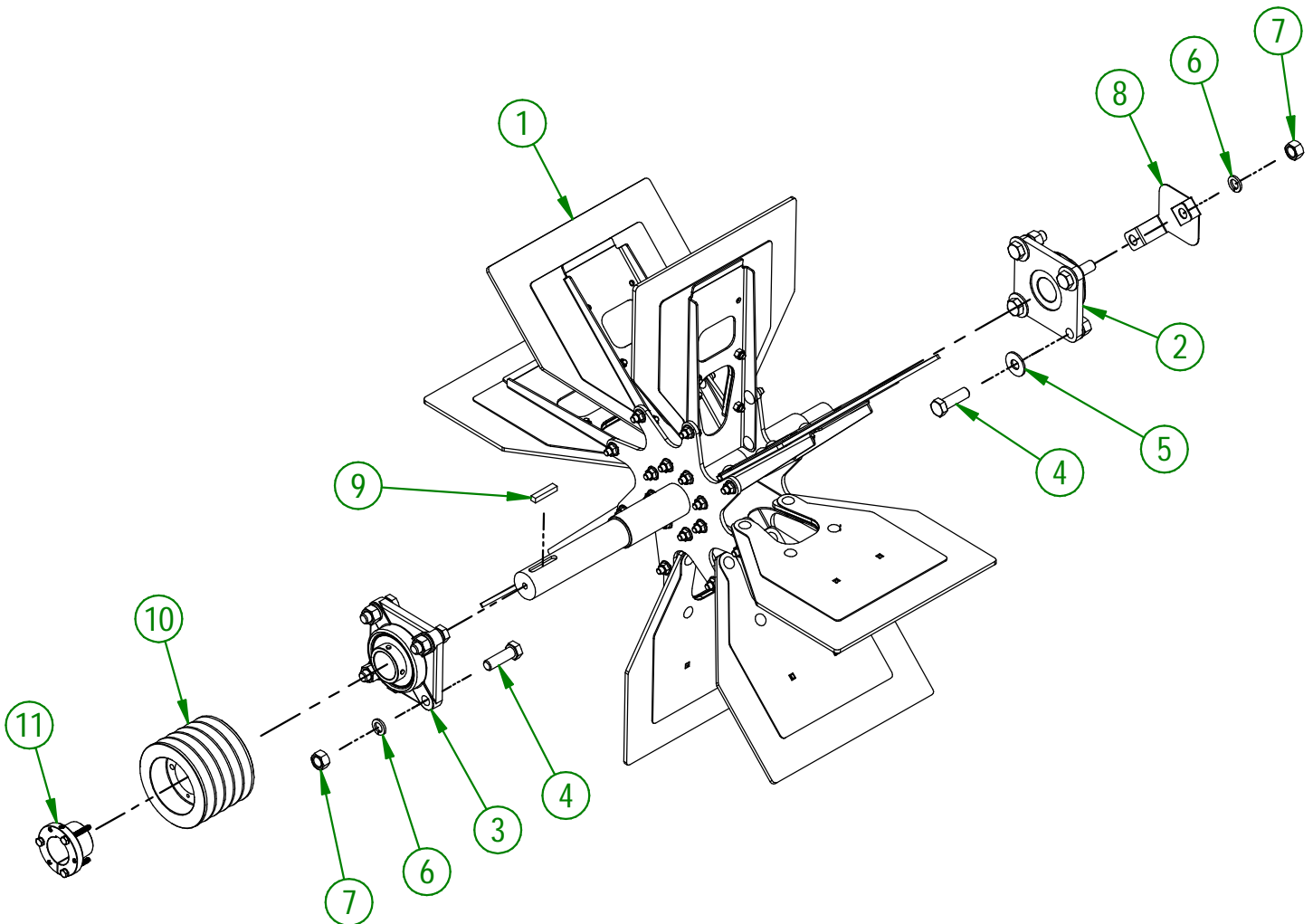

USE THESE PIECES ONLY IF YOUR SERIAL  
NUMBER IS AFFECTED:

#44706 ET UNDER

**AGRIMETAL**

ASSEMBLY DRIVE SHAFT PROPELLER

CREATION : 26/04/21  
REVISION : 30/10/24

ASSEMBLY : **32-57-1022**  
AUTHOR : J. Houle

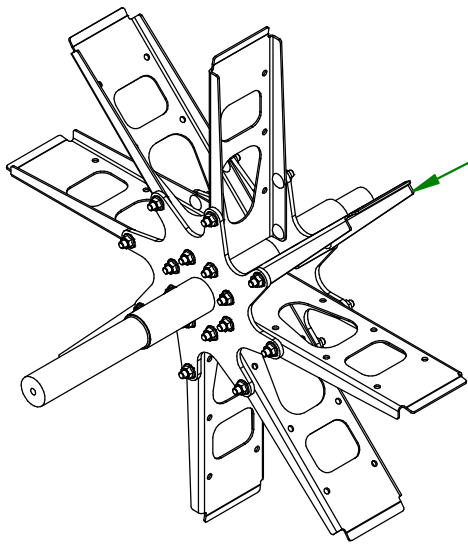

32-50-1070  
IMPELLER FRAME

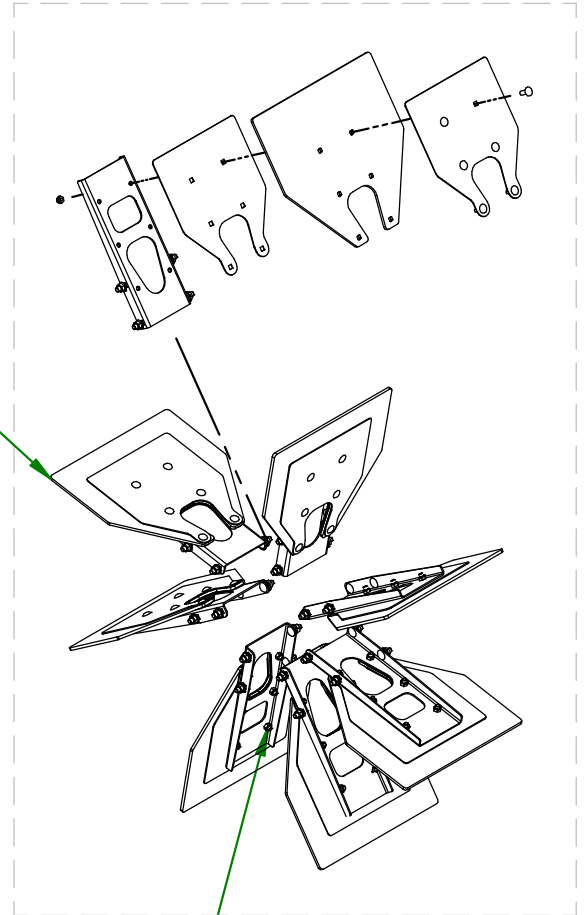

32-57-7010  
IMPELLER PADDLE AND PADDLE REINFORCEMENT GROUP

TORQUE AT  
120 INCH POUNDS

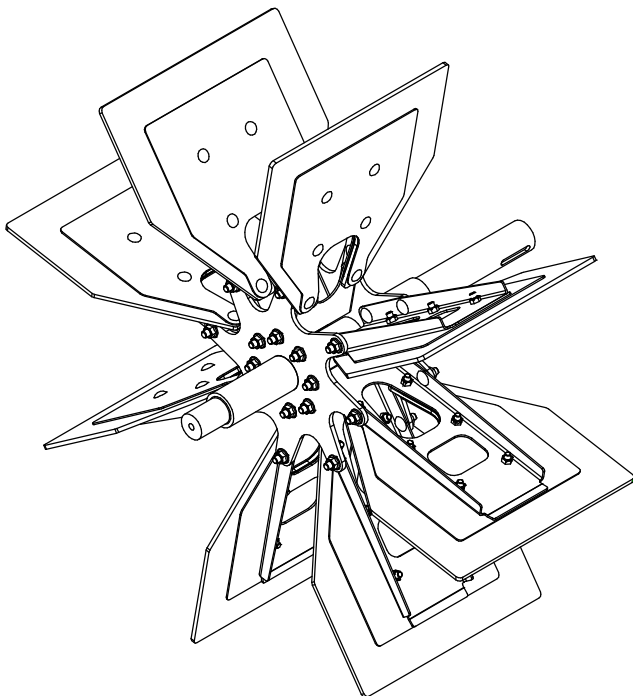

32-57-7005  
IMPELLER

USE THESE PIECES ONLY IF YOUR SERIAL  
NUMBER IS AFFECTED:

#44706 ET UNDER

**AGRIMETAL**  
IMPELLER

CREATION : 28/10/21  
REVISION : 02/10/23

ASSEMBLY : **32-57-7005**  
AUTHOR : J. Houle

#	PART #	Qty	TITLE
1	32-57-7006	1	IMPELLER
2	NC14-75-0025	1	FLANGE BEARING 4 HOLES UCF 208-24 X I 1/2"
3	NC14-75-0178	1	FLANGE BEARING 4 HOLES HCFU 209-28G X I 3/4"
4	NC01-17-0396	8	HEX. BOLT GR2 ZINC 5/8-11 X 2"
5	NC02-22-0013	4	WASHER ZINC 5/8 ID X I 1/2 OD
6	NC02-32-0016	8	LOCK WASHER ZINC 5/8"
7	NC02-07-0022	8	HEX. NUT ZINC 5/8-11
8	32-03-3610	1	REAR BEARING PROTECTOR
9	NC01-65-0307	1	KEY
10	NC14-62-0195	1	PULLEY QD 5V 1/2-5/8 X 5.35 DE X SD (5B50)
11	NC14-62-0008	1	QD BUSHING SD I 3/4"
12	32-09-0050	1	IMPELLER BUSHING

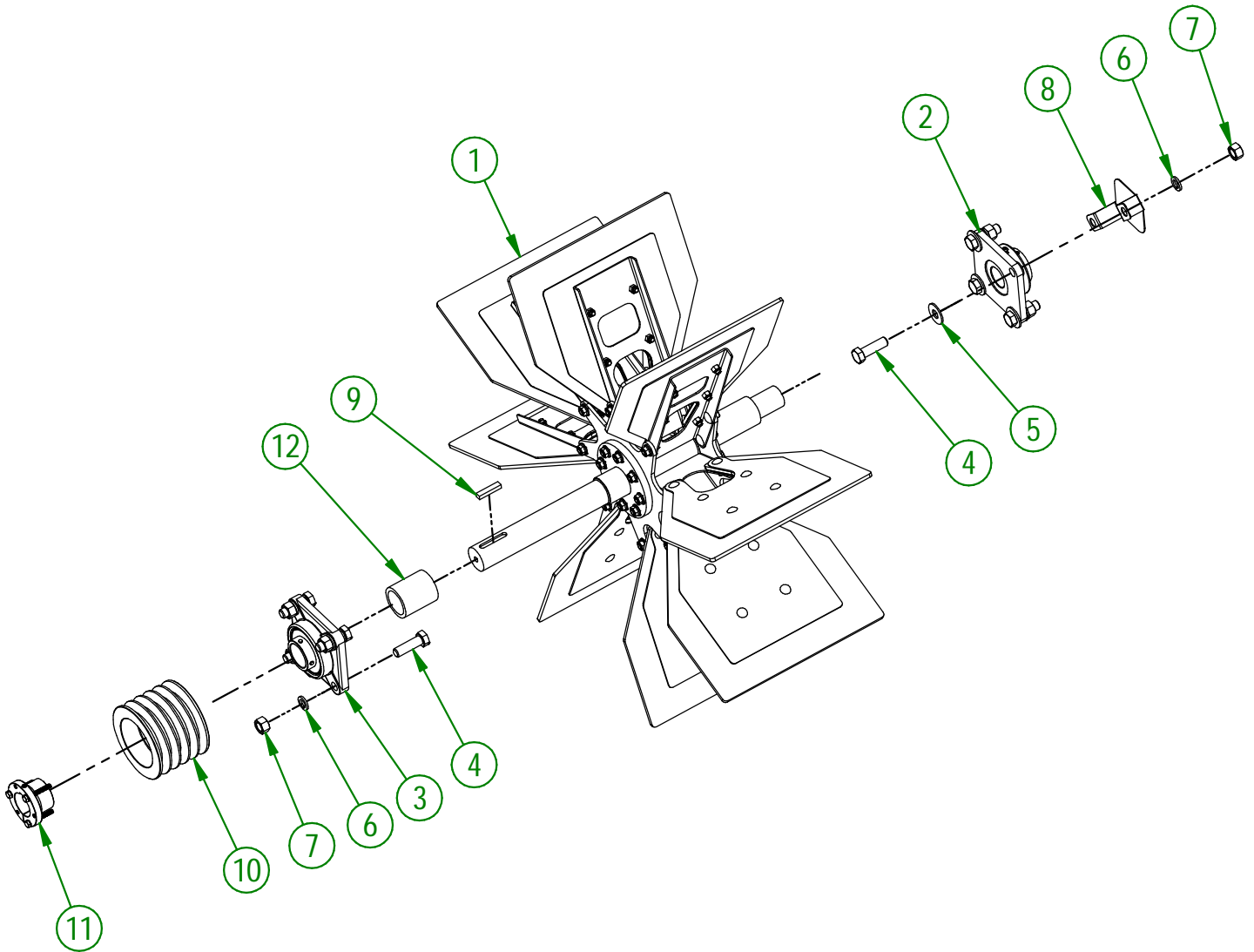

USE THESE PIECES ONLY IF YOUR SERIAL  
NUMBER IS AFFECTED:

BETWEEN #44707 AND 47112

**AGRIMETAL**

ASSEMBLY DRIVE SHAFT PROPELLER

CREATION : 02/10/23  
REVISION : 15/04/25

ASSEMBLY : **32-57-1023**  
AUTHOR : J. Houle

32-57-1024

#	PART #	QTY	TITLE
1	32-57-7006	1	IMPELLER
2	12-38-0030	1	FLANGE BEARING 4 HOLES UCF 208-24 X 1 1/2"
3	32-38-0020	2	FLANGE BEARING 4 HOLES HCFU 209-28G X 1 3/4"
4	NC01-25-0400	4	HEX. BOLT GR2 ZINC 5/8-11 X 3"
5	NC02-32-0016	8	LOCK WASHER ZINC 5/8"
6	NC02-07-0022	8	HEX. NUT ZINC 5/8-11
7	NC01-25-0395	4	HEX. BOLT GR5 ZINC 5/8-11 X 1 3/4" LG
8	32-03-3610	1	REAR BEARING PROTECTOR
9	NC01-65-0307	1	KEY
10	NC14-62-0195	1	PULLEY QD 5V 1/2-5/8 X 5.35 DE X SD (5B50)
11	NC14-62-0008	1	QD BUSHING SD 1 3/4"
12	32-04-0525	1	IMPELLER BEARING PLATE

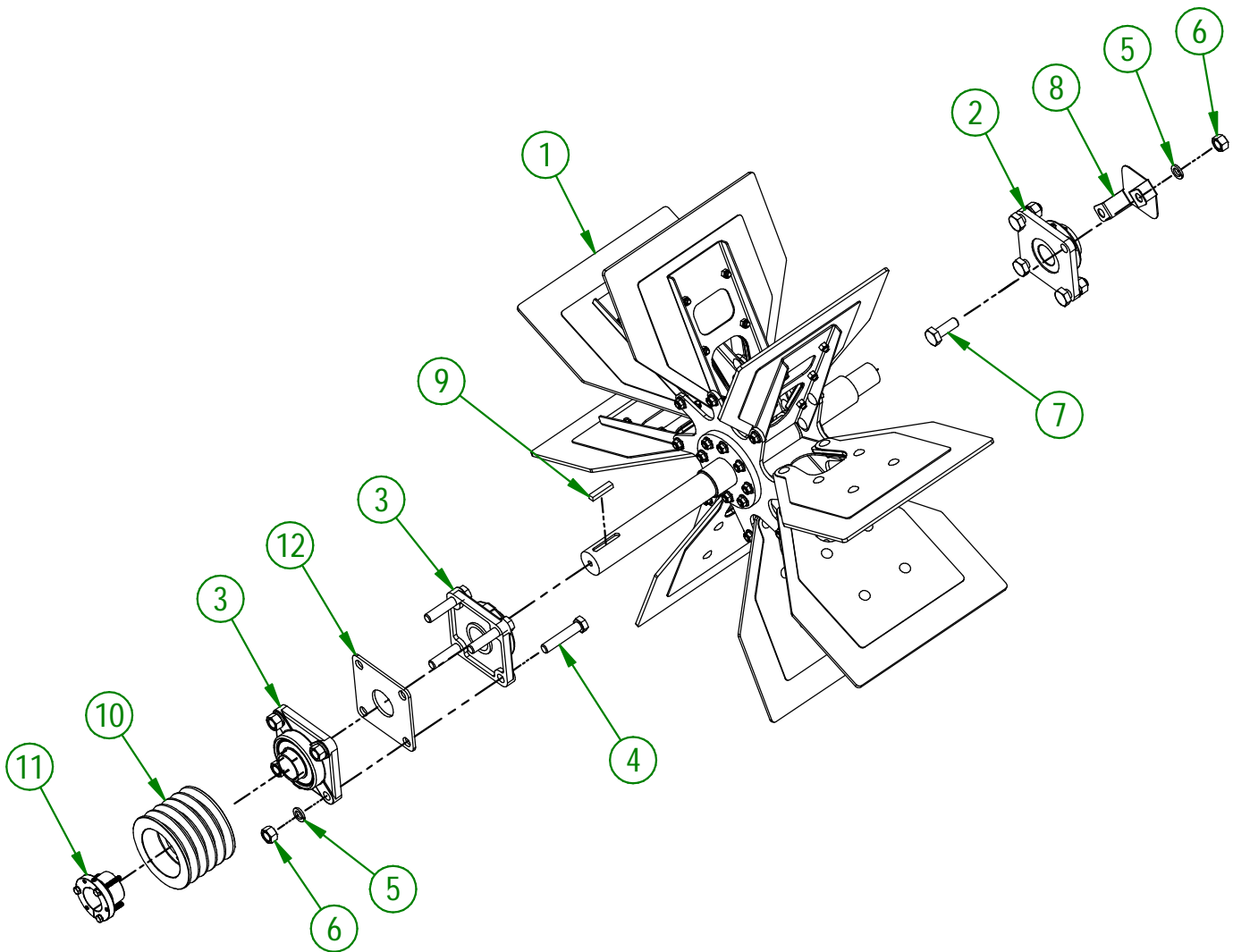

USE THESE PIECES ONLY IF YOUR SERIAL NUMBER IS AFFECTED:

#47113 AND ABOVE

<b>AGRIMETAL</b>	
<b>ASSEMBLY DRIVE SHAFT PROPELLER</b>	
CREATION : 16/04/25	ASSEMBLY : <b>32-57-1024</b>
REVISION : 05/01/26	AUTHOR : J. Houle

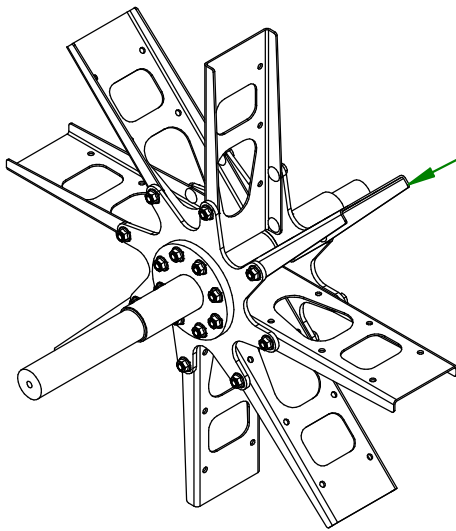

32-50-1071  
IMPELLER FRAME

32-57-7011  
IMPELLER PADDLE AND PADDLE  
REINFORCEMENT GROUP

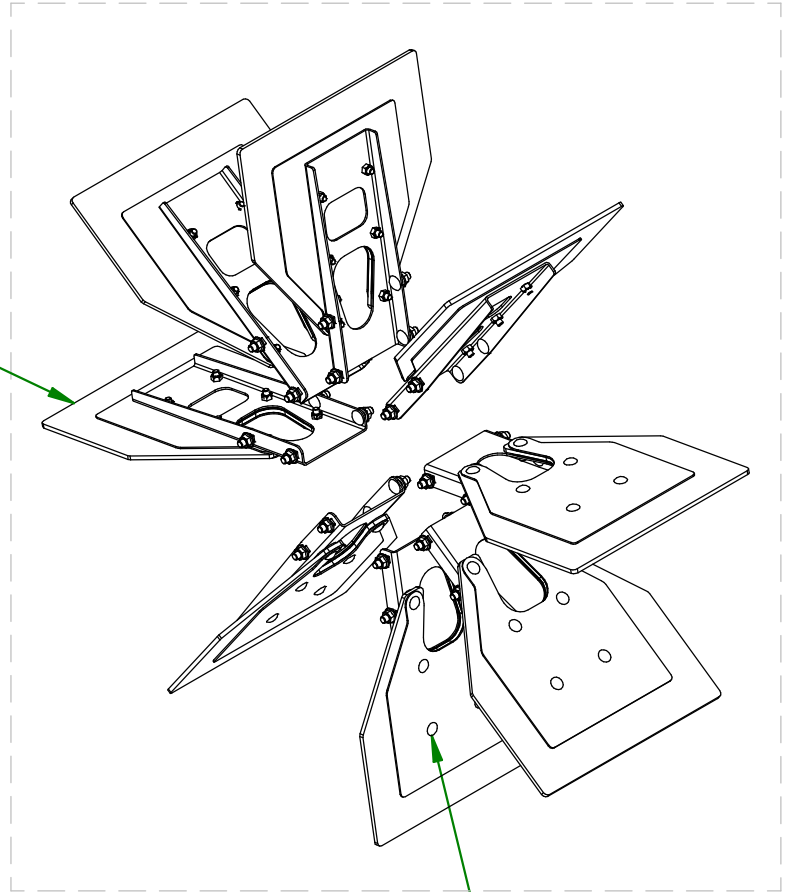

TORQUE AT  
120 INCH POUNDS

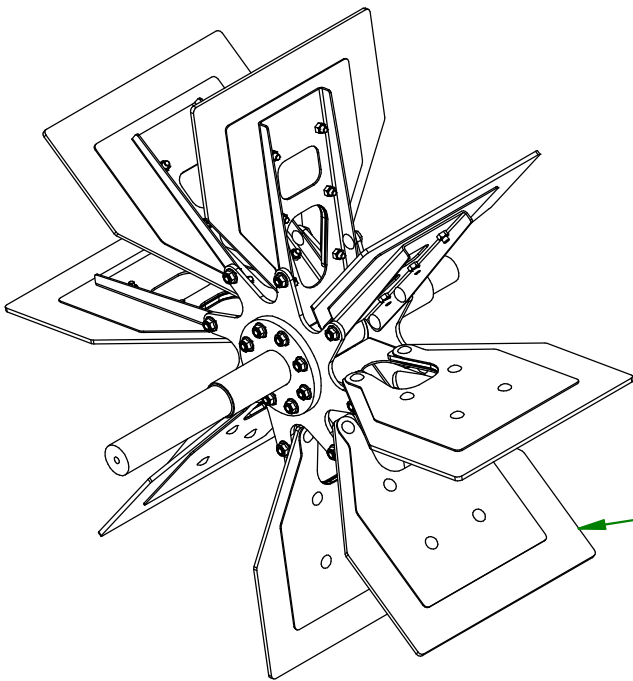

32-57-7006  
IMPELLER

USE THESE PIECES ONLY IF YOUR SERIAL  
NUMBER IS AFFECTED:

#44707 AND ABOVE

**AGRIMETAL**  
**PROPULSEUR**

CREATION : 02/10/23  
REVISION : 02/10/23

ASSEMBLY : **32-57-7006**  
AUTHOR : J. Houle

32-57-1041

#	PART #	Qty	TITLE
1	NC01-04-0107	10	CARR. BOLT GR2 ZINC 3/8-16 X 3/4"
2	NC02-14-0019	14	FLANGE NUT HEX. NC 3/8-16 GR. B
3	32-57-1006	1	ASSEMBLY CASING COVER

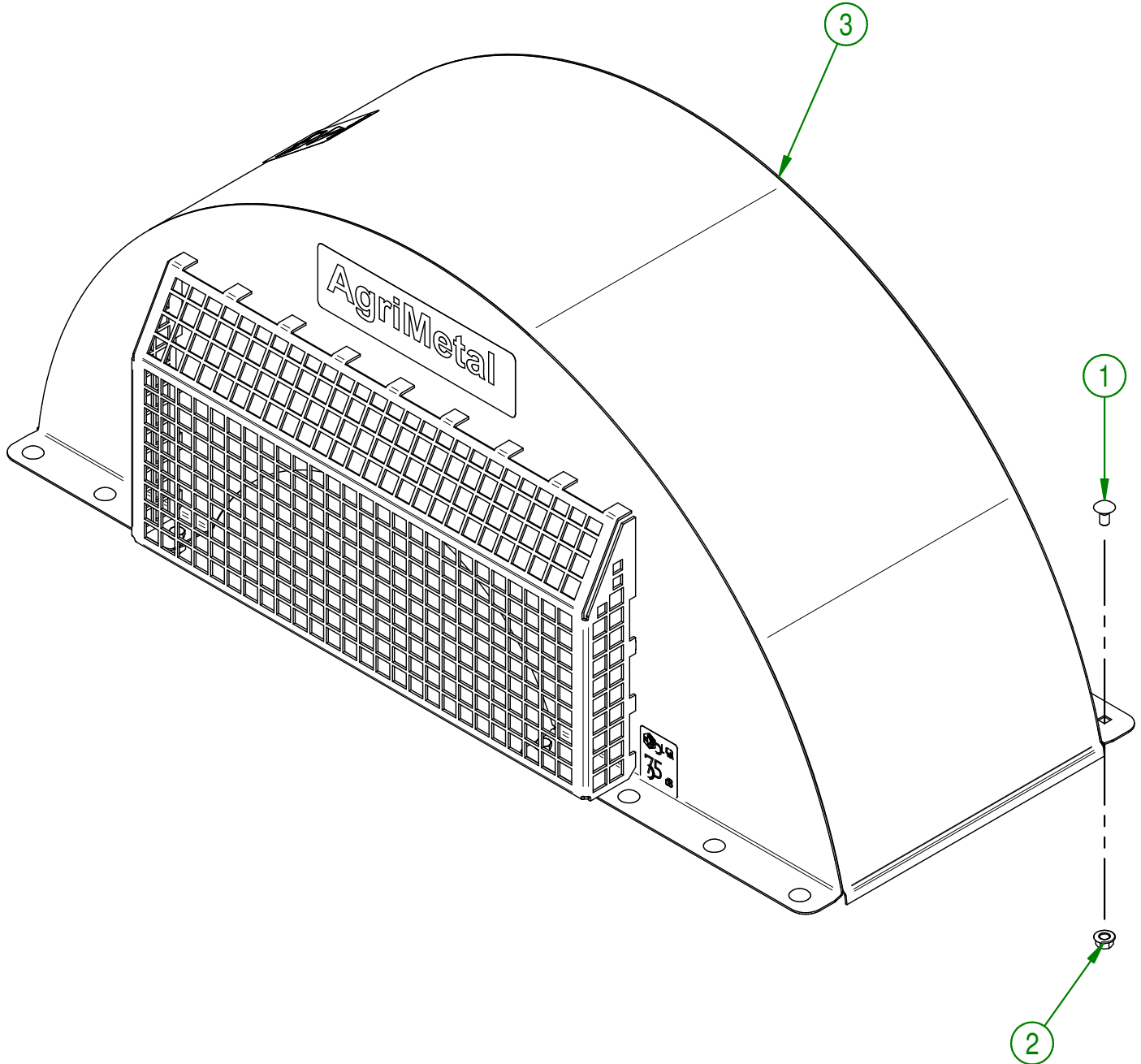

<b>AGRIMETAL</b>	
<b>ASSEMBLY COVER CASING</b>	
CREATION : 26/04/21	ASSEMBLY : <b>32-57-1041</b>
REVISION : 26/04/21	AUTHOR : J. Houle

#	PART #	Qty	TITLE
1	NCI3-30-0237	1	PLASTIC TUBE FOR OPERATOR'S MANUAL
2	NC01-04-0003	3	BOLT CARR. GR2 ZINC 1/4-20 X 3/4"
3	NC02-25-0007	3	WASHER ZINC 0.281 = 9/32
4	NC01-96-0009	3	NYLON-INSERT LOCKNUT ZINC 1/4-20
5	32-98-0626	1	OPERATOR MANUAL BW 2500-3500-4500

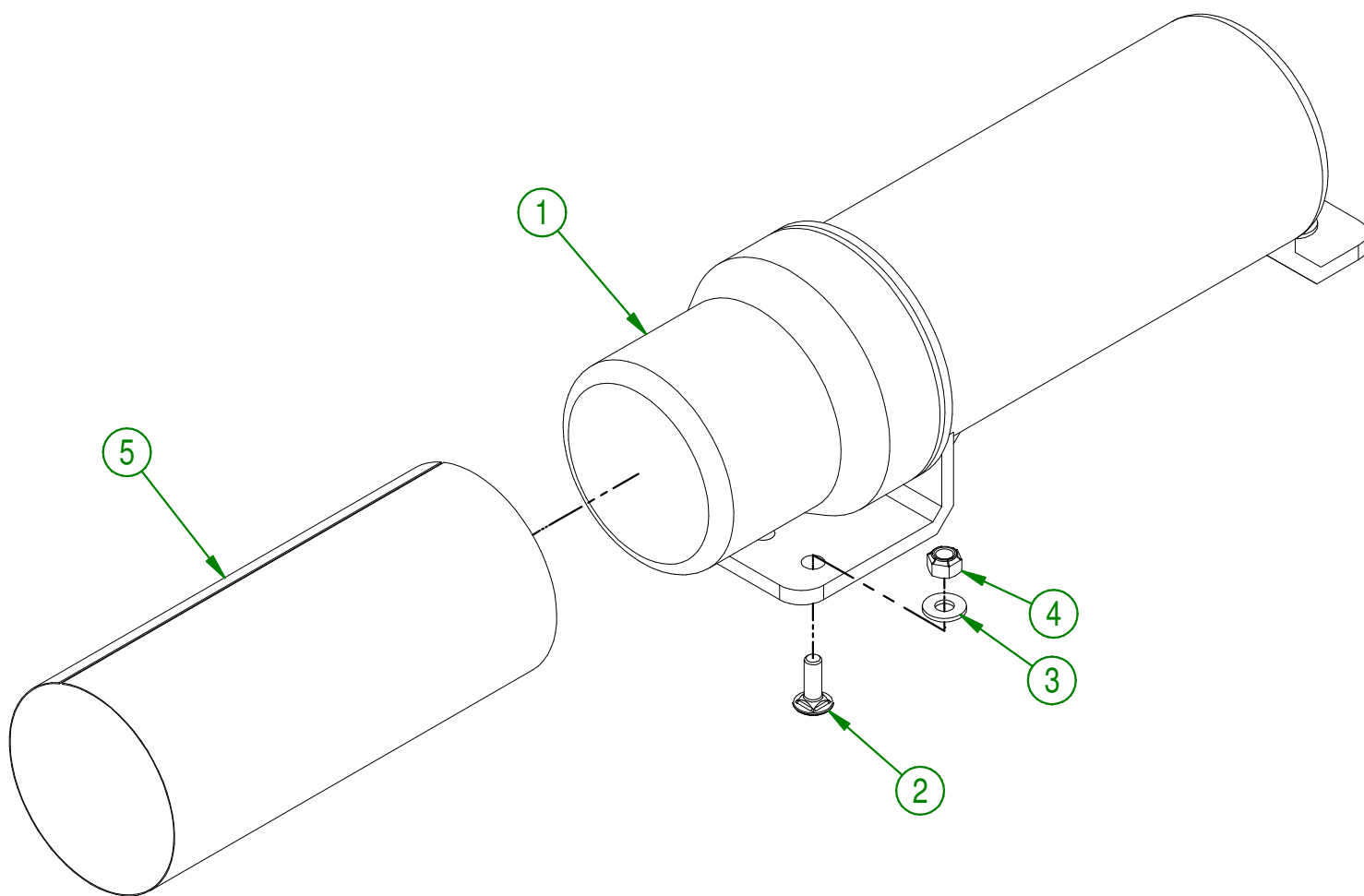

<b>AGRIMETAL</b>	
<b>OPERATOR MANUEL</b>	
CREATION : 13/03/17	ASSEMBLY : <b>32-57-1105</b>
REVISION : 05/01/18	AUTHOR : F.HÉLIE

#	PART #	Qty	TITLE
1	NCI3-33-0024	4	STICKER GREASE HERE
2	NCI3-33-2686	1	STICKER IMPORTANT
3	NCI3-33-0305	1	STICKER 75 dB
4	NCI3-33-0183	1	STICKER CAUTION OPERATION MANUAL
5	NCI3-33-0035	2	STICKER AGRIMETAL
6	NCI3-33-0005	1	STICKER MAXIMUM 540 RPM
7	NCI3-33-0287	1	STICKER WARNING
8	NCI3-33-0298	2	STICKER PULL THIS WAY TO OPEN
9	NCI3-33-0179	1	STICKER IMPORTANT GREASE DRIVE LINE
10	NCI3-33-0187	1	STICKER DANGER (PTO AND PERSON)
11	NCI3-33-0192	3	STICKER (PROJECTION RISK)
12	NCI3-33-0290	1	STICKER DANGER
13	NCI3-33-0348	2	STICKER B-50
14	NCI3-33-0186	1	STICKER (DANGER)
15	NCI3-33-0163	1	STICKER LOW DECIBEL

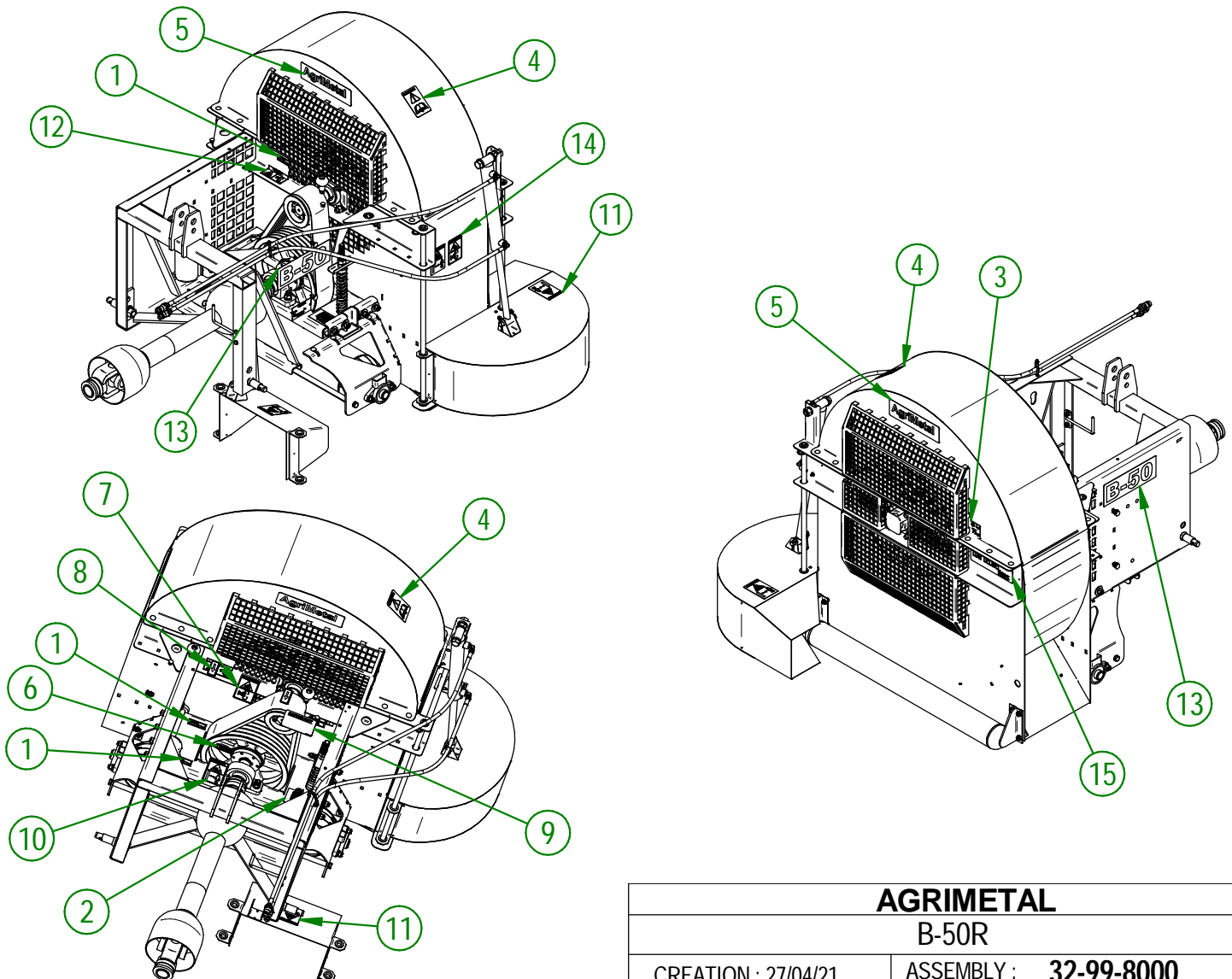
**AGRIMETAL****B-50R**

CREATION : 27/04/21  
 REVISION : 01/05/25

ASSEMBLY : **32-99-8000**

AUTHOR : G. Huberdeau