

AgriMetal

PARTS LIST

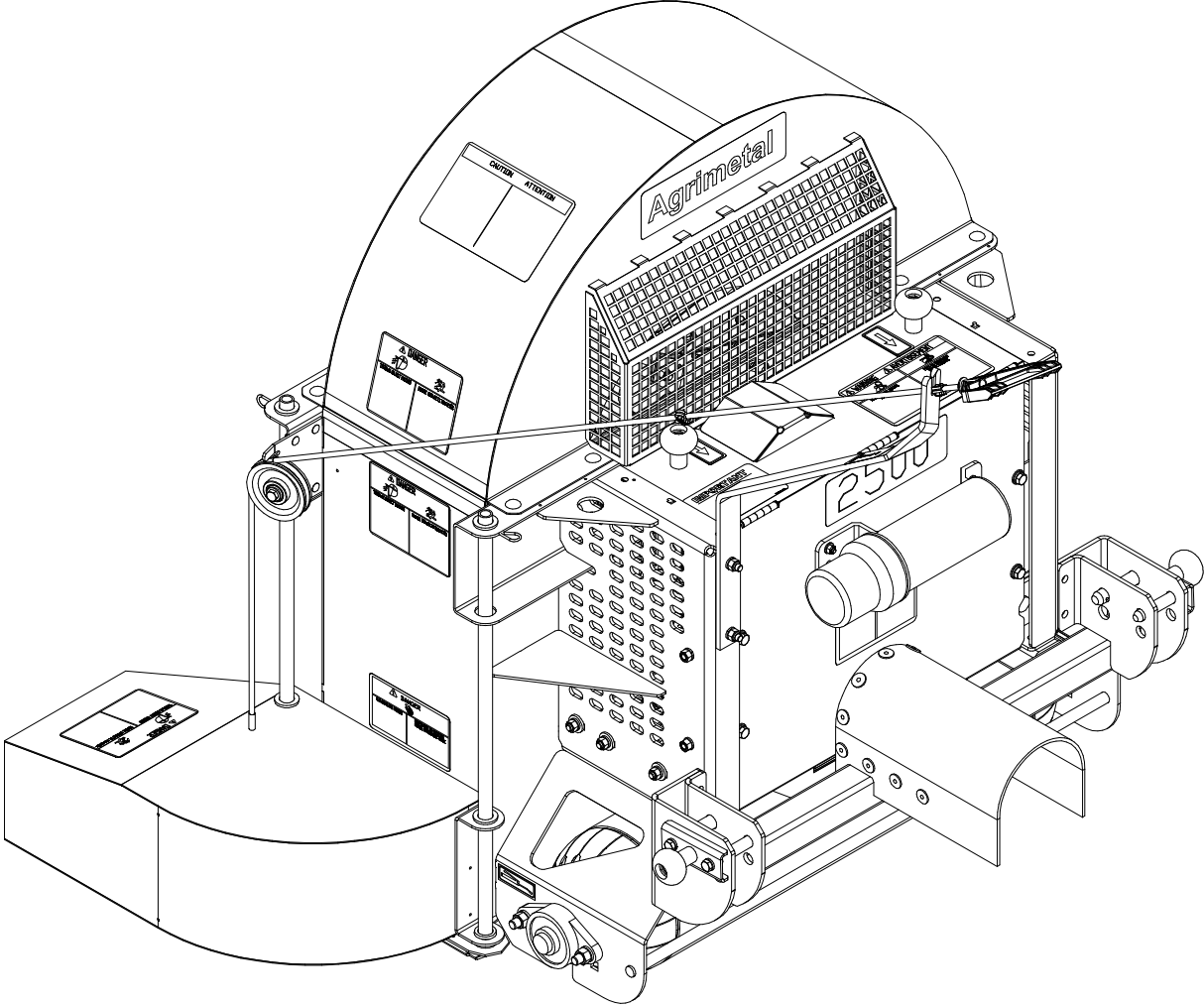

BW 2500-F KUB-80

32-57-3750

#	PART #	Qty	TITLE
1	NC17-46-0023	4	BUSHING 0.810" ID X 1.310" OD X 0.460"
2	25-55-0710	1	SERIAL NUMBER PLATE

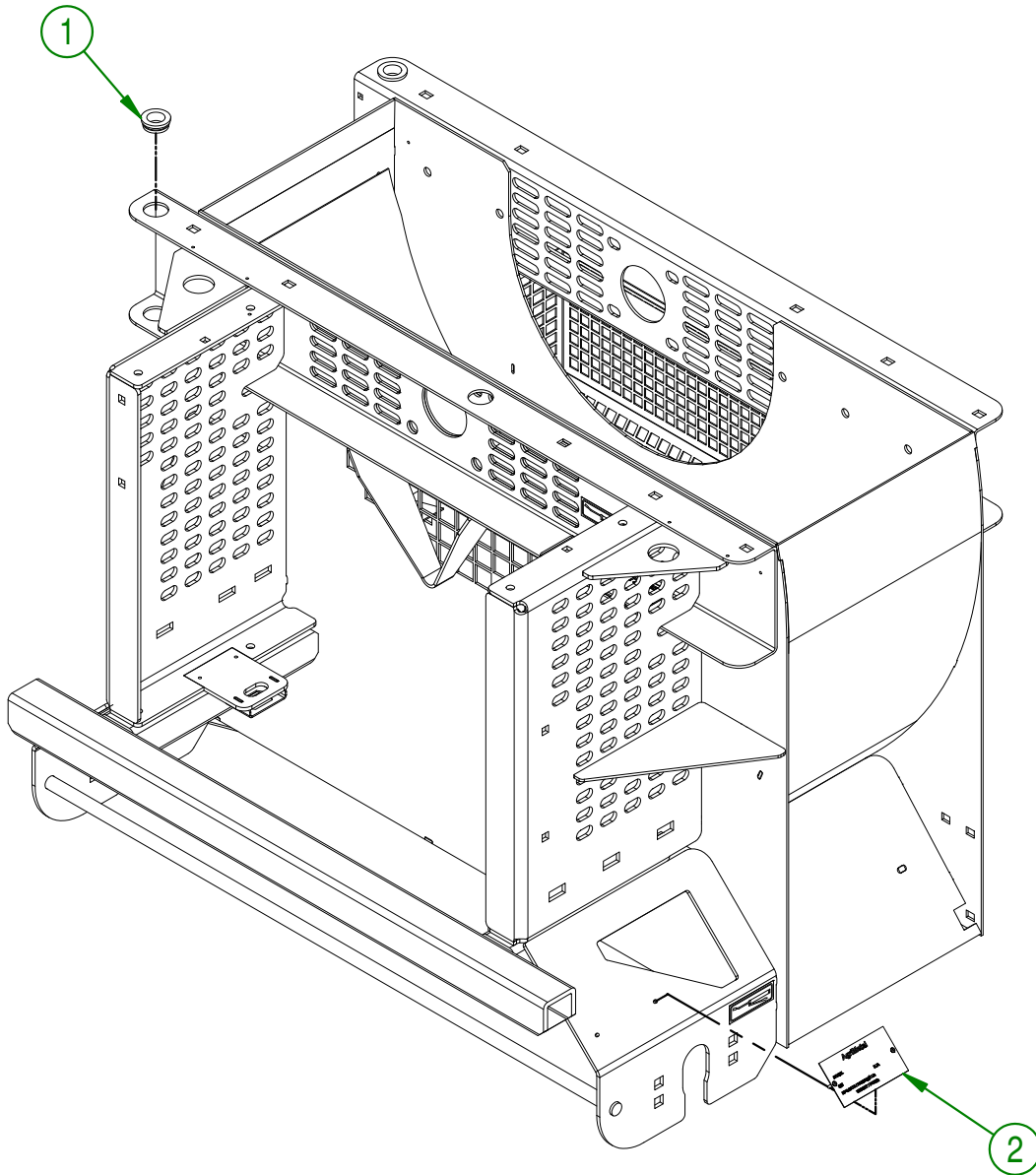

AGRIMETAL			
ASSEMBLY CASING			
CREATION : 23-06-2016	ASSEMBLY :	32-57-3750	
REVISION : 06-08-2018	AUTHOR : S.B.	Page 1 de 15	

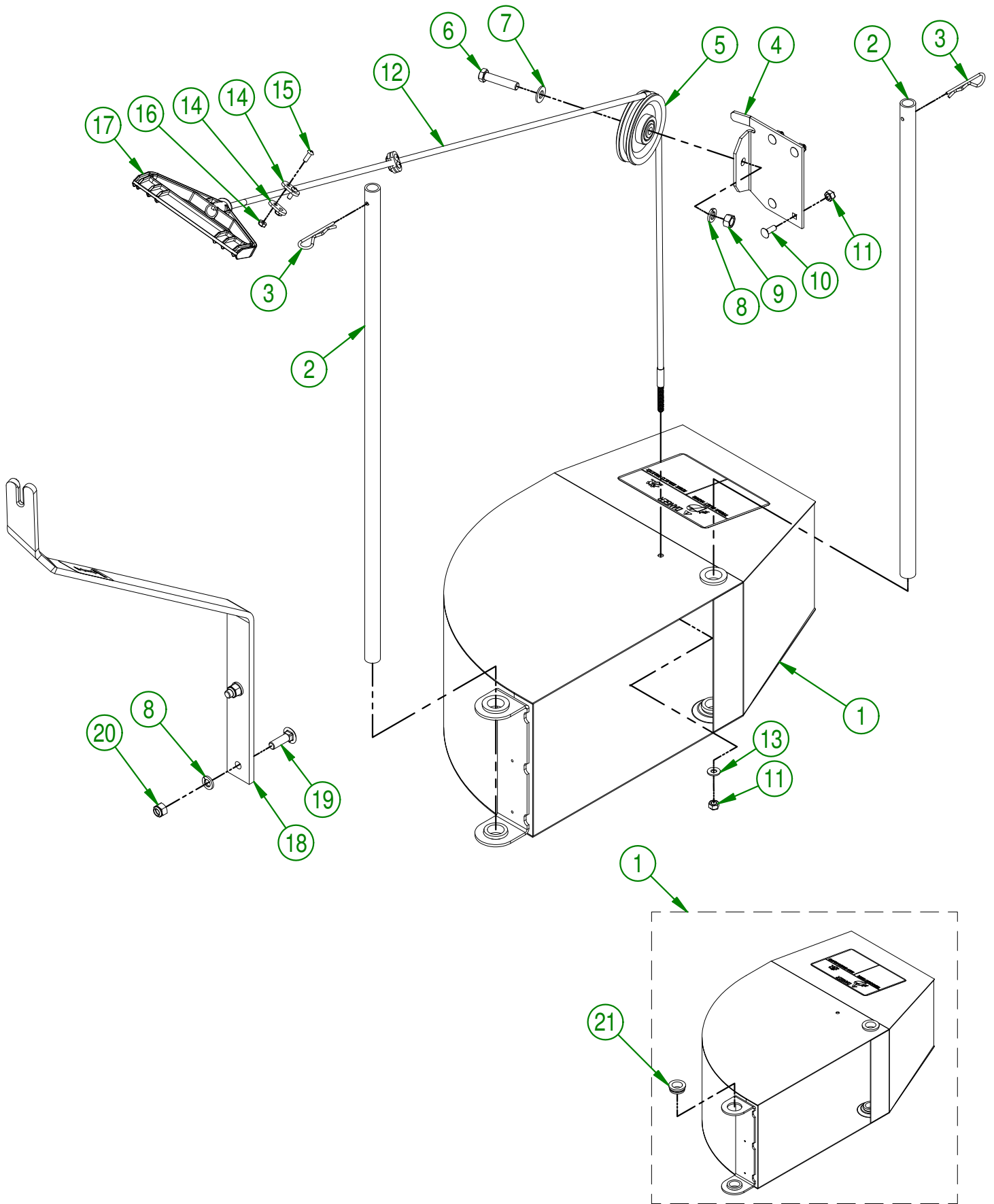

AGRIMETAL		
ASSEMBLY DEFLECTOR COMPL.		
CREATION : 06-07-2016	ASSEMBLY :	32-57-3591
REVISION : 06-03-2019	AUTHOR :	Page 2 de 15

32-57-3591

#	PART #	Qty	TITLE
1	32-55-3576	1	ASSEMBLY DEFLECTOR
2	32-11-2505	2	DEFLECTOR GUIDE
3	NC01-63-0015	2	COTTER PIN Z 1/8" X 2 5/8"
4	32-01-1390	1	PULLEY SUPPORT
5	NC14-63-0001	1	PULLEY PLASTIC 3 1/2" OD X BEARING 3/8"
6	NC01-17-0117	1	HEX. BOLT GR2 ZINC 3/8-16 X 1 3/4"
7	01-01-2485	1	FLAT WASHER 14 GA X 13/16"OD X 25/64" ID
8	NC02-32-0012	3	LOCK WASHER ZINC 3/8"
9	NC02-07-0018	1	HEX. NUT ZINC 3/8-16
10	NC01-04-0002	4	CARR. BOLT GR2 ZINC 1/4-20 X 5/8"
11	NC01-96-0009	5	NYLON-INSERT LOCKNUT ZINC 1/4-20
12	NC17-02-0140	1	ASSEMBLY DEFLECTOR CABLE BW 2500-F 71 1/4"
13	NC02-25-0007	1	WASHER ZINC 0.281 = 9/32
14	32-22-5600	4	BRACKET FOR CABLE
15	NC02-40-0082	4	MACHINE SCREW PHILLIPS ZINC 10-24 OU 3/16"
16	NC01-96-0006	4	NYLON NUT ZINC 10-24
17	NC13-80-0065	1	STARTER HANDLE
18	32-57-3530	1	CABLE SUPPORT WITH STICKER
19	NC01-04-0110	2	CARR. BOLT GR2 ZINC 3/8-16 X 1 1/4"
20	NC01-96-0011	2	NYLON NUT 3/8-16

32-55-3576

#	PART #	Qty	TITLE
21	NC17-46-0023	4	BUSHING 0.810" ID X 1.310" OD X 0.460"

AGRIMETAL**ASSEMBLY DEFLECTOR COMPL.**

CREATION : 06-07-2016	ASSEMBLY :	32-57-3591
REVISION : 06-03-2019	AUTHOR :	Page 3 de 15

#	PART #	Qty	TITLE
1	32-46-0000	1	FRONT ROLLER
2	NC13-80-0061	4	PAD STEEL POWDER 1/2" X 5/8" X 3/8"
3	NC02-32-0014	4	LOCK WASHER ZINC 1/2"
4	NC02-07-0020	4	HEX. NUT ZINC 1/2-13
5	32-38-0015	2	FLANGE BEARING UCFL206-18 X 1 1/8" - GREASE FITTING 1/4-28"
6	NC01-04-0235	4	CARR. BOLT GR2 ZINC 1/2-13 X 1 1/2"

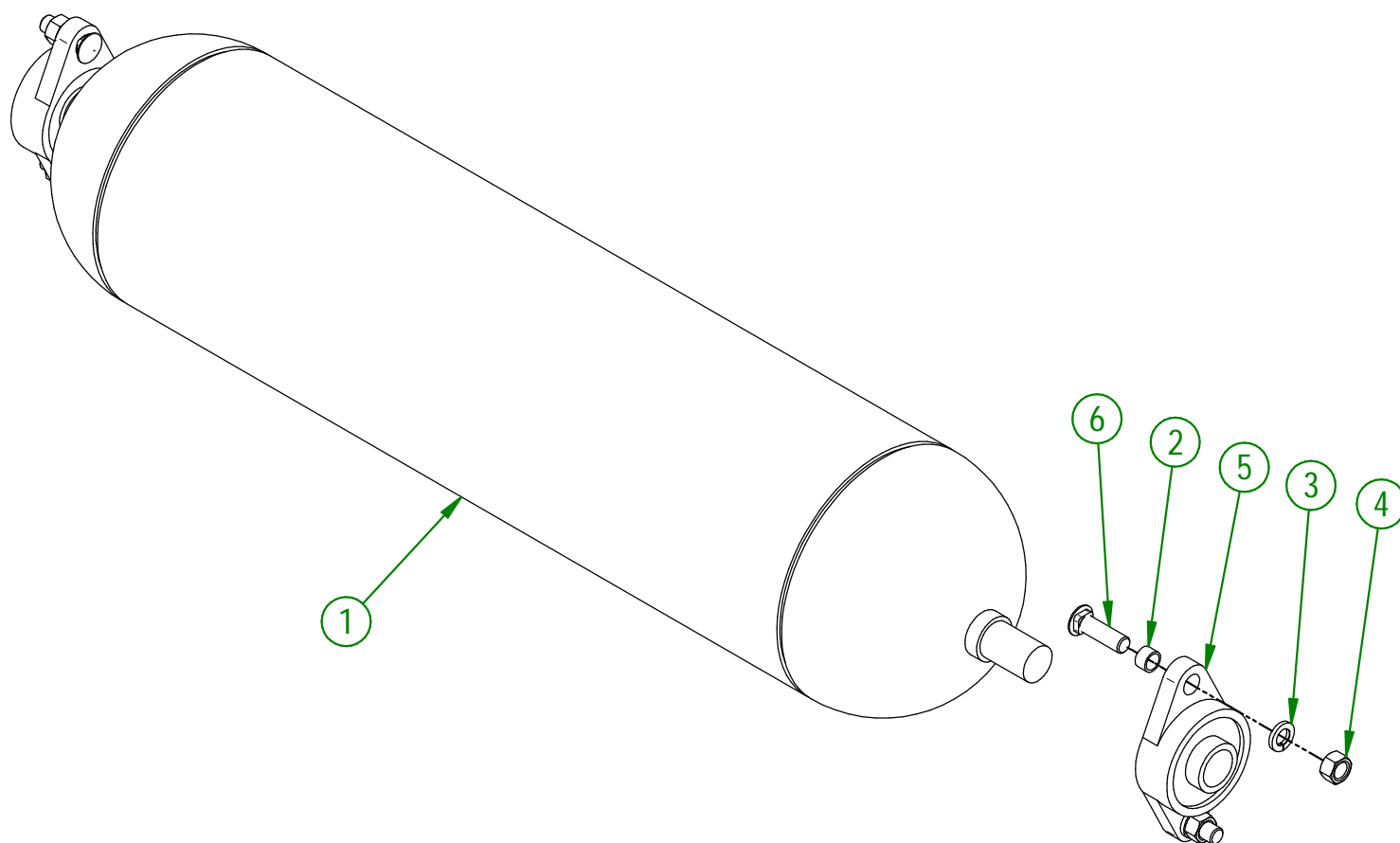

AGRIMETAL	
ASSEMBLY LARGE TURF ROLLER	
CREATION : 2016-06-21	ASSEMBLY : 32-57-3025
REVISION : 2025-12-23	AUTHOR : S.B.

32-57-3030

#	PART #	Qty	TITLE
1	32-55-3070	1	ASSEMBLY SMALL TURF ROLLER
2	32-50-1056	1	LEFT SMALL TURF ROLLER SUPPORT
3	32-50-1061	1	RIGHT SMALL TURF ROLLER SUPPORT
4	NC01-04-0107	8	CARR. BOLT GR2 ZINC 3/8-16 X 3/4"
5	NC02-14-0019	8	FLANGE NUT HEX. NC 3/8-16 GR. B

32-55-3070

#	PART #	Qty	TITLE
6	32-11-3520	1	TURF ROLLER ONLY (REAR)
7	32-42-0105	2	REAR ROLL CAP

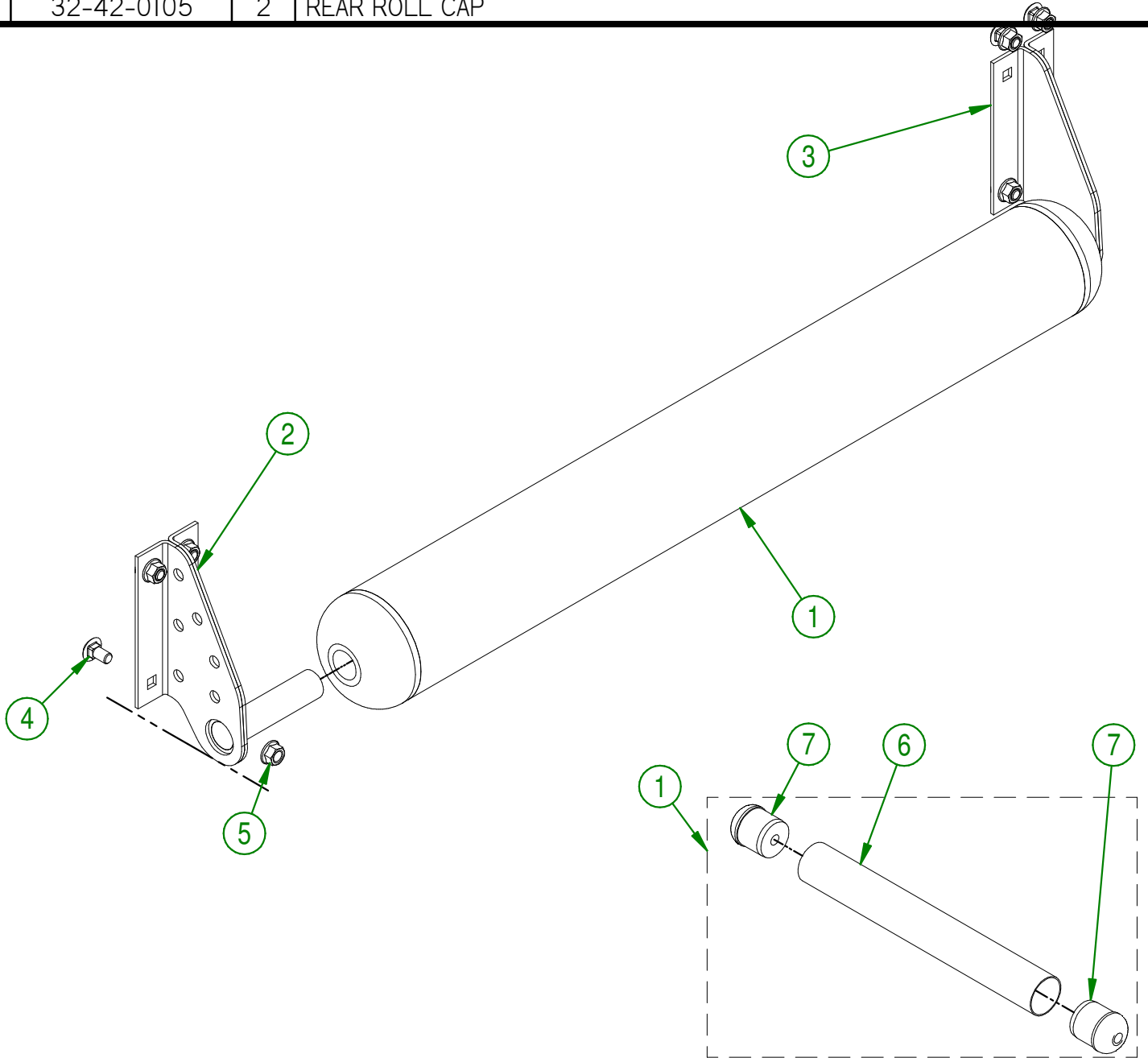

AGRIMETAL	
ASSEMBLY SMALL TURF ROLLER	
CREATION : 21-06-2016	ASSEMBLY : 32-57-3030
REVISION : 11-08-2021	AUTHOR :

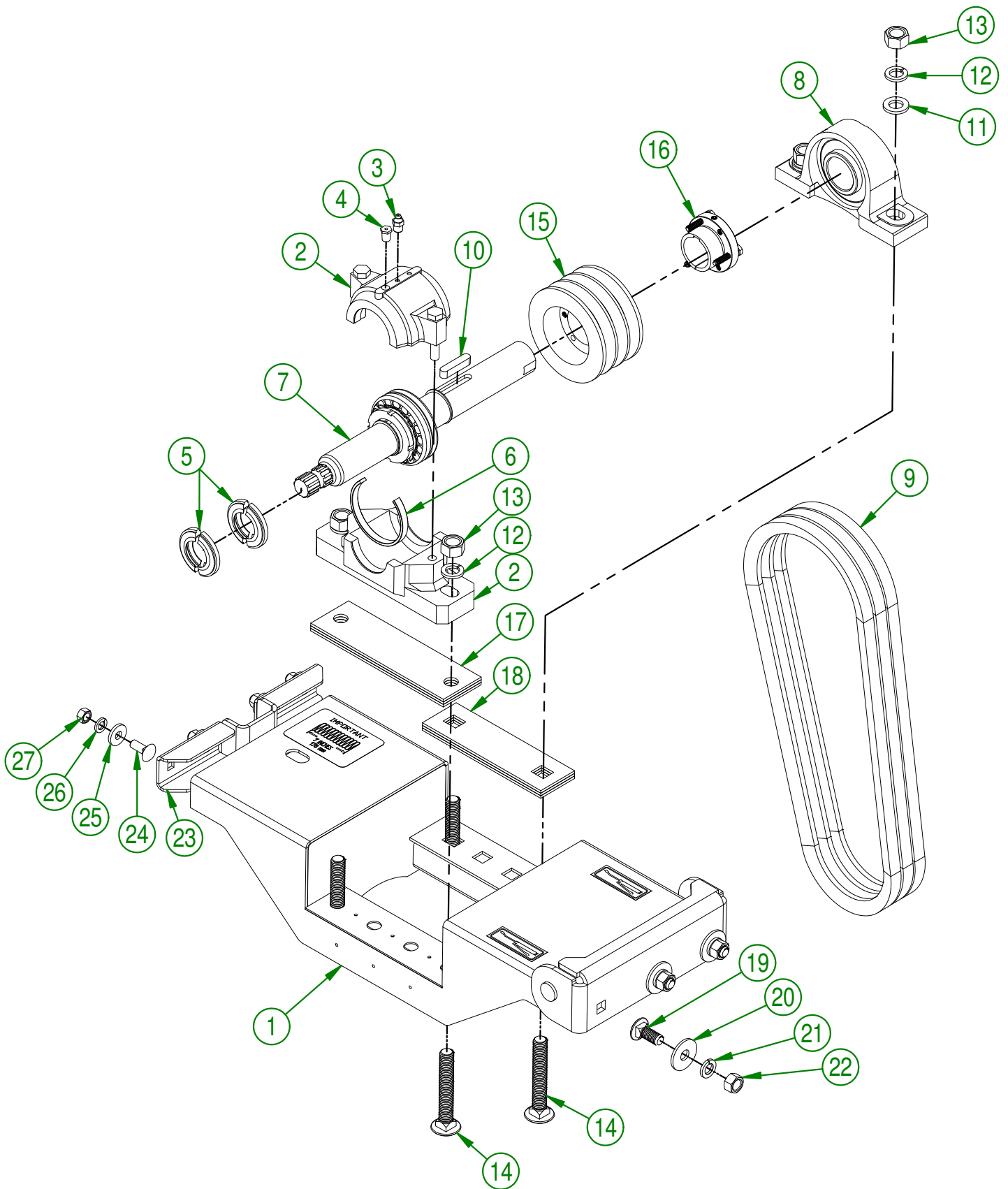

AGRIMETAL			
BEARING BASE GROUP			
CREATION : 23-06-2016	ASSEMBLY :	32-57-3536	
REVISION : 24-10-2018	AUTHOR :	Page 6 de 15	

#	PART #	Qty	TITLE
1	32-57-4020	1	ASSEMBLY BEARING BASE
2	NC14-75-0131	1	PILLOW BLOCK CASING
3	NC01-69-0791	1	GREASE FITTING 1/8 NPT STRAIGHT
4	32-45-0000	1	BEARING PLUG
5	NC14-75-0130	1	SET JOINT 1 1/2"
6	NC14-75-0129	1	BEARING SHIM 1 1/2"
7	32-55-3564	1	ASSEMBLY DRIVE SHAFT
8	NC14-75-0035	1	PILLOW BLOCK SUPPORT UCP208-24 Ø 1 1/2"
9	NC14-25-1084	3	V BELT 21/32 COGGED RAW EDGE BX-45
10	NC01-65-0100	1	KEY 3/8 X 3/8 X 1 3/4"
11	32-01-1395	2	BEARING WHASER Ø 3/4"
12	NC02-32-0016	4	LOCK WASHER ZINC 5/8"
13	NC02-07-0022	4	HEX. NUT ZINC 5/8-11
14	NC01-04-0276	4	BOLT CARR. GR2 ZINC 5/8-11 X 4"
15	NC14-62-0096	1	PULLEY QD 3V 1/2-5/8 X 4.55 OD X SH
16	NC14-62-0221	1	QD BUSHING SH 1 1/2"
17	32-03-6000	3	BEARING SHIM
18	32-03-6005	3	BEARING SHIM
19	NC01-04-0234	3	CARR. BOLT GR2 ZINC 1/2-13 X 1 1/4
20	01-01-1660	3	WASHER SPACER
21	NC02-32-0014	3	LOCK WASHER ZINC 1/2"
22	NC02-07-0020	3	HEX. NUT ZINC 1/2-13
23	32-01-1125	2	BEARING BASE STOPPER
24	NC01-04-0109	4	CARR. BOLT GR2 ZINC 3/8-16 X 1"
25	21-01-0950	4	FLAT WASHER 10GA 1.005" DIA X 25/64"
26	NC02-32-0012	4	LOCK WASHER ZINC 3/8"
27	NC02-07-0018	4	HEX. NUT ZINC 3/8-16

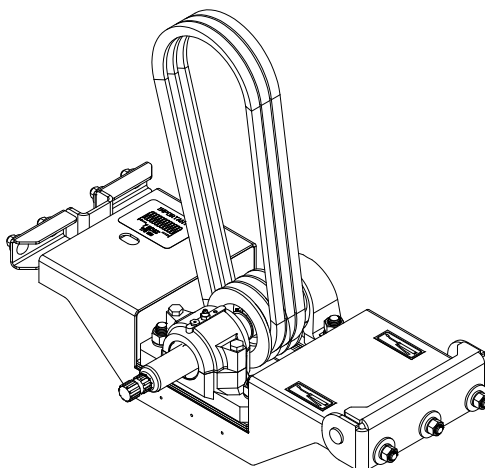
**AGRIMETAL****BEARING BASE GROUP**

CREATION : 23-06-2016	ASSEMBLY :	32-57-3536
REVISION : 24-10-2018	AUTHOR :	

#	PART #	Qty	TITLE
1	NC17-46-0018	2	HANDLE KNOB
2	NC01-17-0119	2	HEX. BOLT GR2 ZINC 3/8-16 X 2 1/4"
3	01-01-2485	6	FLAT WASHER
4	NC02-32-0012	6	LOCK WASHER ZINC 3/8"
5	NC02-07-0018	2	HEX. NUT ZINC 3/8-16
6	32-42-0040	1	BLACK RUBBER SN60 3/16" X 12" X 15 7/8"
7	16-01-2720	13	WASHER 13/16" DIA. X 13/64"
8	NC01-78-0016	13	ALUMINIUM BLIND POP RIVET STEEL MANDREL 0.187 X 0.690
9	32-50-3542	1	BELT GUARD
10	NC01-17-0112	4	HEX. BOLT GR2 ZINC 3/8-16 X 3/4"
11	NC01-04-0055	2	CARR. BOLT GR2 ZINC 5/16-18 X 5/8"
12	NC01-96-0010	2	NYLON NUT HEX. ZINC 5/16-18

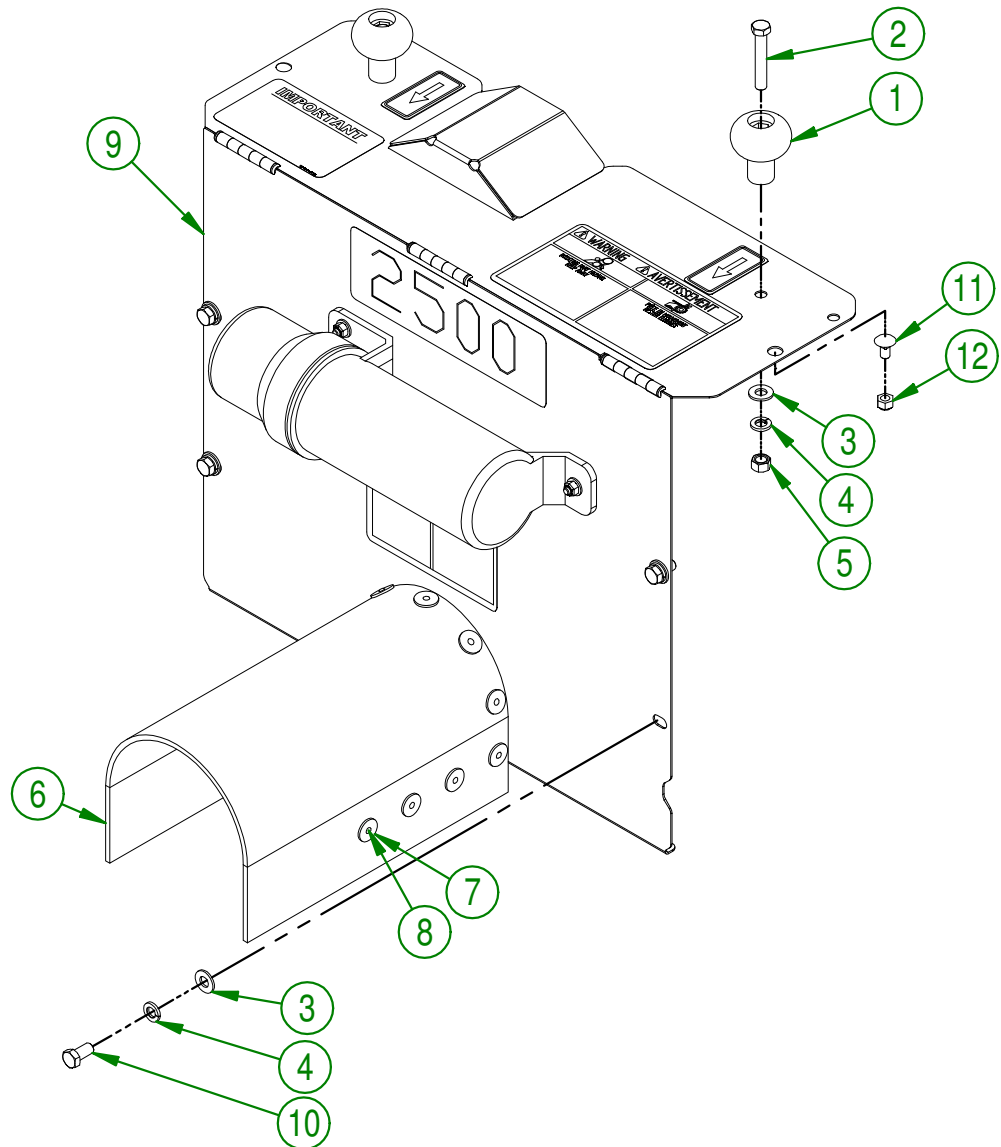
**AGRIMETAL****ASSEMBLY BELT COVER**

CREATION : 2016-07-06

ASSEMBLY :

32-57-3586

REVISION : 2018-03-06

AUTHOR : S.B.

Page 8 de 15

#	# DE PIÈCE	Qty	TITLE
1	32-50-3030	1	WELD ASSEMBLY THREADED ROD
2	NC02-22-0013	1	WASHER ZINC 5/8 ID X 1 1/2 OD
3	32-42-0135	1	SPRING GUIDE
4	12-44-0015	1	RED SPRING 1 1/2" OD 1" ID X 8 1/2"
5	32-42-0130	1	SPRING STOPPER
6	NC02-07-0022	2	HEX. NUT ZINC 5/8-11
7	32-01-3170	1	TENSIONER HANDLE

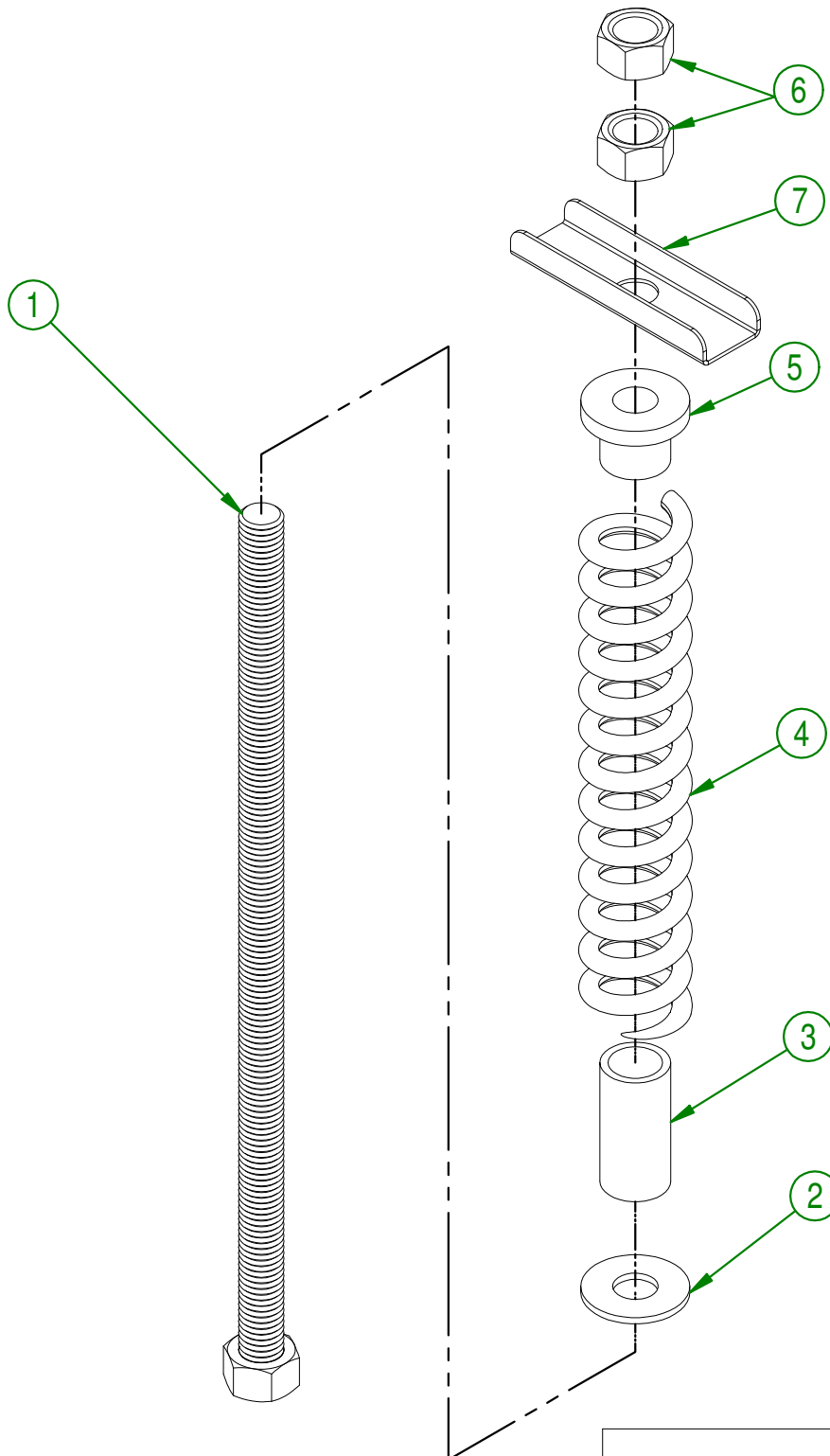

AGRIMETAL			
ASSEMBLY TENSIONER			
CREATION : 2016-06-21	ASSEMBLY :	32-57-3040	
REVISION : 2018-01-10	AUTHOR : S.B.	Page 9 de 15	

#	# DE PIÈCE	Qty	TITLE
1	32-50-3040	1	WELD ASSEMBLY BRACKET BELT COVER
2	NC01-04-0107	2	CARR. BOLT GR2 ZINC 3/8-16 X 3/4"
3	NC02-32-0012	2	LOCK WASHER ZINC 3/8"
4	NC02-07-0018	2	HEX. NUT ZINC 3/8-16

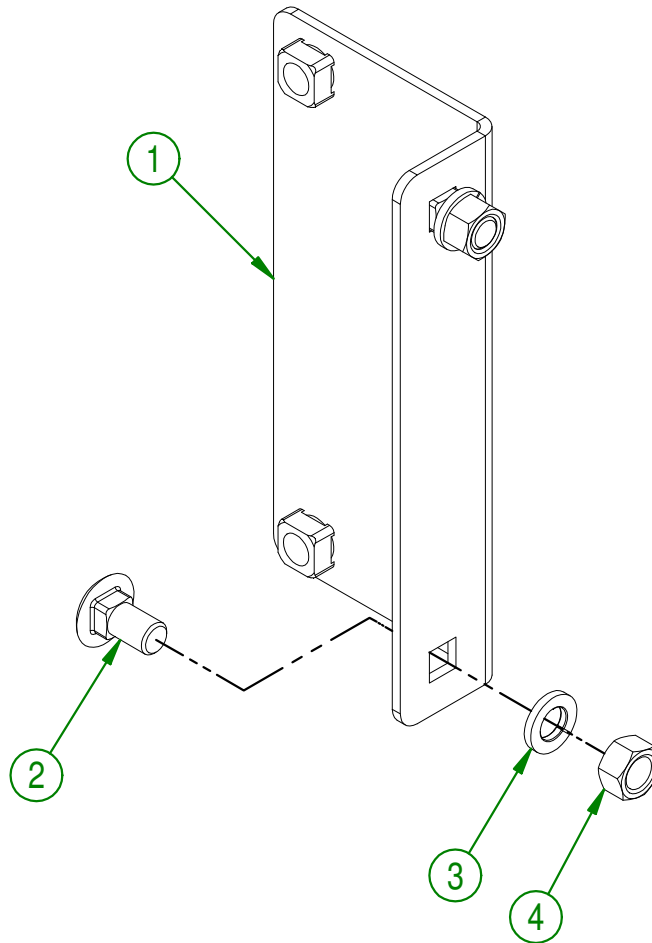

AGRIMETAL		
ASSEMBLY BRACKET BELT COVER		
CREATION : 2016-06-21	ASSEMBLY :	32-57-3055
REVISION : 2018-01-10	AUTHOR : S.B.	Page 10 de 15

#	PART #	Qty	TITLE
1	NCI7-94-0008	1	IMPELLER SHAFT
2	NCI4-75-0025	1	FLANGE BEARING 4 HOLES UCF 208-24 X 1 1/2"
3	NC01-17-0396	4	HEX. BOLT GR2 ZINC 5/8-11 X 2"
4	NC02-32-0016	4	LOCK WASHER ZINC 5/8"
5	NC02-07-0022	4	HEX. NUT ZINC 5/8-11
6	32-09-2000	3	IMPELLER SPACER
7	NCI4-75-0024	1	FLANGE BEARING 4 HOLES UCF207-20 1 1/4" DIA.
8	12-01-3051	1	REAR BEARING PROTECTOR
9	NC01-17-0250	4	HEX. BOLT GR2 ZINC 1/2-13 X 1 3/4"
10	NC02-25-0011	4	WASHER SAE ZINC 17/32 ID
11	NC02-32-0014	4	LOCK WASHER ZINC 1/2"
12	NC02-07-0020	4	HEX. NUT ZINC 1/2-13
13	32-55-3050	1	IMPELLER
14	NC01-98-0022	1	NYLON NUT HEX. 1 3/8-12 THIN
15	NCI4-62-0202	1	PULLEY QD 3VI/2-5/8 X 7.35 OD X SK (3B70)
16	NCI4-62-0021	1	QD BUSHING SK 1 1/2"
17	32-41-0900	1	IMPELLER KEY
18	12-41-0915	1	PULLEY KEY

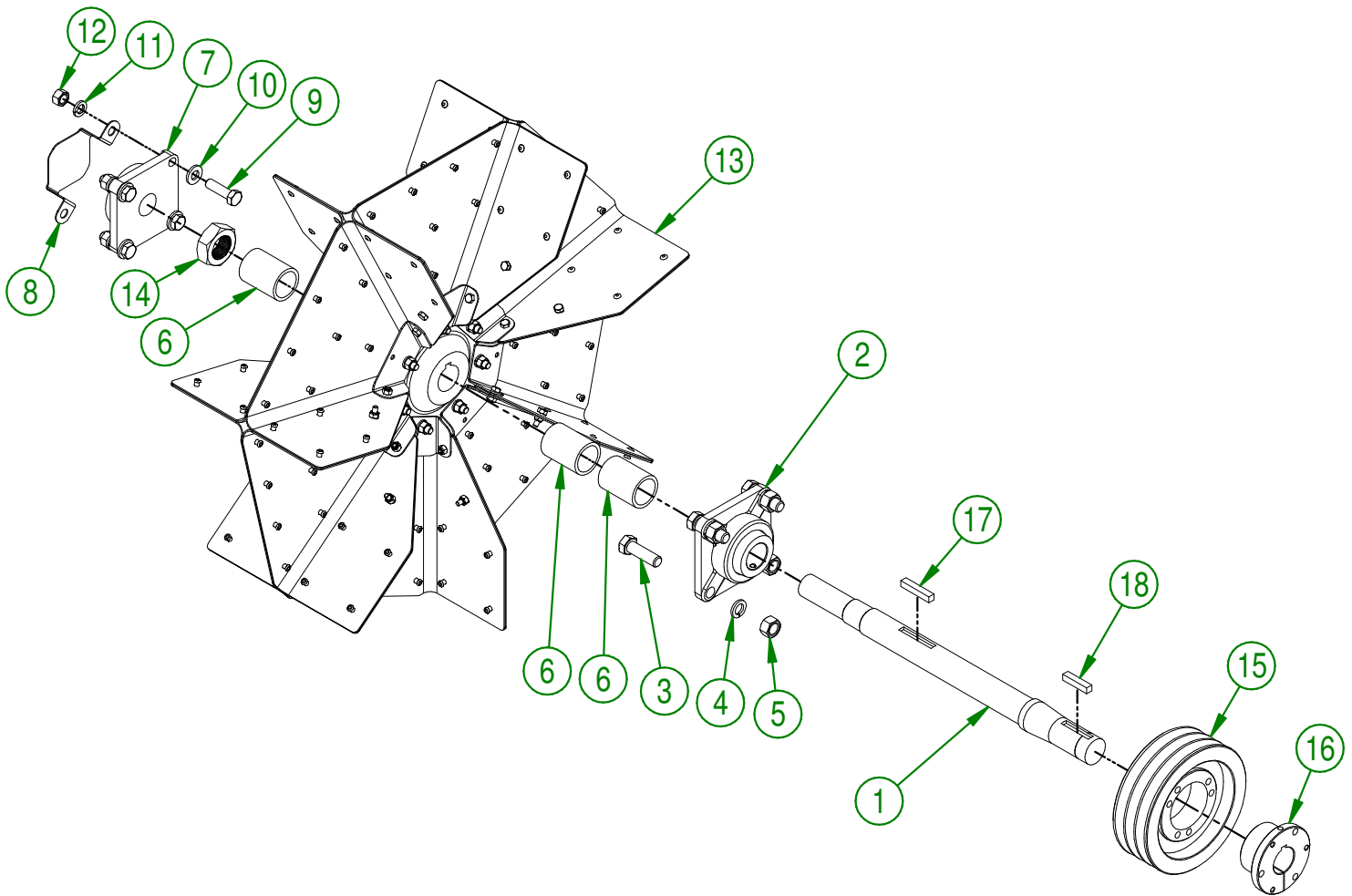

USE THESE PIECES ONLY IF YOUR SERIAL NUMBER IS AFFECTED:

#39750 AND UNDER

AGRIMETAL	
ASSEMBLY IMPELLER	
CREATION : 2016-06-21	ASSEMBLY : 32-57-3545
REVISION : 2021-02-15	AUTHOR : S.B.

32-57-3548

#	PART #	Qty	TITLE
1	NC14-75-0025	1	FLANGE BEARING 4 HOLES UCF 208-24 X 1 1/2"
2	NC01-17-0396	4	HEX. BOLT GR2 ZINC 5/8-11 X 2"
3	NC02-32-0016	4	LOCK WASHER ZINC 5/8"
4	NC02-07-0022	4	HEX. NUT ZINC 5/8-11
5	NC14-75-0024	1	FLANGE BEARING 4 HOLES UCF207-20 1 1/4" DIA.
6	12-01-3051	1	REAR BEARING PROTECTOR
7	NC01-17-0250	4	HEX. BOLT GR2 ZINC 1/2-13 X 1 3/4"
8	NC02-25-0011	4	WASHER SAE ZINC 17/32 ID
9	NC02-32-0014	4	LOCK WASHER ZINC 1/2"
10	NC02-07-0020	4	HEX. NUT ZINC 1/2-13
11	32-57-6100	1	IMPELLER
12	NC14-62-0202	1	PULLEY QD 3VI/2-5/8 X 7.35 OD X SK (3B70)
13	NC14-62-0021	1	QD BUSHING SK 1 1/2"
14	12-41-0915	1	PULLEY KEY

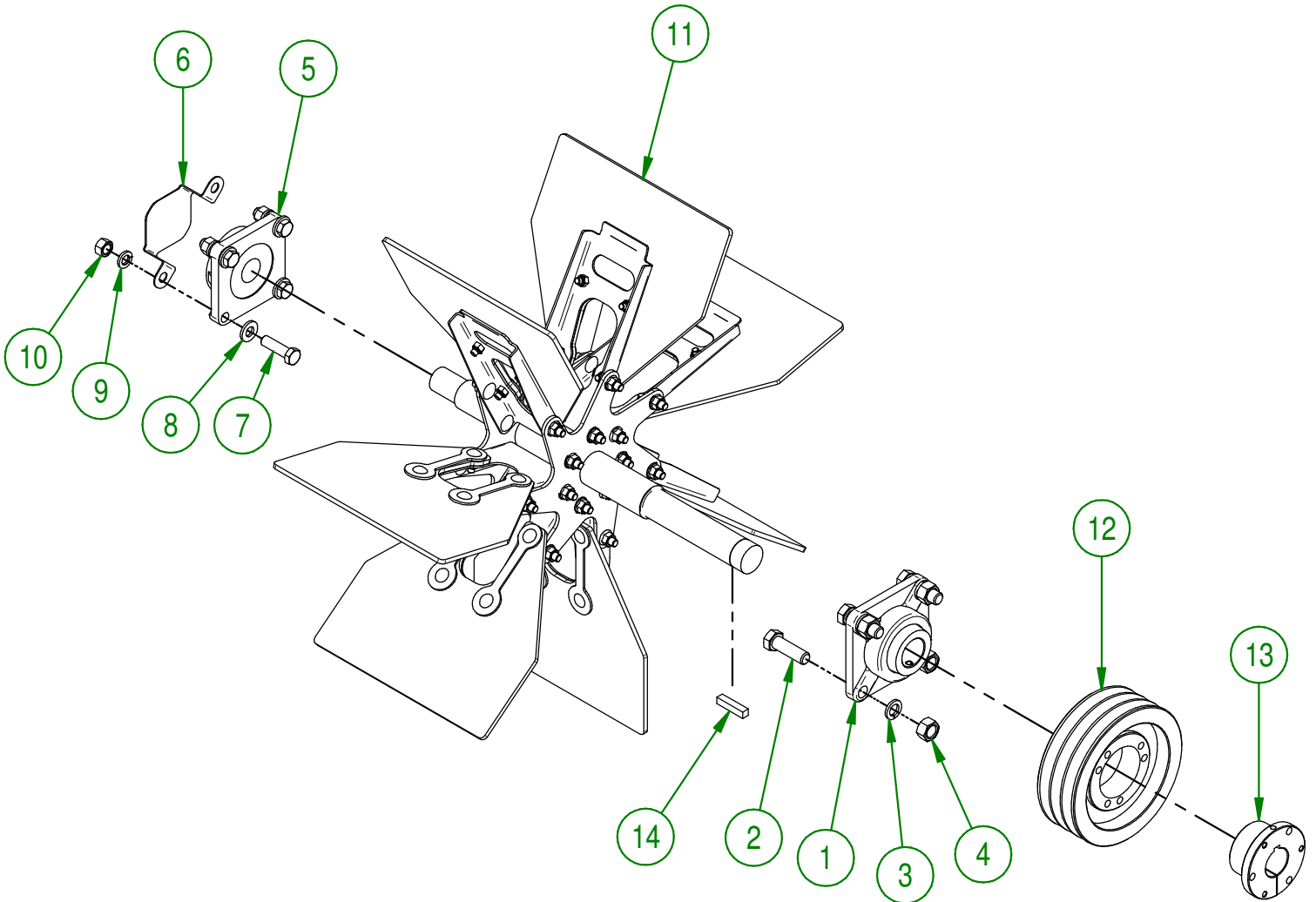

UTILISER CES PIÈCES SEULEMENT SI VOTRE NUMÉRO DE SÉRIE EST CONCERNÉ:

#39751 ET PLUS

AGRIMETAL
ASSEMBLY IMPELLER

CREATION : 21/10/21
REVISION : 21/10/21

ASSEMBLY : **32-57-3548**
AUTHOR : J. Houle

32-57-6100

#	PART #	Qty	TITLE
1	32-50-6100	1	IMPELLER
2	NC17-14-0012	7	IMPELLER PADDLE
3	32-01-0000	14	PADDLE BRACE
4	NC01-04-0058	28	CARRAGE BOLT 5/16-18 X 1"
5	NC01-96-0010	28	NYLON NUT HEX. ZINC 5/16-18

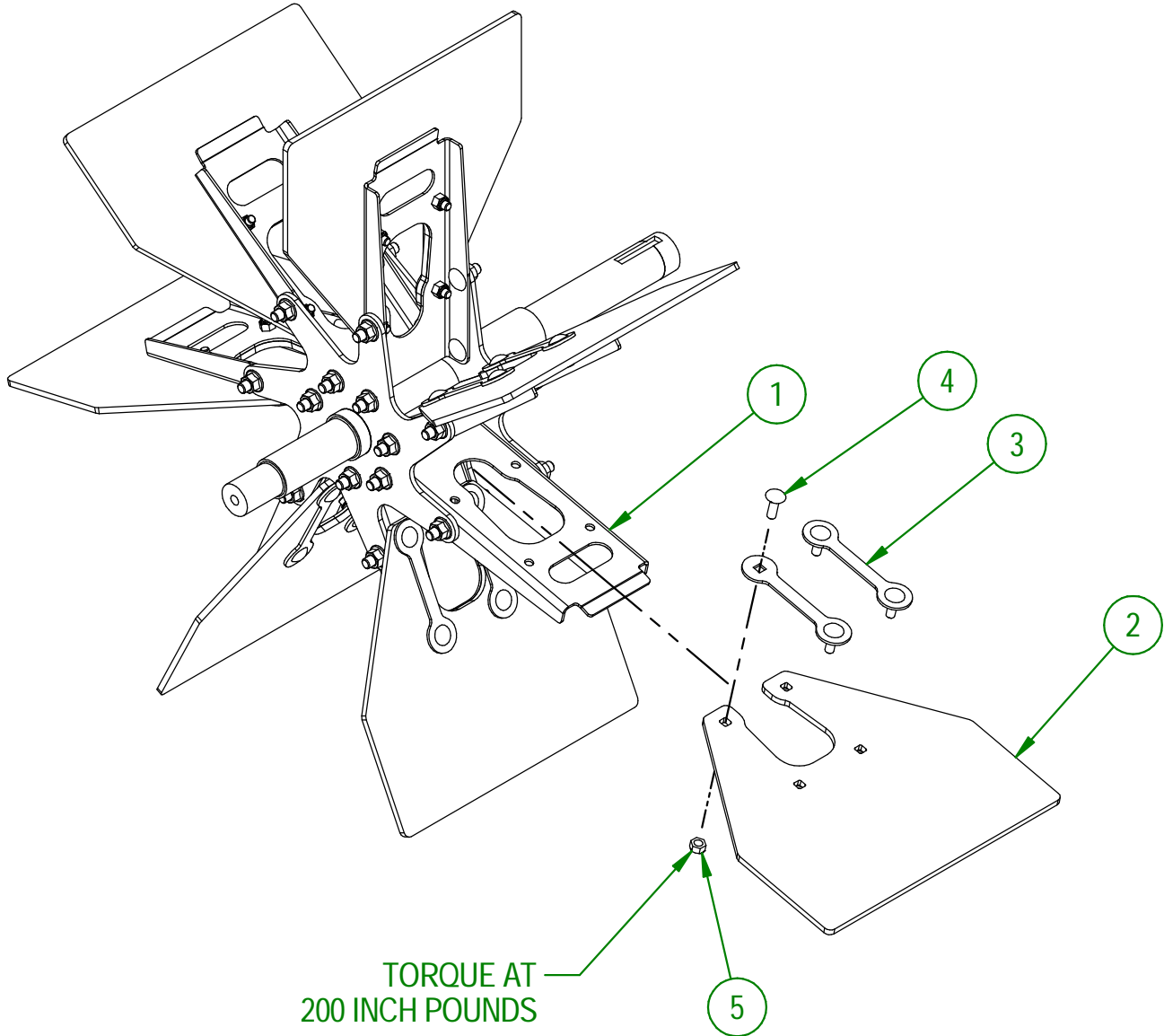

AGRIMETAL	
IMPELLER	
CREATION : 04/03/21	ASSEMBLY : 32-57-6100
REVISION : 11/05/22	AUTHOR : J. Houle

#	PART #	Qty	TITLE
1	32-57-3525	1	WELD ASSEMBLY COVER CASING
2	NC01-04-0107	8	CARR. BOLT GR2 ZINC 3/8-16 X 3/4"
3	NC02-14-0019	10	FLANGE NUT HEX. NC 3/8-16 GR. B

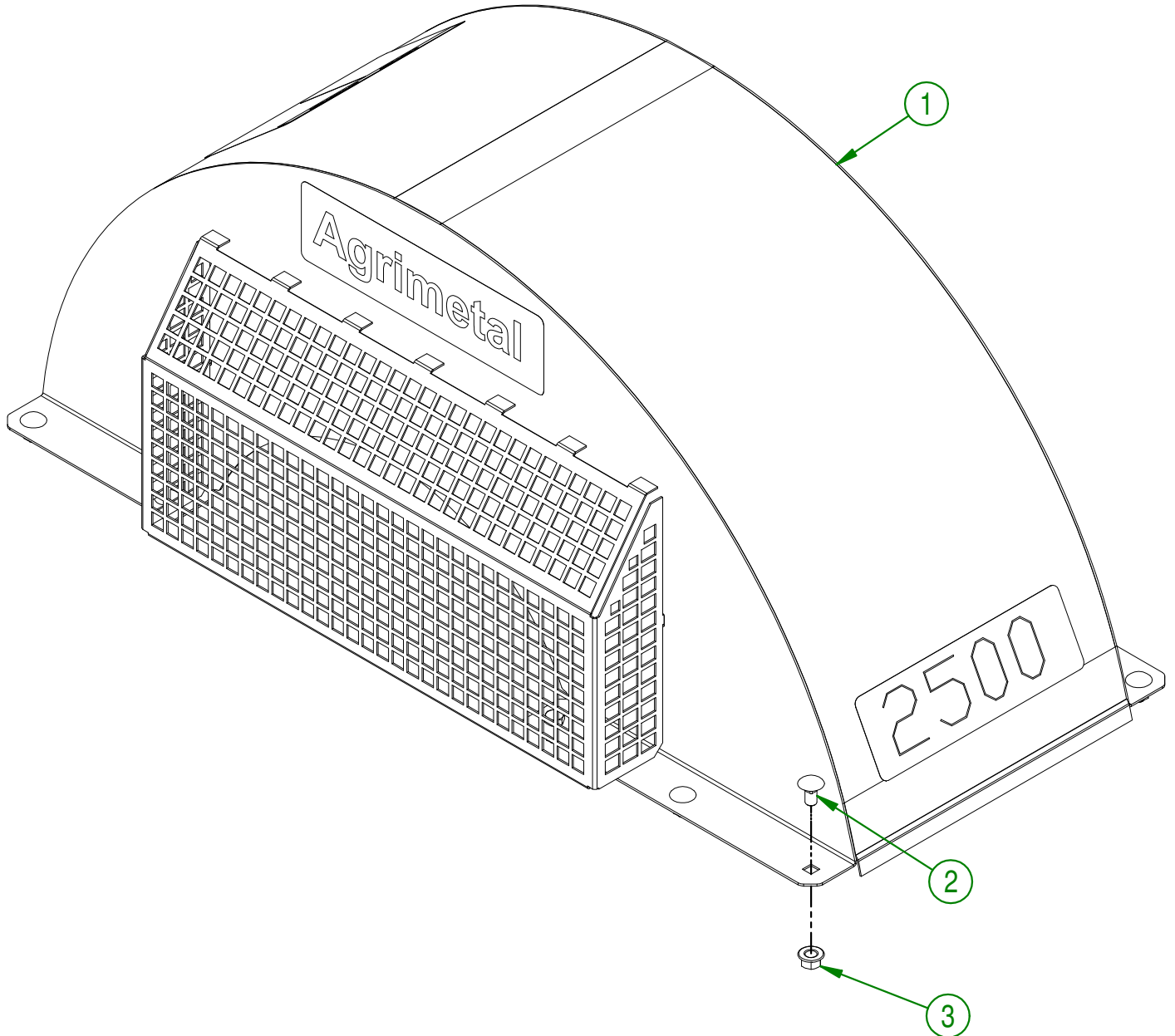

AGRIMETAL		
ASSEMBLY COVER CASING		
CREATION : 2018-03-05	ASSEMBLY :	32-57-3555
REVISION : 2018-03-05	AUTHOR :	Page 12 de 15

#	# DE PIÈCE	Qty	TITLE
1	32-01-1355	1	LOCK SUPPORT
2	32-13-0800	1	SMALL PIN
3	32-13-1010	1	LARGE PIN
4	NC01-17-0114	2	HEX. BOLT GR2 ZINC 3/8-16 X 1"
5	NC02-32-0012	3	LOCK WASHER ZINC 3/8"
6	NC17-46-0018	1	HANDLE KNOB
7	NC01-17-0119	1	HEX. BOLT GR2 ZINC 3/8-16 X 2 1/4"
8	NC01-96-0011	1	NYLON NUT 3/8-16

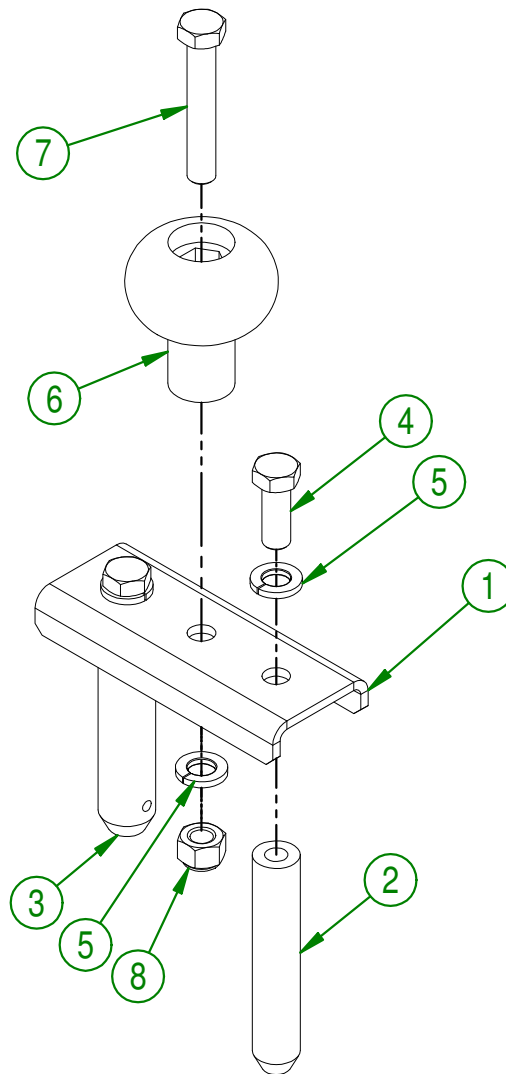

AGRIMETAL		
ASSEMBLY LOCK		
CREATION : 2016-07-06	ASSEMBLY :	32-55-3580
REVISION : 2018-01-10	AUTHOR : S.B.	Page 13 de 15

#	PART #	Qty	TITLE
1	NCI3-30-0237	1	PLASTIC TUBE FOR OPERATOR'S MANUAL
2	32-98-0540	1	OPERATOR MANUEL
3	NC01-04-0003	3	BOLT CARR. GR2 ZINC 1/4-20 X 3/4"
4	NC02-25-0007	3	WASHER ZINC 0.281 = 9/32
5	NC01-96-0009	3	NYLON-INSERT LOCKNUT ZINC 1/4-20

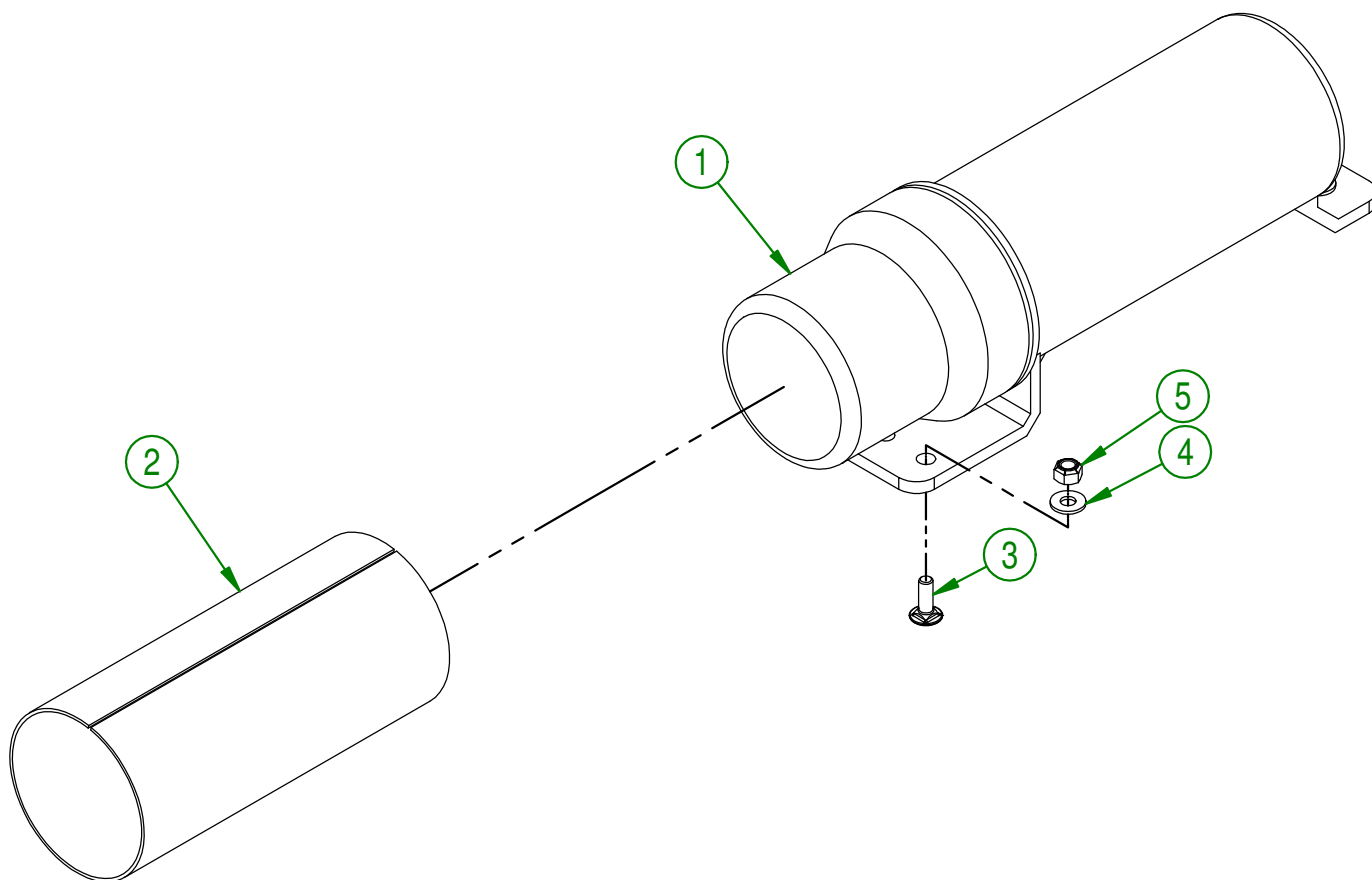

AGRIMETAL	
OPERATOR MANUAL	
CREATION : 10/01/18	ASSEMBLY : 32-57-4115
REVISION : 10/01/18	AUTHOR : F.HÉLIE Page 14 de 15

#	# DE PIÈCE	Qty	TITLE
1	NCI3-33-0110	3	STICKER DANGER
2	NCI3-33-0112	1	STICKER DANGER
3	NCI3-33-0113	1	STICKER WARNING
4	NCI3-33-0163	1	STICKER LOW DECIBEL
5	NCI3-33-0024	6	STICKER GREASE HERE
6	NCI3-33-0120	1	STICKER IMPORTANT
7	NCI3-33-0035	2	STICKER AGRIMETAL
8	NCI3-33-0169	1	STICKER 94 DB
9	NCI3-33-0156	1	STICKER CAUTION
10	NCI3-33-0158	2	STICKER 2500
11	NCI3-33-0018	1	STICKER WARNING
12	NCI3-33-0218	1	STICKER DANGER
13	NCI3-33-0179	1	STICKER IMPORTANT GREASE DRIVE LINE
14	NCI3-33-0298	2	STICKER PULL THIS WAY TO OPEN
15	NCI3-33-0133	1	STICKER DUCT POSITION UP DOWN

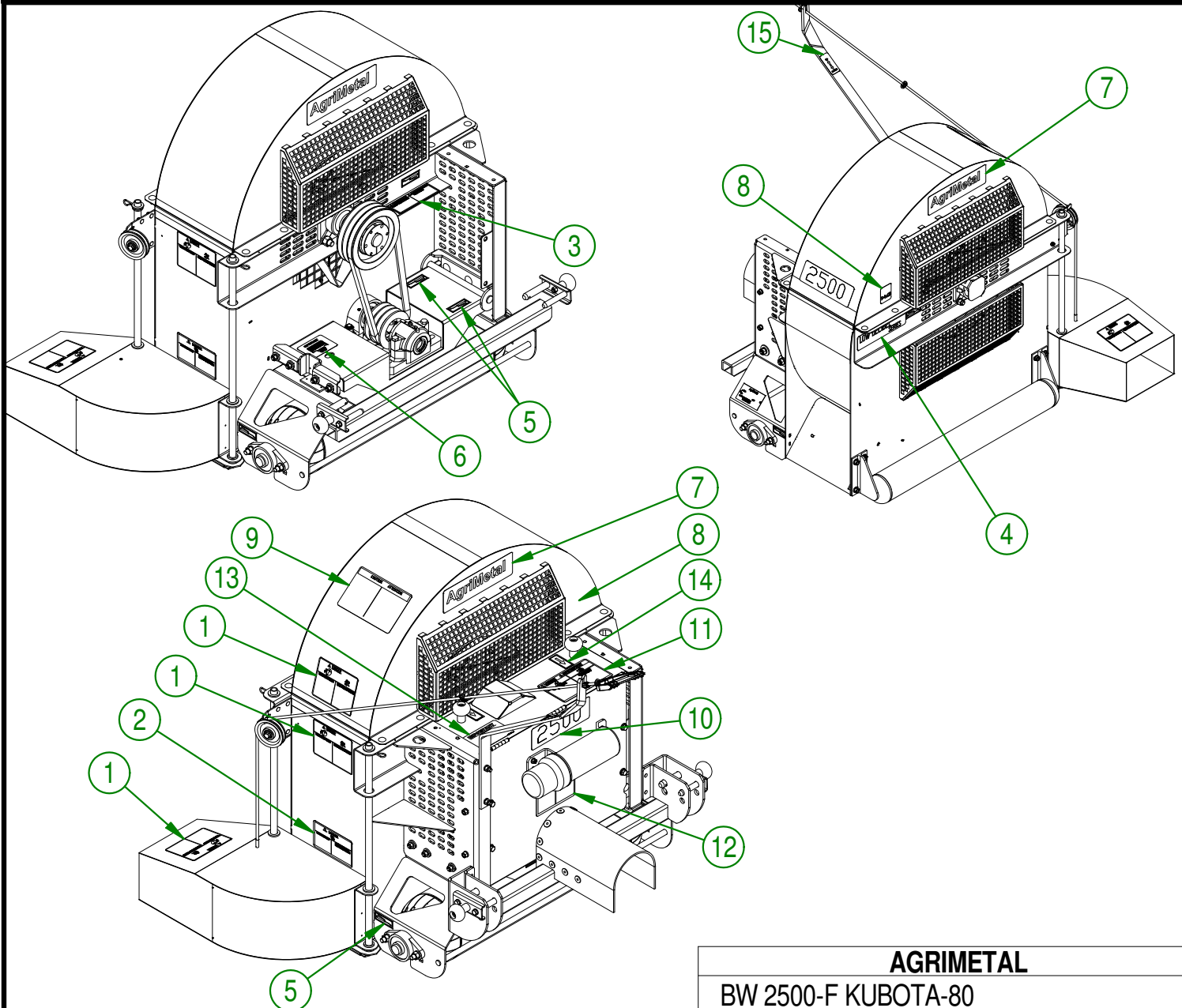

AGRIMETAL		
BW 2500-F KUBOTA-80		
CREATION : 06-07-2016	ASSEMBLY :	32-99-1520
REVISION : 23-10-2018	AUTHOR : S.B.	Page 15 de 15