

AgriMetal

PARTS LIST

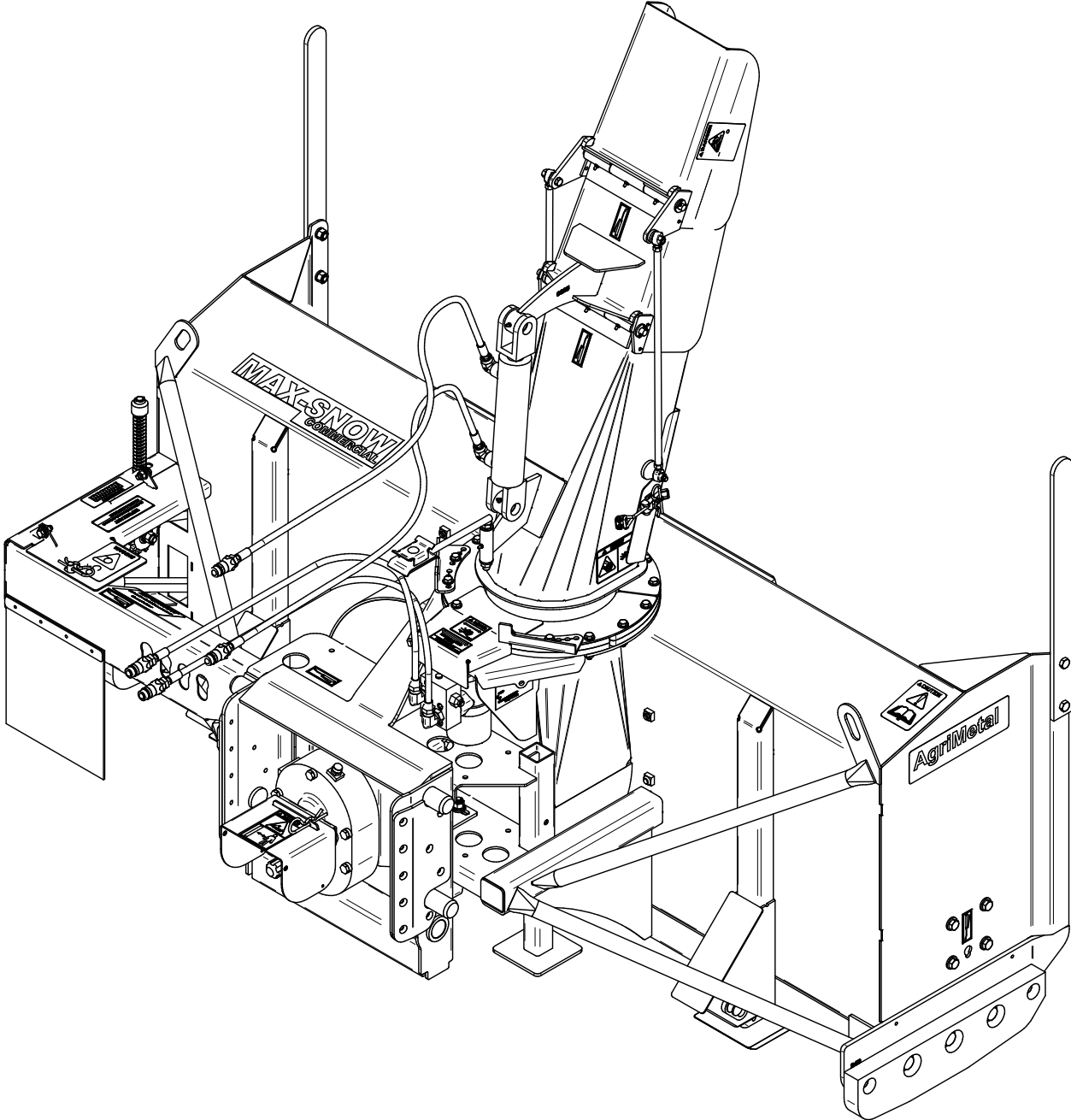

MS 2480-FK

82-57-1200

#	PART #	Qty	TITLE
1	80-50-0085	2	LATERAL SKATE (#450 HARDNESS STEEL)
2	80-50-0055	2	ADJUSTABLE SKATE (STEEL)
3	NC02-48-0586	4	FLAT HEAD SOCKET CAP SCREW 5/8-11 X 1" LG
4	82-57-0060	2	KNIFE (#450 HARDNESS STEEL) GROUP (BOLTS AND NUTS INCLUDED)
5	NC01-25-0481	2	HEX. BOLT GR5 NC 3/4-10 X 5"
6	NC01-96-0017	2	HEX. LOCK NUT NYLO. NC 3/4-10

82-57-0060

#	PART #	Qty	TITLE
7	NC01-09-0029	5	PLOW BOLT GR5 1/2-13 X 1 1/4" LG
8	NC01-93-0014	5	LOCK NUT ZINC 1/2-13

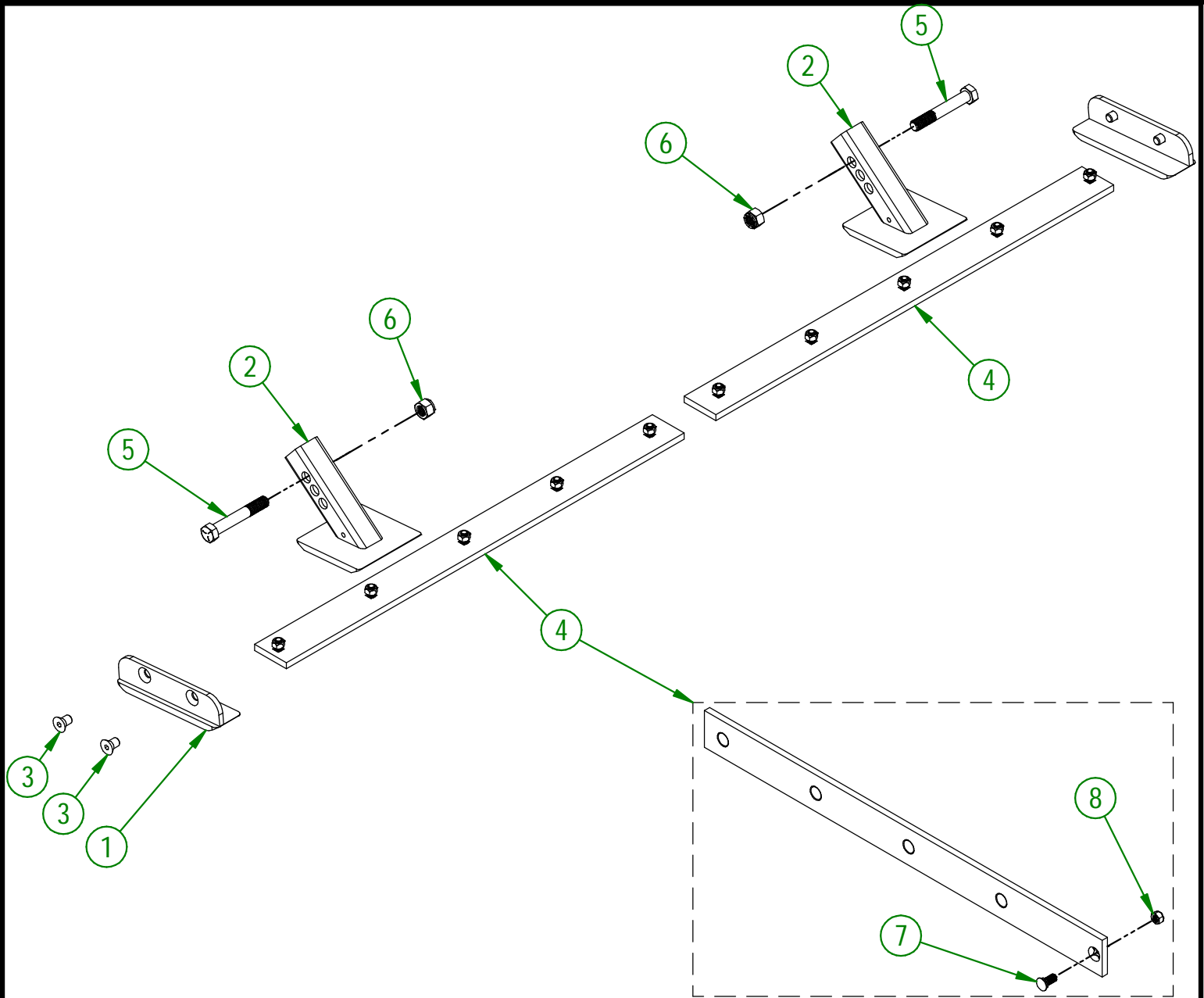

AGRIMETAL

SET OF KNIVES (#450 HARDNESS STEEL)

CREATION : 19/07/16
 REVISION : 21/05/25

ASSEMBLY : **82-57-1200**
 AUTHOR : Dessin2

82-57-1205

#	PART #	Qty	TITLE
1	82-50-1200	2	KNIFE BRACE (TOP)
2	82-42-0105	1	RIGHT KNIFE (UHMW)
3	82-42-0106	1	LEFT KNIFE (UHMW)
4	82-04-0310	2	KNIFE BRACE (UNDER)
5	NC02-48-0548	18	FLAT HEAD SOCKET CAP SCREW STAINLESS 1/2-13 X 2"
6	NC01-93-0014	22	LOCK NUT ZINC 1/2-13
7	82-42-0110	1	LATERAL KNIFE (LEFT)
8	82-42-0111	1	LATERAL KNIFE (RIGHT)
9	80-04-0185	6	WASHER
10	NC01-17-0394	6	HEX. BOLT GR2 ZINC 5/8-11 X 1 1/2"
11	NC02-25-0011	4	WASHER SAE ZINC 17/32 ID
12	NC01-17-0251	2	HEX. BOLT GR2 ZINC 1/2-13 X 2"
13	NC01-17-0250	2	HEX. BOLT GR2 ZINC 1/2-13 X 1 3/4"

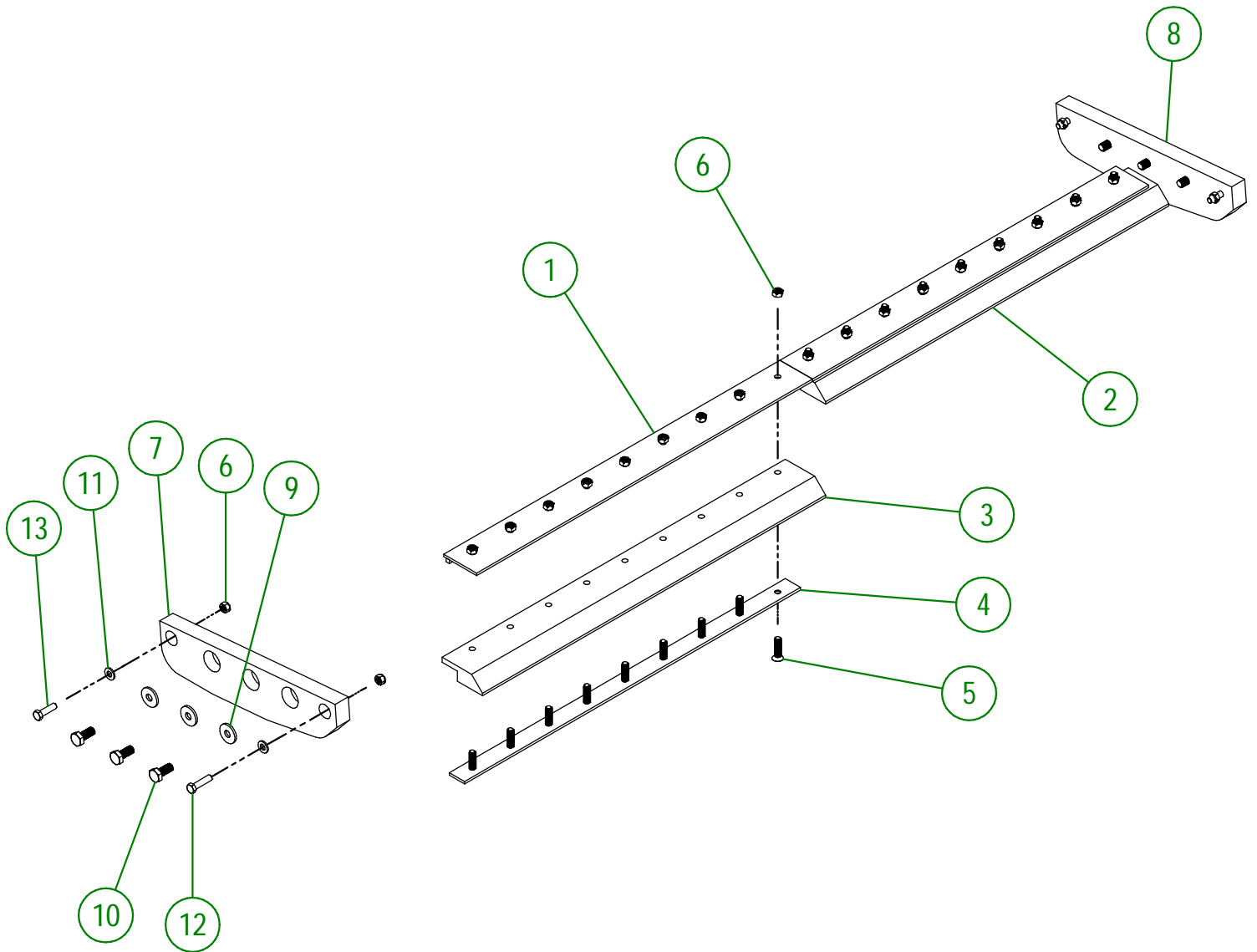

AGRIMETAL	
SET OF KNIVES (UHMW)	
CREATION : 19/07/16	ASSEMBLY : 82-57-1205
REVISION : 27/09/23	AUTHOR : J. HOULE

82-57-1210

#	PART #	Qty	TITLE
1	80-50-0087	2	LATERAL SKATE (STAINLESS STEEL)
2	80-50-0058	2	ADJUSTABLE SKATE (STAINLESS STEEL)
3	NC02-48-0586	4	FLAT HEAD SOCKET CAP SCREW 5/8-11 X 1" LG
4	82-57-0065	2	KNIFE (STAINLESS STEEL) GROUP (BOLTS AND NUTS INCLUDED)
5	NC01-25-0481	2	HEX. BOLT GR5 NC 3/4-10 X 5"
6	NC01-96-0017	2	HEX. LOCK NUT NYLO. NC 3/4-10

82-57-0065

#	PART #	Qty	TITLE
7	NC01-93-0014	9	LOCK NUT ZINC 1/2-13
8	NC02-48-0545	9	FLAT HEAD SOCKET CAP SCREW 1/2"-13 X 1 1/4" (STAINLESS STEEL)

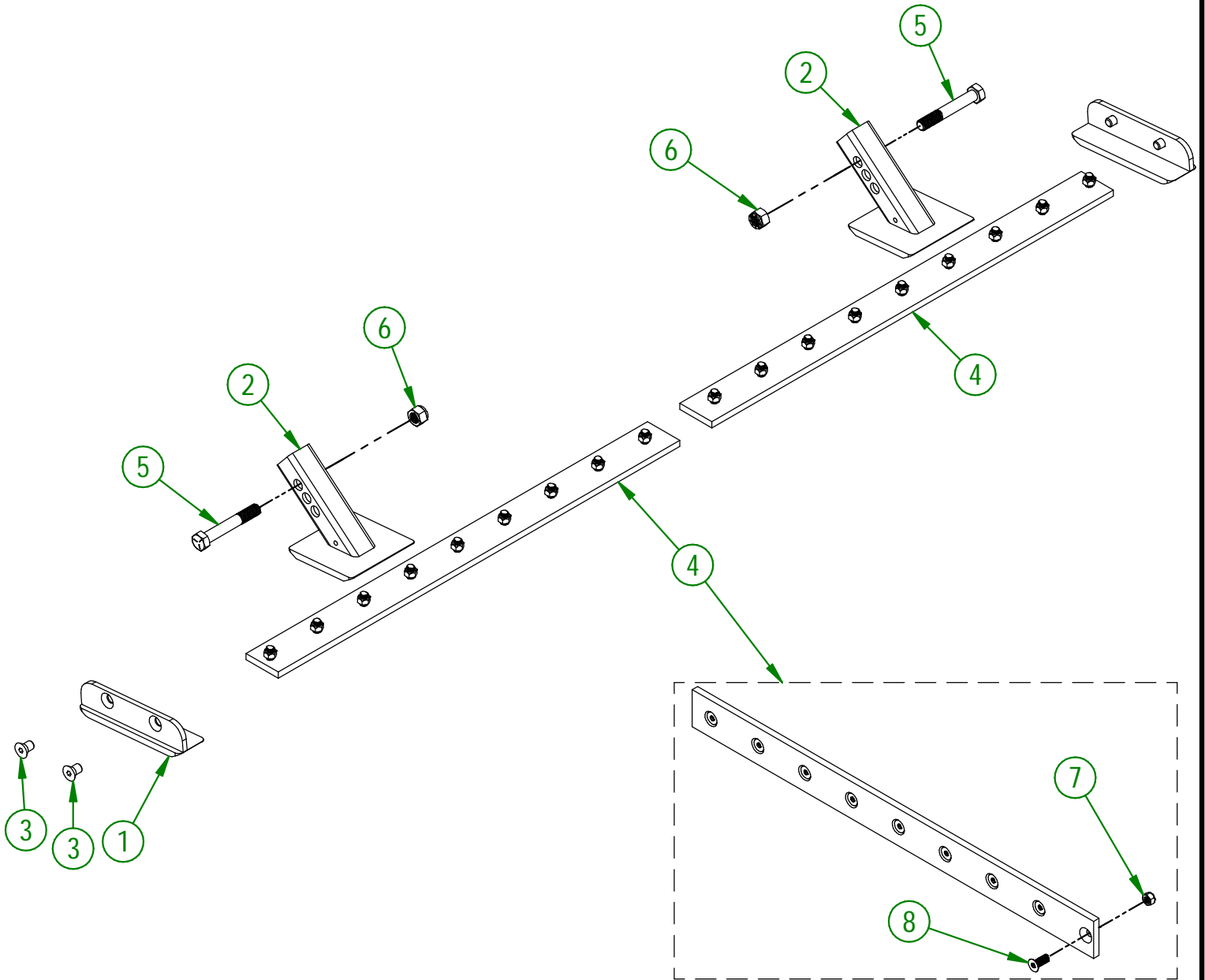

AGRIMETAL	
SET OF KNIVES (STAINLESS STEEL)	
CREATION : 19/07/16	ASSEMBLY : 82-57-1210
REVISION : 21/05/25	AUTHOR : Dessin2

48-57-1235

#	PART #	Qty	TITLE
1	48-05-2105	2	LATERAL CUTTER BLADES
2	NC01-25-0248	4	HEX. BOLT GR5 ZINC 1/2-13 X 1 1/4"
3	NC02-32-0014	4	LOCK WASHER ZINC 1/2"
4	NC02-07-0020	4	HEX. NUT ZINC 1/2-13

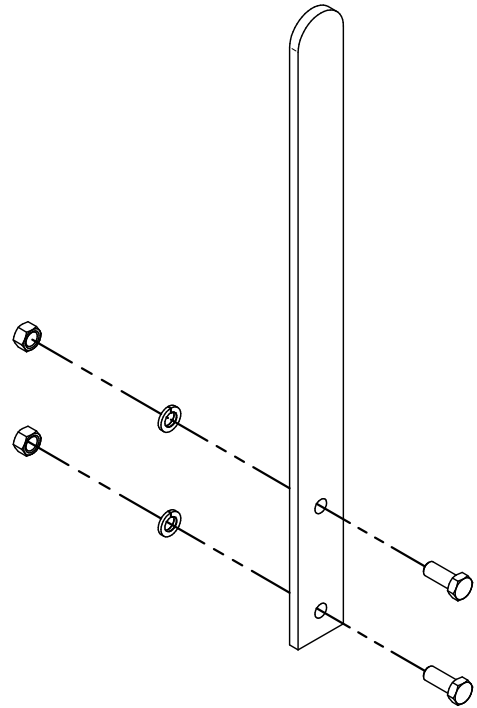
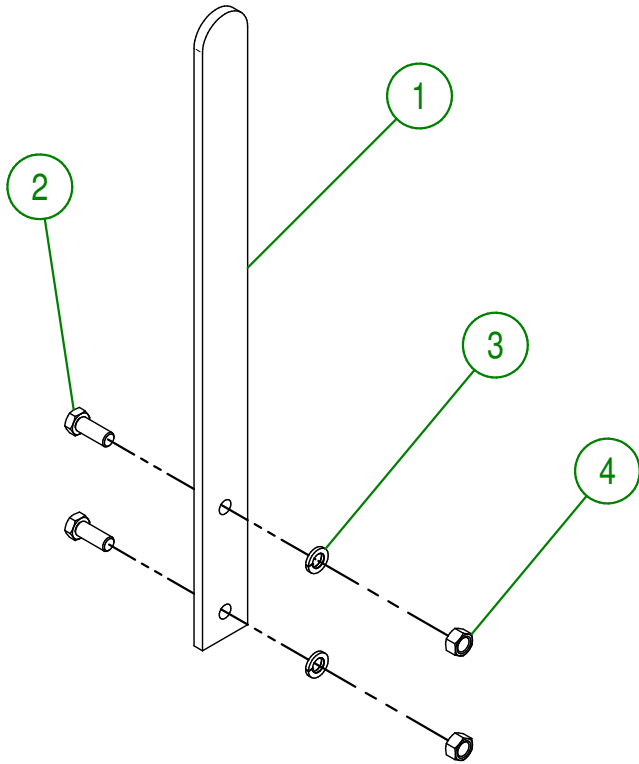

AGRIMETAL	
LATERAL CUTTER BLADES	
CREATION : 24/11/17	ASSEMBLY : 48-57-1235
REVISION : 22/10/18	AUTHOR : J. Houle

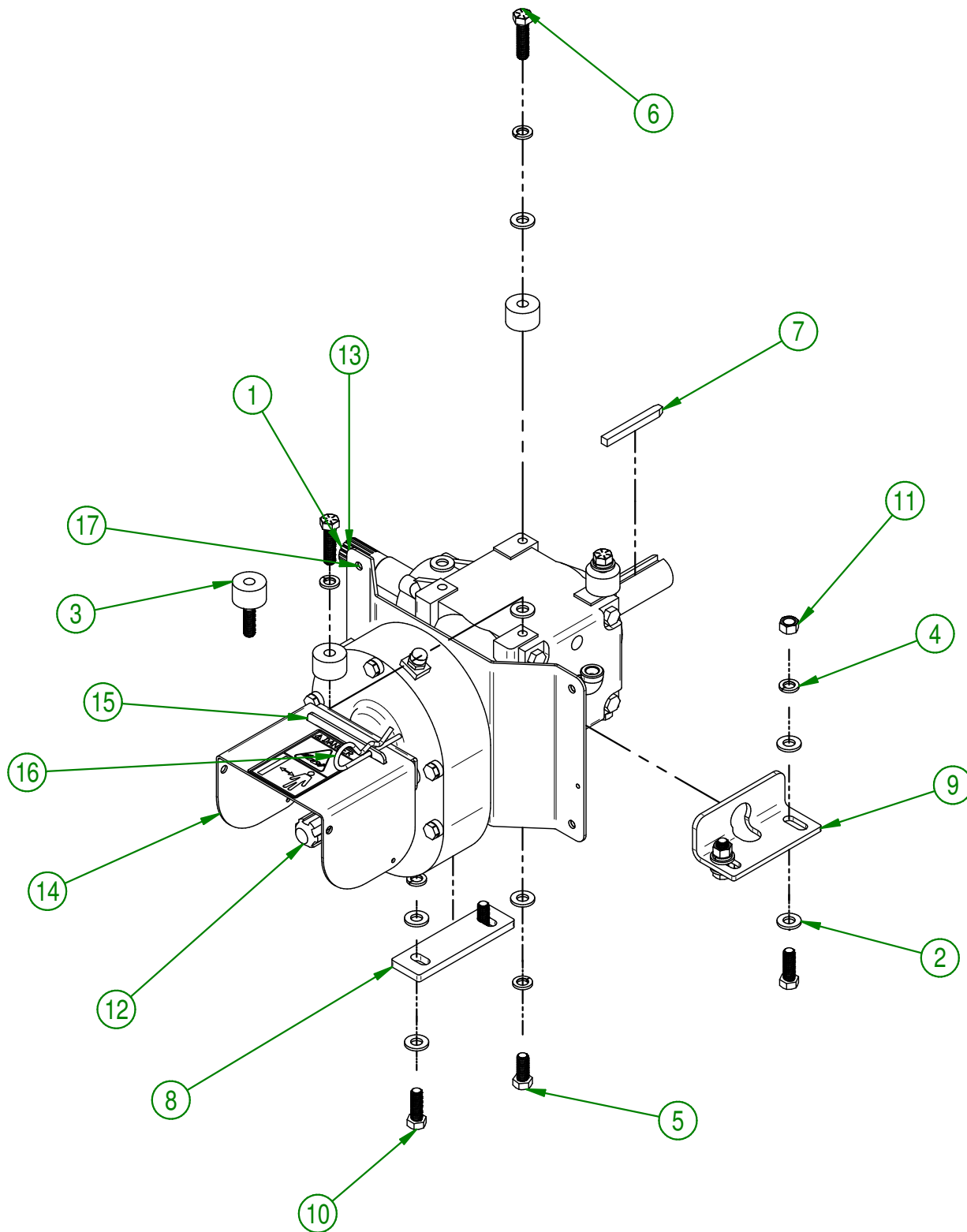

AGRIMETAL	
GEARBOX GROUPING	
CREATION : 07/01/21	ASSEMBLY : 82-57-5010
REVISION : 07/01/21	AUTHOR : G. HUBERDEAU

82-57-5010

#	PART #	Qty	TITLE
1	80-55-0010	1	GEARBOX
2	NC02-25-0011	16	WASHER SAE ZINC 17/32 ID
3	80-21-0010	4	TRANSMISSION BUSHING
4	NC02-32-0014	12	LOCK WASHER ZINC 1/2"
5	NC01-33-0248	4	HEX. BOLT .GR8 NC ZINC 1/2-13 X 1 1/4"
6	NC01-33-0251	4	HEX. BOLT GR8 NC ZINC 1/2-13 X 2"
7	80-41-0900	1	IMPELLER KEY
8	80-04-0480	1	GEARBOX BRACE
9	80-04-0485	1	GEARBOX BRACE
10	NC01-33-0249	4	CAP SCREW GR8 NC ZINC 1/2-13 X 1 1/2" LG
11	NC02-07-0020	4	HEX. NUT ZINC 1/2-13
12	NC14-10-0167	1	GEARBOX T27D
13	82-01-0030	1	
14	82-57-5035	1	PTO GUARD
15	80-01-0170	1	PTO GUARD SUPPORT
16	NC01-63-0027	1	HAIRPIN COTTER
17	21-01-0950	4	FLAT WASHER IOGA 1.005" DIA X 25/64"
18*	NC02-32-0012	5	LOCK WASHER ZINC 3/8"
19*	NC01-45-0218	5	

AGRIMETAL**GEARBOX GROUPING**

CREATION : 07/01/21
 REVISION : 07/01/21

ASSEMBLY : **82-57-5010**
 AUTHOR : G. HUBERDEAU

82-57-5006

#	PART #	Qty	TITLE
1	82-57-5001	1	FRAME AND STICKER
2	NC13-15-0315	1	SNOW GUARD
3	82-01-0970	1	SNOW GUARD BRACE
4	NC01-78-0016	4	ALUMINIUM BLIND POP RIVET STEEL MANDREL 0.187 X 0.690
5	NC13-15-0320	1	RUBBER
6	80-57-0060	1	RUBBER REINFORCEMENT
7	NC01-17-0060	5	HEX. BOLT GR2 ZINC 5/16-18 X 1"
8	NC01-93-0010	5	LOCK NUT ZINC 5/16-18
9	NC01-63-0026	1	COTTER PIN ZC 5/32" X 3"
10	82-01-0110	1	SPIRAL DRIVE TRAIN GUARD
11	NC02-32-0011	2	LOCK WASHER ZINC 5/16"
12	NC01-25-0058	2	HEX BOLT GR5 ZINC PLATED 5/16-18 X 3/4"

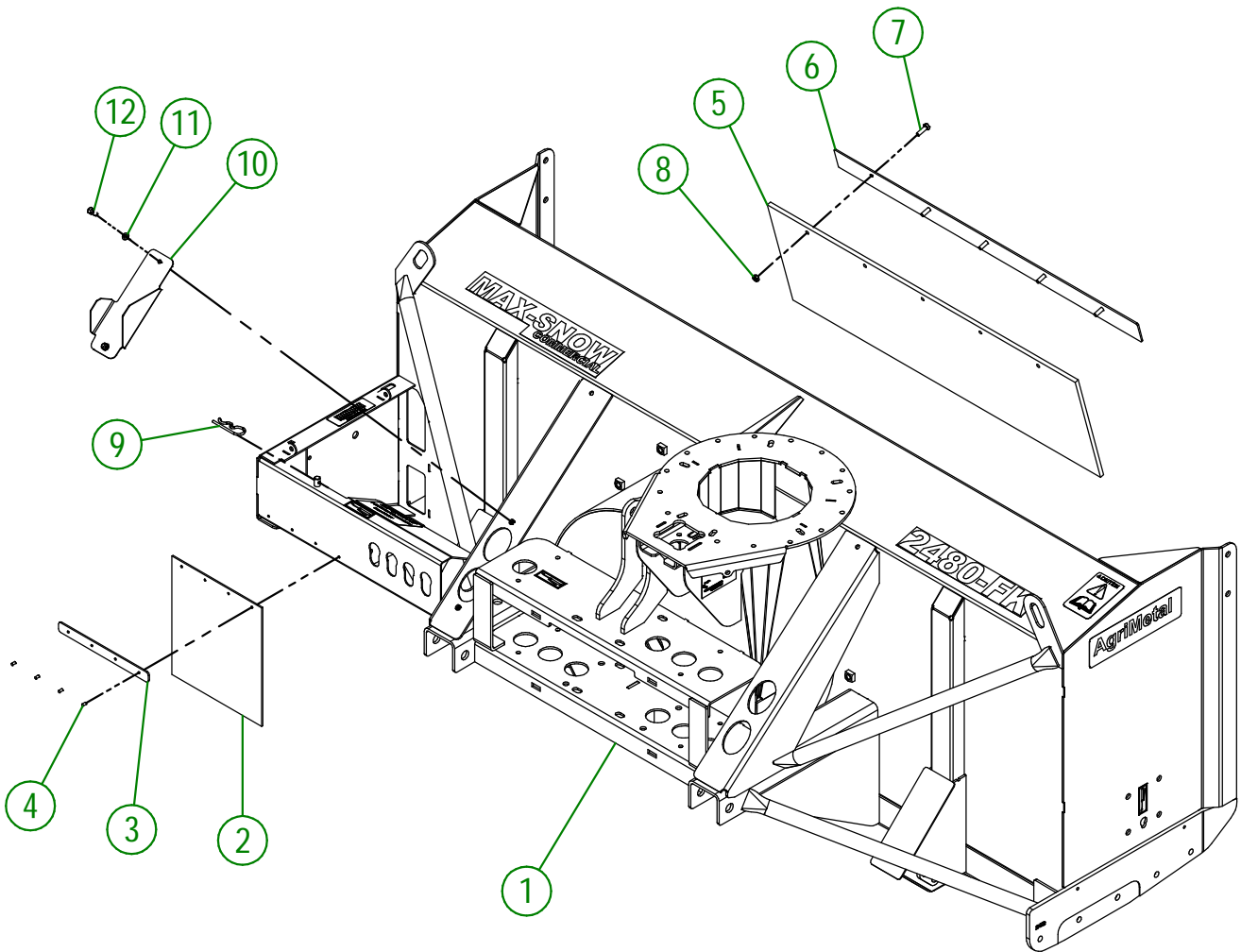

AGRIMETAL
FRAME GROUP

CREATION : 20/03/24
REVISION : 21/05/25

ASSEMBLY : **82-57-5006**
AUTHOR : J. Houle

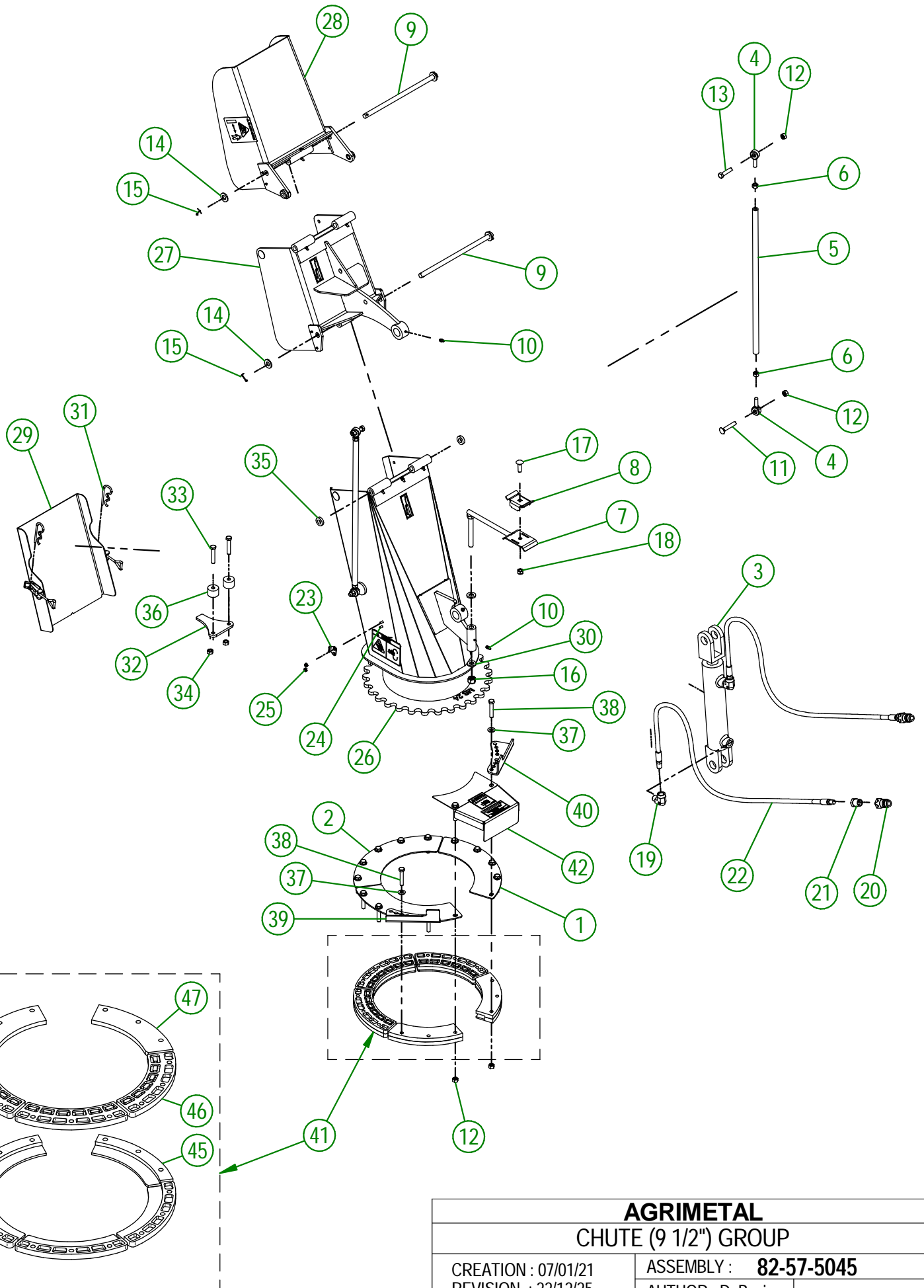

AGRIMETAL
CHUTE (9 1/2") GROUP

CREATION : 07/01/21
 REVISION : 22/12/25

ASSEMBLY : **82-57-5045**
 AUTHOR : D. Bevins

82-57-5045

#	PART #	QTY	TITLE
1	82-01-0965	2	BRACE
2	82-01-0955	1	BRACE
3	NC13-45-0404	1	HYDRAULIC CYLINDER 6"
4	NC01-67-0304	4	ROD END 3/8-24
5	48-13-0600	2	CHUTE ROD (DOUBLE)
6	NC02-10-0018	4	NUT 3/8-24
7	82-50-5030	1	HYDRAULIC HOSE SUPPORT
8	48-01-7530	1	HYDRAULIC HOSE SUPPORT
9	82-20-0250	2	PIVOT
10	NC01-69-0785	9	STRAIGHT GREASE FITTING 1/4-28
11	NC01-07-0113	2	CARR. BOLT GR5 ZINC 3/8-16 X 2" LG
12	NC01-93-0011	19	LOCK NUT 3/8-16
13	NC01-25-0116	2	HEX. BOLT GR5 ZINC 3/8-16 X 1 1/2"
14	NC02-25-0011	4	WASHER SAE ZINC 17/32 ID
15	NC01-69-0139	4	COTTER PIN ZINC 1/8" X 3/4"
16	NC01-96-0014	1	NYLON-INSERT LOCKNUT ZINC 1/2-13
17	NC01-04-0110	1	CARR. BOLT GR2 ZINC 3/8-16 X 1 1/4"
18	NC01-96-0011	1	NYLON NUT 3/8-16
19	NC13-45-0038	2	ELBOW 90 3/8 FEM. NPT X 3/8 MALE NPT
20	NC13-45-0369	2	QUICK COUPLER 1/2-14 NPTF
21	NC13-45-0153	2	HEX. REDUCER 1/4 NPT X 1/2 NPT
22	NC17-02-0329	2	HYDRAULIC HOSE (87" LG)
23	NC01-63-0052	2	ADJUSTABLE LATCH (STRIKE)
24	NC02-40-0080	4	MACHINE SCREWS SQUARE SOCKET #10-24 X 1/2" LG
25	NC01-96-0006	4	NYLON NUT ZINC 3/16
26	84-57-0300	1	CHUTE (BOTTOM SECTION)
27	82-57-0311	1	CHUTE (MIDDLE SECTION)
28	82-57-0321	1	CHUTE (TOP SECTION)
29	82-57-0352	1	CHUTE DOOR
30	NC02-25-0011	2	WASHER SAE ZINC 17/32 ID
31	NC01-63-0026	2	COTTER PIN ZC 5/32" X 3"
32	84-04-0195	1	STOPPER
33	NC01-37-0118	2	HEX. BOLT GR8 ZINC 3/8-24 X 2"
34	NC01-94-0011	2	LOCK NUT 3/8-24
35	NC13-15-0334	2	PIVOT WASHER
36	81-21-0040	2	ADJUSTABLE STOPPER SPACER
37	NC02-26-1525	15	WASHER INOX .406" D.I. X .815" D.E.
38	NC01-17-0118	15	HEX. BOLT GR2 ZINC 3/8-16 X 2"
39	84-04-0180	1	ADJUSTABLE STOPPER
40	84-04-0183	1	ADJUSTABLE STOPPER
41	84-57-1325	1	CHUTE GUIDE GROUP
42	84-57-0500	1	SPROCKET GUARD GROUP "STICKER INCLUDED"

84-57-1325

#	PART #	QTY	TITLE
43	46-42-0107	1	CHUTE GUIDE (UNDER)
44	NC17-46-0030	3	CHUTE GUIDE (UNDER)
45	46-42-0106	1	CHUTE GUIDE (UNDER)
46	NC17-46-0029	3	CHUTE GUIDE (TOP)
47	46-42-0101	1	CHUTE GUIDE (TOP)
48	46-42-0102	1	CHUTE GUIDE (TOP)

#	PART #	Qty	TITLE
1	NC14-45-0156	1	HYDRAULIC MOTOR
2	48-50-1025	1	HYDRAULIC ENGINE SPROCKET
3	NC02-32-0012	4	LOCK WASHER ZINC 3/8"
4	NC01-33-0113	4	HEX.BOLT GR8 ZINC 3/8-16 X 3/4"
5	NC13-45-0367	2	45°-7/8-14 MALE O RING X 1/2 FEM.TOUR.NPT PT
6	NC13-45-0369	2	QUICK COUPLER 1/2-14 NPTF
7	NC17-02-0328	2	HYDRAULIC HOSE (63" LG)
8	80-13-0100	2	HYDRAULIC RESTRICTOR
9	NC13-45-0378	2	HYDRAULIC RESTRICTOR BUSHING
10	80-45-0000	2	HEX. REDUCER 1/4 NPT X 1/2 NPT
11	NC02-32-0010	1	LOCK WASHER ZINC 1/4"
12	NC01-33-0005	1	HEX. BOLT GR8 ZINC 1/4-20 X 7/8"
13	NC17-46-0031	1	HYDRAULIC MOTOR BUSHING
14	NC02-22-0009	1	WASHER
15	NC02-44-0103	2	SET SCREW 5/16-18 X 3/8"

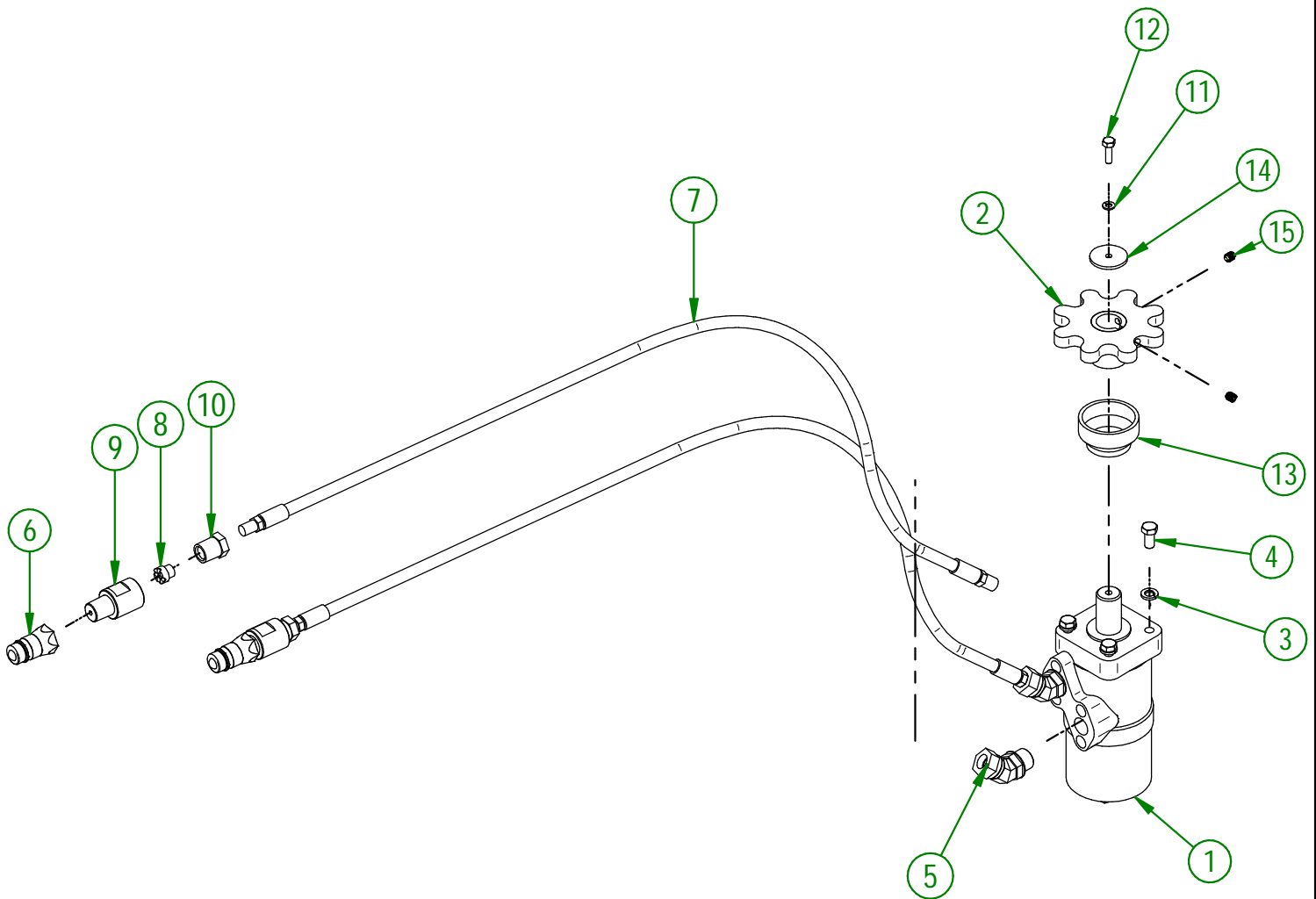

AGRIMETAL
HYDRAULIC MOTOR GROUP

CREATION : 07/01/21
 REVISION : 11/12/25

ASSEMBLY : **82-57-5015**
 AUTHOR : G.HUBERDEAU

82-57-5025

#	PART #	Qty	TITLE
1	82-50-5005	1	IMPELLER
2	80-04-0185	1	WASHER
3	NC01-25-0395	1	HEX. BOLT GR5 ZINC 5/8-11 X 1 3/4" LG
4	NC02-32-0016	1	LOCK WASHER ZINC 5/8"
5	82-50-5025	1	SHEAR PLATE
6	NC01-17-0063	1	CAP SCREW GR2 NC ZINC 5/16-18 X 1 3/4"
7	NC01-96-0010	1	NYLON NUT HEX. ZINC 5/16-18

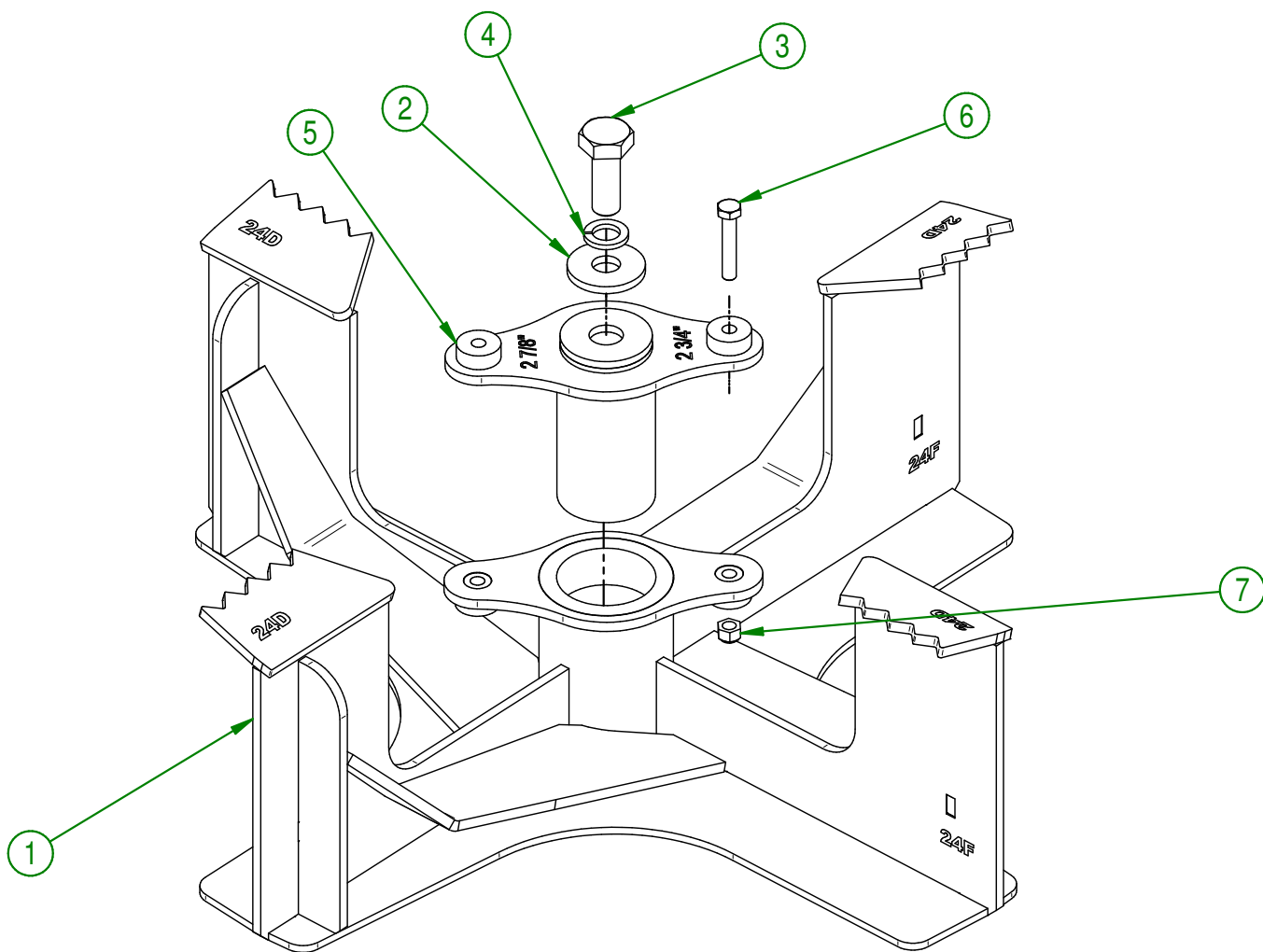

AGRIMETAL	
IMPELLER GROUP	
CREATION : 07/01/21	ASSEMBLY : 82-57-5025
REVISION : 07/01/21	AUTHOR : G.HUBERDEAU

82-57-5040

#	PART #	Qty	TITLE
1	82-50-5020	1	LEFT SNOW GUARD
2	82-50-0113	1	RIGHT SNOW GUARD
3	NC02-32-0014	6	LOCK WASHER ZINC 1/2"
4	NC01-25-0247	6	HEX. BOLT GR5 ZINC 1/2-13 X 1" LG

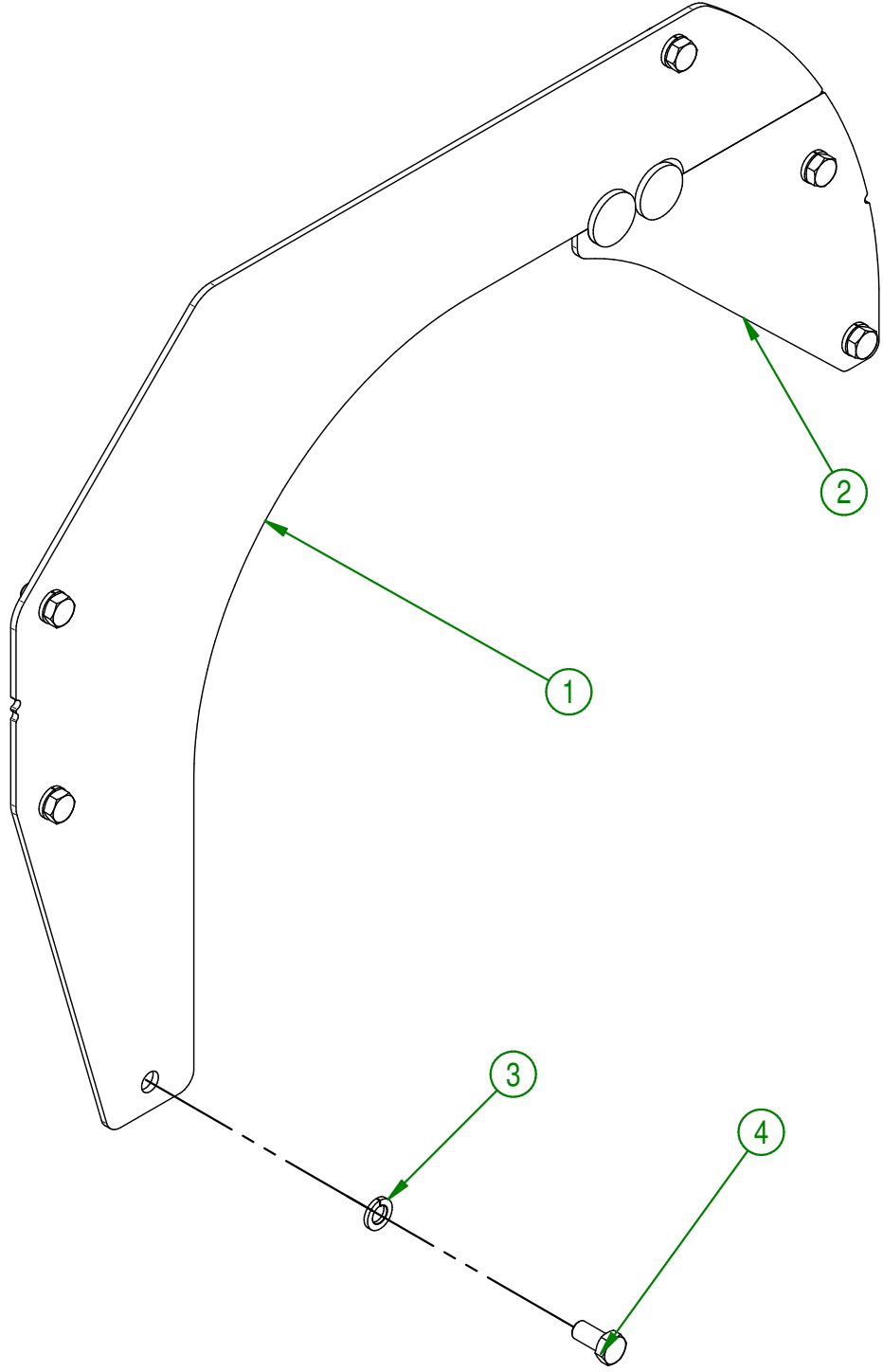

AGRIMETAL	
SNOW GUARD GROUP	
CREATION : 07/01/21	ASSEMBLY : 82-57-5040
REVISION : 07/01/21	AUTHOR : G.HUBERDEAU

#	PART #	Qty	TITLE
1	NC14-75-0160	2	FLANGE BEARING UCF207-20 1/4" ID
2	82-50-1080	1	SPIRAL
3	NC02-25-0011	8	WASHER SAE ZINC 17/32 ID
4	NC01-17-0250	8	HEX. BOLT GR2 ZINC 1/2-13 X 1 3/4"
5	NC02-32-0014	8	LOCK WASHER ZINC 1/2"
6	NC02-07-0020	8	HEX. NUT ZINC 1/2-13
8	NC14-55-0294	1	60A32H SPROCKET
9	NC01-37-0115	4	HEX. BOLT GR8 ZINC 3/8-24 X 1 1/4"
10	NC01-94-0011	4	LOCK NUT ZINC 3/8-24
11	82-51-0086	1	SHAFT OF THE SPIRAL
12	82-51-0091	1	SHAFT OF THE SPIRAL (SPROCKET)

REBUILT KIT

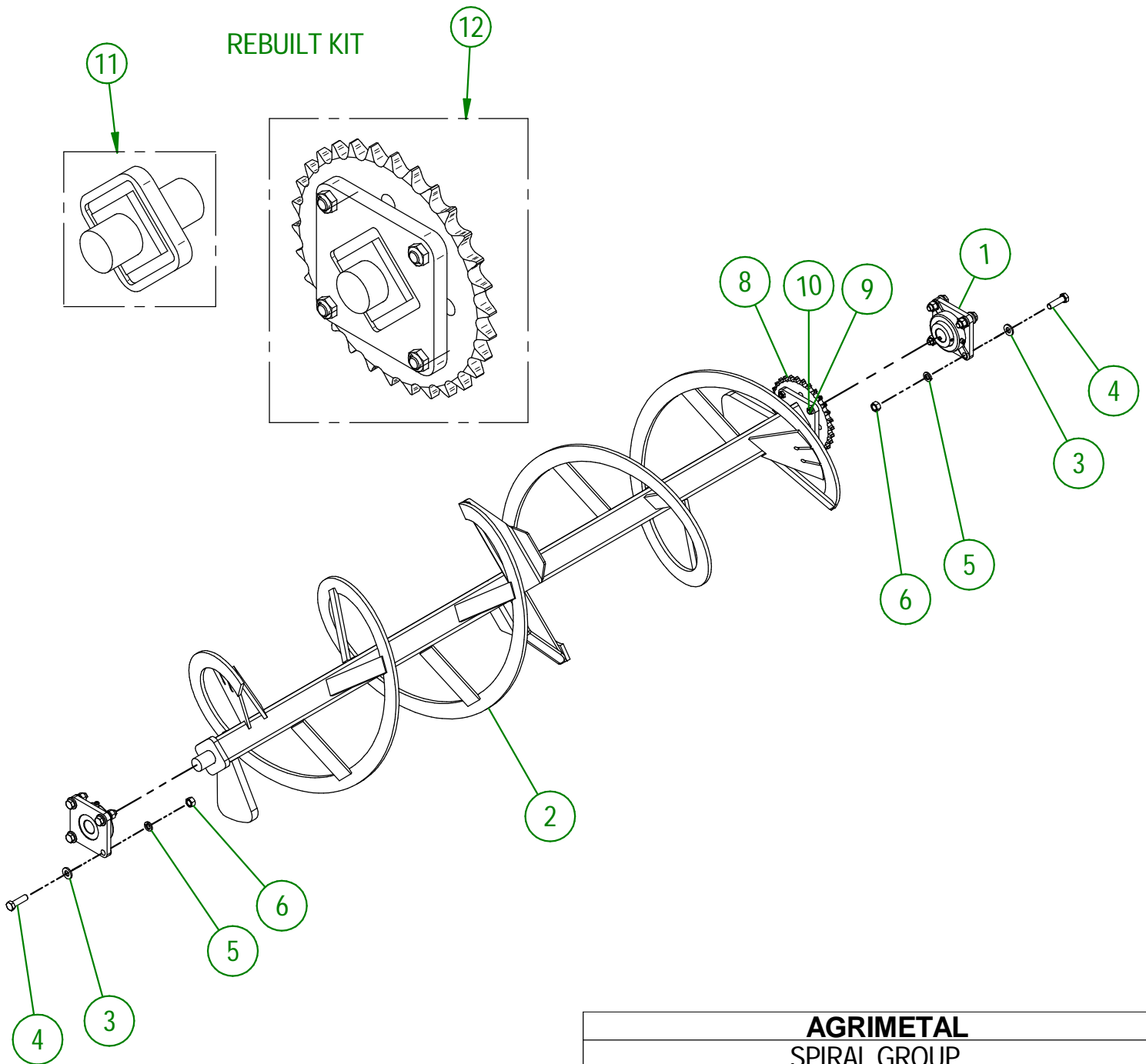

AGRIMETAL
SPIRAL GROUP

CREATION : 20/07/16
REVISION : 09/12/25

ASSEMBLY : **82-57-2915**
AUTHOR : J. HOULE

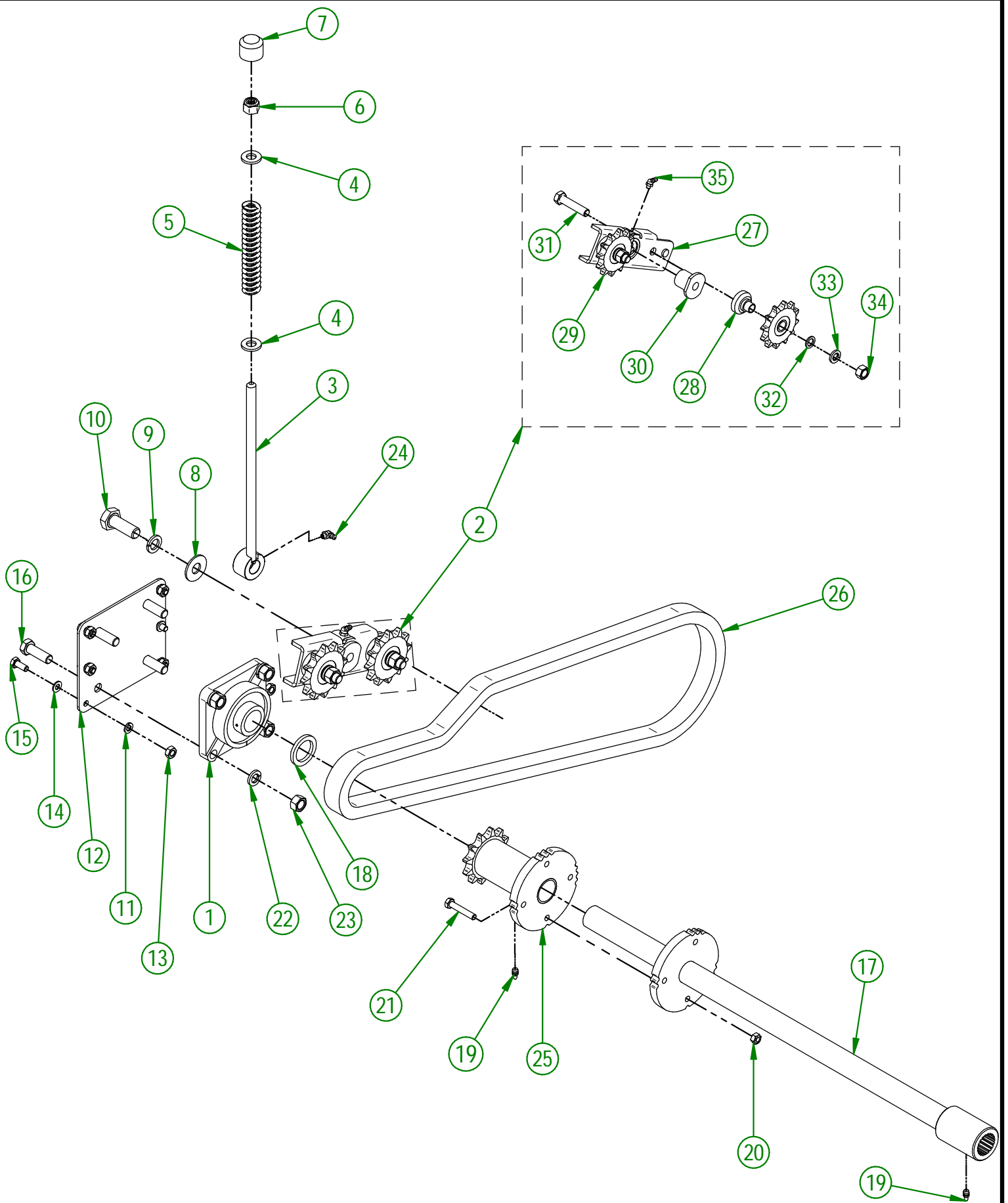

AGRIMETAL	
DRIVE TRAIN SPIRAL GROUP	
CREATION : 07/01/21	ASSEMBLY : 82-57-5020
REVISION : 07/09/23	AUTHOR : G.HUBERDEAU

82-57-5020

#	PART #	Qty	TITLE
1	NC14-75-0024	1	FLANGE BEARING 4 HOLES UCF207-20 1 1/4" DIA.
2	80-55-0025	1	CHAIN TENSIONER GROUP
3	80-50-0040	1	THREADED ROD
4	NC02-25-0011	2	WASHER SAE ZINC 17/32 ID
5	NC13-86-0053	1	BLUE SPRING 1/2" ID X 1" OD X 6" LG
6	NC01-96-0014	1	NYLON-INSERT LOCKNUT ZINC 1/2-13
7	80-42-0110	1	THREADED ROD CAP
8	NC02-22-0013	1	WASHER ZINC 5/8 ID X 1 1/2 OD
9	NC02-32-0016	1	LOCK WASHER ZINC 5/8"
10	NC01-17-0395	1	HEX. BOLT GR2 ZINC 5/8-11 X 1 3/4"
11	NC02-32-0011	6	LOCK WASHER ZINC 5/16"
12	82-01-0005	1	BEARING SUPPORT
13	NC02-07-0017	6	HEX. NUT 5/16-18
14	NC02-22-0008	6	WASHER ZINC 5/16"
15	NC01-17-0058	6	HEX. BOLT GR2 ZINC 5/16-18 X 3/4" LG
16	NC01-17-0249	4	HEX. BOLT GR2 ZINC 1/2-13 X 1 1/2"
17	82-50-1066	1	SPIRAL DRIVE TRAIN
18	82-21-0005	1	SPIRAL DRIVE TRAIN BUSHING
19	NC01-69-0785	2	STRAIGHT GREASE FITTING 1/4-28
20	NC01-93-0010	1	LOCK NUT ZINC 5/16-18
21	NC01-17-0063	1	CAP SCREW GR2 NC ZINC 5/16-18 X 1 3/4"
22	NC02-32-0014	4	LOCK WASHER ZINC 1/2"
23	NC02-07-0020	4	HEX. NUT ZINC 1/2-13
24	NC01-69-0787	1	GREASE FITTING STRAIGHT 1/4-28 X 90
25	NC14-55-0327	1	60B12H SPROCKET
26	82-37-5000	1	CHAIN #60 X 63" LG + HALF LINK CHAIN

80-55-0025

#	PART #	Qty	TITLE
27	80-50-0045	1	CHAIN TENSIONER
28	80-21-0020	2	CHAIN TENSIONER BUSHING (SPROCKET)
29	NC14-55-0295	2	SPROCKET 60A12H
30	80-13-2400	1	CHAIN TENSIONER BUSHING
31	NC01-29-0252	2	HEX. BOLT GR2 ZINC 1/2-20 X 2 1/4" LG
32	NC02-26-1100	2	WASHER SAE ZINC 17/32 ID X 13/16" OD
33	NC02-32-0014	2	LOCK WASHER ZINC 1/2"
34	NC02-10-0020	2	HEX. NUT ZINC 1/2-20
35	NC01-69-0786	1	GREASE FITTING 1/4-28 X 45

AGRIMETAL**DRIVE TRAIN SPIRAL GROUP**

CREATION : 07/01/21

REVISION : 07/09/23

ASSEMBLY : **82-57-5020**

AUTHOR : G.HUBERDEAU

82-57-5030

#	PART #	Qty	TITLE
1	82-50-5015	1	CHAIN GUARD
2	NC01-04-0107	4	CARR. BOLT GR2 ZINC 3/8-16 X 3/4"
3	NC02-14-0019	4	FLANGE NUT HEX. NC 3/8-16 GR. B

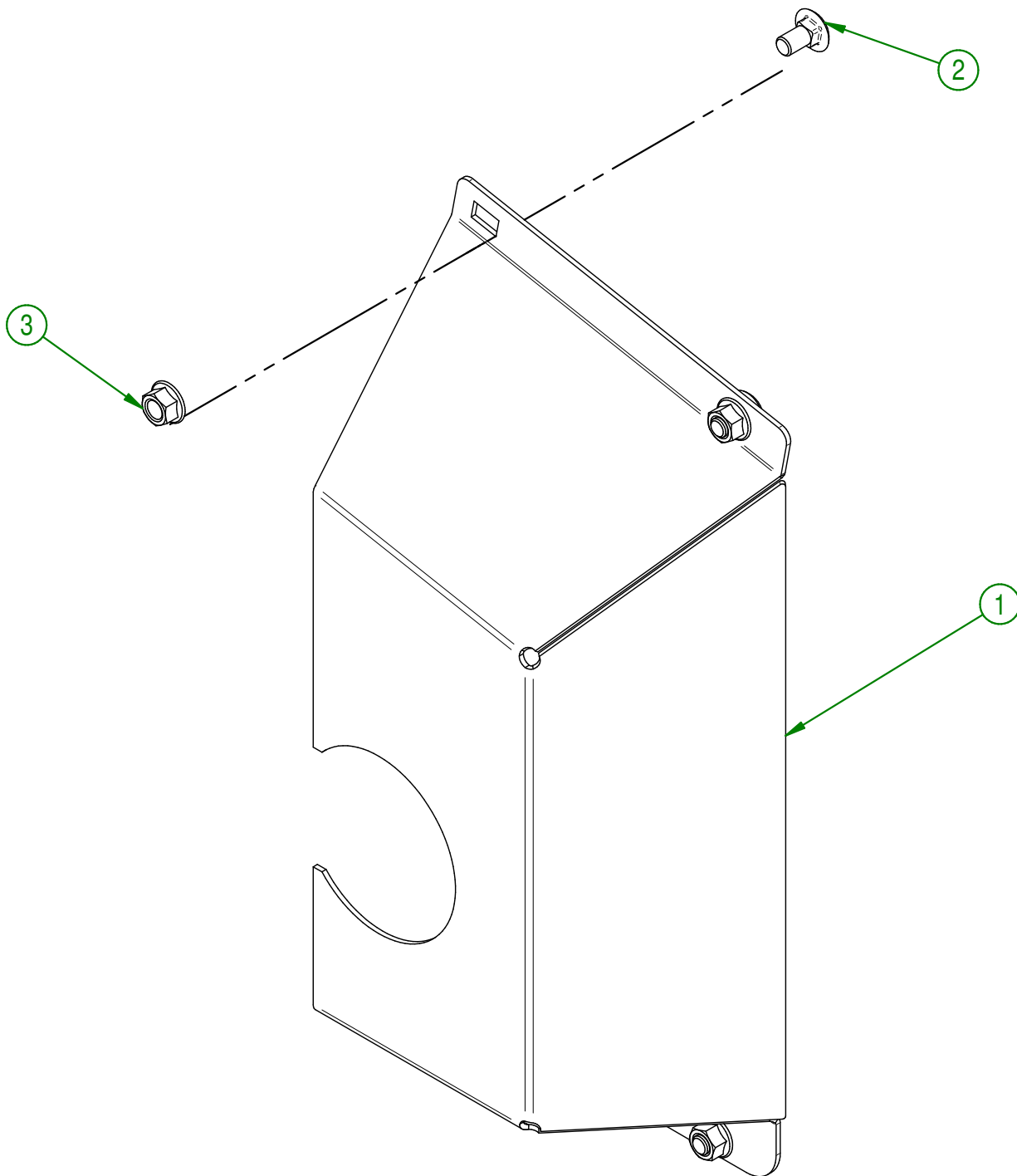

AGRIMETAL	
SPIRAL CHAIN GUARD GROUP	
CREATION : 07/01/21	ASSEMBLY : 82-57-5030
REVISION : 07/01/21	AUTHOR : G.HUBERDEAU

#	PART #	Qty	TITLE
1	NC02-26-1525	4	WASHER INOX .406" D.I. X .815" D.E.
2	NC01-17-0114	2	HEX. BOLT GR2 ZINC 3/8-16 X 1"
3	NC01-96-0011	2	NYLON NUT 3/8-16
4	82-57-0036	1	CHAIN GUARD

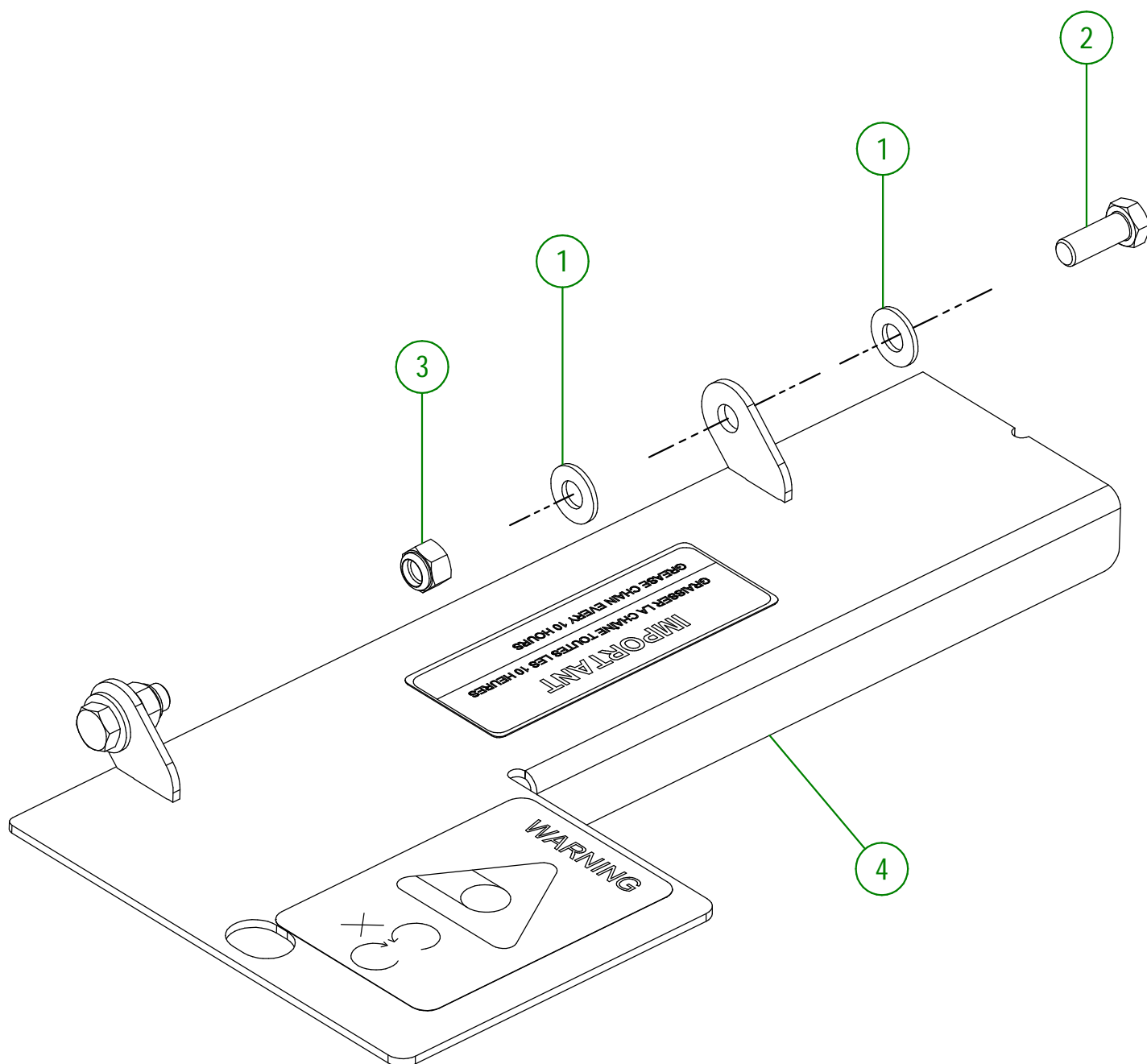

AGRIMETAL	
CHAIN GUARD GROUP	
CREATION : 20/07/16	ASSEMBLY : 82-57-1945
REVISION : 22/12/25	AUTHOR : J. HOULE

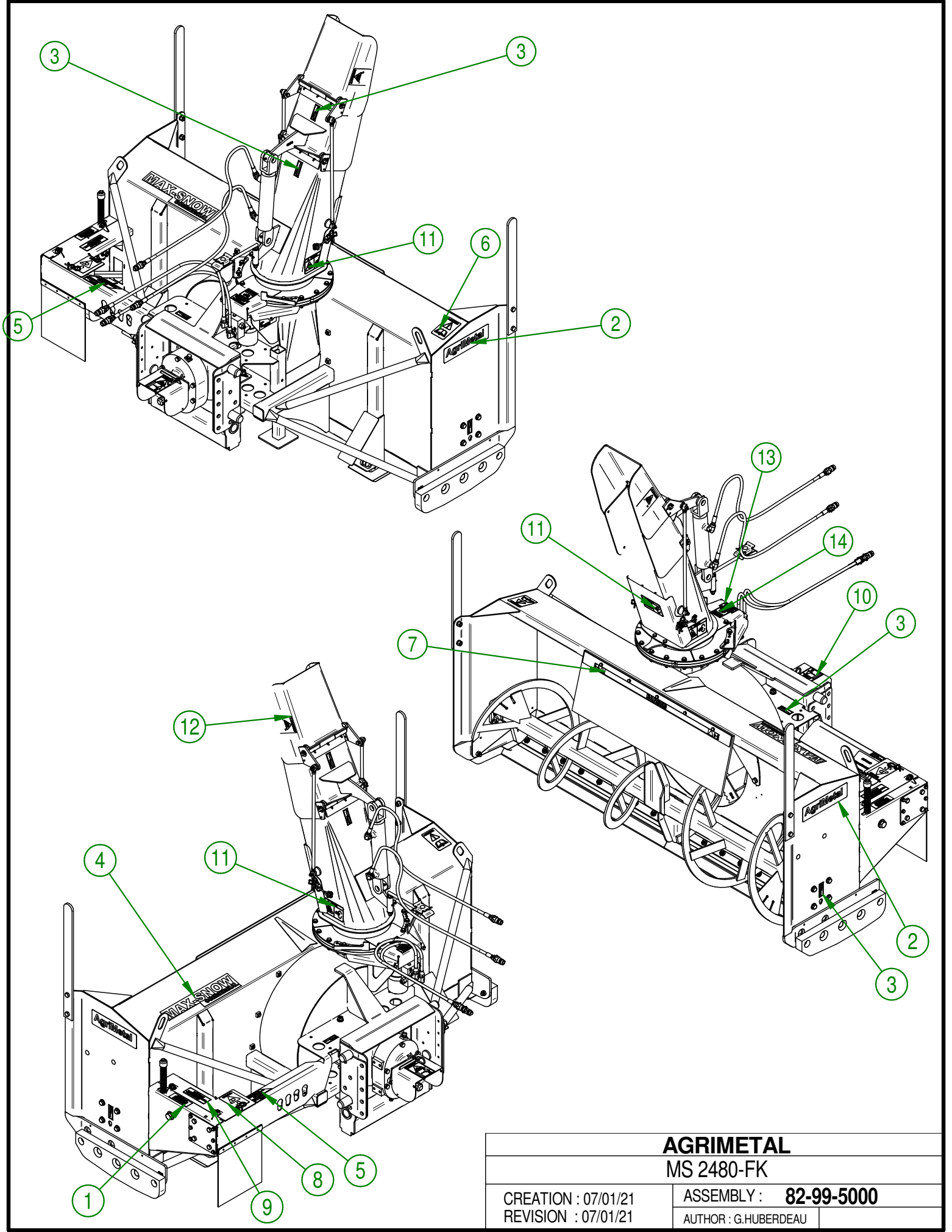

AGRIMETAL

MS 2480-FK

CREATION : 07/01/21
 REVISION : 07/01/21

ASSEMBLY : **82-99-5000**

AUTHOR : G.HUBERDEAU

82-99-5000

#	PART #	Qty	TITLE
1	NC13-33-0104	1	STICKER IMPORTANT 4 INCHES 100 MM
2	NC13-33-0035	2	STICKER AGRIMETAL
3	NC13-33-0024	4	STICKER GREASE HERE
4	NC13-33-0241	1	STICKER MAX-SNOW COMMERCIAL
5	NC13-33-0280	1	STICKER SHEAR BOLT
6	NC13-33-0183	1	STICKER CAUTION OPERATION MANUAL
7	NC13-33-0274	1	STICKER DANGER
8	NC13-33-0283	1	STICKER DANGER (PERSON AND CHAIN DRIVE)
9	NC13-33-0343	1	GREASE CHAIN EVERY 10 HOURS STICKER
10	NC13-33-0187	1	STICKER DANGER (PTO AND PERSON)
11	NC13-33-0249	3	STICKER DANGER
12	NC13-33-0192	1	STICKER (PROJECTION RISK)
13	NC13-33-0327	1	STICKER END ROTATION ADJUSTMENT
14	NC13-33-0326	1	STICKER DANGER (HAND)

AGRIMETAL

MS 2480-FK

CREATION : 07/01/21
REVISION : 07/01/21

ASSEMBLY : **82-99-5000**

AUTHOR : G.HUBERDEAU