

AgriMetal

PARTS LIST

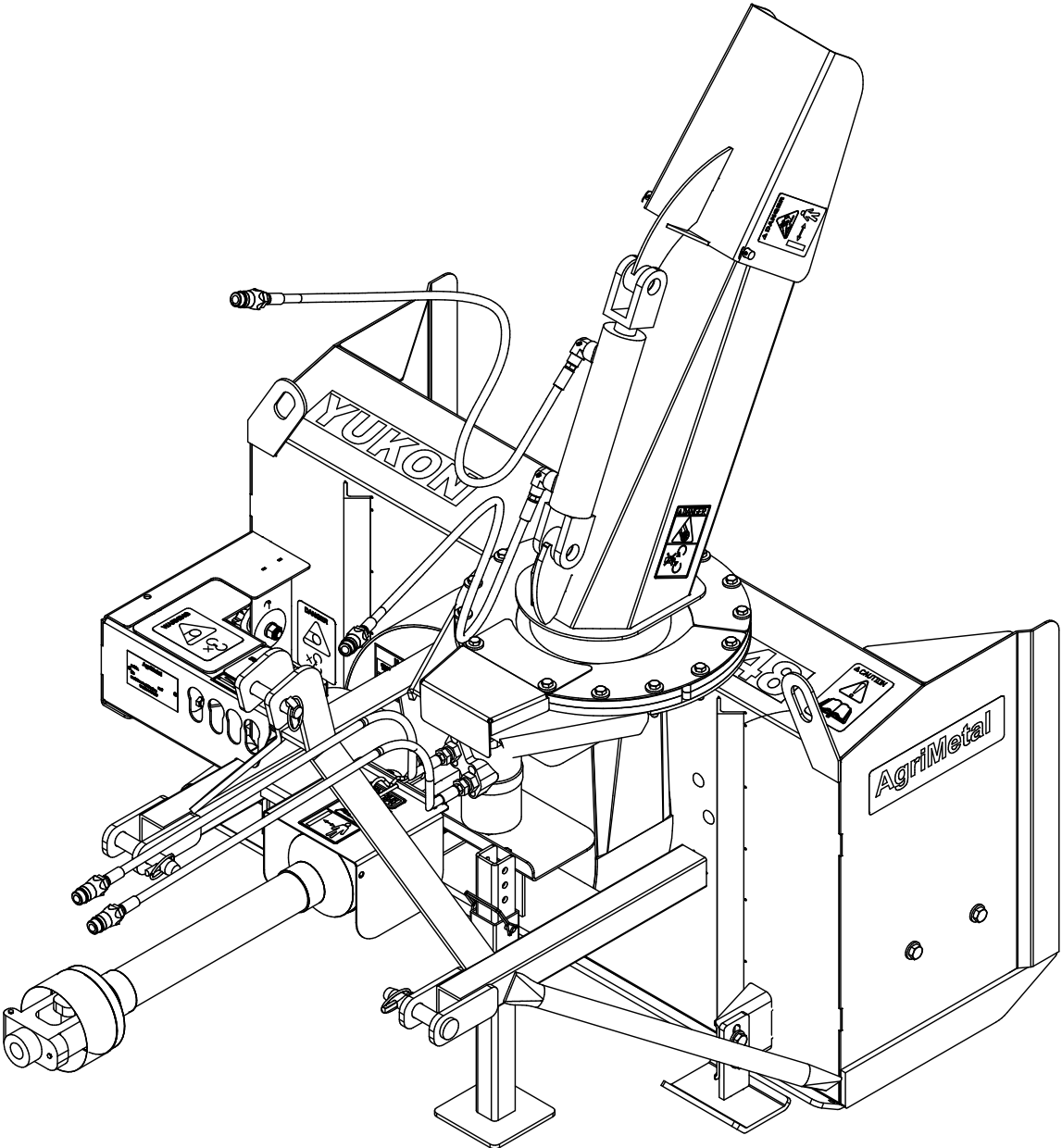

Y 2048

#	PART #	Qty	TITLE
1	86-57-0195	1	FRAME GROUP. "STICKER INCLUDED"
2	80-50-0093	1	STAND
3	85-20-0025	2	3 POINT PIN
4	86-20-0020	1	PIN (CAT. I)
5	NC01-69-1100	3	LINCH PIN 3/8"
6	25-55-0710	1	SERIAL NUMBER PLATE
7	NC01-69-1306	1	LOCKING PIN 3/8" X 2 1/2" LG

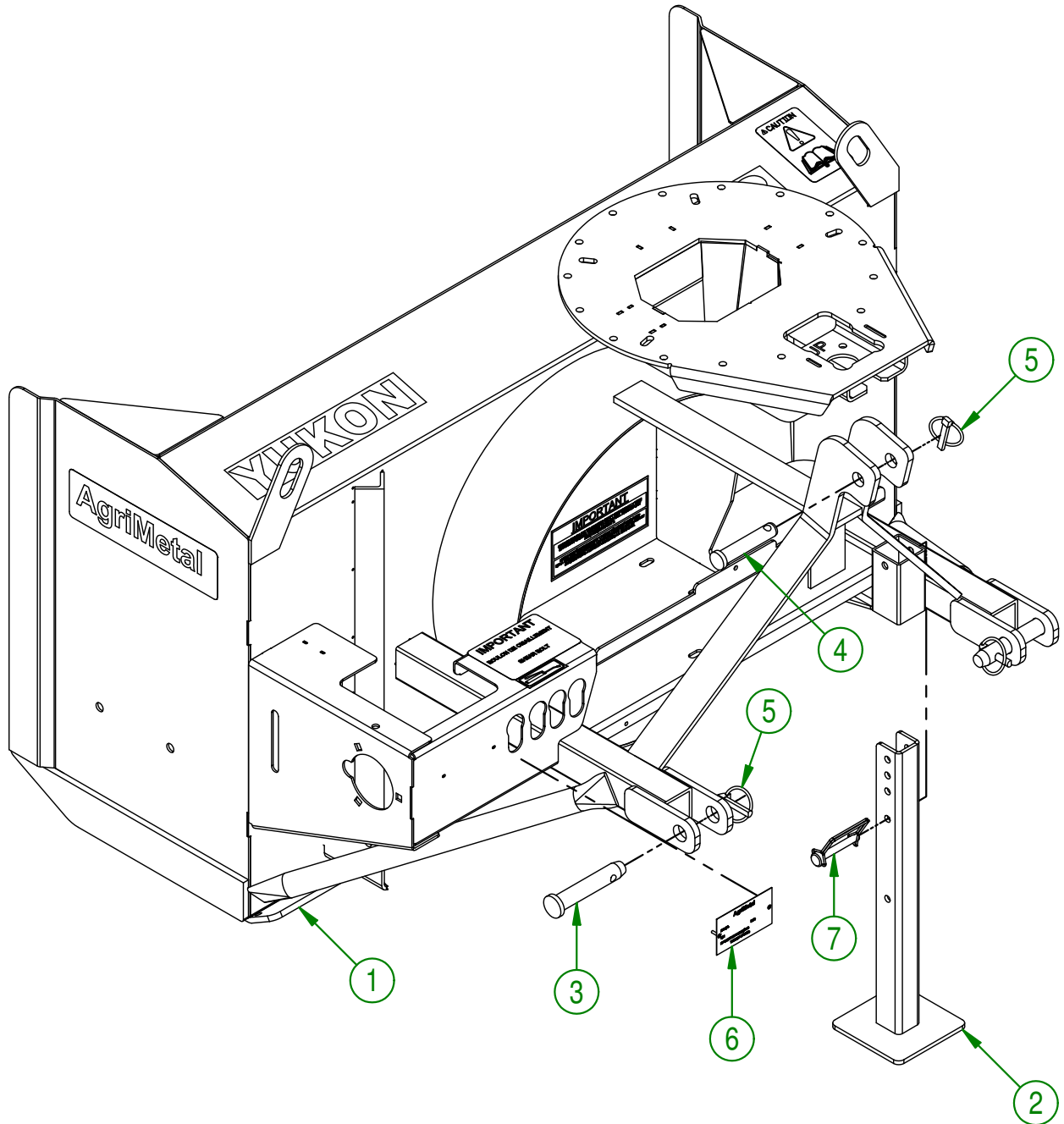

AGRIMETAL	
FRAME GROUP	
CREATION : 11/12/18	ASSEMBLY : 86-57-0190
REVISION : 21/05/19	AUTHOR : J.KABWE Page 1 de 22

86-57-0150

#	PART #	Qty	TITLE
1	86-55-0150	1	GEARBOX ASSY. Y20
2	86-34-0005	1	PTO SHAFT YUKON 20 T20
3	NC01-25-0130	4	HEX. BOLT GR5 NC ZINC 3/8-16 X 5"
4	85-04-0165	8	WASHER
5	NC01-93-0011	4	LOCK NUT 3/8-16
6	86-41-0000	1	IMPELLER KEY
7	01-41-0910	1	KEY
8	NC02-44-0090	1	SCREW PRESSURE 6 PANS 1/4-20 X 3/8 "LG
9	NC01-44-0156	1	BOLT GR8.8 BLACK 7mm X 70mm
10	NC01-98-0102	1	NUT HEX.BLOCK.NYLO.SPEC 7MM
11	85-57-0400	1	OPERATION MANUAL

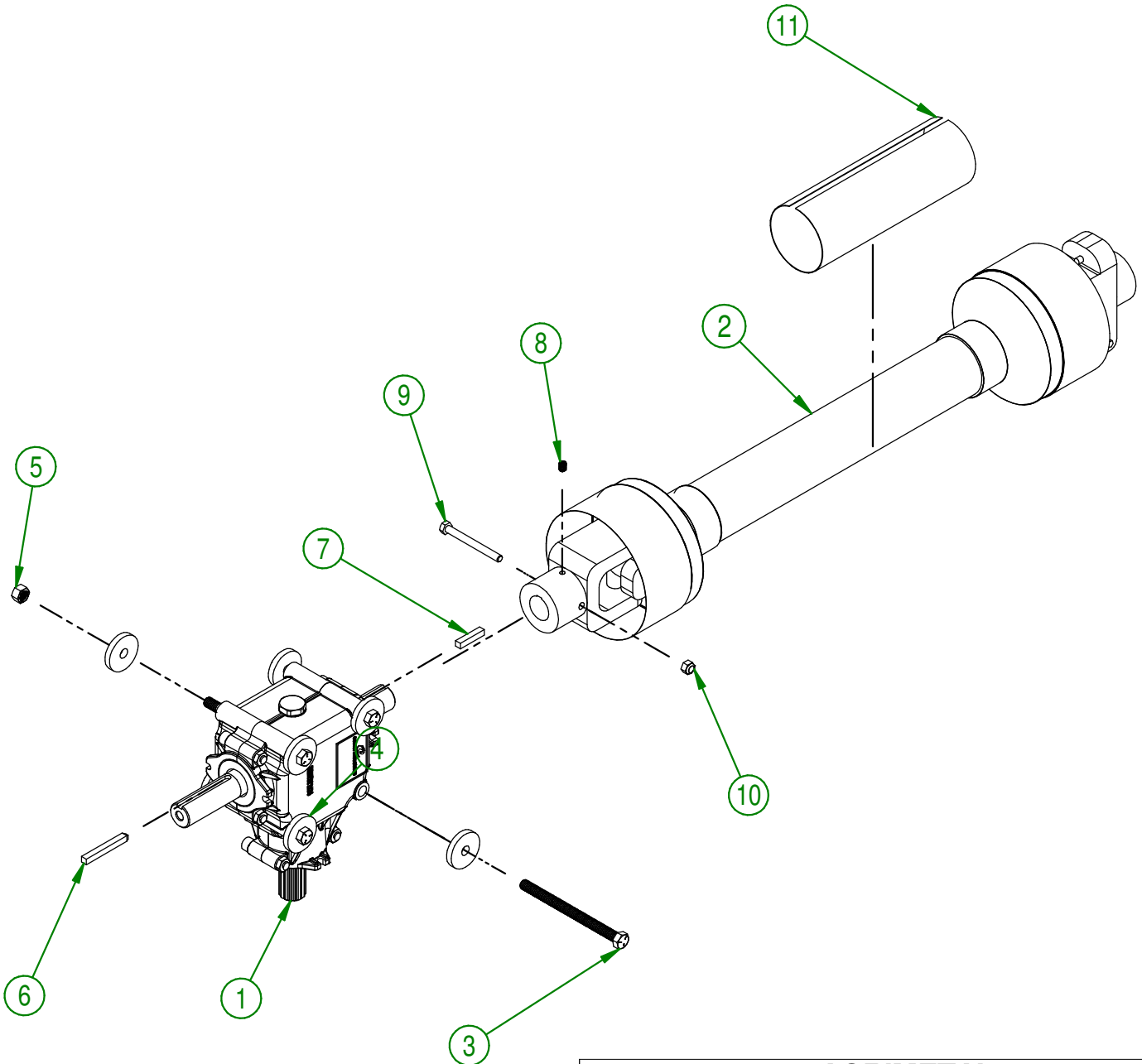

AGRIMETAL
GEARBOX GROUP

CREATION : 06/12/18
 REVISION : 21/05/19

ASSEMBLY : **86-57-0150**
 AUTHOR : J.KABWE

86-57-0160

#	PART #	Qty	TITLE
1	86-50-0070	1	IMPELLER
2	NC01-33-0062	1	HEX. BOLT GR2 ZINC 5/16-18 X 1 1/2" TOTAL LENGTH
3	NC02-32-0011	1	LOCK WASHER ZINC 5/16"
4	NC02-44-0102	2	SOCKET HEAD CAP SCREW 5/16-18 X 5/16"

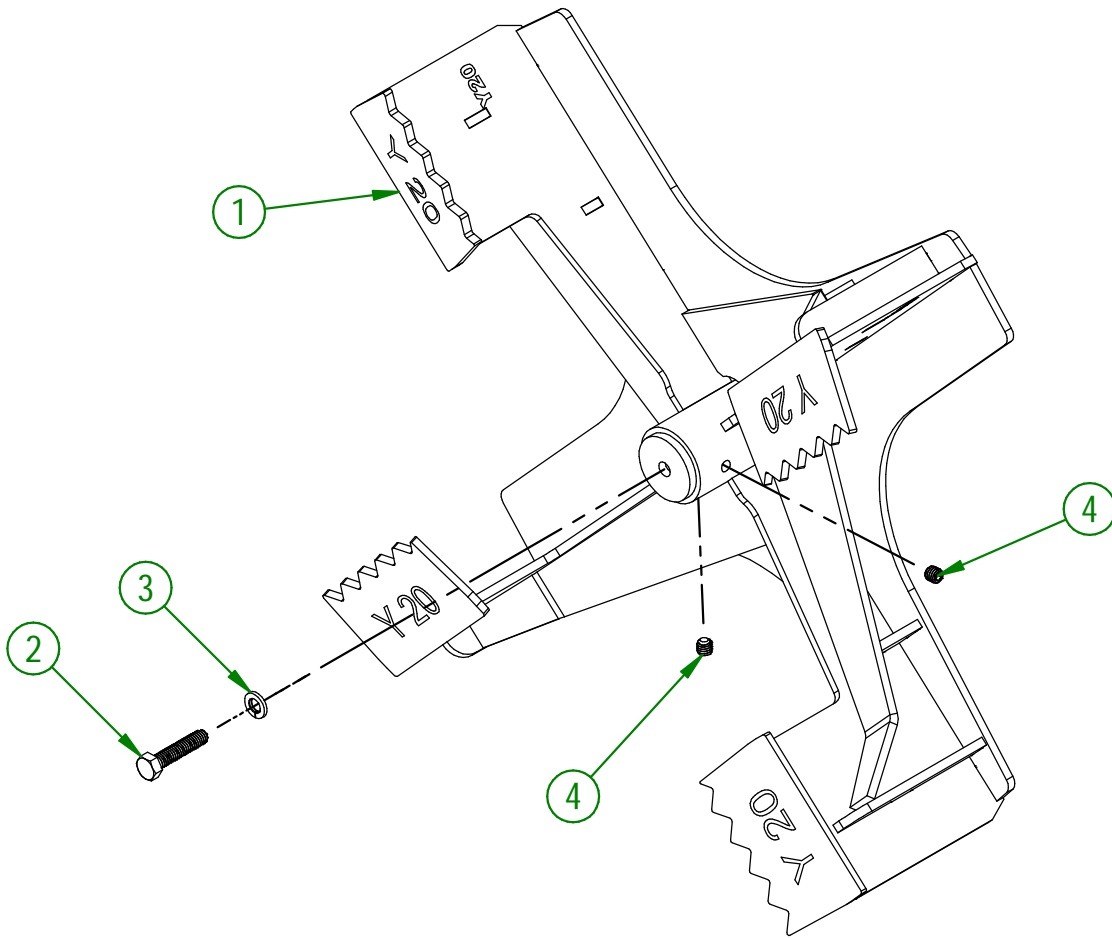

AGRIMETAL
IMPELLER GROUP

CREATION : 06/12/18
REVISION : 17/02/22

ASSEMBLY : **86-57-0160**
AUTHOR : J.KABWE

85-57-0050

#	PART #	Qty	TITLE
1	85-04-0060	1	IMPELLER DOOR
2	NC01-04-0107	3	CARR. BOLT GR2 ZINC 3/8-16 X 3/4"
3	NC02-32-0012	3	LOCK WASHER ZINC 3/8"
4	NC02-07-0018	3	HEX. NUT ZINC 3/8-16

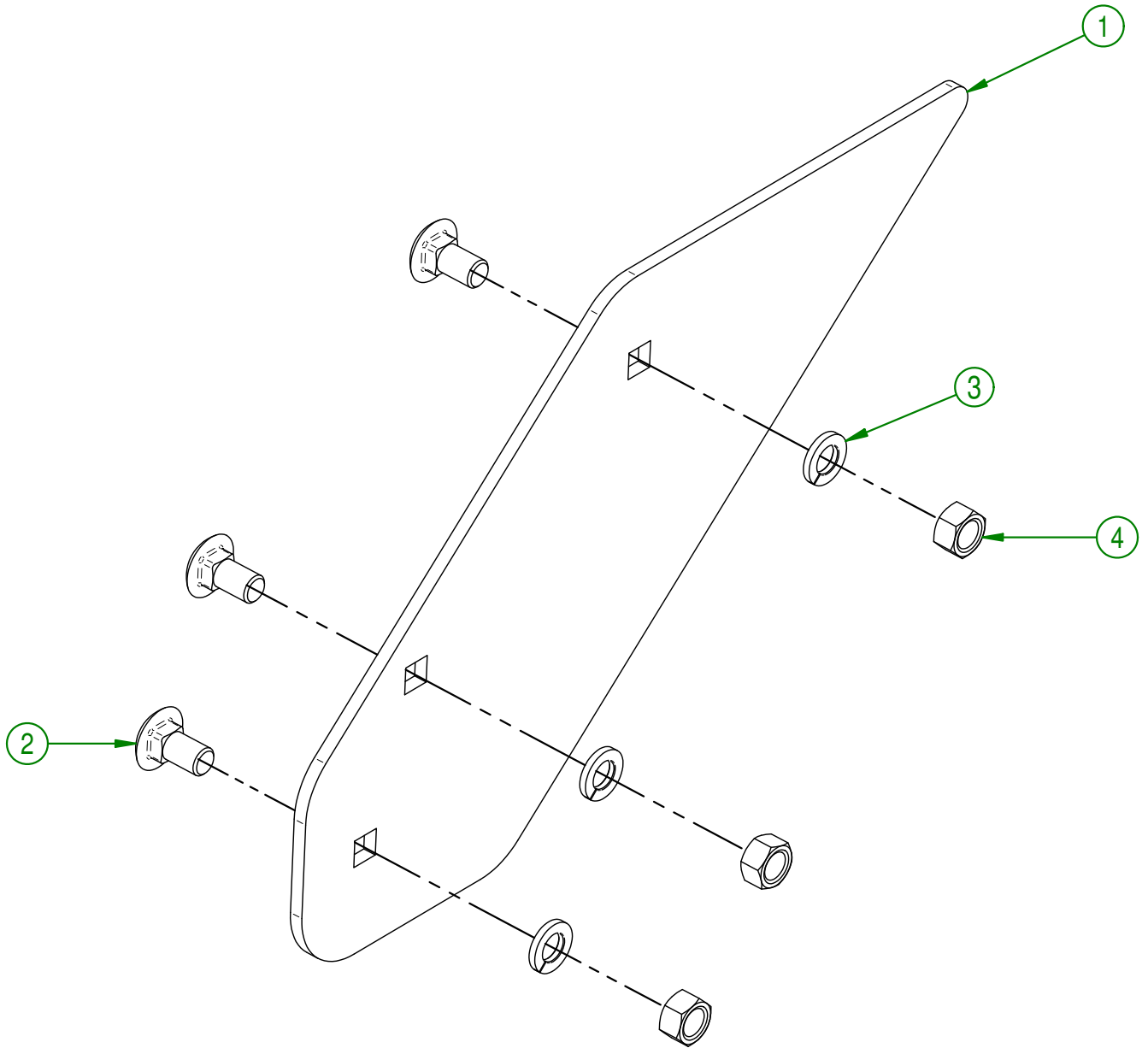

AGRIMETAL	
IMPELLER DOOR GROUP	
CREATION : 11/05/17	ASSEMBLY : 85-57-0050
REVISION : 21/05/19	AUTHOR : J.KABWE Page 4 de 22

86-57-0205

#	PART #	Qty	TITLE
1	86-50-0100	1	SPIRAL
2	NC14-75-0021	2	FLANGE PILLOW BLOCK BEARING UCFL207-20 \varnothing 1 1/4"
3	NC01-17-0250	2	HEX. BOLT GR2 ZINC 1/2-13 X 1 3/4"
4	NC01-17-0249	2	HEX. BOLT GR2 ZINC 1/2-13 X 1 1/2"
5	NC02-25-0011	4	WASHER SAE ZINC 17/32 ID
6	NC02-32-0014	4	LOCK WASHER ZINC 1/2"
7	NC02-07-0020	4	HEX. NUT ZINC 1/2-13
8	86-01-0190	1	SPIRAL SHIM
9	NC13-80-0061	4	PAD STEEL POWDER 1/2" X 5/8" X 3/8"
10	NC14-55-0294	1	SPROCKET 60A32H X 1 1/4" \varnothing + 4 \varnothing 25/64
11	NC01-94-0011	4	JAM NUT 3/8-24
12	NC01-37-0115	4	HEX. BOLT 3/8-24 X 1 1/4"

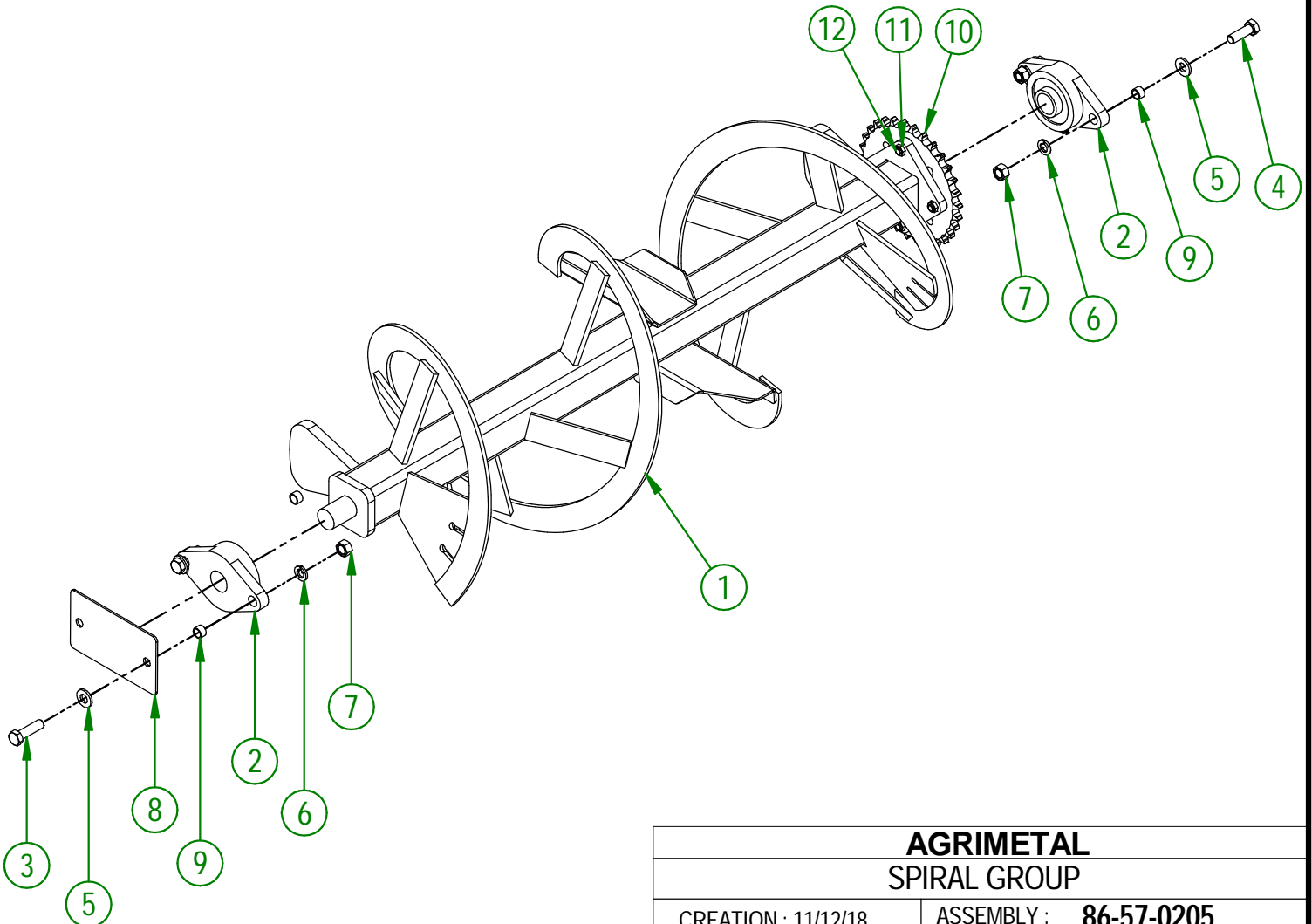

AGRIMETAL
SPIRAL GROUP

CREATION : 11/12/18
REVISION : 09/12/25

ASSEMBLY : **86-57-0205**
AUTHOR : J.KABWE

#	PART #	Qty	TITLE
1	NC14-75-0094	1	PRESSED STEEL FLANGE WITH GREASE FITTING
2	NC14-75-0093	1	PRESSED STEEL FLANGE
3	NC14-75-0164	1	SB207-20 BEARING
4	80-21-0025	1	SPIRAL DRIVE TRAIN BUSHING
5	NC14-55-0293	1	60B12H SPROCKET
6	86-50-0095	1	SPIRAL DRIVE TRAIN
7	NC01-04-0109	3	CARR. BOLT GR2 ZINC 3/8-16 X 1"
8	NC02-32-0012	3	LOCK WASHER ZINC 3/8"
9	NC02-07-0018	3	HEX. NUT ZINC 3/8-16
10	NC01-17-0063	1	CAP SCREW GR2 NC ZINC 5/16-18 X 1 3/4"
11	NC01-93-0010	1	LOCK NUT ZINC 5/16-18
12	85-04-0420	2	WASHER
13	NC01-29-0261	1	HEX. BOLT GR.5 N ZINC 1/2-20 4 1/2"
14	85-21-0000	1	CHAIN TENSIONER BUSHING (SPROCKET)
15	NC14-55-0295	1	SPROCKET 60A12H
16	85-21-0005	1	CHAIN TENSIONER BUSHING (SPROCKET)
17	NC02-32-0014	1	LOCK WASHER ZINC 1/2"
18	NC02-10-0020	1	HEX. NUT ZINC 1/2-20
19	86-37-0005	1	# 60 HD CHAIN 53"

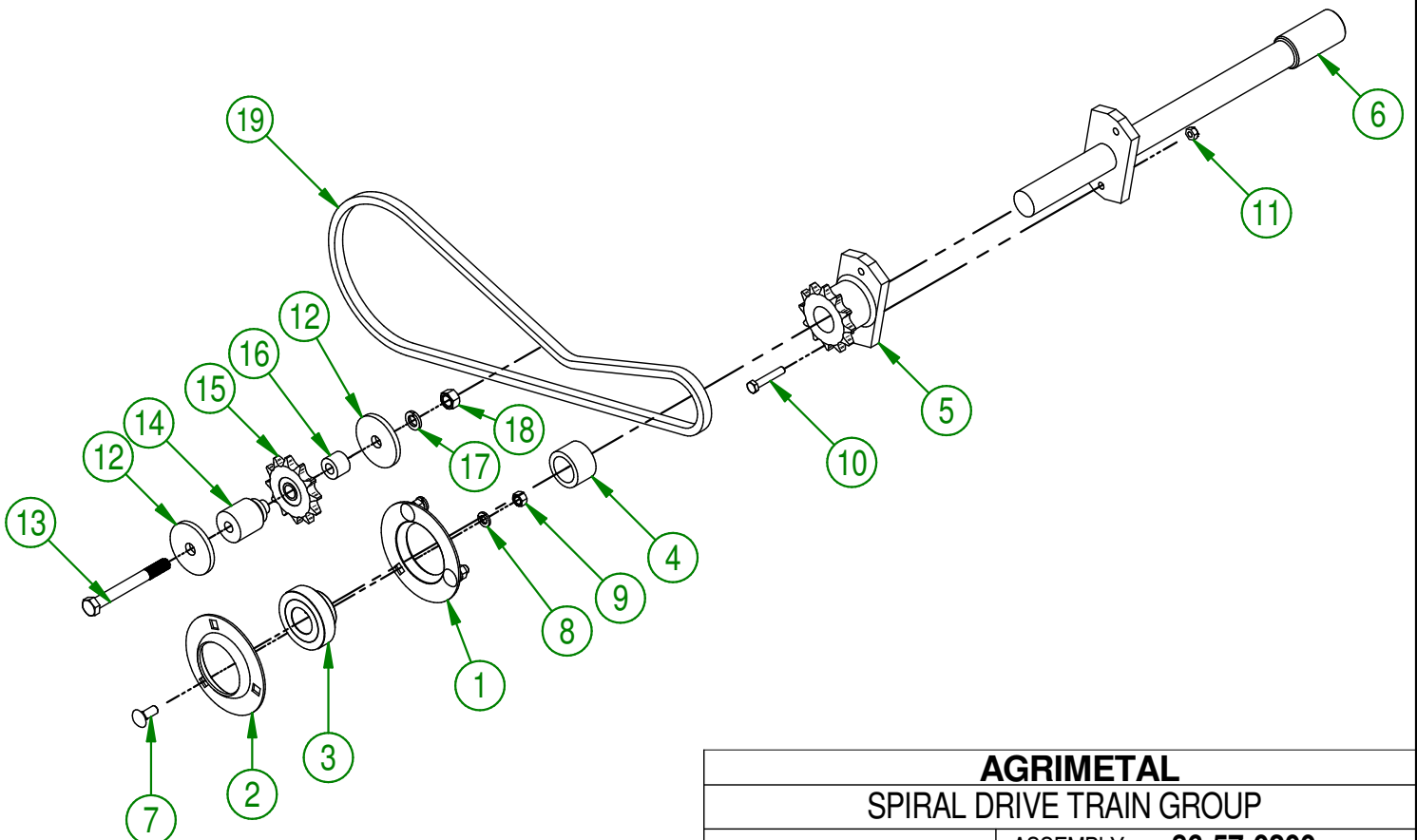
**AGRIMETAL****SPIRAL DRIVE TRAIN GROUP**

CREATION : 10/12/18
 REVISION : 05/05/21

ASSEMBLY : **86-57-0200**
 AUTHOR : J.KABWE

85-57-0035

#	PART #	Qty	TITLE
1	85-57-0036	1	SPIRAL DRIVE TRAIN DOOR GROUP. "STICKER INCLUDED"
2	NC02-29-0028	1	PLASTIC WASHER 13/16" OD X 13/32" ID
3	NC02-26-1525	2	WASHER INOX .406" D.I. X .815" D.E.
4	NC01-25-0114	1	HEX. BOLT GR5 ZINC 3/8-16 X 1"
5	NC01-96-0011	1	NYLON NUT 3/8-16

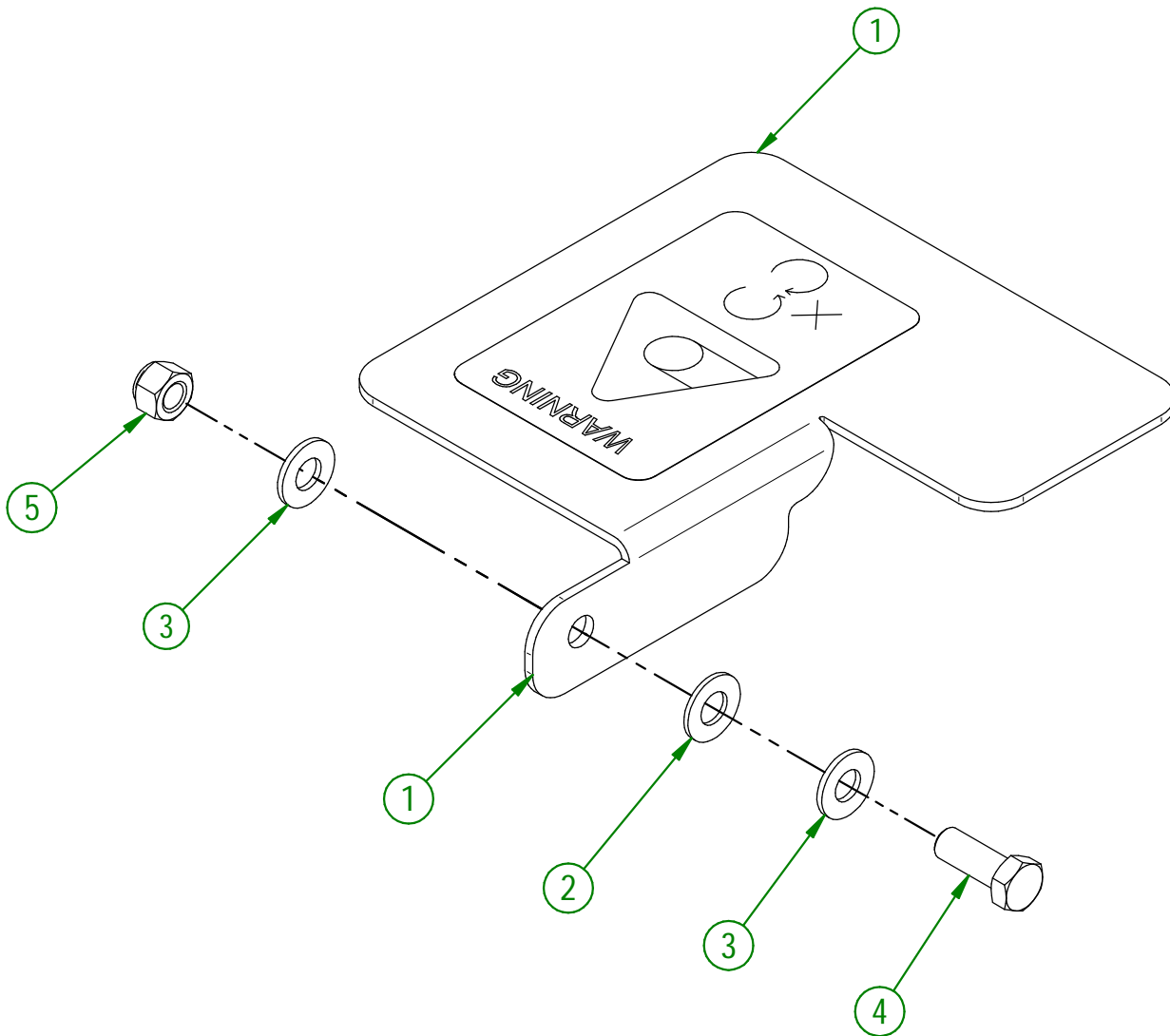

AGRIMETAL	
SPIRAL DRIVE TRAIN DOOR GROUP	
CREATION : 11/05/17	ASSEMBLY : 85-57-0035
REVISION : 23/12/25	AUTHOR : J.KABWE

86-57-0115

#	PART #	Qty	TITLE
1	86-57-0116	1	GEARBOX GUARD GROUP "STICKER INCLUDED"
2	80-41-0135	1	PTO GUARD STEEL CABLE
3	NC01-64-0005	2	OVAL SLEEVE (ALUMINUM)
4	NC01-63-0027	1	HAIRPIN COTTER

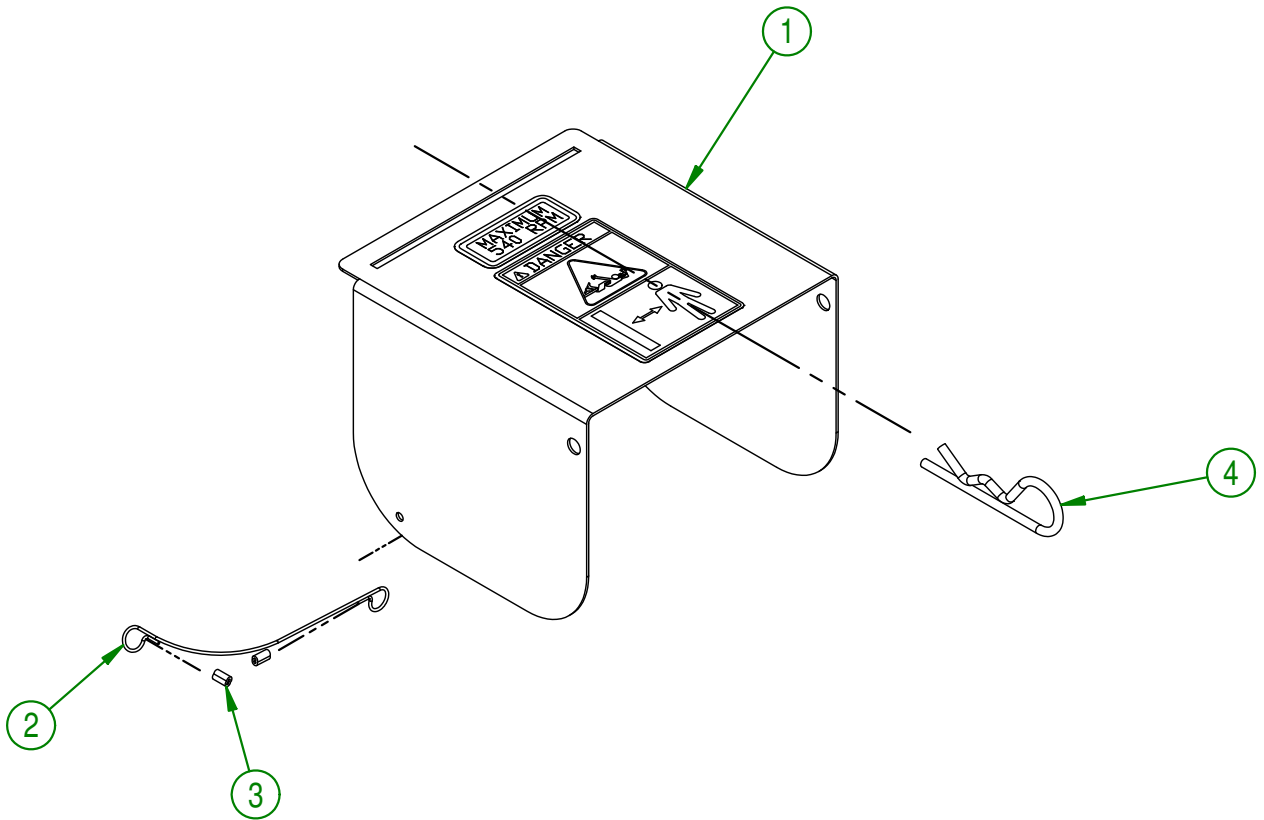

AGRIMETAL	
GEARBOX GUARD GROUP	
CREATION : 15/05/17	ASSEMBLY : 86-57-0115
REVISION : 21/05/19	AUTHOR : J.KABWE Page 8 de 22

#	PART #	Qty	TITLE
1	85-50-0025	2	SKATE
2	01-01-0925	4	WASHER
3	NC01-17-0249	4	HEX. BOLT GR2 ZINC 1/2-13 X 1 1/2"
4	NC02-32-0014	4	LOCK WASHER ZINC 1/2"
5	NC02-07-0020	4	HEX. NUT ZINC 1/2-13

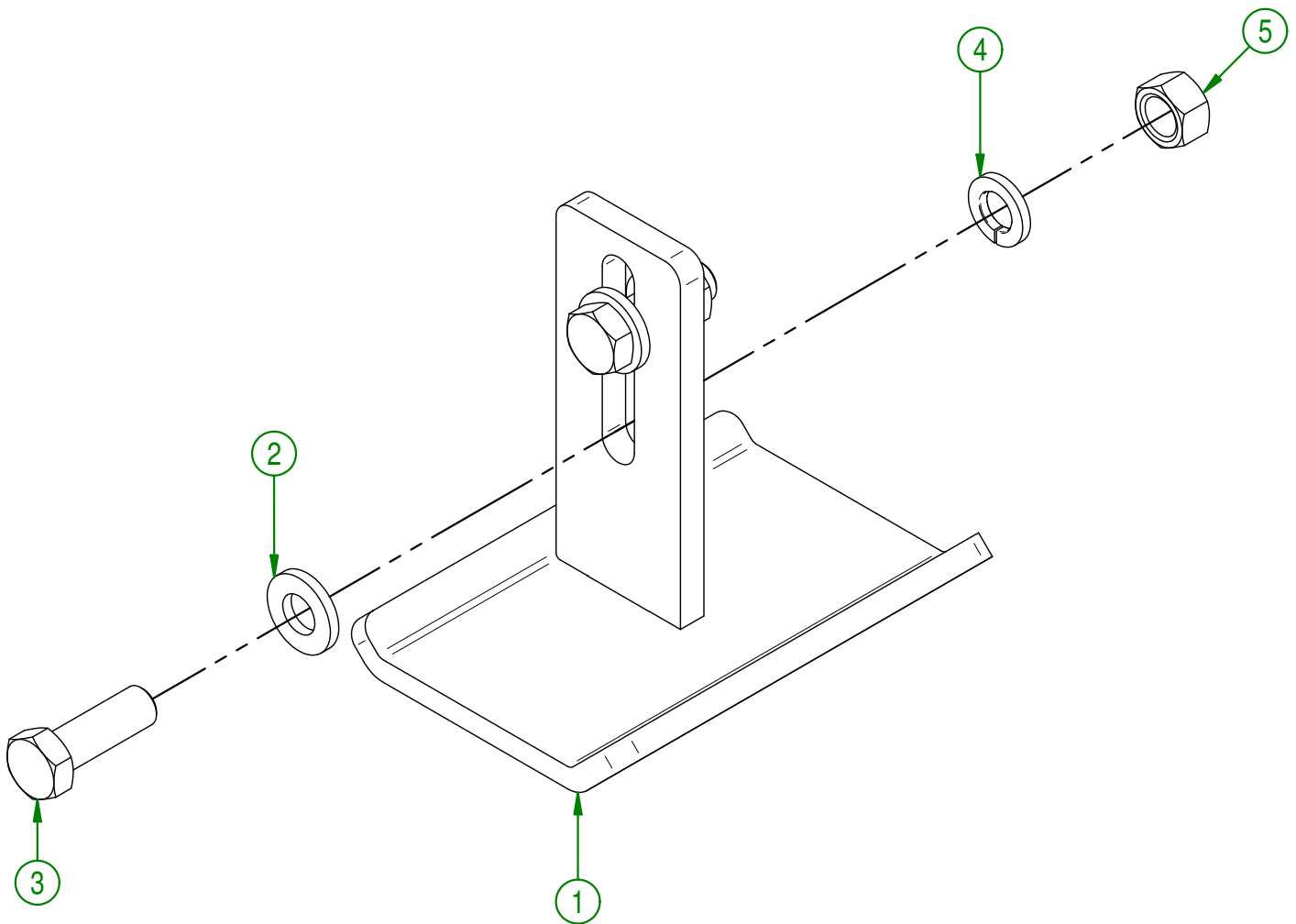

AGRIMETAL	
ADJUSTABLE SKATE GROUP (LEFT & RIGHT) (OPTION)	
CREATION : 11/05/17	ASSEMBLY : 85-57-0170
REVISION : 14/05/18	AUTHOR : J.KABWE Page 9 de 22

#	PART #	Qty	TITLE
1	86-57-0235	1	CHUTE GROUP
2	86-57-0135	1	HYDRAULIC MOTOR GROUP

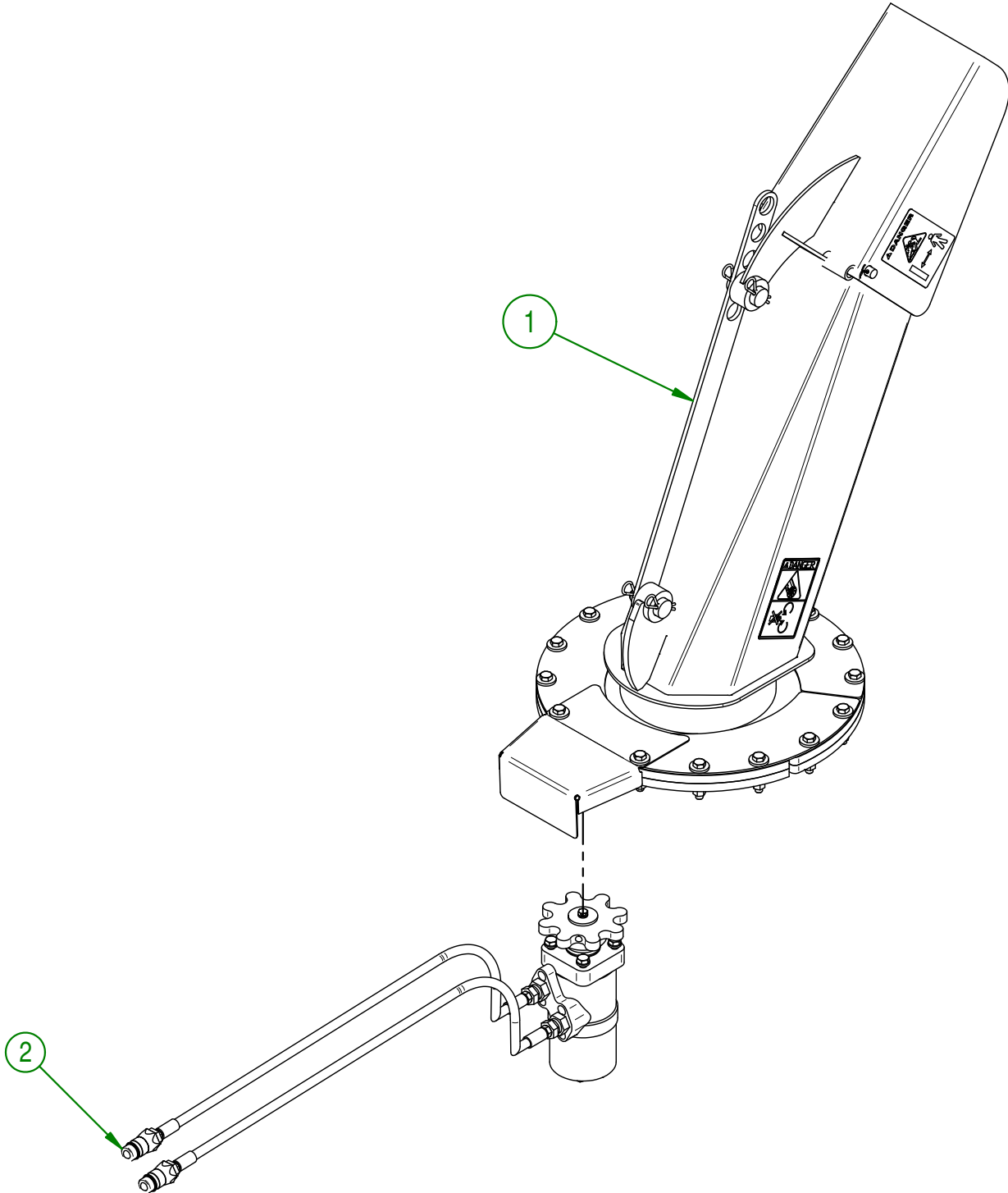

AGRIMETAL	
HYDRAULIC CHUTE GROUP (OPTION)	
CREATION : 13/03/19	ASSEMBLY : 86-57-0230
REVISION : 21/05/19	AUTHOR : J.KABWE Page 10 de 22

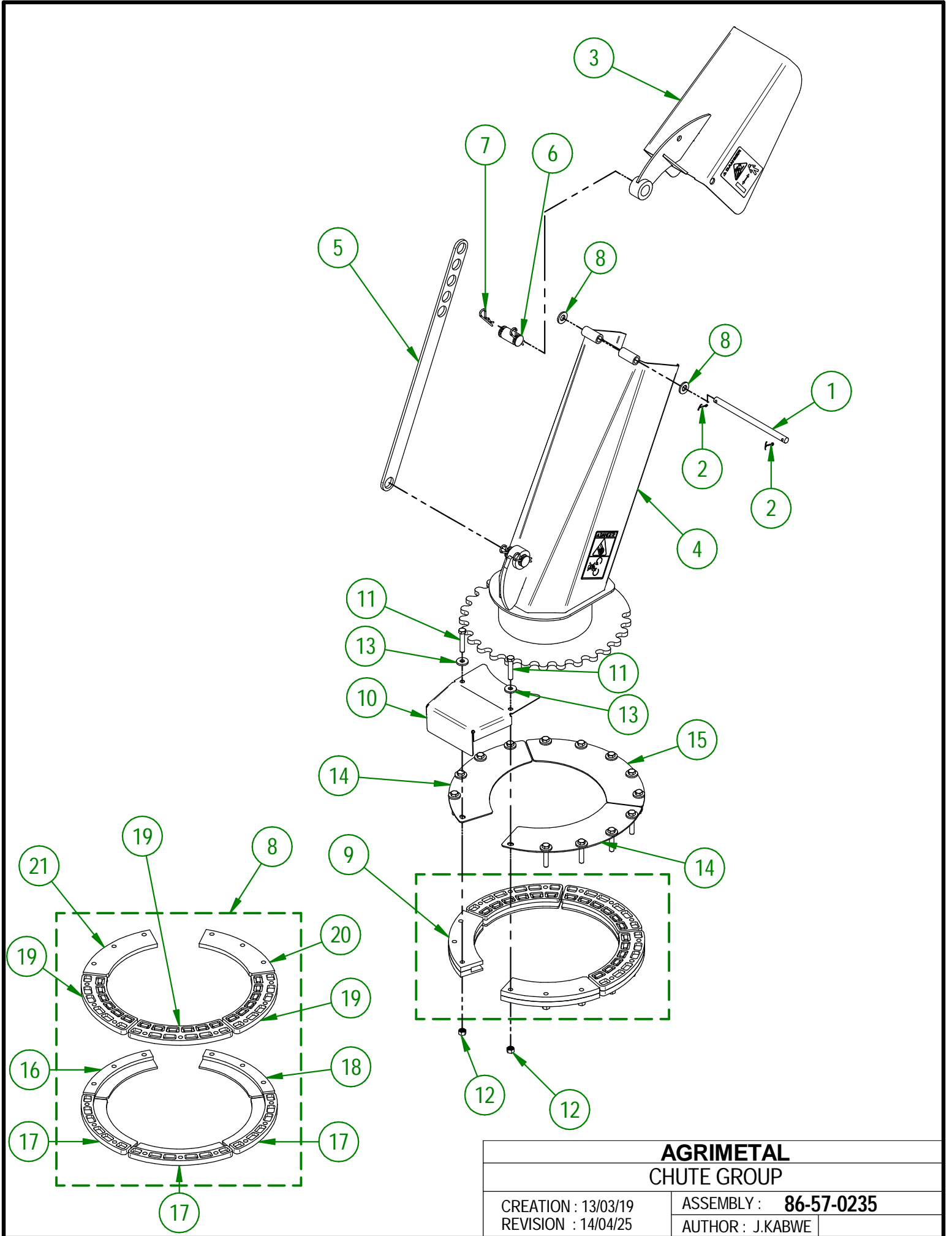

AGRIMETAL
CHUTE GROUP

CREATION : 13/03/19
 REVISION : 14/04/25

ASSEMBLY : **86-57-0235**
 AUTHOR : J.KABWE

86-57-0235

#	PART #	Qty	TITLE
1	86-13-0050	1	PIVOT
2	NC01-69-0139	2	COTTER PIN ZINC 1/8" X 3/4"
3	86-57-0175	1	CHUTE GROUP UP SECTION
4	86-57-0180	1	CHUTE GROUP DOWN SECTION
5	85-04-0450	1	CHUTE DEFLECTOR ADJUSTABLE PLATE
6	85-13-0480	2	PIVOT CHUTE DEFLECTOR PLATE
7	NC01-63-0015	4	COTTER PIN Z 1/8" X 2 5/8"
8	NC02-25-0011	2	WASHER SAE ZINC 17/32 ID
9	84-57-1325	1	CHUTE GUIDE GROUP
10	86-01-0215	1	SPROCKET GUARD
11	NC01-17-0118	15	HEX. BOLT GR2 ZINC 3/8-16 X 2"
12	NC01-93-0011	15	LOCK NUT 3/8-16
13	21-01-0950	15	FLAT WASHER 10GA 1.005" DIA X 25/64"
14	86-01-0205	2	BRACE
15	86-01-0210	1	BRACE

84-57-1325

#	PART #	Qty	TITLE
16	46-42-0107	1	CHUTE GUIDE (UNDER)
17	NC17-46-0030	3	CHUTE GUIDE (UNDER)
18	46-42-0106	1	CHUTE GUIDE (UNDER)
19	NC17-46-0029	3	CHUTE GUIDE (TOP)
20	46-42-0101	1	CHUTE GUIDE (TOP)
21	46-42-0102	1	CHUTE GUIDE (TOP)

#	PART #	Qty	TITLE
1	NC14-45-0150	1	HYDRAULIC MOTOR 315
2	48-50-1025	1	HYDRAULIC ENGINE SPROCKET
3	NC02-32-0012	4	LOCK WASHER ZINC 3/8"
4	NC01-33-0113	4	HEX.BOLT GR8 ZINC 3/8-16 X 3/4"
5	NC02-22-0009	1	WASHER
6	NC02-32-0010	1	LOCK WASHER ZINC 1/4"
7	NC01-33-0005	1	HEX. BOLT GR8 ZINC 1/4-20 X 7/8"
8	NC13-45-0073	2	STRAIGHT 7/8-14 MALE SAE10 O-RING X 3/8 FEM. TOUR. NPT
9	NC13-45-0285	2	QUICK COUPLER 3/8 NPTF
10	NC13-45-0301	2	HEX. REDUCER 1/4 FEM. NPT X 3/8 MÂLE NPT
11	NC17-02-0417	2	HYDRAULIC HOSE (51" LG)
12	NC17-46-0031	1	HYDRAULIC MOTOR BUSHING
13	NC02-44-0103	2	SET SCREW 5/16-18 X 3/8"

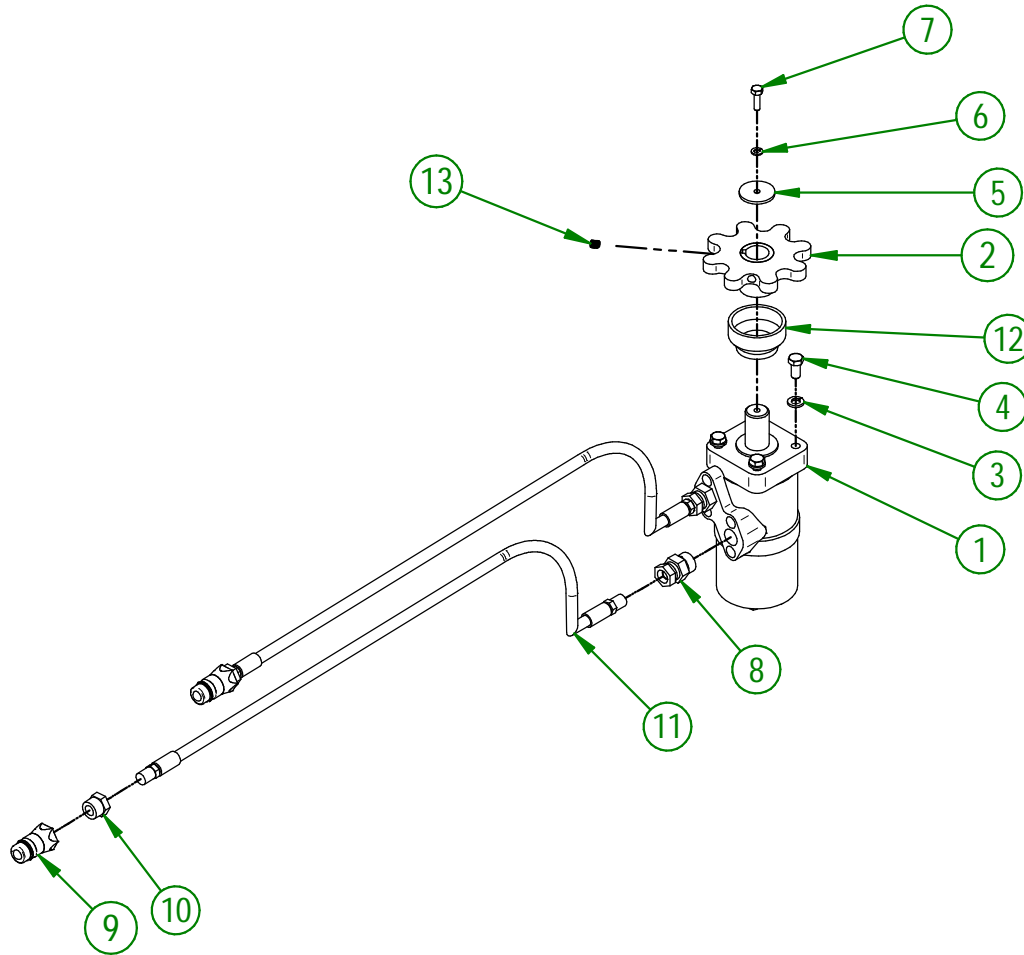

AGRIMETAL	
HYDRAULIC MOTOR GROUP	
CREATION : 19/09/17	ASSEMBLY : 86-57-0135
REVISION : 11/12/25	AUTHOR : J.KABWE

86-57-0185

#	PART #	Qty	TITLE
1	86-57-0170	1	CHUTE GROUP
2	86-57-0135	1	HYDRAULIC MOTOR GROUP

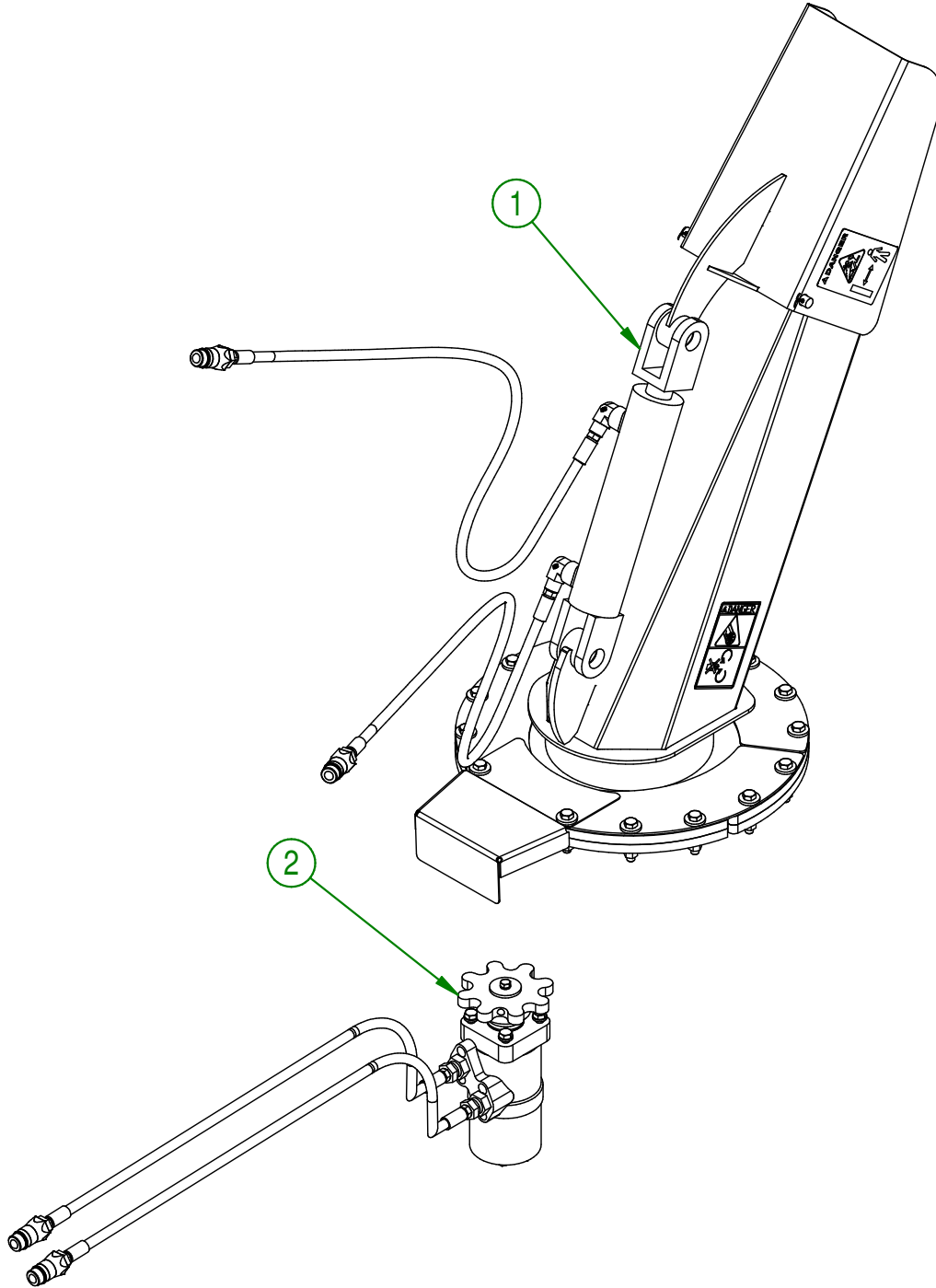

AGRIMETAL	
HYDRAULIC CHUTE GROUP (OPTION)	
CREATION : 21/05/19	ASSEMBLY : 86-57-0185
REVISION : 21/05/19	AUTHOR : F.HÉLIE

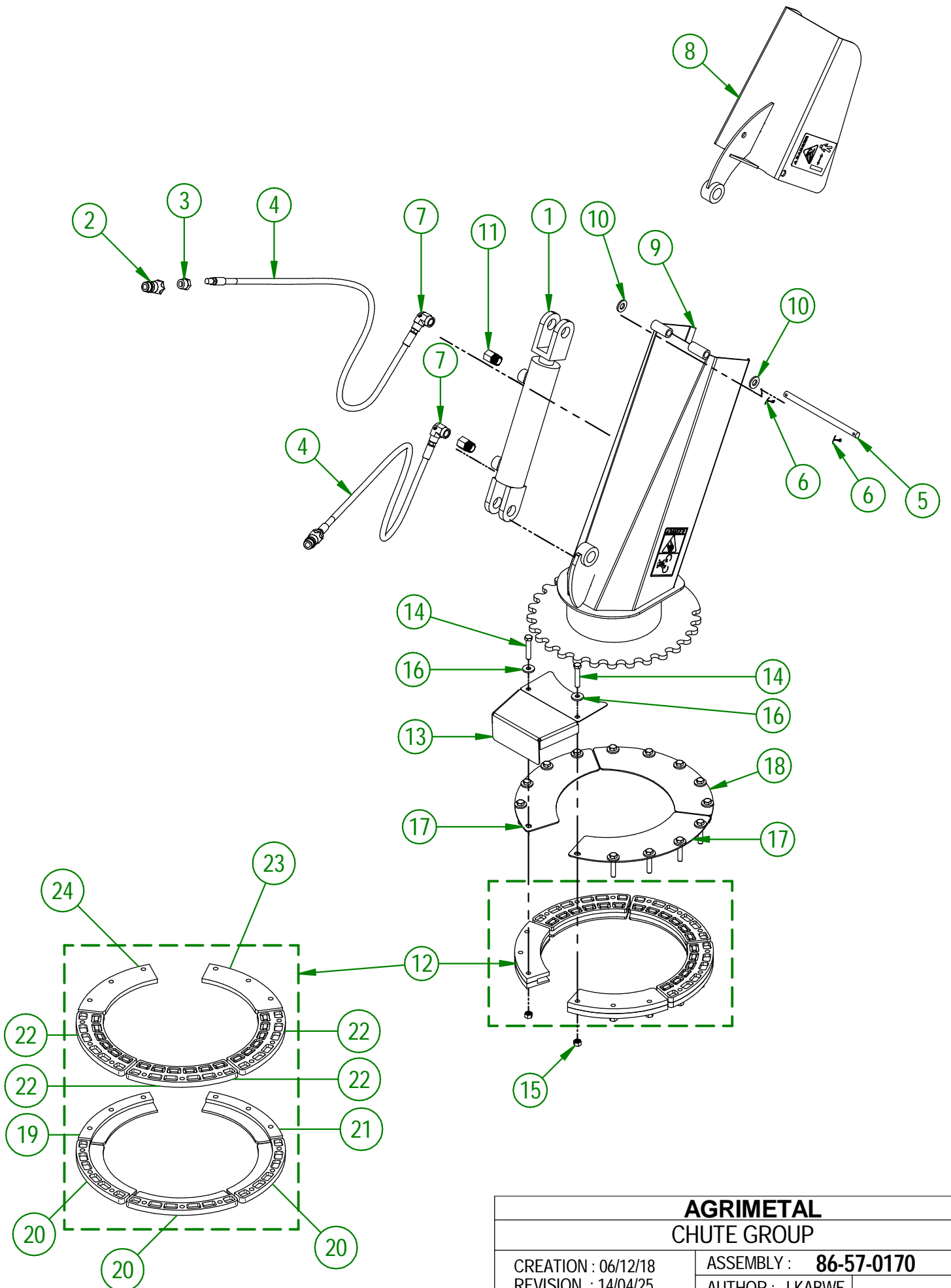

AGRIMETAL
CHUTE GROUP

CREATION : 06/12/18
 REVISION : 14/04/25

ASSEMBLY : **86-57-0170**
 AUTHOR : J.KABWE

86-57-0170

#	PART #	Qty	TITLE
1	NC13-45-0377	1	HYDRAULIC CYLINDER 6"
2	NC13-45-0285	2	QUICK COUPLER 3/8 NPTF
3	NC13-45-0301	2	HEX. REDUCER 1/4 FEM. NPT X 3/8 MÂLE NPT
4	NC17-02-0416	2	HYDRAULIC HOSE (75" LG)
5	86-13-0050	1	PIVOT
6	NC01-69-0139	2	COTTER PIN ZINC 1/8" X 3/4"
7	NC13-45-0038	2	ELBOW 90 3/8 FEM. NPT X 3/8 MALE NPT
8	86-57-0175	1	CHUTE GROUP UP SECTION
9	86-57-0180	1	CHUTE GROUP DOWN SECTION
10	NC02-25-0011	2	WASHER SAE ZINC 17/32 ID
11	NC13-45-0268	2	UNION RIGHT MALE SAE6 ORING FEM.NPT
12	84-57-1325	1	CHUTE GUIDE GROUP
13	86-01-0215	1	SPROCKET GUARD
14	NC01-17-0118	15	HEX. BOLT GR2 ZINC 3/8-16 X 2"
15	NC01-93-0011	15	LOCK NUT 3/8-16
16	21-01-0950	15	FLAT WASHER 10GA 1.005" DIA X 25/64"
17	86-01-0205	2	BRACE
18	86-01-0210	1	BRACE

84-57-1325

#	PART #	Qty	TITLE
19	46-42-0107	1	CHUTE GUIDE (UNDER)
20	NC17-46-0030	3	CHUTE GUIDE (UNDER)
21	46-42-0106	1	CHUTE GUIDE (UNDER)
22	NC17-46-0029	3	CHUTE GUIDE (TOP)
23	46-42-0101	1	CHUTE GUIDE (TOP)
24	46-42-0102	1	CHUTE GUIDE (TOP)

#	PART #	Qty	TITLE
1	NC14-45-0150	1	HYDRAULIC MOTOR 315
2	48-50-1025	1	HYDRAULIC ENGINE SPROCKET
3	NC02-32-0012	4	LOCK WASHER ZINC 3/8"
4	NC01-17-0112	4	HEX. BOLT GR2 ZINC 3/8-16 X 3/4"
5	NC02-22-0009	1	WASHER
6	NC02-32-0010	1	LOCK WASHER ZINC 1/4"
7	NC01-33-0005	1	HEX. BOLT GR8 ZINC 1/4-20 X 7/8"
8	NC13-45-0073	2	STRAIGHT 7/8-14 MALE SAE10 O-RING X 3/8 FEM. TOUR. NPT
9	NC13-45-0285	2	QUICK COUPLER 3/8 NPTF
10	NC13-45-0301	2	HEX. REDUCER 1/4 FEM. NPT X 3/8 MÂLE NPT
11	NC17-02-0417	2	HYDRAULIC HOSE (51" LG)
12	NC17-46-0031	1	HYDRAULIC MOTOR BUSHING
13	NC02-44-0103	2	SET SCREW 5/16-18 X 3/8"

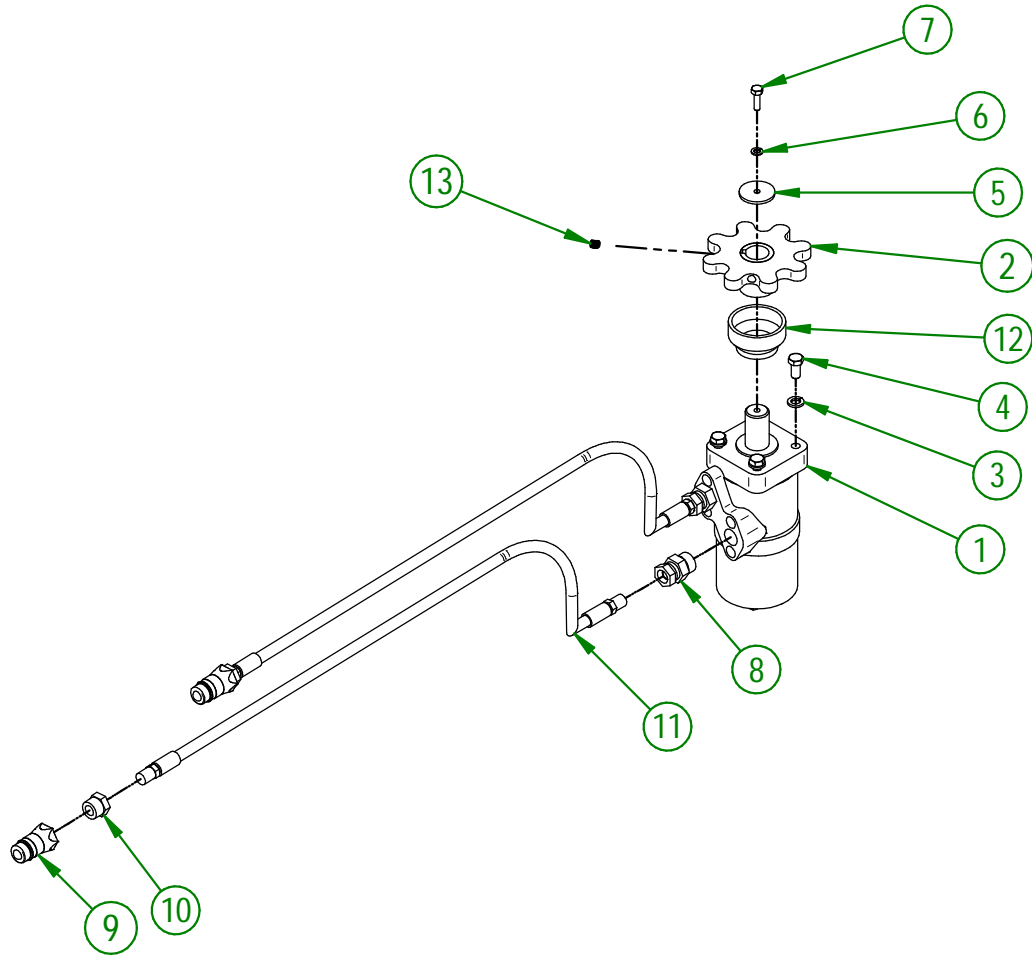

AGRIMETAL	
HYDRAULIC MOTOR GROUP	
CREATION : 19/09/17	ASSEMBLY : 86-57-0135
REVISION : 03/03/23	AUTHOR : J.KABWE

86-57-0240

#	PART #	Qty	TITLE
1	86-57-0245	1	CHUTE GROUP
2	86-57-0131	1	MANUAL SYSTEM CHUTE GROUP

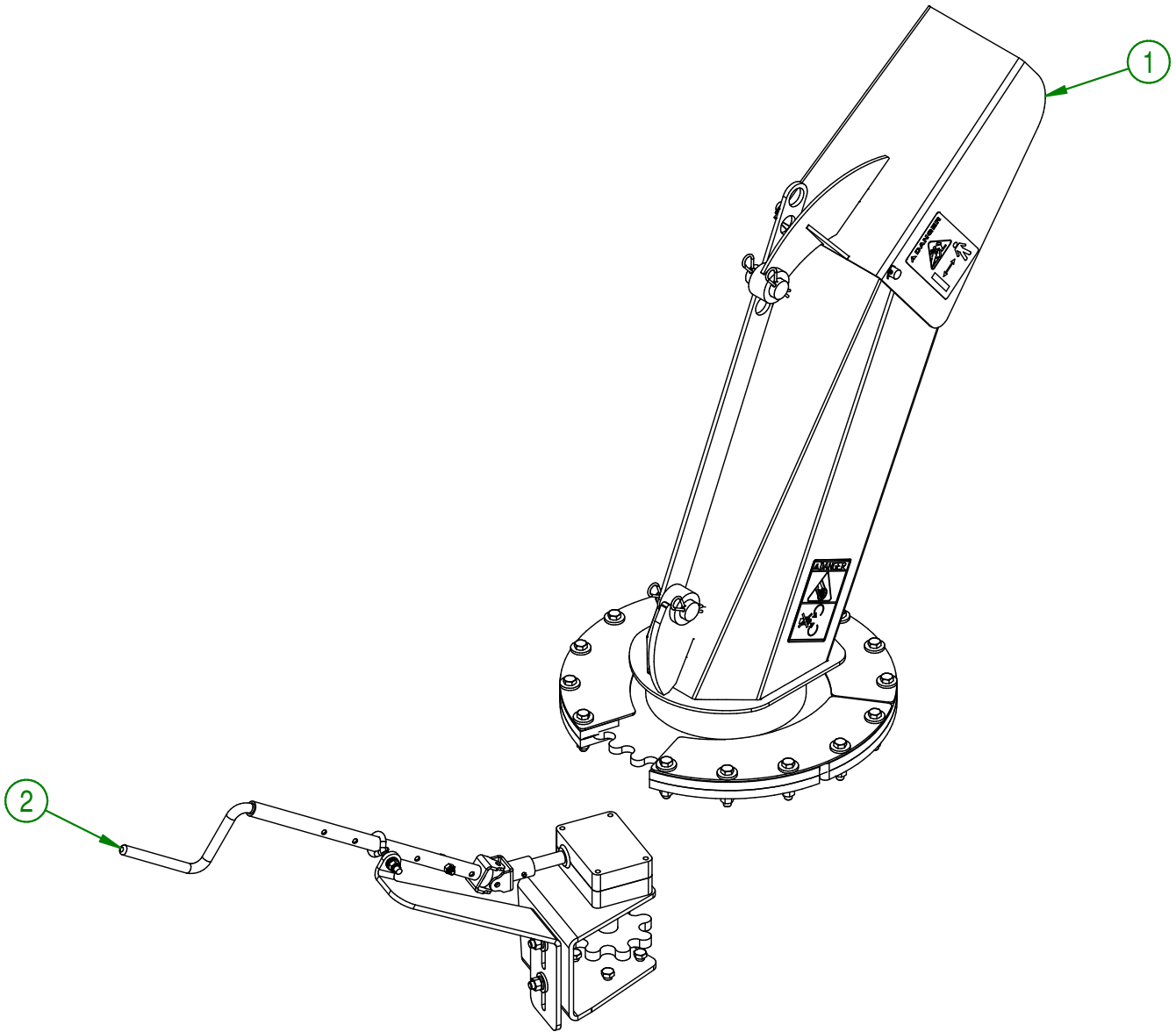

AGRIMETAL	
HYDRAULIC CHUTE GROUP (OPTION)	
CREATION : 25/04/19	ASSEMBLY : 86-57-0240
REVISION : 27/06/19	AUTHOR : F.HÉLIE

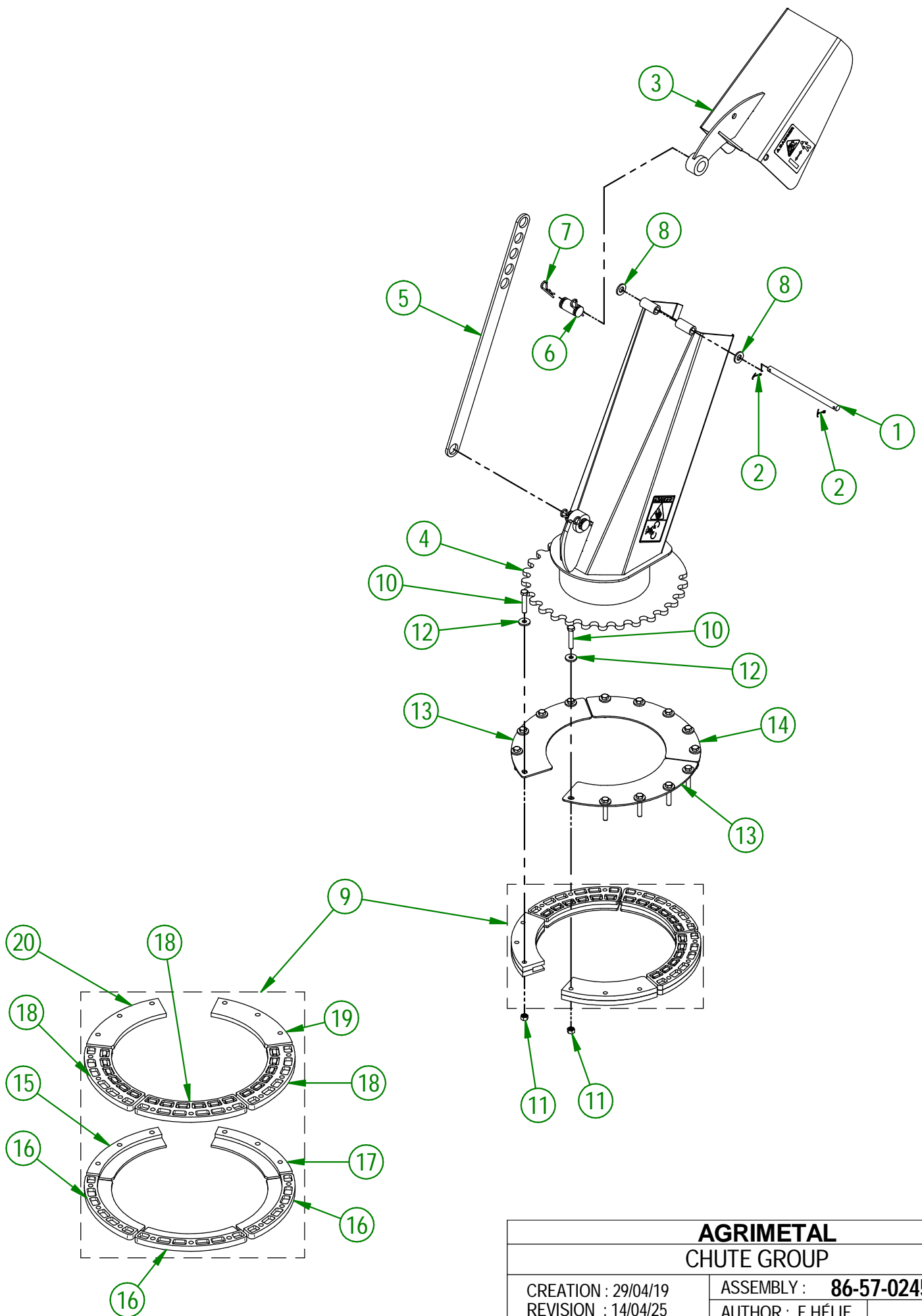

AGRIMETAL	
CHUTE GROUP	
CREATION : 29/04/19	ASSEMBLY : 86-57-0245
REVISION : 14/04/25	AUTHOR : F.HÉLIE

86-57-0245

#	PART #	Qty	TITLE
1	86-13-0050	1	PIVOT
2	NC01-69-0139	2	COTTER PIN ZINC 1/8" X 3/4"
3	86-57-0175	1	CHUTE GROUP UP SECTION
4	86-57-0180	1	CHUTE GROUP DOWN SECTION
5	85-04-0450	1	CHUTE DEFLECTOR ADJUSTABLE PLATE
6	85-13-0480	2	PIVOT CHUTE DEFLECTOR PLATE
7	NC01-63-0015	4	COTTER PIN Z 1/8" X 2 5/8"
8	NC02-25-0011	2	WASHER SAE ZINC 17/32 ID
9	84-57-1325	1	CHUTE GUIDE GROUP
10	NC01-17-0118	15	HEX. BOLT GR2 ZINC 3/8-16 X 2"
11	NC01-93-0011	15	LOCK NUT 3/8-16
12	21-01-0950	15	FLAT WASHER IOGA 1.005" DIA X 25/64"
13	82-01-0965	2	BRACE
14	82-01-0955	1	BRACE

84-57-1325

#	PART #	Qty	TITLE
15	46-42-0107	1	CHUTE GUIDE (UNDER)
16	NC17-46-0030	3	CHUTE GUIDE (UNDER)
17	46-42-0106	1	CHUTE GUIDE (UNDER)
18	NC17-46-0029	3	CHUTE GUIDE (TOP)
19	46-42-0101	1	CHUTE GUIDE (TOP)
20	46-42-0102	1	CHUTE GUIDE (TOP)

#	PART #	Qty	TITLE
1	NC01-17-0114	4	HEX. BOLT GR2 ZINC 3/8-16 X 1"
2	NC02-32-0012	6	LOCK WASHER ZINC 3/8"
3	NC02-07-0018	6	HEX. NUT ZINC 3/8-16
4	86-01-0280	1	SPROCKET GUARD
5	85-03-0000	2	CHUTE SHIM
6	85-03-0001	1	CHUTE SHIM
7	86-50-0130	1	MANUAL CHUTE SPROCKET
8	85-21-0016	1	BALL JOINT
9	86-13-0075	1	CRANK ROD
10	NC01-97-0004	1	NYLON-INSERT LOCKNUT ZINC 1/4-28
11	NC01-37-0007	1	HEX.BOLT GR8 NF ZINC 1/4-28 X 1 1/4
12	NC01-52-0109	1	EYE BOLT 5/16-18X Ø 3/4" INT. X 3 1/4"LG
13	NC01-04-0110	2	CARR. BOLT GR2 ZINC 3/8-16 X 1 1/4"
14	NCI4-10-0166	1	GEARBOX
15	86-50-0056	1	ADJUSTABLE TUBE (MANUAL CHUTE)
16	85-50-0096	1	BALL JOINT ARM
17	NC01-69-0423	2	SPRING PIN 3/16" X 1 1/4"
18	NC01-96-0010	2	NYLON NUT HEX. ZINC 5/16-18
19	NC02-22-0008	3	WASHER ZINC 5/16"
20	NC02-32-0011	1	LOCK WASHER ZINC 5/16"
21	21-01-0950	2	FLAT WASHER IOGA 1.005" DIA X 25/64"
22	NC01-00-0381	4	AIRCRAFT BOLT 1/4-28 X 3/16" X .656 L.T.Z. (AN4-5A)
23	86-50-0140	1	GEARBOX BRACKET
24	86-50-0145	1	CRANK HOLDER

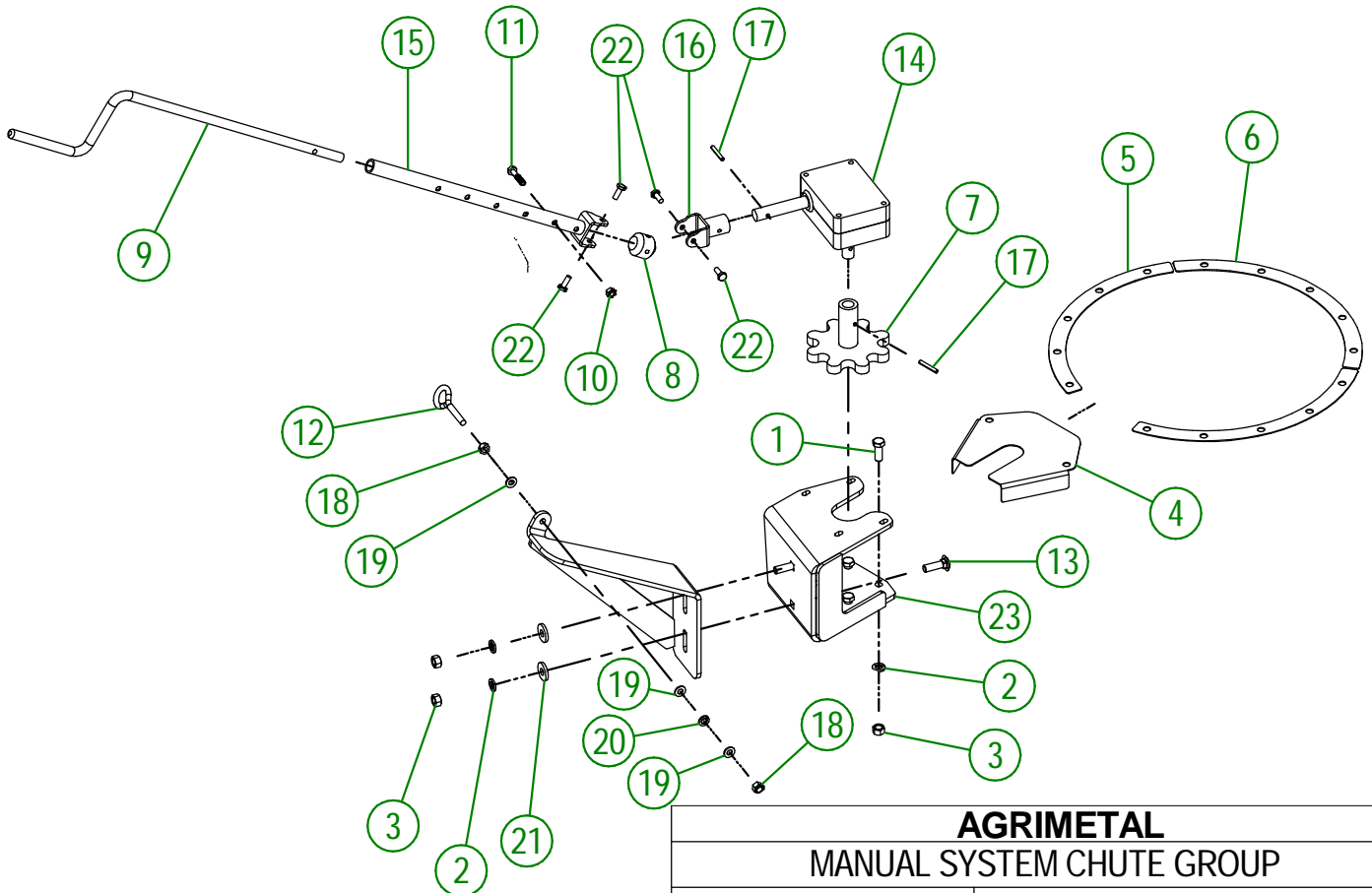

AGRIMETAL	
MANUAL SYSTEM CHUTE GROUP	
CREATION : 23/04/19	ASSEMBLY : 86-57-0131
REVISION : 23/08/22	AUTHOR : F.HÉLIE

#	PART #	QTY	TITLE
1	NC13-33-0304	1	STICKER YUKON
2	NC13-33-0024	4	STICKER GREASE HERE
3	NC13-33-0183	1	STICKER CAUTION OPERATION MANUAL
4	NC13-33-0280	1	STICKER SHEAR BOLT
5	NC13-33-0189	1	STICKER DANGER (PERSON AND CHAIN DRIVE)
6	NC13-33-0274	1	STICKER DANGER
7	NC13-33-0035	2	STICKER AGRIMETAL
8	NC13-33-0322	1	STICKER 2048
9	NC13-33-0317	1	STICKER GREASE DRIVE LINE TELESCOPIC SHAFT
10	NC13-33-0192	2	STICKER (PROJECTION RISK)
11	NC13-33-0186	2	STICKER (DANGER)
12	NC13-33-0005	1	STICKER MAXIMUM 540 RPM
13	NC13-33-0187	1	STICKER DANGER (PTO AND PERSON)
14	NC13-33-0283	1	STICKER DANGER (PERSON AND CHAIN DRIVE)

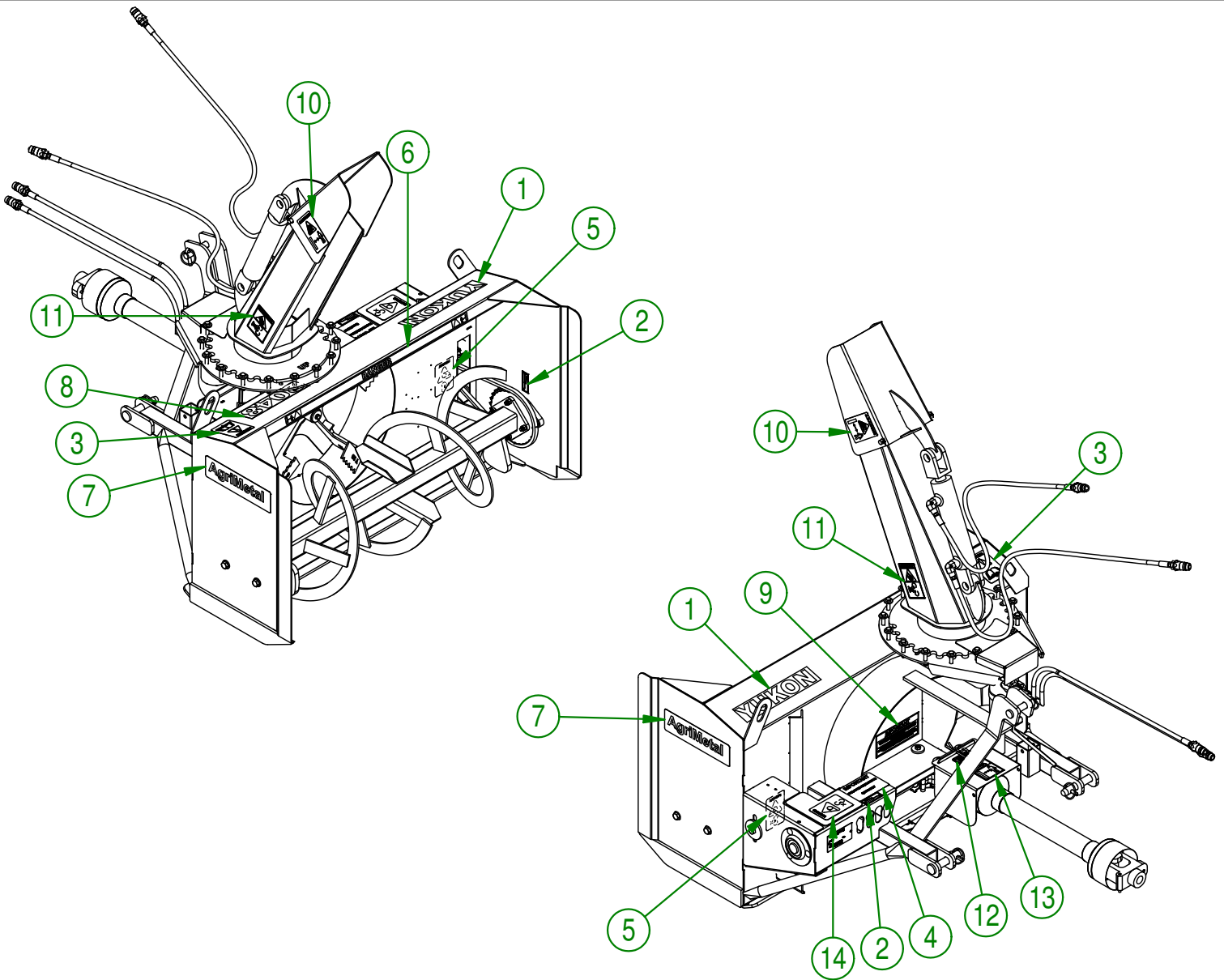

AGRIMETAL	
YUKON 2048	
CREATION : 11/12/18	ASSEMBLY : 86-99-0015
REVISION : 27/05/19	AUTHOR : J.KABWE Page 22 de 22