

AgriMetal

PARTS LIST

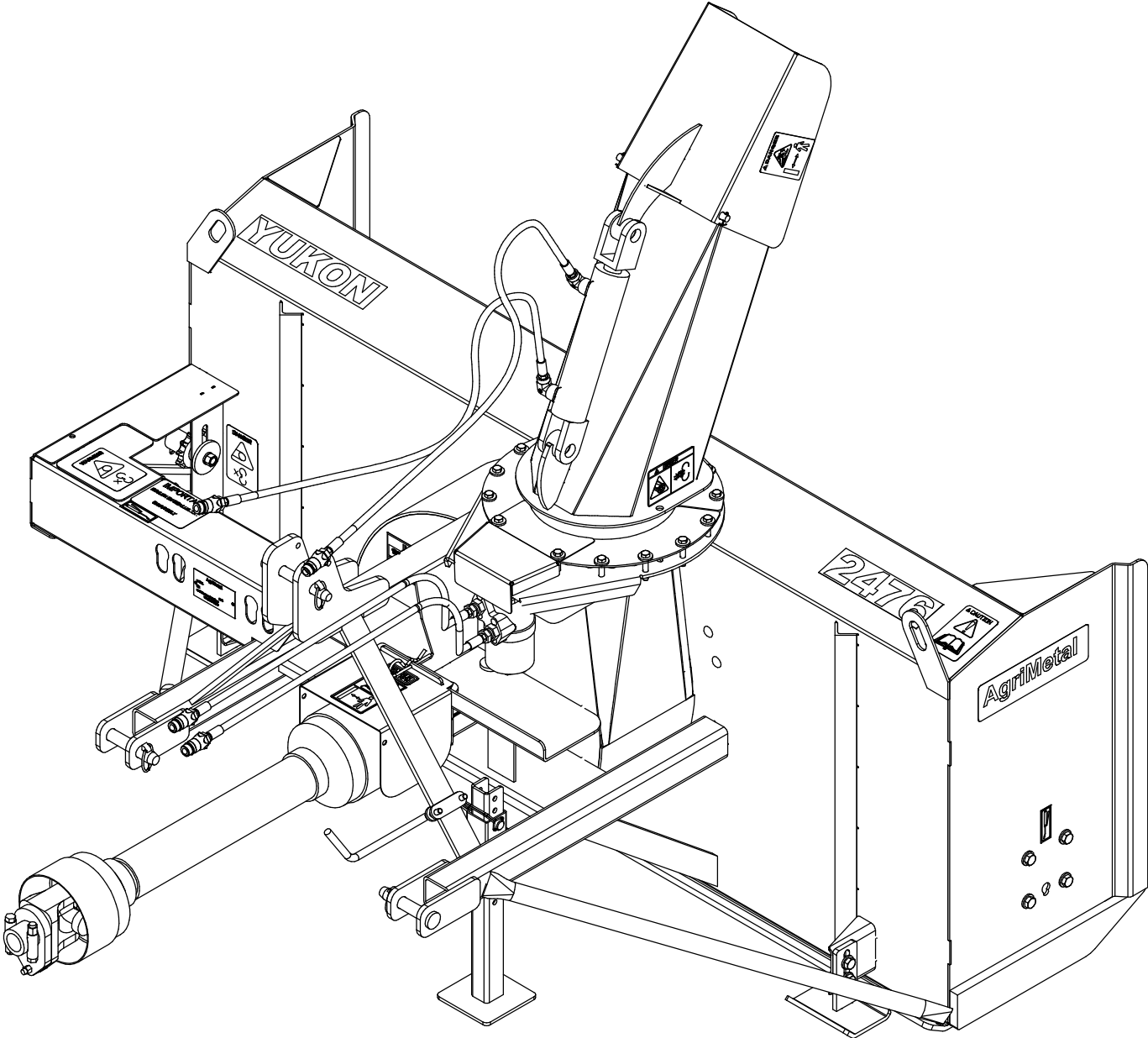

YUKON 2476

#	PART #	Qty	TITLE
1	85-57-0065	1	FRAME
2	80-50-0093	1	STAND
3	85-20-0025	2	3 POINT PIN
4	NC01-69-1100	3	LINCH PIN 3/8"
5	48-20-0075	1	3 POINT PIN
6	25-55-0710	1	SERIAL NUMBER PLATE
7	NC01-69-1306	1	LOCKING PIN 3/8" X 2 1/2" LG

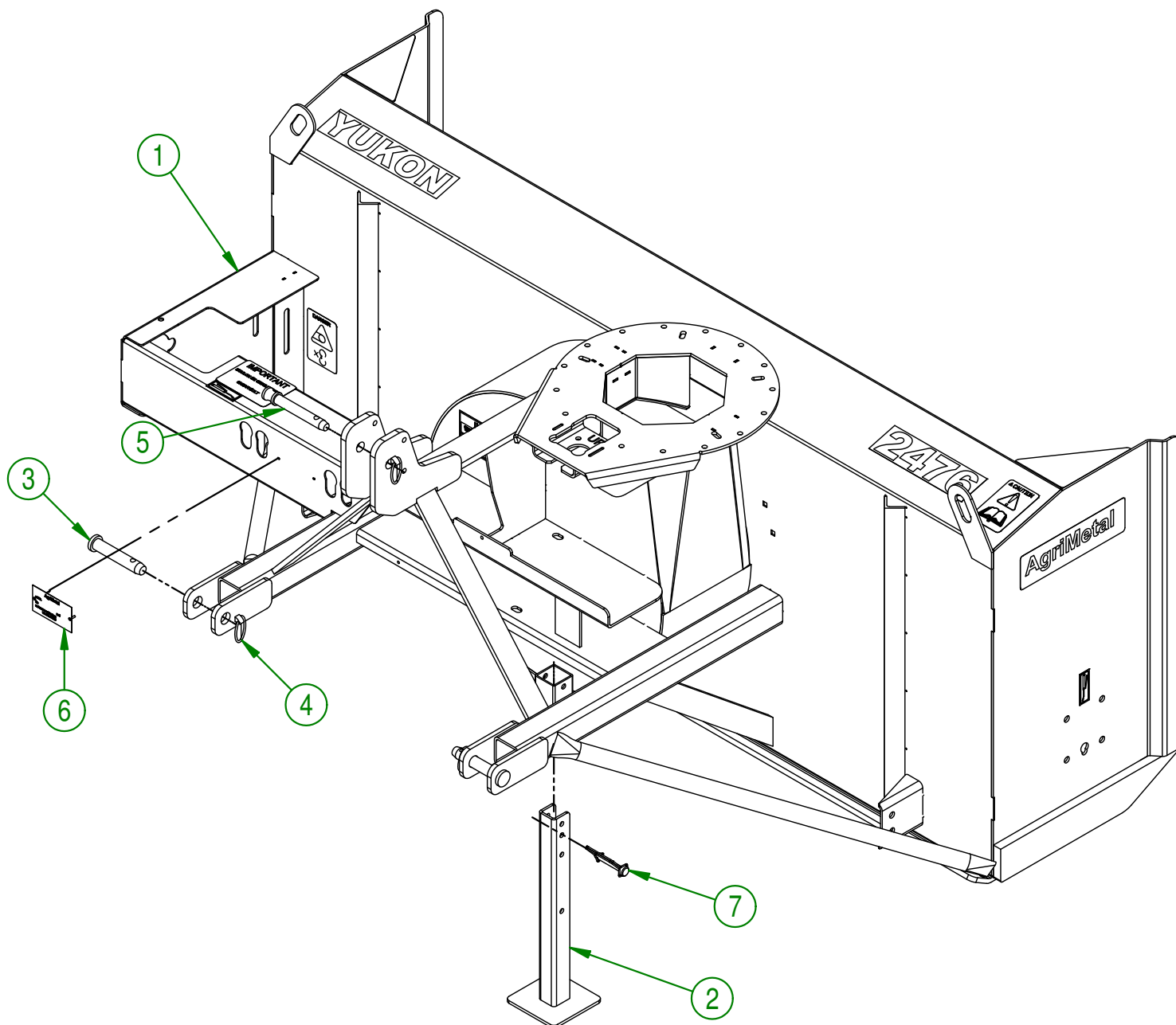

AGRIMETAL
FRAME GROUP.

CREATION : 11/05/17
REVISION : 20/12/18

ASSEMBLY : **85-57-0010**

AUTHOR : J.KABWE

Page 1 de 26

85-57-0020

#	PART #	Qty	TITLE
1	85-55-0035	1	GEARBOX T281A(281.875W/SLEEVE 267.7002 I 3/8
2	82-34-0030	1	PTO SHAFT T40
3	NC01-25-0132	4	HEX.BOLT GR5 NC ZINC 3/8-16 X 5 1/2"
4	85-04-0165	8	WASHER
5	NC01-93-0011	4	LOCK NUT 3/8-16
6	NC01-65-0104	1	IMPELLER KEY
7	85-57-0400	1	OPERATION MANUAL

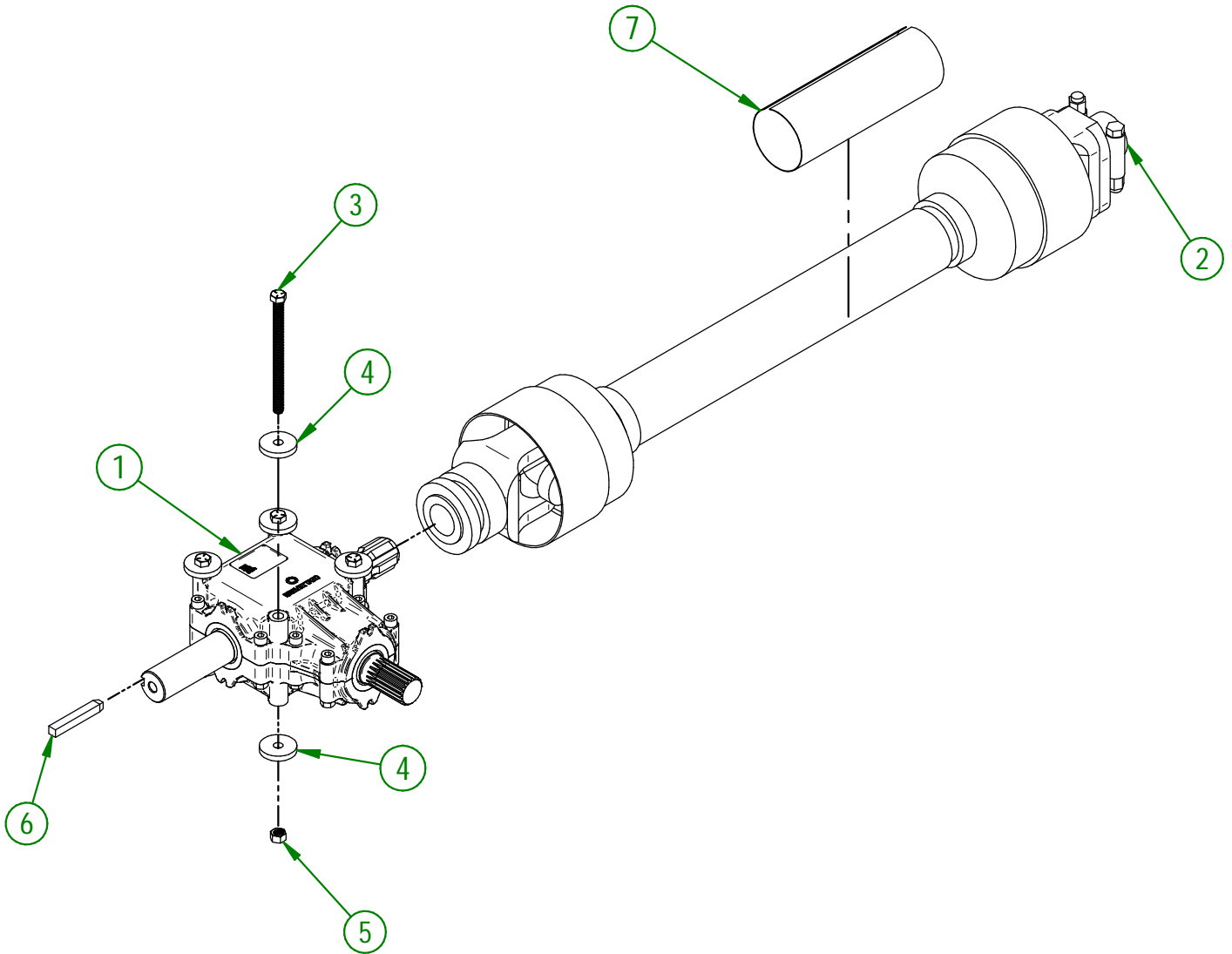

AGRIMETAL
GEARBOX GROUP.

CREATION : 11/05/17
REVISION : 18/12/25

ASSEMBLY : **85-57-0020**
AUTHOR : J.KABWE

#	PART #	Qty	TITLE
1	85-50-0010	1	IMPELLER
2	NC02-32-0012	1	LOCK WASHER ZINC 3/8"
3	NC01-33-0116	1	HEX BOLT. GR2 NC F.L. Z 3/8-16 X 1-1/2
4	NC02-44-0116	2	SOCKET CAP SCREW T. RON 3/8-16 X 3/8 UNBRAKO

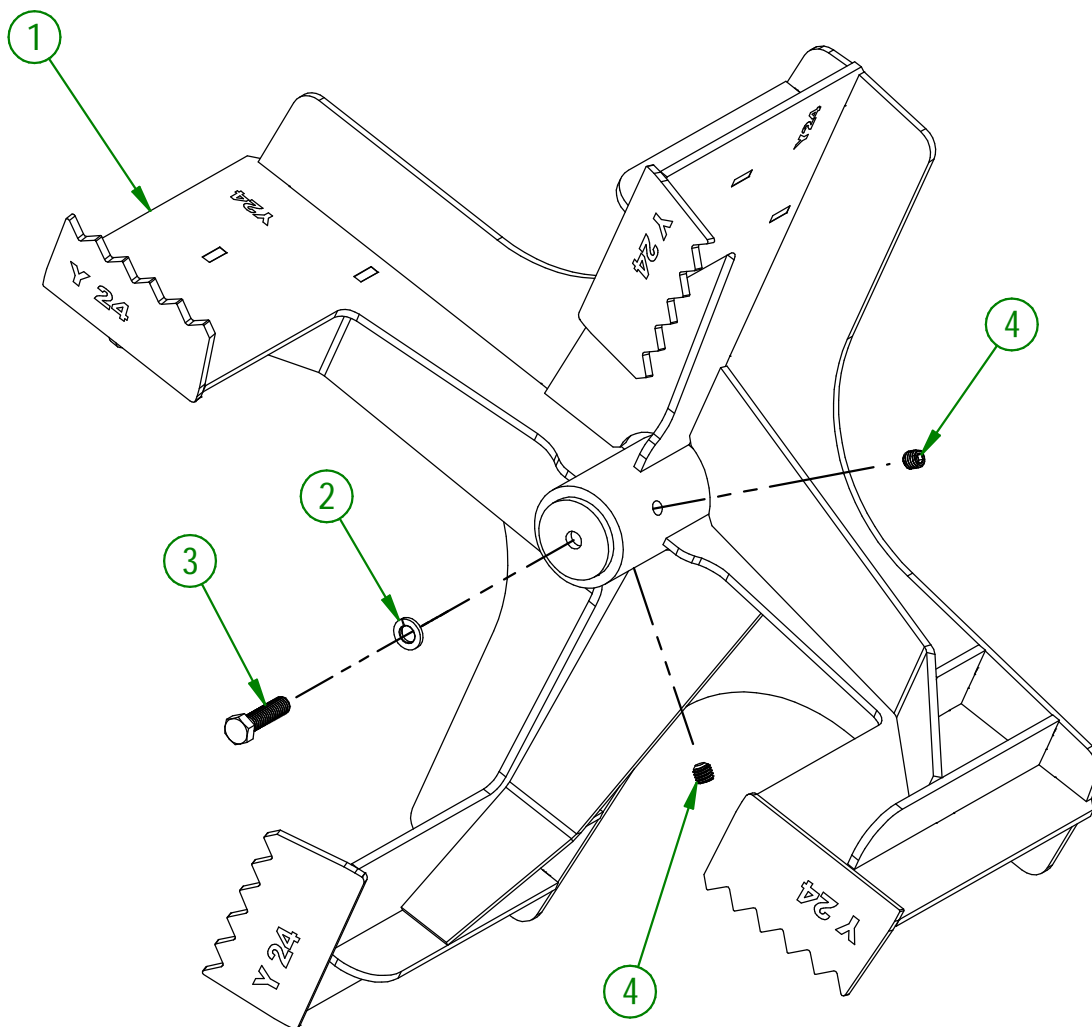

AGRIMETAL	
IMPELLER GROUP	
CREATION : 11/05/17	ASSEMBLY : 85-57-0000
REVISION : 17/02/22	AUTHOR : F.HÉLIE

85-57-0050

#	PART #	Qty	TITLE
1	85-04-0060	1	IMPELLER DOOR
2	NC01-04-0107	3	CARR. BOLT GR2 ZINC 3/8-16 X 3/4"
3	NC02-32-0012	3	LOCK WASHER ZINC 3/8"
4	NC02-07-0018	3	HEX. NUT ZINC 3/8-16

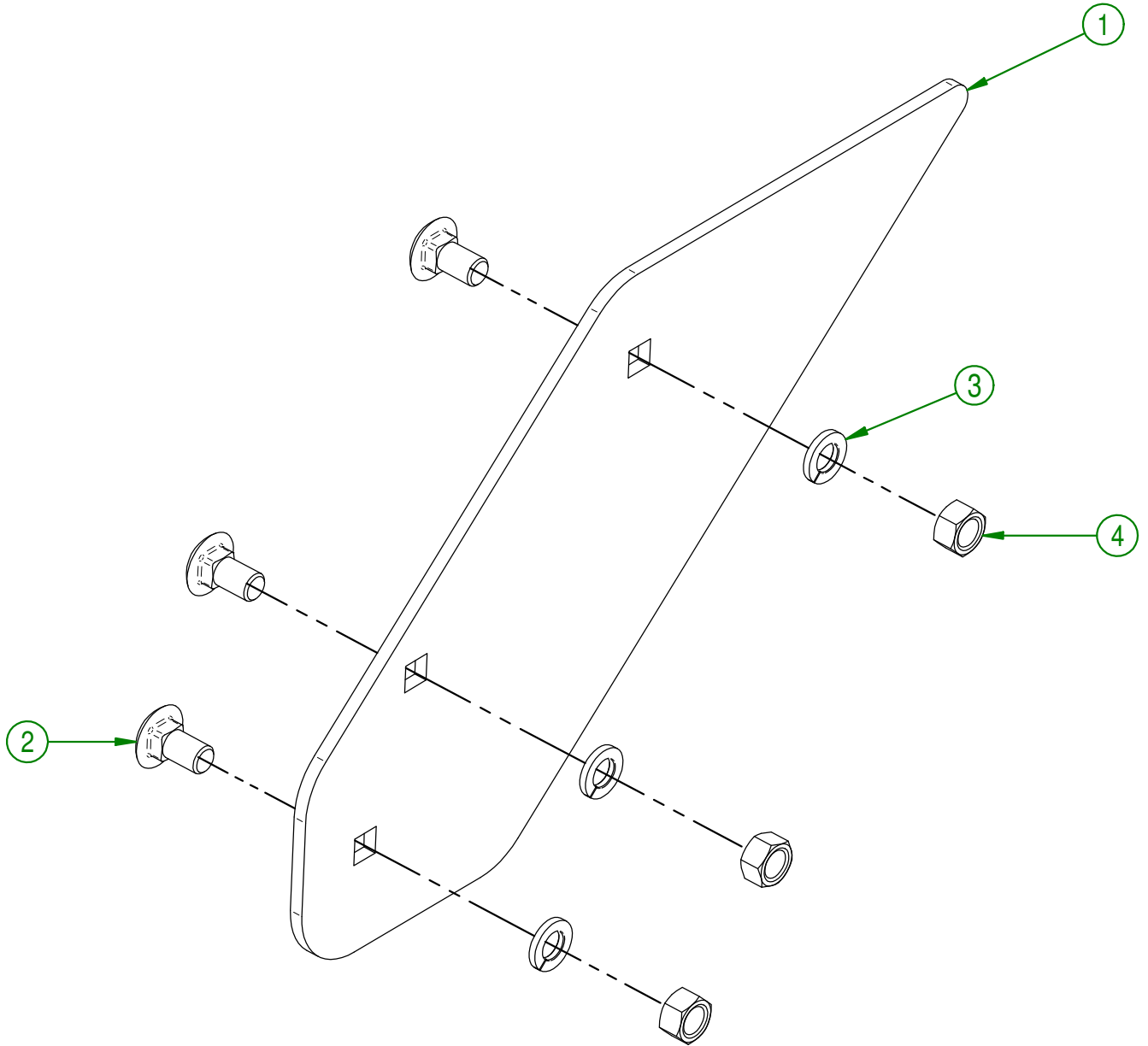

AGRIMETAL	
IMPELLER DOOR GROUP	
CREATION : 11/05/17	ASSEMBLY : 85-57-0050
REVISION : 26/03/18	AUTHOR : J.KABWE Page 4 de 26

#	PART #	Qty	TITLE
1	85-50-0015	1	SPIRAL
2	NC14-75-0160	2	FLANGE BEARING UCF207-20 1 1/4" ID
3	NC01-17-0250	8	HEX. BOLT GR2 ZINC 1/2-13 X 1 3/4"
4	NC02-25-0011	8	WASHER SAE ZINC 17/32 ID
5	NC02-32-0014	8	LOCK WASHER ZINC 1/2"
6	NC02-07-0020	8	HEX. NUT ZINC 1/2-13
7	80-01-1525	1	SPIRAL SHIM
8	NC14-55-0294	1	SPROCKET 60A32H X 1 1/4"Ø + 4 Ø25/64
9	NC01-94-0011	4	JAM NUT 3/8-24
10	NC01-37-0115	4	HEX. BOLT 3/8-24 X 1 1/4"

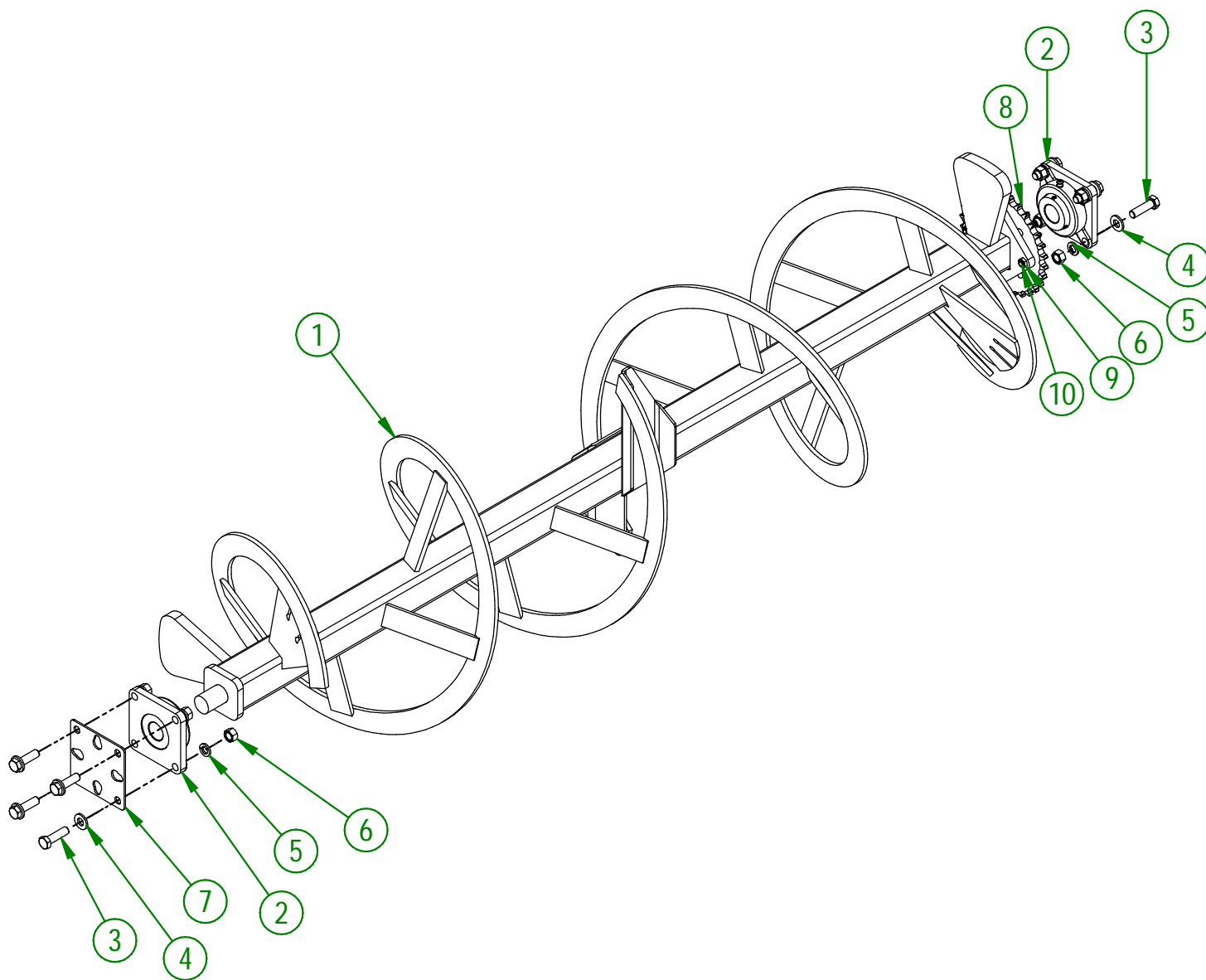

AGRIMETAL	
SPIRAL GROUP	
CREATION : 11/05/17	ASSEMBLY : 85-57-0055
REVISION : 09/12/25	AUTHOR : F.HÉLIE

#	PART #	Qty	TITLE
1	NC14-75-0094	1	PRESSED STEEL FLANGE WITH GREASE FITTING
2	NC14-75-0093	1	PRESSED STEEL FLANGE
3	NC14-75-0164	1	SB207-20 BEARING
4	80-21-0025	1	SPIRAL DRIVE TRAIN BUSHING
5	NC14-55-0293	1	60BI2H SPROCKET
6	85-50-0035	1	SPIRAL DRIVE TRAIN
7	NC01-04-0109	3	CARR. BOLT GR2 ZINC 3/8-16 X 1"
8	NC02-32-0012	3	LOCK WASHER ZINC 3/8"
9	NC02-07-0018	3	HEX. NUT ZINC 3/8-16
10	NC01-17-0063	1	CAP SCREW GR2 NC ZINC 5/16-18 X 1 3/4"
11	NC01-93-0010	1	LOCK NUT ZINC 5/16-18
12	NC01-69-0785	1	STRAIGHT GREASE FITTING 1/4-28
13	85-04-0420	2	WASHER
14	NC01-29-0261	1	HEX. BOLT GR.5 N ZINC 1/2-20 4 1/2"
15	85-21-0000	1	CHAIN TENSIONER BUSHING (SPROCKET)
16	NC14-55-0295	1	SPROCKET 60AI2H
17	85-21-0005	1	CHAIN TENSIONER BUSHING (SPROCKET)
18	NC02-32-0014	1	LOCK WASHER ZINC 1/2"
19	NC02-10-0020	1	HEX. NUT ZINC 1/2-20
20	85-37-0005	1	# 60 HD CHAIN

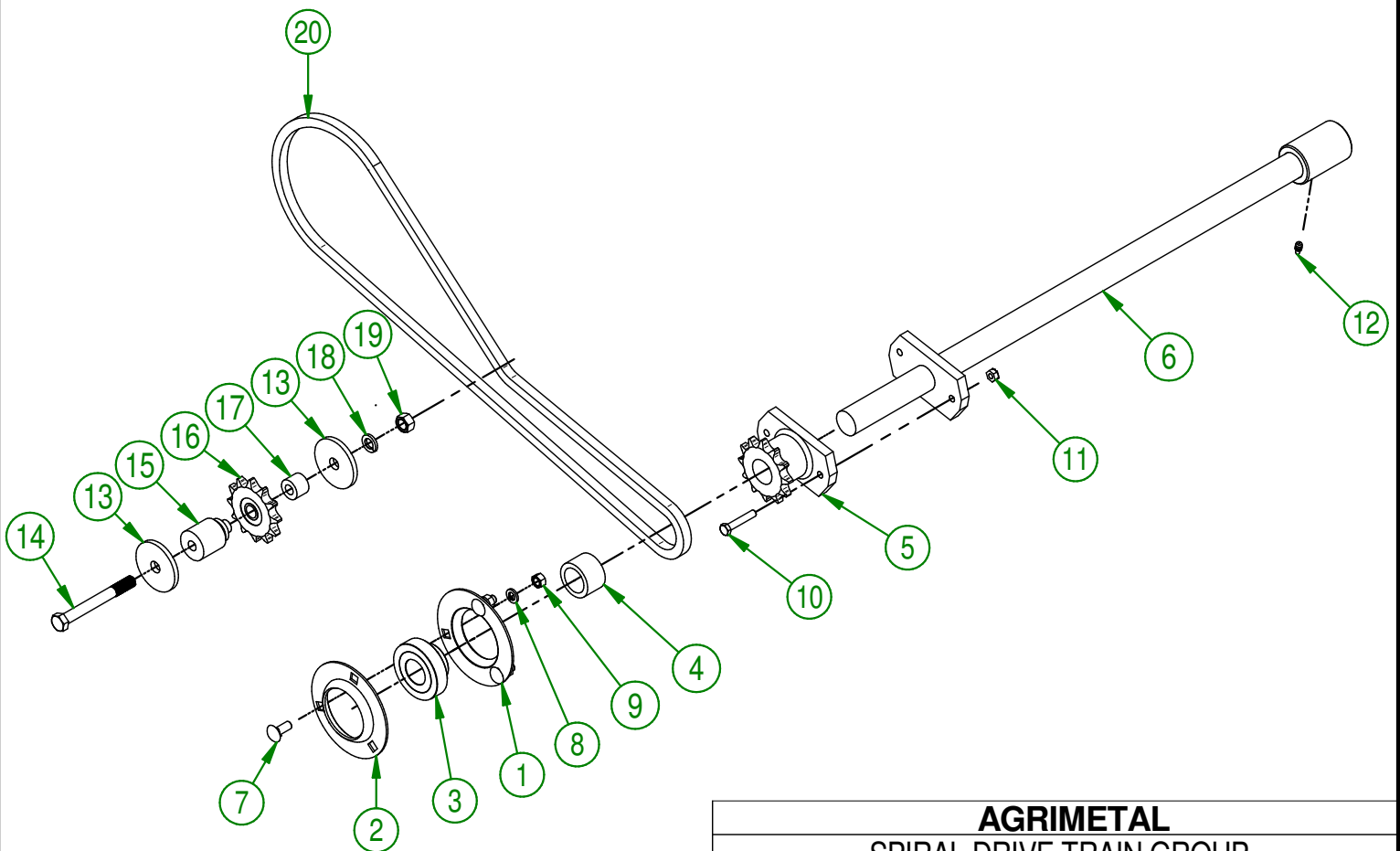
**AGRIMETAL****SPIRAL DRIVE TRAIN GROUP**

CREATION : 11/05/17
 REVISION : 05/05/21

ASSEMBLY : **85-57-0025**
 AUTHOR : J.KABWE

85-57-0035

#	PART #	Qty	TITLE
1	85-57-0036	1	SPIRAL DRIVE TRAIN DOOR GROUP. "STICKER INCLUDED"
2	NC02-29-0028	1	PLASTIC WASHER 13/16" OD X 13/32" ID
3	NC02-26-1525	2	WASHER INOX .406" D.I. X .815" D.E.
4	NC01-25-0114	1	HEX. BOLT GR5 ZINC 3/8-16 X 1"
5	NC01-96-0011	1	NYLON NUT 3/8-16

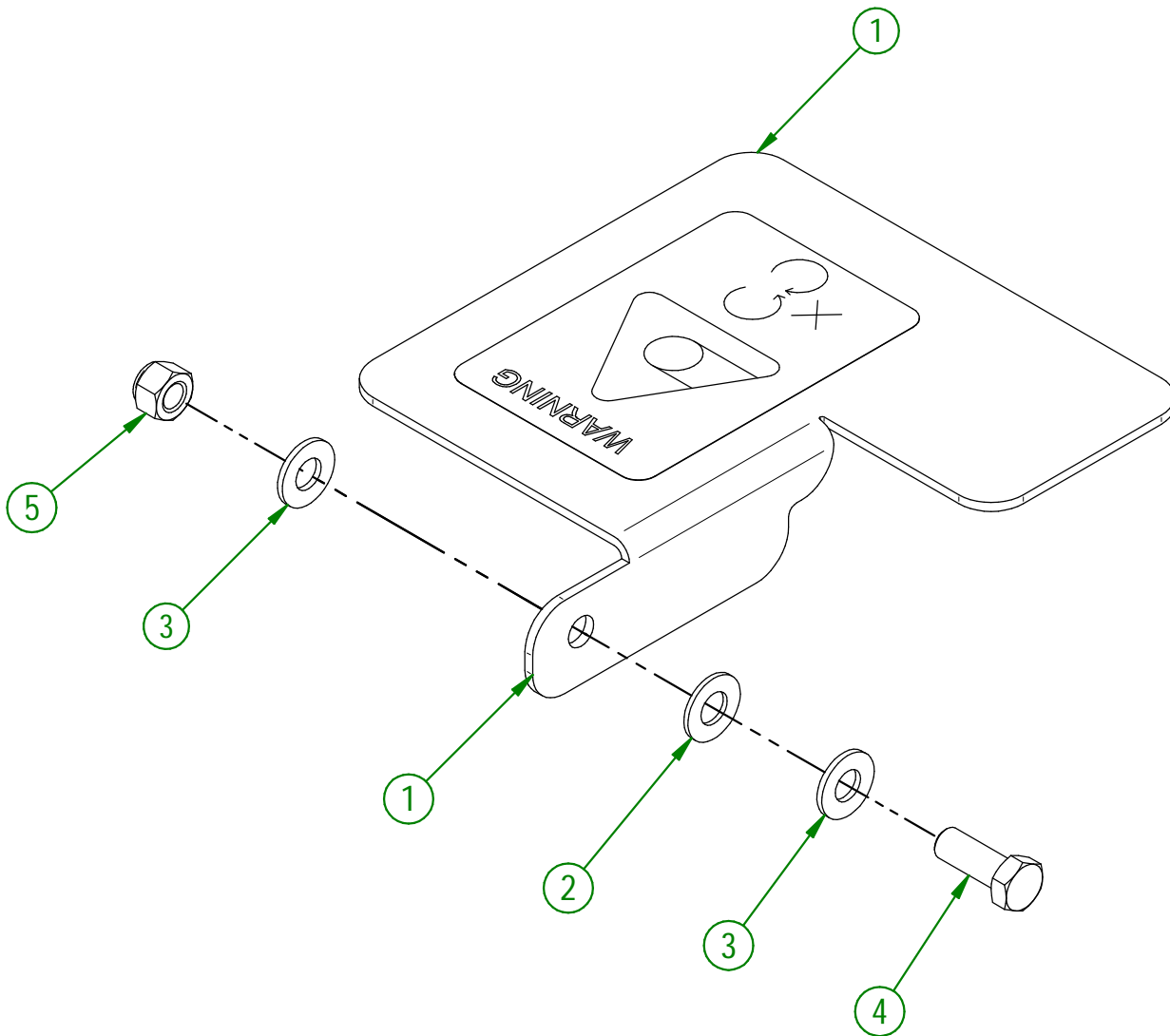

AGRIMETAL	
SPIRAL DRIVE TRAIN DOOR GROUP	
CREATION : 11/05/17	ASSEMBLY : 85-57-0035
REVISION : 23/12/25	AUTHOR : J.KABWE

#	PART #	Qty	TITLE
1	85-57-0041	1	PTO SHAFT GUARD GROUP "STICKER INCLUDED"
2	80-41-0135	1	PTO GUARD STEEL CABLE
3	NC01-64-0005	2	OVAL SLEEVE (ALUMINUM)
4	NC01-63-0027	1	HAIRPIN COTTER

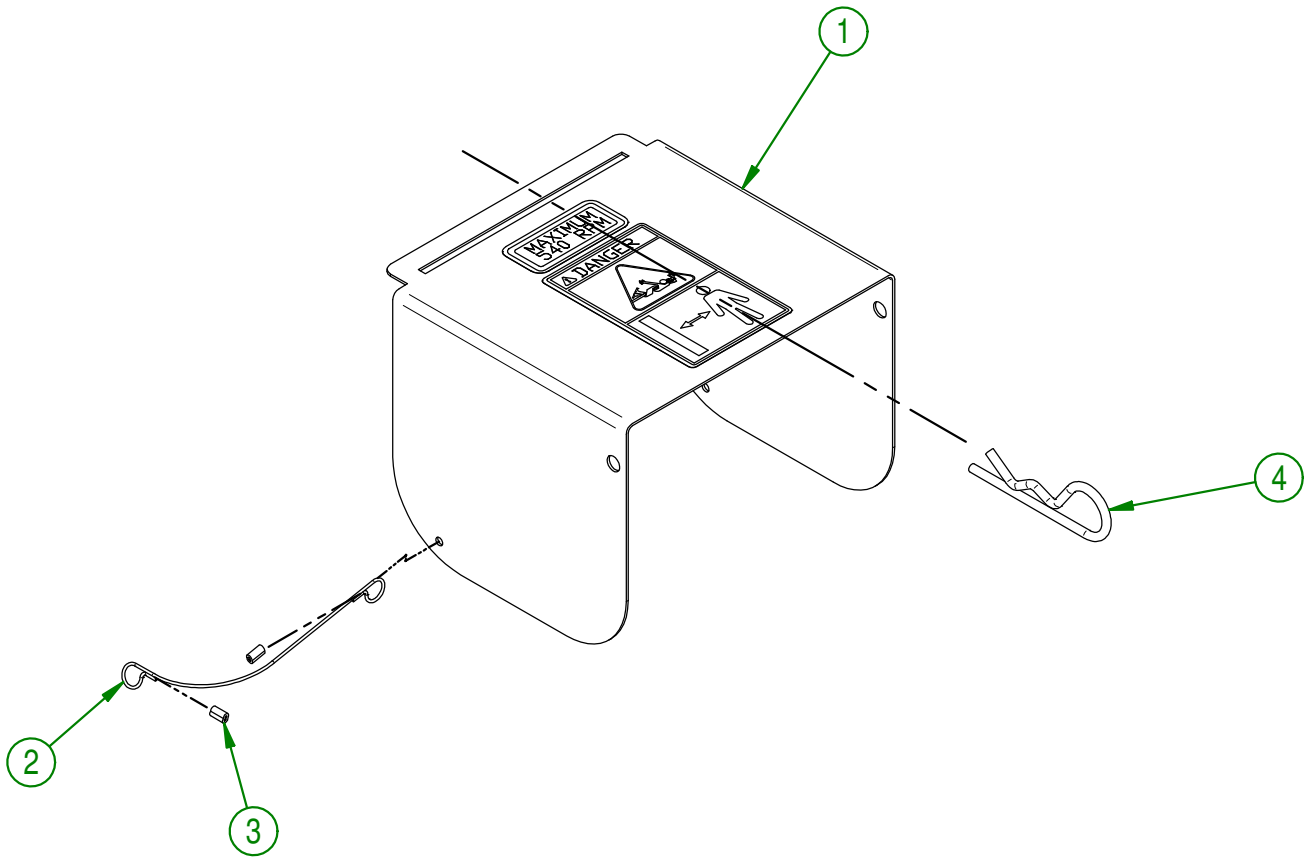

AGRIMETAL	
PTO GUARD GROUP.	
CREATION : 11/05/17	ASSEMBLY : 85-57-0040
REVISION : 07/03/19	AUTHOR : J.KABWE Page 8 de 26

#	PART #	Qty	TITLE
1	85-50-0025	2	SKATE
2	NC02-25-0011	8	WASHER SAE ZINC 17/32 ID
3	NC01-17-0249	4	HEX. BOLT GR2 ZINC 1/2-13 X 1 1/2"
4	NC02-32-0014	4	LOCK WASHER ZINC 1/2"
5	NC02-07-0020	4	HEX. NUT ZINC 1/2-13

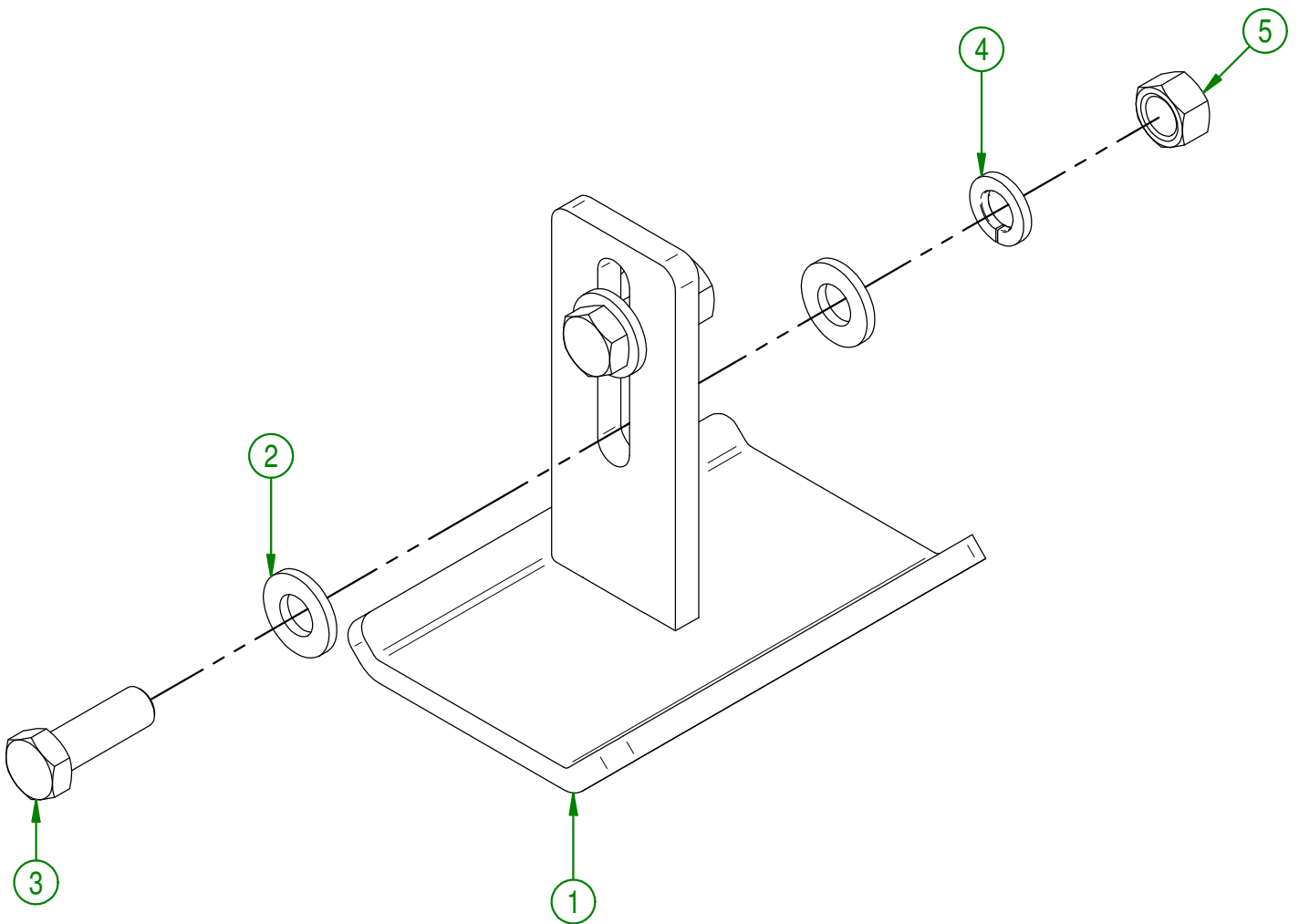

AGRIMETAL	
ADJUSTABLE SKATE GROUP (LEFT & RIGHT) (OPTION)	
CREATION : 11/05/17	ASSEMBLY : 85-57-0170
REVISION : 19/12/17	AUTHOR : J.KABWE Page 9 de 26

#	PART #	Qty	TITLE
1	85-57-0180	1	CHUTE GROUP
2	85-57-0060	1	HYDRAULIC MOTOR GROUP

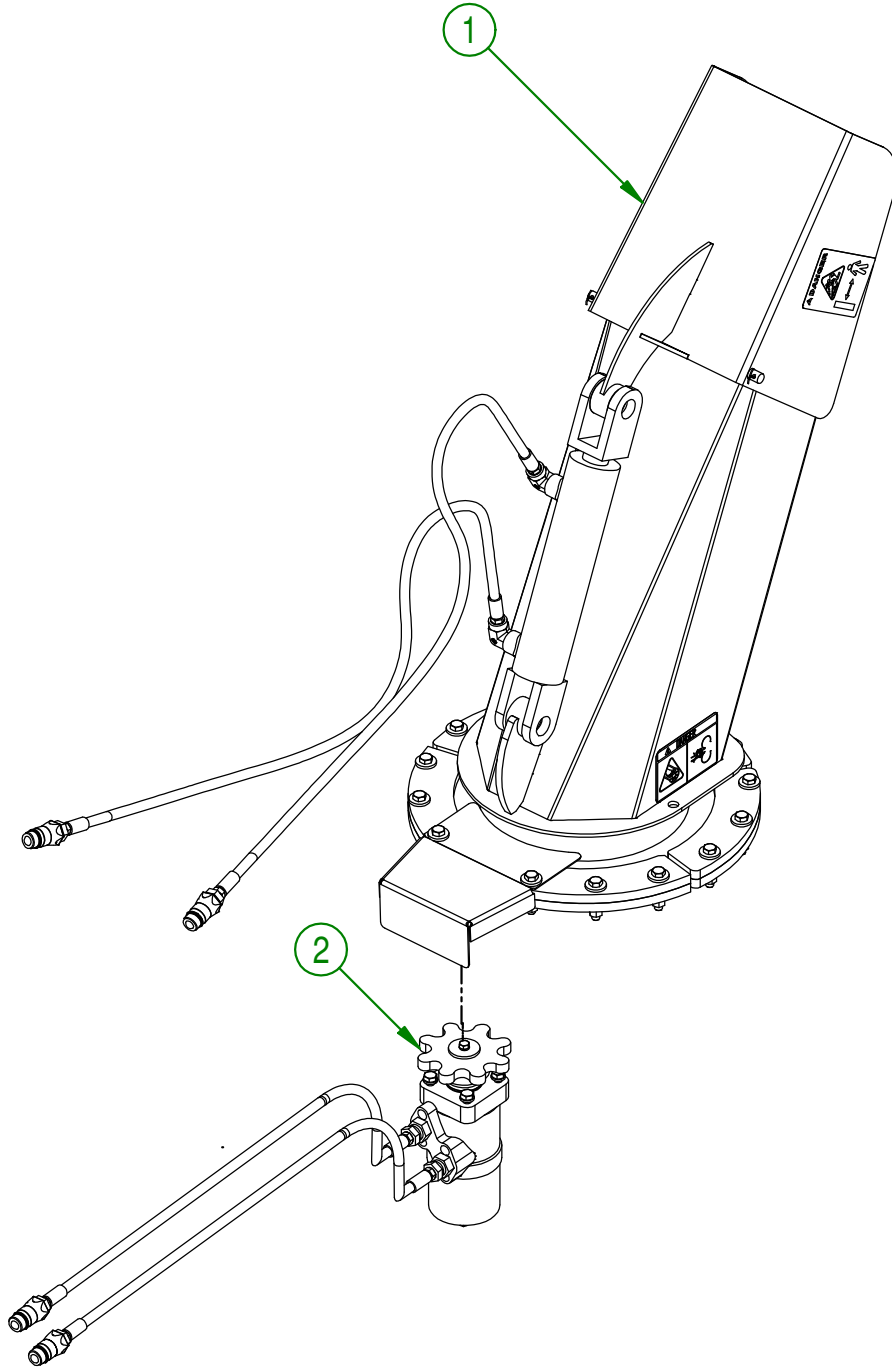

AGRIMETAL	
HYDRAULIC CHUTE GROUP	
CREATION : 11/05/17	ASSEMBLY : 85-57-0160
REVISION : 26/03/18	AUTHOR : F.HÉLIE Page 10 de 26

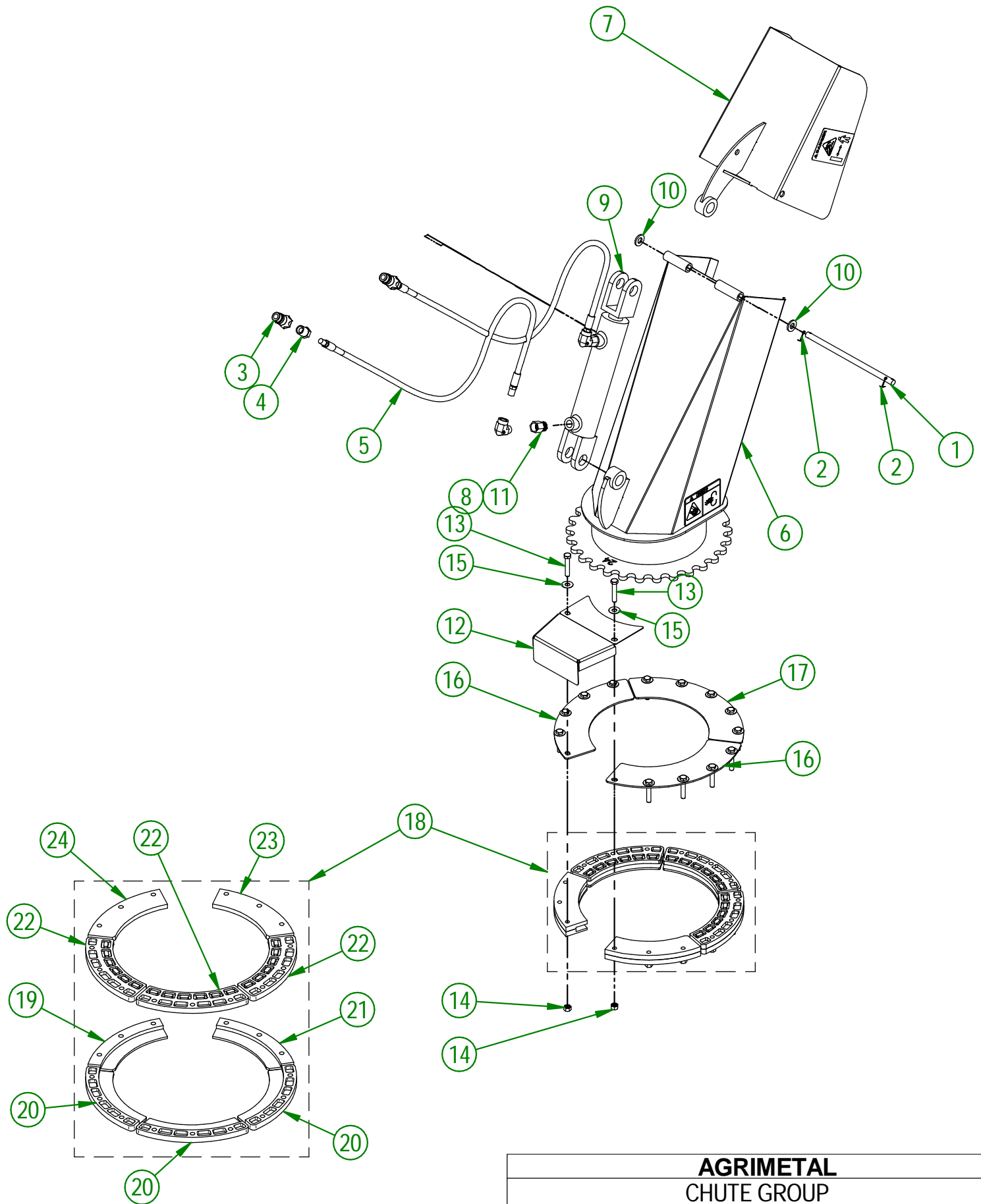

AGRIMETAL
CHUTE GROUP

CREATION : 09/06/17
 REVISION : 05/11/24

ASSEMBLY : **85-57-0180**
 AUTHOR : F.HÉLIE

85-57-0180

#	PART #	Qty	TITLE
1	85-13-0015	1	PIVOT
2	NC01-69-0139	2	COTTER PIN ZINC 1/8" X 3/4"
3	NC13-45-0369	2	QUICK COUPLER 1/2-14 NPTF
4	NC13-45-0153	2	HEX. REDUCER 1/4 NPT X 1/2 NPT
5	NC17-02-0329	2	HYDRAULIC HOSE (87" LG)
6	85-57-0110	1	CHUTE GROUP DOWN SECTION
7	85-57-0115	1	CHUTE GROUP UP SECTION
8	NC13-45-0038	2	ELBOW 90 3/8 FEM. NPT X 3/8 MALE NPT
9	NC13-45-0404	1	HYDRAULIC CYLINDER 6"
10	NC02-25-0011	2	WASHER SAE ZINC 17/32 ID
11	NC13-45-0268	2	UNION RIGHT MALE SAE6 ORING FEM.NPT
12	82-01-3005	1	SPROCKET GUARD
13	NC01-25-0118	15	HEX. BOLT GR5 NC ZINC 3/8-16 X 2"
14	NC01-93-0011	15	LOCK NUT 3/8-16
15	NC02-22-0010	15	WASHER 13/32" ID
16	82-01-0965	2	BRACE
17	82-01-0955	1	BRACE
18	84-57-1325	1	CHUTE GUIDE GROUP

84-57-1325

#	PART #	Qty	TITLE
19	46-42-0107	1	CHUTE GUIDE (UNDER)
20	NC17-46-0030	3	CHUTE GUIDE (UNDER)
21	46-42-0106	1	CHUTE GUIDE (UNDER)
22	NC17-46-0029	3	CHUTE GUIDE (TOP)
23	46-42-0101	1	CHUTE GUIDE (TOP)
24	46-42-0102	1	CHUTE GUIDE (TOP)

#	PART #	QTY	TITLE
1	NC14-45-0150	1	HYDRAULIC MOTOR 315
2	48-50-1025	1	HYDRAULIC ENGINE SPROCKET
3	NC02-32-0012	4	LOCK WASHER ZINC 3/8"
4	NC01-33-0113	4	HEX.BOLT GR8 ZINC 3/8-16 X 3/4"
5	NC02-22-0009	1	WASHER
6	NC02-32-0010	1	LOCK WASHER ZINC 1/4"
7	NC01-33-0005	1	HEX. BOLT GR8 ZINC 1/4-20 X 7/8"
8	NC13-45-0073	2	STRAIGHT 7/8-14 MALE SAE10 O-RING X 3/8 FEM. TOUR. NPT
9	NC13-45-0369	2	QUICK COUPLER 1/2-14 NPTF
10	80-45-0000	2	HEX. REDUCER 1/4 NPT X 1/2 NPT
11	NC17-02-0328	2	HYDRAULIC HOSE (63" LG)
12	80-13-0100	2	HYDRAULIC RESTRICTOR
13	NC13-45-0378	2	HYDRAULIC RESTRICTOR BUSHING
14	NC17-46-0031	1	HYDRAULIC MOTOR BUSHING
15	NC02-44-0103	2	SET SCREW 5/16-18 X 3/8"

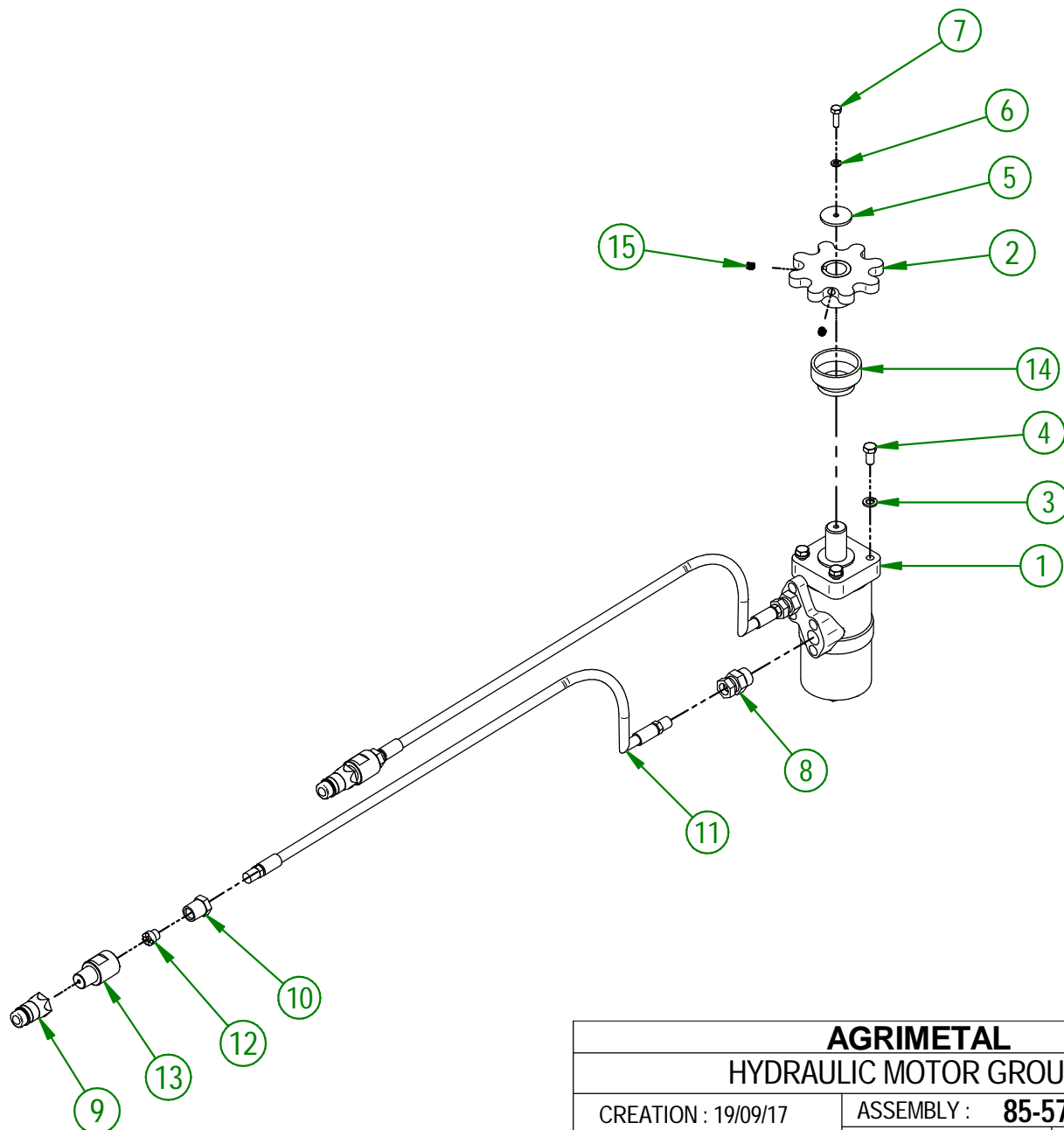

AGRIMETAL	
HYDRAULIC MOTOR GROUP	
CREATION : 19/09/17	ASSEMBLY : 85-57-0060
REVISION : 11/12/25	AUTHOR : J.KABWE

#	PART #	Qty	TITLE
1	84-57-0045	1	CHUTE (9 1/2") GROUP
2	85-57-0060	1	HYDRAULIC MOTOR GROUP

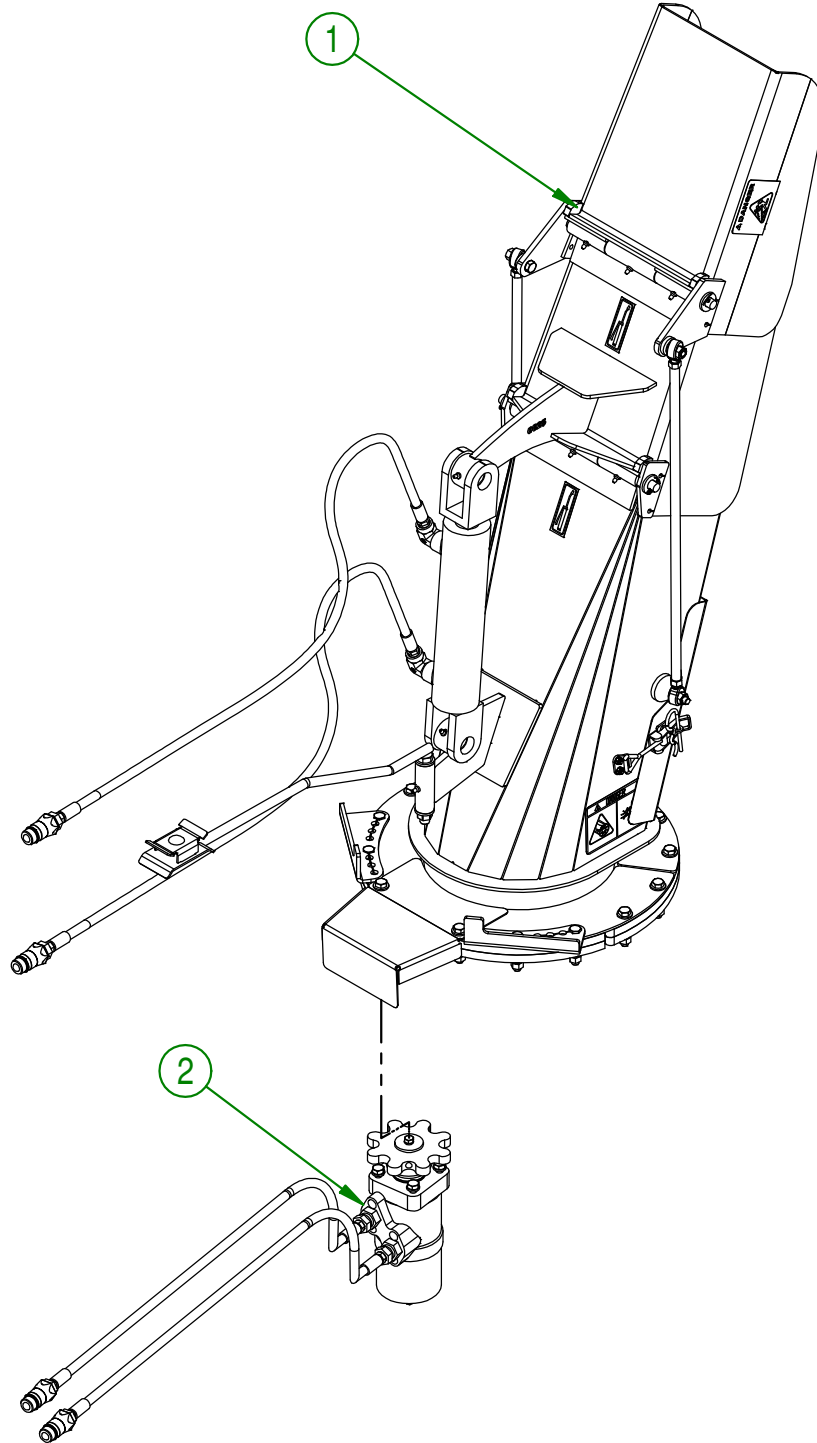

AGRIMETAL	
COMMERCIAL CHUTE GROUP (2 DEFLECTORS)	
CREATION : 11/05/17	ASSEMBLY : 85-57-0165
REVISION : 09/01/19	AUTHOR : Dessin2 Page 14 de 26

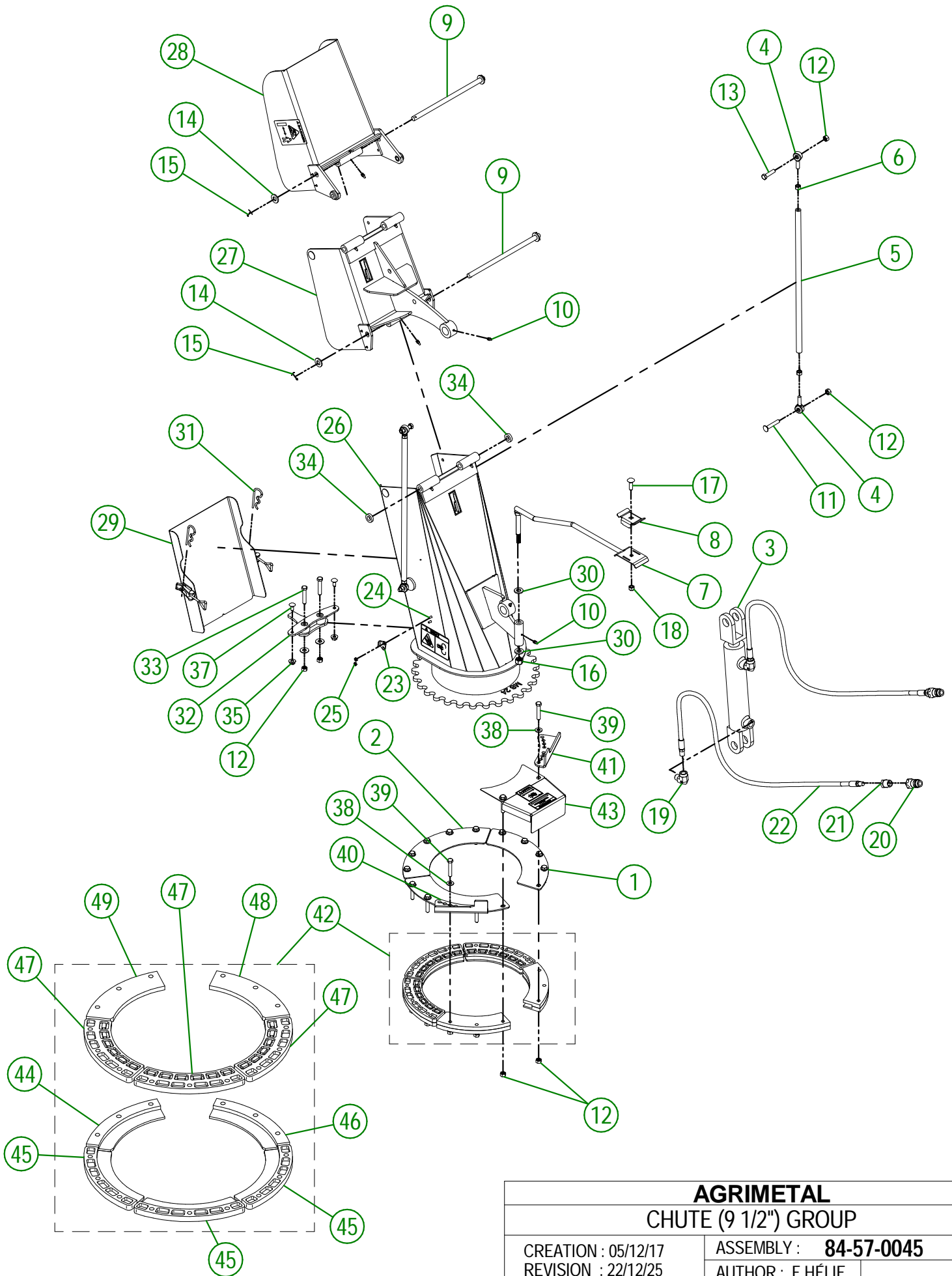

AGRIMETAL
CHUTE (9 1/2") GROUP

CREATION : 05/12/17
 REVISION : 22/12/25

ASSEMBLY : **84-57-0045**
 AUTHOR : F.HÉLIE

84-57-0045

#	PART #	Qty	TITLE
1	82-01-0965	2	BRACE
2	82-01-0955	1	BRACE
3	NC13-45-0404	1	HYDRAULIC CYLINDER 6"
4	NC01-67-0304	4	ROD END 3/8-24
5	48-13-0600	2	CHUTE ROD (DOUBLE)
6	NC02-10-0018	4	NUT 3/8-24
7	48-50-1030	1	HYDRAULIC HOSE SUPPORT
8	48-01-7530	1	HYDRAULIC HOSE SUPPORT
9	82-20-0250	2	PIVOT
10	NC01-69-0785	9	STRAIGHT GREASE FITTING 1/4-28
11	NC01-07-0113	2	CARR. BOLT GR5 ZINC 3/8-16 X 2" LG
12	NC01-93-0011	21	LOCK NUT 3/8-16
13	NC01-25-0116	2	HEX. BOLT GR5 ZINC 3/8-16 X 1 1/2"
14	NC02-25-0011	4	WASHER SAE ZINC 17/32 ID
15	NC01-69-0139	4	COTTER PIN ZINC 1/8" X 3/4"
16	NC01-96-0014	1	NYLON-INSERT LOCKNUT ZINC 1/2-13
17	NC01-07-0110	1	CARR. BOLT GR5 ZINC 3/8-16 X 1 1/4"
18	NC01-96-0011	1	NYLON NUT 3/8-16
19	NC13-45-0038	2	ELBOW 90 3/8 FEM. NPT X 3/8 MALE NPT
20	NC13-45-0369	2	QUICK COUPLER 1/2-14 NPTF
21	NC13-45-0153	2	HEX. REDUCER 1/4 NPT X 1/2 NPT
22	NC17-02-0329	2	HYDRAULIC HOSE (87" LG)
23	NC01-63-0052	2	ADJUSTABLE LATCH (STRIKE)
24	NC02-40-0080	4	MACHINE SCREWS SQUARE SOCKET #10-24 X 1/2" LG
25	NC01-96-0006	4	NYLON NUT ZINC 3/16
26	84-57-0300	1	CHUTE (BOTTOM SECTION)
27	82-57-0311	1	CHUTE (MIDDLE SECTION)
28	82-57-0321	1	CHUTE (TOP SECTION)
29	82-57-0352	1	CHUTE DOOR
30	NC02-25-0011	2	WASHER SAE ZINC 17/32 ID
31	NC01-63-0026	2	COTTER PIN ZC 5/32" X 3"
32	84-50-0600	1	STOPPER
33	NC01-37-0118	2	HEX. BOLT GR8 ZINC 3/8-24 X 2"
34	NC13-15-0334	2	PIVOT WASHER
35	NC02-14-0006	2	HEX. NUT SPECIAL FLANGET NC 5/16-18 B GRADE
36	NC02-22-0010	2	WASHER 13/32" ID
37	NC01-07-0056	2	CARR. BOLT GR5 NC ZINC 5/16-18 X 3/4"
38	NC02-26-1525	15	WASHER INOX .406" D.I. X .815" D.E.
39	NC01-25-0118	15	HEX. BOLT GR5 NC ZINC 3/8-16 X 2"
40	84-04-0180	1	ADJUSTABLE STOPPER
41	84-04-0183	1	ADJUSTABLE STOPPER
42	84-57-1325	1	CHUTE GUIDE GROUP
43	84-57-0500	1	SPROCKET GUARD GROUP "STICKER INCLUDED"

84-57-1325

#	PART #	Qty	TITLE
44	46-42-0107	1	CHUTE GUIDE (UNDER)
45	NC17-46-0030	3	CHUTE GUIDE (UNDER)
46	46-42-0106	1	CHUTE GUIDE (UNDER)
47	NC17-46-0029	3	CHUTE GUIDE (TOP)
48	46-42-0101	1	CHUTE GUIDE (TOP)
49	46-42-0102	1	CHUTE GUIDE (TOP)

#	PART #	QTY	TITLE
1	NC14-45-0150	1	HYDRAULIC MOTOR 315
2	48-50-1025	1	HYDRAULIC ENGINE SPROCKET
3	NC02-32-0012	4	LOCK WASHER ZINC 3/8"
4	NC01-33-0113	4	HEX.BOLT GR8 ZINC 3/8-16 X 3/4"
5	NC02-22-0009	1	WASHER
6	NC02-32-0010	1	LOCK WASHER ZINC 1/4"
7	NC01-33-0005	1	HEX. BOLT GR8 ZINC 1/4-20 X 7/8"
8	NC13-45-0073	2	STRAIGHT 7/8-14 MALE SAE10 O-RING X 3/8 FEM. TOUR. NPT
9	NC13-45-0369	2	QUICK COUPLER 1/2-14 NPTF
10	80-45-0000	2	HEX. REDUCER 1/4 NPT X 1/2 NPT
11	NC17-02-0328	2	HYDRAULIC HOSE (63" LG)
12	80-13-0100	2	HYDRAULIC RESTRICTOR
13	NC13-45-0378	2	HYDRAULIC RESTRICTOR BUSHING
14	NC17-46-0031	1	HYDRAULIC MOTOR BUSHING
15	NC02-44-0103	2	SET SCREW 5/16-18 X 3/8"

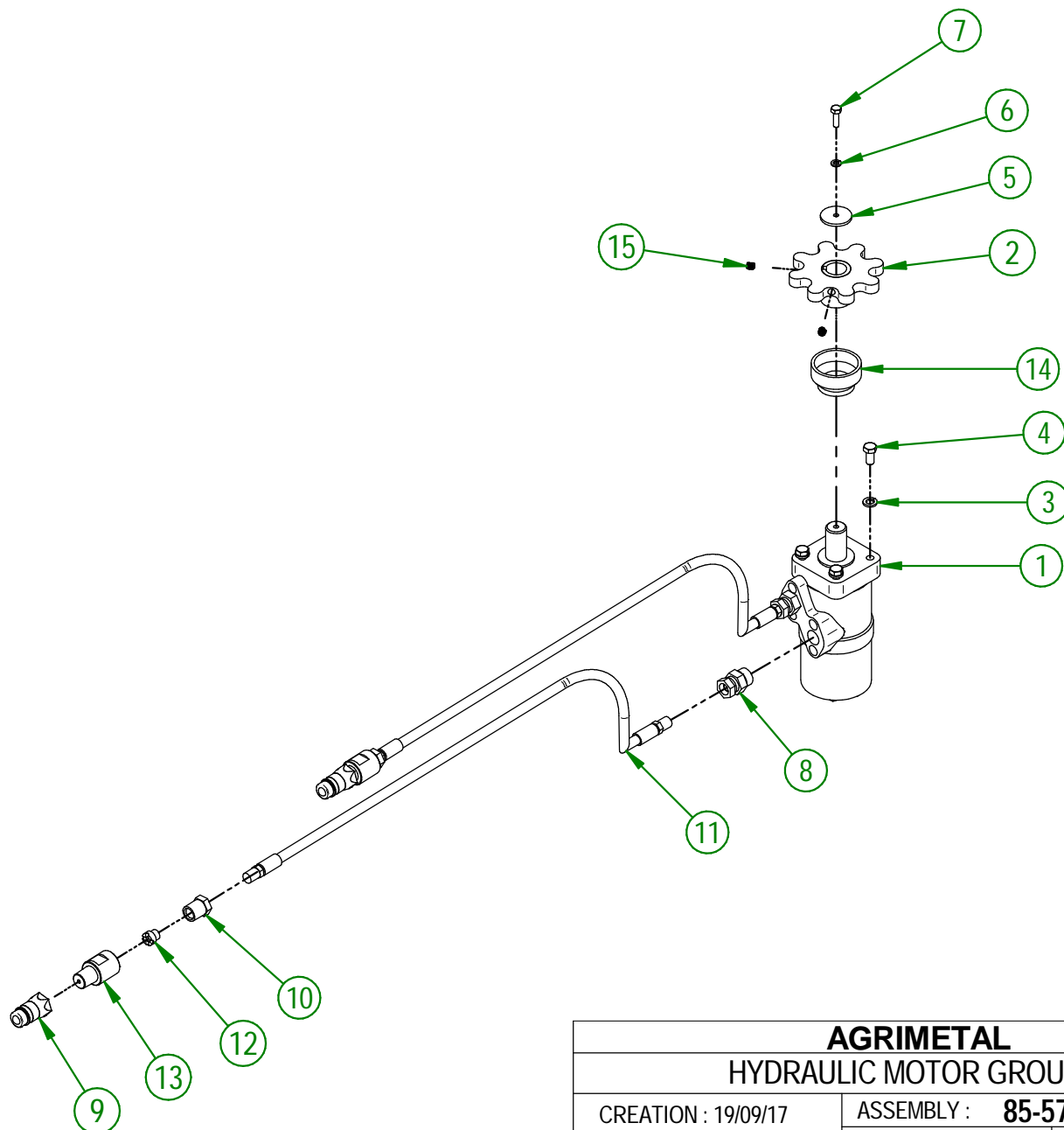

AGRIMETAL	
HYDRAULIC MOTOR GROUP	
CREATION : 19/09/17	ASSEMBLY : 85-57-0060
REVISION : 11/12/25	AUTHOR : J.KABWE

#	PART #	Qty	TITLE
1	85-57-0195	1	MANUAL CHUTE
2	85-57-0060	1	HYDRAULIC MOTOR GROUP

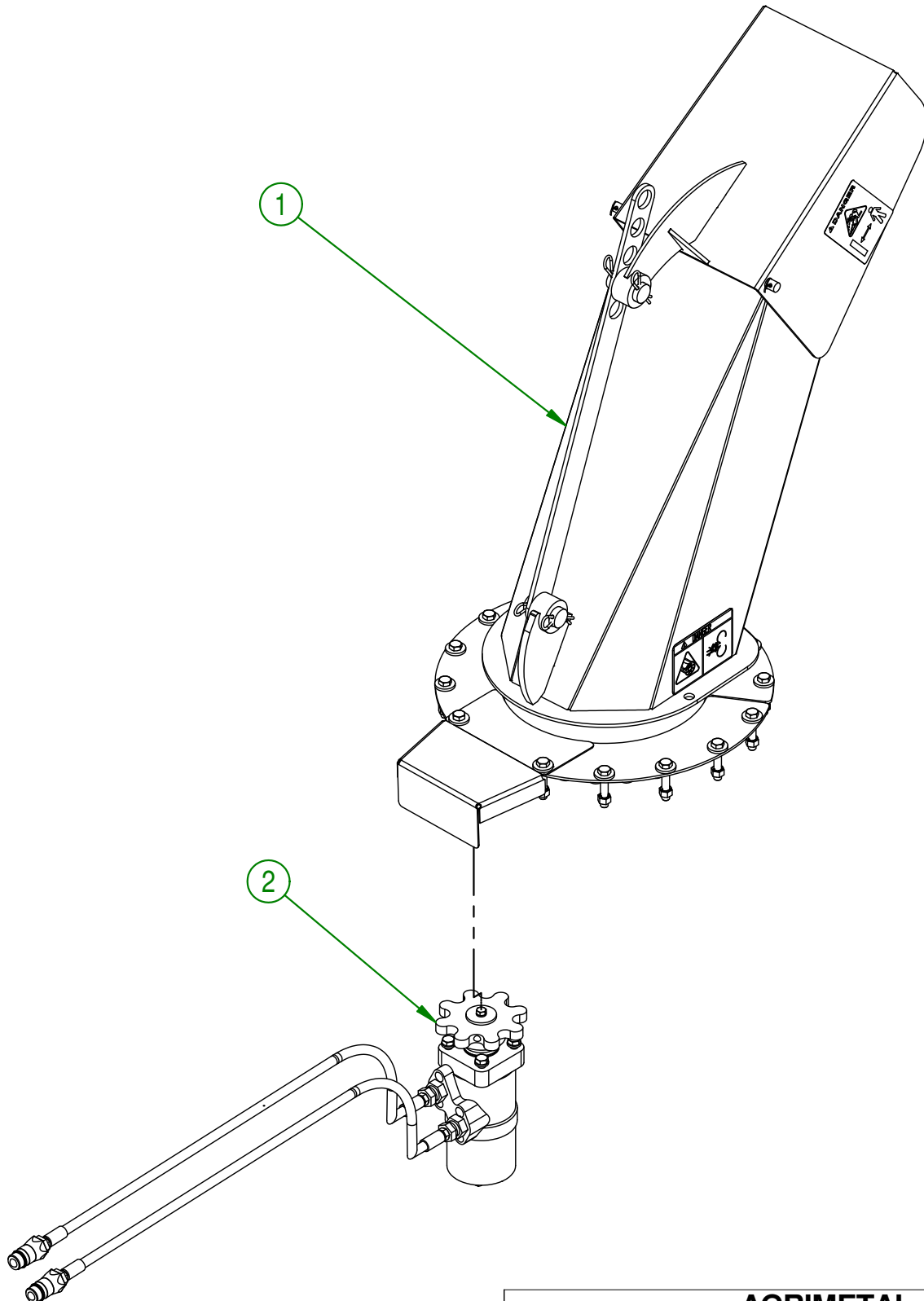

AGRIMETAL	
MANUAL CHUTE WITH HYDRAULIC MOTOR GROUP	
CREATION : 11/05/17	ASSEMBLY : 85-57-0155
REVISION : 25/02/19	AUTHOR : F.HÉLIE Page 18 de 26

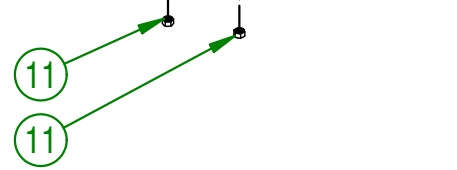
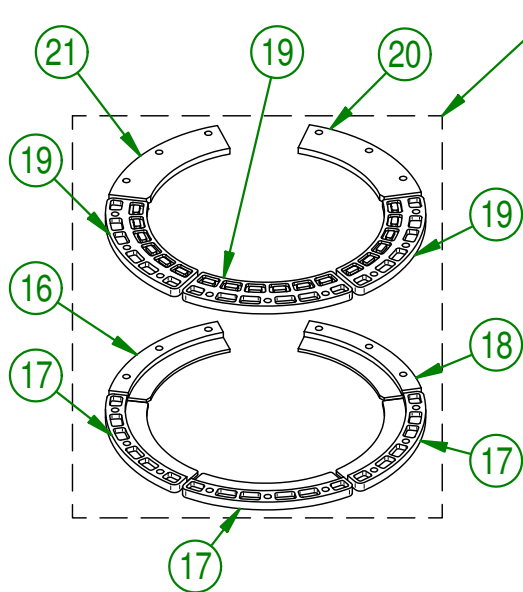
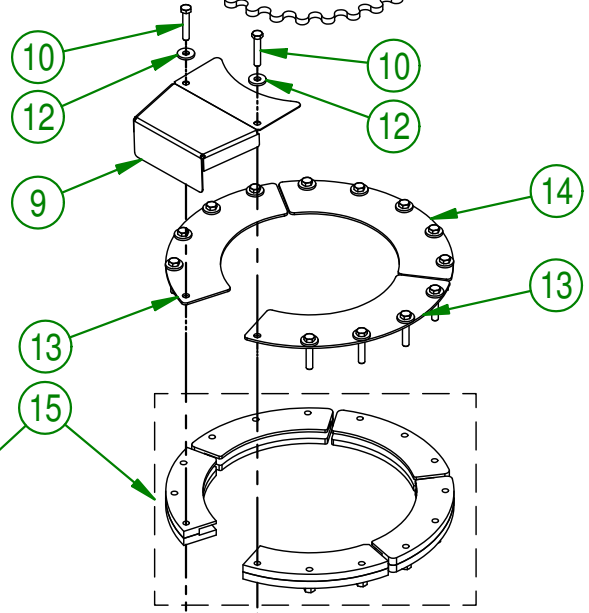
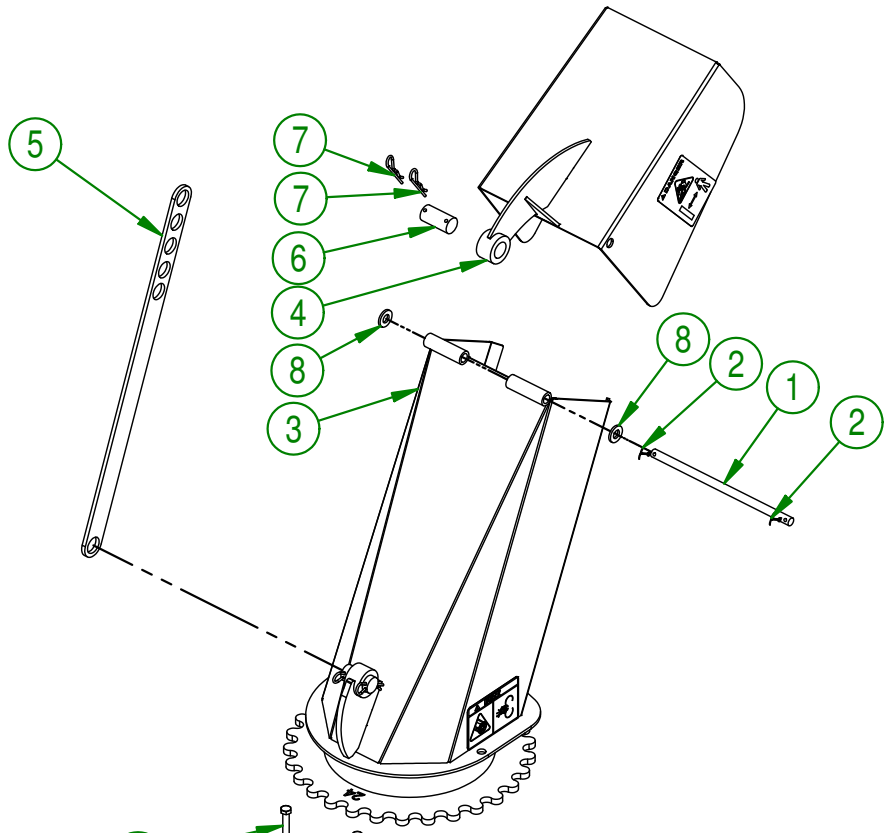

AGRIMETAL	
MANUAL CHUTE	
CREATION : 15/06/17	ASSEMBLY : 85-57-0195
REVISION : 28/08/19	AUTHOR : F.HÉLIE Page 19 de 26

85-57-0195

#	PART #	Qty	TITLE
1	85-13-0015	1	PIVOT
2	NC01-69-0139	2	COTTER PIN ZINC 1/8" X 3/4"
3	85-57-0110	1	CHUTE GROUP DOWN SECTION
4	85-57-0115	1	CHUTE GROUP UP SECTION
5	85-04-0450	1	CHUTE DEFLECTOR ADJUSTABLE PLATE
6	85-13-0480	2	PIVOT CHUTE DEFLECTOR PLATE
7	NC01-63-0015	4	COTTER PIN Z 1/8" X 2 5/8"
8	NC02-25-0011	2	WASHER SAE ZINC 17/32 ID
9	82-01-3005	1	SPROCKET GUARD
10	NC01-17-0118	15	HEX. BOLT GR2 ZINC 3/8-16 X 2"
11	NC01-93-0011	15	LOCK NUT 3/8-16
12	21-01-0950	15	FLAT WASHER IOGA 1.005" DIA X 25/64"
13	82-01-0965	2	BRACE
14	82-01-0955	1	BRACE
15	84-57-1325	1	CHUTE GUIDE GROUP

84-57-1325

#	PART #	Qty	TITLE
16	46-42-0107	1	CHUTE GUIDE (UNDER)
17	NC17-46-0030	3	CHUTE GUIDE (UNDER)
18	46-42-0106	1	CHUTE GUIDE (UNDER)
19	NC17-46-0029	3	CHUTE GUIDE (TOP)
20	46-42-0101	1	CHUTE GUIDE (TOP)
21	46-42-0102	1	CHUTE GUIDE (TOP)

#	PART #	QTY	TITLE
1	NC14-45-0150	1	HYDRAULIC MOTOR 315
2	48-50-1025	1	HYDRAULIC ENGINE SPROCKET
3	NC02-32-0012	4	LOCK WASHER ZINC 3/8"
4	NC01-33-0113	4	HEX.BOLT GR8 ZINC 3/8-16 X 3/4"
5	NC02-22-0009	1	WASHER
6	NC02-32-0010	1	LOCK WASHER ZINC 1/4"
7	NC01-33-0005	1	HEX. BOLT GR8 ZINC 1/4-20 X 7/8"
8	NC13-45-0073	2	STRAIGHT 7/8-14 MALE SAE10 O-RING X 3/8 FEM. TOUR. NPT
9	NC13-45-0369	2	QUICK COUPLER 1/2-14 NPTF
10	80-45-0000	2	HEX. REDUCER 1/4 NPT X 1/2 NPT
11	NC17-02-0328	2	HYDRAULIC HOSE (63" LG)
12	80-13-0100	2	HYDRAULIC RESTRICTOR
13	NC13-45-0378	2	HYDRAULIC RESTRICTOR BUSHING
14	NC17-46-0031	1	HYDRAULIC MOTOR BUSHING
15	NC02-44-0103	2	SET SCREW 5/16-18 X 3/8"

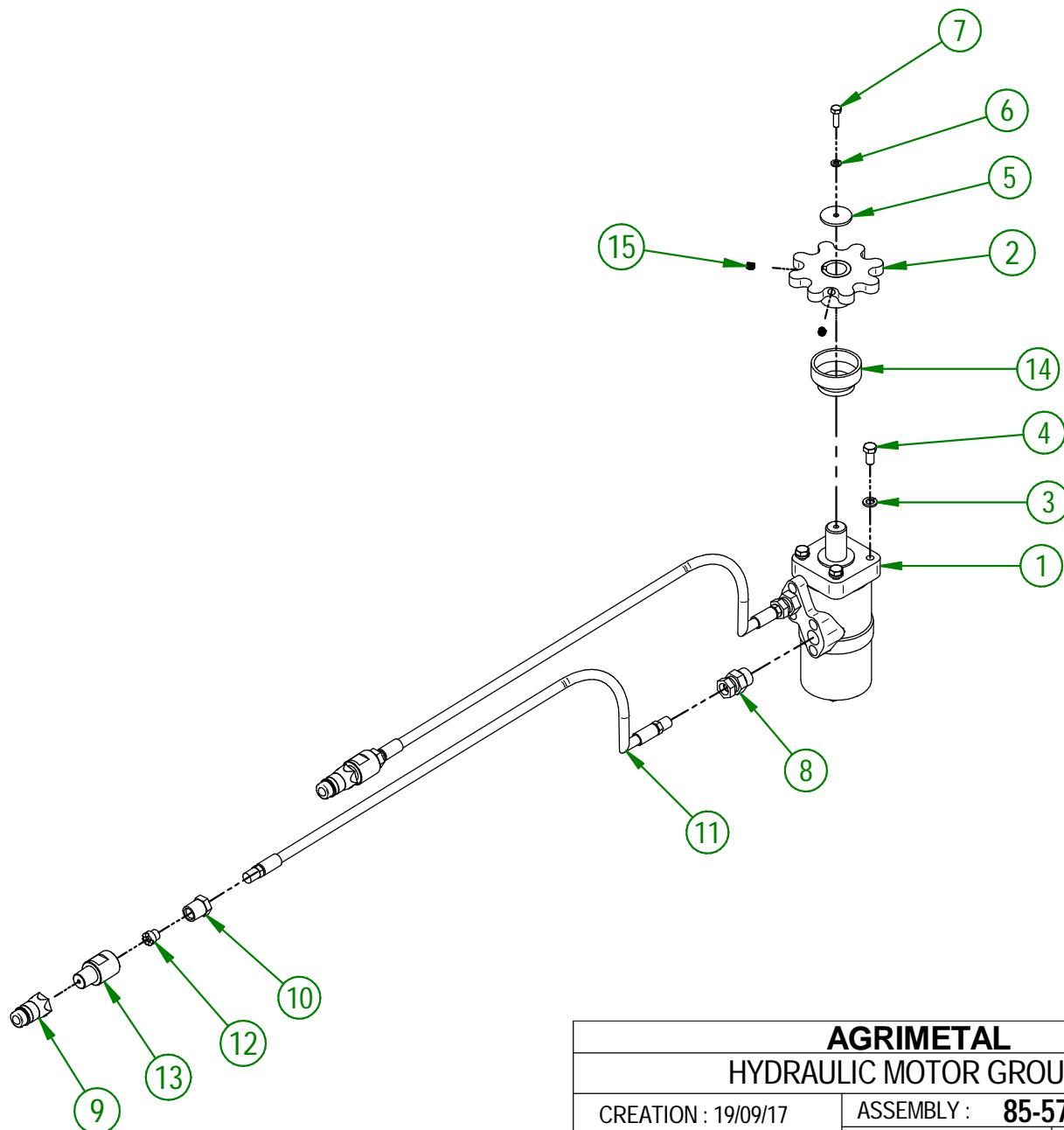

AGRIMETAL	
HYDRAULIC MOTOR GROUP	
CREATION : 19/09/17	ASSEMBLY : 85-57-0060
REVISION : 11/12/25	AUTHOR : J.KABWE

85-57-0151

#	PART #	Qty	TITLE
1	85-57-0187	1	MANUAL CHUTE
2	86-57-0131	1	MANUAL SYSTEM CHUTE GROUP

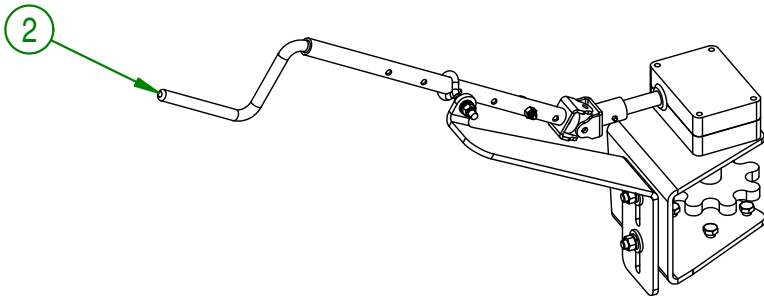
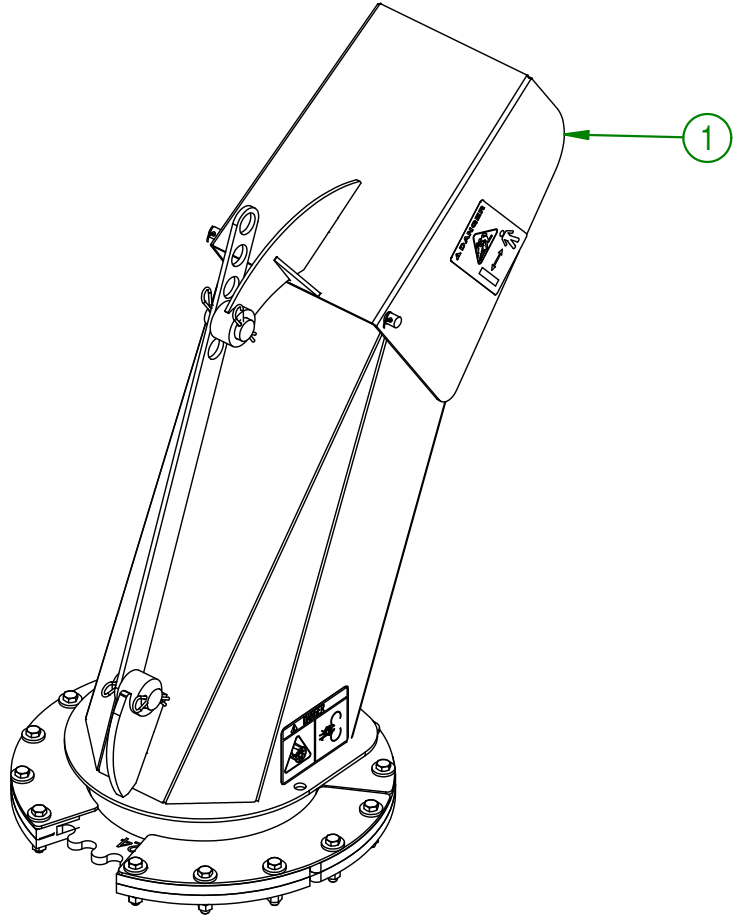

AGRIMETAL	
MANUAL CHUTE GROUP	
CREATION : 25/04/19	ASSEMBLY : 85-57-0151
REVISION : 27/06/19	AUTHOR : F.HÉLIE Page 22 de 26

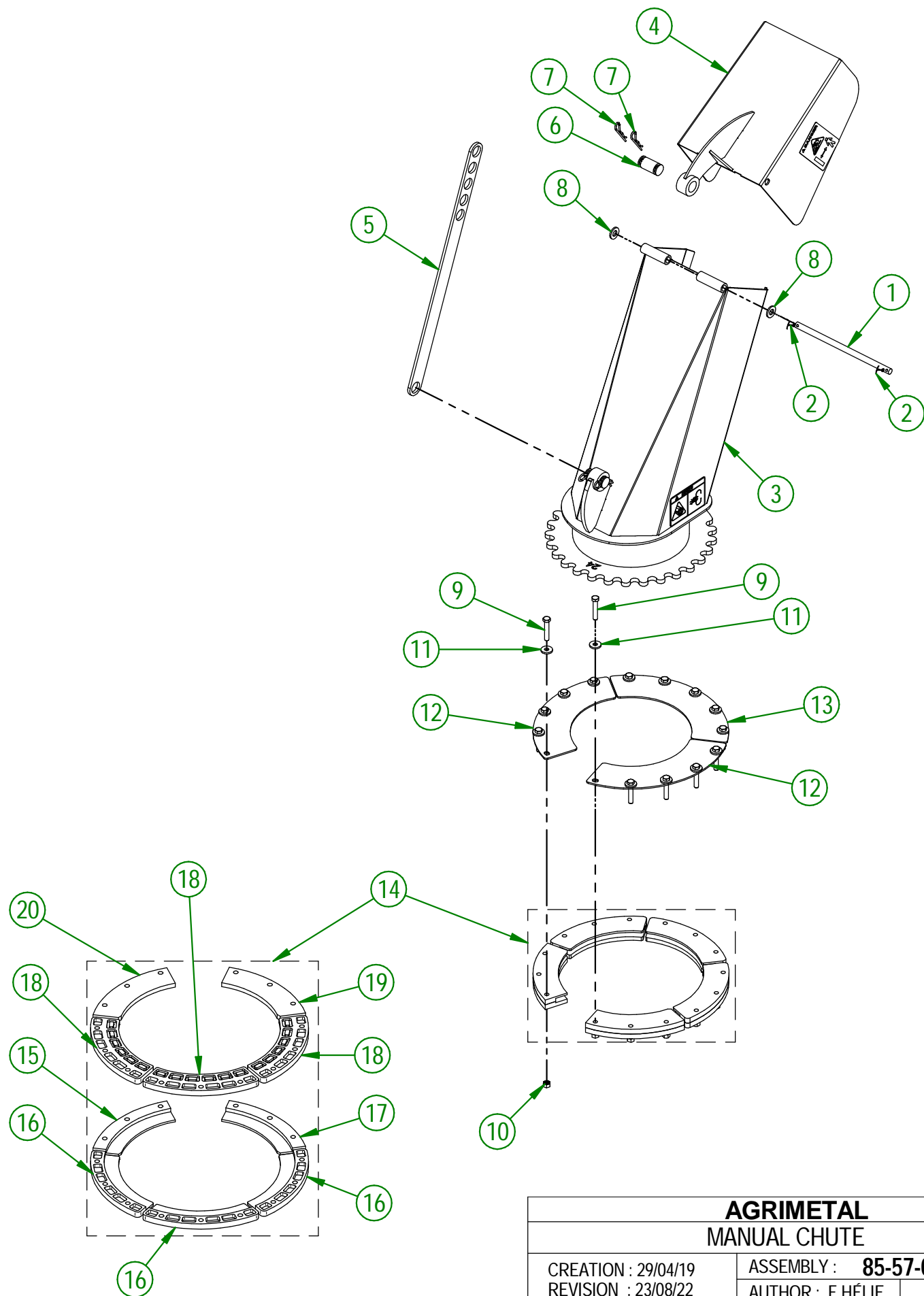

AGRIMETAL	
MANUAL CHUTE	
CREATION : 29/04/19	ASSEMBLY : 85-57-0187
REVISION : 23/08/22	AUTHOR : F.HÉLIE

85-57-0187

#	PART #	Qty	TITLE
1	85-13-0015	1	PIVOT
2	NC01-69-0139	2	COTTER PIN ZINC 1/8" X 3/4"
3	85-57-0110	1	CHUTE GROUP DOWN SECTION
4	85-57-0115	1	CHUTE GROUP UP SECTION
5	85-04-0450	1	CHUTE DEFLECTOR ADJUSTABLE PLATE
6	85-13-0480	2	PIVOT CHUTE DEFLECTOR PLATE
7	NC01-63-0015	4	COTTER PIN Z 1/8" X 2 5/8"
8	NC02-25-0011	2	WASHER SAE ZINC 17/32 ID
9	NC01-17-0118	15	HEX. BOLT GR2 ZINC 3/8-16 X 2"
10	NC01-93-0011	15	LOCK NUT 3/8-16
11	21-01-0950	15	FLAT WASHER IOGA 1.005" DIA X 25/64"
12	82-01-0965	2	BRACE
13	82-01-0955	1	BRACE
14	84-57-1325	1	CHUTE GUIDE GROUP

84-57-1325

#	PART #	Qty	TITLE
15	46-42-0107	1	CHUTE GUIDE (UNDER)
16	NC17-46-0030	3	CHUTE GUIDE (UNDER)
17	46-42-0106	1	CHUTE GUIDE (UNDER)
18	NC17-46-0029	3	CHUTE GUIDE (TOP)
19	46-42-0101	1	CHUTE GUIDE (TOP)
20	46-42-0102	1	CHUTE GUIDE (TOP)

AGRIMETAL
MANUAL CHUTE

CREATION : 29/04/19
 REVISION : 23/08/22

ASSEMBLY : **85-57-0187**
 AUTHOR : F.HÉLIE

#	PART #	Qty	TITLE
1	NC01-17-0114	4	HEX. BOLT GR2 ZINC 3/8-16 X 1"
2	NC02-32-0012	6	LOCK WASHER ZINC 3/8"
3	NC02-07-0018	6	HEX. NUT ZINC 3/8-16
4	86-01-0280	1	SPROCKET GUARD
5	85-03-0000	2	CHUTE SHIM
6	85-03-0001	1	CHUTE SHIM
7	86-50-0130	1	MANUAL CHUTE SPROCKET
8	85-21-0016	1	BALL JOINT
9	86-13-0075	1	CRANK ROD
10	NC01-97-0004	1	NYLON-INSERT LOCKNUT ZINC 1/4-28
11	NC01-37-0007	1	HEX.BOLT GR8 NF ZINC 1/4-28 X 1 1/4
12	NC01-52-0109	1	EYE BOLT 5/16-18X Ø 3/4" INT. X 3 1/4"LG
13	NC01-04-0110	2	CARR. BOLT GR2 ZINC 3/8-16 X 1 1/4"
14	NCI4-10-0166	1	GEARBOX
15	86-50-0056	1	ADJUSTABLE TUBE (MANUAL CHUTE)
16	85-50-0096	1	BALL JOINT ARM
17	NC01-69-0423	2	SPRING PIN 3/16" X 1 1/4"
18	NC01-96-0010	2	NYLON NUT HEX. ZINC 5/16-18
19	NC02-22-0008	3	WASHER ZINC 5/16"
20	NC02-32-0011	1	LOCK WASHER ZINC 5/16"
21	21-01-0950	2	FLAT WASHER IOGA 1.005" DIA X 25/64"
22	NC01-00-0381	4	AIRCRAFT BOLT 1/4-28 X 3/16" X .656 L.T.Z. (AN4-5A)
23	86-50-0140	1	GEARBOX BRACKET
24	86-50-0145	1	CRANK HOLDER

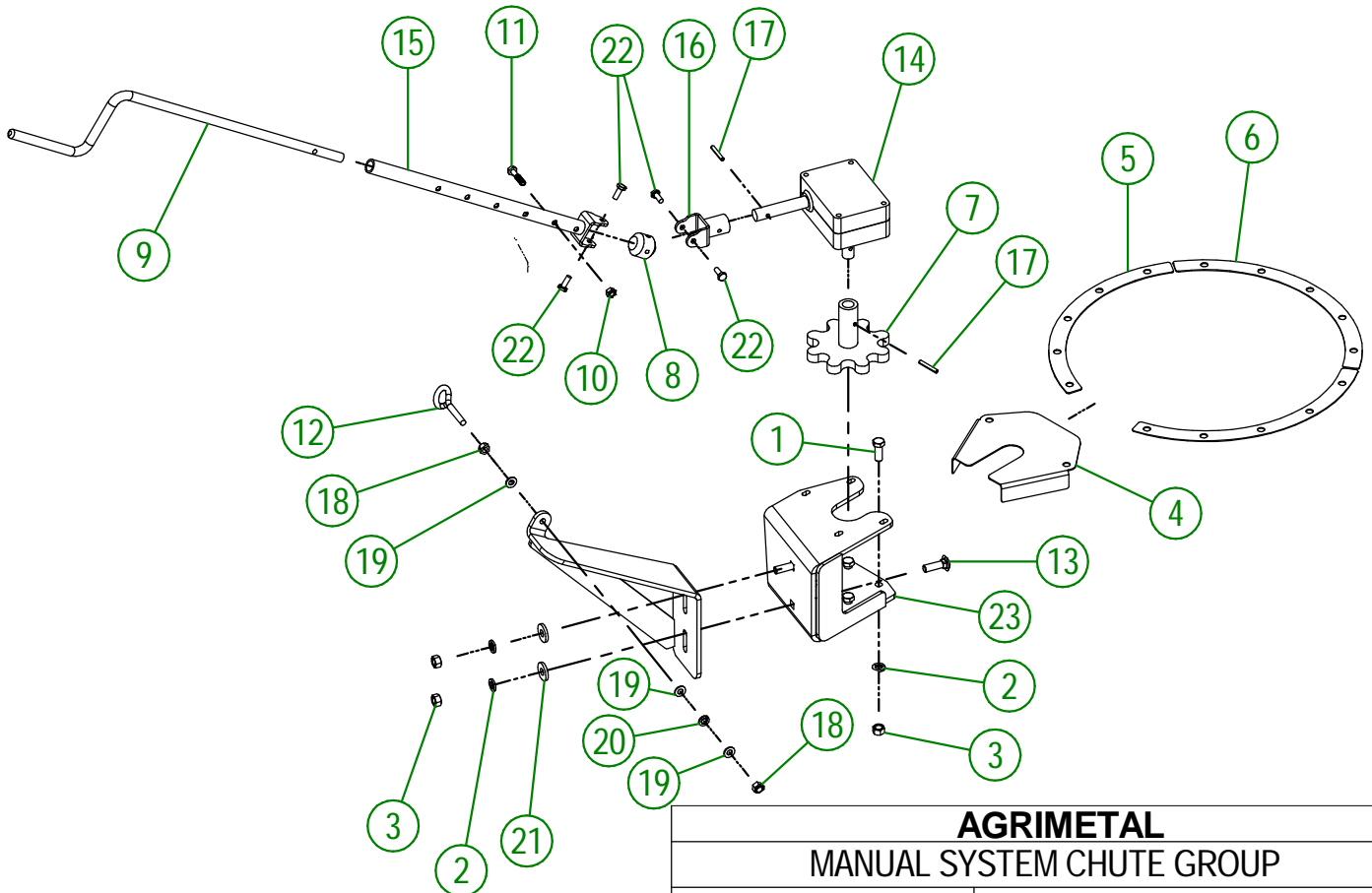

AGRIMETAL	
MANUAL SYSTEM CHUTE GROUP	
CREATION : 23/04/19	ASSEMBLY : 86-57-0131
REVISION : 23/08/22	AUTHOR : F.HÉLIE

#	PART #	QTY	TITLE
1	NCI3-33-0304	1	STICKER YUKON
2	NCI3-33-0024	4	STICKER GREASE HERE
3	NCI3-33-0183	1	STICKER CAUTION OPERATION MANUAL
4	NCI3-33-0280	1	STICKER SHEAR BOLT
5	NCI3-33-0189	1	STICKER DANGER (PERSON AND CHAIN DRIVE)
6	NCI3-33-0274	1	STICKER DANGER
7	NCI3-33-0035	2	STICKER AGRIMETAL
8	NCI3-33-0312	1	STICKER 2476
9	NCI3-33-0317	1	STICKER GREASE DRIVE LINE TELESCOPIC SHAFT
10	NCI3-33-0005	1	STICKER MAXIMUM 540 RPM
11	NCI3-33-0187	1	STICKER DANGER (PTO AND PERSON)
12	NCI3-33-0249	2	STICKER DANGER
13	NCI3-33-0192	2	STICKER (PROJECTION RISK)
14	NCI3-33-0283	1	STICKER DANGER (PERSON AND CHAIN DRIVE)

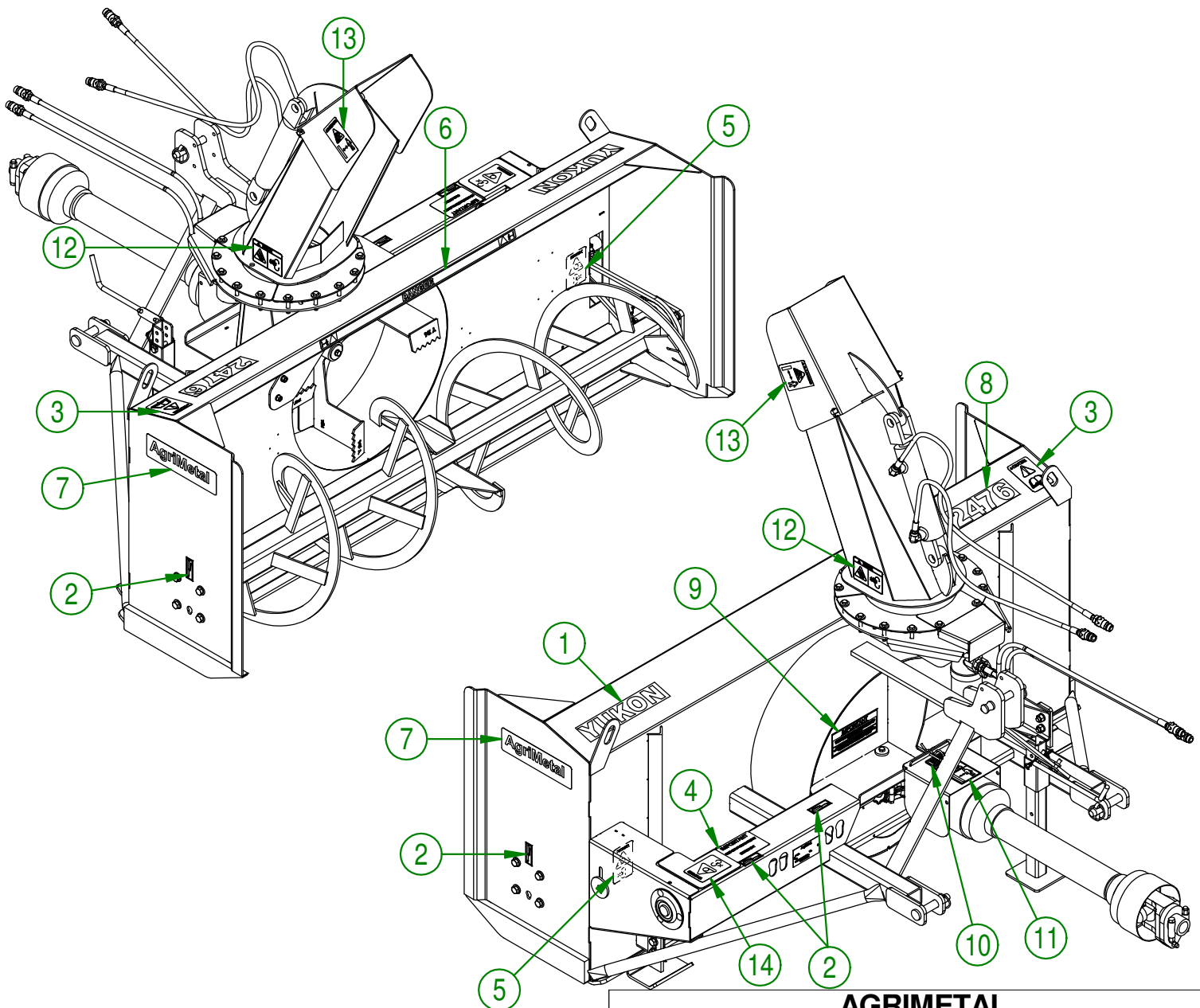

AGRIMETAL
YUKON 2476

CREATION : 31/10/17
REVISION : 07/03/19

ASSEMBLY : **85-99-0000**

AUTHOR : J.KABWE Page 26 de 26