

AgriMetal

PARTS LIST

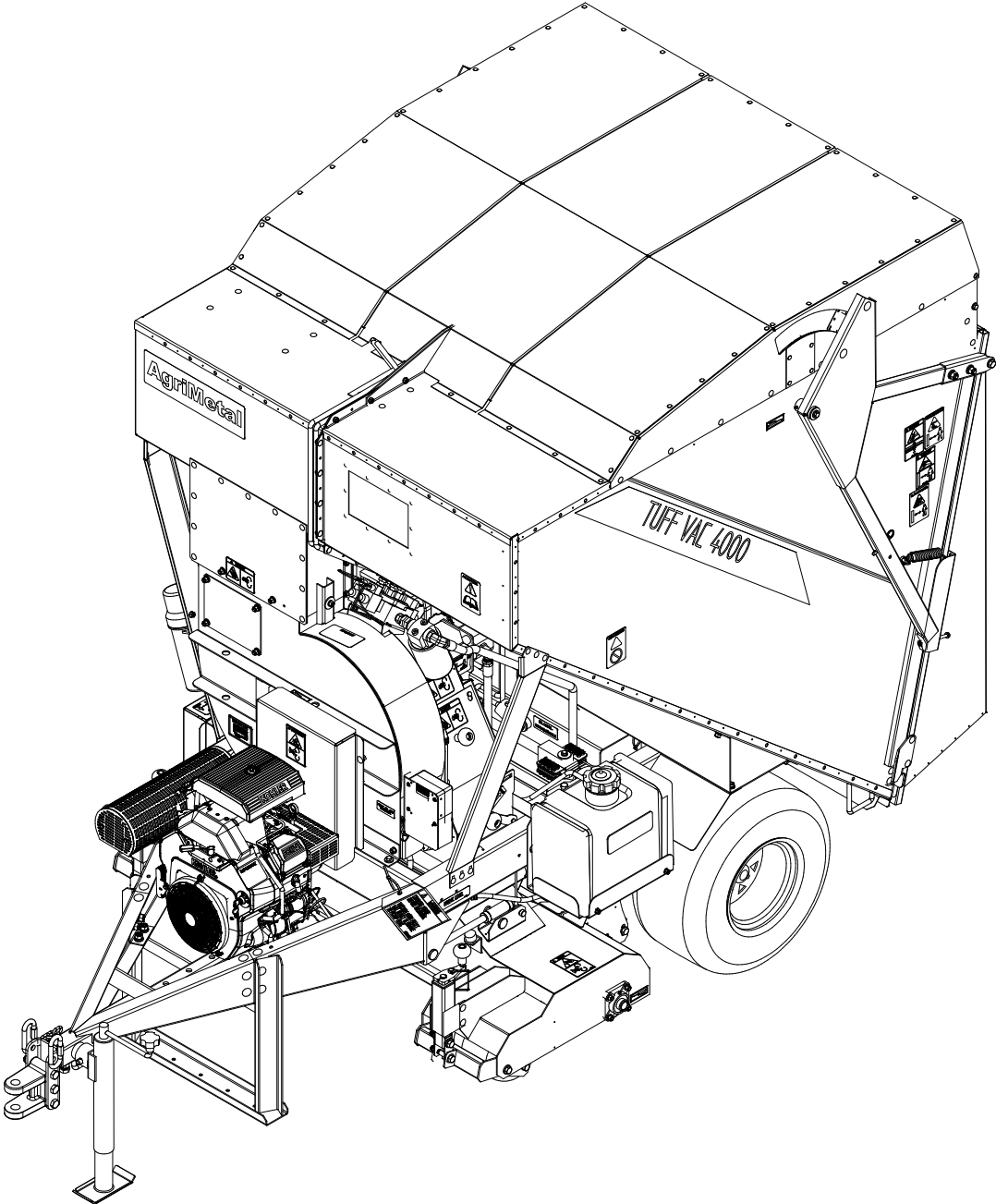

TUFF VAC 4000 GAZ

#	PART #	QTY	TITLE
1	22-55-0025	1	SCREEN 1/4" ASS'Y
2	22-55-0030	1	SCREEN 1/2"
3	22-50-0157	1	SHIPPING LEG
4	22-55-0320	1	JACK
5	22-55-0265	2	WASHABLE HARD SURFACE FILTER KIT (OPTION)
6	22-55-0053	1	NYLON BRISTLE ROTARY BRUSH HEAD ASS'Y
7	22-55-0051	1	DETHATCHING HEAD WITH KNIVES SYSTEM ASS'Y
8	22-55-0046	1	PICK UP HEAD WITH ROTATIVE BRUSH (RUBBER FINGER)
9	22-57-0195	2	PICK UP HEAD ARM
10	22-57-0606	1	REMOTE CONTROL GROUP
11	NCI3-50-0123	1	WARNING TYVEK STICKER
12	25-55-0710	1	SERIAL NUMBER PLATE
13	NCI7-11-0006	1	EXPANDING BOOT

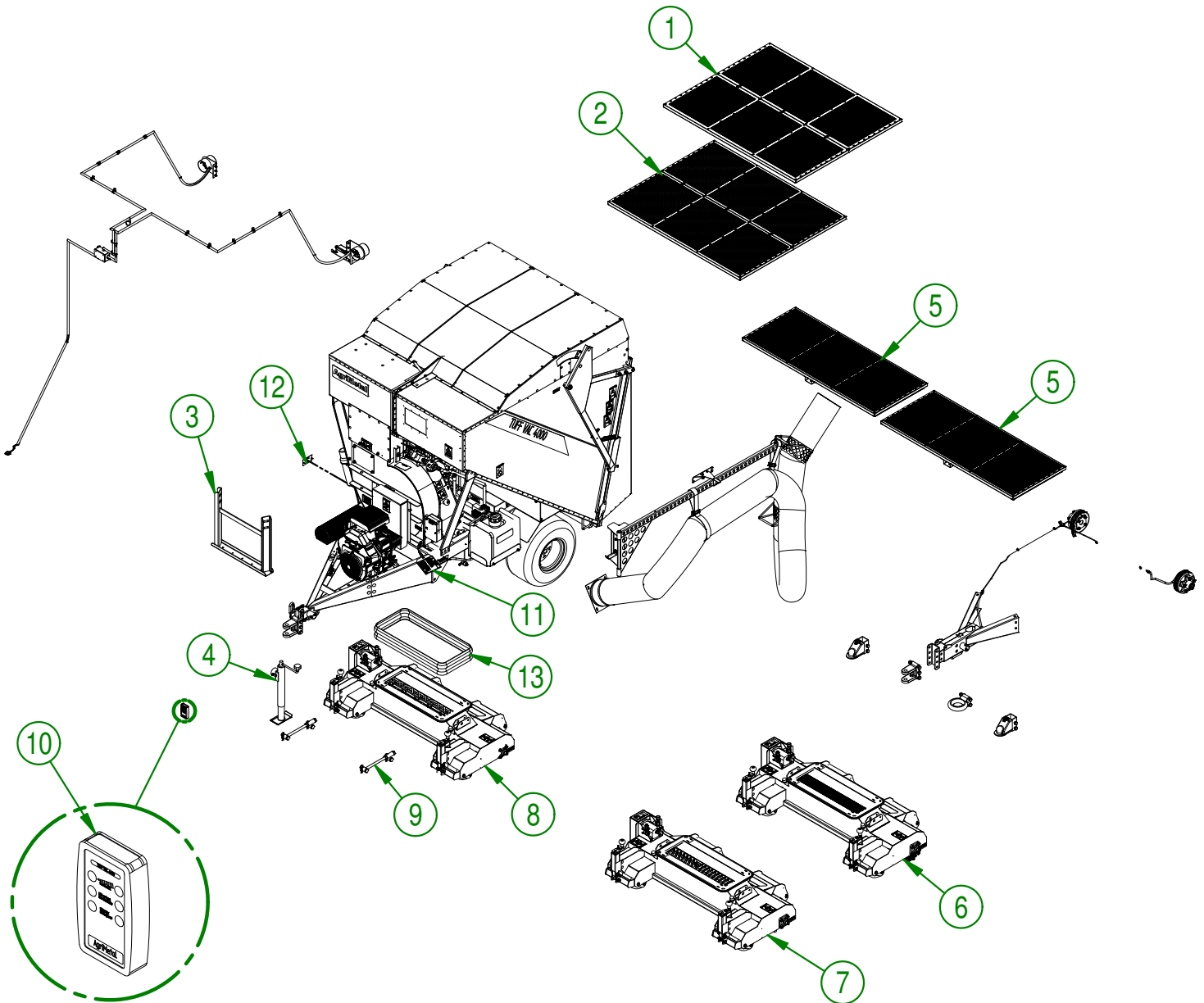

#	PART #	Qty	TITLE
1	22-55-0630	1	RED BATTERY CABLE WITH TERMINAL (105" LG.)
2	22-55-0635	1	BLACK BATTERY CABLE WITH TERMINAL 115" LG.
3	NCI3-25-0019	14	BLACK TIE RAP

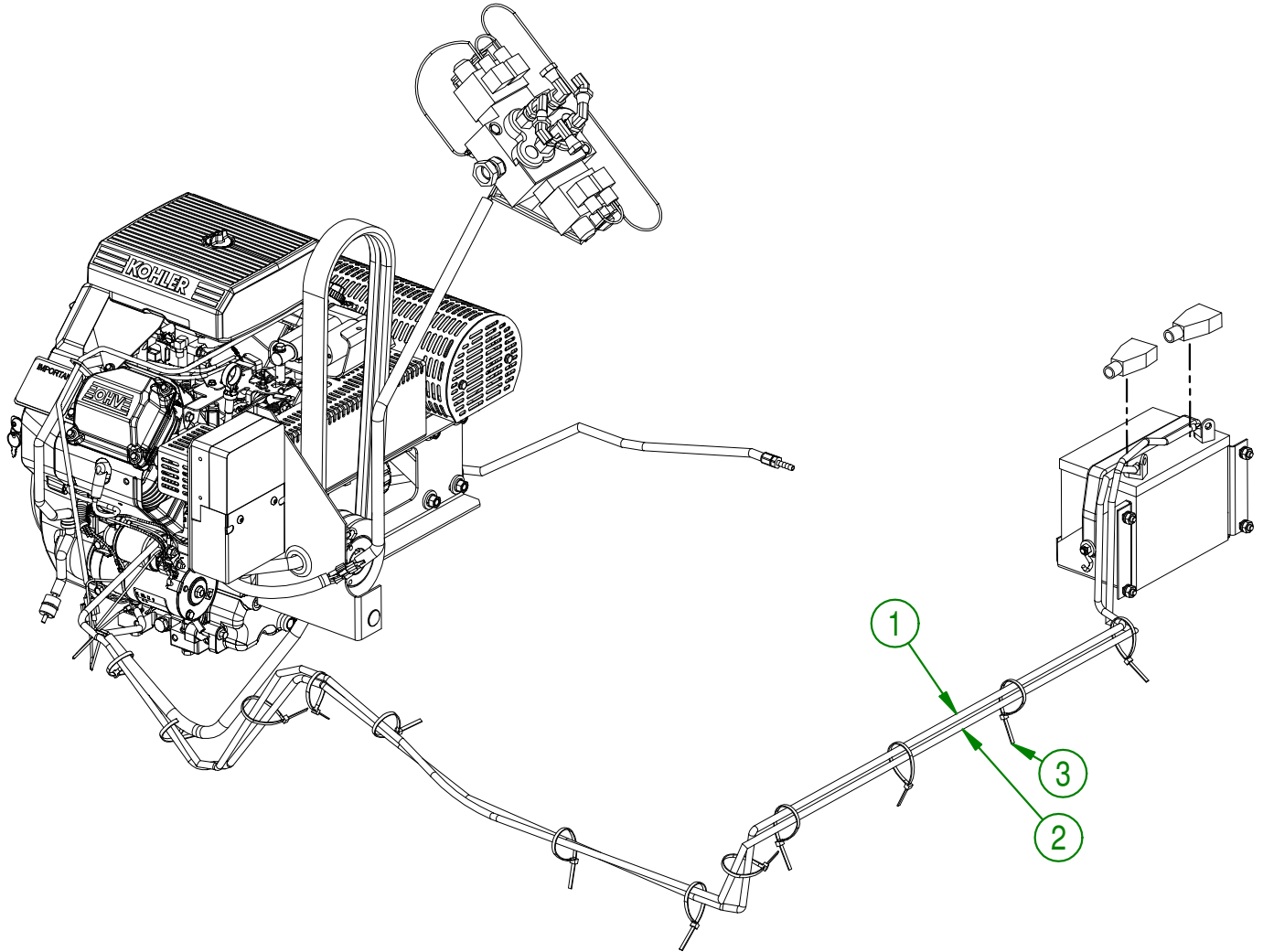

AGRIMETAL
ELECTRICAL DIAGRAM

CREATION : 28/05/18
REVISION : 28/05/18

ASSEMBLY : **22-99-0537**

AUTHOR : F.HÉLIE

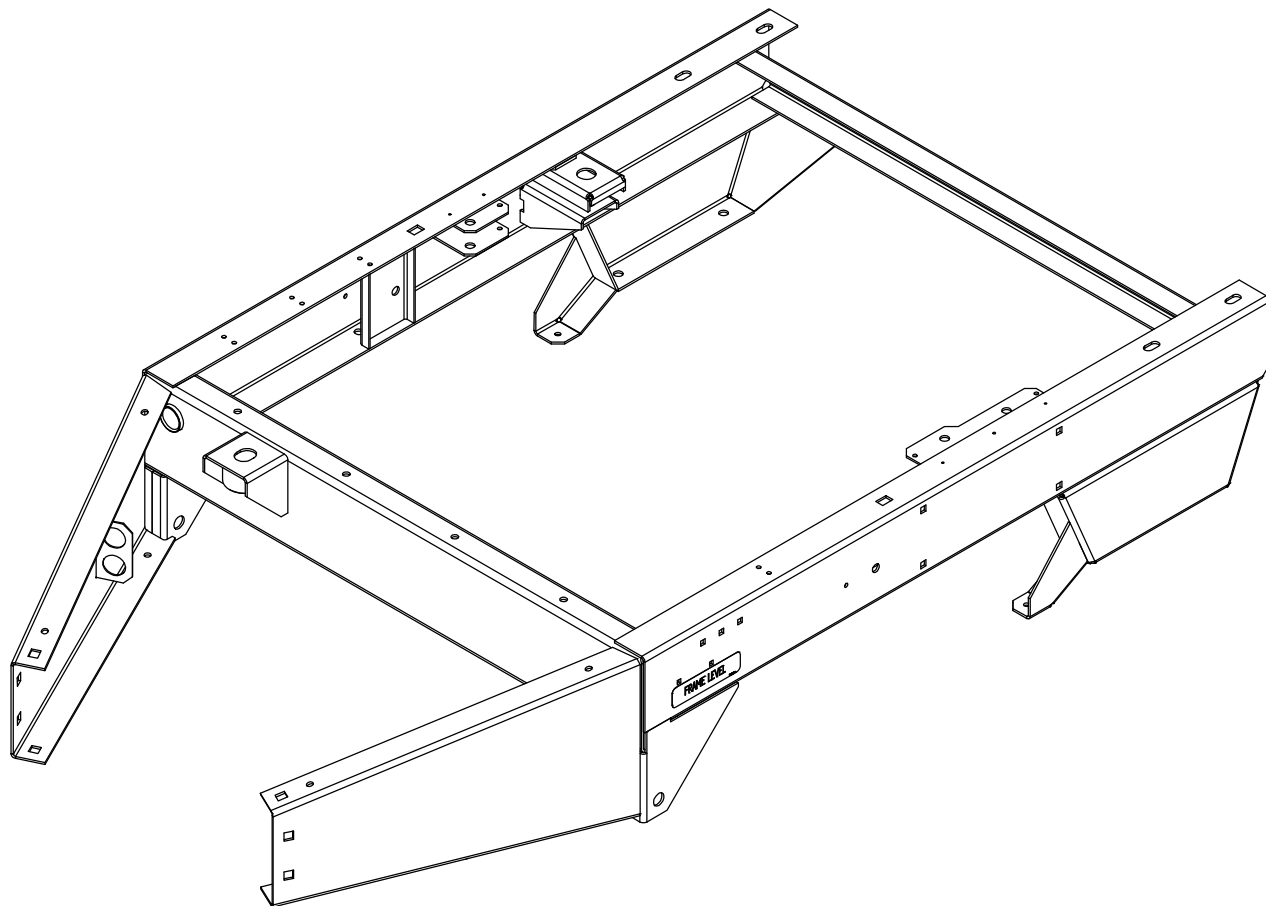

AGRIMETAL

ASSEMBLY FRAME " STICKER INCLUDED" (PTO & GAZ)

CREATION : 14/11/17
REVISION : 15/06/18

ASSEMBLY : **22-57-0580**

AUTHOR : F.HÉLIE

Page 4 de 70

#	PART #	Qty	TITLE
1	NC01-17-0402	1	HEX. BOLT GR2 ZINC 5/8-11 X 3 1/2"
2	NC02-22-0013	1	WASHER ZINC 5/8 ID X 1 1/2 OD
3	NC01-96-0016	1	NYLON INSERT NUT 5/8-11
4	22-50-0083	1	EXTENSION HITCH
5	22-01-0956	1	LEFT HITCH JOINT BRACKET
6	22-01-0961	1	RIGHT HITCH JOINT BRACKET
7	NC01-04-0233	16	CARR. BOLT GR2 ZINC 1/2-13 X 1"
8	01-01-0925	16	WASHER
9	NC02-32-0014	16	LOCK WASHER ZINC 1/2"
10	NC02-07-0020	16	HEX. NUT ZINC 1/2-13
11	22-50-0075	1	TELESCOPING HITCH
12	NC01-33-0406	3	HEX. BOLT GR8 ZINC 5/8-11 X 4 1/2" LG
13	NC02-32-0016	3	LOCK WASHER ZINC 5/8"
14	NC02-07-0022	4	HEX. NUT ZINC 5/8-11
15	NC01-17-0394	1	HEX. BOLT GR2 ZINC 5/8-11 X 1 1/2"
16	16-41-0040	1	CHAIN 58"
17	NC01-75-0007	2	CONNECTING LINK APROVED 1/2 3300/LBS WLL
18	NC13-80-0241	1	ADJUSTABLE 1" CLEVIS (3 HOLES)

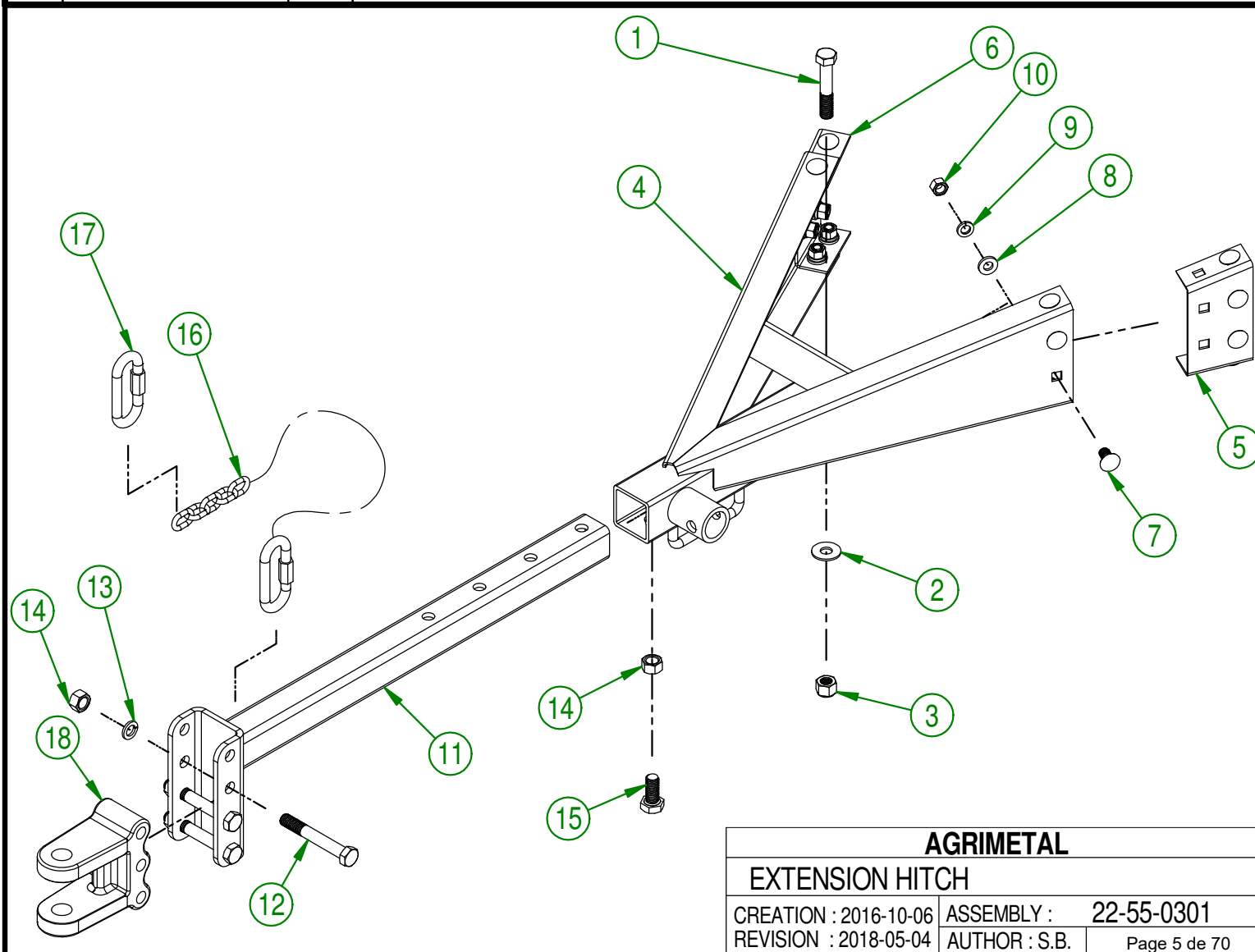

AGRIMETAL			
EXTENSION HITCH			
CREATION : 2016-10-06	ASSEMBLY :	22-55-0301	
REVISION : 2018-05-04	AUTHOR : S.B.	Page 5 de 70	

22-57-0691

#	PART #	Qty	TITLE
1	NC01-17-0467	2	HEX. BOLT GR2 ZINC 3/4-10 X 2"
2	22-04-6805	4	FLAT WASHER BEARING BASE
3	22-09-1200	2	BUSHING
4	NC02-32-0017	2	LOCK WASHER ZINC 3/4"
5	NC02-07-0023	2	HEX. NUT ZINC 3/4-10
6	22-55-0066	1	BELT TENSION KIT ASSY
7	22-50-1012	1	MOTOR BASE (KOHLER GAZ)

22-55-0066

#	PART #	Qty	TITLE
8	22-55-0067	1	BELT TENSION
9	22-04-6805	1	FLAT WASHER BEARING BASE
10	NC13-86-0083	1	BLUE SPRING 1/2" ID X 1" OD X 8"
11	22-42-0125	1	TENSIONER GUIDE

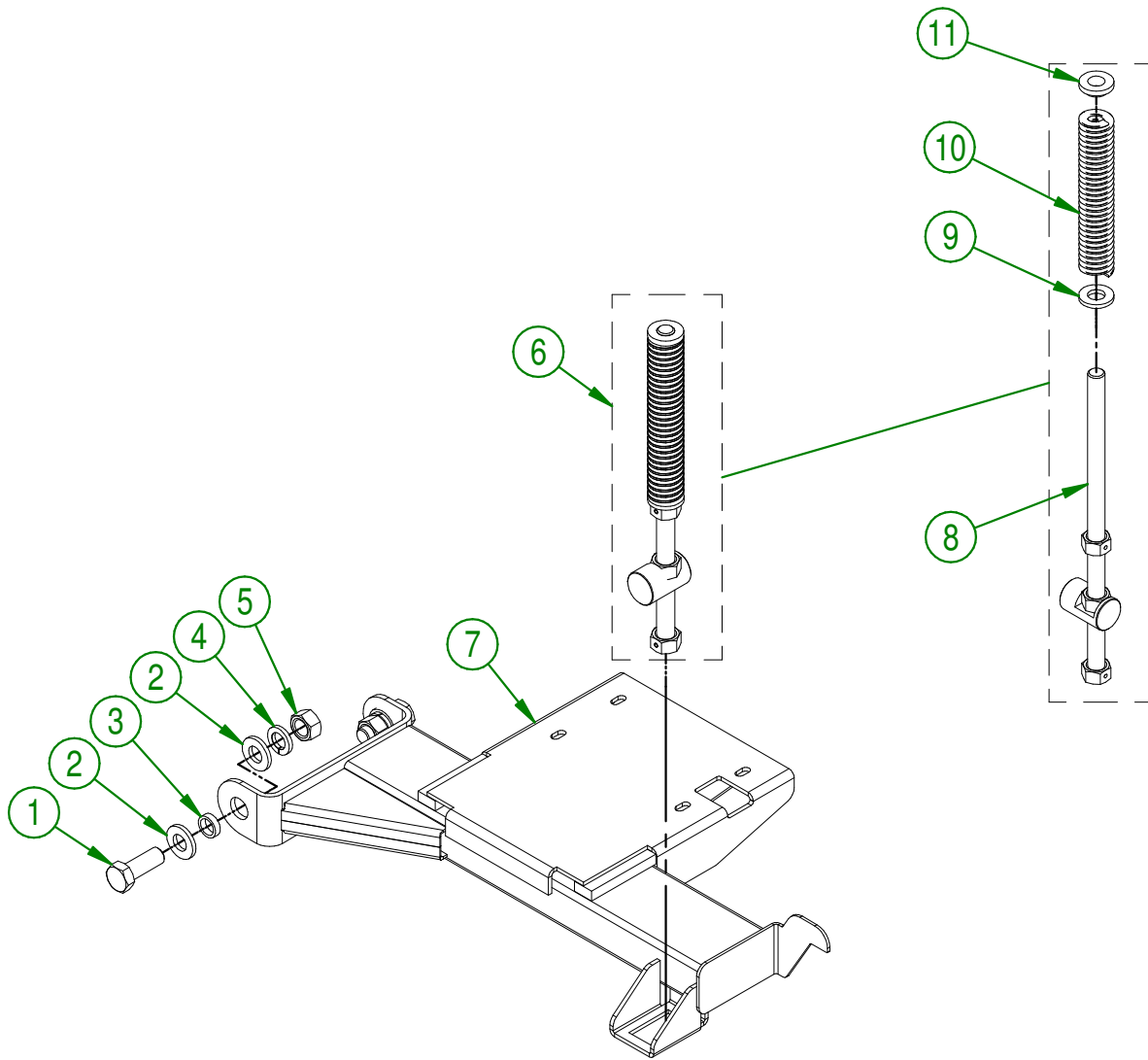

USE THESE PIECES ONLY IF YOUR SERIAL NUMBER IS AFFECTED:

#39551 AND UNDER

AGRIMETAL	
ASSEMBLY ENGINE BASE	
CREATION : 28/05/18	ASSEMBLY : 22-57-0691
REVISION : 14/01/21	AUTHOR : F.HÉLIE

22-57-0692

#	PART #	Qty	TITLE
1	NC01-17-0467	2	HEX. BOLT GR2 ZINC 3/4-10 X 2"
2	22-04-6805	4	FLAT WASHER BEARING BASE
3	22-09-1200	2	BUSHING
4	22-55-0066	1	BELT TENSION KIT ASS'Y
5	22-50-1011	1	MOTOR BASE (KOHLEK GAZ)
6*	NC01-93-0017	2	HEX. LOCKNUT STEEL NF Z 3/4-10

22-55-0066

#	PART #	Qty	TITLE
8	22-55-0067	1	BELT TENSION
9	22-04-6805	1	FLAT WASHER BEARING BASE
10	NC13-86-0083	1	BLUE SPRING 1/2" ID X 1" OD X 8"
11	22-42-0125	1	TENSIONER GUIDE

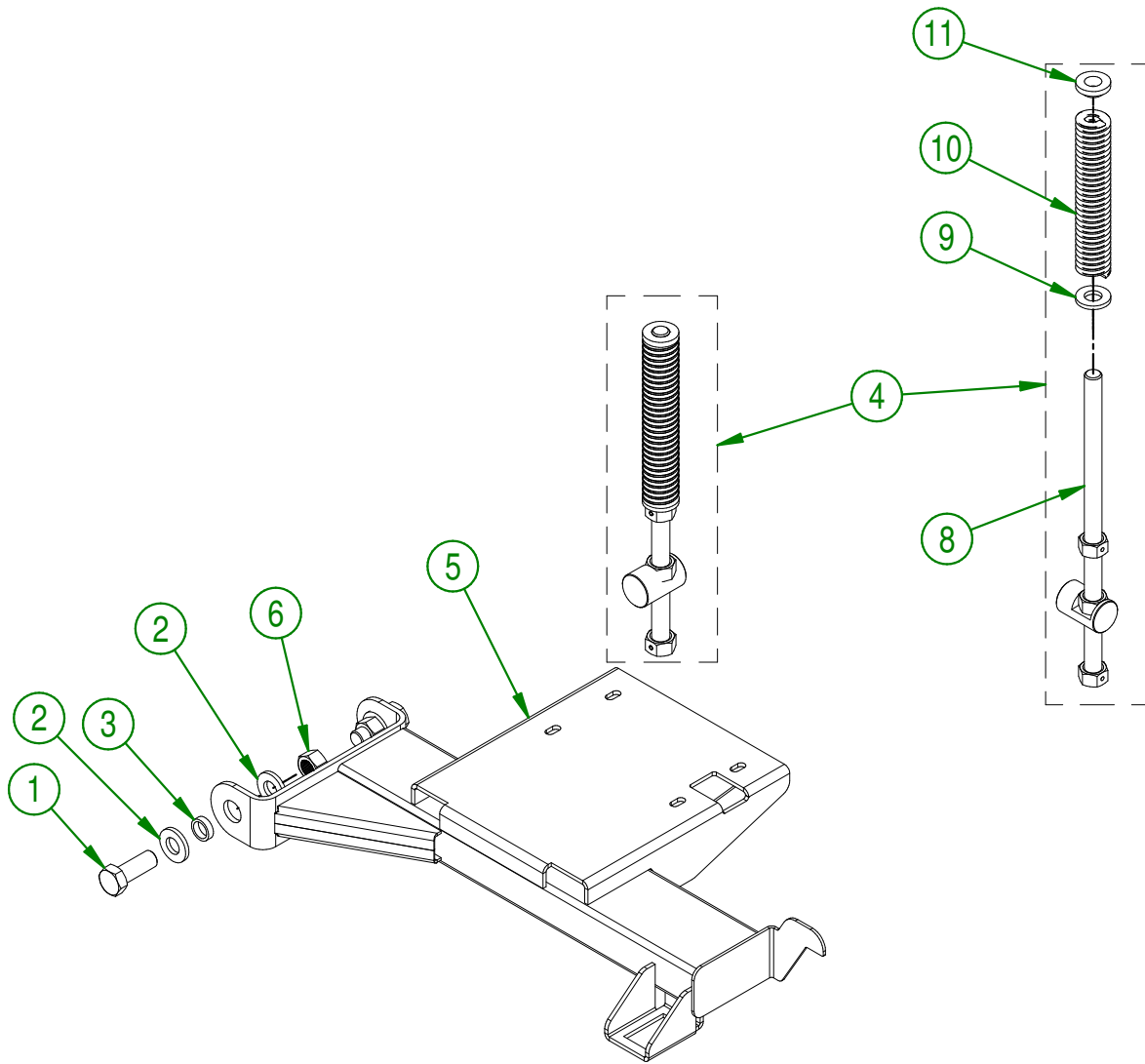

USE THESE PIECES ONLY IF YOUR SERIAL NUMBER IS AFFECTED:

#39552 AND ABOVE

AGRIMETAL	
ASSEMBLY ENGINE BASE	
CREATION : 15/01/21	ASSEMBLY : 22-57-0692
REVISION : 25/05/21	AUTHOR : F.HÉLIE

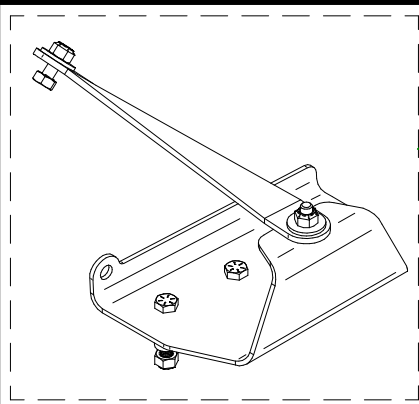

OLD VERSION

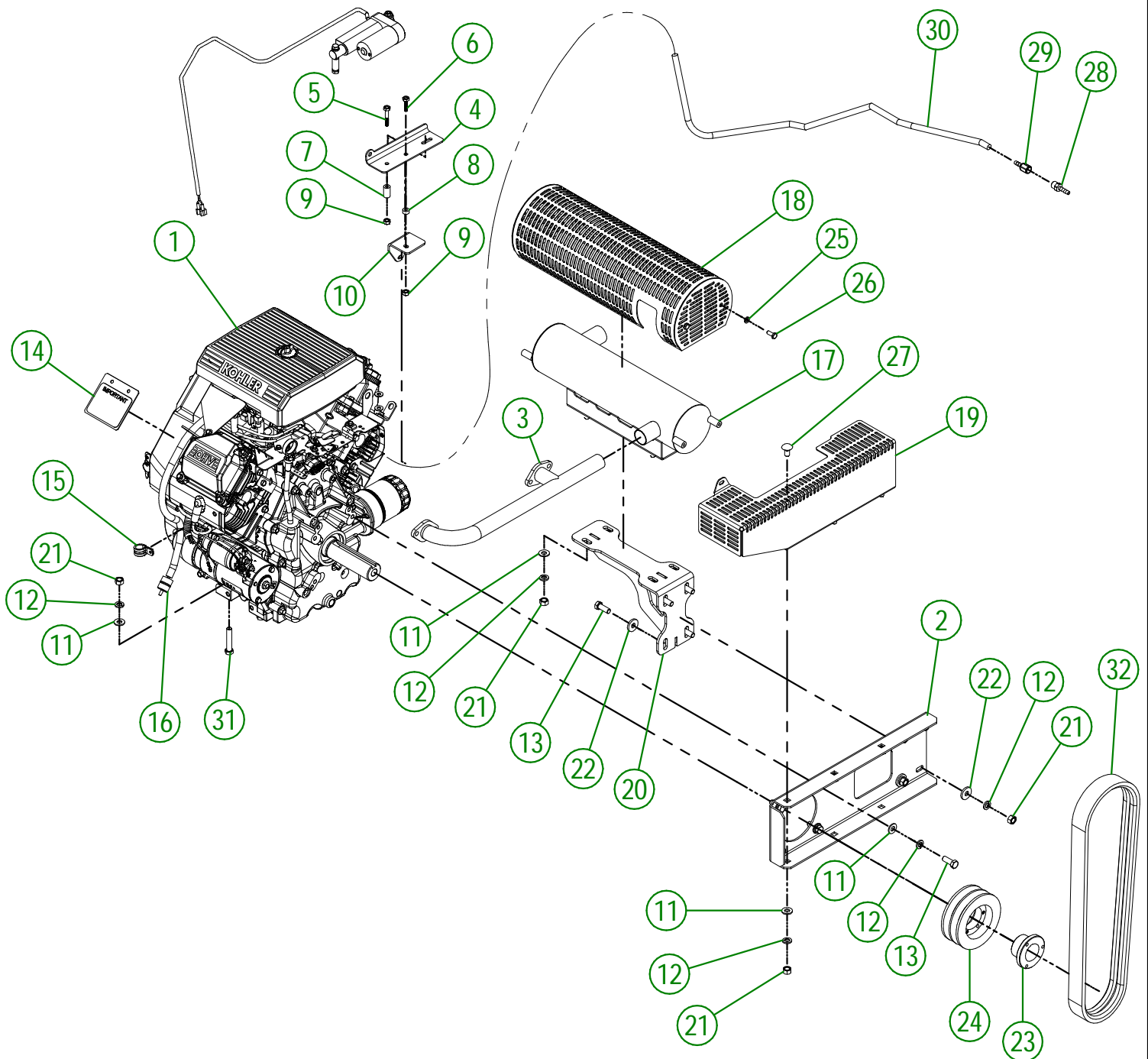

USE THESE PIECES ONLY IF YOUR SERIAL NUMBER IS AFFECTED:

#39551 AND BELOW

AGRIMETAL	
REGROUP. MOTEUR KOHLER COMPL.	
CREATION : 2017-11-23	ASSEMBLY : 22-57-0502
REVISION : 2025-06-03	AUTHOR : dessin3

22-57-0502

#	PART #	QTY	TITLE
1	NC14-40-0049	1	27 HP KOHLER MOTOR
2	33-01-0900	1	MOFFLER SUPPORT
3	33-35-5000	1	EXHAUST MANIFOLD
4	33-01-0040	1	ACTUATOR SUPPORT
5	NC01-37-0008	1	HEX. BOLT GR8 1/4-28 X 1 1/2"
6	NC01-37-0006	1	HEX BOLT GR8 NF ZINC 1/4-28 X 1
7	33-21-0070	1	ACTUATOR SUPPORT BUSHING
8	33-21-0075	1	ACTUATOR SUPPORT BUSHING
9	NC01-97-0004	2	NYLON-INSERT LOCKNUT ZINC 1/4-28
10	33-01-0425	1	ACTUATOR SUPPORT
11	01-01-2485	15	FLAT WASHER 14 GA X 13/16"OD X 25/64" ID
12	NC02-32-0012	19	LOCK WASHER ZINC 3/8"
13	NC01-17-0114	8	HEX. BOLT GR2 ZINC 3/8-16 X 1"
14	33-55-0090	1	ENGINE PLATE ASSY.
15	NC13-25-0110	1	SNUG-FIT DAMPING LOOP CLAMP
16	33-46-0527	1	1/4" GAS HOSE
17	33-50-1050	1	27 HP KOHLER MUFFLER
18	33-50-1055	1	MUFFLER GUARD (27 HP KOHLER)
19	22-01-0000	1	EXHAUST GUARD
20	22-50-0300	1	MUFFLER SUPPORT (KOHLER 27 HP)
21	NC02-07-0018	15	HEX. NUT ZINC 3/8-16
22	21-01-0950	8	FLAT WASHER 10GA 1.005" DIA X 25/64"
23	NC14-62-0211	1	QD BUSHING SH 1 7/16"
24	NC14-62-0085	1	PULLEY QD 2V1/2-5/8 X 4.550D X SH 2B42
25	NC02-32-0010	4	LOCK WASHER ZINC 1/4"
26	NC01-29-0003	4	HEX. BOLT GR5 ZINC 1/4-28 X 5/8"
27	NC01-04-0107	3	CARR. BOLT GR2 ZINC 3/8-16 X 3/4"
28	NC13-65-0061	1	BARBILLON HOSE 1/4 OD X 1/4 NPT MALE
29	NC13-65-0062	1	BARBILLON HOSE 3/16 OD X 1/4 NPT FEMALE
30	22-46-0030	1	GAZ LINE VAPOR 3/16" DIA. X 32" LG.
31	NC01-17-0118	4	HEX. BOLT GR2 ZINC 3/8-16 X 2"
32	NC14-25-2558	1	HI-POWER V BELT 2RB-44

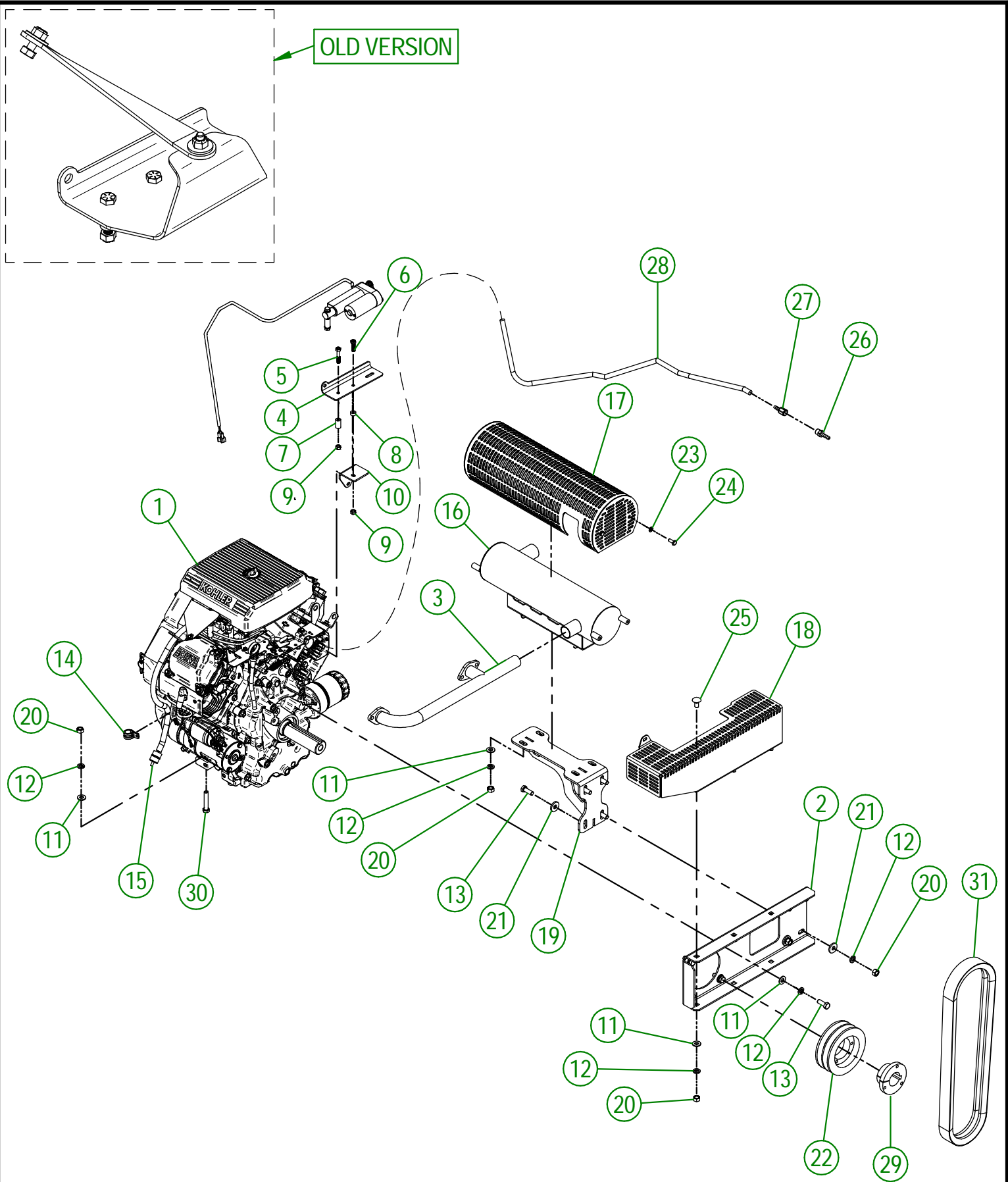

USE THESE PIECES ONLY IF YOUR SERIAL NUMBER IS AFFECTED:

#39552 AND ABOVE

AGRIMETAL	
ASSEMBLY KOHLER ENGINE	
CREATION : 14/01/21	ASSEMBLY : 22-57-0503
REVISION : 07/07/25	AUTHOR : J. Houle

22-57-0503

#	PART #	QTY	TITLE
1	NC14-40-0049	1	27 HP KOHLER MOTOR
2	33-01-0900	1	MOFFLER SUPPORT
3	33-35-5000	1	EXHAUST MANIFOLD
4	33-01-0040	1	ACTUATOR SUPPORT
5	NC01-37-0008	1	HEX. BOLT GR8 1/4-28 X 1 1/2"
6	NC01-37-0006	1	HEX BOLT GR8 NF ZINC 1/4-28 X 1
7	33-21-0070	1	ACTUATOR SUPPORT BUSHING
8	33-21-0075	1	ACTUATOR SUPPORT BUSHING
9	NC01-97-0004	2	NYLON-INSERT LOCKNUT ZINC 1/4-28
10	33-01-0425	1	ACTUATOR SUPPORT
11	01-01-2485	15	FLAT WASHER 14 GA X 13/16"OD X 25/64" ID
12	NC02-32-0012	19	LOCK WASHER ZINC 3/8"
13	NC01-17-0114	8	HEX. BOLT GR2 ZINC 3/8-16 X 1"
14	NC13-25-0110	1	SNUG-FIT DAMPING LOOP CLAMP
15	33-46-0527	1	1/4" GAS HOSE
16	33-50-1050	1	27 HP KOHLER MUFFLER
17	33-50-1055	1	MUFFLER GUARD (27 HP KOHLER)
18	22-01-0000	1	EXHAUST GUARD
19	22-50-0300	1	MUFFLER SUPPORT (KOHLER 27 HP)
20	NC02-07-0018	15	HEX. NUT ZINC 3/8-16
21	21-01-0950	8	FLAT WASHER 10GA 1.005" DIA X 25/64"
22	NC14-62-0229	1	PULLEY QD 2V1/2-5/8 X 4.950D X SDS 2B46
23	NC02-32-0010	4	LOCK WASHER ZINC 1/4"
24	NC01-29-0003	4	HEX. BOLT GR5 ZINC 1/4-28 X 5/8"
25	NC01-04-0107	3	CARR. BOLT GR2 ZINC 3/8-16 X 3/4"
26	NC13-65-0061	1	BARBILLON HOSE 1/4 OD X 1/4 NPT MALE
27	NC13-65-0062	1	BARBILLON HOSE 3/16 OD X 1/4 NPT FEMALE
28	22-46-0030	1	GAZ LINE VAPOR 3/16" DIA. X 32" LG.
29	NC14-62-0215	1	QD BUSHING SDS 1 7/16"
30	NC01-17-0118	4	HEX. BOLT GR2 ZINC 3/8-16 X 2"
31	NC14-25-2558	1	HI-POWER V BELT 2RB-44

#	PART #	Qty	TITLE
1	33-01-0040	1	ACTUATOR SUPPORT
2	NC01-37-0008	1	HEX. BOLT GR8 1/4-28 X 1 1/2"
3	NC01-37-0004	3	HEX. BOLT GR2 ZINC 1/4-28 X 3/4"
4	33-21-0070	1	ACTUATOR SUPPORT BUSHING
5	33-21-0075	1	ACTUATOR SUPPORT BUSHING
6	NC01-97-0004	4	NYLON-INSERT LOCKNUT ZINC 1/4-28
7	33-01-0045	1	ACTUATOR REINFORCING SUPPORT
8	36-01-2430	2	FLAT WASHER 14GA X 17/64" I.D. X 13/16" O.D.

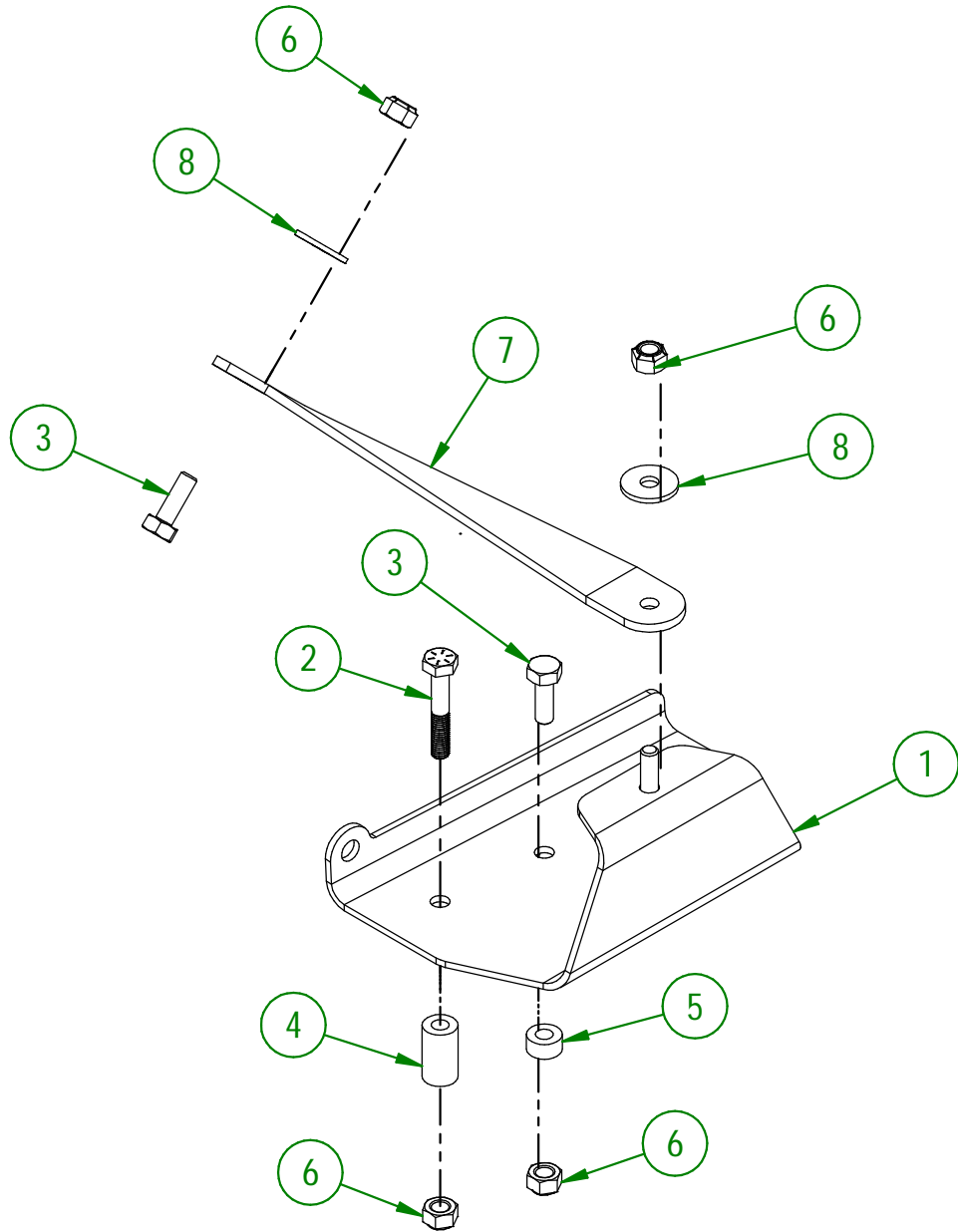

AGRIMETAL	
ACTUATOR SUPPORT GROUP.	
CREATION : 17/04/18	ASSEMBLY : 33-57-0104
REVISION : 29/06/23	AUTHOR : J.KABWE

#	PART #	Qty	TITLE
1	33-55-0100	1	ACTUATOR 12 VOLTS
2	33-57-0107	1	ACTION ROD
3	NC01-37-0011	1	HEX. BOLT GR8 1/4-28 X 2 1/4
4	33-42-0120	2	PIVOT BUSHING
5	NC02-14-1200	1	TWO WAY LOCK NUT 1/4-28
6	NC02-25-0007	4	WASHER ZINC 0.281 = 9/32
7	36-01-2430	2	FLAT WASHER 14GA X 17/64" I.D. X 13/16" O.D.
8	NC01-97-0004	1	NYLON-INSERT LOCKNUT ZINC 1/4-28

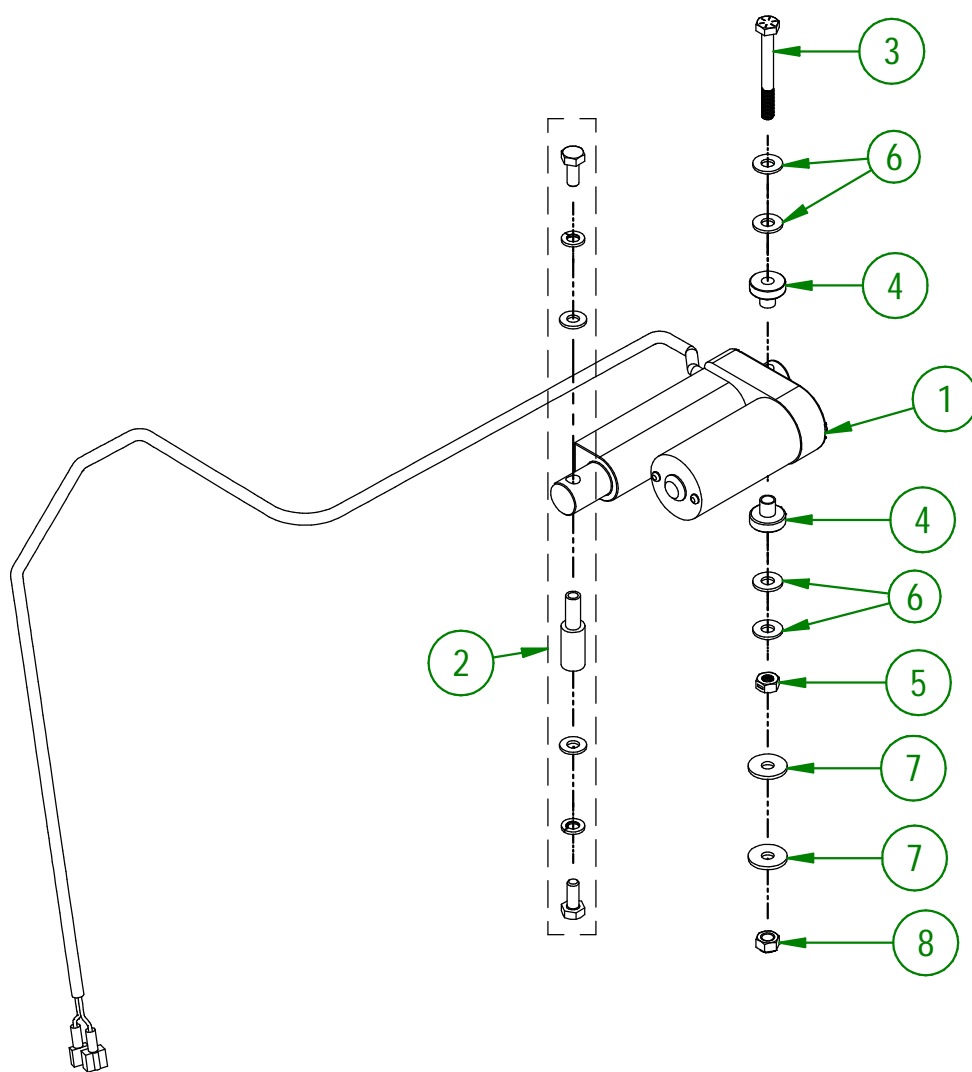

AGRIMETAL	
ASSEMBLY ACTUATOR 12 VOLTS	
CREATION : 17/04/18	ASSEMBLY : 33-55-0107
REVISION : 12/05/23	AUTHOR : J.KABWE

22-57-0522

#	PART #	Qty	TITLE
1	NC01-04-0107	2	CARR. BOLT GR2 ZINC 3/8-16 X 3/4"
2	01-01-2485	2	FLAT WASHER
3	NC02-32-0012	2	LOCK WASHER ZINC 3/8"
4	NC02-07-0018	2	HEX. NUT ZINC 3/8-16
5	22-57-0696	1	BELT GUARD " STICKER INCLUDED"

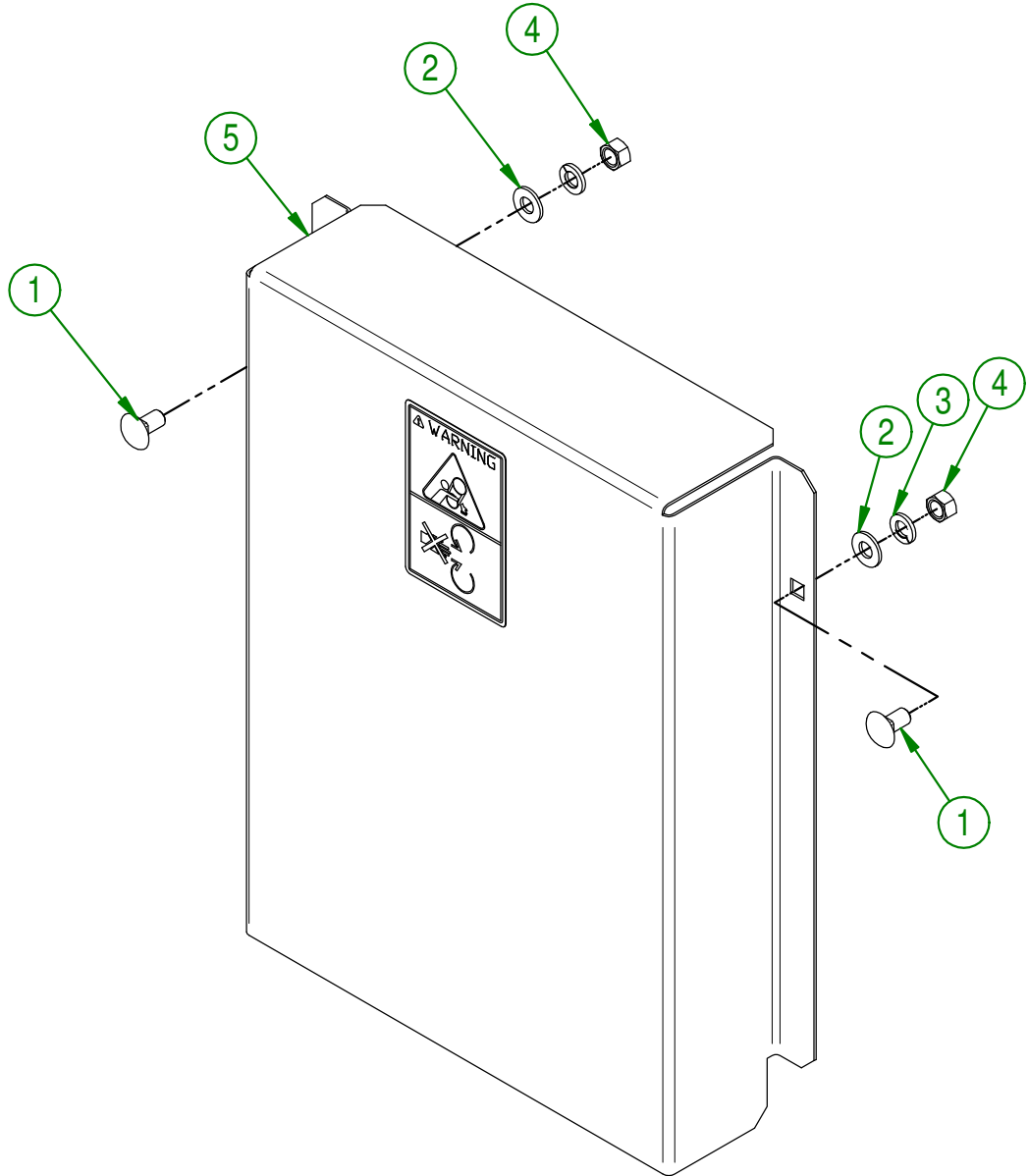

AGRIMETAL		
BELT GUARD GROUP		
CREATION : 2017-11-24	ASSEMBLY :	22-57-0522
REVISION : 2017-12-13	AUTHOR :	Page 12 de 70

#	PART #	Qty	TITLE
1	NC01-04-0107	16	CARR. BOLT GR2 ZINC 3/8-16 X 3/4"
2	01-01-2485	16	FLAT WASHER
3	NC02-32-0012	16	LOCK WASHER ZINC 3/8"
4	NC02-07-0018	16	HEX. NUT ZINC 3/8-16

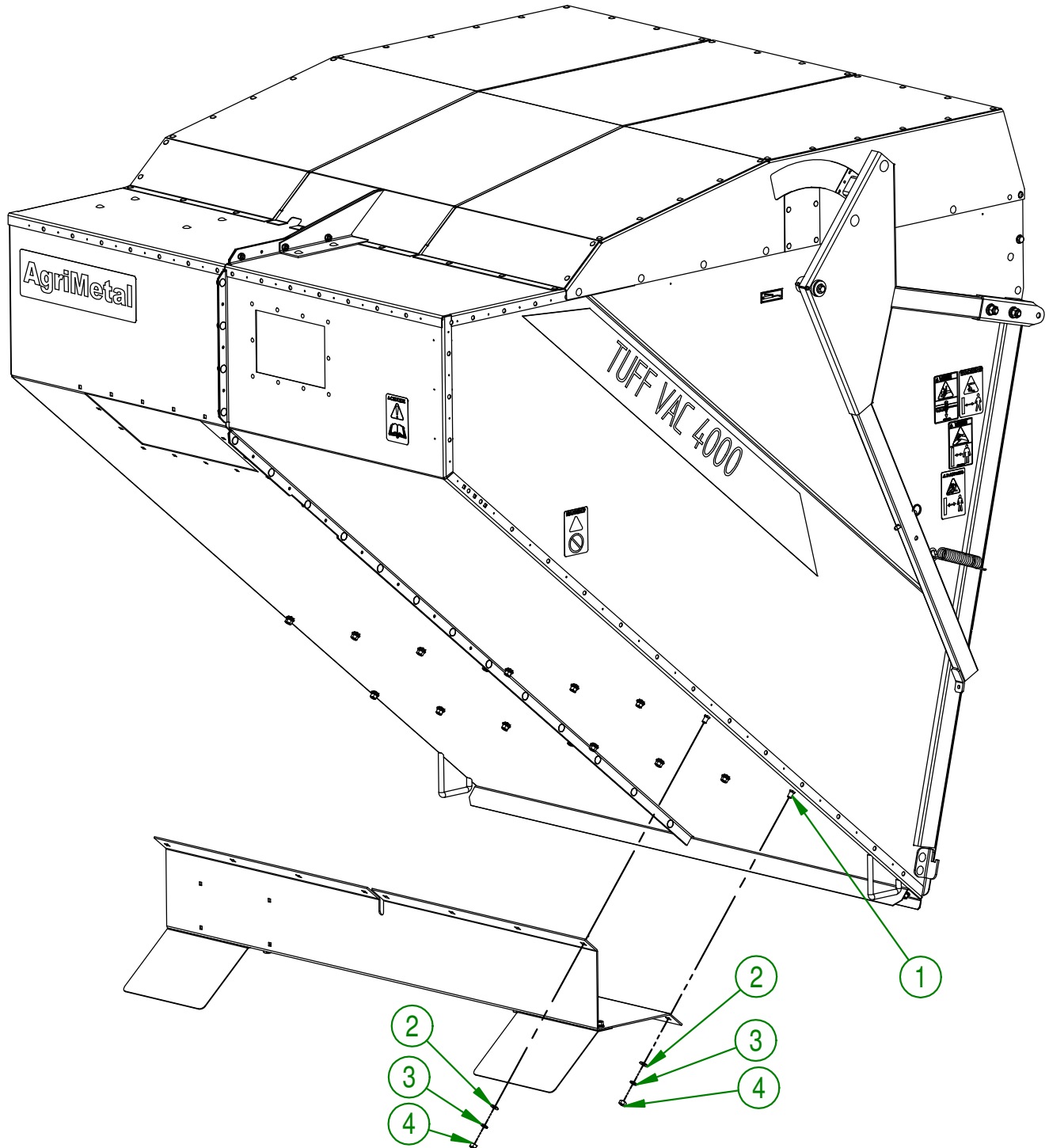

AGRIMETAL	
ASSEMBLY MAIN BOX	
CREATION : 13/10/16	ASSEMBLY : 22-57-0537
REVISION : 13/12/17	AUTHOR : F.HÉLIE Page 13 de 70

#	PART #	Qty	TITLE
1	22-01-1000	1	BOX SUPPORT
2	NC01-17-0248	4	HEX. BOLT GR2 ZINC 1/2-13 X 1 1/4"
3	01-01-0925	8	WASHER
4	NC02-32-0014	4	LOCK WASHER ZINC 1/2"
5	NC02-07-0020	4	HEX. NUT ZINC 1/2-13
6	22-01-2415	2	WHEEL FENDER
7	NC01-04-0107	6	CARR. BOLT GR2 ZINC 3/8-16 X 3/4"
8	01-01-2485	6	FLAT WASHER
9	NC02-32-0012	6	LOCK WASHER ZINC 3/8"
10	NC02-07-0018	6	HEX. NUT ZINC 3/8-16

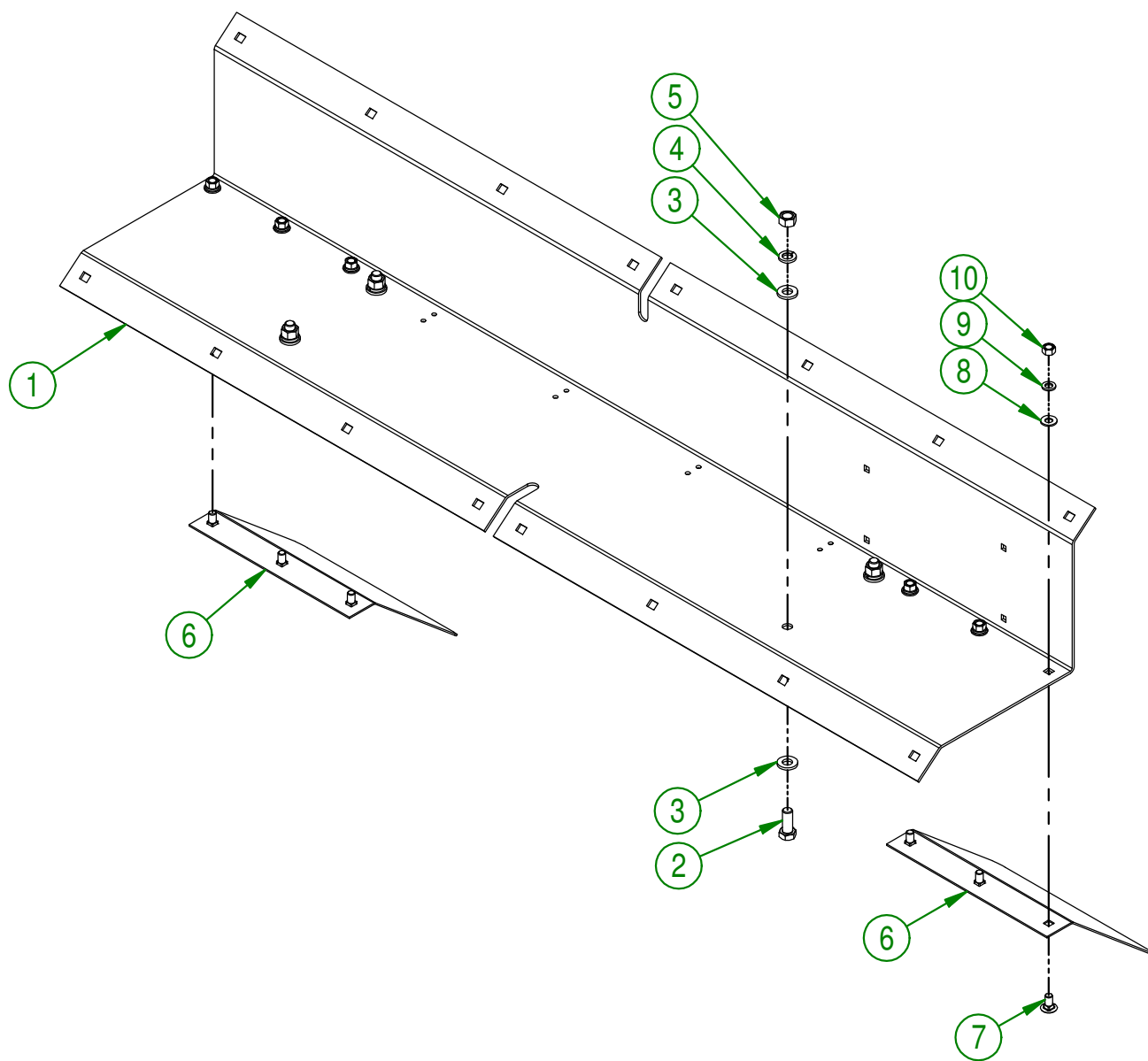

AGRIMETAL	
ASSEMBLY FENDER	
CREATION : 2016-10-19	ASSEMBLY : 22-57-0065
REVISION : 2018-05-04	AUTHOR : S.B. Page 14 de 70

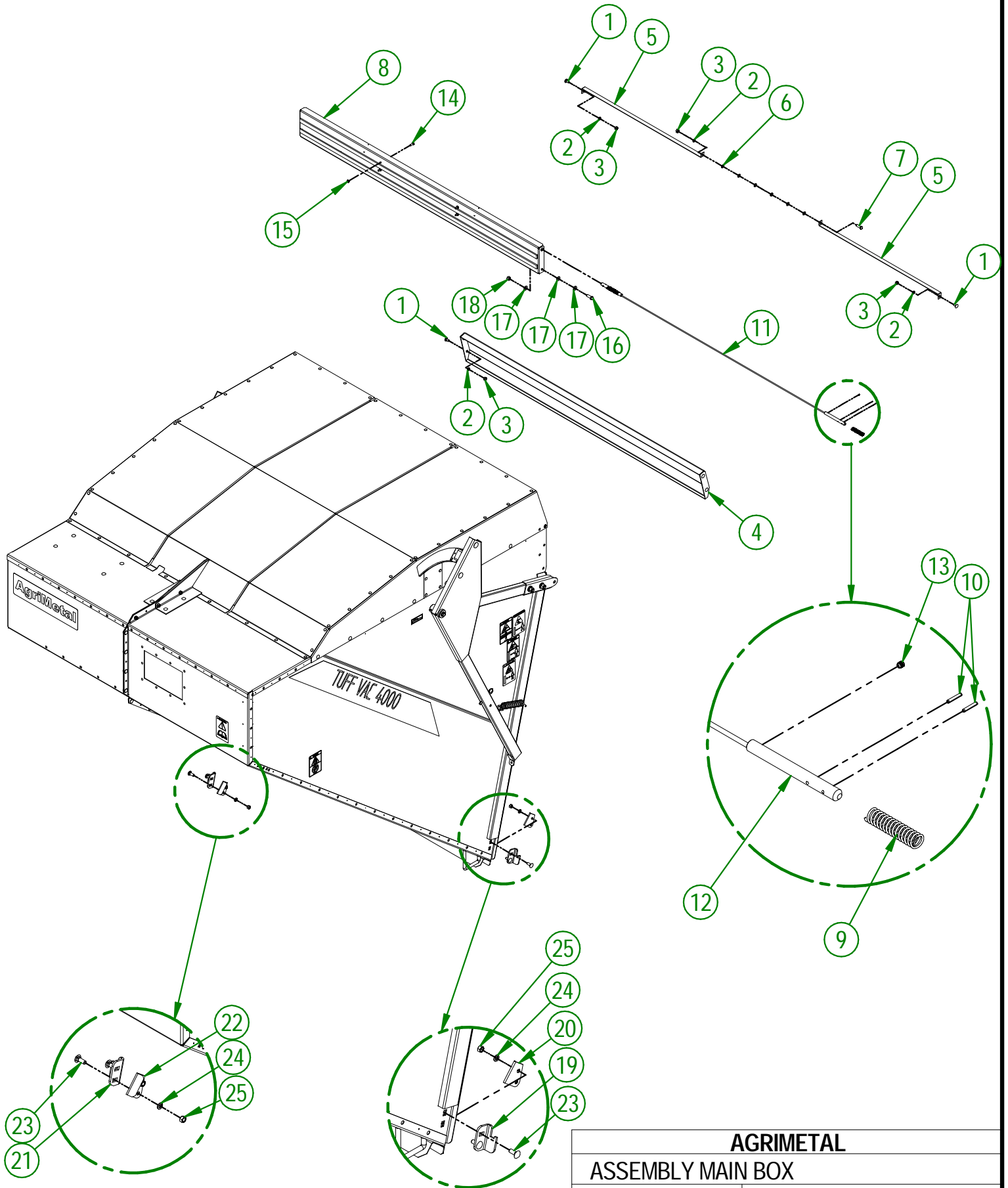

AGRIMETAL	
ASSEMBLY MAIN BOX	
CREATION : 2016-10-13	ASSEMBLY : 22-55-0575
REVISION : 2023-02-09	AUTHOR : S.B.

#	PART #	Qty	TITLE
1	NC01-04-0055	6	CARR. BOLT GR2 ZINC 5/16-18 X 5/8"
2	NC02-32-0011	7	LOCK WASHER ZINC 5/16"
3	NC02-07-0017	7	HEX. NUT 5/16-18
4	22-57-0660	1	CHANNEL CROSS MEMBER BOX GROUP
5	22-01-3110	2	FILTER RETAINER
6	NC02-22-0008	6	WASHER ZINC 5/16"
7	NC01-17-0060	1	BOLT HEX. GR2 ZINC 5/16-18 X 1"
8	22-57-0655	1	FILTER DOOR
9	NC13-85-0025	2	COMPRESSION SPRING
10	NC01-69-0377	4	CUTTER PIN ZINC 1/8" X 3/4"
11	22-41-0050	1	FILTER DOOR CABLE
12	22-13-0600	2	FILTER DOOR LOCK
13	NC02-44-0088	2	ALLENS SET SCREW 1/4-20 X 1/4" LG.
14	NC01-29-0003	4	HEX. BOLT GR5 ZINC 1/4-28 X 5/8"
15	NC02-14-0200	4	HEX. LOCK NUT THIN 1/4-20
16	NC01-17-0114	2	HEX. BOLT GR2 ZINC 3/8-16 X 1"
17	01-01-2485	6	FLAT WASHER
18	NC01-96-0011	2	NYLON NUT 3/8-16
19	22-04-6820	1	LEFT DOOR LATCH
20	22-01-3085	1	LEFT DOOR LATCH DEFLECTOR
21	22-04-0040	1	RIGHT DOOR LATCH
22	22-01-3080	1	RIGHT DOOR LATCH DEFLECTOR
23	NC01-04-0109	4	CARR. BOLT GR2 ZINC 3/8-16 X 1"
24	NC02-32-0012	4	LOCK WASHER ZINC 3/8"
25	NC02-07-0018	4	HEX. NUT ZINC 3/8-16

AGRIMETAL	
ASSEMBLY MAIN BOX	
CREATION : 2016-10-13	ASSEMBLY : 22-55-0575
REVISION : 2023-02-09	AUTHOR : S.B.

#	PART #	Qty	TITLE
1	NC01-04-0055	6	CARR. BOLT GR2 ZINC 5/16-18 X 5/8"
2	NC02-32-0011	7	LOCK WASHER ZINC 5/16"
3	NC02-07-0017	7	HEX. NUT 5/16-18
4	22-57-0660	1	CHANNEL CROSS MEMBER BOX GROUP
5	22-01-3110	2	FILTER RETAINER
6	NC02-22-0008	6	WASHER ZINC 5/16"
7	NC01-17-0060	1	BOLT HEX. GR2 ZINC 5/16-18 X 1"
8	22-57-0655	1	FILTER DOOR
9	NC13-85-0025	2	COMPRESSION SPRING
10	NC01-69-0377	4	CUTTER PIN ZINC 1/8" X 3/4"
11	22-41-0050	1	FILTER DOOR CABLE
12	22-13-0600	2	FILTER DOOR LOCK
13	NC02-44-0088	2	ALLENS SET SCREW 1/4-20 X 1/4" LG.
14	NC01-29-0003	4	HEX. BOLT GR5 ZINC 1/4-28 X 5/8"
15	NC02-14-0200	4	HEX. LOCK NUT THIN 1/4-20
16	NC01-17-0114	2	HEX. BOLT GR2 ZINC 3/8-16 X 1"
17	01-01-2485	6	FLAT WASHER
18	NC01-96-0011	2	NYLON NUT 3/8-16
19	22-04-6820	1	LEFT DOOR LATCH
20	22-01-3085	1	LEFT DOOR LATCH DEFLECTOR
21	22-04-0040	1	RIGHT DOOR LATCH
22	22-01-3080	1	RIGHT DOOR LATCH DEFLECTOR
23	NC01-04-0109	4	CARR. BOLT GR2 ZINC 3/8-16 X 1"
24	NC02-32-0012	4	LOCK WASHER ZINC 3/8"
25	NC02-07-0018	4	HEX. NUT ZINC 3/8-16

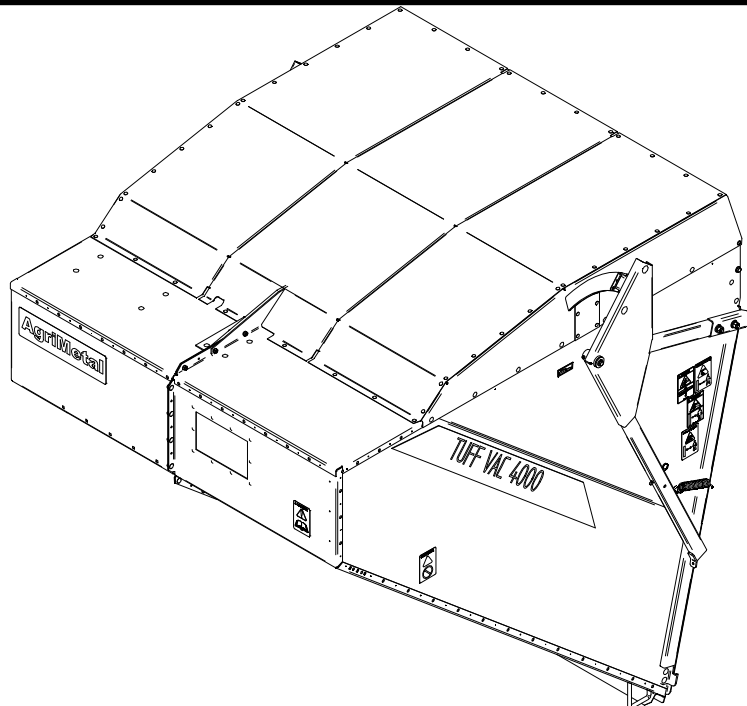
**AGRIMETAL****ASSEMBLY MAIN BOX**

CREATION : 2016-10-13	ASSEMBLY :	22-55-0575
REVISION : 2017-12-13	AUTHOR : S.B.	Page 16 de 70

#	PART #	Qty	TITLE
1	22-55-0195	1	CYLINDER
2	22-13-1420	1	CYLINDER PIN
3	22-13-1415	1	CYLINDER PIN
4	NC01-17-0114	4	HEX. BOLT GR2 ZINC 3/8-16 X 1"
5	04-33-0225	4	FLAT WASHER 1 1/2" DIA. X 1"
6	04-33-0220	2	FLAT WASHER 1 1/2" DIA. X 1"
7	NC02-32-0012	4	LOCK WASHER ZINC 3/8"
8	01-33-0010	4	WASHER
9	NC13-45-0391	2	STRAIGHT UNION

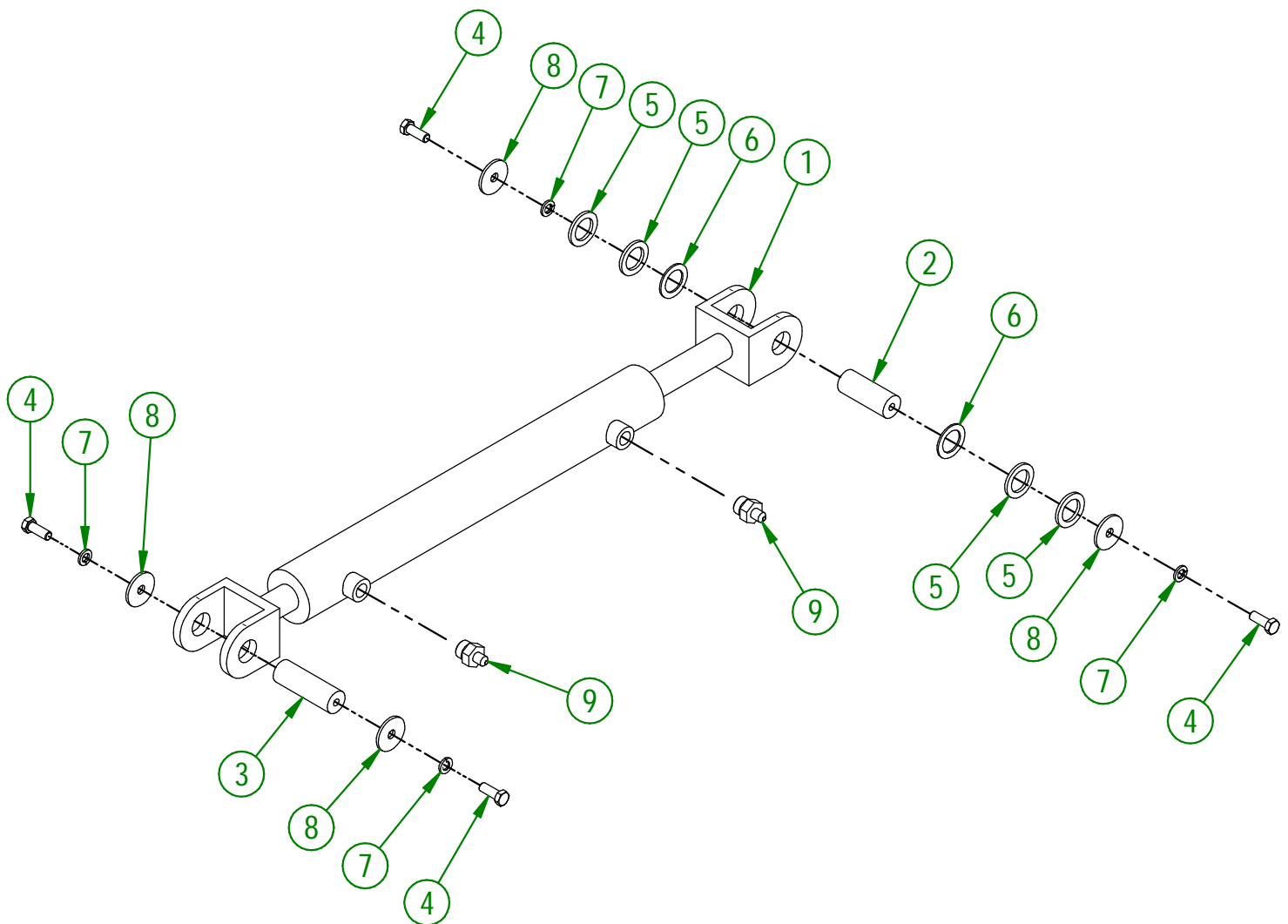

AGRIMETAL	
ASSEMBLY HYDRAULIC CYLINDER	
CREATION : 21/07/17	ASSEMBLY : 22-57-0225
REVISION : 24/04/23	AUTHOR : F.HÉLIE

#	PART #	Qty	TITLE
1	22-50-0120	1	CYLINDER ATTACHMENT
2	22-50-0140	1	ARM DOOR TRIANGLE (LEFT)
3	NC13-15-0051	4	O-RING
4	22-50-0145	1	ARM DOOR TRIANGLE (RIGHT)
5	NC01-04-0233	4	CARR. BOLT GR2 ZINC 1/2-13 X 1"
6	NC02-32-0014	10	LOCK WASHER ZINC 1/2"
7	NC02-07-0020	8	HEX. NUT ZINC 1/2-13
8	NC01-17-0114	2	HEX. BOLT GR2 ZINC 3/8-16 X 1"
9	01-33-0010	2	WASHER
10	NC01-69-0785	2	STRAIGHT GREASE FITTING 1/4-28
11	22-01-1170	2	DOOR SUPPORT
12	NC01-04-0237	4	CARR. BOLT GR2 ZINC 1/2-13 X 2"
13	NC02-25-0011	4	WASHER SAE ZINC 17/32 ID
14	NC13-85-0026	2	SPRING GALVANIZED 0.120"W X 1.050"OD X 6"
15	NC01-69-1201	1	SAFETY PIN

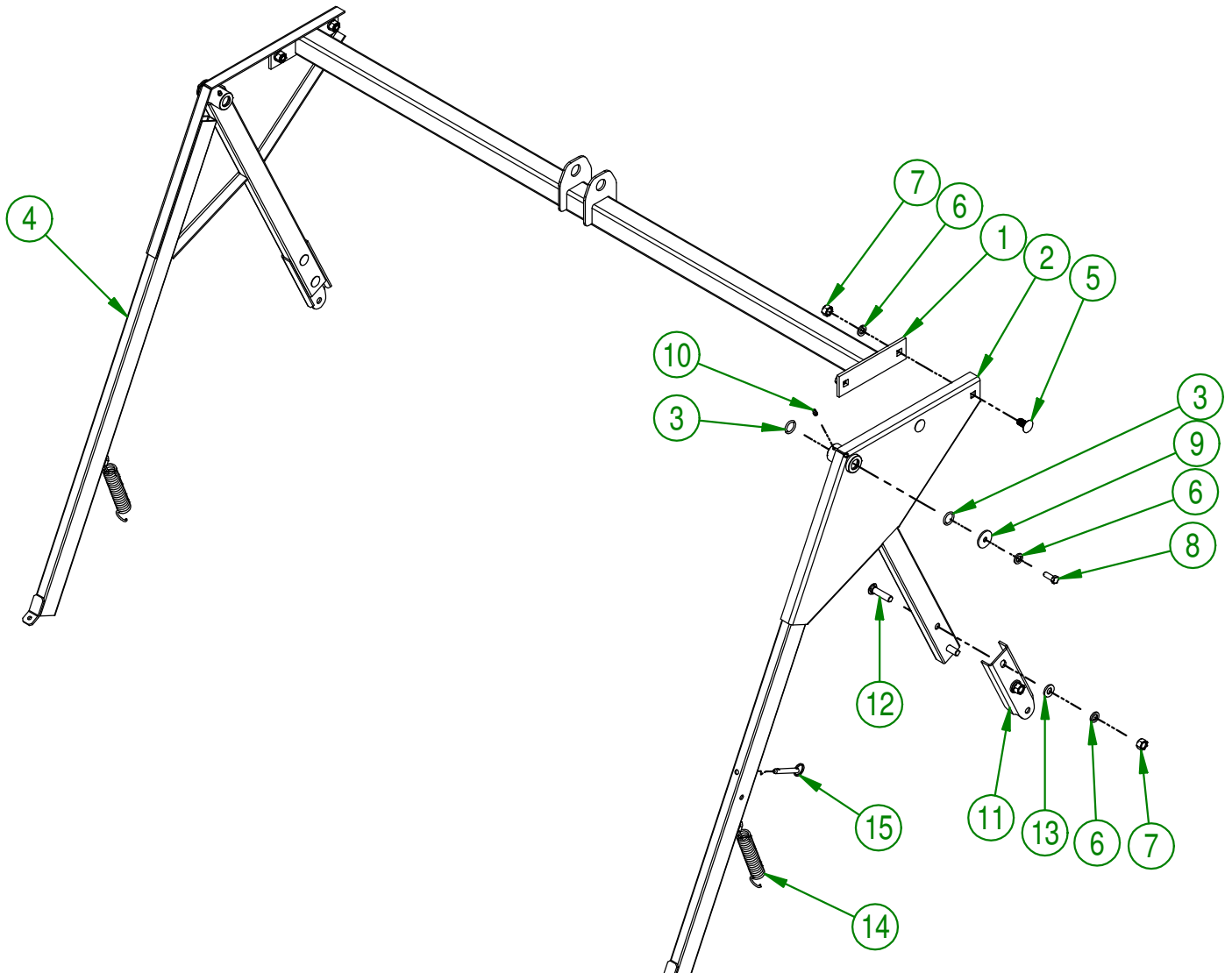

AGRIMETAL		
ASSEMBLY DOOR ARM TRIANGLE		
CREATION : 2016-10-13	ASSEMBLY :	22-57-0175
REVISION : 2018-05-04	AUTHOR :	Page 18 de 70

#	PART #	Qty	TITLE
1	22-01-7665	1	SCREEN HOLDER
2	22-01-7670	1	SCREEN CHANNEL HOLDER (LARGE)
3	22-01-7660	1	SCREEN CHANNEL HOLDER (SMALL)
4	NC01-04-0116	2	CARR. BOLT GR2 ZINC 3/8-16 X 2 3/4"
5	NC02-32-0012	2	LOCK WASHER ZINC 3/8"
6	NC02-07-0018	2	HEX. NUT ZINC 3/8-16

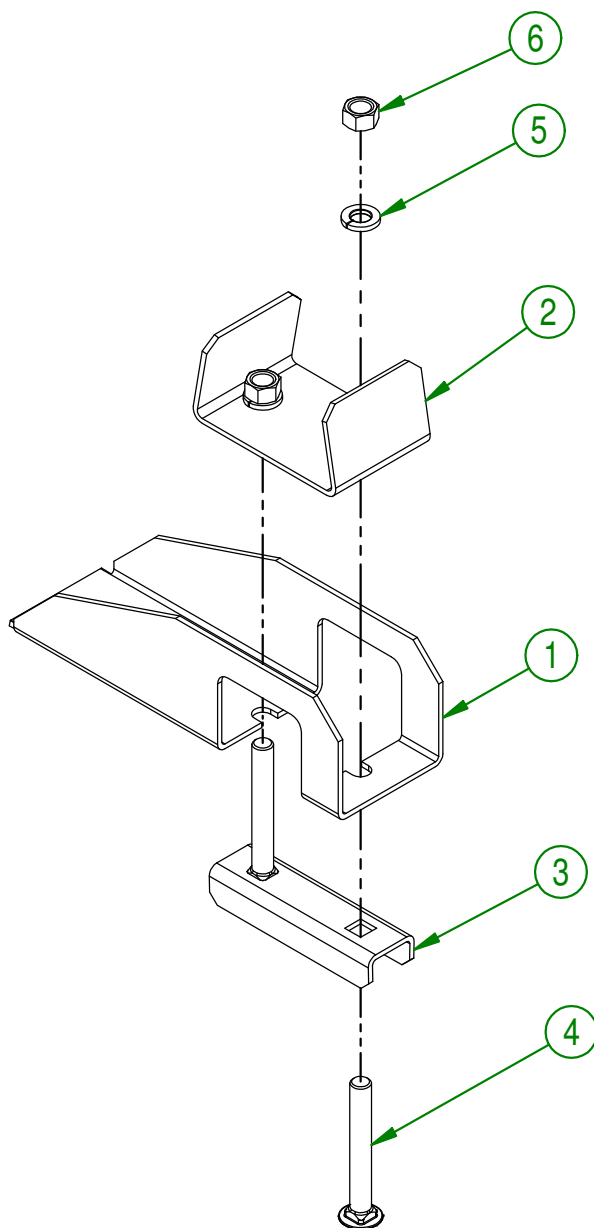

AGRIMETAL	
ASSEMBLY SCREEN HOLDER	
CREATION : 06/07/17	ASSEMBLY : 22-57-0235
REVISION : 04/05/18	AUTHOR : F.HÉLIE Page 19 de 70

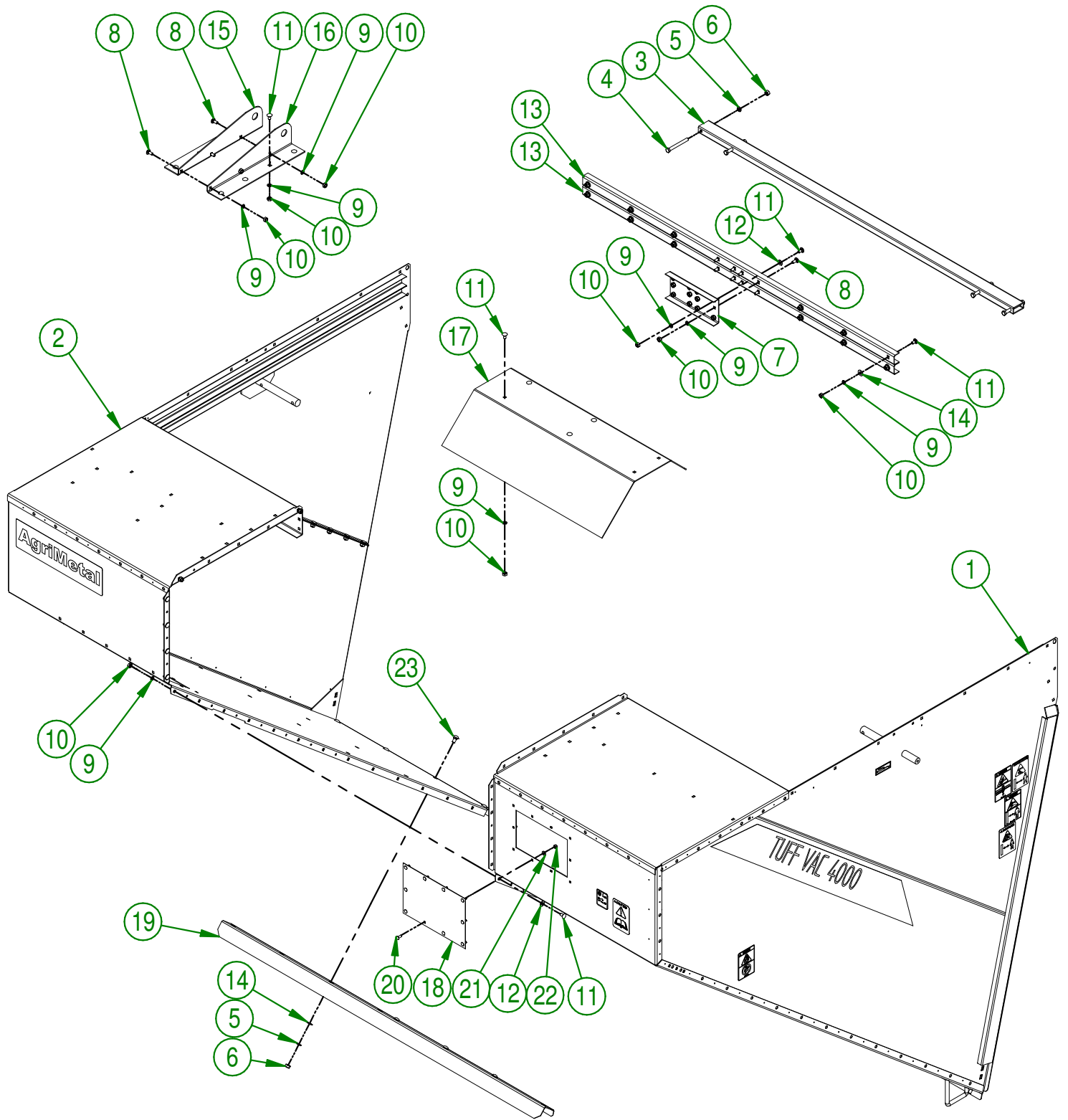

AGRIMETAL
ASSEMBLY SIDES BOX

CREATION : 21/07/17
 REVISION : 07/09/21

ASSEMBLY : **22-57-0600**
 AUTHOR : F.HÉLIE

#	PART #	Qty	TITLE
1	22-57-0665	1	LEFT BOX SIDE (GAZ) "STICKER INCLUDED"
2	22-57-0670	1	RIGHT BOX SIDE
3	22-08-3000	1	TUBE CROSS MEMBER
4	NC01-17-0124	4	HEX. BOLT GR2 ZINC 3/8-16 X 3 1/2"
5	NC02-32-0012	12	LOCK WASHER ZINC 3/8"
6	NC02-07-0018	12	HEX. NUT ZINC 3/8-16
7	22-01-2450	1	TOP BOX UNION PLATE
8	NC01-04-0056	13	CARR. BOLT 5/16-18 X3/4"
9	NC02-32-0011	58	LOCK WASHER ZINC 5/16"
10	NC02-07-0017	58	HEX. NUT 5/16-18
11	NC01-04-0055	45	CARR. BOLT GR2 ZINC 5/16-18 X 5/8"
12	22-22-2600	21	CARRIAGE BOLT SHIM (5/16")
13	22-01-2420	2	GRILL SUPPORT (FRONTAL)
14	01-01-2485	20	FLAT WASHER 14 GA X 13/16"OD X 25/64" ID
15	22-01-1080	1	RIGHT HYDRAULIC CYLINDER SUPPORT
16	22-01-1075	1	LEFT HYDRAULIC CYLINDER SUPPORT
17	22-01-7595	1	CHUTE DEFLECTOR
18	22-42-0000	1	CLEAR ACCESS DOOR
19	22-01-2495	1	CHANNEL CROSS MEMBER
20	NC01-04-0002	10	CARR. BOLT GR2 ZINC 1/4-20 X 5/8"
21	NC02-25-0007	10	WASHER ZINC 0.281 = 9/32
22	NC01-96-0009	10	NYLON-INSERT LOCKNUT ZINC 1/4-20
23	NC01-04-0107	8	CARR. BOLT GR2 ZINC 3/8-16 X 3/4"

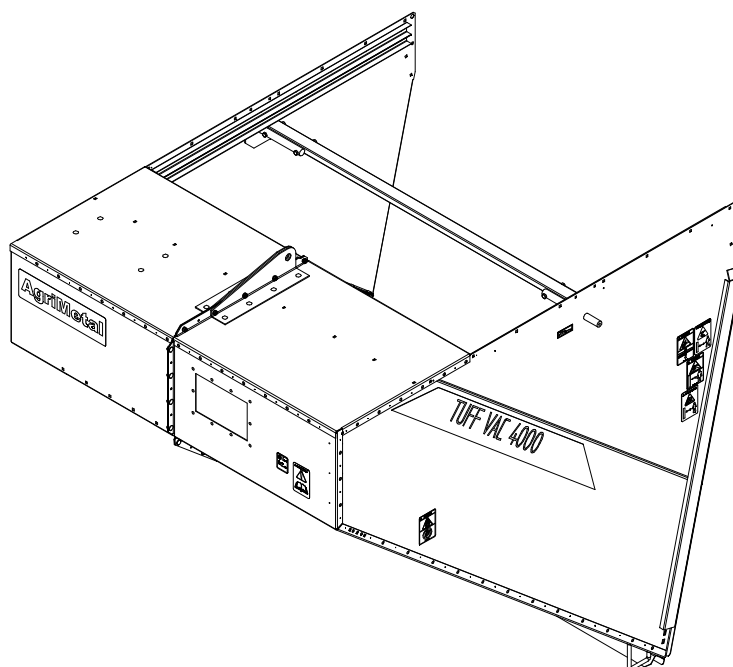

AGRIMETAL
ASSEMBLY SIDES BOX

CREATION : 21/07/17
REVISION : 07/09/21

ASSEMBLY : **22-57-0600**
AUTHOR : F.HÉLIE

#	PART #	Qty	TITLE
1	22-01-3045	2	DEFLECTOR DOOR
2	NC01-04-0002	16	CARR. BOLT GR2 ZINC 1/4-20 X 5/8"
3	NC01-96-0009	16	NYLON-INSERT LOCKNUT ZINC 1/4-20
4	22-01-2530	2	DEFLECTOR SIDE SHIM
5	NC01-04-0055	14	CARR. BOLT GR2 ZINC 5/16-18 X 5/8"
6	NC02-32-0011	14	LOCK WASHER ZINC 5/16"
7	NC02-07-0017	14	HEX. NUT 5/16-18
8	NC02-25-0007	12	WASHER ZINC 0.281 = 9/32

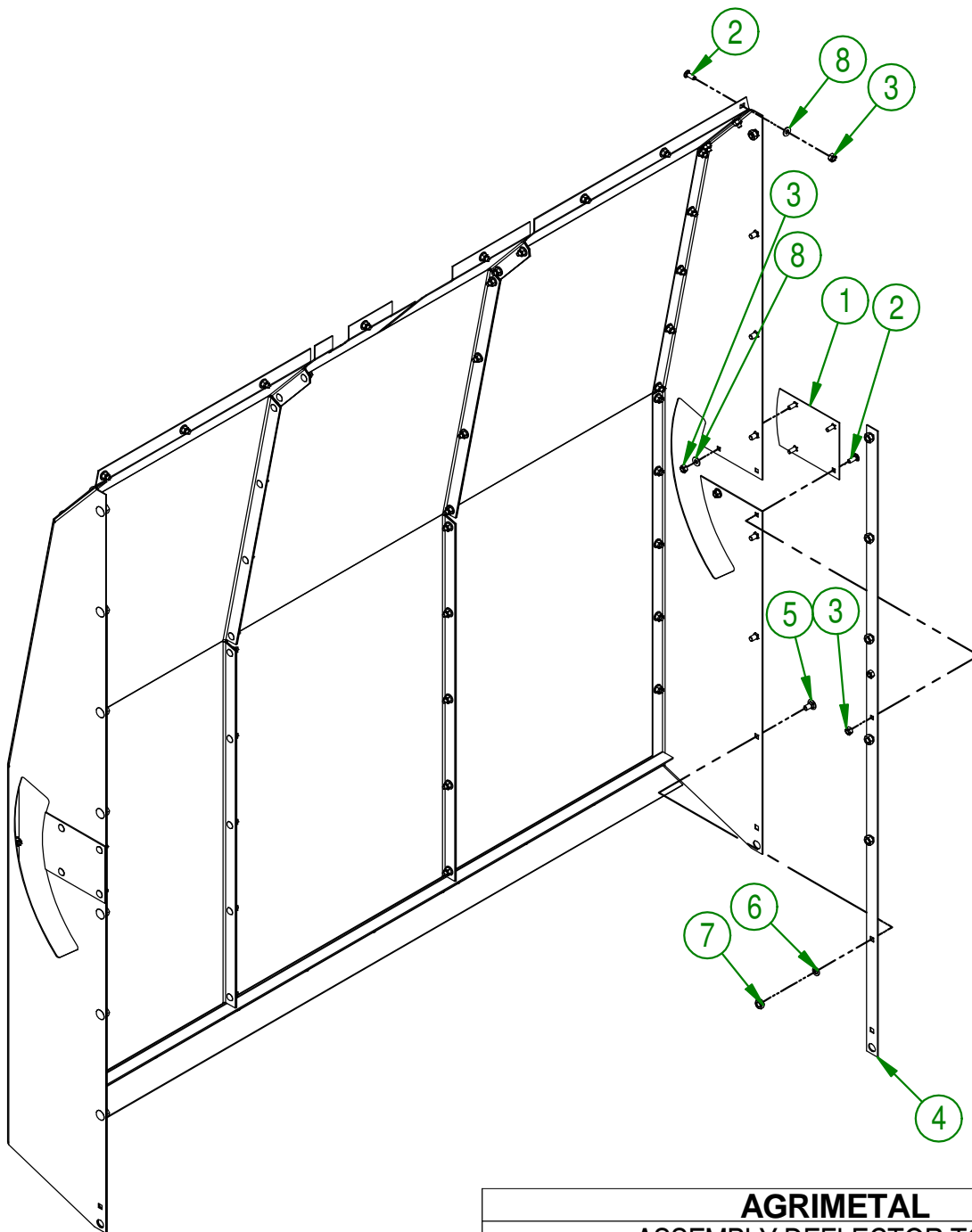

AGRIMETAL	
ASSEMBLY DEFLECTOR TOP	
CREATION : 12/07/17	ASSEMBLY : 22-57-0060
REVISION : 09/05/18	AUTHOR : F.HÉLIE Page 22 de 70

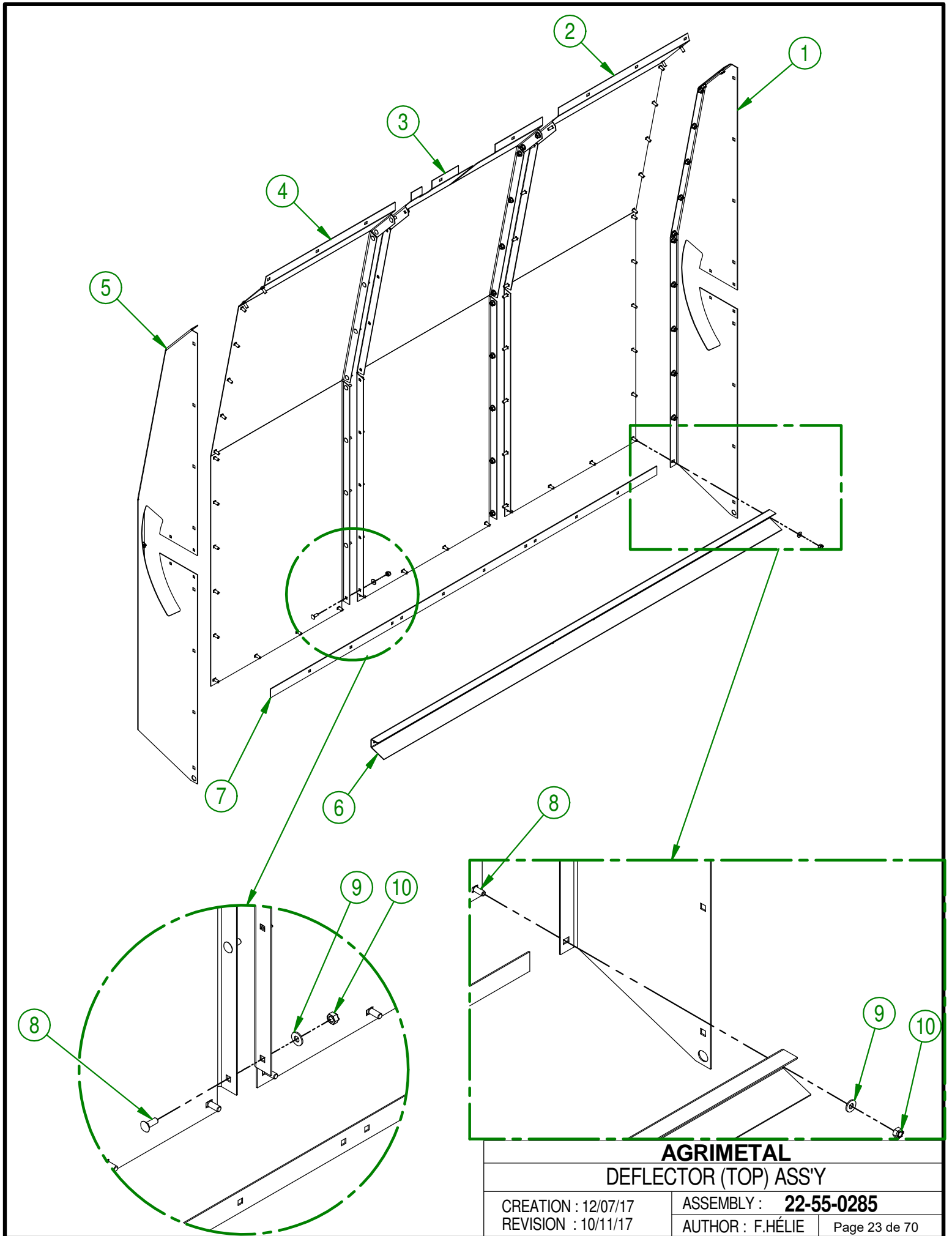

AGRIMETAL

DEFLECTOR (TOP) ASS'Y

CREATION : 12/07/17
 REVISION : 10/11/17

ASSEMBLY : **22-55-0285**

AUTHOR : F.HÉLIE

Page 23 de 70

#	PART #	Qty	TITLE
1	22-01-3030	1	LEFT DEFLECTOR SIDE
2	22-01-3040	1	LEFT DEFLECTOR TOP
3	22-01-3020	1	CENTRAL DEFLECTOR TOP
4	22-01-3025	1	RIGHT DEFLECTOR TOP
5	22-01-3035	1	RIGHT DEFLECTOR SIDE
6	22-01-2525	1	DEFLECTOR CHANNEL
7	22-01-3090	1	DEFLECTOR SHIM
8	NC01-04-0002	58	CARR. BOLT GR2 ZINC 1/4-20 X 5/8"
9	NC02-25-0007	58	WASHER ZINC 0.281 = 9/32
10	NC01-96-0009	58	NYLON-INSERT LOCKNUT ZINC 1/4-20

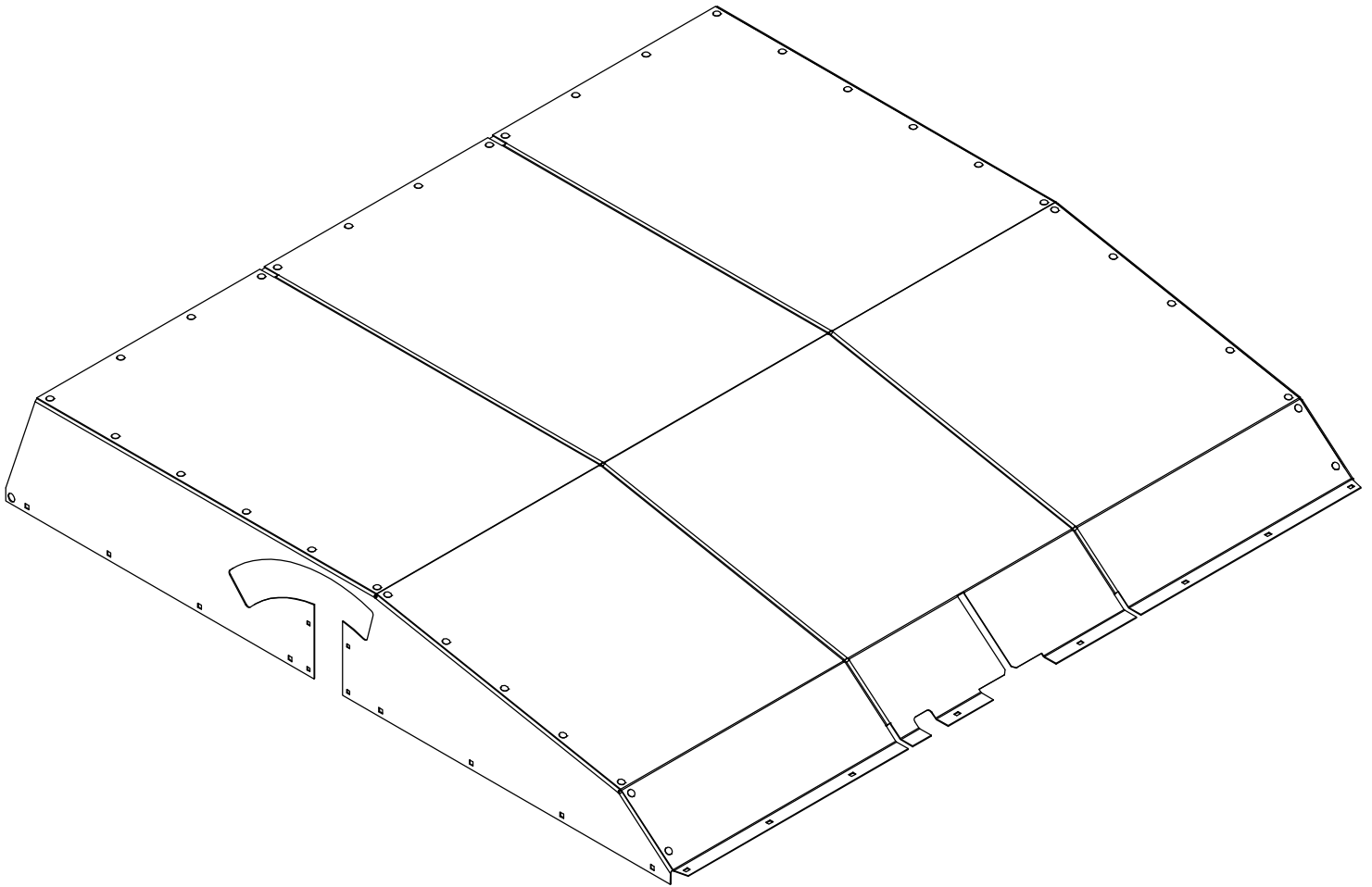

#	PART #	Qty	TITLE
1	22-55-0305	1	SEAL CONTENER (LEFT)
2	22-55-0315	1	SEAL CONTENER CLAMP
3	NC01-04-0014	2	BOLT CARR. GR2 ZINC 1/4-20 X 2 1/2"
4	NC01-96-0009	2	NYLON-INSERT LOCKNUT ZINC 1/4-20

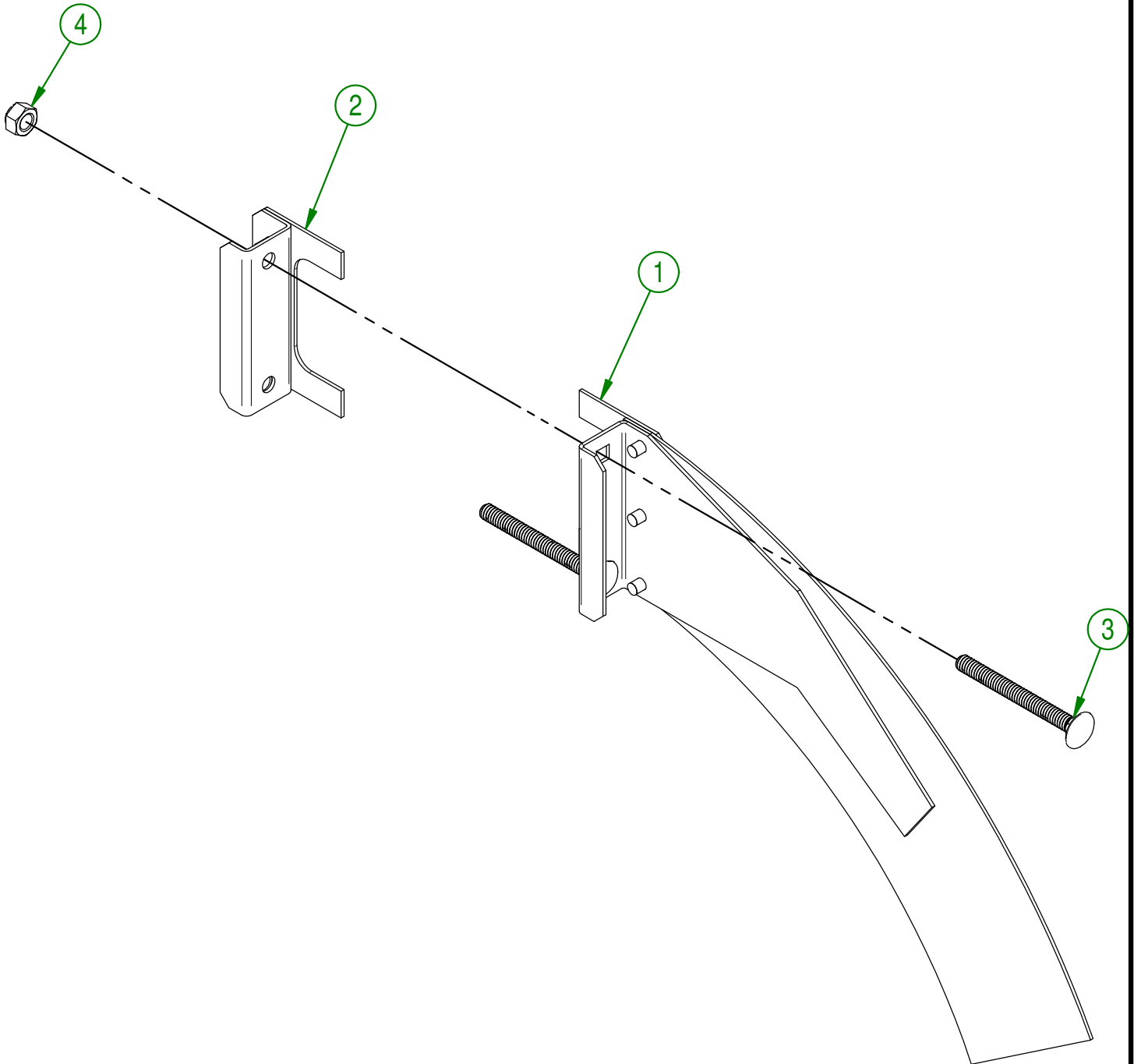

AGRIMETAL	
ASSEMBLY SEAL CONTENER LEFT	
CREATION : 08/08/17	ASSEMBLY : 22-57-0080
REVISION : 10/11/17	AUTHOR : F.HÉLIE Page 25 de 70

#	PART #	Qty	TITLE
1	22-55-0310	1	SEAL CONTENER (RIGHT)
2	22-55-0315	1	SEAL CONTENER CLAMP
3	NC01-04-0014	2	BOLT CARR. GR2 ZINC 1/4-20 X 2 1/2"
4	NC01-96-0009	2	NYLON-INSERT LOCKNUT ZINC 1/4-20

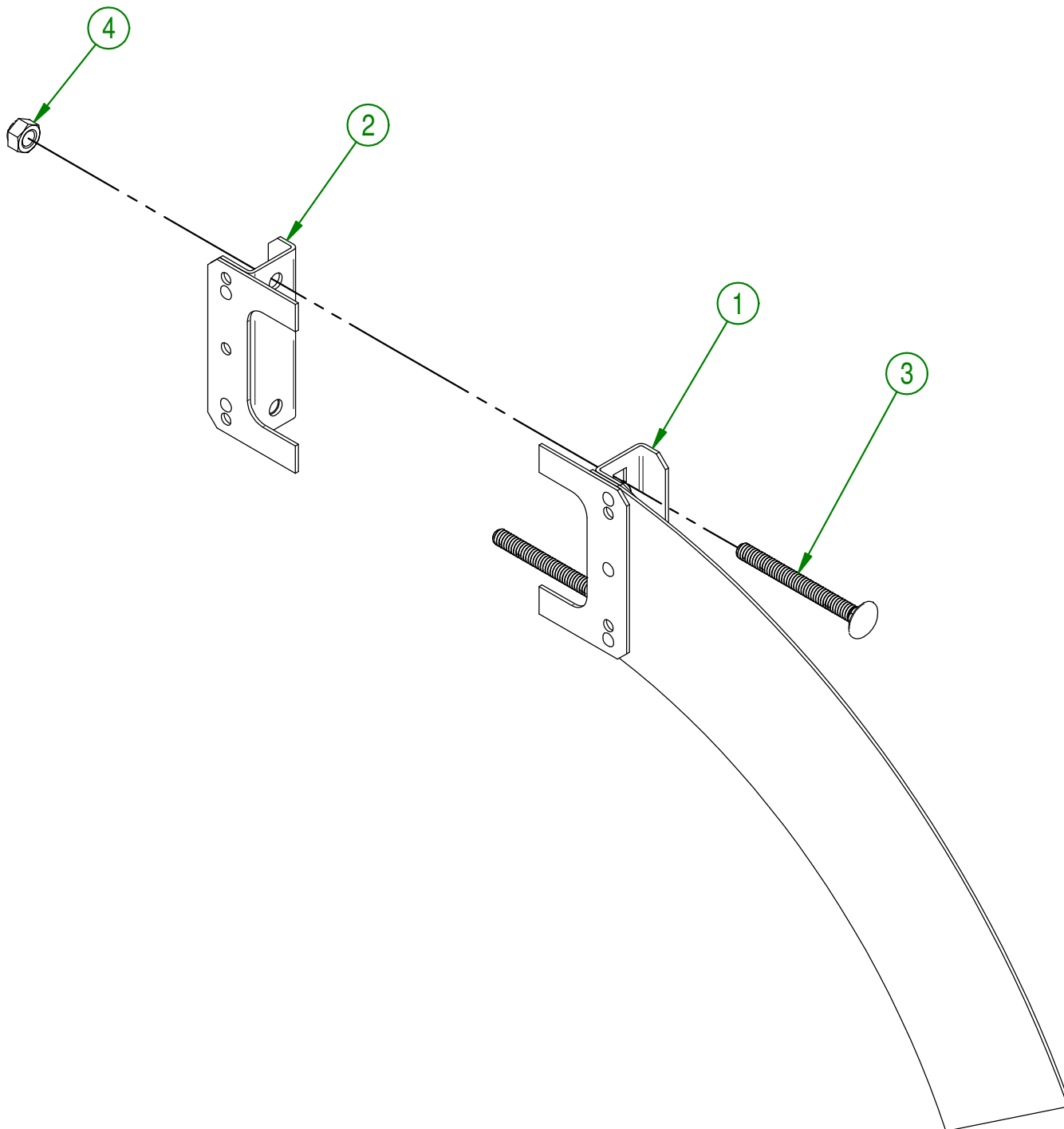

AGRIMETAL	
ASSEMBLY SEAL CONTENER RIGHT	
CREATION : 08/08/17	ASSEMBLY : 22-57-0085
REVISION : 10/11/17	AUTHOR : F.HÉLIE Page 26 de 70

#	PART #	Qty	TITLE
1	22-01-2430	1	BATTERY SUPPORT
2	22-21-0010	2	RUBBER STRAP HOLDER
3	NC01-04-0058	2	CARR. BOLT 5/16-18 X 0.625
4	NC01-96-0010	2	NYLON NUT HEX. ZINC 5/16-18
5	22-42-0205	1	SPONGE RUBAN
6	22-42-0210	2	SPONGE RUBAN
7	NCI3-12-0001	1	12 VOLTS BATTERY
8	NCI3-15-0008	1	RUBBER STRAP
9	NC01-04-0056	4	CARR. BOLT 5/16-18 X3/4"
10	NC02-25-0007	4	WASHER ZINC 0.281 = 9/32
11	NC02-32-0011	4	LOCK WASHER ZINC 5/16"
12	NC02-07-0017	4	HEX. NUT 5/16-18
13	NCI3-80-0267	1	RED PROTECTOR FOR BATTERY POST
14	NCI3-80-0268	1	BLACK PROTECTOR FOR BATTERY POST

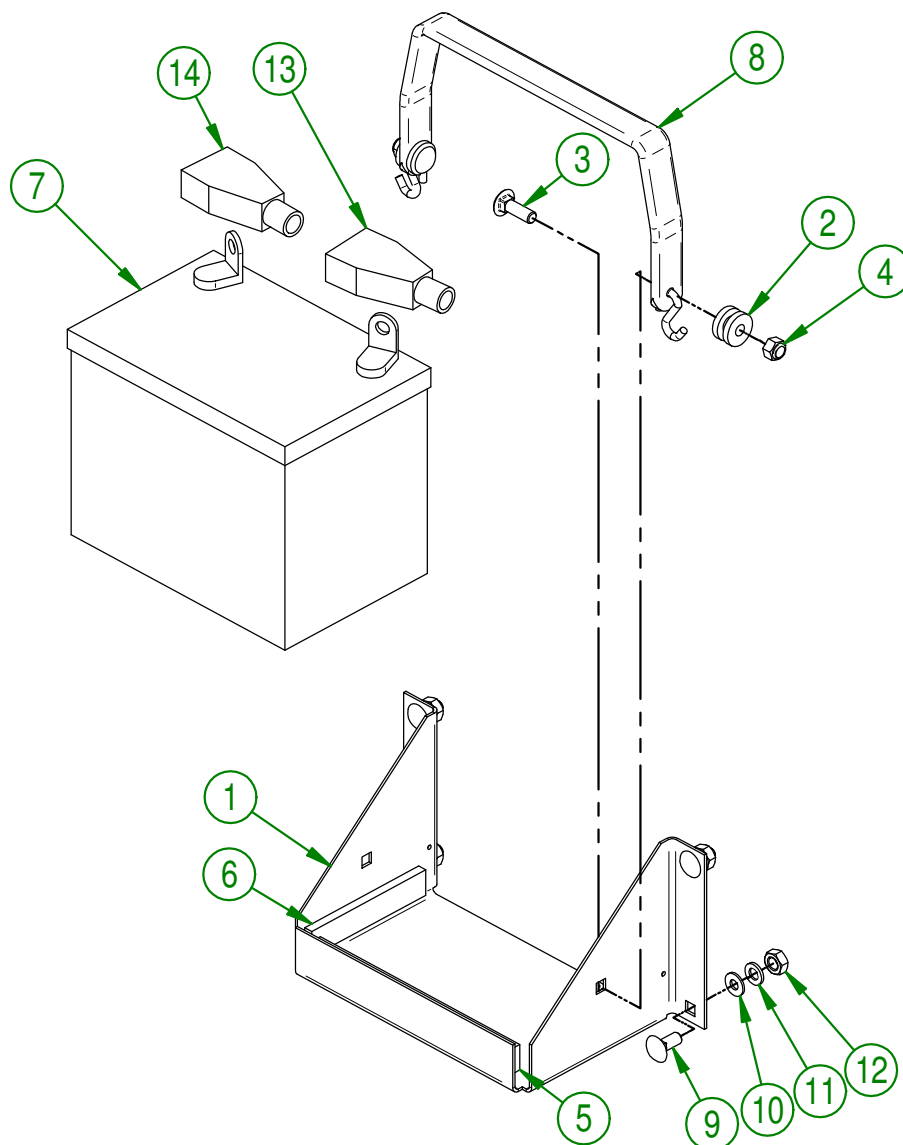

AGRIMETAL		
ASSEMBLY BATTERY		
CREATION : 2016-10-14	ASSEMBLY :	22-57-0505
REVISION : 2017-11-14	AUTHOR : S.B.	Page 27 de 70

#	PART #	Qty	TITLE
1	NC01-04-0055	11	CARR. BOLT GR2 ZINC 5/16-18 X 5/8"
2	NC02-32-0011	11	LOCK WASHER ZINC 5/16"
3	NC02-07-0017	11	HEX. NUT 5/16-18
4	NC01-04-0107	2	CARR. BOLT GR2 ZINC 3/8-16 X 3/4"
5	NC02-32-0012	6	LOCK WASHER ZINC 3/8"
6	NC02-07-0018	6	HEX. NUT ZINC 3/8-16
7	01-01-2485	6	FLAT WASHER 14 GA X 13/16"OD X 25/64" ID
8	22-57-0310	1	FRONT SIDE DUCT GROUP
9	22-01-2515	1	ACCESS DOOR
10	NC14-62-0089	1	PULLEY QD 2V 1/2-5/8 5.950D X SDS 2B56
11	NC14-62-0011	1	QD BUSHING 2B 5.6 OD SDS ØI 1/4 KW 1/4
12	01-41-0910	1	KEY
13	22-46-3750	1	GASKET

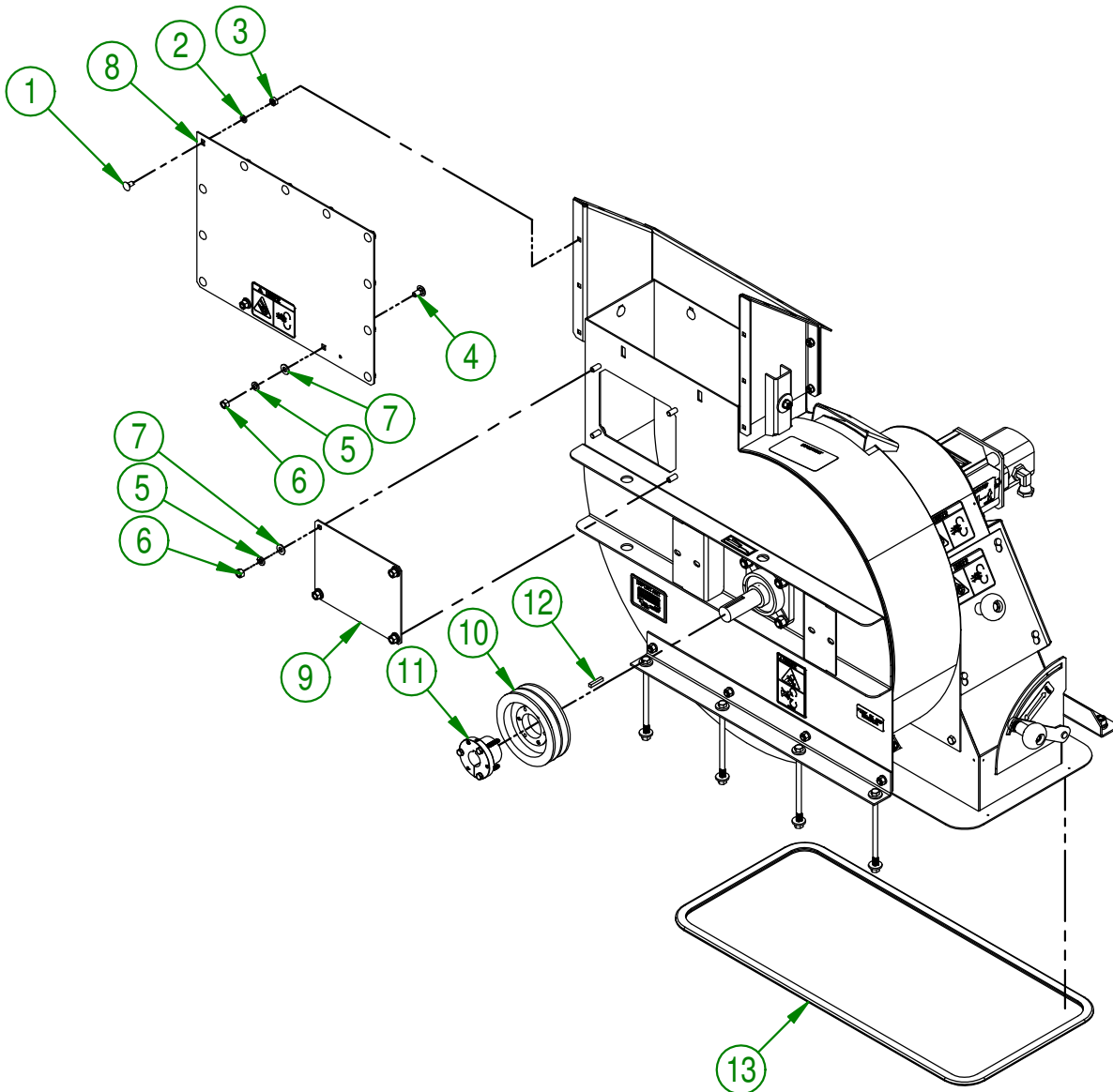
**AGRIMETAL****ASSEMBLY VACUUM BLOWER**

CREATION : 14-10-2016
 REVISION : 16-01-2019

ASSEMBLY : 22-57-0550
 AUTHOR :
 Page 28 de 70

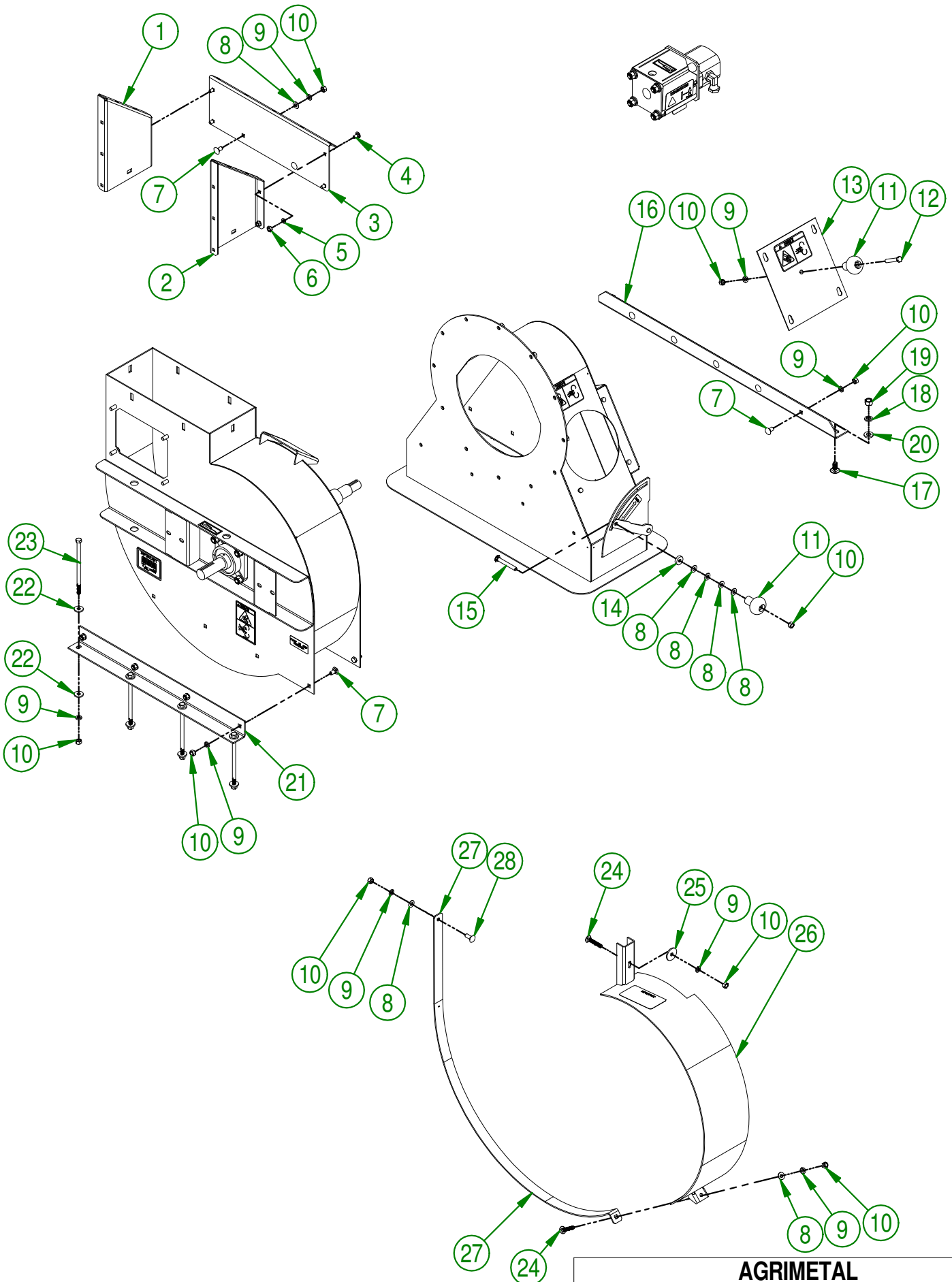

AGRIMETAL		
ASSEMBLY VACUUM BLOWER		
CREATION : 2016-10-14	ASSEMBLY :	22-55-0570
REVISION : 2017-12-14	AUTHOR :	Page 29 de 70

#	PART #	Qty	TITLE
1	22-01-7570	1	RIGHT SIDE DUCT
2	22-01-7575	1	LEFT SIDE DUCT
3	22-01-7585	1	BACK SIDE DUCT
4	NC01-04-0055	4	CARR. BOLT GR2 ZINC 5/16-18 X 5/8"
5	NC02-32-0011	4	LOCK WASHER ZINC 5/16"
6	NC02-07-0017	4	HEX. NUT 5/16-18
7	NC01-04-0107	11	CARR. BOLT GR2 ZINC 3/8-16 X 3/4"
8	01-01-2485	8	FLAT WASHER
9	NC02-32-0012	19	LOCK WASHER ZINC 3/8"
10	NC02-07-0018	20	HEX. NUT ZINC 3/8-16
11	NC17-46-0018	2	HANDLE KNOB
12	NC01-17-0119	1	HEX. BOLT GR2 ZINC 3/8-16 X 2 1/4"
13	22-57-0630	1	ACCESS DOOR "STICKER INCLUDED"
14	22-42-0100	1	U.H.M.W. FRICTION WASHER
15	NC01-04-0116	1	CARR. BOLT GR2 ZINC 3/8-16 X 2 3/4"
16	22-01-0940	1	BACK SUPPORT
17	NC01-04-0233	2	CARR. BOLT GR2 ZINC 1/2-13 X 1"
18	NC02-32-0014	2	LOCK WASHER ZINC 1/2"
19	NC02-07-0020	2	HEX. NUT ZINC 1/2-13
20	01-01-0925	2	WASHER
21	22-01-1110	1	FRONT SUPPORT
22	21-01-0950	8	FLAT WASHER 10GA 1.005" DIA X 25/64"
23	NC01-17-0138	4	HEX BOLT. GR2 NC ZINC 3/8-16 X 7" LG.
24	NC01-02-0113	2	CARR. BOLT GR2 ZINC 3/8-16 X 2"
25	01-33-0010	1	WASHER
26	22-57-0625	1	BLOWER HALF-CONTOUR GROUP " STICKER INCLUDED"
27	22-50-0175	1	BLOWER HALF-CONTOUR BELT
28	NC01-04-0109	1	CARR. BOLT GR2 ZINC 3/8-16 X 1"

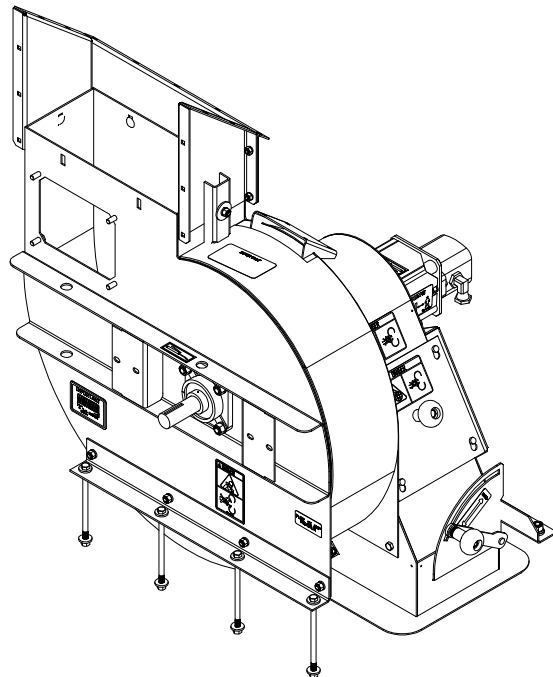

AGRIMETAL		
ASSEMBLY VACUUM BLOWER		
CREATION : 2016-10-14	ASSEMBLY :	22-55-0570
REVISION : 2017-12-14	AUTHOR :	Page 30 de 70

22-57-0545

#	PART #	Qty	TITLE
1	12-38-0001	1	FLANGE BEARING UCF 207-20
2	22-50-0097	1	IMPELLER
3	22-57-0635	1	BLOWER CASING
4	NC02-07-0020	4	HEX. NUT ZINC 1/2-13
5	NC02-32-0014	4	LOCK WASHER ZINC 1/2"

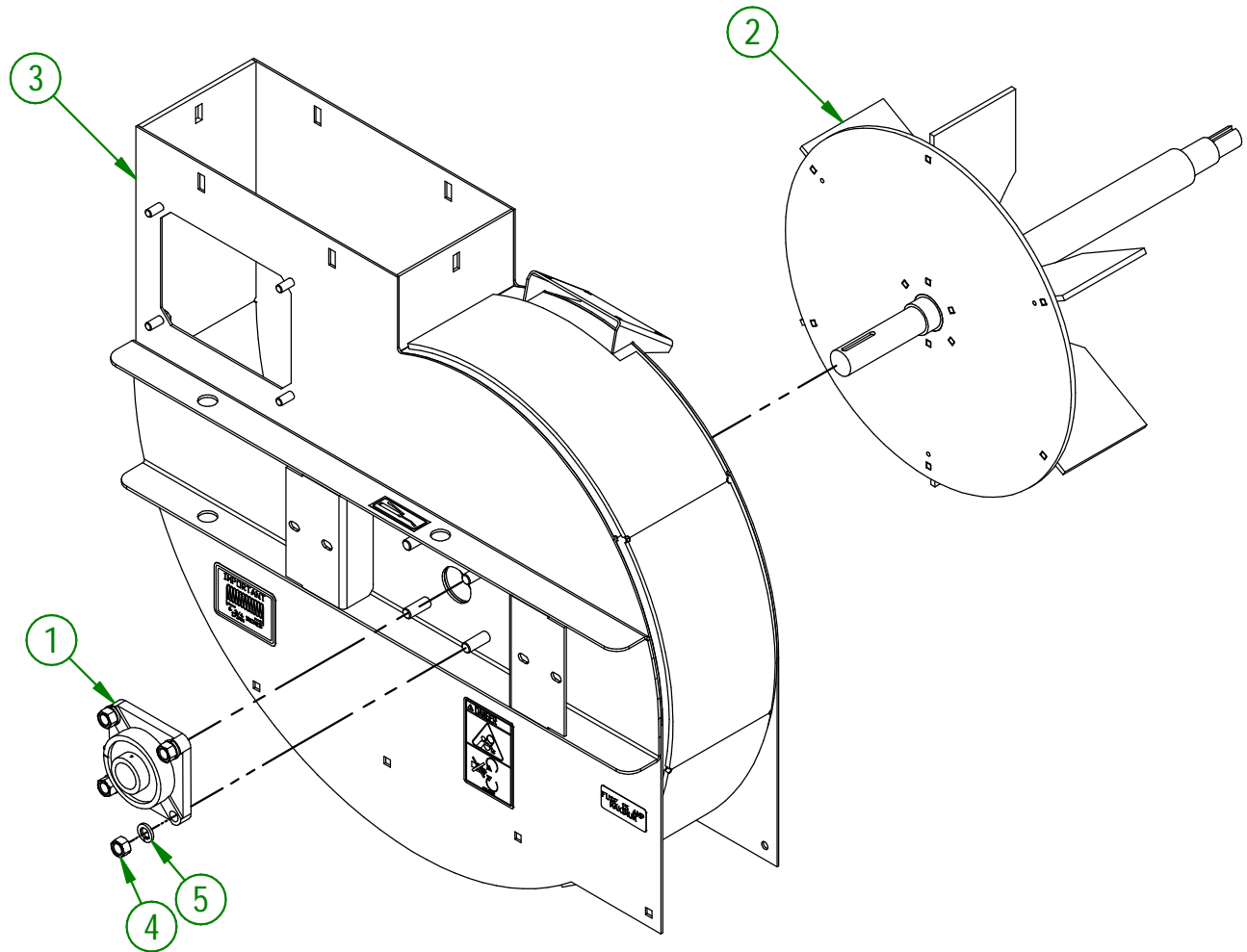

AGRIMETAL	
ASSEMBLY CASING BLOWER	
CREATION : 2025-12-02	ASSEMBLY : 22-57-0545
REVISION : 2025-12-02	AUTHOR : dessin3

#	PART #	Qty	TITLE
1	22-57-0640	1	ASSEMBLY SUCTION FUNNEL BOX "STICKER INCLUDED"
2	22-21-0000	7	TAPER WASHER
3	22-21-0015	2	TAPER WASHER SPECIAL
4	NC02-32-0012	16	LOCK WASHER ZINC 3/8"
5	NC02-07-0018	16	HEX. NUT ZINC 3/8-16
6	01-01-2485	7	FLAT WASHER

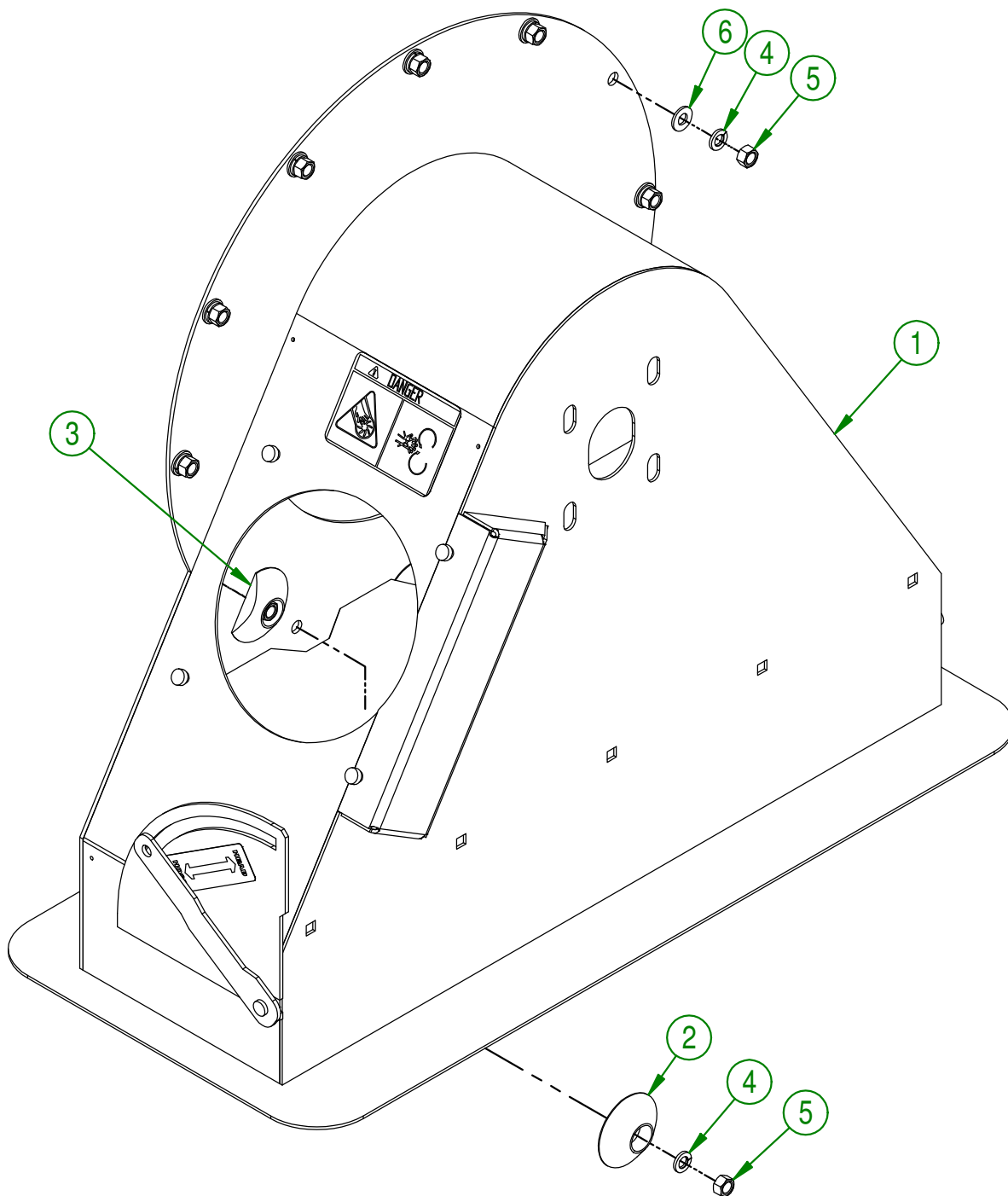

AGRIMETAL		
ASSEMBLY SUCTION FUNNEL BOX		
CREATION : 2016-10-14	ASSEMBLY :	22-57-0125
REVISION : 2018-05-04	AUTHOR : S.B.	Page 32 de 70

#	PART #	Qty	TITLE
1	NC14-45-0024	1	HYDRAULIC PUMP
2	16-04-6855	1	HYDRAULIC PUMP SUPPORT
3	NC01-17-0115	2	HEX. BOLT GR2 ZINC 3/8-16 X 1 1/4"
4	01-01-2485	2	FLAT WASHER
5	NC02-32-0012	2	LOCK WASHER ZINC 3/8"
6	NC02-07-0018	2	HEX. NUT ZINC 3/8-16
7	16-36-1800	1	SPROCKET #4016 X Ø3/4" KW 3/16" 2 SS 5/16-18
8	01-36-1815	1	SPROCKET #4016 X Ø1" KW 1/4" 2 SS 5/16-18
9	NC02-44-0103	4	SET SCREW 5/16-18 X 3/8"
10	NC14-20-0030	1	CHAIN 4016
11	16-30-9965	2	HYDRAULIC PUMP BOLT
12	NC01-17-0269	2	HEX. BOLT GR2 ZINC 1/2-13 X 6 1/2"
13	16-09-0800	4	LONG BUSING
14	NC02-25-0011	4	WASHER SAE ZINC 17/32 ID
15	NC02-32-0014	4	LOCK WASHER ZINC 1/2"
16	NC02-07-0020	4	HEX. NUT ZINC 1/2-13
17	16-38-0000	1	PILLOW BLOCK BEARING Ø1 1/4" UCF 207-20
18	NC13-45-0028	2	ELBOW 90° 7/8-14 MALE SAE O RING X 1/2 FEM NPT
19	22-55-0225	1	CHAIN COUPLING GUARD

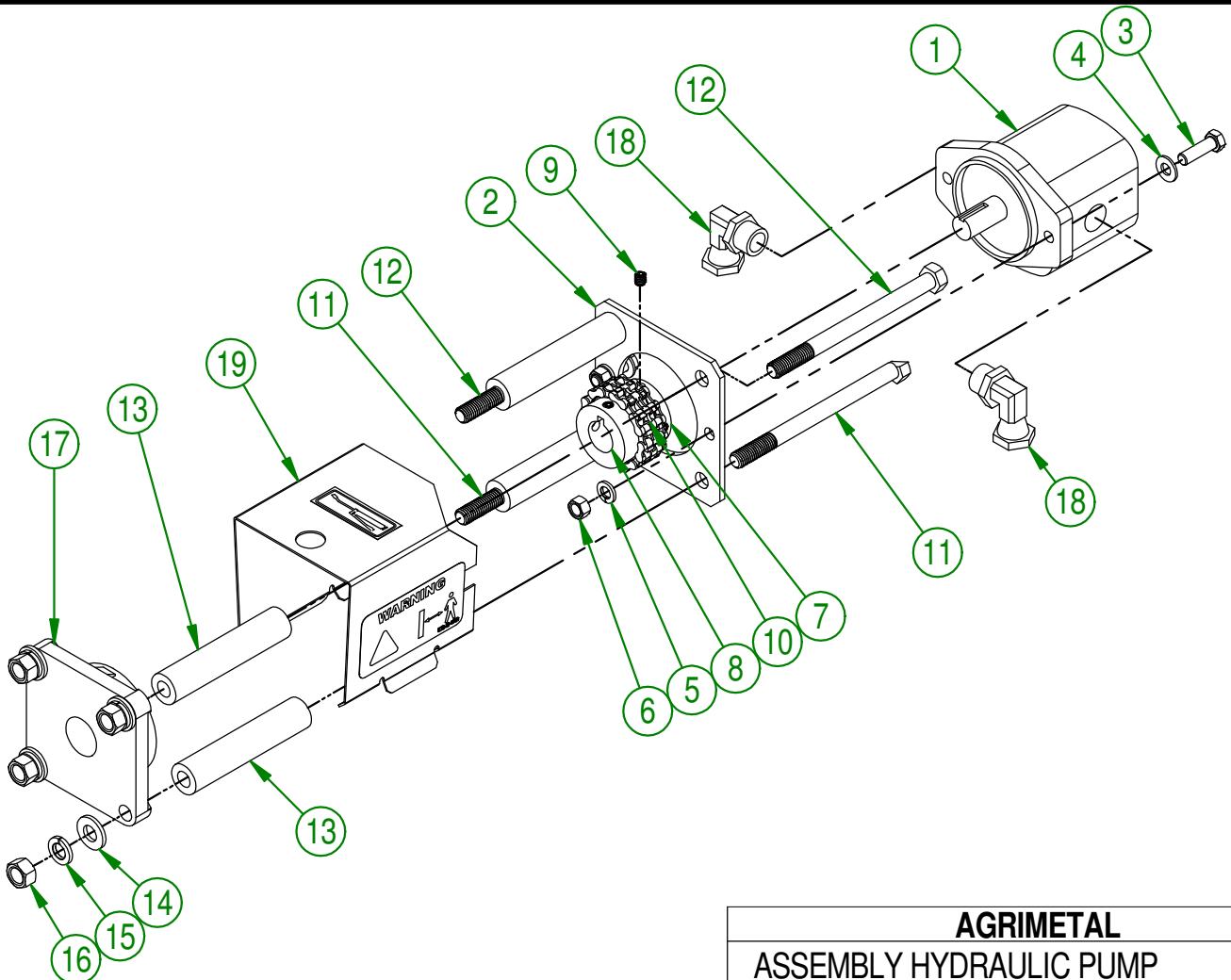

AGRIMETAL	
ASSEMBLY HYDRAULIC PUMP	
CREATION : 2016-10-14	ASSEMBLY : 22-57-0110
REVISION : 2018-05-09	AUTHOR : S.B. Page 33 de 70

#	PART #	Qty	TITLE
1	NC14-70-0074	1	ASSEMBLY AXEL
2	NC14-70-0077	2	ASSEMBLY WHEEL 23"
3	NC02-12-0005	10	HEX. NUT ZINC 1/2-20

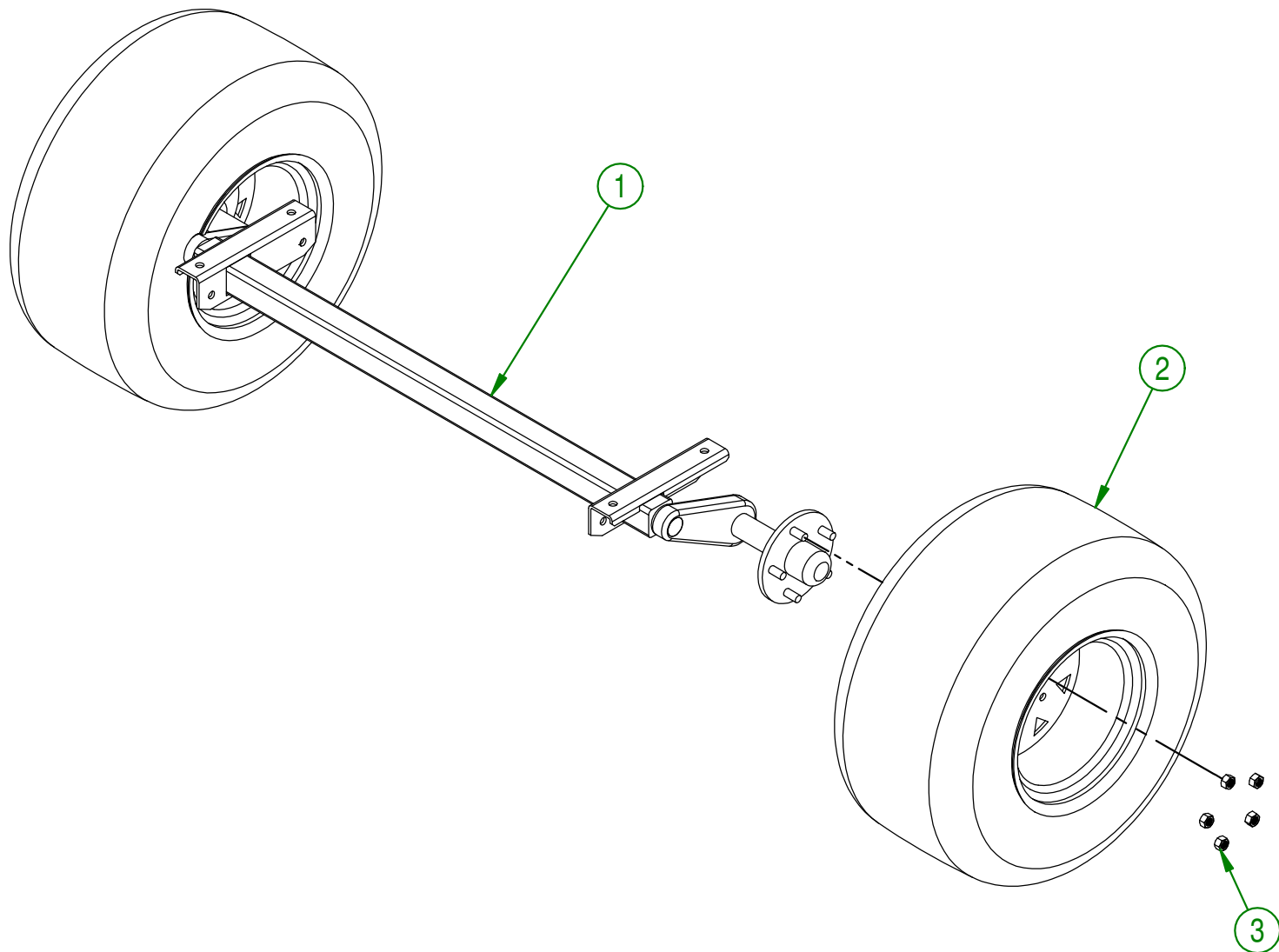

AGRIMETAL			
ASSEMBLY AXEL			
CREATION : 2016-10-14	ASSEMBLY :	22-57-0075	
REVISION : 2018-05-04	AUTHOR : S.B.	Page 34 de 70	

#	PART #	Qty	TITLE
1	NCI3-80-0248	1	GAS TANK
2	NCI3-80-0266	1	1/4" ON-OFF GAS VALVE
3	NCI3-80-0265	1	GROMMET VITRON #468661
4	NCI3-80-0247	1	GAS CAP
5	22-01-7725	1	GAS TANK SUPPORT
6	22-01-3185	1	FIXATION GAS TANK SUPPORT
7	NC01-04-0107	4	CARR. BOLT GR2 ZINC 3/8-16 X 3/4"
8	NC02-32-0012	4	LOCK WASHER ZINC 3/8"
9	NC02-07-0018	4	HEX. NUT ZINC 3/8-16
10	22-01-3195	2	STRAP GAS TANK
11	NC01-04-0002	4	CARR. BOLT GR2 ZINC 1/4-20 X 5/8"
12	NC02-25-0007	4	WASHER ZINC 0.281 = 9/32
13	NC01-96-0009	4	NYLON-INSERT LOCKNUT ZINC 1/4-20
14	NC01-65-0201	4	SPRING -GRIP HOSE CLAMPS 1/2" O.D
15	NCI3-15-0014	4	RUBBER WIRE WASHER
16	22-55-0512	1	GAZ LINE 1/4" DIA. X 46" LG.
17	NCI3-25-0110	1	SNUG-FIT DAMPING LOOP CLAMP
18	22-55-0513	1	GAZ LINE VAPOR 1/4" DIA. X 46" LG.
19	NCI3-25-0019	3	BLACK TIE RAP
20	NC01-78-0016	1	ALUMINIUM BLIND POP RIVET STEEL MANDREL 0.187 X 0.690

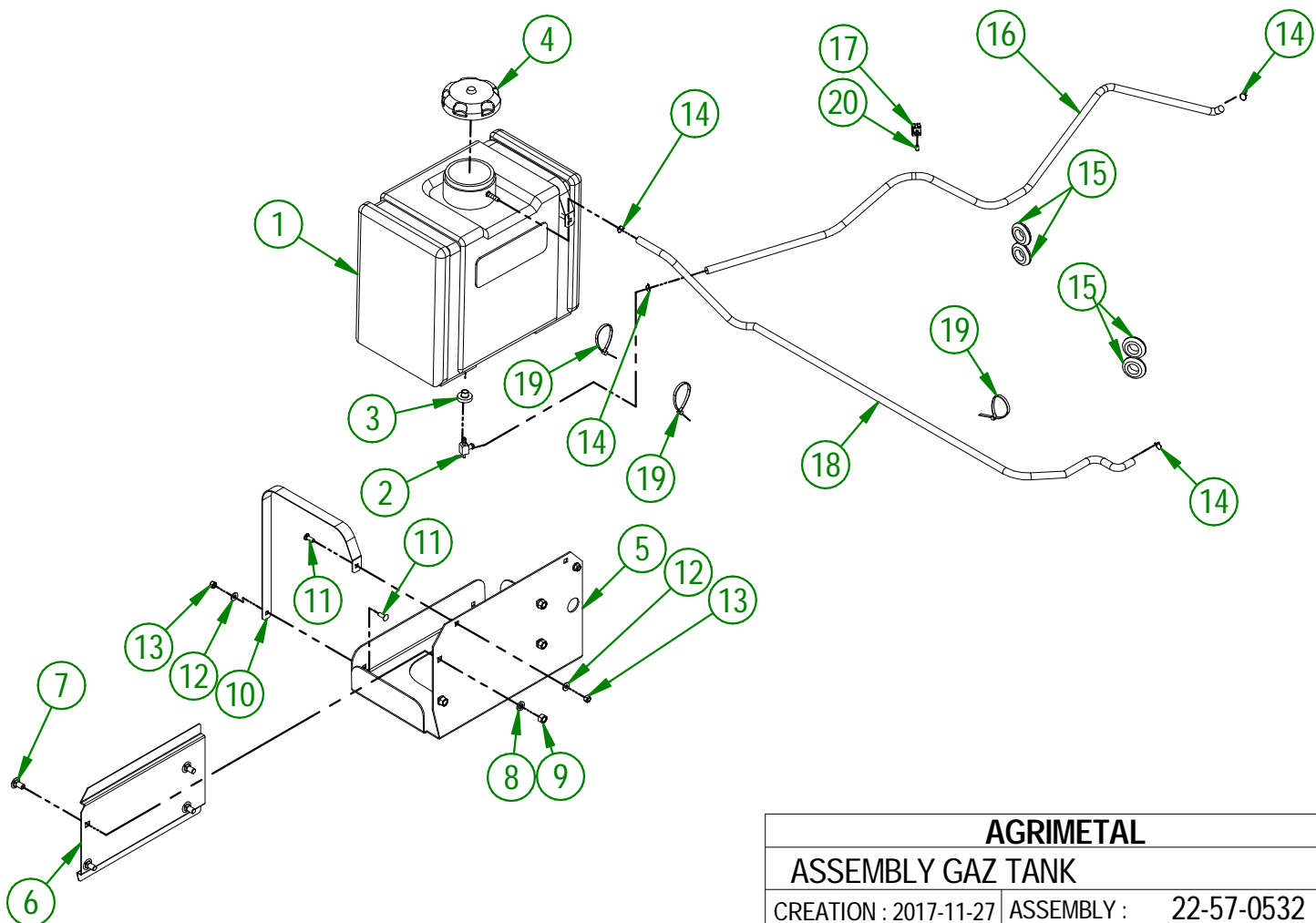

AGRIMETAL	
ASSEMBLY GAZ TANK	
CREATION : 2017-11-27	ASSEMBLY : 22-57-0532
REVISION : 2023-11-28	AUTHOR :

#	PART #	Qty	TITLE
1	22-01-3185	1	FIXATION GAS TANK SUPPORT
2	22-01-3195	2	STRAP GAS TANK
3	22-01-7725	1	GAS TANK SUPPORT
4	22-46-0100	1	GAZ LINE 1/4" DIA. X 50" LG.
5	22-46-0105	1	GAZ LINE VAPOR 1/4" DIA. X 46" LG.
6	22-46-0110	1	GAZ LINE 1/4" DIA. X 2" LG.
7	33-55-0200	1	GAS TANK
8	33-55-0205	1	GAS CAP </td
9	NC01-04-0002	4	CARR. BOLT GR2 ZINC 1/4-20 X 5/8"
10	NC01-04-0107	4	CARR. BOLT GR2 ZINC 3/8-16 X 3/4"
11	NC01-65-0201	6	SPRING -GRIP HOSE CLAMPS 1/2" O.D
12	NC01-78-0016	1	ALUMINIUM BLIND POP RIVET STEEL MANDREL 0.187 X 0.690
13	NC01-96-0009	4	NYLON-INSERT LOCKNUT ZINC 1/4-20
14	NC02-07-0018	4	HEX. NUT ZINC 3/8-16
15	NC02-25-0007	4	WASHER ZINC 0.281 = 9/32
16	NC02-32-0012	4	LOCK WASHER ZINC 3/8"
17	NCI3-15-0014	4	RUBBER WIRE WASHER
18	NCI3-25-0019	3	BLACK TIE RAP
19	NCI3-25-0110	1	SNUG-FIT DAMPING LOOP CLAMP
20	NCI3-80-0339	1	1/4" PRIMING BULB

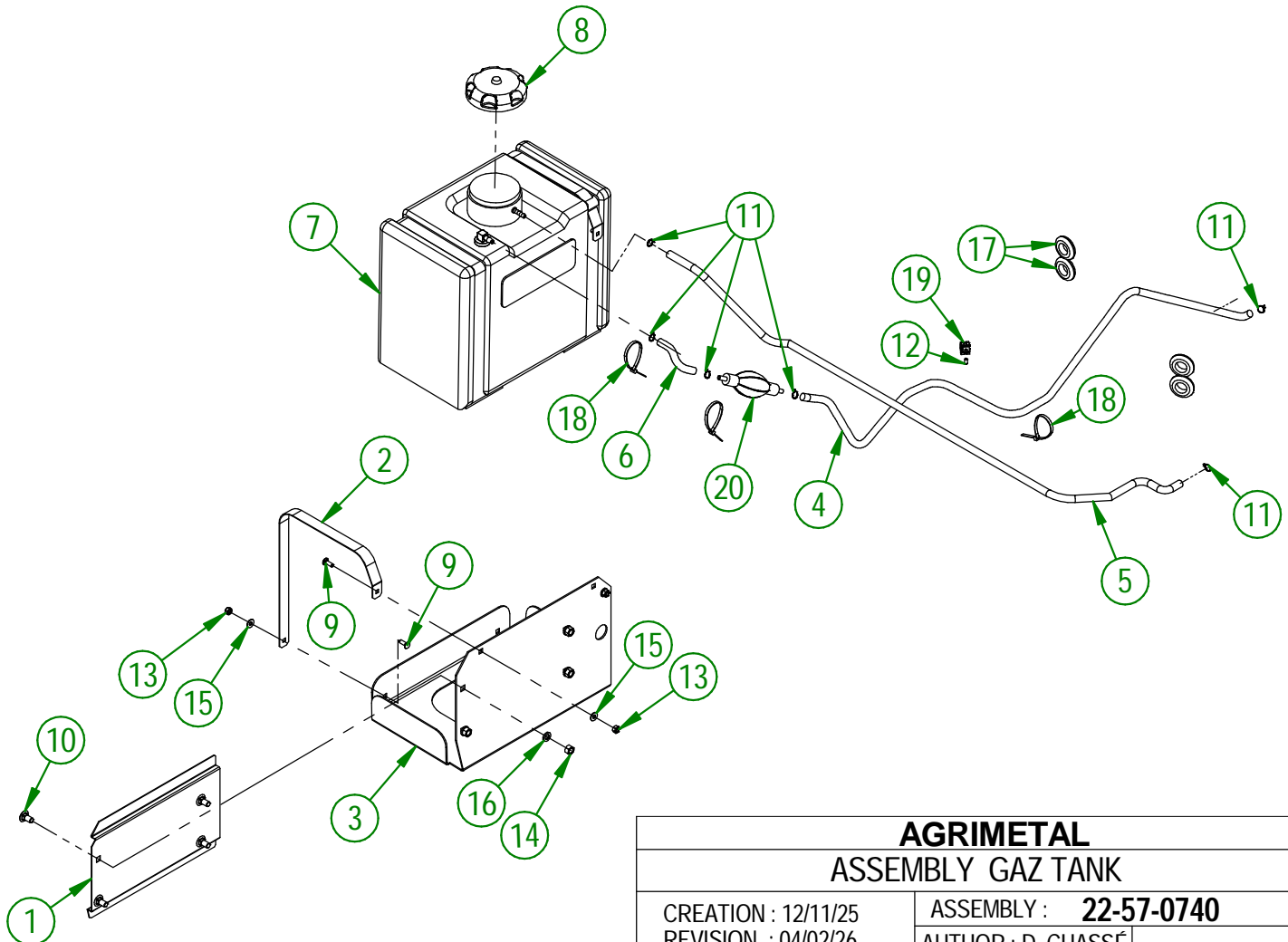

AGRIMETAL
ASSEMBLY GAZ TANK

CREATION : 12/11/25
REVISION : 04/02/26

ASSEMBLY : **22-57-0740**
AUTHOR : D. CHASSÉ

#	PART #	Qty	TITLE
1	22-50-0110	1	LEFT BOX SUPPORT
2	22-50-0115	1	RIGHT BOX SUPPORT
3	NC01-04-0055	12	CARR. BOLT GR2 ZINC 5/16-18 X 5/8"
4	NC02-32-0011	12	LOCK WASHER ZINC 5/16"
5	NC02-07-0017	12	HEX. NUT 5/16-18

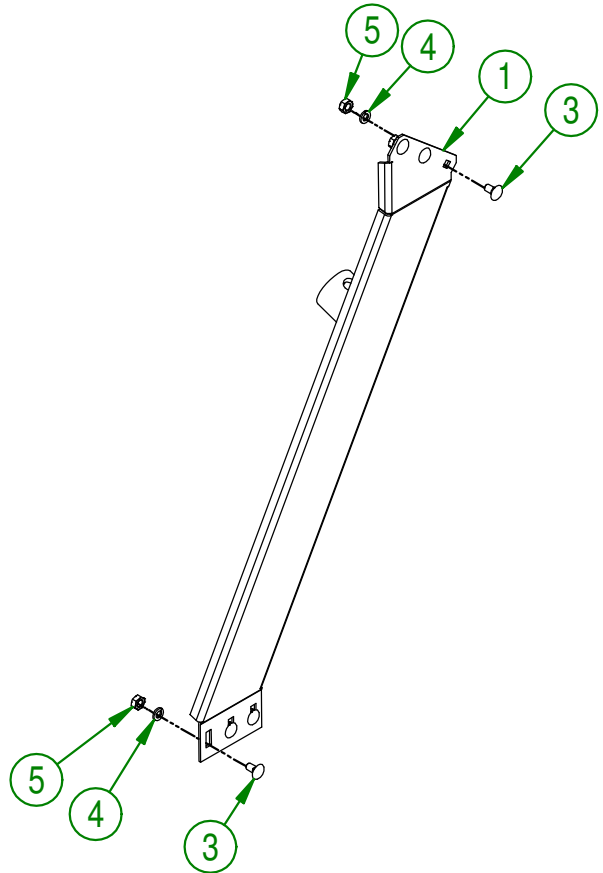
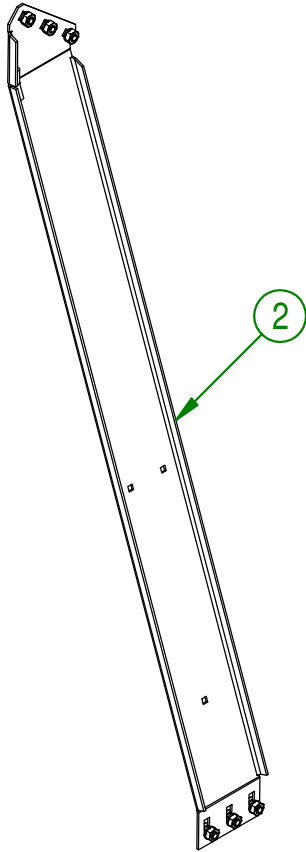

AGRIMETAL	
BOX SUPPORT	
CREATION : 2016-10-14	ASSEMBLY : 22-57-0170
REVISION : 2018-05-04	AUTHOR : S.B. Page 36 de 70

#	PART #	Qty	TITLE
1	22-57-0650	1	BACK DOOR "STICKER INCLUDED"
2	22-04-0005	1	LEFT DOOR LOCK
3	22-04-0007	1	RIGHT DOOR LOCK
4	NC01-02-0112	4	CARR. BOLT GR2 FLZ 3/8-16 X 1 3/4"
5	NC02-32-0012	4	LOCK WASHER ZINC 3/8"
6	NC02-07-0018	4	HEX. NUT ZINC 3/8-16
7	NC01-17-0255	2	HEX. BOLT GR2 ZINC 1/2-13 X 3"
8	01-01-0925	2	WASHER
9	NC01-17-0074	2	HEX. BOLT ZINC GR2 5/16-18 X 4 1/2"
10	NC02-22-0008	2	WASHER ZINC 5/16"
11	NC02-32-0011	2	LOCK WASHER ZINC 5/16"
12	NC02-07-0017	4	HEX. NUT 5/16-18

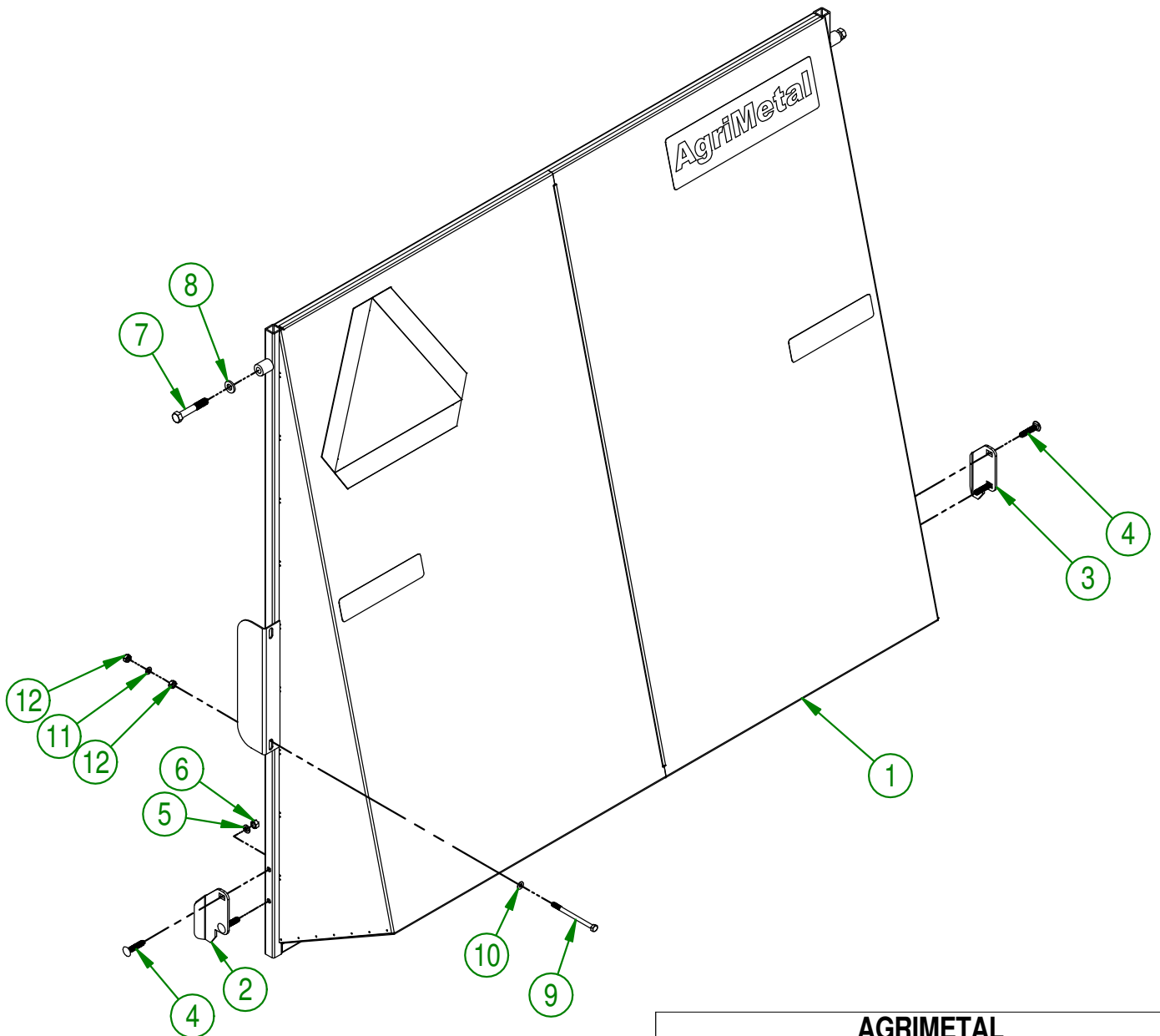

AGRIMETAL		
ASSEMBLY BACK DOOR		
CREATION : 2016-10-18	ASSEMBLY :	22-57-0185
REVISION : 2018-05-04	AUTHOR : S.B.	Page 37 de 70

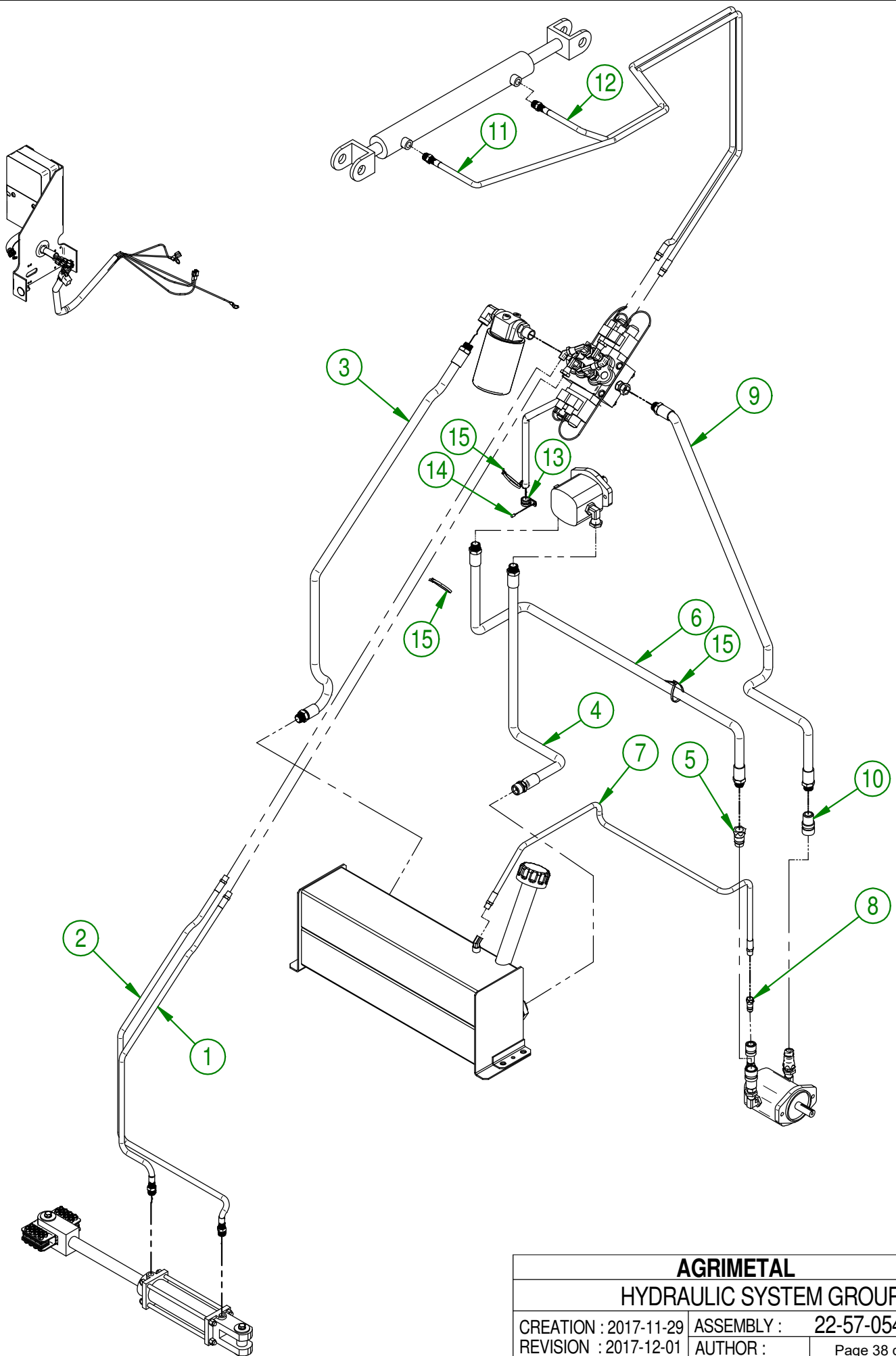

AGRIMETAL		
HYDRAULIC SYSTEM GROUP		
CREATION : 2017-11-29	ASSEMBLY :	22-57-0541
REVISION : 2017-12-01	AUTHOR :	Page 38 de 70

22-57-0541

#	PART #	Qty	TITLE
1	22-55-0170	1	HYDRAULIC HOSE 1/4 X 45"
2	22-55-0175	1	HYDRAULIC HOSE 1/4 X 35"
3	22-55-0150	1	HYDRAULIC HOSE 1/2 X 40"
4	22-55-0160	1	HYDRAULIC HOSE 1/2 X 24"
5	NC13-45-0014	1	QUICK COUPLER 1/2-14 NPTF
6	22-55-0154	1	HYDRAULIC HOSE 1/2 X 43 1/2"
7	22-55-0164	1	HYDRAULIC HOSE 1/4 X 44 1/2"
8	NC13-45-0112	1	QUICK COUPLER MALE 1/4-18 NPTF
9	22-55-0154	1	HYDRAULIC HOSE 1/2 X 43 1/2"
10	NC13-45-0047	1	QUICK COUPLER FEMALE 1/2-14 NPTF
11	22-55-0185	1	HYDRAULIC HOSE 1/4 X 85"
12	22-55-0180	1	HYDRAULIC HOSE 1/4 X 75"
13	NC13-25-0110	1	SNUG-FIT DAMPING LOOP CLAMP
14	NC01-78-0016	1	ALUMINIUM BLIND POP RIVET STEEL MANDREL 0.187 X 0.690
15	NC13-25-0019	3	BLACK TIE RAP

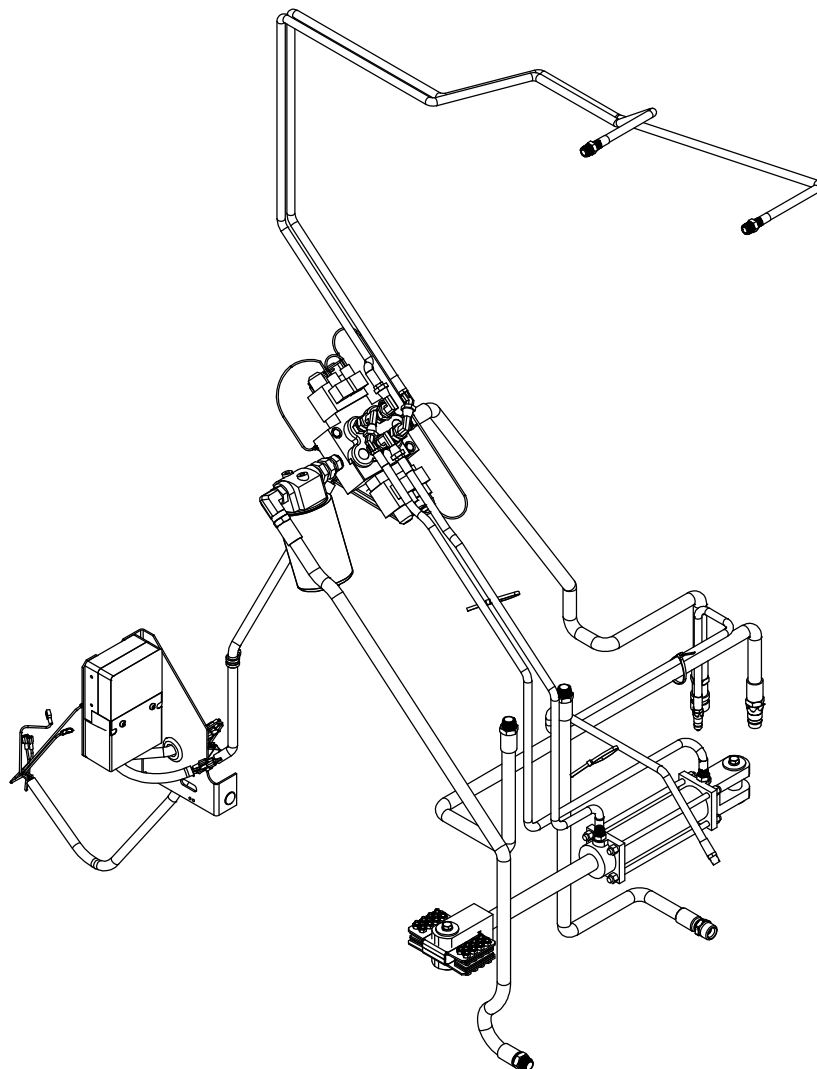

AGRIMETAL	
HYDRAULIC SYSTEM GROUP	
CREATION : 2017-11-29	ASSEMBLY : 22-57-0541
REVISION : 2017-12-01	AUTHOR : Page 39 de 70

#	PART #	Qty	TITLE
1	NCI3-45-0182	1	ASSEMBLY ELECTRIC VALVE DOUBLE SECTION
2	NCI3-45-0183	4	CO2 CONNECTOR
3	NCI3-45-0109	2	ELBOW 45° 1/4 NPT FEM. X 1/4 NPT MALE
4	NCI3-45-0108	4	ELBOW 90° 9/16-18 MALE SAE6 O RING
5	NCI3-45-0106	1	STRAIGHT REDUCER 3/4-16 MALE SAE8 O RING X 1/2 FEMALE
6	NCI3-45-0186	4	REDUCER STREIGHT 3/4-16 MALE SAE8 O RING X 9/16-18 FEMALE
7	NCI3-45-0110	1	STRAIGHT UNION 3/4-16 MALE SAE8 O RING X 3/4 FEMALE
8	NCI3-25-0386	1	WIRES TV4000
9	22-42-0220	1	WIRE PROTECTOR
10	NC01-17-0065	3	HEX. BOLT GR2. ZINC 5/16-18 X 2 1/4"
11	NC02-32-0011	3	LOCK WASHER ZINC 5/16"
12	NC02-07-0017	3	HEX. NUT 5/16-18

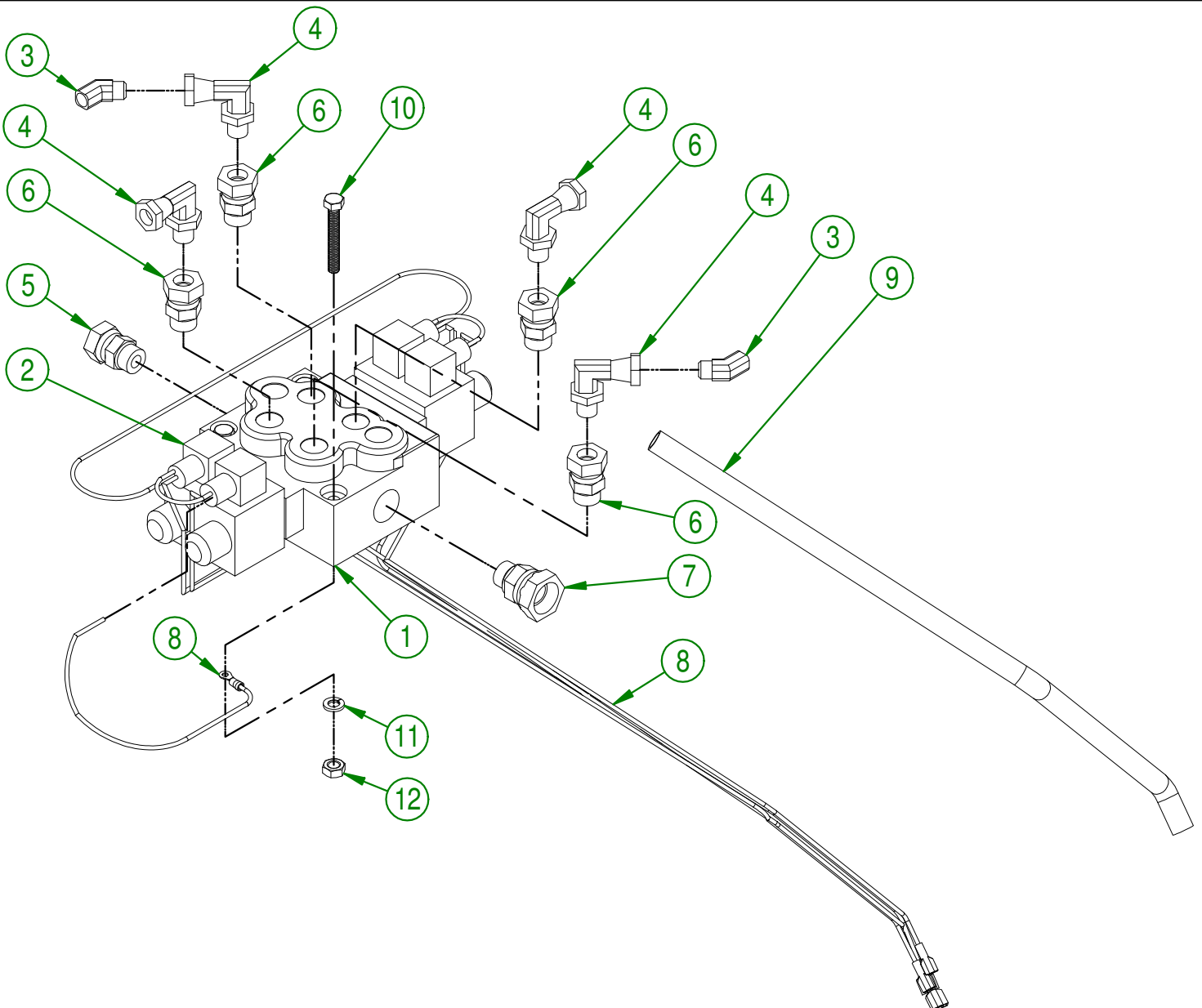

AGRIMETAL
HYDRAULIC VALVE GROUP

CREATION : 24/10/17
 REVISION : 01/02/18

ASSEMBLY : **22-57-0561**

AUTHOR : F.HÉLIE Page 40 de 70

#	PART #	Qty	TITLE
1	NC13-45-0030	1	MALE PIE COUPLING 3/4" NPT
2	NC13-45-0025	1	ELBOW 90° 1/2 FEMALE NPT X 1/2 MALE NPT
3	NC13-45-0032	1	STRAIGHT HOSE FITTING 1/2 FEM. NPT X 3/4 MALE NPT
4	NC13-45-0048	1	OIL FILTER
5	NC13-45-0049	1	HEAD FILTER

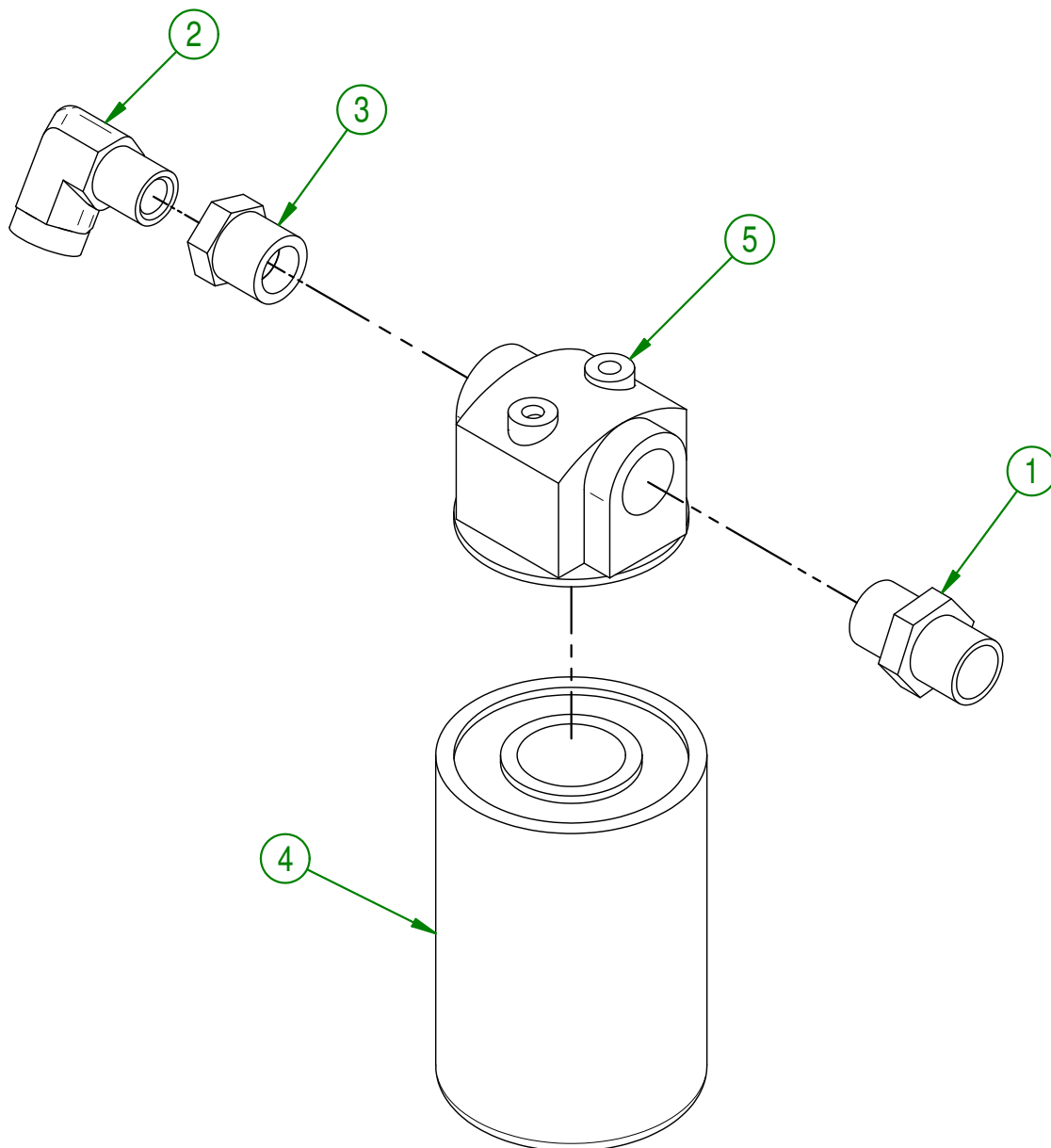

AGRIMETAL		
OIL FILTER		
CREATION : 18-10-2016	ASSEMBLY :	22-55-0095
REVISION : 18-01-2019	AUTHOR : S.B.	Page 41 de 70

#	PART #	Qty	TITLE
1	22-55-0200	1	CYLINDER 2 3/8" OD X 1 1/8" ROD X 7" TRAVEL
2	22-01-7630	2	CABLE CLAMP
3	22-22-5600	12	GAUGE PLATE
4	NC01-17-0008	16	HEX. BOLT GR2 ZINC 1/4-20 X 1 1/2"
5	NC01-96-0009	16	NYLON-INSERT LOCKNUT ZINC 1/4-20
6	22-13-1420	2	CYLINDER PIN
7	NC01-17-0114	4	HEX. BOLT GR2 ZINC 3/8-16 X 1"
8	NC02-32-0012	4	LOCK WASHER ZINC 3/8"
9	01-33-0010	4	WASHER
10	01-01-2485	1	FLAT WASHER 14 GA X 13/16"OD X 25/64" ID
11	NC13-45-0391	2	STRAIGHT UNION

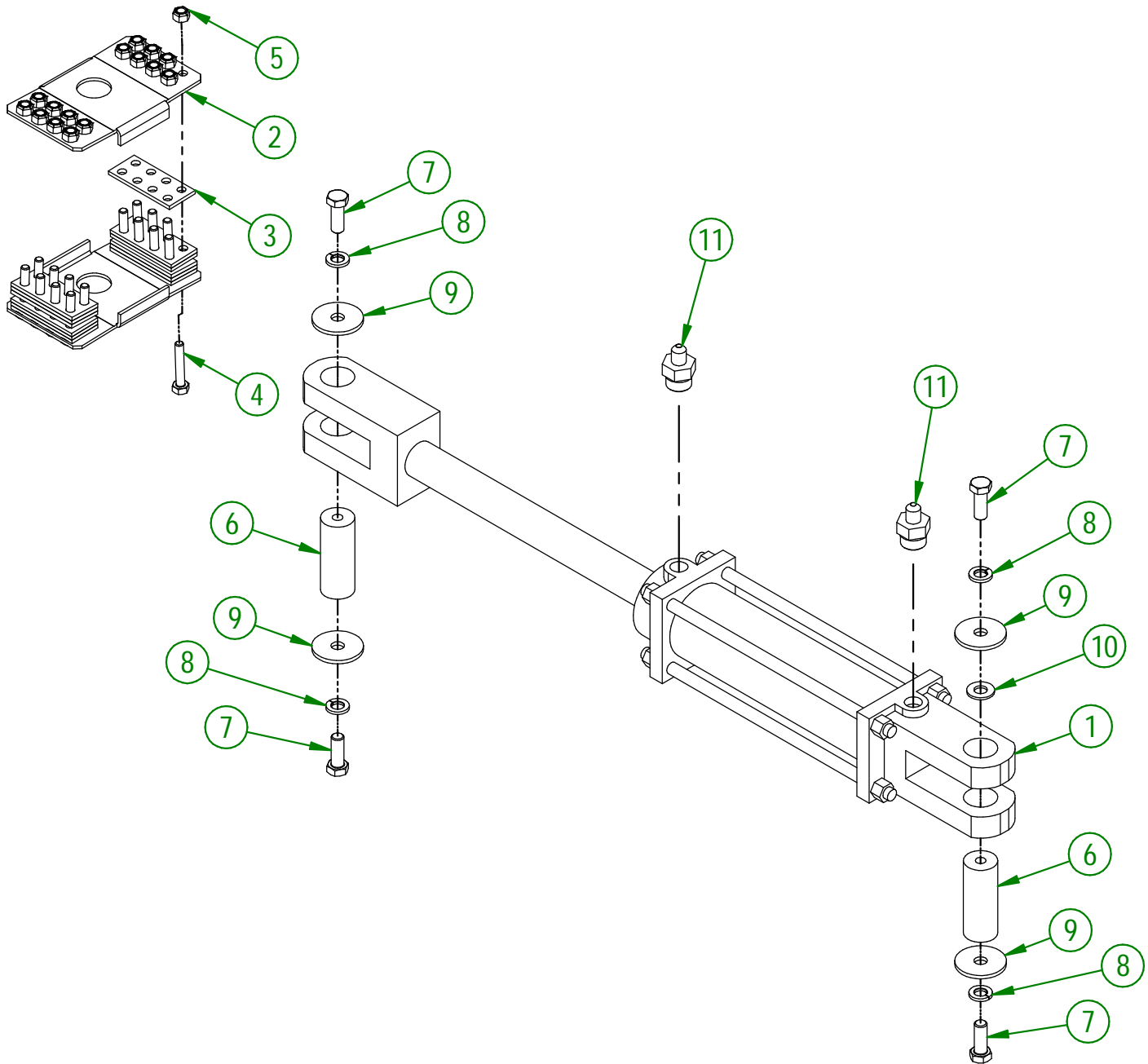

AGRIMETAL	
CYLINDER HEAD GROUP	
CREATION : 2016-10-18	ASSEMBLY : 22-57-0220
REVISION : 2023-04-24	AUTHOR : S.B.

#	PART #	Qty	TITLE
1	22-55-0100	1	CABLE PICK UP HEAD 3/16" X 45"
2	22-55-0105	1	CABLE PICK UP HEAD 3/16" X 73 1/2"
3	22-20-0255	2	CABLE LOCK PIN
4	NC01-63-0014	2	COTTER PIN Z 3/32" X 1 3/4" LG
5	12-42-0100	5	DEFLECTOR PULLEY
6	12-09-0100	5	BUSHING 3/4"
7	NC01-69-0463	5	SPRING PIN 1/4" X 1 3/4"
8	NC01-17-0252	5	HEX. BOLT GR2 ZINC 1/2-13 X 2 1/4"
9	NC02-32-0014	5	LOCK WASHER ZINC 1/2"
10	NC02-07-0020	5	HEX. NUT ZINC 1/2-13

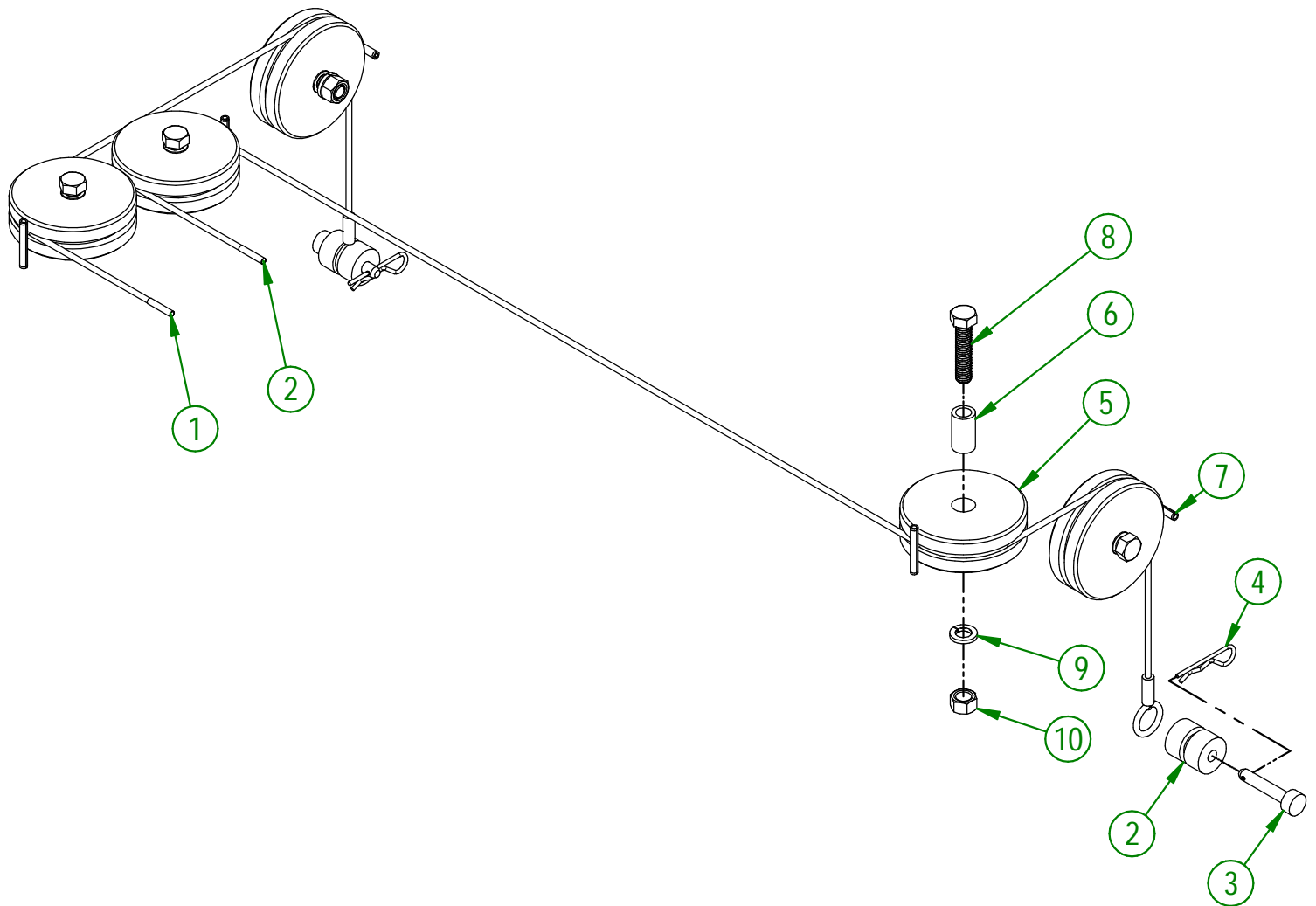

AGRIMETAL	
ASSEMBLY PICK UP HEAD HYDRAULIC LIFTING SYSTEM	
CREATION : 2016-10-19	ASSEMBLY : 22-57-0215
REVISION : 2023-02-09	AUTHOR : S.B.

#	PART #	Qty	TITLE
1	NC13-45-0016	1	FILLING CAP
2	NC13-45-0050	1	STRAINER TANK
3	NC13-45-0066	1	HEX. REDUCER 3/4" NPT FEM X 1 NPT MALE
4	NC01-76-0001	1	SIGHT GLASS 3/4 NPT
5	NC13-45-0109	1	ELBOW 45° 1/4 NPT FEM. X 1/4 NPT MALE
6	NC13-45-0015	1	HEX. CAP 1/2 NPTF MALE
7	22-57-0645	1	OIL TANK GROUP "STICKER INCLUDED"
8	22-13-0605	2	U BOLT
9	01-01-1660	4	WASHER SPACER
10	NC02-32-0014	4	LOCK WASHER ZINC 1/2"
11	NC02-07-0020	4	HEX. NUT ZINC 1/2-13

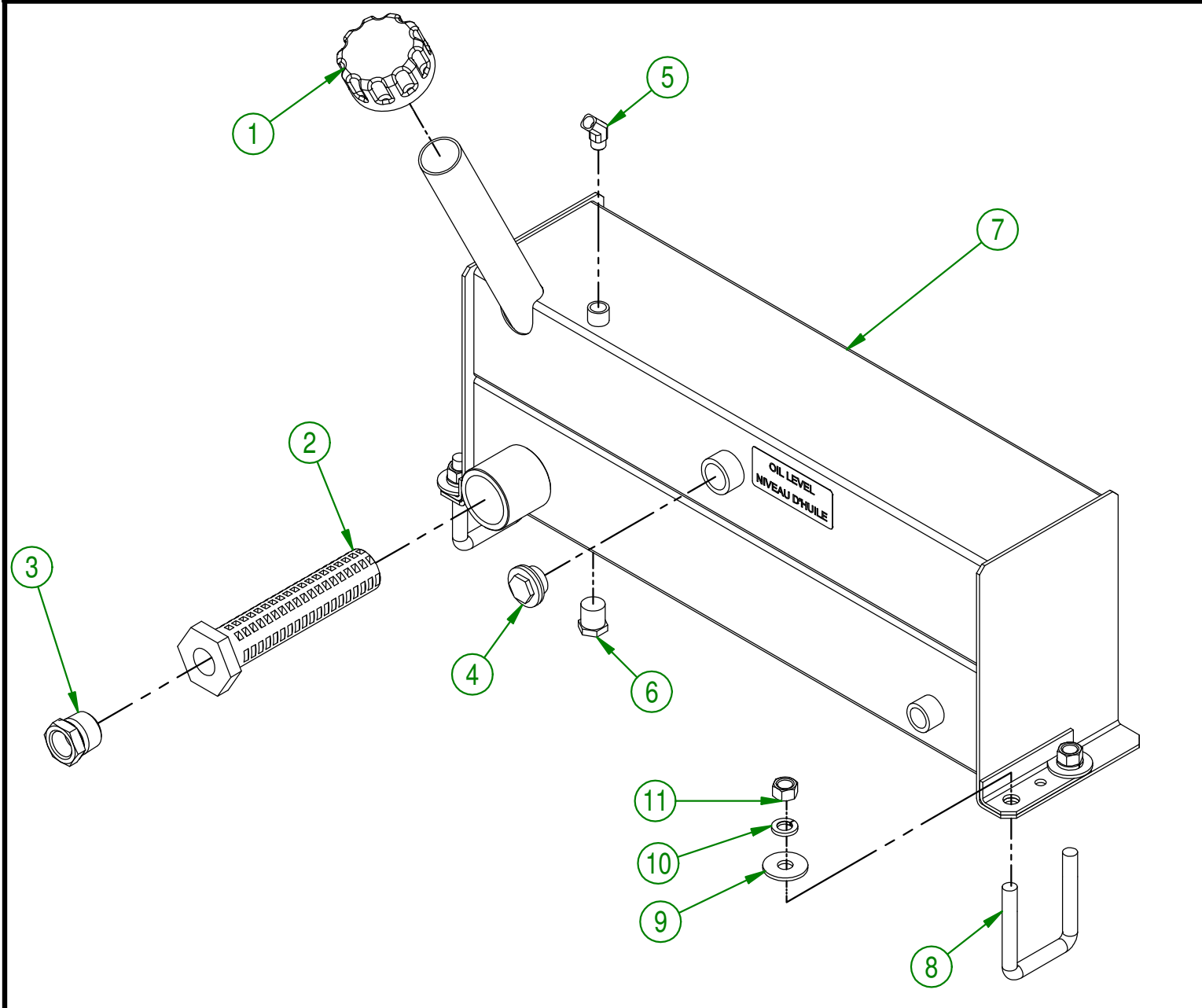

AGRIMETAL	
ASSEMBLY OIL TANK	
CREATION : 2016-10-14	ASSEMBLY : 22-57-0055
REVISION : 2018-05-04	AUTHOR : S.B. Page 44 de 70

#	PART #	Qty	TITLE
1	22-01-1550	1	ELECTRIC BOX SUPPORT
2	NC02-42-0086	4	SQUARE DRIVE SCREW #12 X 3/4"
3	NC13-15-0014	1	RUBBER WIRE WASHER
4	NC13-25-0390	1	WIRES TV4000
5	22-42-0225	1	WIRE PROTECTOR
6	22-42-0230	1	WIRE PROTECTOR
7	22-55-0610	1	ASSEMBLY ELECTRIC BOX
8	22-42-0235	1	WIRE PROTECTOR
9	NC01-04-0109	2	CARR. BOLT GR2 ZINC 3/8-16 X 1"
10	22-22-2210	2	ELECTRIC BOX SUPPORT WASHER
11	NC02-32-0012	2	LOCK WASHER ZINC 3/8"
12	NC02-07-0018	2	HEX. NUT ZINC 3/8-16

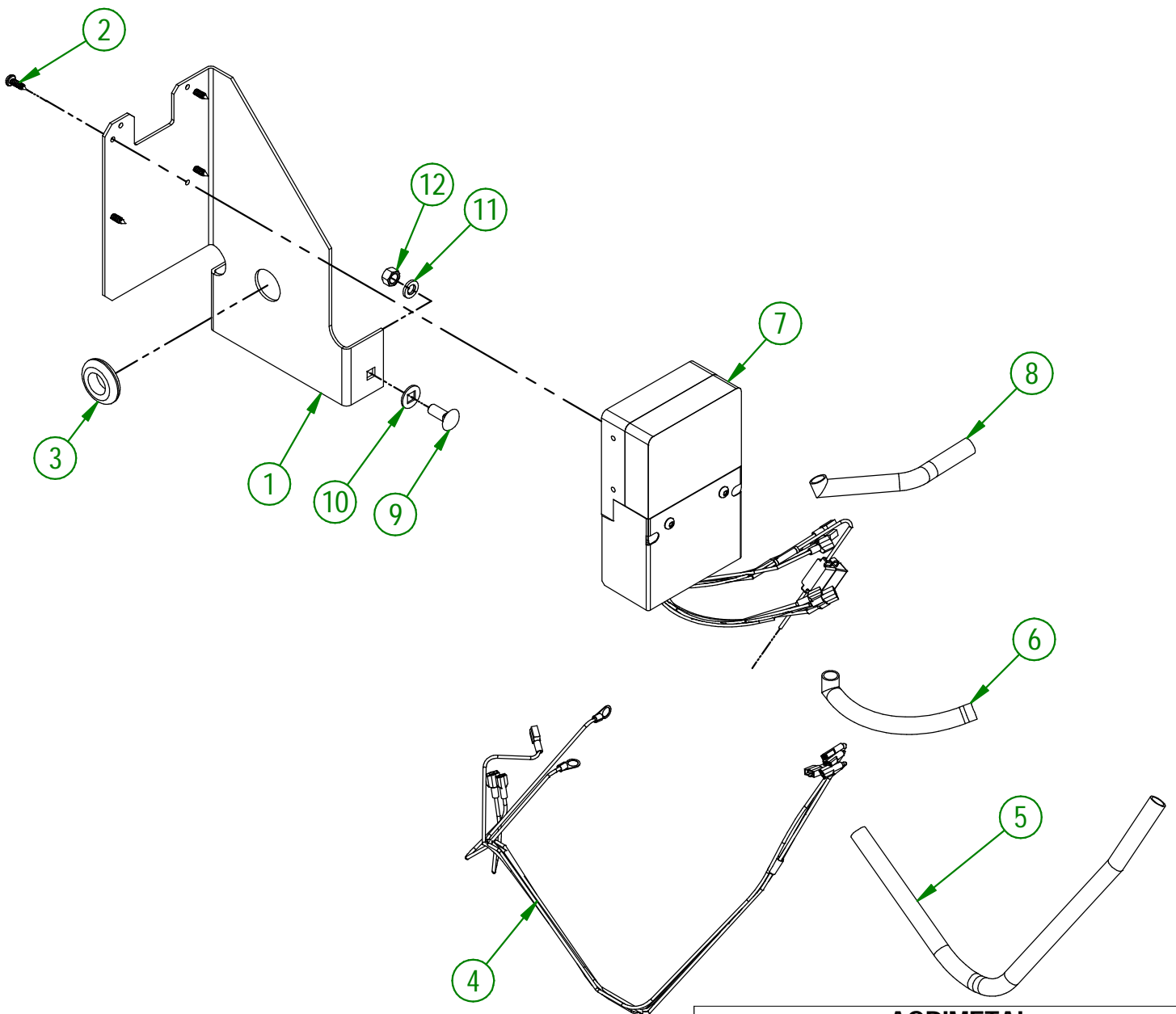

AGRIMETAL	
ASSEMBLY ELECTRIC CONTROL BOX	
CREATION : 2017-12-01	ASSEMBLY : 22-57-0268
REVISION : 2022-08-23	AUTHOR : Dessin2

#	PART #	Qty	TITLE
1	22-46-3750	1	GASKET
2	NC13-15-0034	2	RUBBER ABSORBER
3	NC02-32-0011	2	LOCK WASHER ZINC 5/16"
4	NC02-07-0017	2	HEX. NUT 5/16-18

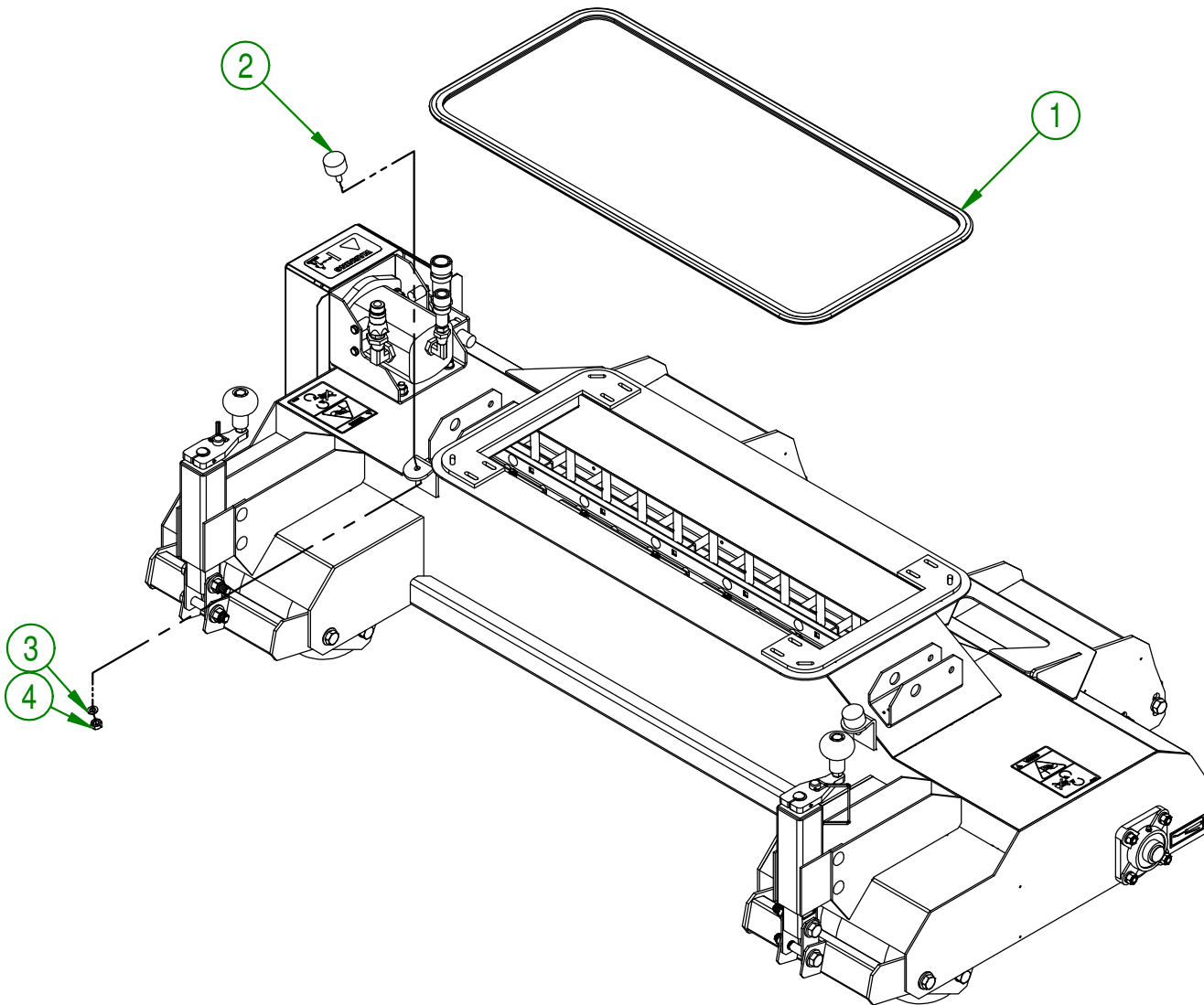
**AGRIMETAL**

PICK UP HEAD WITH ROTATIVE BRUSH (RUBBER FINGER)

CREATION : 2016-10-07

ASSEMBLY :

22-55-0046

REVISION : 2018-05-10

AUTHOR : S.B.

Page 46 de 70

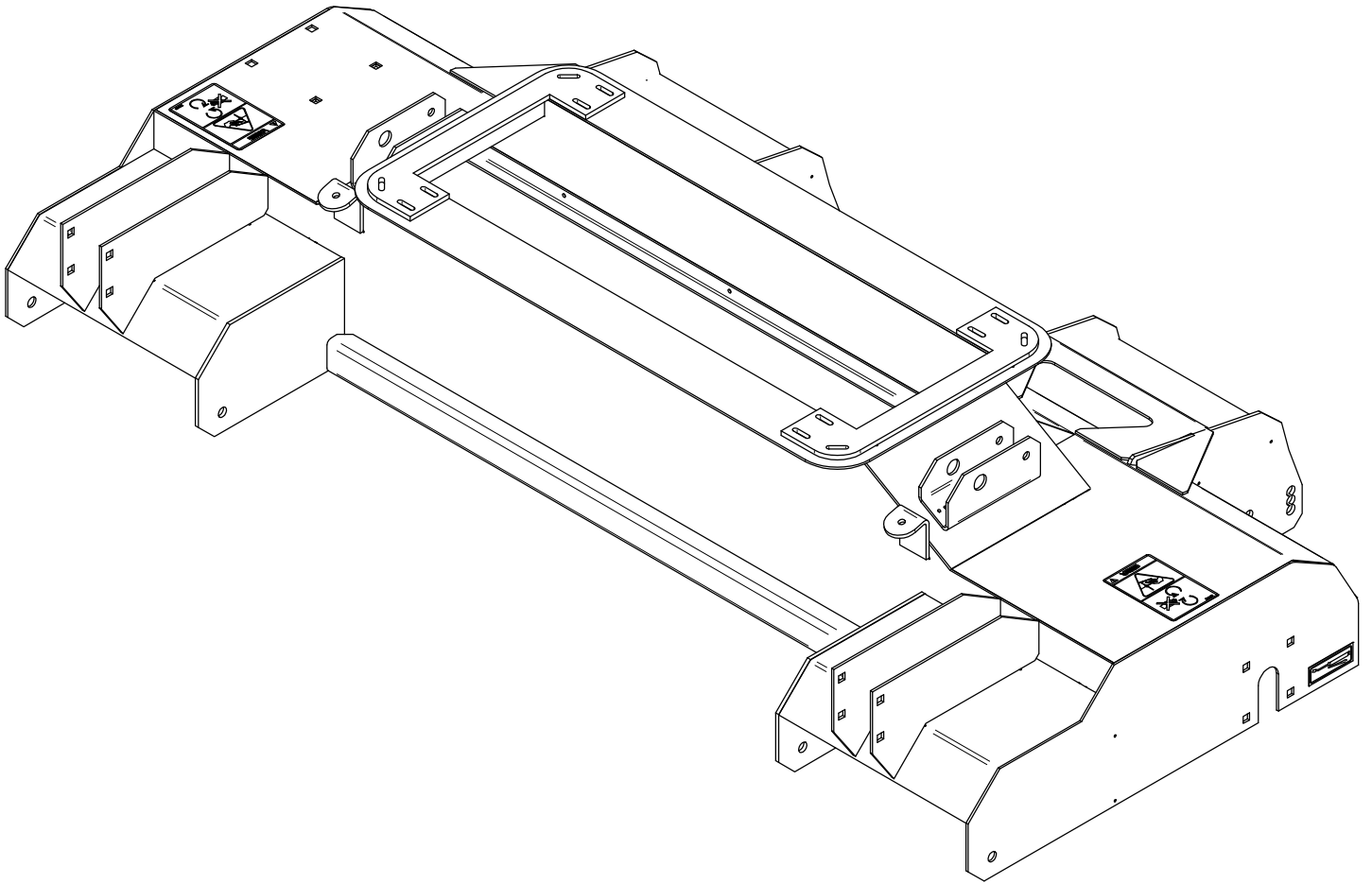

AGRIMETAL	
PICK UP HEAD "STICKER INCLUDED"	
CREATION : 14/11/17	ASSEMBLY : 22-57-0685
REVISION : 25/05/18	AUTHOR : F.HÉLIE Page 47 de 70

#	PART #	Qty	TITLE
1	22-50-0050	1	BRUSH ROTOR (FINGER) PTO & GAS
2	22-01-7540	20	RUBBER FINGER HOLDER
3	NC13-15-0347	80	RUBBER FINGER
4	NC01-04-0059	40	CARR. BOLT GR2 5/16-18 X 1 1/4
5	NC01-96-0010	40	NYLON NUT HEX. ZINC 5/16-18
6	22-03-0000	20	RUBBER FINGER STOP
7	22-50-0045	2	BEARING COVER
8	NC01-04-0110	8	CARR. BOLT GR2 ZINC 3/8-16 X 1 1/4"
9	NC02-32-0012	8	LOCK WASHER ZINC 3/8"
10	NC02-07-0018	8	HEX. NUT ZINC 3/8-16
11	22-55-0120	2	PILLOW BLOCK BEARING UCF 205-16 Ø 1"
12	01-41-0910	1	KEY
13	03-39-0155	1	PULLEY 2MA40 X 1" KW 1/4" 2SET SREW 5/16-18
14	NC01-17-0058	2	HEX. BOLT GR2 ZINC 5/16-18 X 3/4"

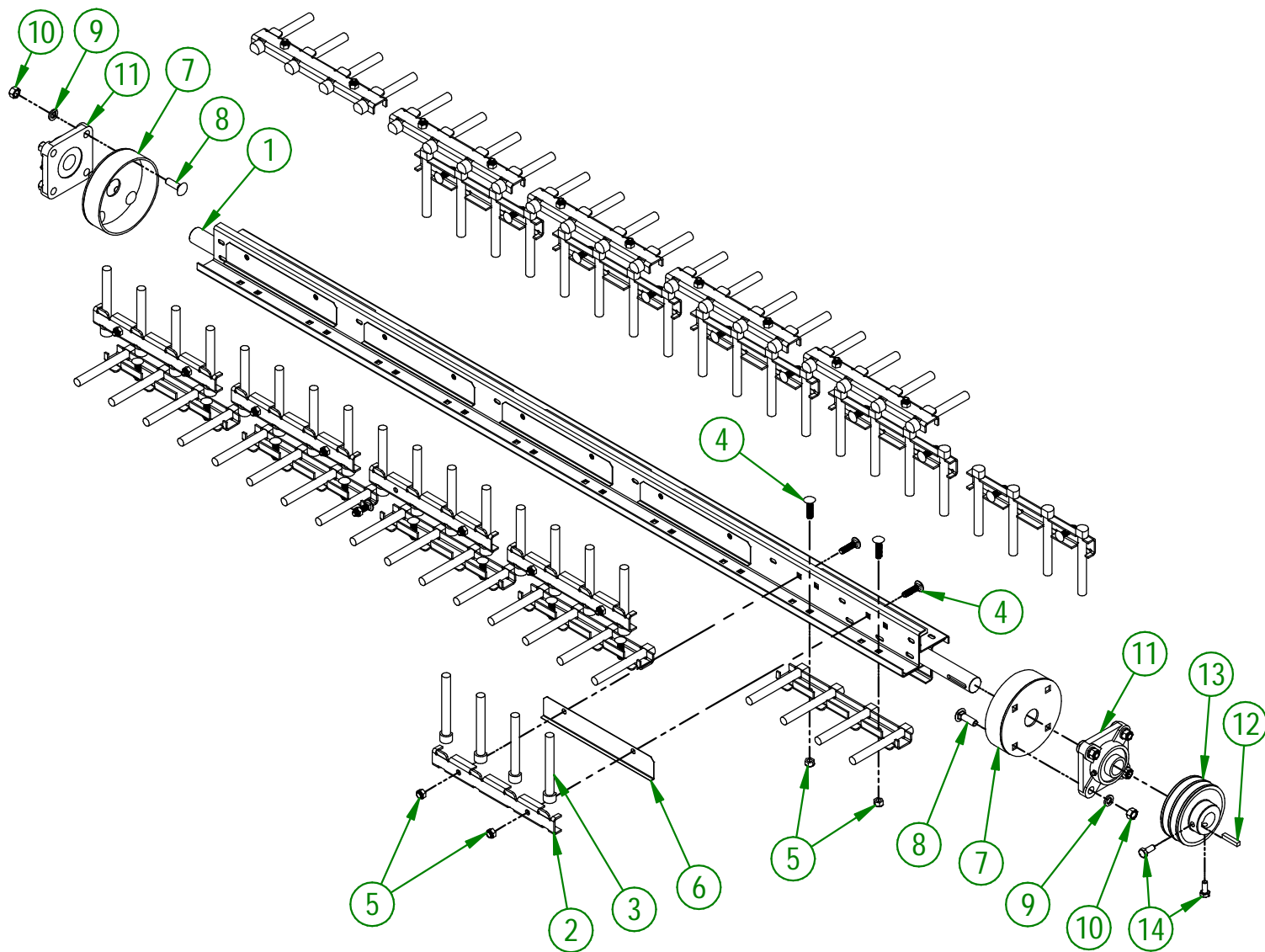

AGRIMETAL	
ROTARY BRUSH	
CREATION : 2016-10-07	ASSEMBLY : 22-57-0040
REVISION : 2022-10-24	AUTHOR : Dessin2

#	PART #	Qty	TITLE
1	22-46-3750	1	GASKET
2	NC13-15-0034	2	RUBBER ABSORBER
3	NC02-32-0011	2	LOCK WASHER ZINC 5/16"
4	NC02-07-0017	2	HEX. NUT 5/16-18

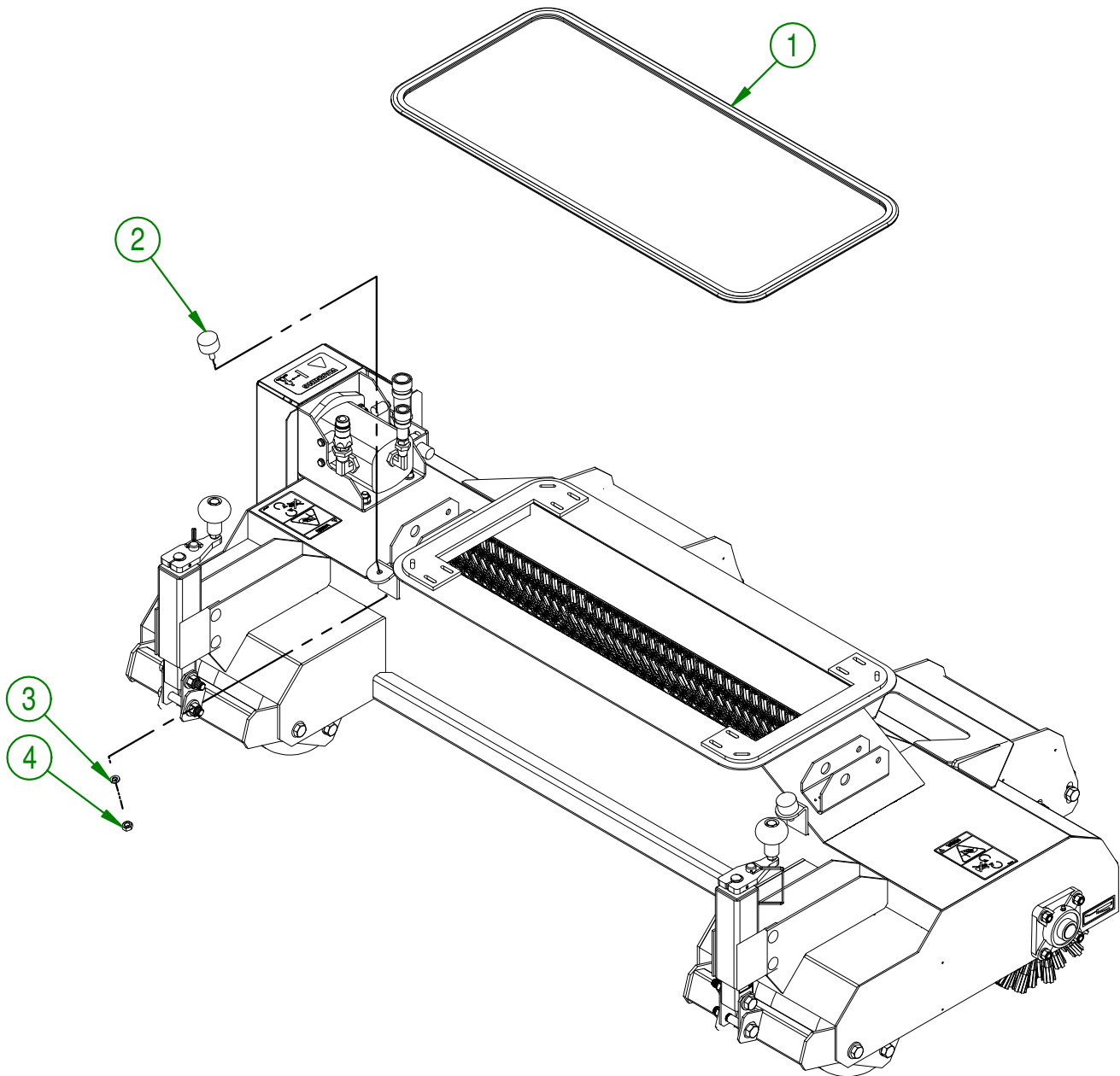
**AGRIMETAL****NYLON BRISTLE ROTARY BRUSH HEAD ASS'Y**

CREATION : 15/11/17
 REVISION : 25/05/18

ASSEMBLY : **22-55-0053**

AUTHOR : F.HÉLIE Page 49 de 70

#	PART #	Qty	TITLE
1	NC17-02-0291	1	NYLON BRISTLE BRUSH ASSY
2	01-41-0910	1	KEY
3	03-39-0155	1	PULLEY 2MA40 X 1" KW 1/4" 2SET SREW 5/16-18
4	22-01-7675	2	BEARING PROTECTOR (NYLON BRUSH)
5	22-55-0120	2	PILLOW BLOCK BEARING UCF 205-16 Ø 1"
6	NC01-04-0110	8	CARR. BOLT GR2 ZINC 3/8-16 X 1 1/4"
7	NC02-07-0018	8	HEX. NUT ZINC 3/8-16
8	NC02-32-0012	8	LOCK WASHER ZINC 3/8"
9	NC01-17-0058	2	HEX. BOLT GR2 ZINC 5/16-18 X 3/4"

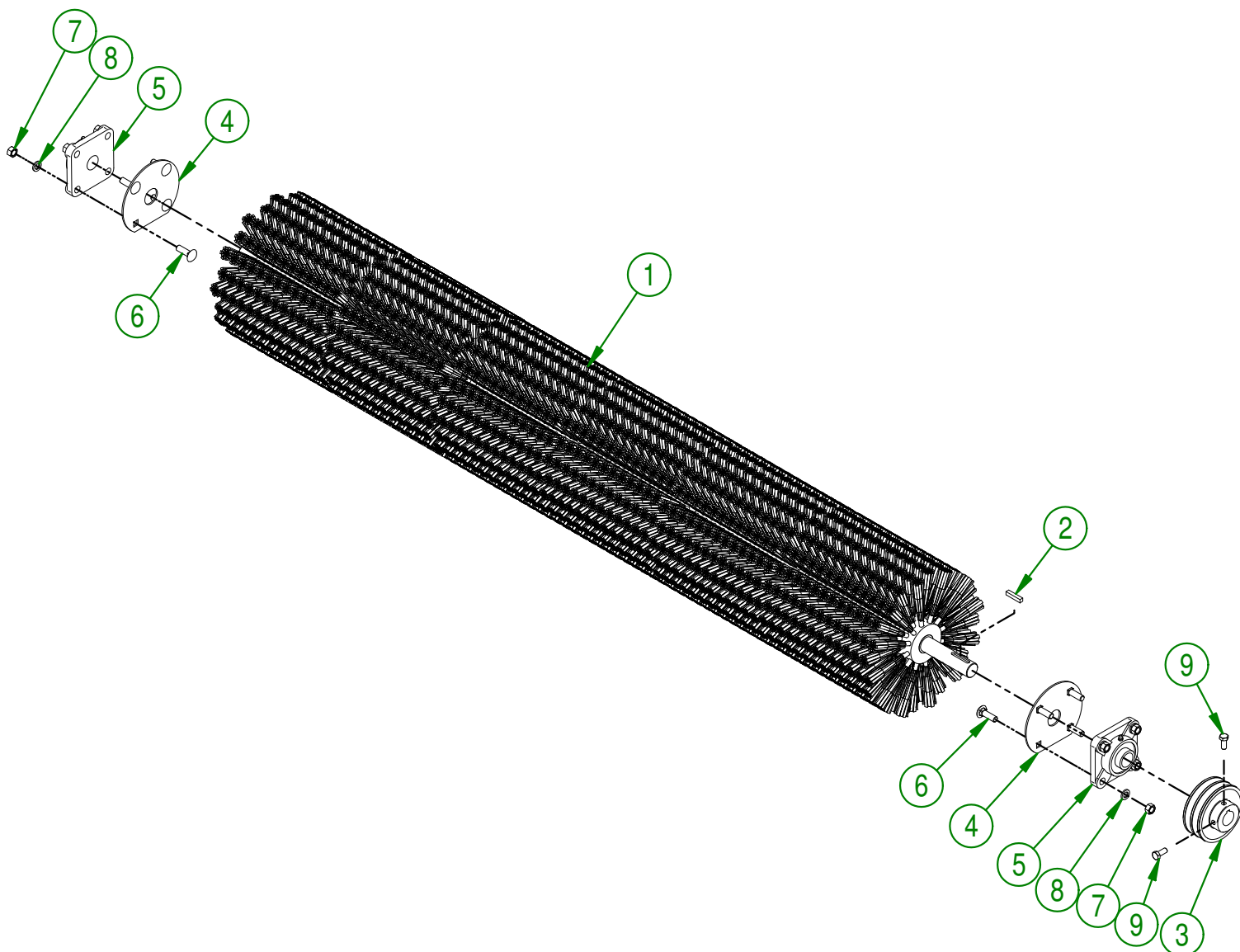

AGRIMETAL	
ASSEMBLY NYLON BRUSH	
CREATION : 20/09/17	ASSEMBLY : 22-57-0044
REVISION : 16/01/19	AUTHOR : F.HÉLIE Page 50 de 70

#	PART #	Qty	TITLE
1	22-46-3750	1	GASKET
2	NC13-15-0034	2	RUBBER ABSORBER
3	NC02-32-0011	2	LOCK WASHER ZINC 5/16"
4	NC02-07-0017	2	HEX. NUT 5/16-18

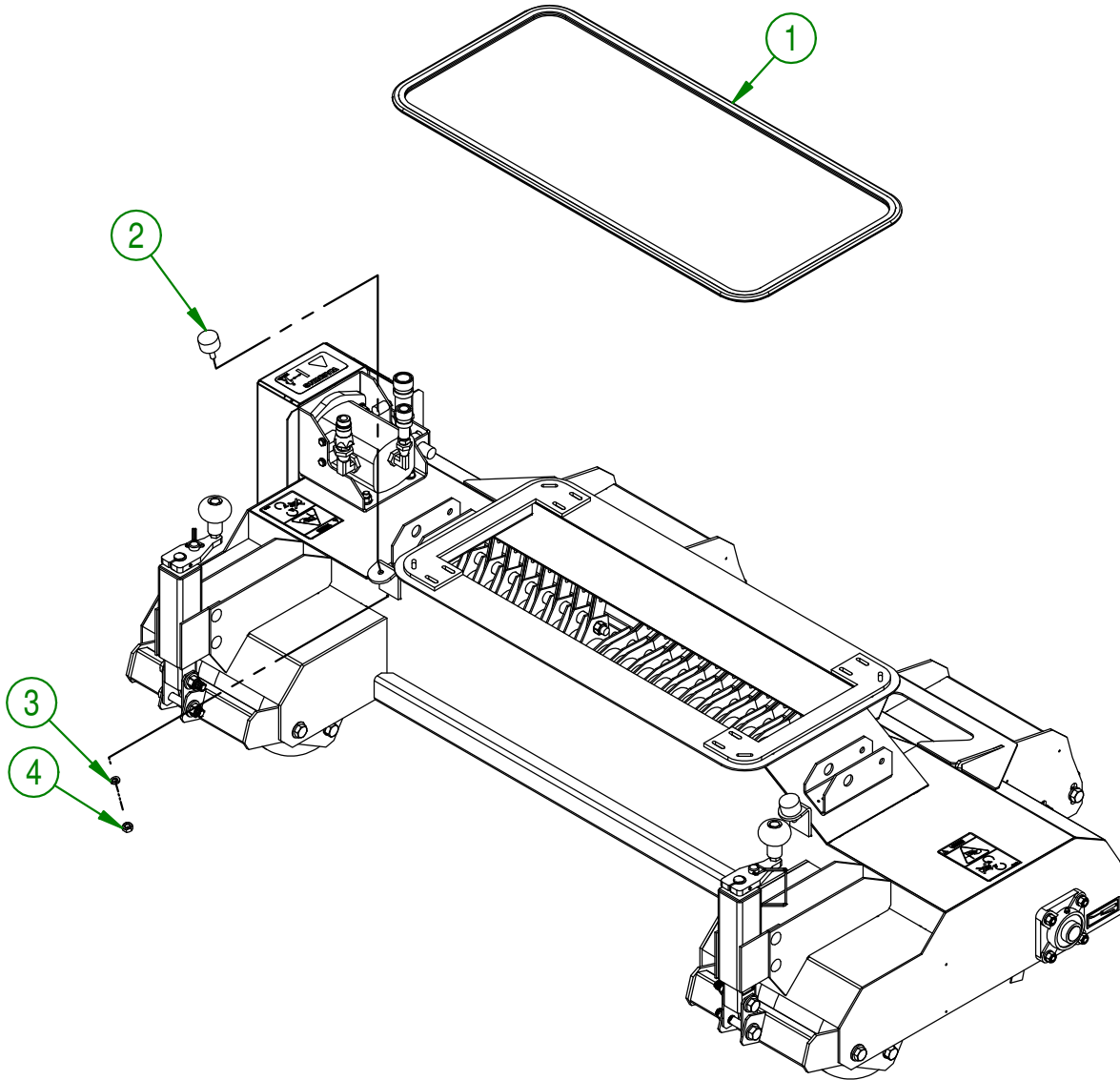
**AGRIMETAL****DETHATCHING HEAD WITH KNIVES SYSTEM ASS'Y**

CREATION : 18/09/17
 REVISION : 10/05/18

ASSEMBLY : **22-55-0051**

AUTHOR : F.HÉLIE | Page 51 de 70

#	PART #	Qty	TITLE
1	01-41-0910	1	KEY
2	03-39-0155	1	PULLEY 2MA40 X 1" KW 1/4" 2SET SREW 5/16-18
3	22-50-1020	2	BEARING PROTECTOR (HAMMER ROTOR)
4	22-55-0120	2	PILLOW BLOCK BEARING UCF 205-16 Ø 1"
5	NC01-04-0110	8	CARR. BOLT GR2 ZINC 3/8-16 X 1 1/4"
6	NC02-07-0018	8	HEX. NUT ZINC 3/8-16
7	NC02-32-0012	8	LOCK WASHER ZINC 3/8"
8	NC01-17-0058	2	HEX. BOLT GR2 ZINC 5/16-18 X 3/4"

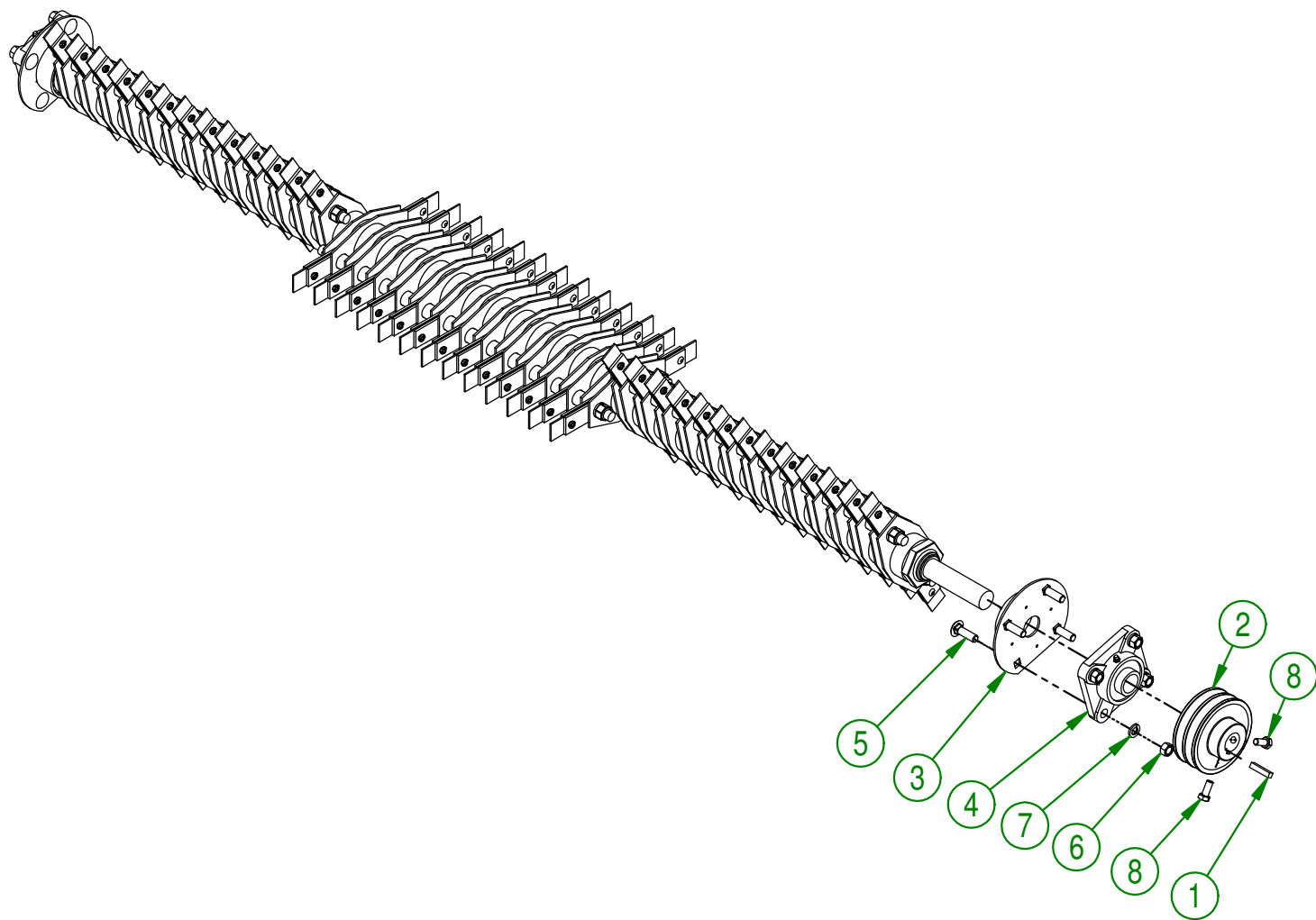

AGRIMETAL	
ASSEMBLY ROTARY BRUSH (HAMMER)	
CREATION : 18/09/17	ASSEMBLY : 22-57-0043
REVISION : 16/01/19	AUTHOR : F.HÉLIE Page 52 de 70

#	PART #	Qty	TITLE
1	22-25-2403	1	ROTOR SHAFT
2	22-09-0805	2	HAMMER SUPPORT SHIM (TIP)
3	22-01-7691	78	HAMMER SUPPORT
4	22-20-0401	6	HAMMER PIVOT
5	22-09-0810	39	HAMMER SUPPORT SHIM
6	22-09-0800	38	HAMMER SUPPORT SHIM
7	NC01-96-0014	12	NYLON-INSERT LOCKNUT ZINC 1/2-13
8	NC01-98-0021	2	HEX. BLOC NUT 1 1/4-18
9	22-55-0355	78	ROTOR HAMMER ASS'Y.

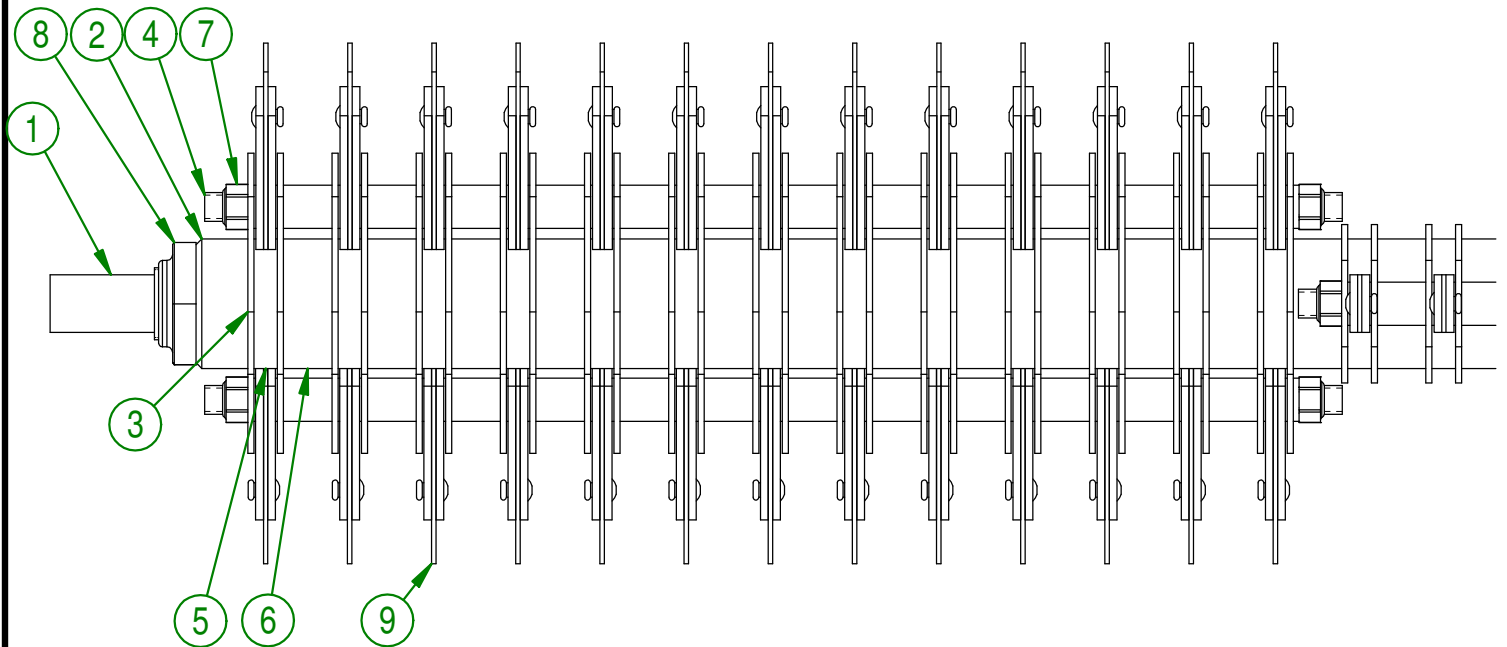
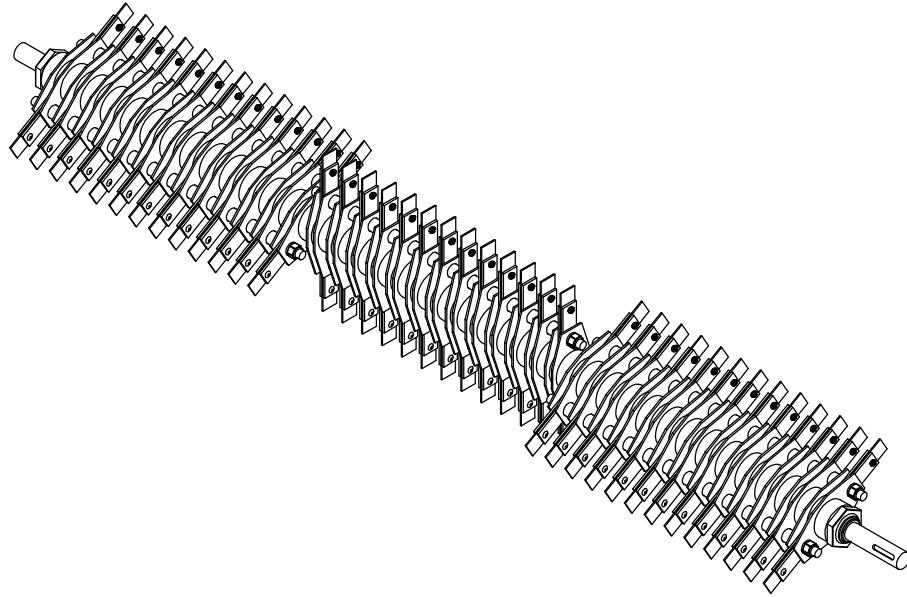

AGRIMETAL	
ROTARY BRUSH (HAMMER) ASS'Y	
CREATION : 20/03/17	ASSEMBLY : 22-55-0019
REVISION : 15/11/17	AUTHOR : F.HÉLIE Page 53 de 70

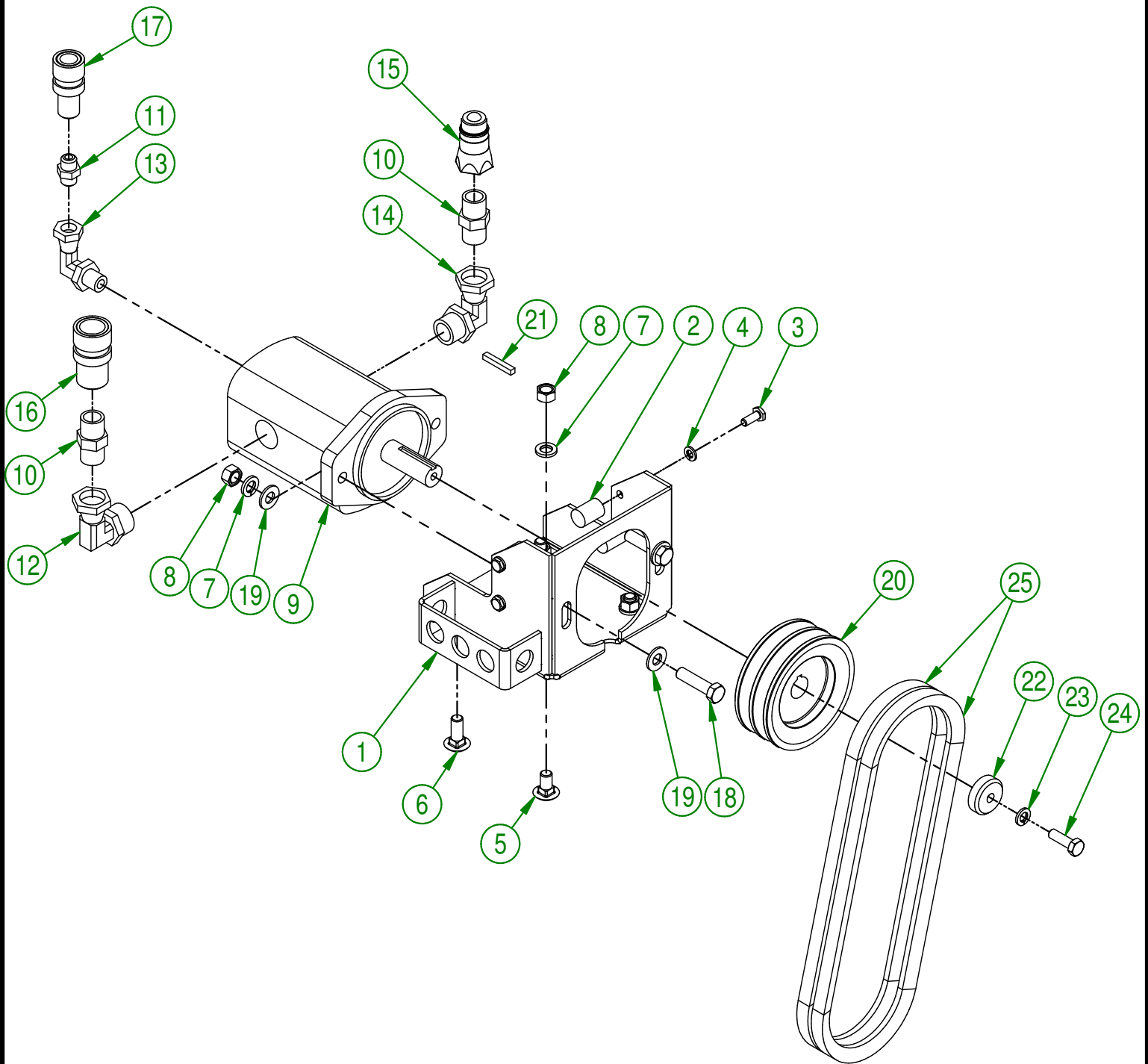

USE THESE PIECES ONLY IF YOUR SERIAL
NUMBER IS AFFECTED:

#40420 AND UNDER

AGRIMETAL	
HYDRAULIC MOTOR MOUNT	
CREATION : 07-10-2016	ASSEMBLY : 22-57-0030
REVISION : 27-05-2021	AUTHOR : S.B.

#	PART #	Qty	TITLE
1	22-50-0010	1	HYDRAULIC MOTOR SUPPORT
2	22-21-0030	4	HYDRAULIC MOTOR STOPPER
3	NC01-29-0003	4	HEX. BOLT GR5 ZINC 1/4-28 X 5/8"
4	NC02-32-0010	4	LOCK WASHER ZINC 1/4"
5	NC01-04-0107	2	CARR. BOLT GR2 ZINC 3/8-16 X 3/4"
6	NC01-04-0109	2	CARR. BOLT GR2 ZINC 3/8-16 X 1"
7	NC02-32-0012	6	LOCK WASHER ZINC 3/8"
8	NC02-07-0018	6	HEX. NUT ZINC 3/8-16
9	NC14-45-0022	1	HYDRAULIC MOTOR
10	NC13-45-0029	2	HEX. NIPPLE 1/2 MALE NPT X 1/2 MALE NPT
11	NC13-45-0114	1	HEX. NIPPLE 1/4 MALE NPT X 1/4 MALE NPT
12	NC13-45-0113	1	ELBOW 90° 1 1/16-12 MALE SAE12 O RING X 1/2 FEM. TOUR. NPT
13	NC13-45-0108	1	ELBOW 90° 9/16-18 MALE SAE6 O RING
14	NC13-45-0028	1	ELBOW 90° 7/8-14 MALE SAE O RING X 1/2 FEM NPT
15	NC13-45-0014	1	QUICK COUPLER 1/2-14 NPTF
16	NC13-45-0047	1	QUICK COUPLER FEMALE 1/2-14 NPTF
17	NC13-45-0111	1	QUICK COUPLEUR FEMALE X FEMALE NPTF 1/4-18
18	NC01-17-0116	2	HEX. BOLT GR2 ZINC 3/8-16 X 1 1/2"
19	01-01-2485	4	FLAT WASHER 14 GA X 13/16"OD X 25/64" ID
20	NC14-62-0162	1	2MA40 PULLEY X Ø3/4" KW 3/16" 2SS
21	01-41-0905	1	SQUARE KEY 3/16" X 1 1/4"TL
22	22-21-0020	1	PULLEY RETAINING CAP
23	NC02-32-0011	1	LOCK WASHER ZINC 5/16"
24	NC01-17-0060	1	HEX. BOLT GR2 ZINC 5/16-18 X 1"
25	NC14-25-0254	2	V BELT 1/2 A-27

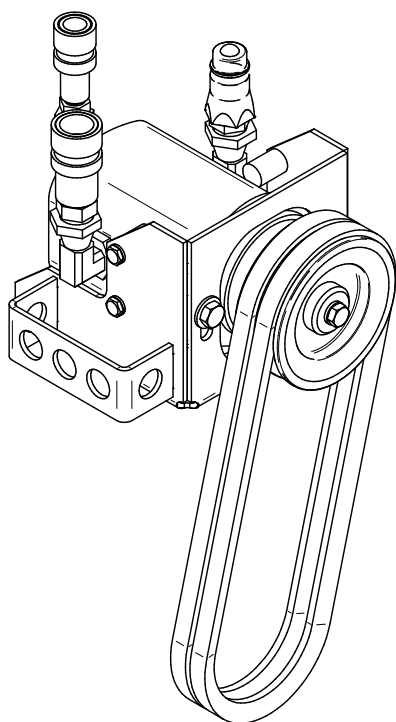

AGRIMETAL	
HYDRAULIC MOTOR MOUNT	
CREATION : 07-10-2016	ASSEMBLY : 22-57-0030
REVISION : 27-05-2021	AUTHOR : S.B.

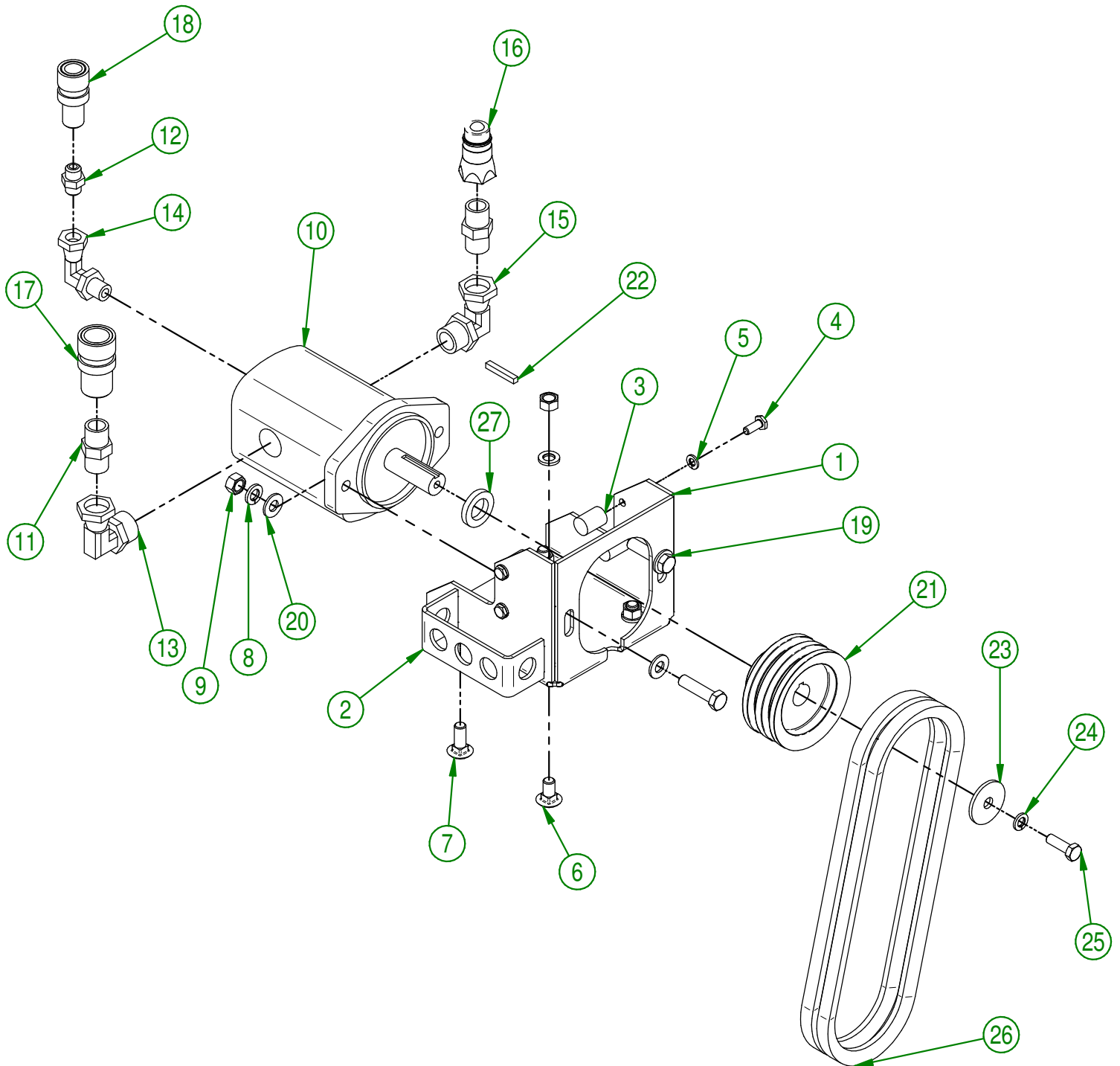

USE THESE PIECES ONLY IF YOUR SERIAL
NUMBER IS AFFECTED:

#40421 AND ABOVE

AGRIMETAL	
HYDRAULIC MOTOR SUPPORT GROUP	
CREATION : 25/05/21	ASSEMBLY : 22-57-0031
REVISION : 09/06/21	AUTHOR : G.HUBERDEAU

22-57-0031

#	PART #	Qty	TITLE
1	22-01-1035	1	HYDRAULIC MOTOR SUPPORT
2	22-01-1030	1	BELT TENSIONER BRACKET
3	22-21-0030	4	HYDRAULIC MOTOR STOPPER
4	NC01-29-0003	4	HEX. BOLT GR5 ZINC 1/4-28 X 5/8"
5	NC02-32-0010	4	LOCK WASHER ZINC 1/4"
6	NC01-04-0107	2	CARR. BOLT GR2 ZINC 3/8-16 X 3/4"
7	NC01-04-0109	2	CARR. BOLT GR2 ZINC 3/8-16 X 1"
8	NC02-32-0012	6	LOCK WASHER ZINC 3/8"
9	NC02-07-0018	6	HEX. NUT ZINC 3/8-16
10	NC14-45-0022	1	HYDRAULIC MOTOR
11	NC13-45-0029	2	HEX. NIPPLE 1/2 MALE NPT X 1/2 MALE NPT
12	NC13-45-0114	1	HEX. NIPPLE 1/4 MALE NPT X 1/4 MALE NPT
13	NC13-45-0113	1	ELBOW 90° 1/16-12 MALE SAE12 O RING X 1/2 FEM. TOUR. NPT
14	NC13-45-0108	1	ELBOW 90° 9/16-18 MALE SAE6 O RING
15	NC13-45-0028	1	ELBOW 90° 7/8-14 MALE SAE O RING X 1/2 FEM NPT
16	NC13-45-0014	1	QUICK COUPLER 1/2-14 NPTF
17	NC13-45-0047	1	QUICK COUPLER FEMALE 1/2-14 NPTF
18	NC13-45-0111	1	QUICK COUPLEUR FEMALE X FEMALE NPTF 1/4-18
19	NC01-17-0116	2	HEX. BOLT GR2 ZINC 3/8-16 X 1 1/2"
20	01-01-2485	4	FLAT WASHER 14 GA X 13/16"OD X 25/64" ID
21	NC14-62-0232	1	2MA35 PULLEY X Ø3/4" KW 3/16" 2SS
22	01-41-0905	1	SQUARE KEY 3/16" X 1 1/4"TL
23	01-33-0010	1	WASHER
24	NC02-32-0011	1	LOCK WASHER ZINC 5/16"
25	NC01-17-0060	1	HEX. BOLT GR2 ZINC 5/16-18 X 1"
26	NC14-25-5371	2	V BELT 1/2 COGGED RAW EDGE AX-26
27	22-09-0000	1	

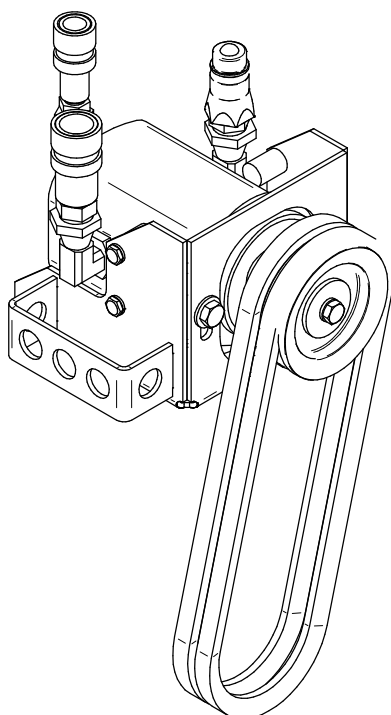
**AGRIMETAL**

HYDRAULIC MOTOR SUPPORT GROUP

CREATION : 25/05/21

REVISION : 09/06/21

ASSEMBLY : **22-57-0031**

AUTHOR : G.HUBERDEAU

#	PART #	Qty	TITLE
1	22-50-0030	1	BELT TIGHTENER PIVOT
2	22-41-0080	2	TENSION BELT BUSHING
3	NC02-44-0102	2	SOCKET HEAD CAP SCREW 5/16-18 X 5/16"
4	22-21-0005	1	TENSION PULLEY
5	NC14-75-0068	1	BALL BEARING 99502H
6	NC01-64-0142	1	SNAP RING HOLE I 3/8"
7	22-21-0025	1	IDLER PULLEY BUSHING
8	NC01-17-0117	1	HEX. BOLT GR2 ZINC 3/8-16 X I 3/4"
9	01-01-2485	1	FLAT WASHER
10	NC02-32-0012	2	LOCK WASHER ZINC 3/8"
11	NC02-07-0018	3	HEX. NUT ZINC 3/8-16
12	NC13-85-0008	1	GALVANISED SPRING
13	NC01-17-0116	1	HEX. BOLT GR2 ZINC 3/8-16 X I 1/2"

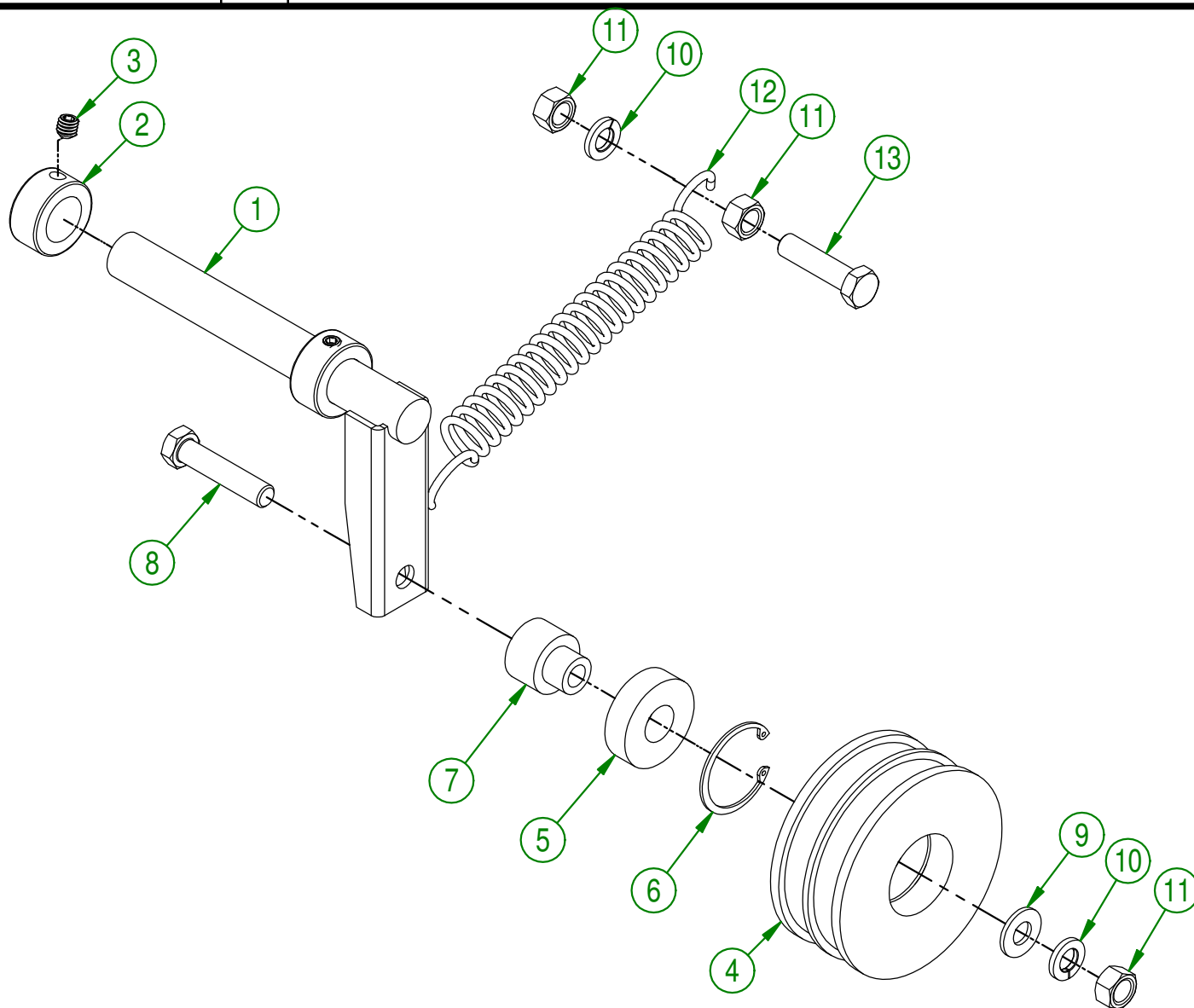

AGRIMETAL	
BELT TENSIONNEUR	
CREATION : 2016-10-07	ASSEMBLY : 22-57-0045
REVISION : 2018-05-04	AUTHOR : S.B. Page 56 de 70

#	PART #	Qty	TITLE
1	22-57-0680	1	BELT GUARD (STICKER INCLUDED)
2	01-01-2485	3	FLAT WASHER
3	NC02-32-0012	3	LOCK WASHER ZINC 3/8"
4	NC02-07-0018	3	HEX. NUT ZINC 3/8-16

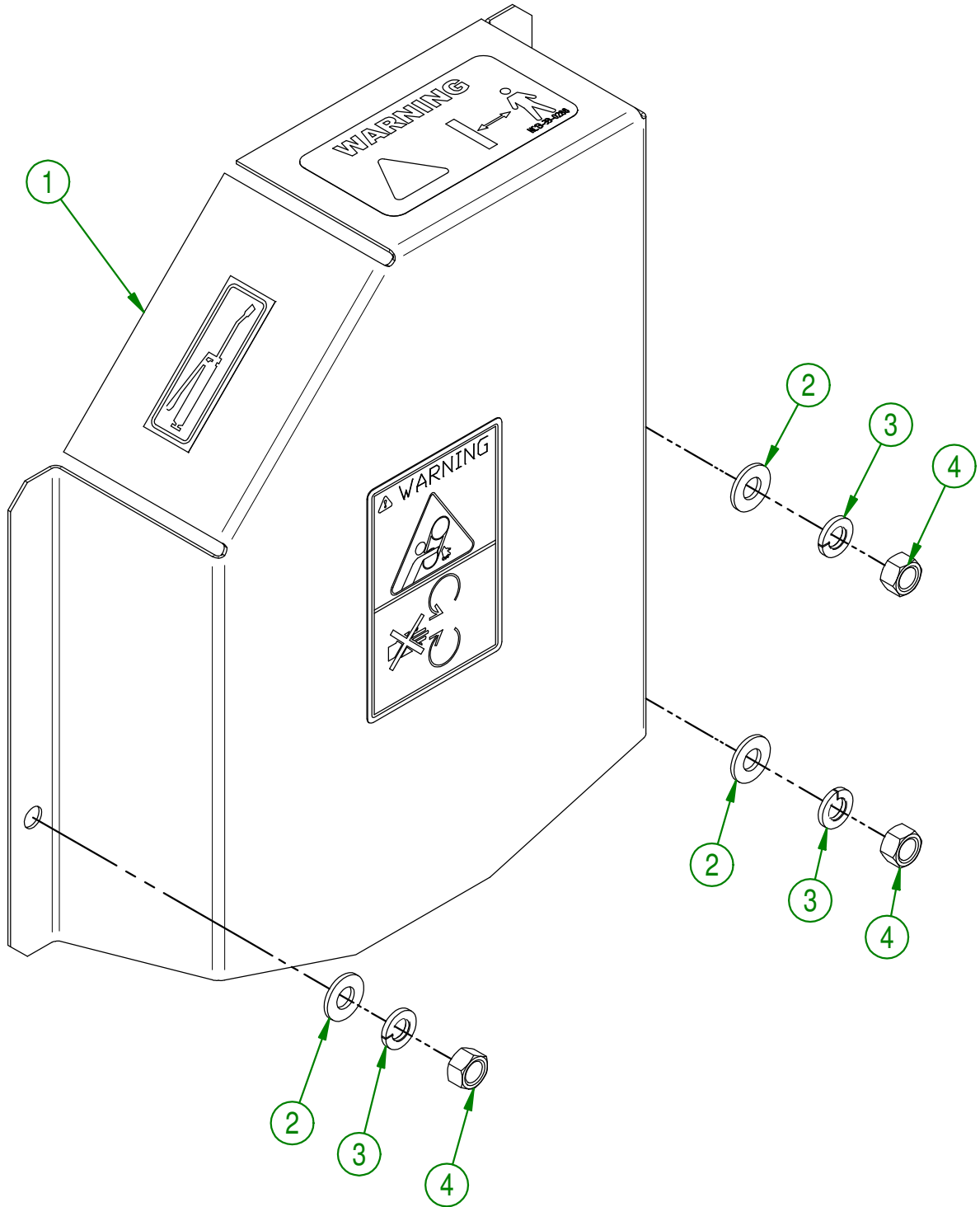

AGRIMETAL	
BELT GUARD GROUP	
CREATION : 2016-10-19	ASSEMBLY : 22-57-0037
REVISION : 2018-05-04	AUTHOR : S.B. Page 57 de 70

28-57-0017

#	PART #	Qty	TITLE
1	28-57-0015	1	ADJUSTABLE JACK GROUP (LEFT)
2	28-57-0016	1	ADJUSTABLE JACK GROUP (RIGHT)
3	28-01-1035	4	UNION BRACKET
4	NC02-25-0011	8	WASHER SAE ZINC 17/32 ID
5	NC01-17-0253	2	HEX. BOLT GR2 ZINC 1/2-13 X 2 1/2"
6	NC01-17-0255	2	HEX. BOLT GR2 ZINC 1/2-13 X 3"
7	NC01-93-0014	4	LOCK NUT ZINC 1/2-13
8	NC01-69-1300	2	LOCKING PIN 1/4" DIA. X 2 1/2" GRIP X 1 5/8" H AC ZINC

28-57-0015 / 28-57-0016

#	PART #	Qty	TITLE
8	28-50-0070	1	MANUAL ACTUATOR MOBILE SQUARE TUBE
9	28-50-0075	1	MANUAL ACTUATOR FIXED TUBE
10	28-42-0105	2	TRUST WASHER
11	01-33-0035	2	FLAT WASHER Ø 1 1/4" X Ø 49/64" X 10 GA.
12	NC01-69-0419	2	SPRING TIGHTENER PIN ZINC 3/16 XI"
13	28-04-0600	1	ROTATING PLATE (MANUAL ACTUATOR)
14	NC17-46-0018	1	HANDLE KNOB
15	NC01-17-0122	1	HEX. BOLT GR2 ZINC 3/8-16 X 3"
16	01-01-2485	1	FLAT WASHER 14 GA X 13/16"OD X 25/64" ID
17	NC01-96-0011	1	NYLON NUT 3/8-16
18	NC01-69-0429	1	SPRING PIN ZINC 3/16" X 1 3/4"
19	28-31-1150	1	MANUAL ACTUATOR ACME ROD
20	NC01-04-0107	4	CARR. BOLT GR2 ZINC 3/8-16 X 3/4"
21	NC02-32-0012	4	LOCK WASHER ZINC 3/8"
22	NC02-07-0018	4	HEX. NUT ZINC 3/8-16

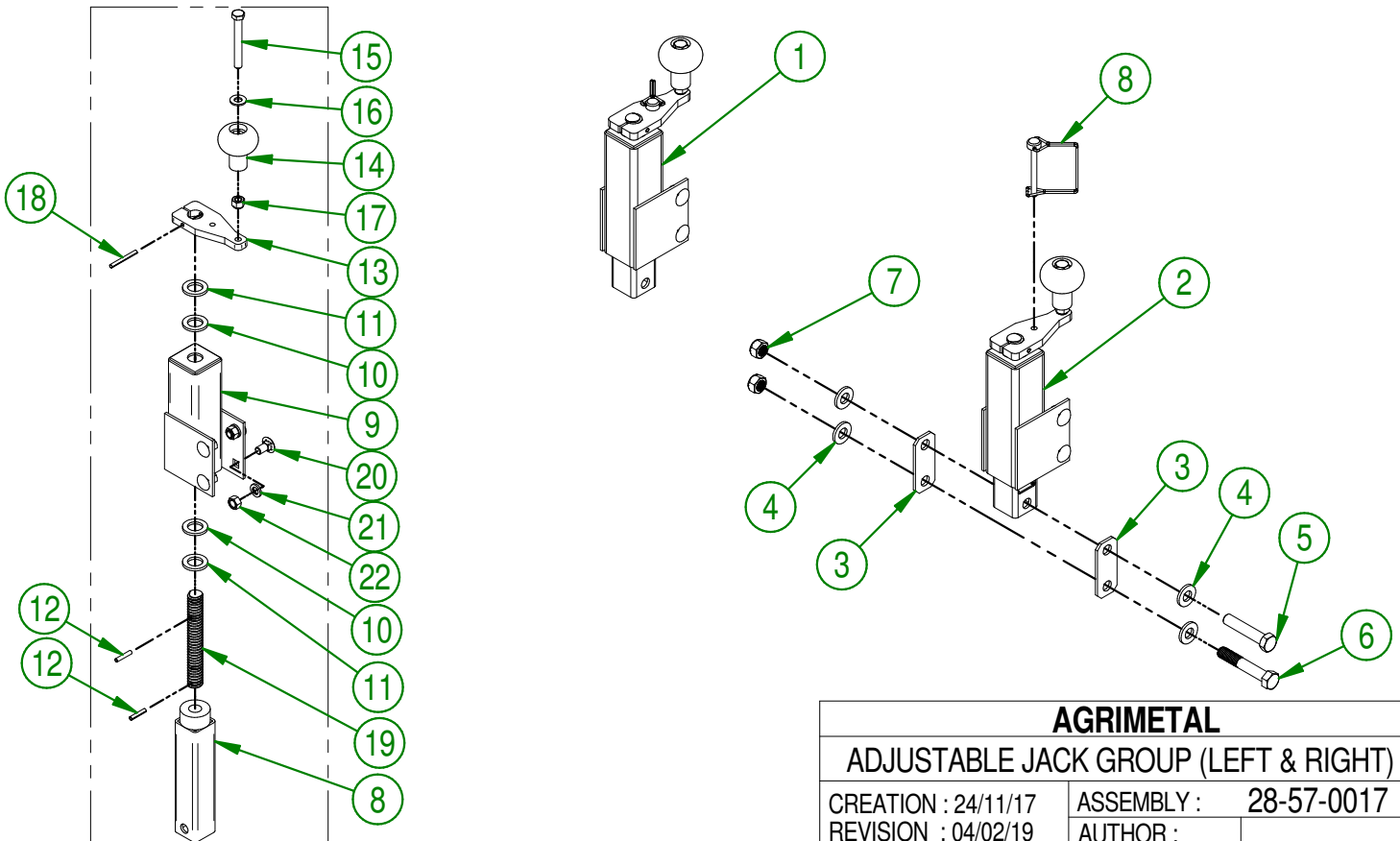

AGRIMETAL	
ADJUSTABLE JACK GROUP (LEFT & RIGHT)	
CREATION : 24/11/17	ASSEMBLY : 28-57-0017
REVISION : 04/02/19	AUTHOR :

22-57-0195

#	PART #	Qty	TITLE
1	22-50-0015	1	TRACTION ARM (PTO & GAS)
2	22-13-1600	2	ATTACHMENT ARM PIN
3	NC01-63-0026	2	COTTER PIN ZC 5/32" X 3"

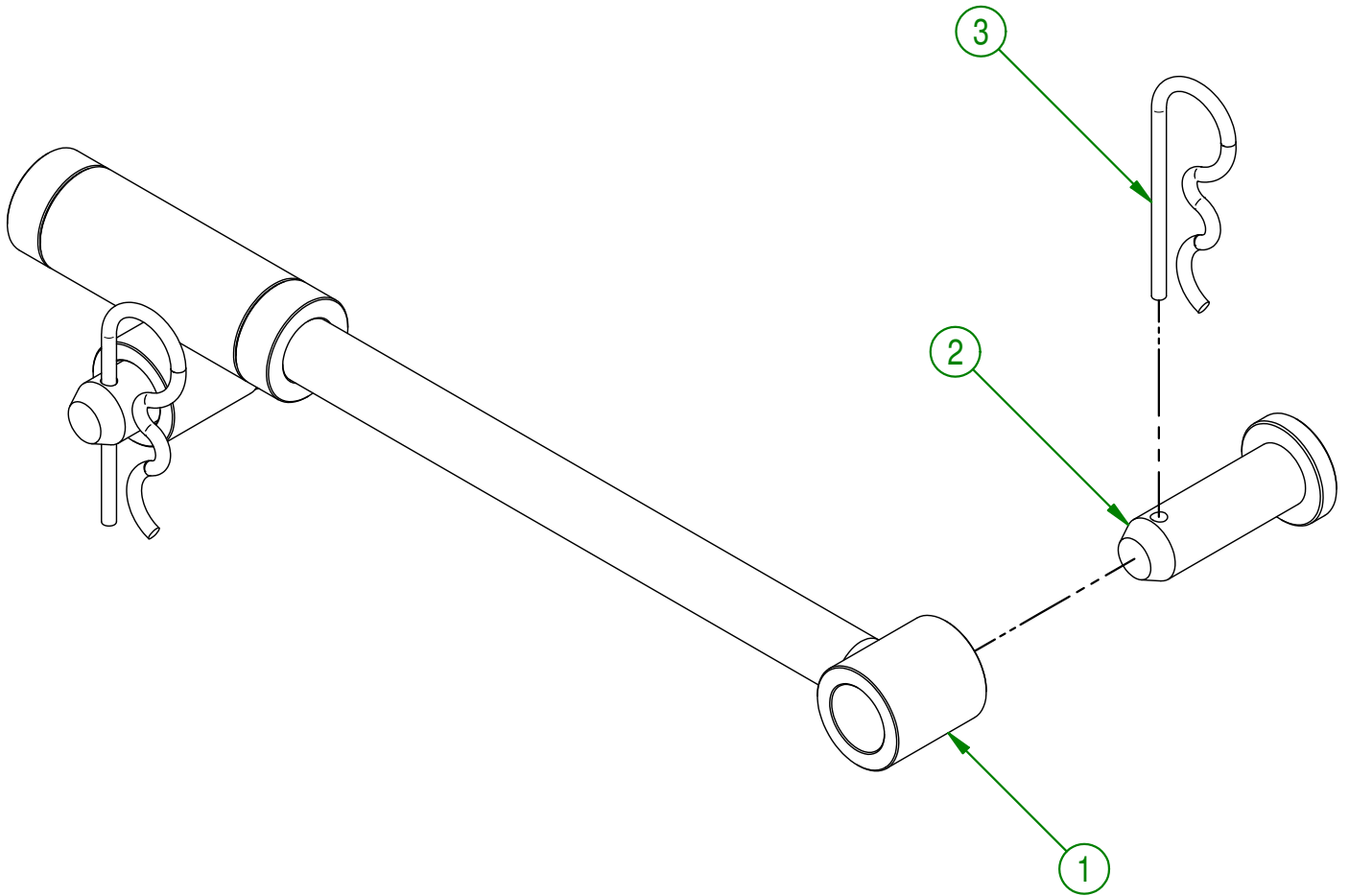

AGRIMETAL	
PICK UP HEAD ARM	
CREATION : 17/11/17	ASSEMBLY : 22-57-0195
REVISION : 14/11/18	AUTHOR : F.HÉLIE Page 59 de 70

22-57-0270

#	PART #	Qty	TITLE
1	22-55-0360	1	ROLLER Ø 6"
2	22-13-1430	1	REAR ROLLER SHAFT
3	28-42-0120	2	SPACER
4	NC02-32-0014	4	LOCK WASHER ZINC 1/2"
5	NC01-17-0247	4	HEX. BOLT GR2 ZINC 1/2-13 X 1"
6	22-50-0190	1	ROLLER SCRAPER

22-55-0360

#	PART #	Qty	TITLE
7	NC14-75-0070	2	6205-2RS BEARING
8	22-46-0000	1	ROLLER

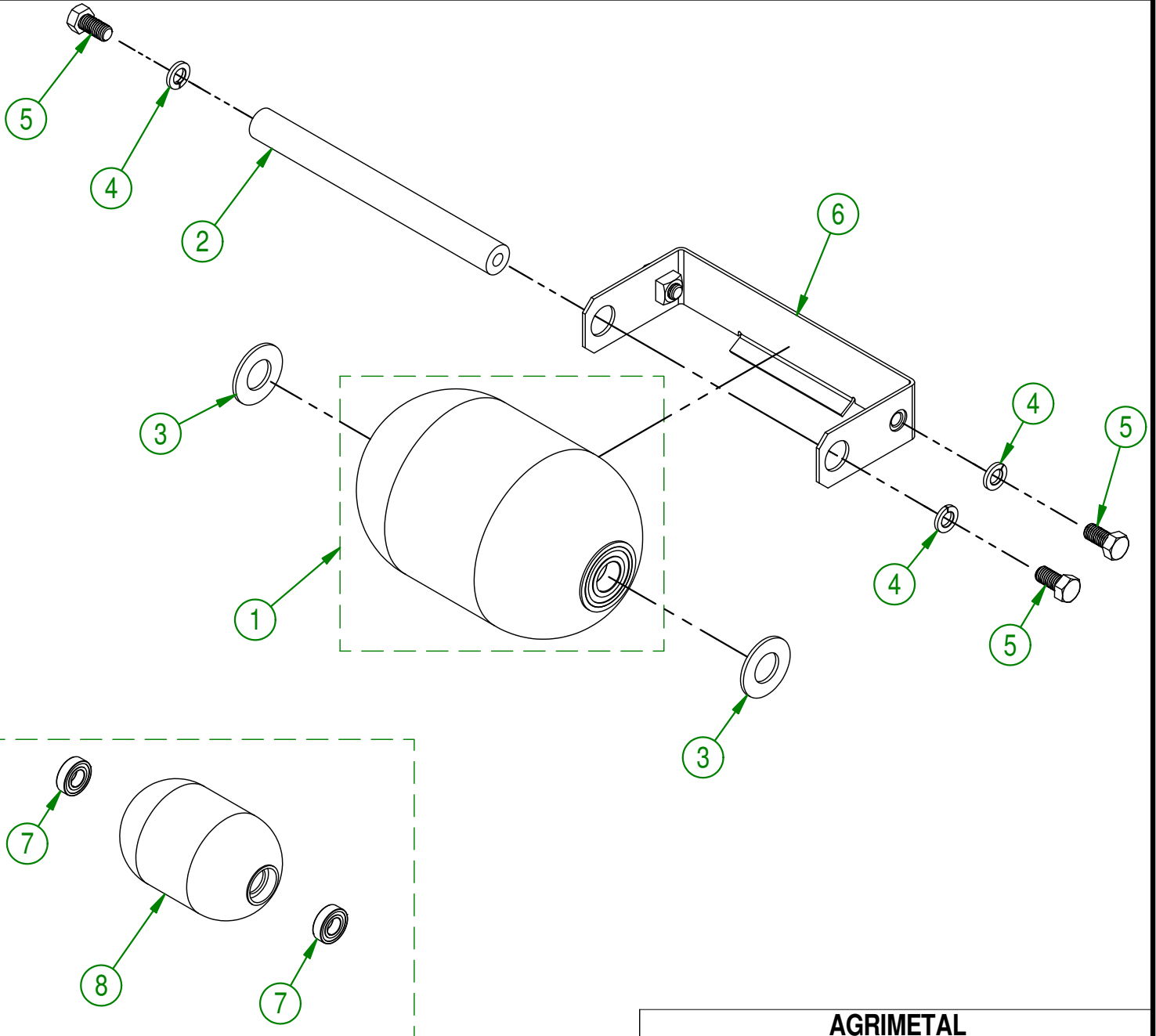

AGRIMETAL		
REAR ROLLER GROUP		
CREATION : 07-10-2016	ASSEMBLY :	22-57-0270
REVISION : 01-02-2019	AUTHOR :	Page 60 de 70

22-57-0280

#	PART #	Qty	TITLE
1	22-55-0360	1	ROLLER Ø 6"
2	22-13-1425	1	FRONT ROLLER SHAFT
3	28-42-0120	2	SPACER
4	NC02-32-0014	4	LOCK WASHER ZINC 1/2"
5	NC01-17-0247	2	HEX. BOLT GR2 ZINC 1/2-13 X 1"
6	22-50-0180	1	ROLL HOLDER ADJUSTABLE
7	28-13-2040	2	PIVOT ROLLER
8	01-01-1660	2	WASHER SPACER
9	NC02-25-0011	2	WASHER SAE ZINC 17/32 ID
10	NC01-17-0251	2	HEX. BOLT GR2 ZINC 1/2-13 X 2"
11	NC02-07-0020	2	HEX. NUT ZINC 1/2-13

22-55-0360

#	PART #	Qty	TITLE
12	NC14-75-0070	2	6205-2RS BEARING
13	22-46-0000	1	ROLLER

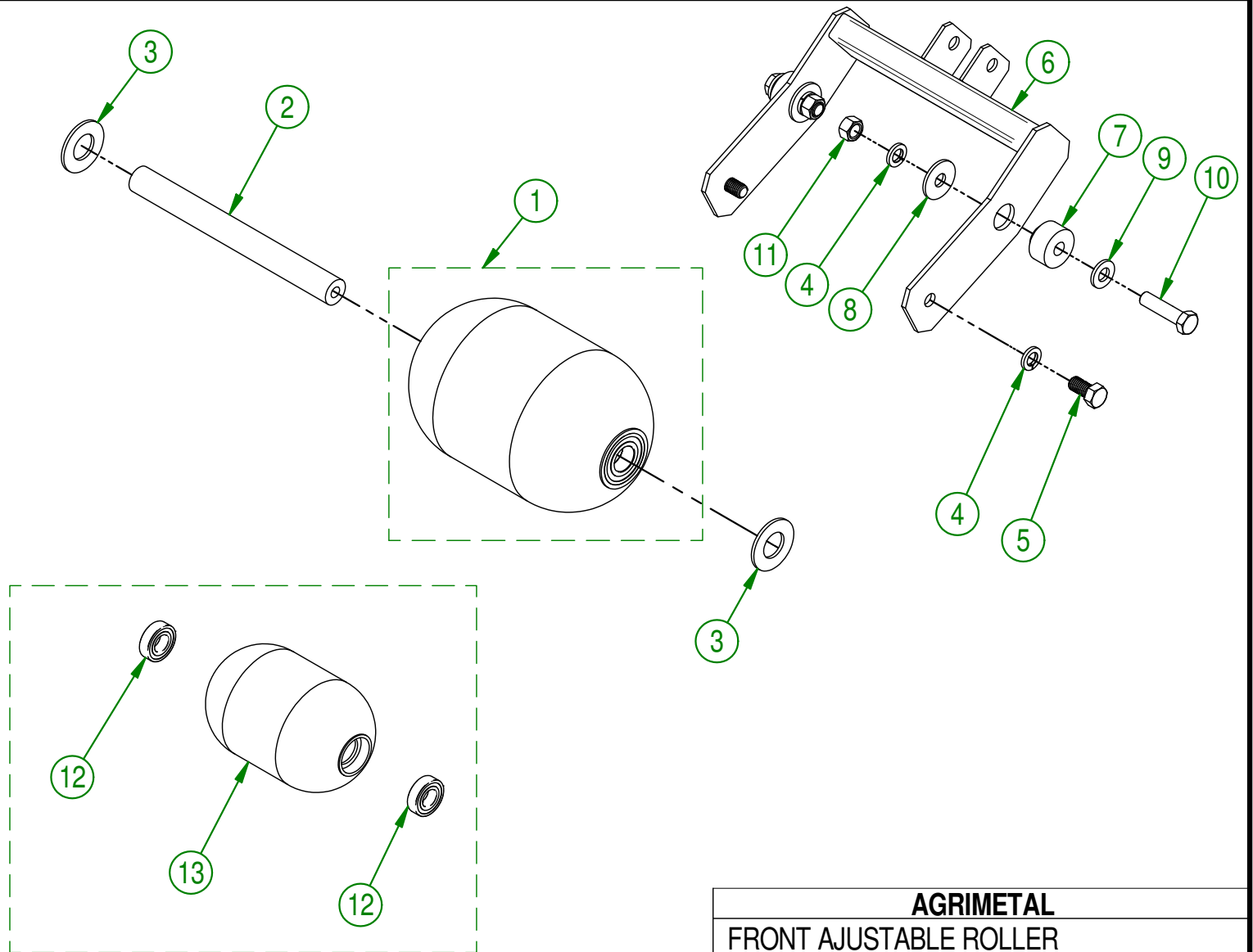

AGRIMETAL		
FRONT AJUSTABLE ROLLER		
CREATION : 07-10-2016	ASSEMBLY :	22-57-0280
REVISION : 15-11-2018	AUTHOR :	Page 61 de 70

#	PART #	Qty	TITLE
1	NCI3-25-0284	1	KRALOY TERMINAL BOX 2" X 2 13/16" X 4 9/16"
2	NCI3-25-0285	1	KRALOY BOX COVER 2 13/16" X 4 9/16"
3	16-55-0290	2	LIGHT SUPPORT ASSY
4	NCI3-25-0278	1	FIXING LIGHT REGISTRATION PLATE
5	22-55-0210	1	ASSEMBLY TRAILER CABLE CONNECTION 3 SPRIGS (RIGHT)
6	22-55-0215	1	ASSEMBLY TRAILER CABLE CONNECTION 3 PRIGS. (LEFT)
7	16-55-0043	1	TRAILER CONNECTION 4 SPRIGS
8	22-55-0220	1	ASSEMBLY TRAILER CABLE CONNECTION 4 SPRIGS
9	NC02-42-0086	2	SQUARE DRIVE SCREW #12 X 3/4"
10	NC01-17-0003	4	HEX. BOLT GR2 ZINC 1/4-20 X 5/8"
11	NC02-25-0007	4	WASHER ZINC 0.281 = 9/32
12	NC01-96-0009	4	NYLON-INSERT LOCKNUT ZINC 1/4-20
13	NCI3-25-0110	10	SNUG-FIT DAMPING LOOP CLAMP
14	NC01-78-0016	10	ALUMINIUM BLIND POP RIVET STEEL MANDREL 0.187 X 0.690
15	NCI3-25-0245	3	BLACK TIE RAP
16	NCI3-25-0388	1	TRAILER 7 WAY ROUND CONNECTOR WITH SPRING (OPTION)
17	NCI3-25-0381	1	TRAILER 7 FLAT WAY ROUND CONNECTOR (OPTION)

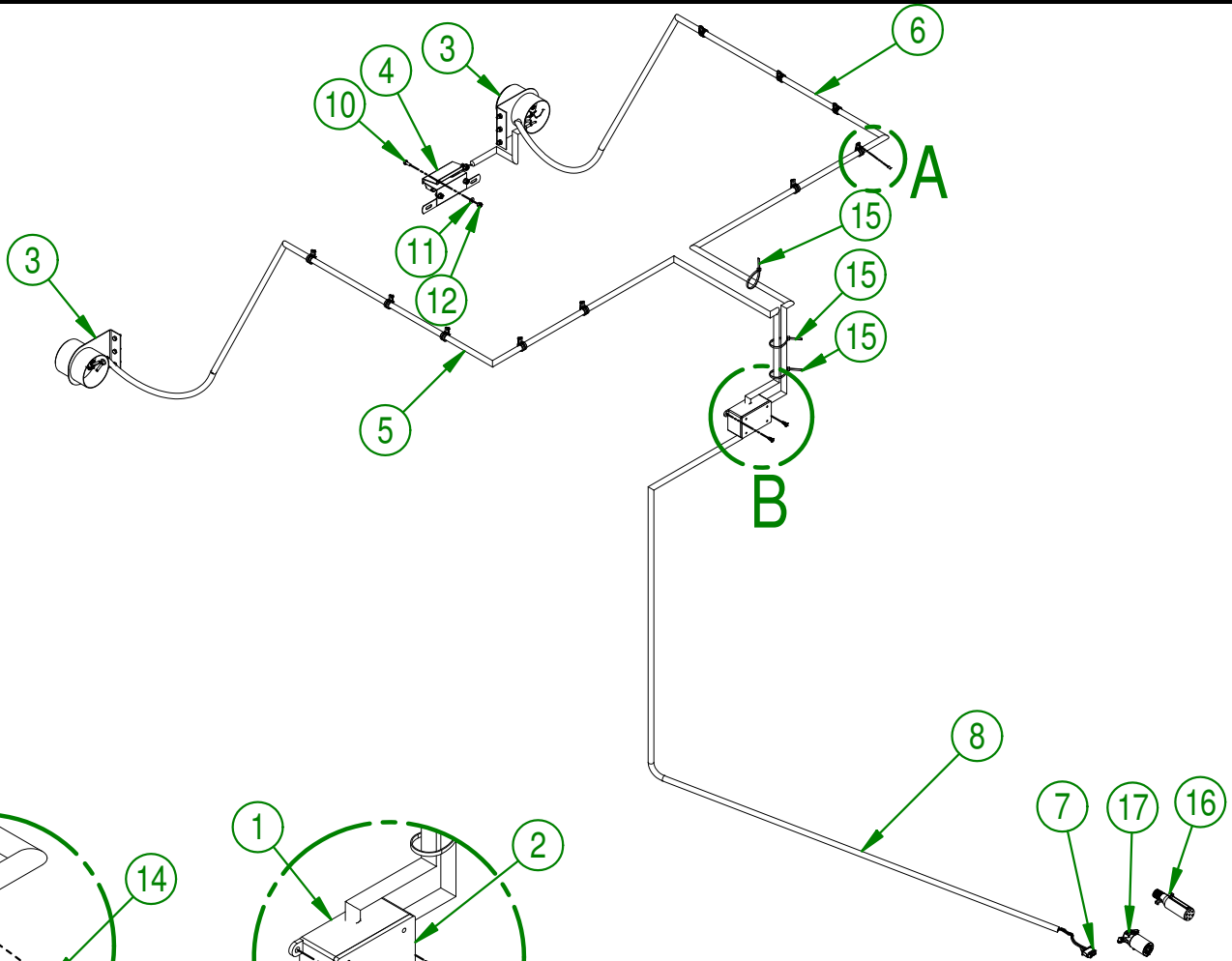

DETAIL A

DETAIL B

AGRIMETAL	
STOP AND TURN LIGHT KIT (OPTION)	
CREATION : 04/10/17	ASSEMBLY : 22-55-0205
REVISION : 06/04/18	AUTHOR : F.HÉLIE Page 62 de 70

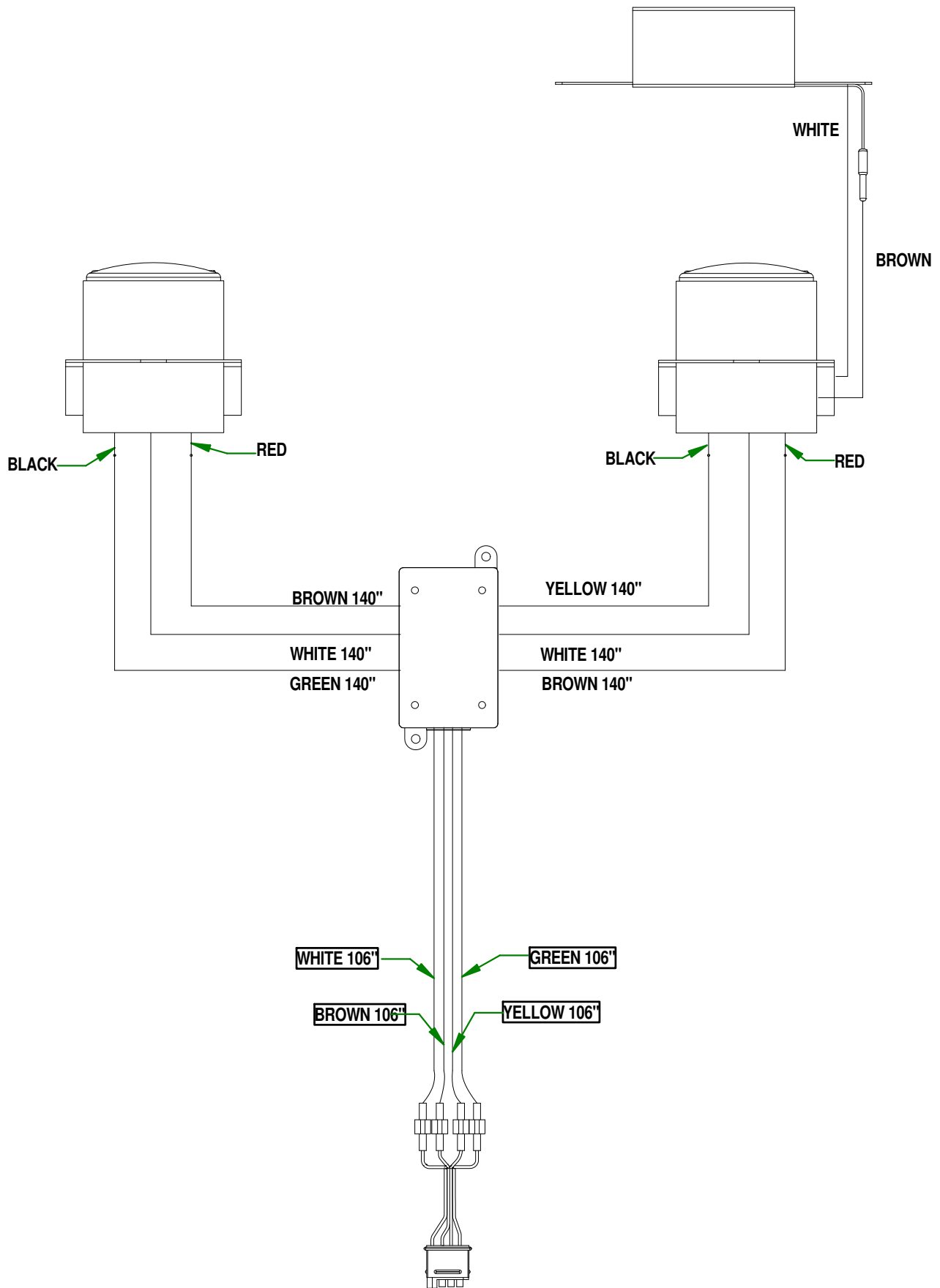

AGRIMETAL	
STOP AND TURN LIGHT KIT (OPTION)	
CREATION : 04/10/17	ASSEMBLY : 22-55-0205
REVISION : 06/04/18	AUTHOR : F.HÉLIE Page 63 de 70

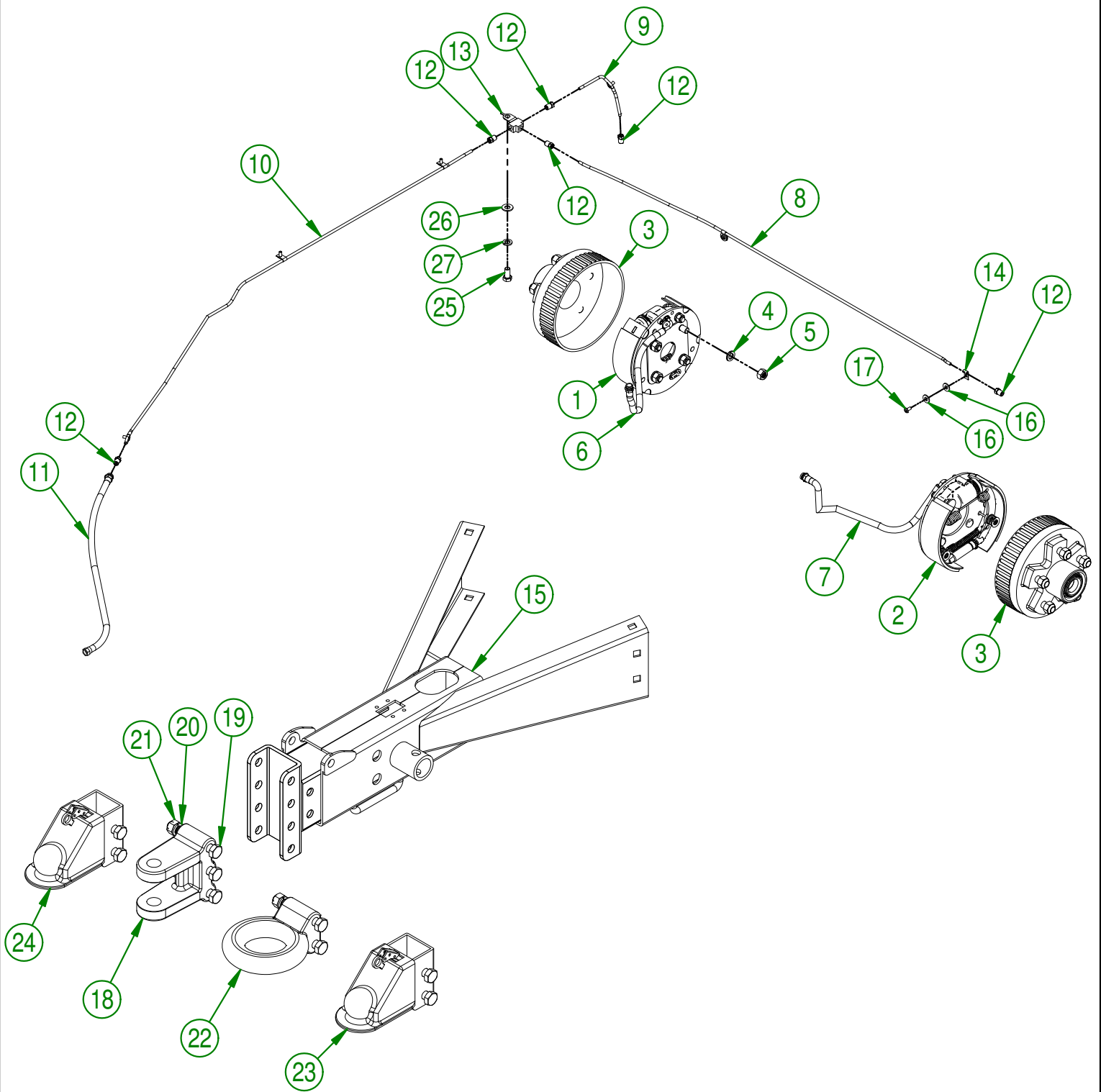

AGRIMETAL	
HYDRAULIC BRAKE KIT (OPTION)	
CREATION : 22/03/18	ASSEMBLY : 22-57-0295
REVISION : 04/05/18	AUTHOR : F.HÉLIE Page 64 de 70

#	PART #	Qty	TITLE
1	NC14-70-0634	1	BRAKE 7" X 1 3/4" UNI 2.5K RH
2	NC14-70-0635	1	BRAKE 7" X 1 3/4" UNI 2.5K LH
3	NC14-70-0638	2	HUB/DRUM KIT 5/4.5 HYD.
4	NC14-70-0637	8	LOCK WASHER ZINC 0.4375 = 7/16
5	NC14-70-0636	8	HEX NUT 7/16" NF
6	NC14-70-0640	1	(BRAKE) FLEXIBLE HOSE 18"
7	NC14-70-0640	1	(BRAKE) FLEXIBLE HOSE 18"
8	22-55-0645	1	RIGID BRAKE LINE 3/16" X 35" LG.
9	22-55-0650	1	RIGID BRAKE LINE 3/16" X 7" LG.
10	22-55-0655	1	RIGID BRAKE LINE 3/16" X 44" LG.
11	NC14-70-0624	1	FLEXIBLE HOSE 18"
12	NC14-70-0623	6	BOLT FOR RIGID HOSE 3/16"
13	NC14-70-0630	1	T UNION 3/16" WITH BRACKET (3XKIT MV)
14	NC13-25-0391	6	LOOP CLAMPS
15	22-55-0640	1	ACTIVATOR 10 & ADJUSTABLE SUPPORT (OPTION)
16	NC02-25-0007	4	WASHER ZINC 0.281 = 9/32
17	NC01-78-0015	6	RIVET 3/16"
18	NC13-80-0241	1	ADJUSTABLE 1" CLEVIS (3 HOLES)
19	NC01-33-0406	9	HEX. BOLT GR8 ZINC 5/8-11 X 4 1/2" LG
20	NC02-32-0016	9	LOCK WASHER ZINC 5/8"
21	NC02-07-0022	9	HEX. NUT ZINC 5/8-11
22	NC14-70-0601	1	ADJUSTABLE 3" LUNETTE RING (2 HOLES)
23	NC14-70-0620	1	ADJUSTABLE 2" BALL COUPLER
24	NC14-70-0602	1	ADJUSTABLE 2-5/16" BALL COUPLER (2 HOLES)
25	NC01-17-0112	1	HEX. BOLT GR2 ZINC 3/8-16 X 3/4"
26	01-01-2485	1	FLAT WASHER 14 GA X 13/16"OD X 25/64" ID
27	NC02-32-0012	1	LOCK WASHER ZINC 3/8"

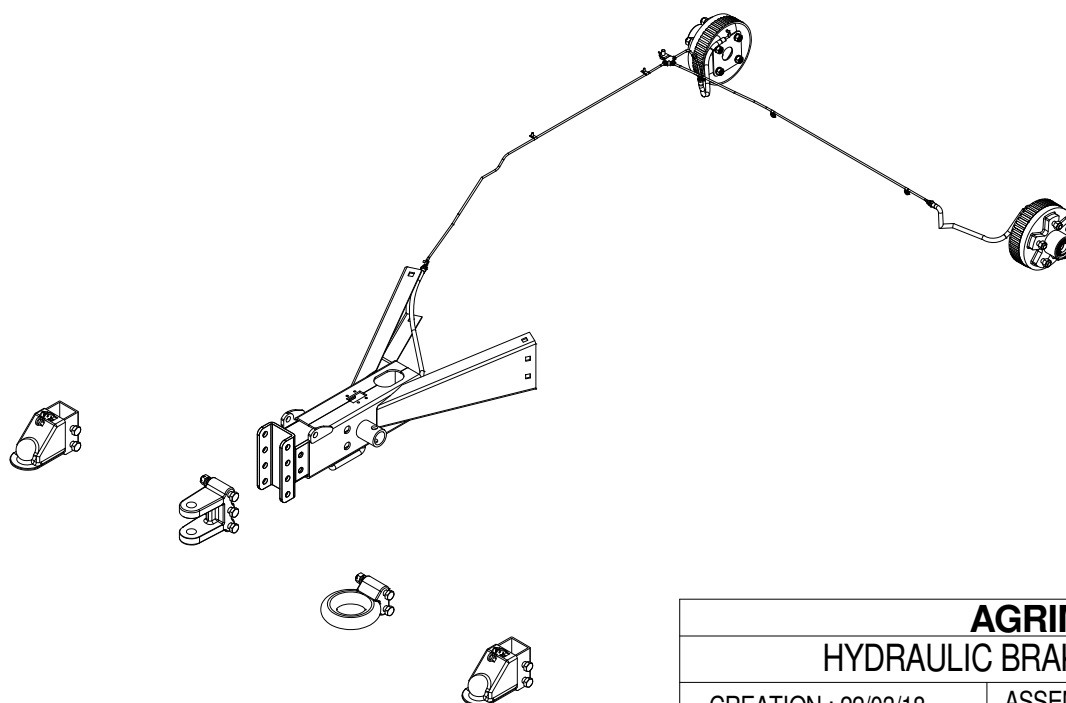

AGRIMETAL	
HYDRAULIC BRAKE KIT (OPTION)	
CREATION : 22/03/18	ASSEMBLY : 22-57-0295
REVISION : 04/05/18	AUTHOR : F.HÉLIE Page 65 de 70

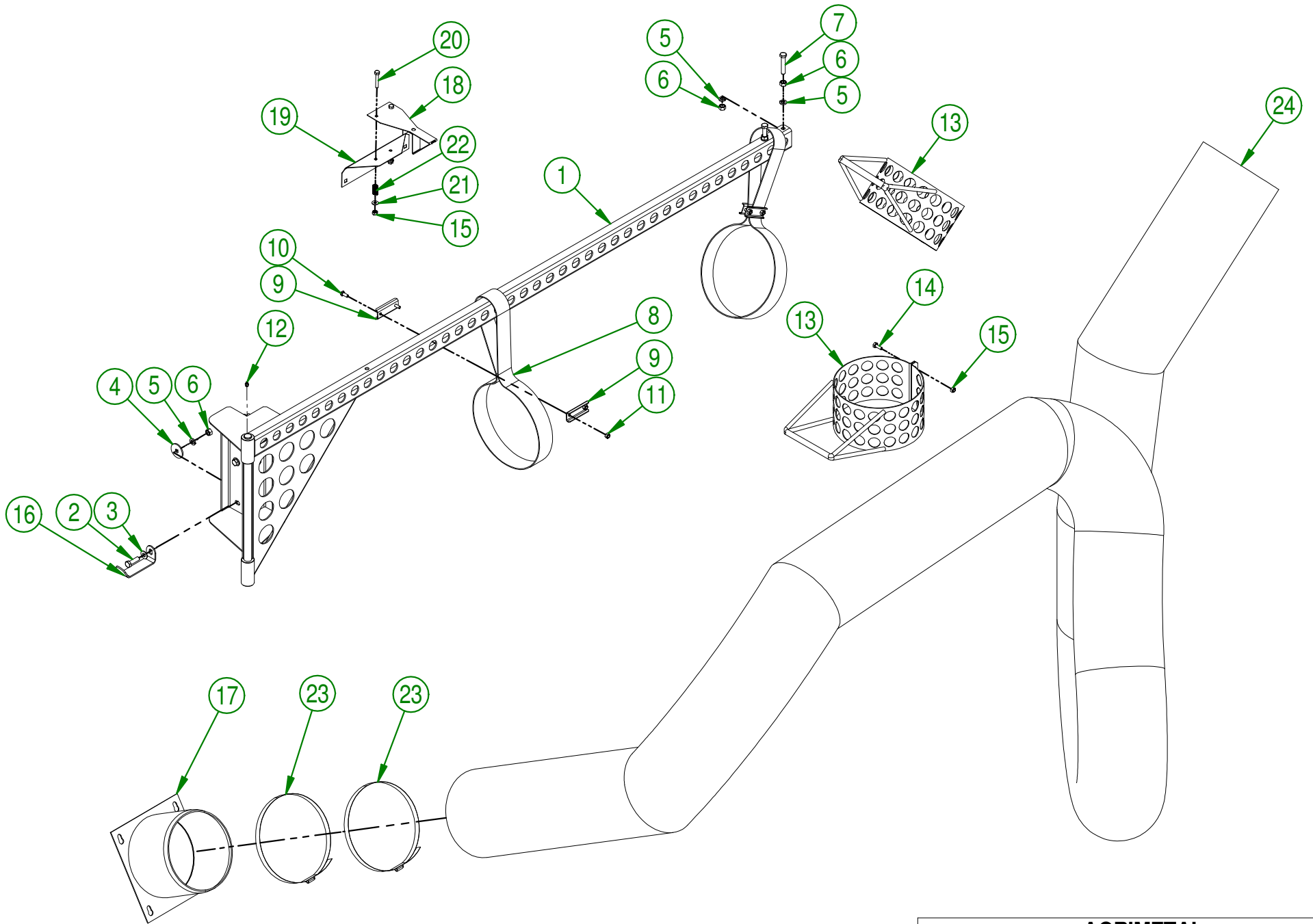

AGRIMETAL		
HOSE KIT (OPTION)		
CREATION : 2017-10-06	ASSEMBLY :	22-57-0250
REVISION : 2018-05-04	AUTHOR :	Page 66 de 70

#	PART #	Qty	TITLE
1	16-50-0120	1	FLEXIBLE HOSE SUPPORT
2	NC01-17-0115	6	HEX. BOLT GR2 ZINC 3/8-16 X 1 1/4"
3	01-01-2485	6	FLAT WASHER
4	01-33-0010	6	WASHER
5	NC02-32-0012	10	LOCK WASHER ZINC 3/8"
6	NC02-07-0018	10	HEX. NUT ZINC 3/8-16
7	NC01-17-0118	2	HEX. BOLT GR2 ZINC 3/8-16 X 2"
8	22-41-4000	2	YELLOW STRAP ONLY
9	16-01-2650	4	STRAP SECURING
10	NC01-29-0003	4	HEX. BOLT GR5 ZINC 1/4-28 X 5/8"
11	NC01-97-0004	4	NYLON-INSERT LOCKNUT ZINC 1/4-28
12	NC01-69-0785	2	STRAIGHT GREASE FITTING 1/4-28
13	16-50-0125	2	OPT. VACUUM PIPE HANDLE
14	NC01-17-0004	6	HEX. BOLT GR2 ZINC 1/4-20 X 3/4"
15	NC01-96-0009	8	NYLON-INSERT LOCKNUT ZINC 1/4-20
16	22-01-1540	1	FLEXIBLE HOSE HANDLE HOOK
17	22-50-0160	1	HOSE ADAPTOR 8" DIA.
18	22-50-0070	1	HOSE SUPPORT LOCK
19	22-01-3120	1	HOSE SUPPORT LOCK BRACKET
20	NC01-17-0008	2	HEX. BOLT GR2 ZINC 1/4-20 X 1 1/2"
21	NC02-25-0007	2	WASHER ZINC 0.281 = 9/32
22	NC13-85-0027	2	COMPRESSION SPRING .500" DIA. X 1 3/4" LG.
23	NC01-65-0077	2	HOSE CLAMPS (HS128)
24	NC13-40-0008	1	FLEXIBLE VACUUM TUBE 8" DIA. X 192" LG.

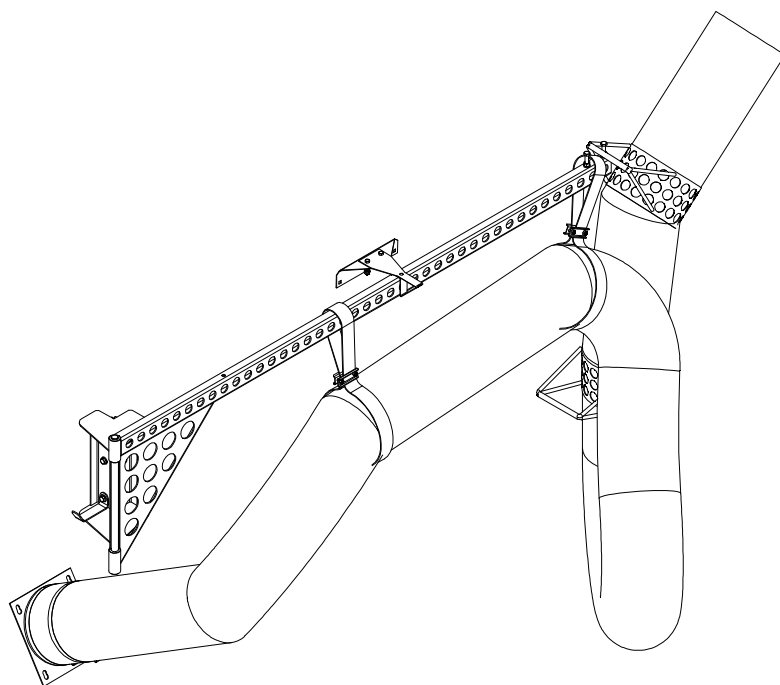

AGRIMETAL
HOSE KIT (OPTION)

CREATION : 06/10/17
REVISION : 04/05/18

ASSEMBLY : **22-57-0250**

AUTHOR : F.HÉLIE Page 67 de 70

#	PART #	Qty	TITLE
1	NC13-30-0237	1	PLASTIC TUBE FOR OPERATOR'S MANUAL
2	NC01-04-0002	3	CARR. BOLT GR2 ZINC 1/4-20 X 5/8"
3	NC02-14-0017	3	FLANGED NUT GR. B 1/4-20
4	NC02-25-0007	3	WASHER ZINC 0.281 = 9/32
5	22-98-0530	1	OPERATION MANUAL

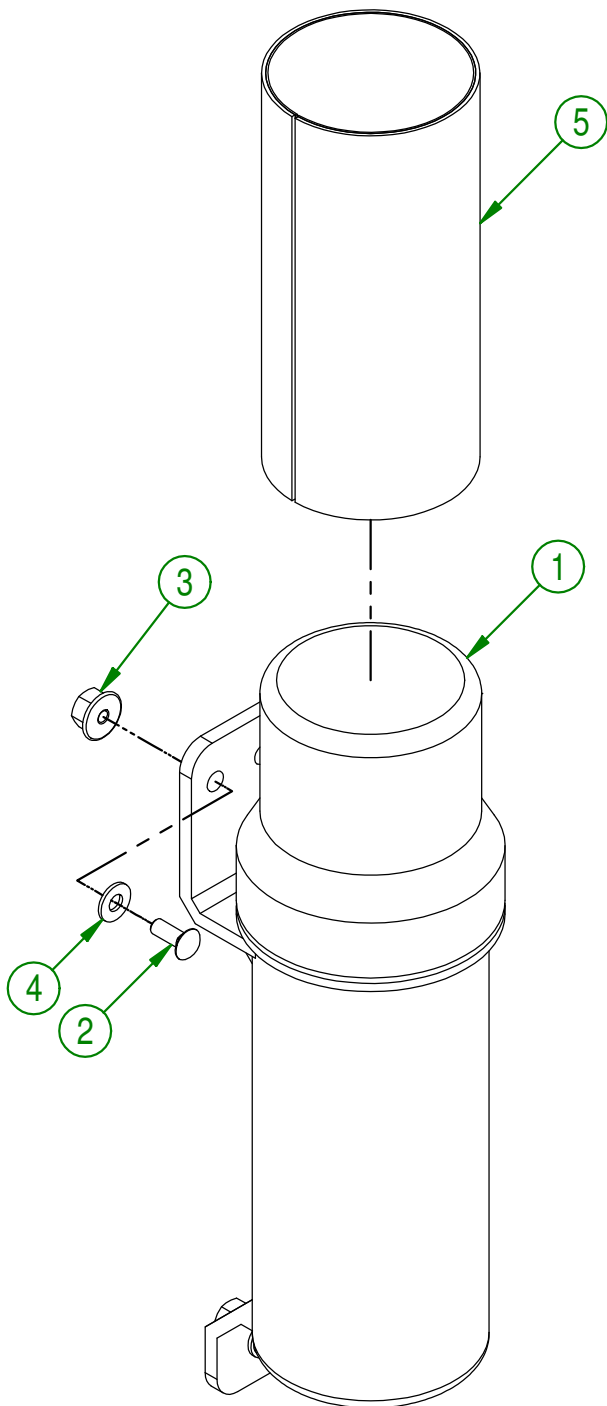

AGRIMETAL	
ASSEMBLY OPERATOR MANUEL TUBE	
CREATION : 2016-10-18	ASSEMBLY : 22-57-0595
REVISION : 2017-11-14	AUTHOR : S.B. Page 68 de 70

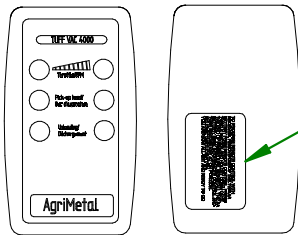

REMOTE CONTROL

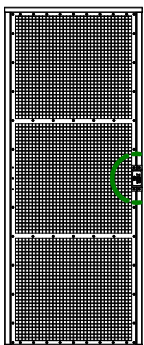

FILTER KIT (OPTION)

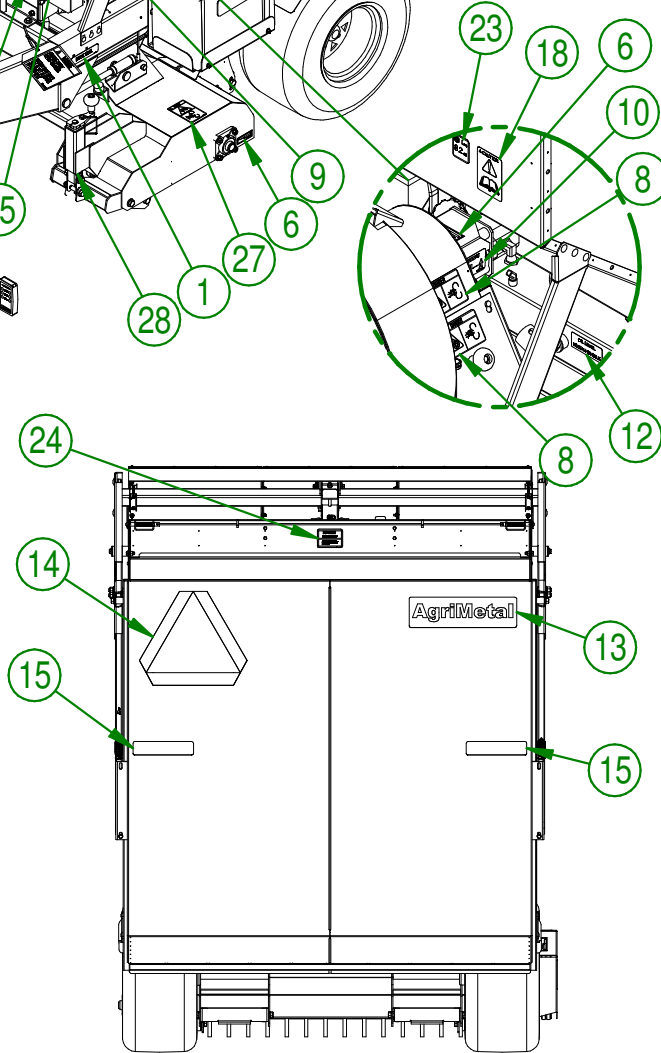
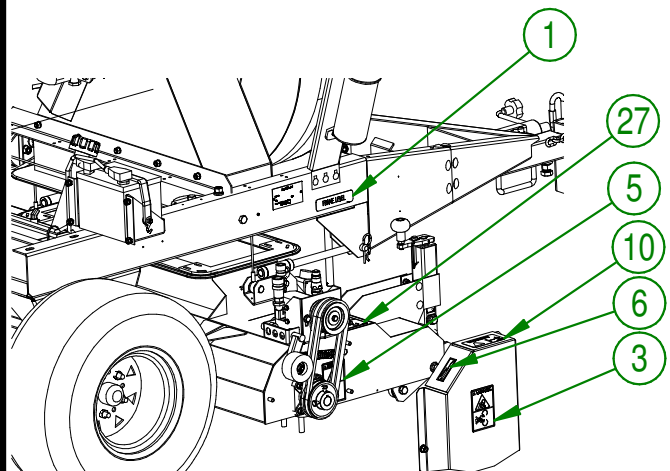
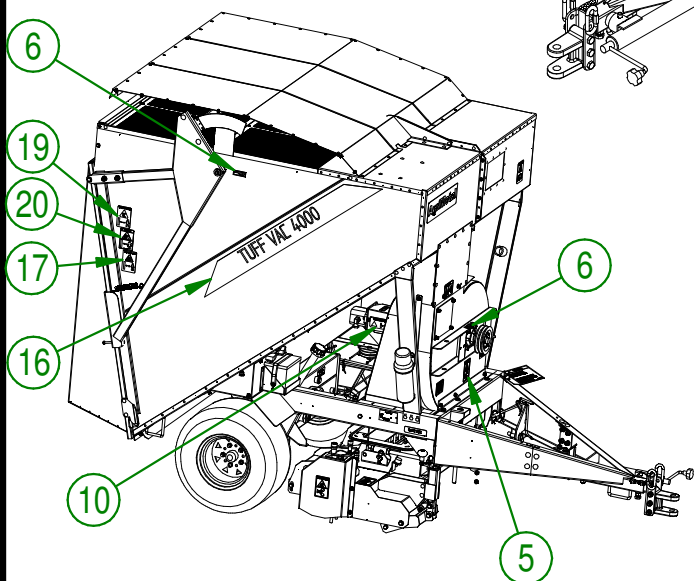
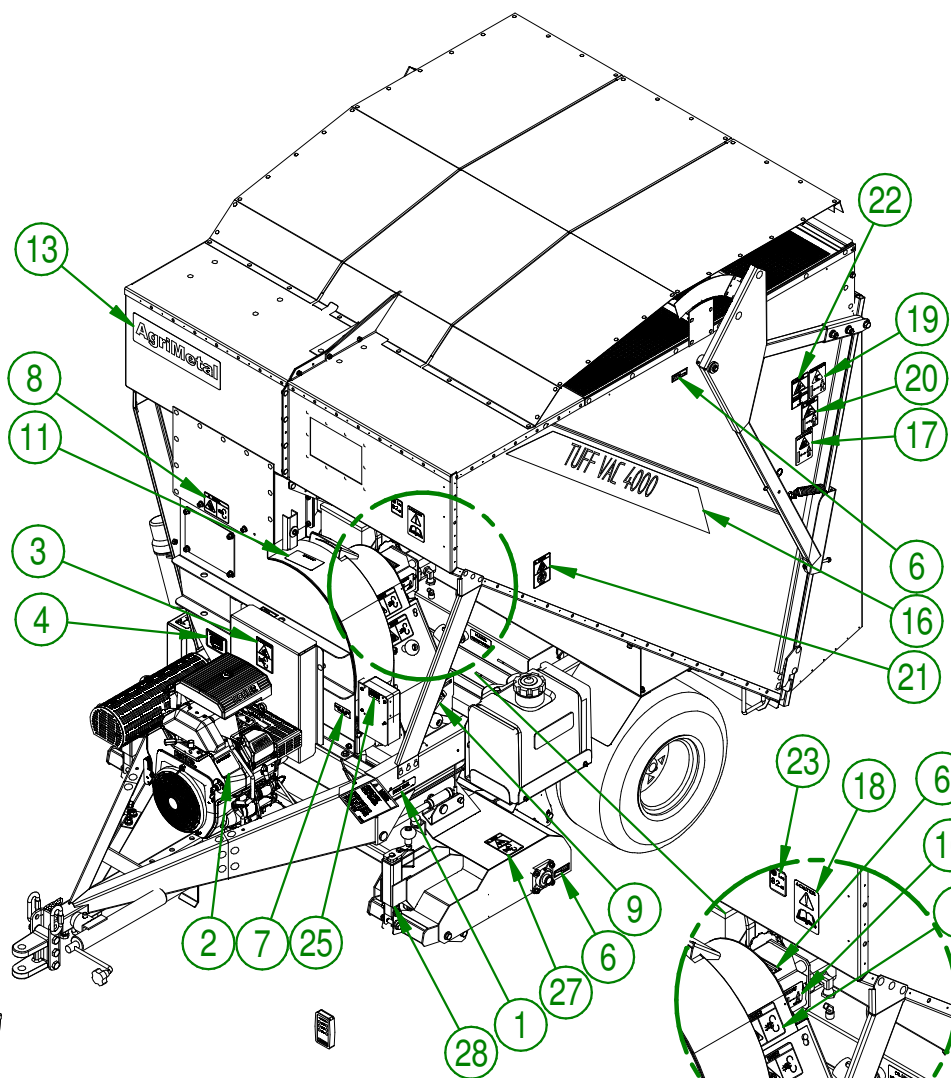

AGRIMETAL	
TUFF VAC 4000 GAZ	
CREATION : 28/05/18	ASSEMBLY : 22-99-0537
REVISION : 10/09/21	AUTHOR : F.HÉLIE

#	PART #	Qty	TITLE
1	NC13-33-0052	2	STICKER FRAME LEVEL
2	NC13-33-0178	1	STICKER IMPORTANT PLEASE CHECK OIL LEVEL...
3	NC13-33-0287	4	STICKER WARNING
4	NC13-33-0154	1	STICKER IMPORTANT
5	NC13-33-0282	4	STICKER DANGER
6	NC13-33-0024	10	STICKER GREASE HERE
7	NC13-33-0227	1	STICKER FUSE 15 AMP MAXIMUM
8	NC13-33-0249	3	STICKER DANGER
9	NC13-33-0119	1	STICKER HEAD HOSE
10	NC13-33-0288	5	STICKER WARNING HIGH-PRESSURE LIQUID
11	NC13-33-0121	1	STICKER IMPORTANT
12	NC13-33-0003	1	STICKER OIL LEVEL
13	NC13-33-0001	2	STICKER AGRIMETAL
14	NC13-33-0102	1	STICKER TRIANGLE FOR SLOW MACHINARY
15	NC13-33-0149	2	STICKER RED REFLECTOR
16	NC13-33-0094	2	STICKER (TUFF VAC 4000)
17	NC13-33-0192	2	STICKER (PROJECTION RISK)
18	NC13-33-0183	1	STICKER CAUTION OPERATION MANUAL
19	NC13-33-0268	2	STICKER WARNING
20	NC13-33-0260	2	STICKER WARNING
21	NC13-33-0185	1	STICKER PICTOGRAM (FIRE + CIGARETTE)
22	NC13-33-0284	1	STICKER WARNING
23	NC13-33-0338	1	STICKER 82 DB
24	NC13-33-0100	1	STICKER IMPORTANT CLOSE AND LATCH SCREEN
25	NC13-33-0251	2	STICKER TO PROGRAM REMOTE CONTROL
26	NC13-33-0107	2	STICKER (TOP MIDDLE)
27	NC13-33-0190	6	STICKER WARNING ROTATING BLADE HAZARD
28	NC13-33-0155	6	STICKER RULES 3"

AGRIMETAL

TUFF VAC 4000 GAZ

CREATION : 28/05/18
REVISION : 10/09/21

ASSEMBLY : **22-99-0537**
AUTHOR : F.HÉLIE