

AgriMetal

PARTS LIST

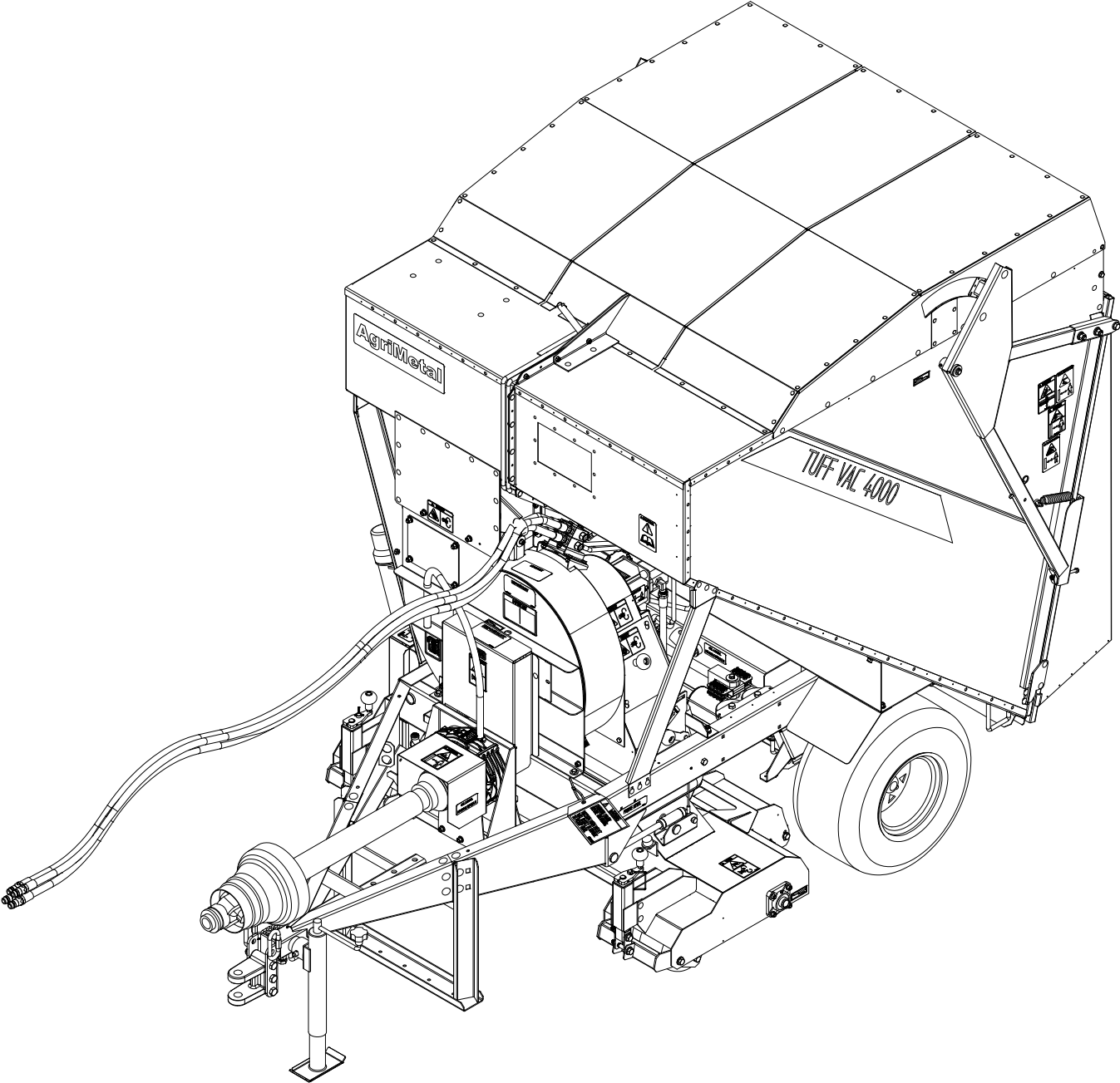

TUFF VAC 4000 PTO

#	PART #	QTY	TITLE
1	22-55-0030	1	SCREEN 1/2"
2	22-55-0025	1	SCREEN 1/4" ASS'Y
3	22-50-0157	1	SHIPPING LEG
4	22-55-0320	1	JACK
5	22-55-0265	2	WASHABLE HARD SURFACE FILTER KIT (OPTION)
6	22-55-0053	1	NYLON BRISTLE ROTARY BRUSH HEAD ASS'Y
7	22-55-0051	1	DETHATCHING HEAD WITH KNIVES SYSTEM ASS'Y
8	22-55-0046	1	PICK UP HEAD WITH ROTATIVE BRUSH (RUBBER FINGER)
9	22-57-0195	2	ARM PICK UP HEAD
10	NCI3-50-0123	1	WARNING TYVEK STICKER
11	25-55-0710	1	SERIAL NUMBER PLATE
12	NCI7-11-0006	1	EXPANDING BOOT

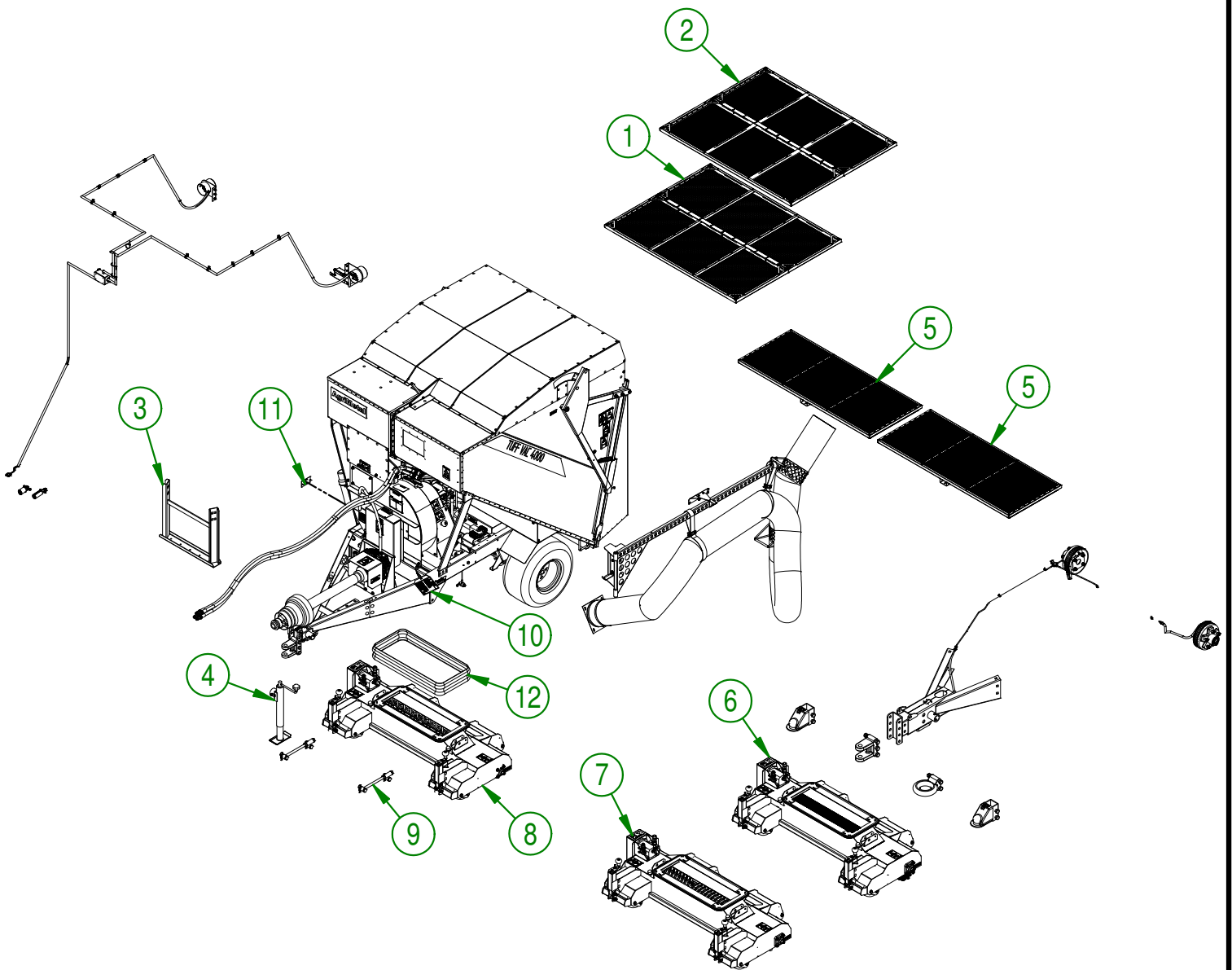

AGRIMETAL		
TUFF VAC 4000 PTO		
CREATION : 17/04/18	ASSEMBLY :	
REVISION : 01/11/18	AUTHOR : F.HÉLIE	Page 1 de 67

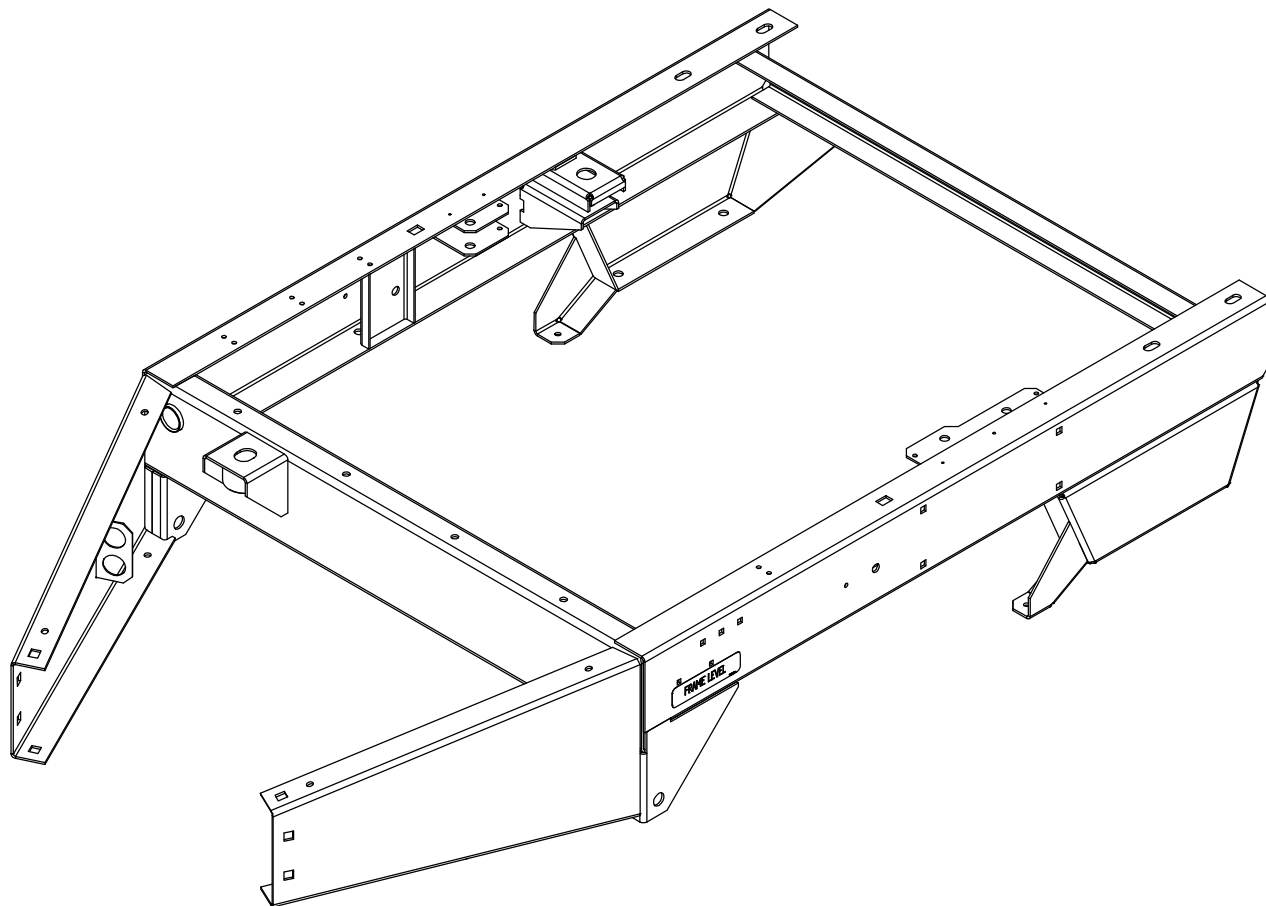

AGRIMETAL

ASSEMBLY FRAME " STICKER INCLUDED" (PTO & GAZ)

CREATION : 14/11/17
REVISION : 15/06/18

ASSEMBLY : **22-57-0580**

AUTHOR : F.HÉLIE

Page 2 de 67

#	PART #	Qty	TITLE
1	NC01-17-0402	1	HEX. BOLT GR2 ZINC 5/8-11 X 3 1/2"
2	NC02-22-0013	1	WASHER ZINC 5/8 ID X 1 1/2 OD
3	NC01-96-0016	1	NYLON INSERT NUT 5/8-11
4	22-50-0083	1	EXTENSION HITCH
5	22-01-0956	1	LEFT HITCH JOINT BRACKET
6	22-01-0961	1	RIGHT HITCH JOINT BRACKET
7	NC01-04-0233	16	CARR. BOLT GR2 ZINC 1/2-13 X 1"
8	01-01-0925	16	WASHER
9	NC02-32-0014	16	LOCK WASHER ZINC 1/2"
10	NC02-07-0020	16	HEX. NUT ZINC 1/2-13
11	22-50-0075	1	TELESCOPING HITCH
12	NC01-33-0406	3	HEX. BOLT GR8 ZINC 5/8-11 X 4 1/2" LG
13	NC02-32-0016	3	LOCK WASHER ZINC 5/8"
14	NC02-07-0022	4	HEX. NUT ZINC 5/8-11
15	NC01-17-0394	1	HEX. BOLT GR2 ZINC 5/8-11 X 1 1/2"
16	16-41-0040	1	CHAIN 58"
17	NC01-75-0007	2	CONNECTING LINK APROUVED 1/2 3300/LBS WLL
18	NC13-80-0241	1	ADJUSTABLE 1" CLEVIS (3 HOLES)

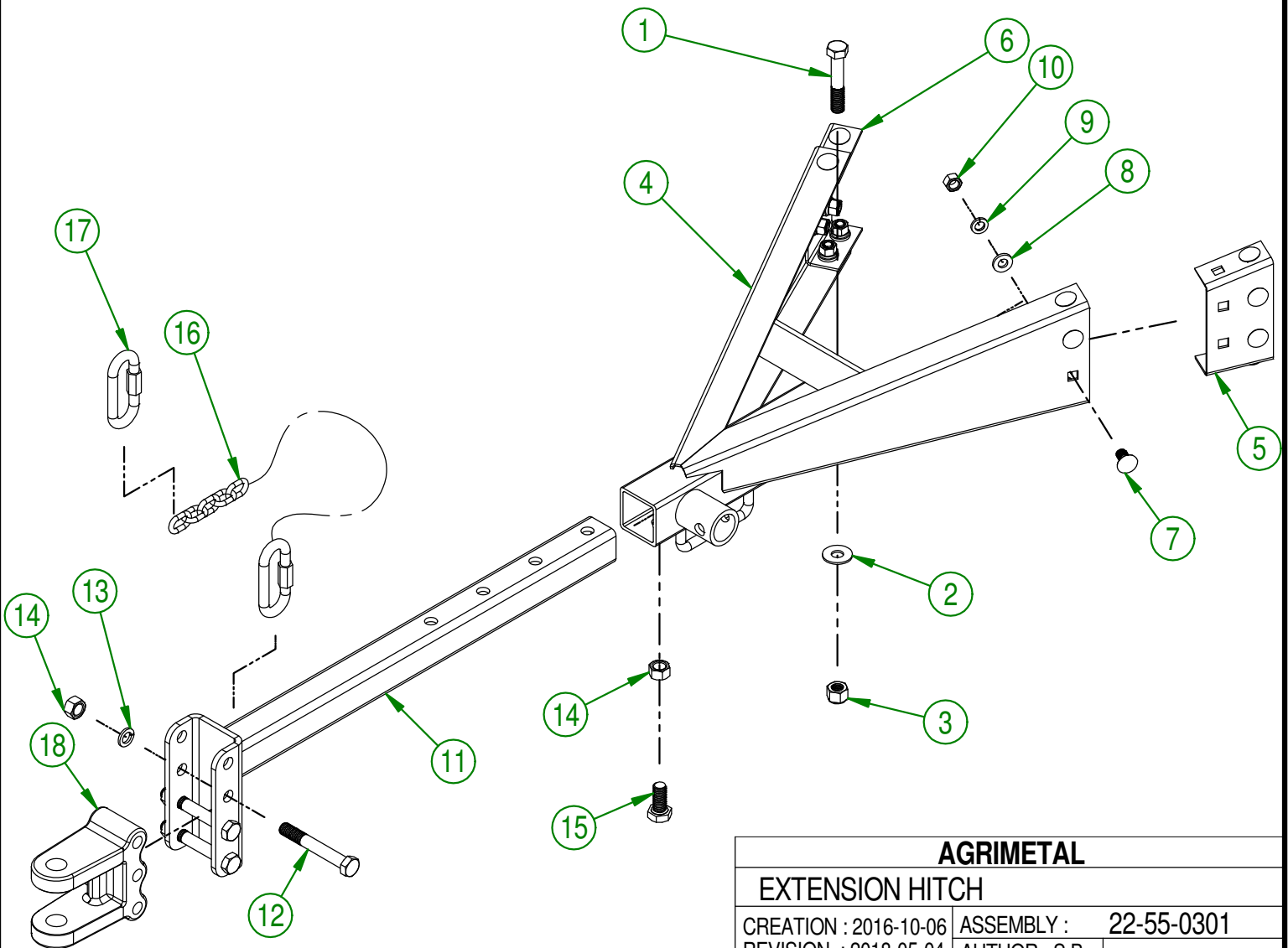

AGRIMETAL			
EXTENSION HITCH			
CREATION : 2016-10-06	ASSEMBLY :	22-55-0301	
REVISION : 2018-05-04	AUTHOR : S.B.	Page 3 de 67	

22-57-0077

#	PART #	Qty	TITLE
1	01-34-0101	1	A624A RATIO 1:5 15 TRANSMISSION
2	01-57-0535	1	PTO GUARD "STICKER INCLUDED"
3	22-01-0970	1	TRANSMISSION SUPPORT
4	22-50-0085	1	TRANSMISSION BASE MOUNT
5	NC01-45-0184	6	HEX. BOLT GR8.8 ZINC 8MM X 20MM
6	NC02-22-0008	6	WASHER ZINC 5/16"
7	NC02-32-0011	6	LOCK WASHER ZINC 5/16"
8	NC13-65-0003	1	BRASS ELBOW 90 3/8 FEM. NPT X 3/8 MALE NPT
9	NC01-17-0112	4	HEX. BOLT GR2 ZINC 3/8-16 X 3/4"
10	NC02-32-0012	7	LOCK WASHER ZINC 3/8"
11	01-01-2485	7	FLAT WASHER 14 GA X 13/16"OD X 25/64" ID
12	NC01-04-0107	3	CARR. BOLT GR2 ZINC 3/8-16 X 3/4"
13	NC02-07-0018	3	HEX. NUT ZINC 3/8-16
14	NC13-65-0010	1	BRASS NIPPLE 3/8" X 1 1/2" LG.
15	NC02-44-0204	1	SET SCREW NPTF 3/8-18
16	16-39-0435	1	TAPERED QD BUSHING SDS X 1 1/4" K.W. 5/16"
17	NC14-62-0089	1	PULLEY QD 2V 1/2-5/8 5.950D X SDS 2B56
18	06-41-0900	1	SQUARE KEY 5/16" X 5/16" X 1 3/4" LG.
19	22-04-6805	4	FLAT WASHER BEARING BASE
20	22-09-1200	2	BUSHING
21	NC01-17-0467	2	HEX. BOLT GR2 ZINC 3/4-10 X 2"
22	NC02-32-0017	2	LOCK WASHER ZINC 3/4"
23	NC02-07-0023	2	HEX. NUT ZINC 3/4-10
24	NC14-25-2558	1	HI-POWER V BELT 2RB-44
25	NC01-65-0055	1	HOSE CLAMP COLLAR
26	22-55-0065	1	BELT TENSION KIT ASS'Y
27	16-46-0525	1	OVER FLOW TRANSMISSION HOSE 39" LG.
28	28-34-0030	1	PTO SHAFT T60 X 45.98"
29	NC13-25-0229	3	BLACK TIE RAP

22-55-0065

#	PART #	Qty	TITLE
30	22-50-0200	1	WELD ASSEMBLY TENSIONER PIVOT
31	NC02-07-0023	1	HEX. NUT ZINC 3/4-10
32	22-04-6805	1	FLAT WASHER BEARING BASE
33	NC13-86-0083	1	BLUE SPRING 1/2" ID X 1" OD X 8"
34	22-42-0125	1	TENSIONER GUIDE

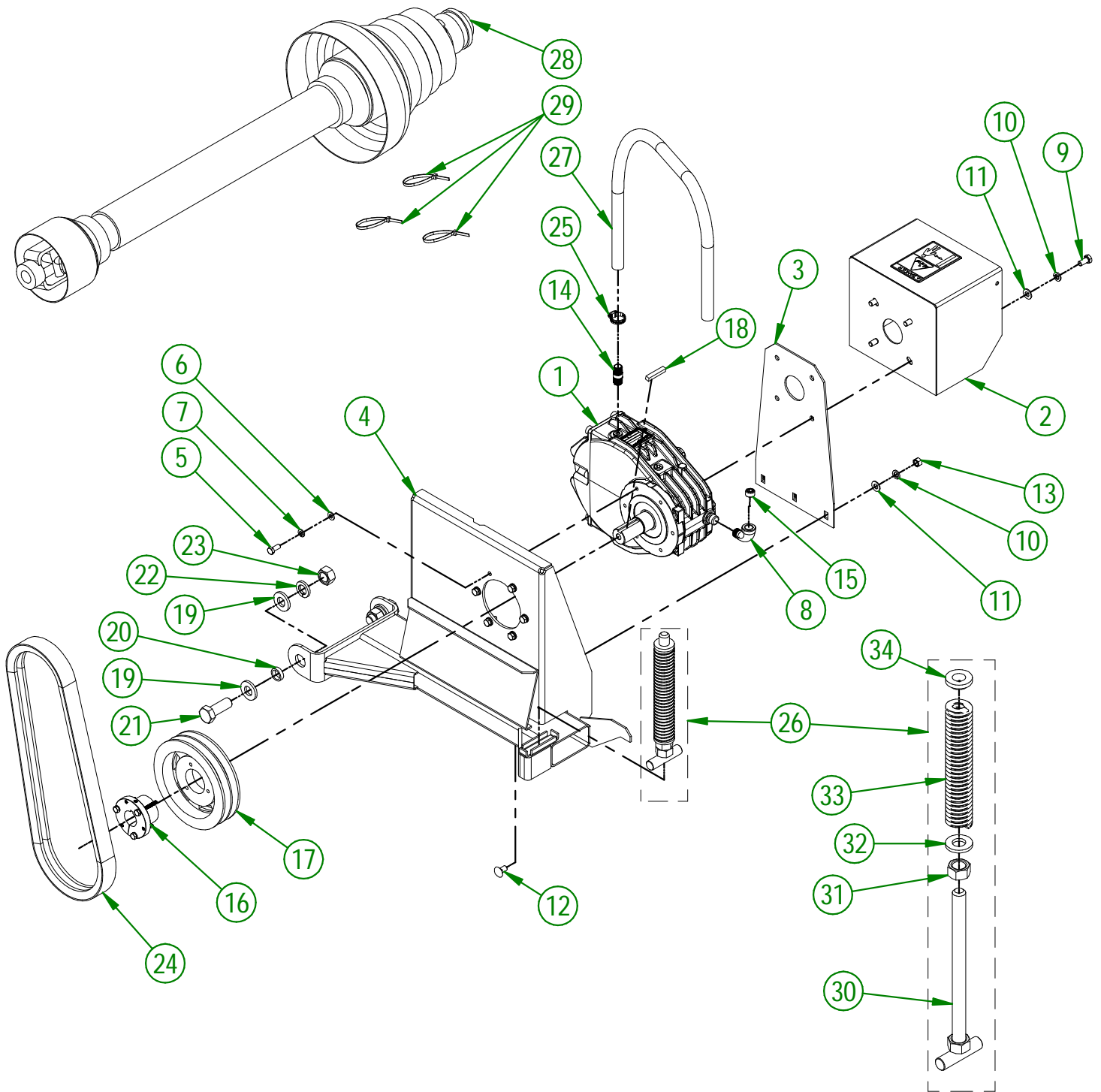

USE THESE PIECES ONLY IF YOUR SERIAL NUMBER IS AFFECTED:

BETWEEN #39489 & #42088

AGRIMETAL	
TRANSMISSION BASE MOUNT GROUP	
CREATION : 12/01/21	ASSEMBLY : 22-57-0078
REVISION : 15/12/25	AUTHOR : F.HÉLIE

22-57-0078

#	PART #	Qty	TITLE
1	01-34-0101	1	A624A RATIO 1:5 15 TRANSMISSION
2	01-57-0535	1	PTO GUARD "STICKER INCLUDED"
3	22-01-0970	1	TRANSMISSION SUPPORT
4	22-50-0085	1	TRANSMISSIOIN BASE MOUNT
5	NC01-45-0184	6	HEX. BOLT GR8.8 ZINC 8MM X 20MM
6	NC02-22-0008	6	WASHER ZINC 5/16"
7	NC02-32-0011	6	LOCK WASHER ZINC 5/16"
8	NC13-65-0003	1	BRASS ELBOW 90 3/8 FEM. NPT X 3/8 MALE NPT
9	NC01-17-0112	4	HEX. BOLT GR2 ZINC 3/8-16 X 3/4"
10	NC02-32-0012	7	LOCK WASHER ZINC 3/8"
11	01-01-2485	7	FLAT WASHER 14 GA X 13/16"OD X 25/64" ID
12	NC01-04-0107	3	CARR. BOLT GR2 ZINC 3/8-16 X 3/4"
13	NC02-07-0018	3	HEX. NUT ZINC 3/8-16
14	NC13-65-0010	1	BRASS NIPPLE 3/8" X 1 1/2" LG.
15	NC02-44-0204	1	SET SCREW NPTF 3/8-18
16	16-39-0435	1	TAPERED QD BUSHING SDS X 1 1/4" K.W. 5/16"
17	NC14-62-0231	1	PULLEY QD 2VI/2-5/8 X 7.125 OD X SDS 2B68
18	06-41-0900	1	SQUARE KEY 5/16" X 5/16" X 1 3/4" LG.
19	22-04-6805	4	FLAT WASHER BEARING BASE
20	22-09-1200	2	BUSHING
21	NC01-17-0467	2	HEX. BOLT GR2 ZINC 3/4-10 X 2"
22	NC02-32-0017	2	LOCK WASHER ZINC 3/4"
23	NC02-07-0023	2	HEX. NUT ZINC 3/4-10
24	NC14-25-2560	1	HI-POWER V BELT 2RB-46
25	NC01-65-0055	1	HOSE CLAMP COLLAR
26	22-55-0065	1	BELT TENSION KIT ASS'Y
27	16-46-0525	1	OVER FLOW TRANSMISSION HOSE 39" LG.
28	28-34-0030	1	PTO SHAFT T60 X 45.98"
29	NC13-25-0229	3	BLACK TIE RAP

22-55-0065

#	PART #	Qty	TITLE
30	22-50-0200	1	WELD ASSEMBLY TENSIONER PIVOT
31	NC02-07-0023	1	HEX. NUT ZINC 3/4-10
32	22-04-6805	1	FLAT WASHER BEARING BASE
33	NC13-86-0083	1	BLUE SPRING 1/2" ID X 1" OD X 8"
34	22-42-0125	1	TENSIONER GUIDE

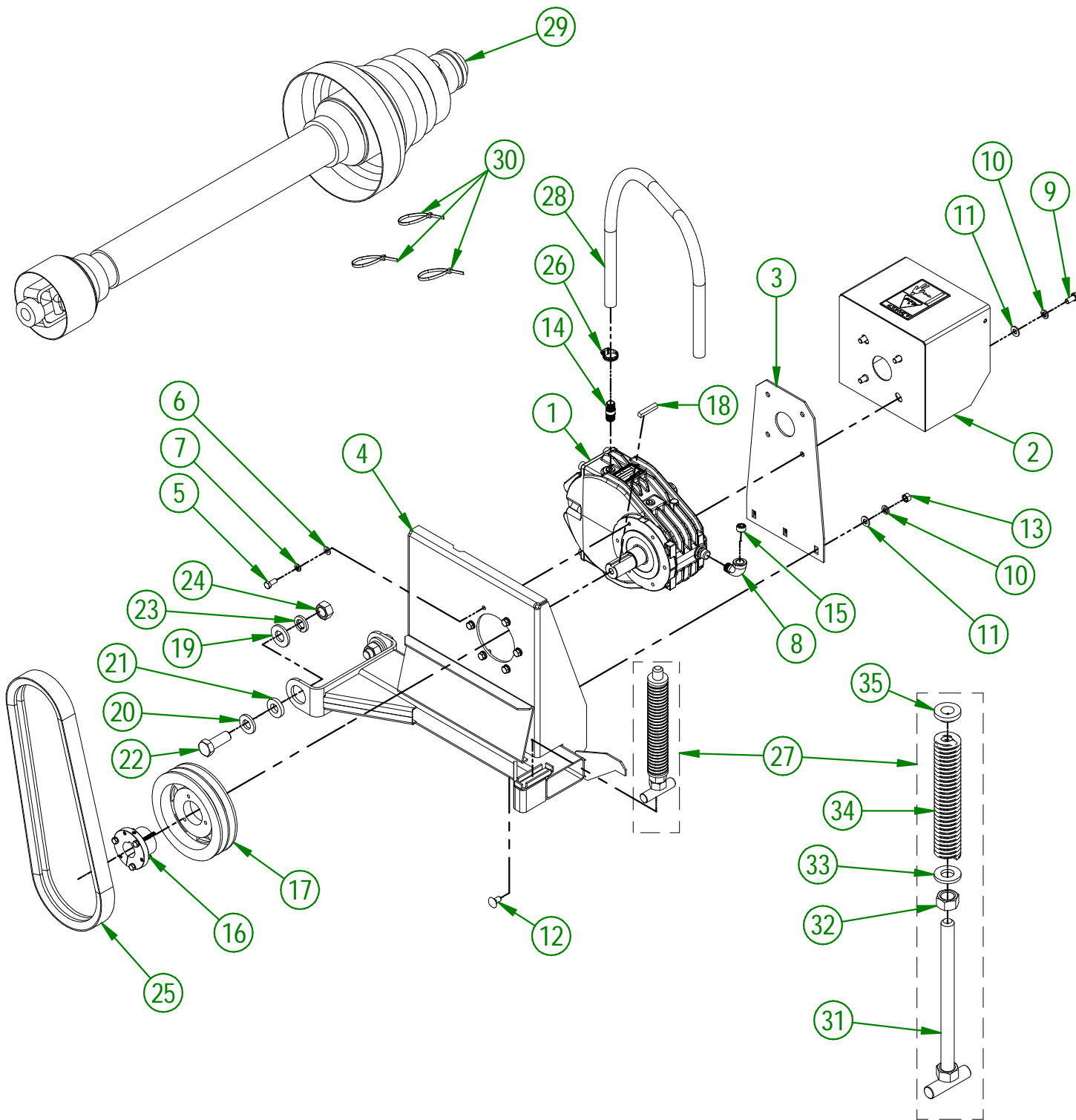

USE THESE PIECES ONLY IF YOUR SERIAL NUMBER IS AFFECTED:

42089 & ABOVE

AGRIMETAL	
TRANSMISSION BASE MOUNT GROUP	
CREATION : 14/10/21	ASSEMBLY : 22-57-0079
REVISION : 15/12/25	AUTHOR : F.HÉLIE

22-57-0079

#	PART #	Qty	TITLE
1	22-34-0100	1	A624A RATIO 1:5 15 TRANSMISSION
2	01-57-0535	1	PTO GUARD "STICKER INCLUDED"
3	22-01-0970	1	TRANSMISSION SUPPORT
4	22-50-0086	1	TRANSMISSION BASE MOUNT
5	NC01-45-0184	6	HEX. BOLT GR8.8 ZINC 8MM X 20MM
6	NC02-22-0008	6	WASHER ZINC 5/16"
7	NC02-32-0011	6	LOCK WASHER ZINC 5/16"
8	NC13-65-0003	1	BRASS ELBOW 90 3/8 FEM. NPT X 3/8 MALE NPT
9	NC01-17-0112	4	HEX. BOLT GR2 ZINC 3/8-16 X 3/4"
10	NC02-32-0012	7	LOCK WASHER ZINC 3/8"
11	01-01-2485	7	FLAT WASHER 14 GA X 13/16"OD X 25/64" ID
12	NC01-04-0107	3	CARR. BOLT GR2 ZINC 3/8-16 X 3/4"
13	NC02-07-0018	3	HEX. NUT ZINC 3/8-16
14	NC13-65-0010	1	BRASS NIPPLE 3/8" X 1 1/2" LG.
15	NC02-44-0204	1	SET SCREW NPTF 3/8-18
16	16-39-0435	1	TAPERED QD BUSHING SDS X 1 1/4" K.W. 5/16"
17	NC14-62-0231	1	PULLEY QD 2VI/2-5/8 X 7.125 OD X SDS 2B68
18	06-41-0900	1	SQUARE KEY 5/16" X 5/16" X 1 3/4" LG.
19	09-04-0050	2	PNO 3/16" X 1 49/64" DIA. X \emptyset 7/8" FLAT WASHER
20	22-04-6805	2	FLAT WASHER BEARING BASE
21	22-13-0005	2	BUSHING
22	NC01-17-0467	2	HEX. BOLT GR2 ZINC 3/4-10 X 2"
23	NC02-32-0017	2	LOCK WASHER ZINC 3/4"
24	NC02-07-0023	2	HEX. NUT ZINC 3/4-10
25	NC14-25-2560	1	HI-POWER V BELT 2RB-46
26	NC01-65-0055	1	HOSE CLAMP COLLAR
27	22-55-0065	1	BELT TENSION KIT ASS'Y
28	16-46-0525	1	OVER FLOW TRANSMISSION HOSE 39" LG.
29	28-34-0030	1	PTO SHAFT T60 X 45.98"
30	NC13-25-0229	3	BLACK TIE RAP

22-55-0065

#	PART #	Qty	TITLE
31	22-50-0200	1	WELD ASSEMBLY TENSIONER PIVOT
32	NC02-07-0023	1	HEX. NUT ZINC 3/4-10
33	22-04-6805	1	FLAT WASHER BEARING BASE
34	NC13-86-0083	1	BLUE SPRING 1/2" ID X 1" OD X 8"
35	22-42-0125	1	TENSIONER GUIDE

#AGRIMETAL : 28-34-0030

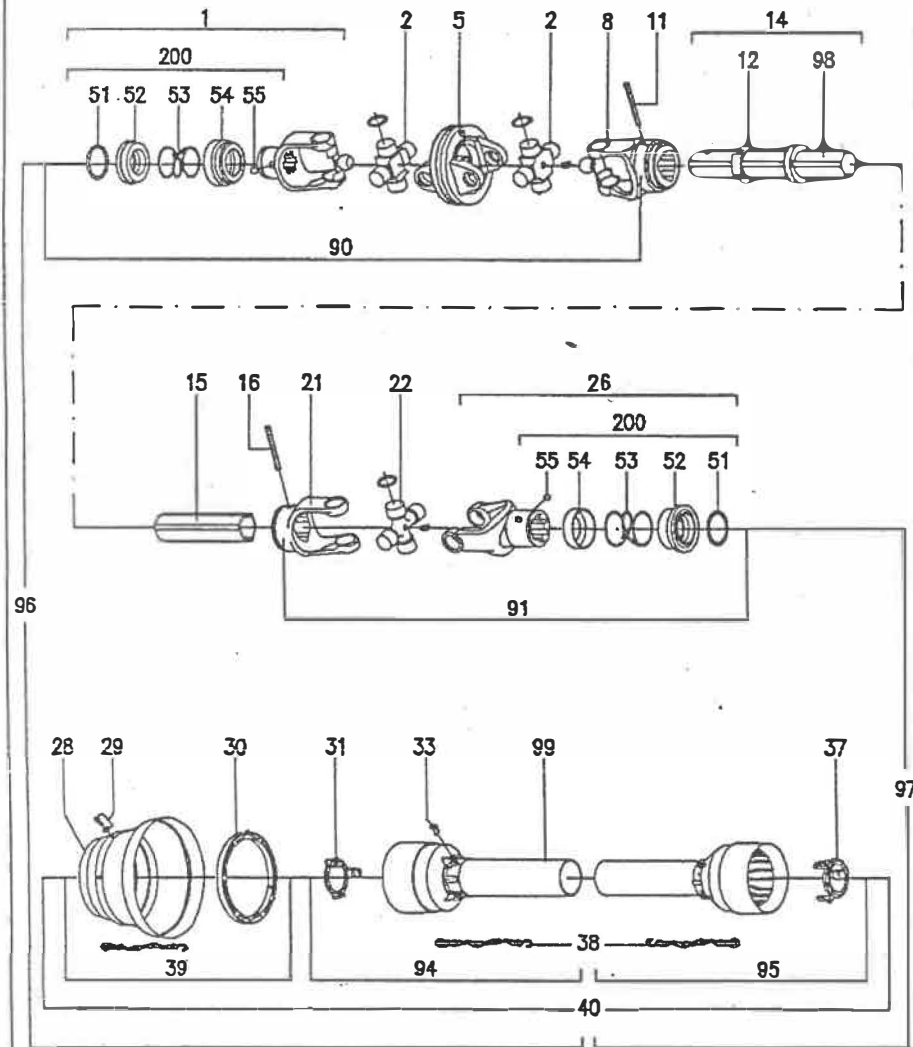

Pos.	Description	Q.ty	Code	Pos.
1	Complete collar yoke-C02- for CV-joint 1 3/8" Z6	1	141.026.503	1.
2	Cross journal set for CV-joint $\varnothing 30.2 \times 101.4$	2	180.016.228	2
5	Wide angle double yoke	1	141.026.224	5
8	Outer yoke for CV-joint	1	141.026.229	8
11	Roll pin for outer tube	1	190.000.018	11
12	Bush with grease fitting	1	180.016.316	12
14	Complete outer tube L=0650	1	152.160.579.7820	14
15	Inner tube L=0665	1	159.160.840	15
16	Roll pin for inner tube	1	190.000.016	16
21	Inner yoke	1	151.016.029	21
22	Cross journal set $\varnothing 30.2 \times 92$	1	180.016.004	22
26	Complete collar yoke C12 1 3/8" Z6	1	141.026.544	26
28	Guard cone for wide angle CV-joint	1	180.016.244	28
29	Screw	6	190.000.296	29
30	Bearing ring	1	180.016.245	30
31	Guard retaining collar for outer tube	1	180.016.016	31
33	Bolt	6	190.000.019	33
37	Guard retaining collar for inner tube	1	180.016.015	37
38	Safety chains	3	180.016.025	38
39	Guard cone set	1	165.000.570	39
40	Complete guard with Instruction Manual	1	142.761.039.3620	40
51	Outer circlip	2	190.000.451	51
52	Sliding sleeve collar	2	151.016.486	52
53	Spring	2	180.016.487	53
54	Fixed sleeve collar	2	180.016.483	54
55	Ball $\varnothing 1/2"$	6	190.000.078	55
90	Wide angle CV-joint for outer tube	1	121.026.658.00	90
91	U Joint for inner tube	1	121.026.900.00	91
94	Hoff female guard	1	142.261.032.3620	94
95	Half male guard	1	142.261.329.3620	95
96	Half female shaft with guarding	1	179610810FD2502	96
97	Half male shaft with guarding	1	123.460.996.00	97
98	"DANGER" Label for outer tube	1	190.000.216	98
99	"DANGER" Label for outer guard tube	1	190.000.215	99
100	Instruction manual	1	190.000.371	100
200	Kit collar 1 3/8"	2	165.000.628	200

#AGRIMETAL: 01-34-0101

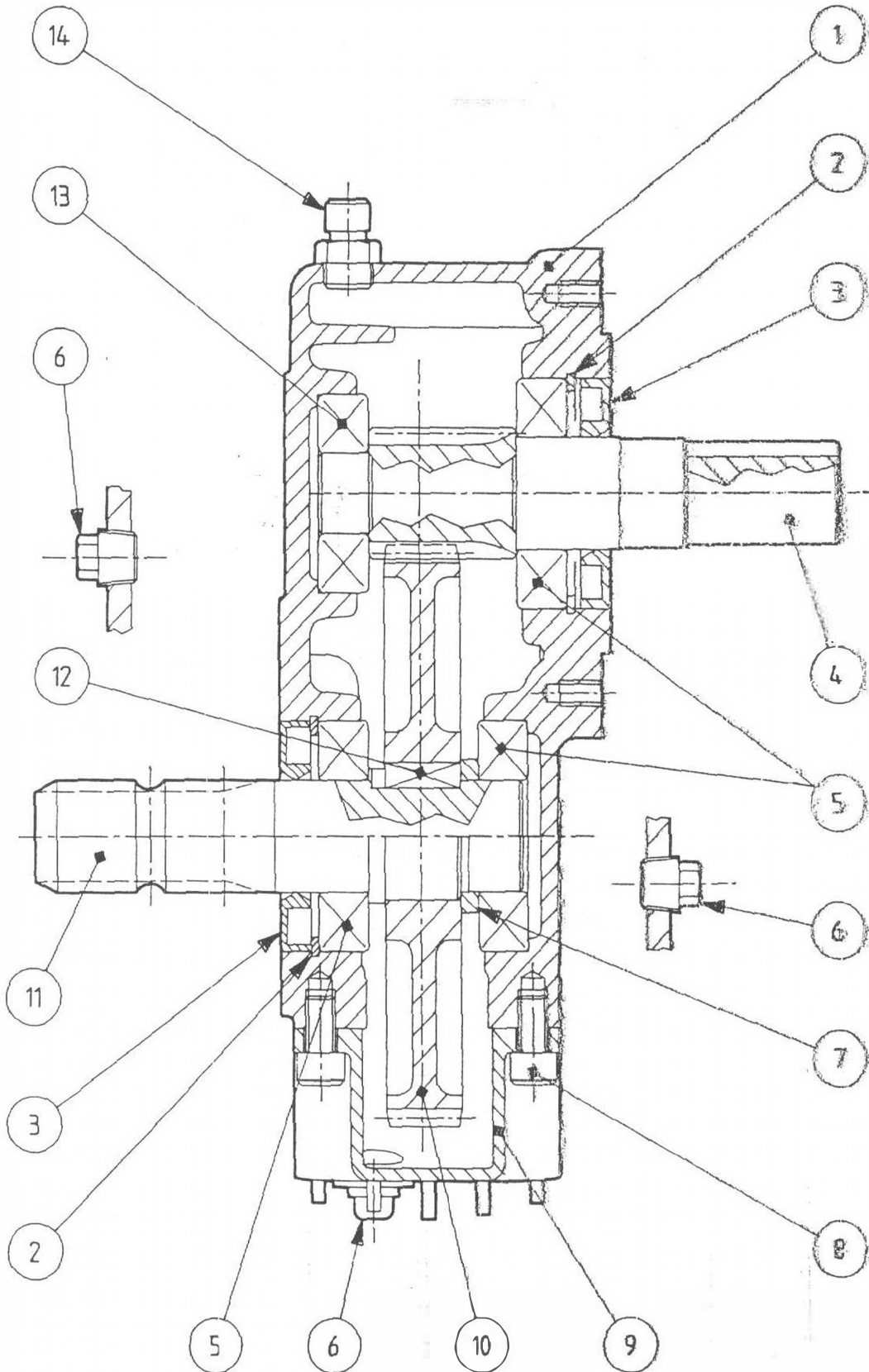

POS.	DRG. N.	PIEC	DESCRIPTION
1	0.624.0300.00	1	CASING
2	8.5.2.00131	2	SNAP RING 72 UNI7437
3	8.7.3.00055	2	OIL SEAL 35X72X10
4	0.617.5301.00	1	FINION SHAFT Z13 M2.5
5	8.0.1.00025	3	BEARING 6207
6	8.6.6.00201	3	PLUG 3/8"GAS
7	0.617.7100.00	1	SPACER
8	8.1.2.00672	6	BOLT M10X18 8,8
9	0.624.1300.00	1	COVER
10	0.617.5300.00	1	GEAR Z67
11	0.617.2000.00	1	SHAFT
12	8.4.1.00312	1	PARALLEL KEY A 12X8X30
13	8.0.1.00001	1	BEARING 6305
14	8.6.7.00161	1	OIL FILLER PLUG 3/8G

#	PART #	Qty	TITLE
1	22-57-0247	1	PTO BELT GUARD "STICKER INCLUDED"
2	NC01-04-0107	2	CARR. BOLT GR2 ZINC 3/8-16 X 3/4"
3	NC02-07-0018	2	HEX. NUT ZINC 3/8-16
4	NC02-32-0012	2	LOCK WASHER ZINC 3/8"
5	01-01-2485	2	FLAT WASHER

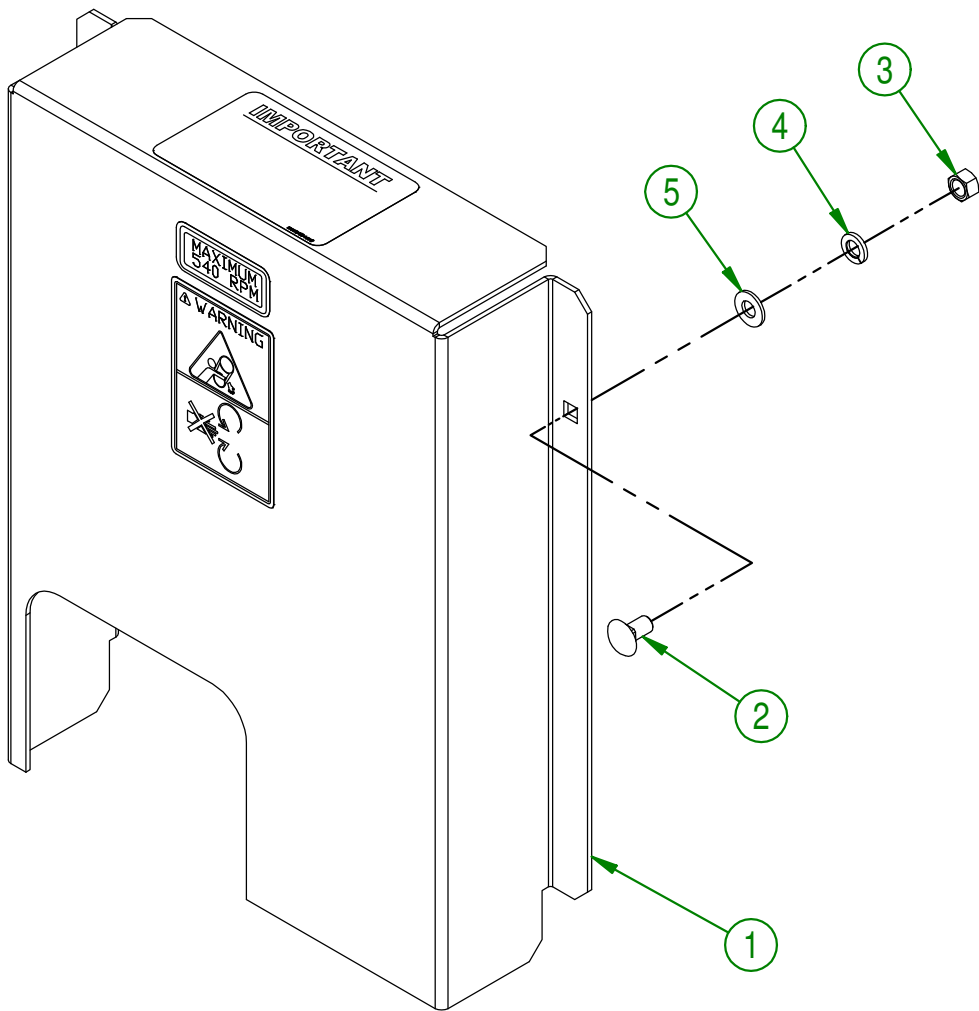

AGRIMETAL	
PTO BELT GUARD GROUP	
CREATION : 17/04/18	ASSEMBLY : 22-57-0192
REVISION : 17/04/18	AUTHOR : F.HÉLIE Page 9 de 67

#	PART #	Qty	TITLE
1	NC01-04-0107	16	CARR. BOLT GR2 ZINC 3/8-16 X 3/4"
2	01-01-2485	16	FLAT WASHER
3	NC02-32-0012	16	LOCK WASHER ZINC 3/8"
4	NC02-07-0018	16	HEX. NUT ZINC 3/8-16

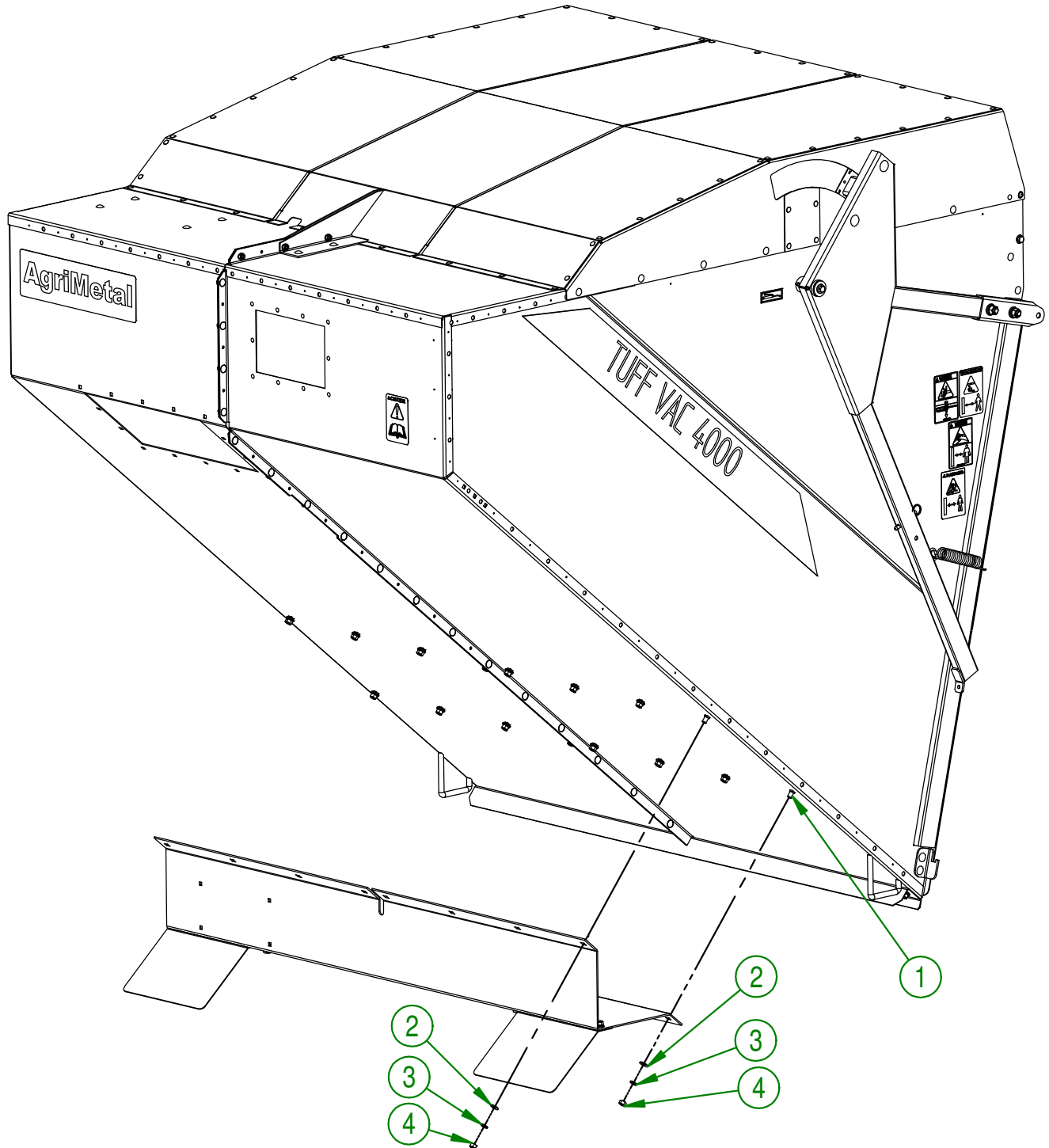

AGRIMETAL	
ASSEMBLY MAIN BOX	
CREATION : 17/04/18	ASSEMBLY : 22-57-0538
REVISION : 04/05/18	AUTHOR : F.HÉLIE Page 10 de 67

#	PART #	Qty	TITLE
1	22-01-1000	1	BOX SUPPORT
2	NC01-17-0248	4	HEX. BOLT GR2 ZINC 1/2-13 X 1 1/4"
3	01-01-0925	8	WASHER
4	NC02-32-0014	4	LOCK WASHER ZINC 1/2"
5	NC02-07-0020	4	HEX. NUT ZINC 1/2-13
6	22-01-2415	2	WHEEL FENDER
7	NC01-04-0107	6	CARR. BOLT GR2 ZINC 3/8-16 X 3/4"
8	01-01-2485	6	FLAT WASHER
9	NC02-32-0012	6	LOCK WASHER ZINC 3/8"
10	NC02-07-0018	6	HEX. NUT ZINC 3/8-16

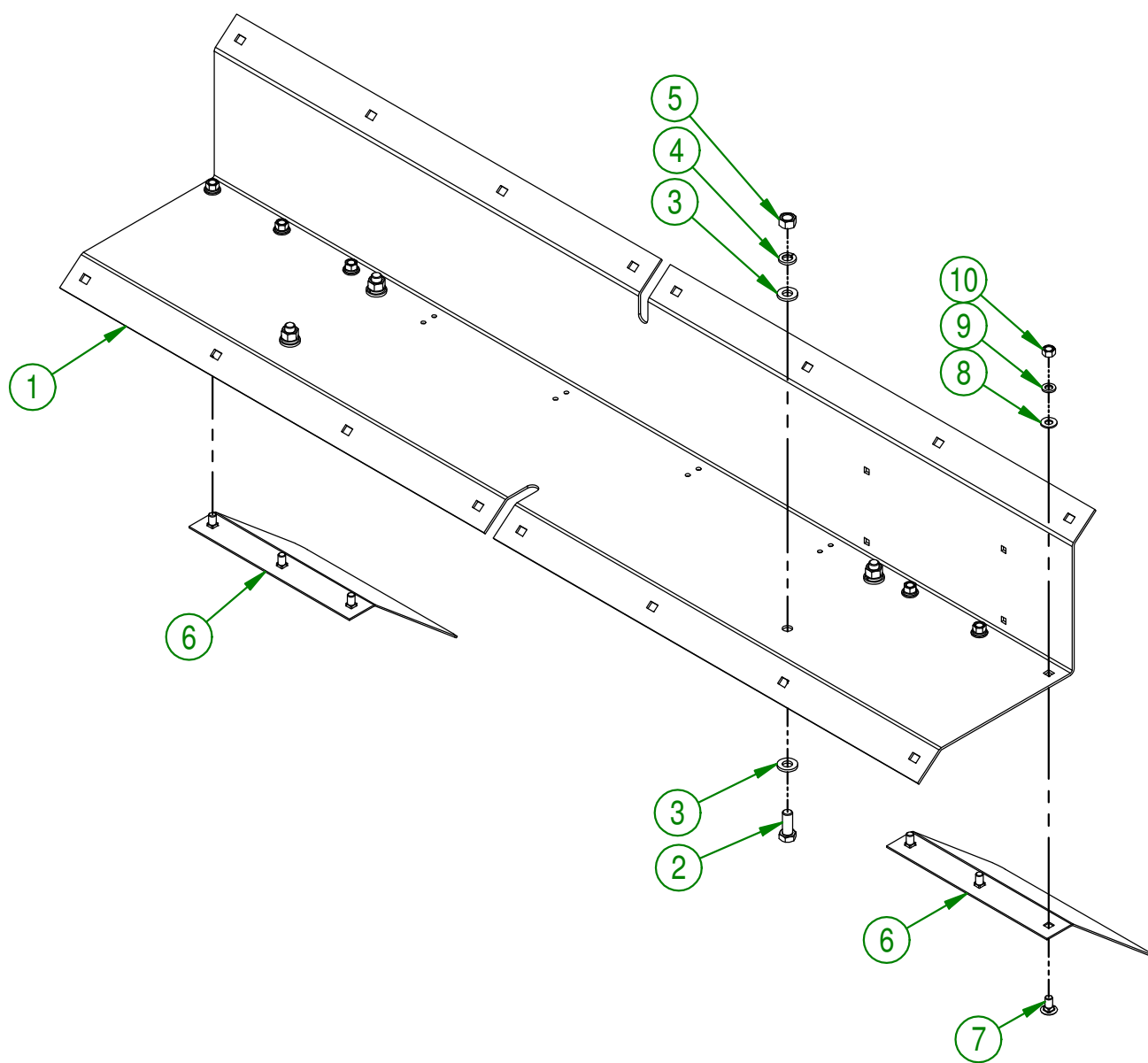

AGRIMETAL		
ASSEMBLY FENDER		
CREATION : 2016-10-19	ASSEMBLY :	22-57-0065
REVISION : 2018-05-04	AUTHOR : S.B.	Page 11 de 67

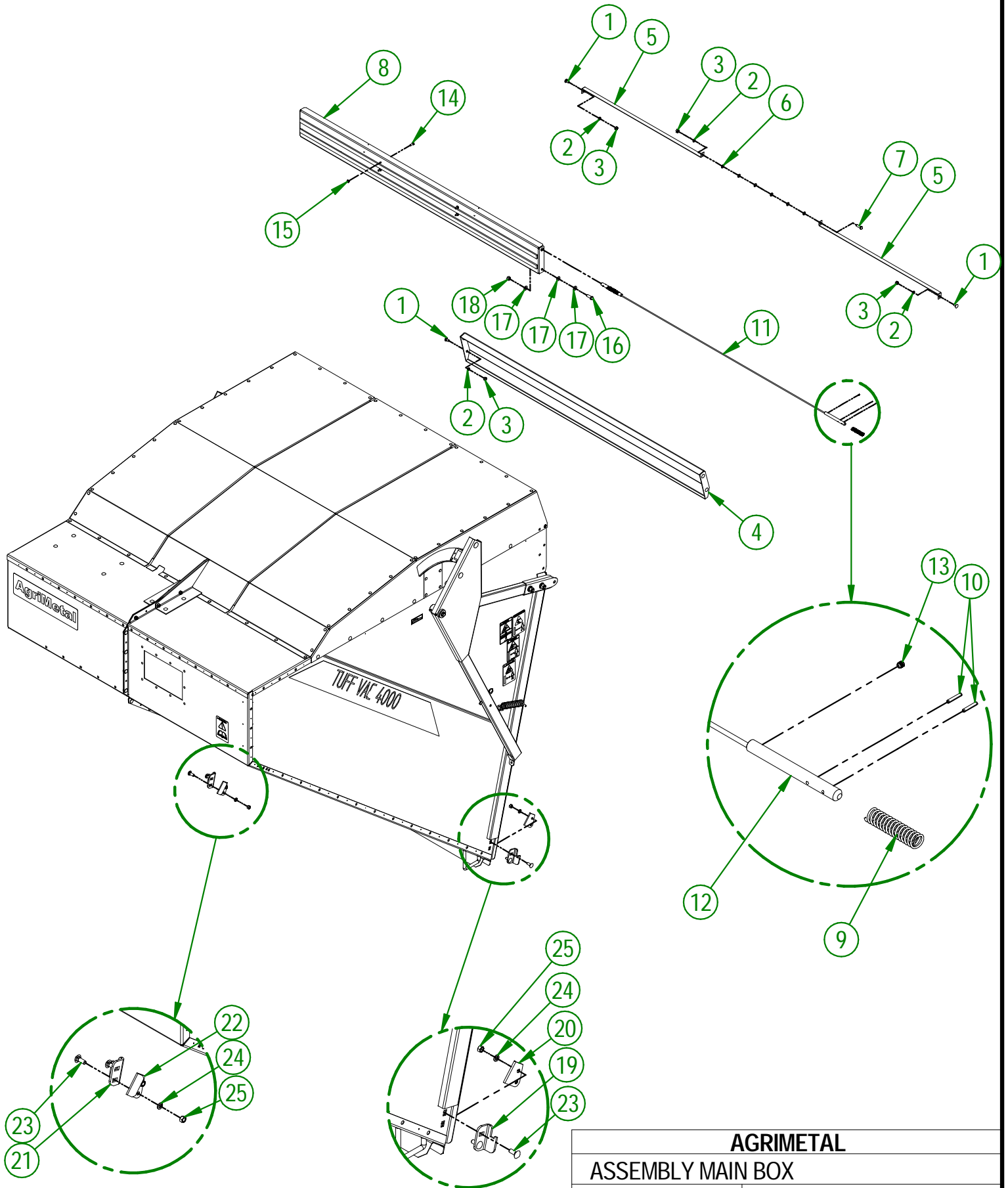

AGRIMETAL		
ASSEMBLY MAIN BOX		
CREATION : 2018-04-17	ASSEMBLY :	22-55-0576
REVISION : 2023-02-09	AUTHOR :	

#	PART #	Qty	TITLE
1	NC01-04-0055	6	CARR. BOLT GR2 ZINC 5/16-18 X 5/8"
2	NC02-32-0011	7	LOCK WASHER ZINC 5/16"
3	NC02-07-0017	7	HEX. NUT 5/16-18
4	22-57-0660	1	CHANNEL CROSS MEMBER BOX GROUP
5	22-01-3110	2	FILTER RETAINER
6	NC02-22-0008	6	WASHER ZINC 5/16"
7	NC01-17-0060	1	HEX. BOLT GR2 ZINC 5/16-18 X 1"
8	22-57-0655	1	FILTER DOOR
9	NC13-85-0025	2	COMPRESSION SPRING
10	NC01-69-0377	4	CUTTER PIN ZINC 1/8" X 3/4"
11	22-41-0050	1	GRILL DOOR CABLE
12	22-20-0260	2	GRILL DOOR LOCK
13	NC02-44-0088	2	ALLENS SET SCREW 1/4-20 X 1/4" LG.
14	NC01-29-0003	4	HEX. BOLT GR5 ZINC 1/4-28 X 5/8"
15	NC02-14-0200	4	HEX. LOCK NUT THIN 1/4-20
16	NC01-17-0114	2	HEX. BOLT GR2 ZINC 3/8-16 X 1"
17	01-01-2485	6	FLAT WASHER 14 GA X 13/16"OD X 25/64" ID
18	NC01-96-0011	2	NYLON NUT 3/8-16
19	22-04-6820	1	LEFT DOOR LATCH
20	22-01-3085	1	LEFT DOOR LATCH DEFLECTOR
21	22-04-0040	1	RIGHT DOOR LATCH
22	22-01-3080	1	RIGHT DOOR LATCH DEFLECTOR
23	NC01-04-0109	4	CARR. BOLT GR2 ZINC 3/8-16 X 1"
24	NC02-32-0012	4	LOCK WASHER ZINC 3/8"
25	NC02-07-0018	4	HEX. NUT ZINC 3/8-16

AGRIMETAL	
ASSEMBLY MAIN BOX	
CREATION : 2018-04-17	ASSEMBLY : 22-55-0576
REVISION : 2023-02-09	AUTHOR :

22-55-0576

#	PART #	Qty	TITLE
1	NC01-04-0055	6	CARR. BOLT GR2 ZINC 5/16-18 X 5/8"
2	NC02-32-0011	7	LOCK WASHER ZINC 5/16"
3	NC02-07-0017	7	HEX. NUT 5/16-18
4	22-57-0660	1	CHANNEL CROSS MEMBER BOX GROUP
5	22-01-3110	2	FILTER RETAINER
6	NC02-22-0008	6	WASHER ZINC 5/16"
7	NC01-17-0060	1	BOLT HEX. GR2 ZINC 5/16-18 X 1"
8	22-57-0655	1	FILTER DOOR
9	NC13-85-0025	2	COMPRESSION SPRING
10	NC01-69-0377	4	CUTTER PIN ZINC 1/8" X 3/4"
11	22-41-0050	1	FILTER DOOR CABLE
12	22-13-0600	2	FILTER DOOR LOCK
13	NC02-44-0088	2	ALLENS SET SCREW 1/4-20 X 1/4" LG.
14	NC01-29-0003	4	HEX. BOLT GR5 ZINC 1/4-28 X 5/8"
15	NC02-14-0200	4	HEX. LOCK NUT THIN 1/4-20
16	NC01-17-0114	2	HEX. BOLT GR2 ZINC 3/8-16 X 1"
17	01-01-2485	6	FLAT WASHER
18	NC01-96-0011	2	NYLON NUT 3/8-16
19	22-04-6820	1	LEFT DOOR LATCH
20	22-01-3085	1	LEFT DOOR LATCH DEFLECTOR
21	22-04-0040	1	RIGHT DOOR LATCH
22	22-01-3080	1	RIGHT DOOR LATCH DEFLECTOR
23	NC01-04-0109	4	CARR. BOLT GR2 ZINC 3/8-16 X 1"
24	NC02-32-0012	4	LOCK WASHER ZINC 3/8"
25	NC02-07-0018	4	HEX. NUT ZINC 3/8-16

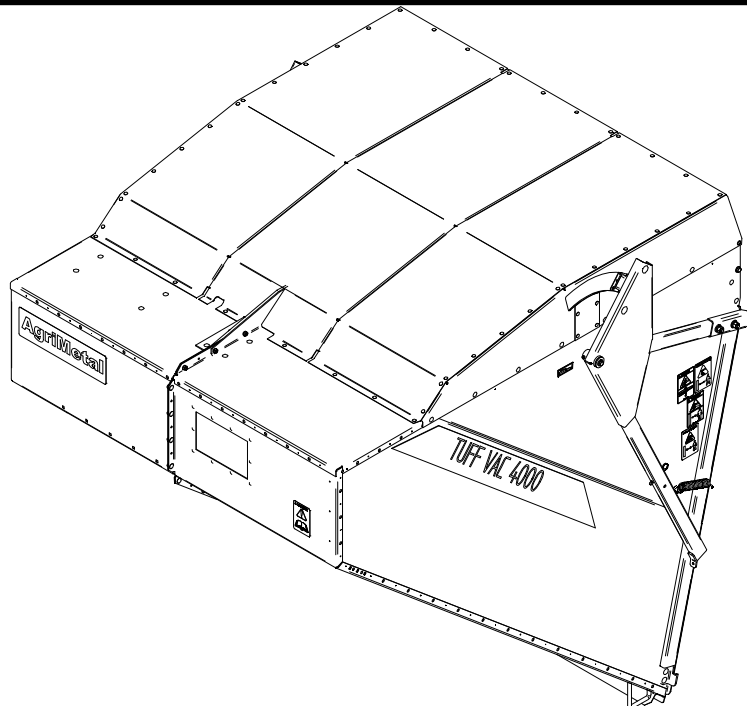
**AGRIMETAL****ASSEMBLY MAIN BOX**

CREATION : 2018-04-17	ASSEMBLY :	22-55-0576
REVISION : 2018-05-04	AUTHOR :	Page 13 de 67

#	PART #	Qty	TITLE
1	22-55-0195	1	CYLINDER
2	22-13-1420	1	CYLINDER PIN
3	22-13-1415	1	CYLINDER PIN
4	NC01-17-0114	4	HEX. BOLT GR2 ZINC 3/8-16 X 1"
5	04-33-0225	4	FLAT WASHER 1 1/2" DIA. X 1"
6	04-33-0220	2	FLAT WASHER 1 1/2" DIA. X 1"
7	NC02-32-0012	4	LOCK WASHER ZINC 3/8"
8	01-33-0010	4	WASHER
9	NC13-45-0391	2	STRAIGHT UNION

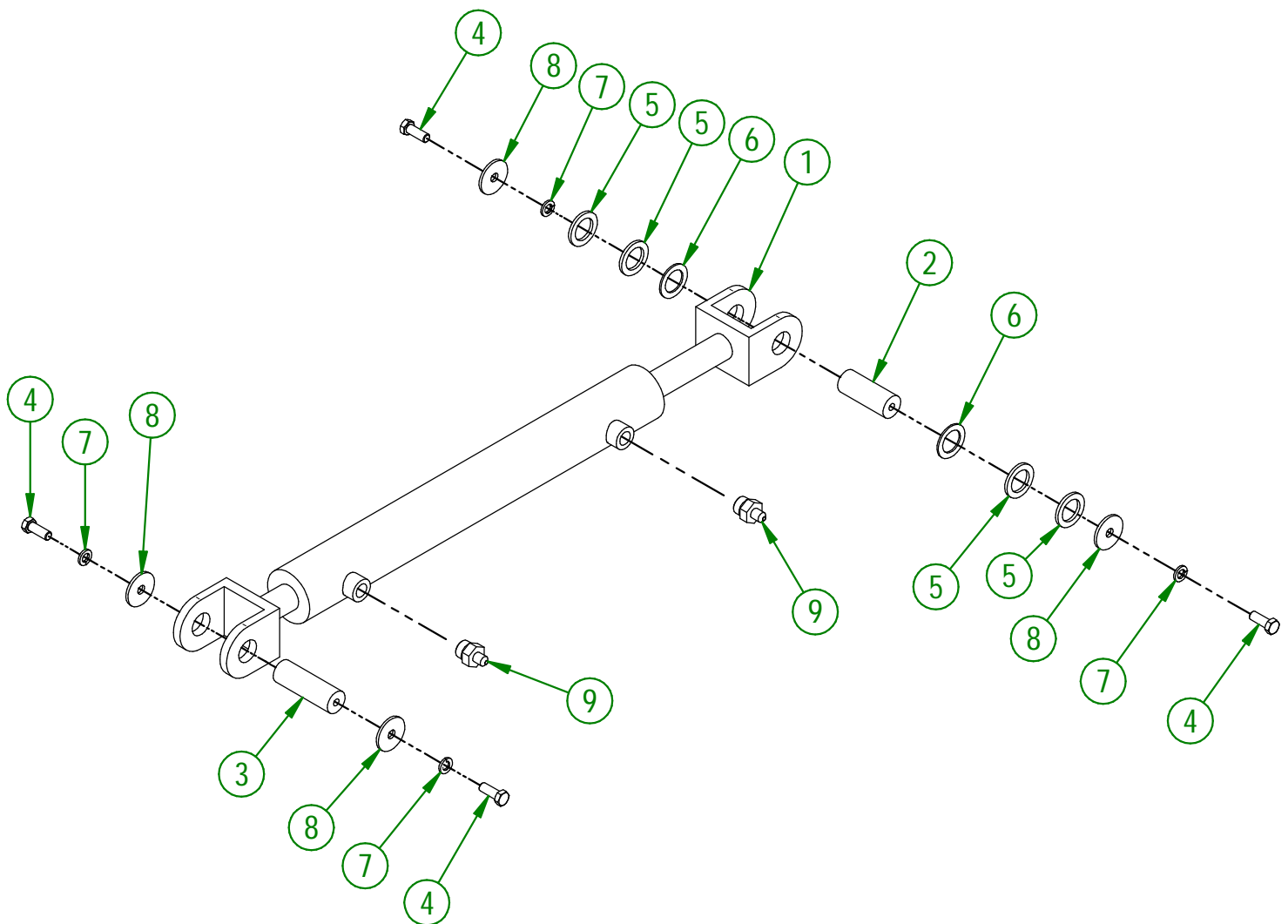

AGRIMETAL	
ASSEMBLY HYDRAULIC CYLINDER	
CREATION : 21/07/17	ASSEMBLY : 22-57-0225
REVISION : 24/04/23	AUTHOR : F.HÉLIE

#	PART #	Qty	TITLE
1	22-50-0120	1	CYLINDER ATTACHMENT
2	22-50-0140	1	ARM DOOR TRIANGLE (LEFT)
3	NC13-15-0051	4	O-RING
4	22-50-0145	1	ARM DOOR TRIANGLE (RIGHT)
5	NC01-04-0233	4	CARR. BOLT GR2 ZINC 1/2-13 X 1"
6	NC02-32-0014	10	LOCK WASHER ZINC 1/2"
7	NC02-07-0020	8	HEX. NUT ZINC 1/2-13
8	NC01-17-0114	2	HEX. BOLT GR2 ZINC 3/8-16 X 1"
9	01-33-0010	2	WASHER
10	NC01-69-0785	2	STRAIGHT GREASE FITTING 1/4-28
11	22-01-1170	2	DOOR SUPPORT
12	NC01-04-0237	4	CARR. BOLT GR2 ZINC 1/2-13 X 2"
13	NC02-25-0011	4	WASHER SAE ZINC 17/32 ID
14	NC13-85-0026	2	SPRING GALVANIZED 0.120"W X 1.050"OD X 6"
15	NC01-69-1201	1	SAFETY PIN

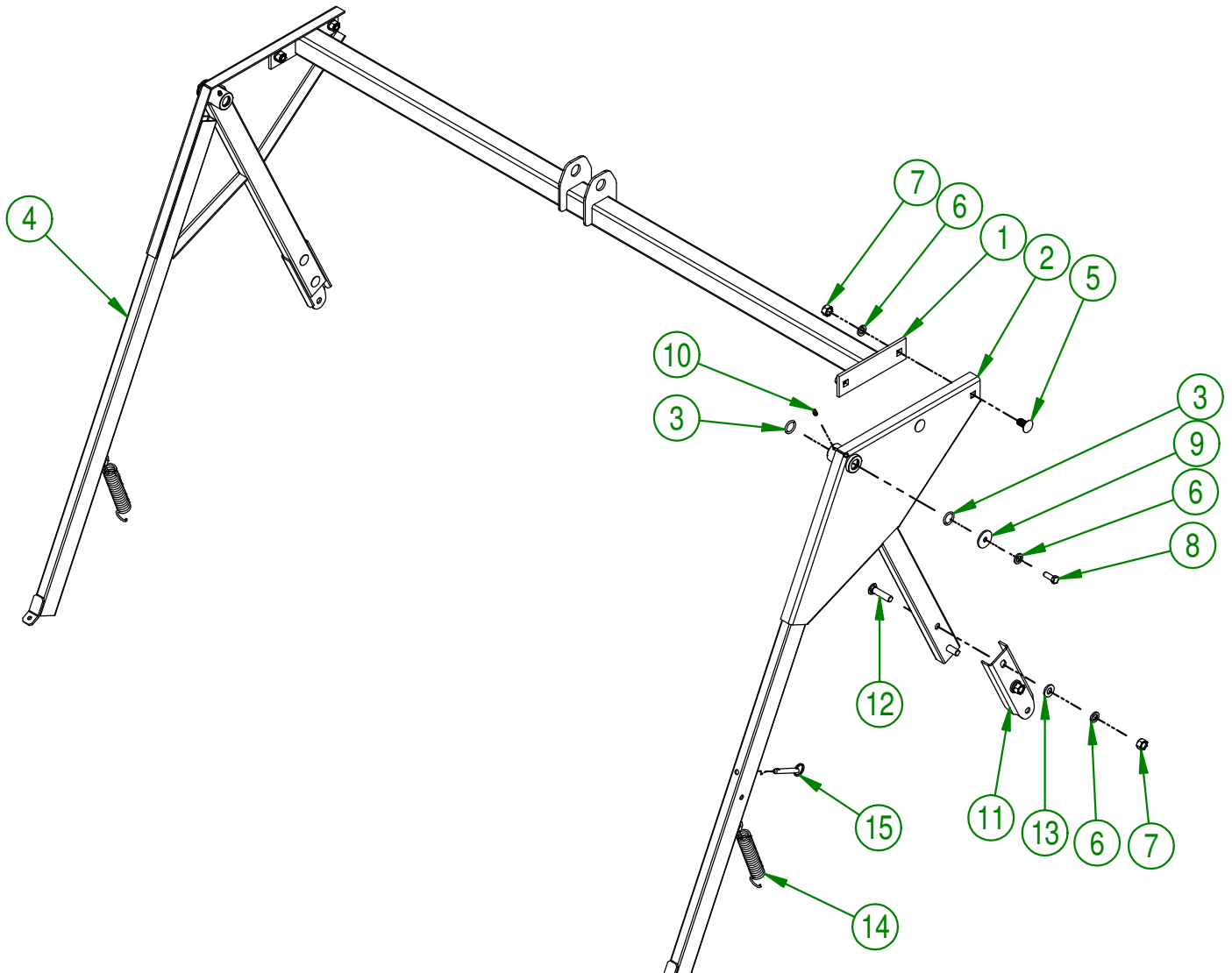

AGRIMETAL	
ASSEMBLY DOOR ARM TRIANGLE	
CREATION : 2016-10-13	ASSEMBLY : 22-57-0175
REVISION : 2018-05-04	AUTHOR : Page 15 de 67

#	PART #	Qty	TITLE
1	22-01-7665	1	SCREEN HOLDER
2	22-01-7670	1	SCREEN CHANNEL HOLDER (LARGE)
3	22-01-7660	1	SCREEN CHANNEL HOLDER (SMALL)
4	NC01-04-0116	2	CARR. BOLT GR2 ZINC 3/8-16 X 2 3/4"
5	NC02-32-0012	2	LOCK WASHER ZINC 3/8"
6	NC02-07-0018	2	HEX. NUT ZINC 3/8-16

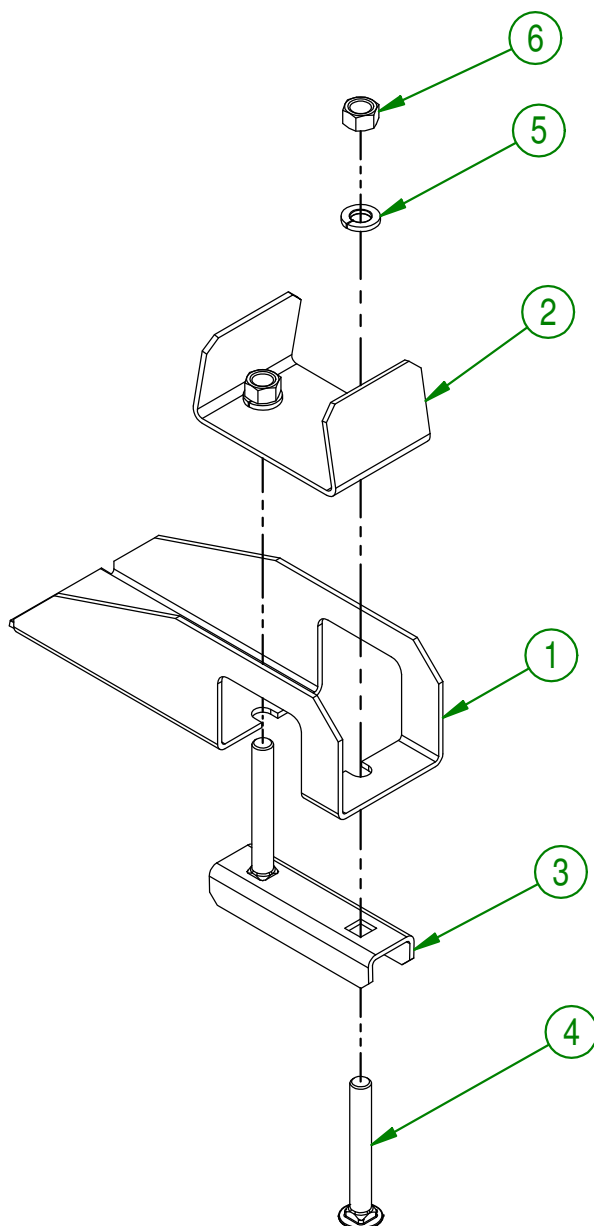

AGRIMETAL	
ASSEMBLY SCREEN HOLDER	
CREATION : 06/07/17	ASSEMBLY : 22-57-0235
REVISION : 04/05/18	AUTHOR : F.HÉLIE Page 16 de 67

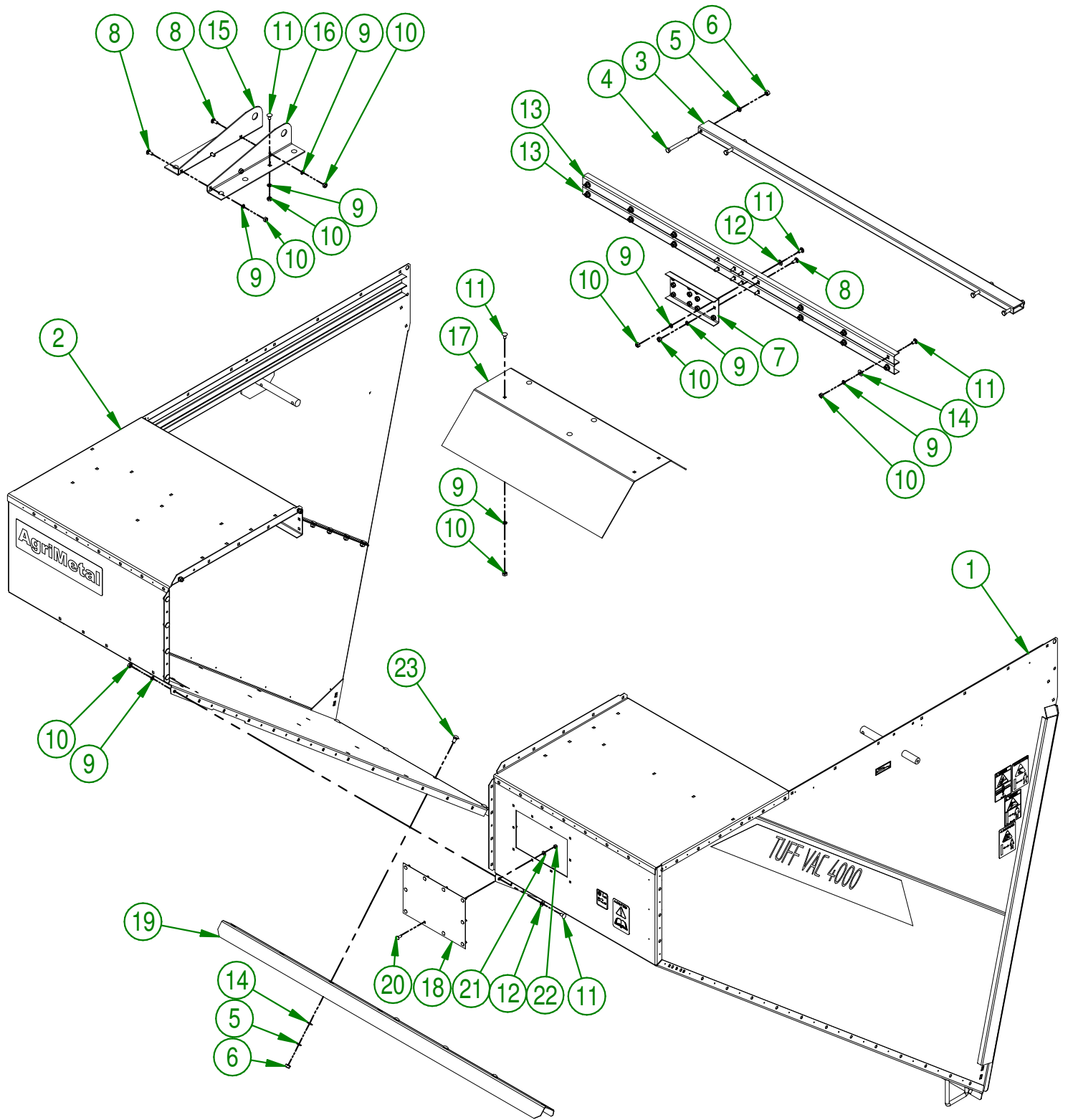

AGRIMETAL
ASSEMBLY SIDES BOX

CREATION : 17/04/18
 REVISION : 07/09/21

ASSEMBLY : **22-57-0601**
 AUTHOR : F.HÉLIE

#	PART #	Qty	TITLE
1	22-57-0666	1	LEFT BOX SIDE (GAZ) "STICKER INCLUDED"
2	22-57-0670	1	RIGHT BOX SIDE
3	22-08-3000	1	TUBE CROSS MEMBER
4	NC01-17-0124	4	HEX. BOLT GR2 ZINC 3/8-16 X 3 1/2"
5	NC02-32-0012	12	LOCK WASHER ZINC 3/8"
6	NC02-07-0018	12	HEX. NUT ZINC 3/8-16
7	22-01-2450	1	TOP BOX UNION PLATE
8	NC01-04-0056	13	CARR. BOLT 5/16-18 X3/4"
9	NC02-32-0011	58	LOCK WASHER ZINC 5/16"
10	NC02-07-0017	58	HEX. NUT 5/16-18
11	NC01-04-0055	45	CARR. BOLT GR2 ZINC 5/16-18 X 5/8"
12	22-22-2600	21	CARRIAGE BOLT SHIM (5/16")
13	22-01-2420	2	GRILL SUPPORT (FRONTAL)
14	01-01-2485	20	FLAT WASHER 14 GA X 13/16"OD X 25/64" ID
15	22-01-1080	1	RIGHT HYDRAULIC CYLINDER SUPPORT
16	22-01-1075	1	LEFT HYDRAULIC CYLINDER SUPPORT
17	22-01-7595	1	CHUTE DEFLECTOR
18	22-42-0000	1	CLEAR ACCESS DOOR
19	22-01-2495	1	CHANNEL CROSS MEMBER
20	NC01-04-0002	10	CARR. BOLT GR2 ZINC 1/4-20 X 5/8"
21	NC02-25-0007	10	WASHER ZINC 0.281 = 9/32
22	NC01-96-0009	10	NYLON-INSERT LOCKNUT ZINC 1/4-20
23	NC01-04-0107	8	CARR. BOLT GR2 ZINC 3/8-16 X 3/4"

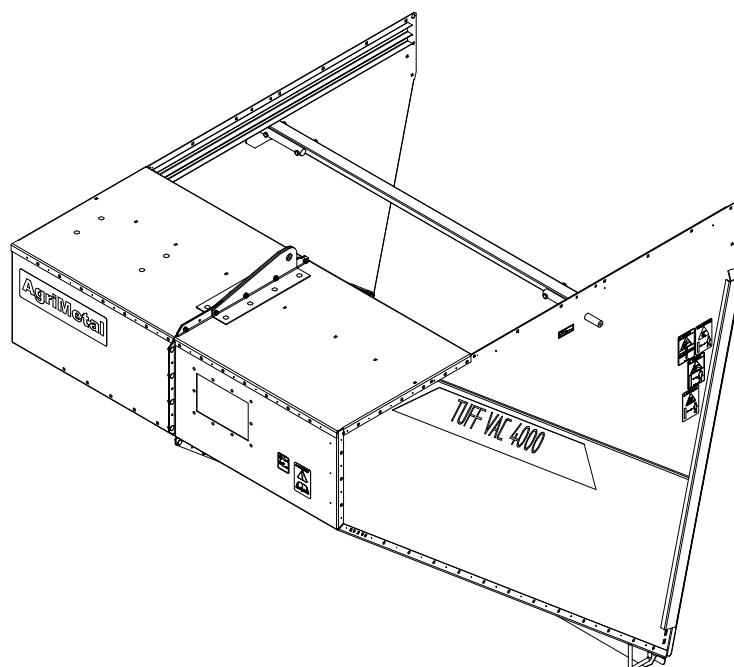

AGRIMETAL
ASSEMBLY SIDES BOX

CREATION : 17/04/18
REVISION : 07/09/21

ASSEMBLY : **22-57-0601**
AUTHOR : F.HÉLIE

#	PART #	Qty	TITLE
1	22-01-3045	2	DEFLECTOR DOOR
2	NC01-04-0002	16	CARR. BOLT GR2 ZINC 1/4-20 X 5/8"
3	NC01-96-0009	16	NYLON-INSERT LOCKNUT ZINC 1/4-20
4	22-01-2530	2	DEFLECTOR SIDE SHIM
5	NC01-04-0055	14	CARR. BOLT GR2 ZINC 5/16-18 X 5/8"
6	NC02-32-0011	14	LOCK WASHER ZINC 5/16"
7	NC02-07-0017	14	HEX. NUT 5/16-18
8	NC02-25-0007	12	WASHER ZINC 0.281 = 9/32

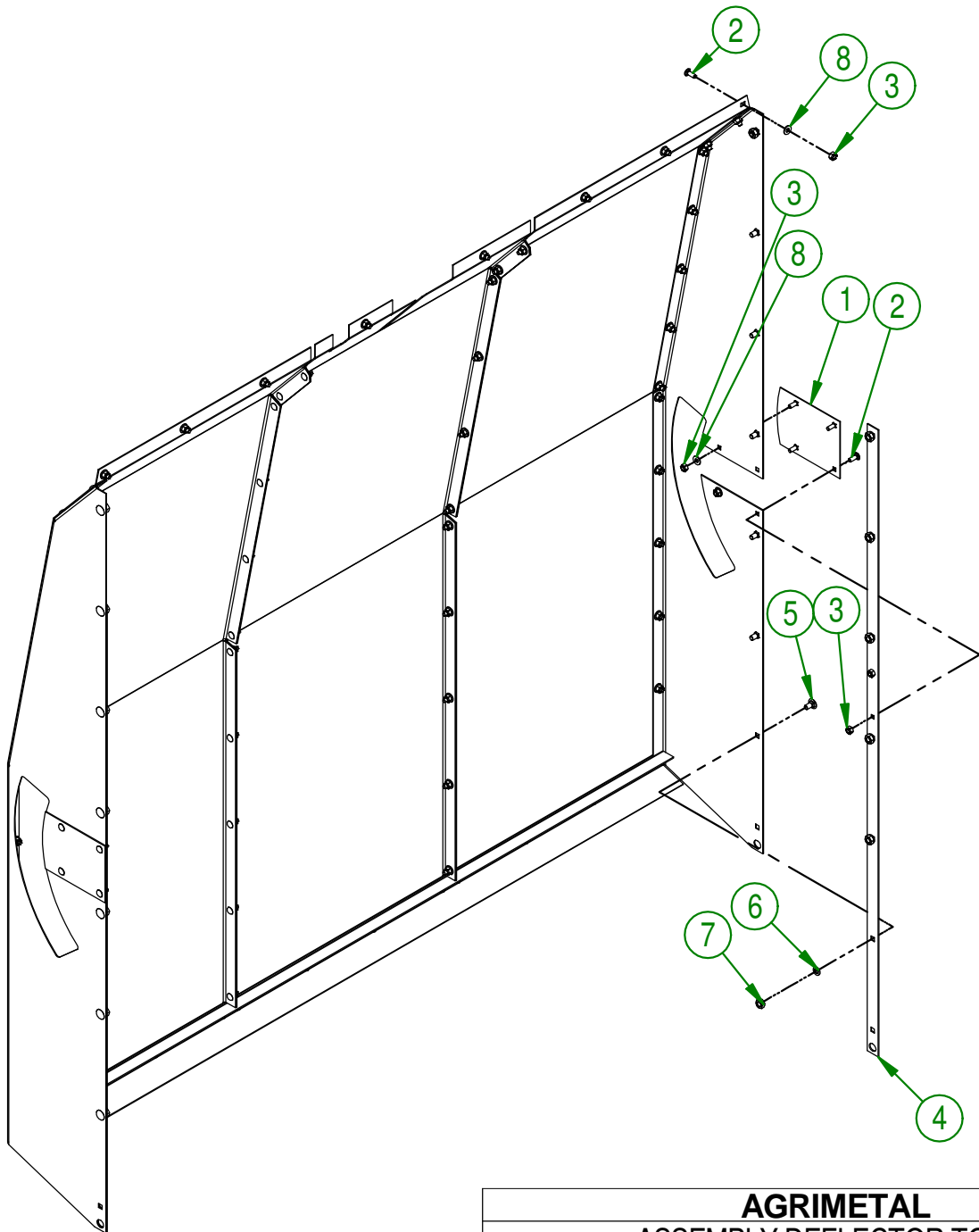

AGRIMETAL	
ASSEMBLY DEFLECTOR TOP	
CREATION : 12/07/17	ASSEMBLY : 22-57-0060
REVISION : 09/05/18	AUTHOR : F.HÉLIE Page 19 de 67

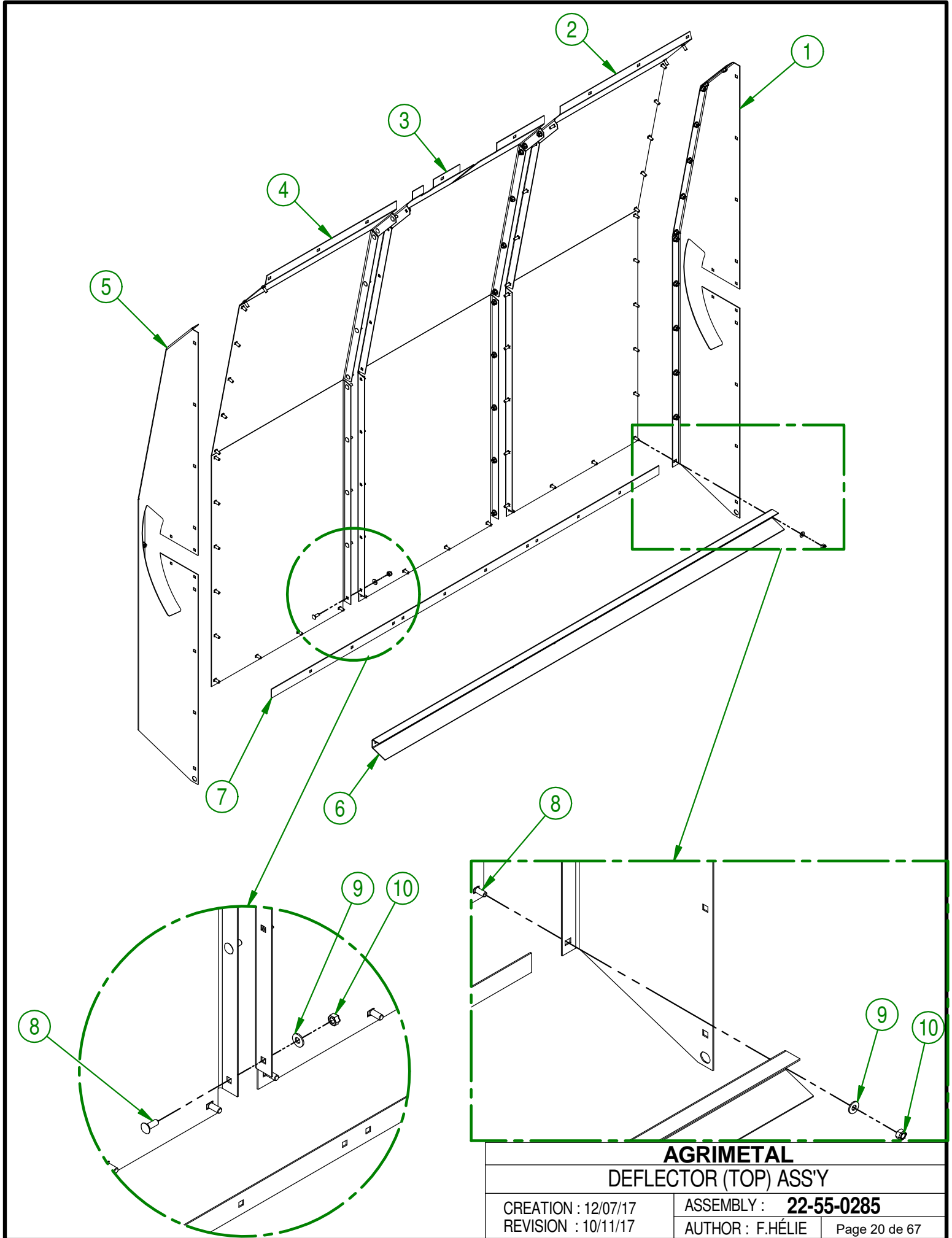

AGRIMETAL
DEFLECTOR (TOP) ASS'Y

CREATION : 12/07/17
 REVISION : 10/11/17

ASSEMBLY : **22-55-0285**

AUTHOR : F.HÉLIE

Page 20 de 67

#	PART #	Qty	TITLE
1	22-01-3030	1	LEFT DEFLECTOR SIDE
2	22-01-3040	1	LEFT DEFLECTOR TOP
3	22-01-3020	1	CENTRAL DEFLECTOR TOP
4	22-01-3025	1	RIGHT DEFLECTOR TOP
5	22-01-3035	1	RIGHT DEFLECTOR SIDE
6	22-01-2525	1	DEFLECTOR CHANNEL
7	22-01-3090	1	DEFLECTOR SHIM
8	NC01-04-0002	58	CARR. BOLT GR2 ZINC 1/4-20 X 5/8"
9	NC02-25-0007	58	WASHER ZINC 0.281 = 9/32
10	NC01-96-0009	58	NYLON-INSERT LOCKNUT ZINC 1/4-20

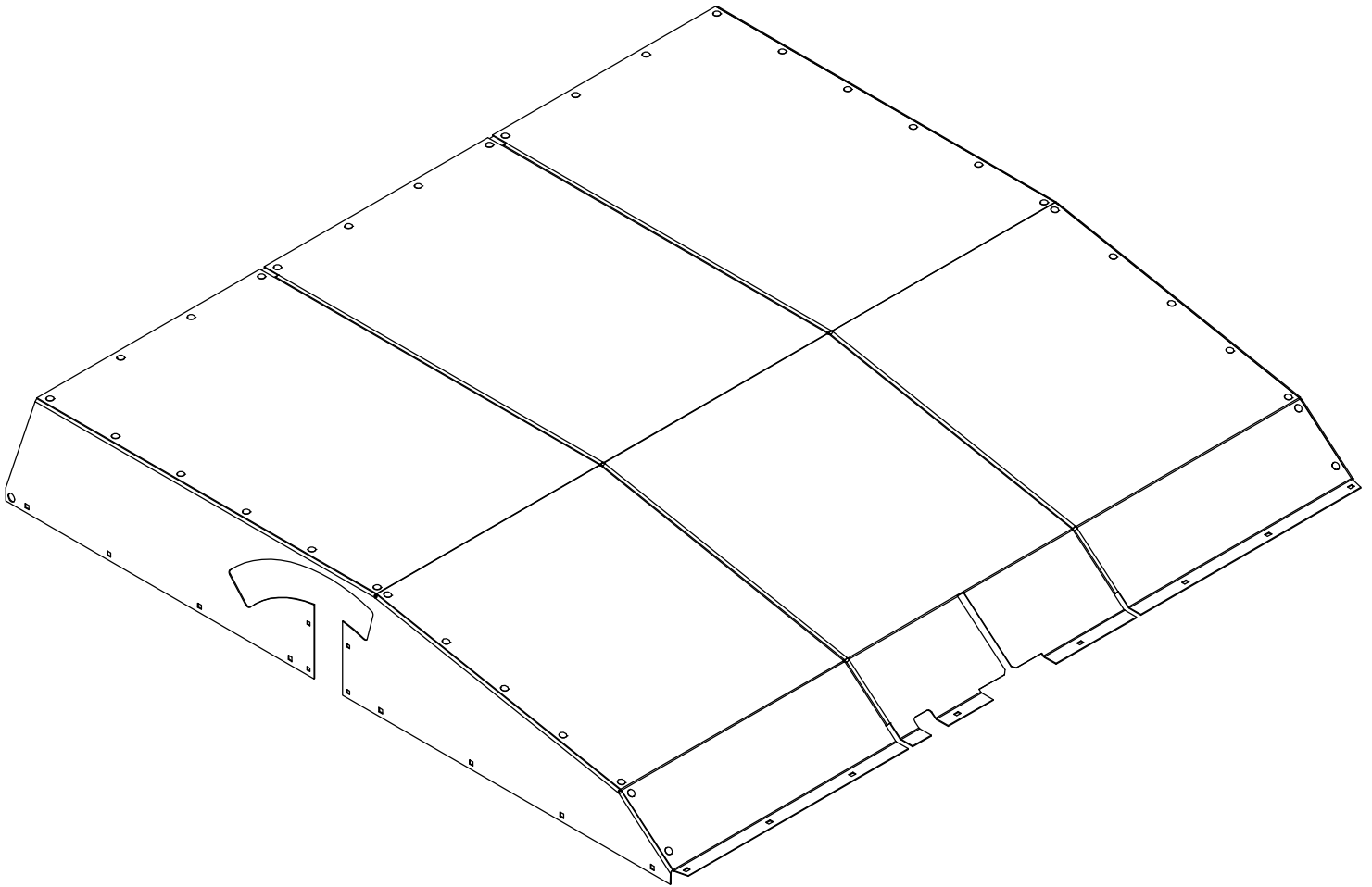

#	PART #	Qty	TITLE
1	22-55-0305	1	SEAL CONTENER (LEFT)
2	22-55-0315	1	SEAL CONTENER CLAMP
3	NC01-04-0014	2	BOLT CARR. GR2 ZINC 1/4-20 X 2 1/2"
4	NC01-96-0009	2	NYLON-INSERT LOCKNUT ZINC 1/4-20

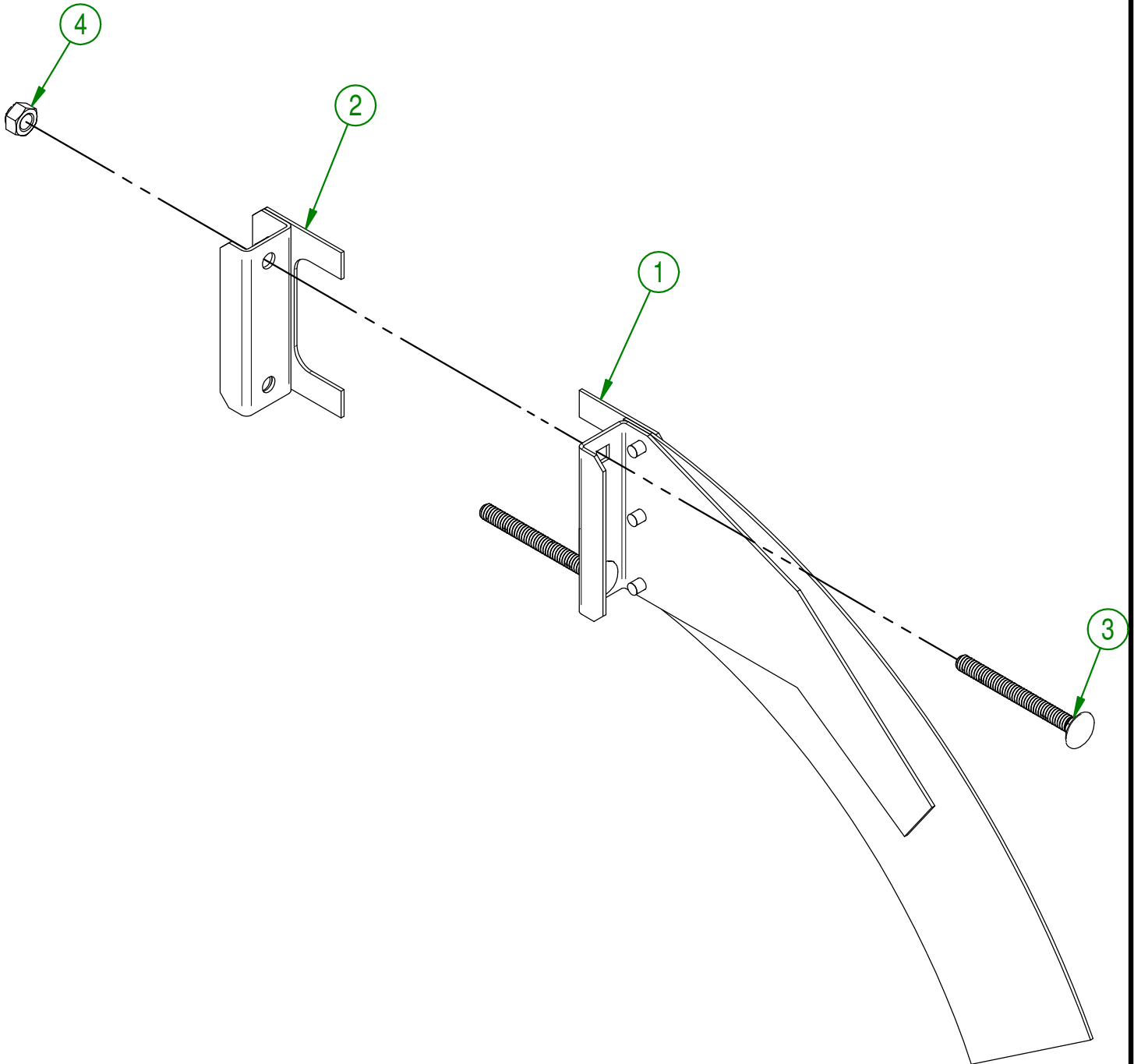

AGRIMETAL	
ASSEMBLY SEAL CONTENER LEFT	
CREATION : 08/08/17	ASSEMBLY : 22-57-0080
REVISION : 10/11/17	AUTHOR : F.HÉLIE Page 22 de 67

#	PART #	Qty	TITLE
1	22-55-0310	1	SEAL CONTENER (RIGHT)
2	22-55-0315	1	SEAL CONTENER CLAMP
3	NC01-04-0014	2	BOLT CARR. GR2 ZINC 1/4-20 X 2 1/2"
4	NC01-96-0009	2	NYLON-INSERT LOCKNUT ZINC 1/4-20

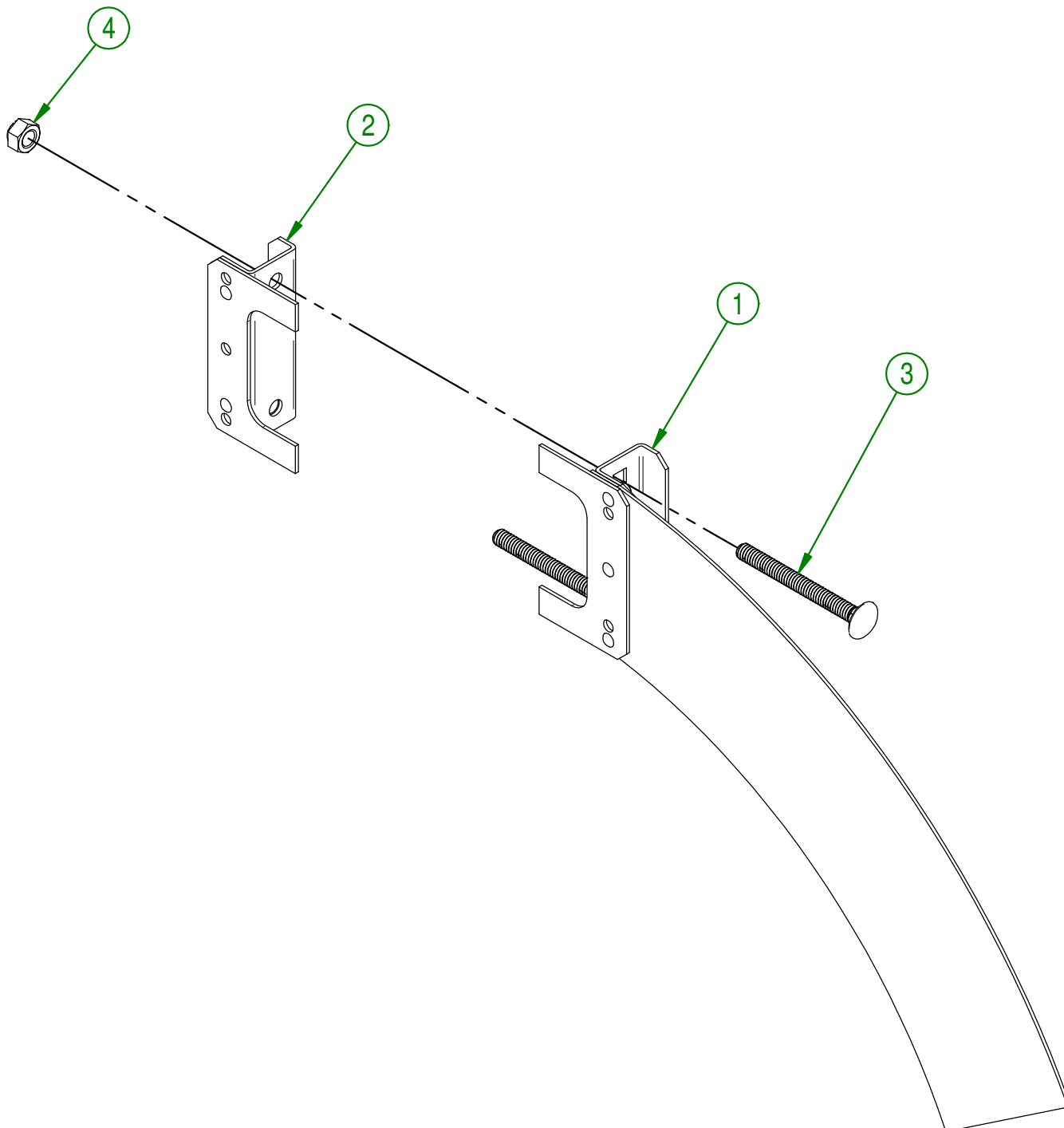

AGRIMETAL	
ASSEMBLY SEAL CONTENER RIGHT	
CREATION : 08/08/17	ASSEMBLY : 22-57-0085
REVISION : 10/11/17	AUTHOR : F.HÉLIE Page 23 de 67

#	PART #	Qty	TITLE
1	22-55-0006	1	ASSEMBLY VACUUM BLOWER (PTO)
2	NC01-04-0056	2	CARR. BOLT 5/16-18 X3/4"
3	NC02-07-0017	11	HEX. NUT 5/16-18
4	NC02-32-0011	11	LOCK WASHER ZINC 5/16"
5	NC01-04-0055	9	CARR. BOLT GR2 ZINC 5/16-18 X 5/8"
6	NC01-04-0107	2	CARR. BOLT GR2 ZINC 3/8-16 X 3/4"
7	NC02-32-0012	6	LOCK WASHER ZINC 3/8"
8	NC02-07-0018	6	HEX. NUT ZINC 3/8-16
9	01-01-2485	6	FLAT WASHER 14 GA X 13/16"OD X 25/64" ID
10	22-57-0310	1	FRONT SIDE DUCT GROUP
11	22-01-2515	1	ACCESS DOOR
12	NC14-62-0089	1	PULLEY QD 2V 1/2-5/8 5.950D X SDS 2B56
13	NC14-62-0011	1	QD BUSHING 2B 5.6 OD SDS Ø1 1/4 KW 1/4
14	01-41-0910	1	KEY WAY
15	22-46-3750	1	GASKET

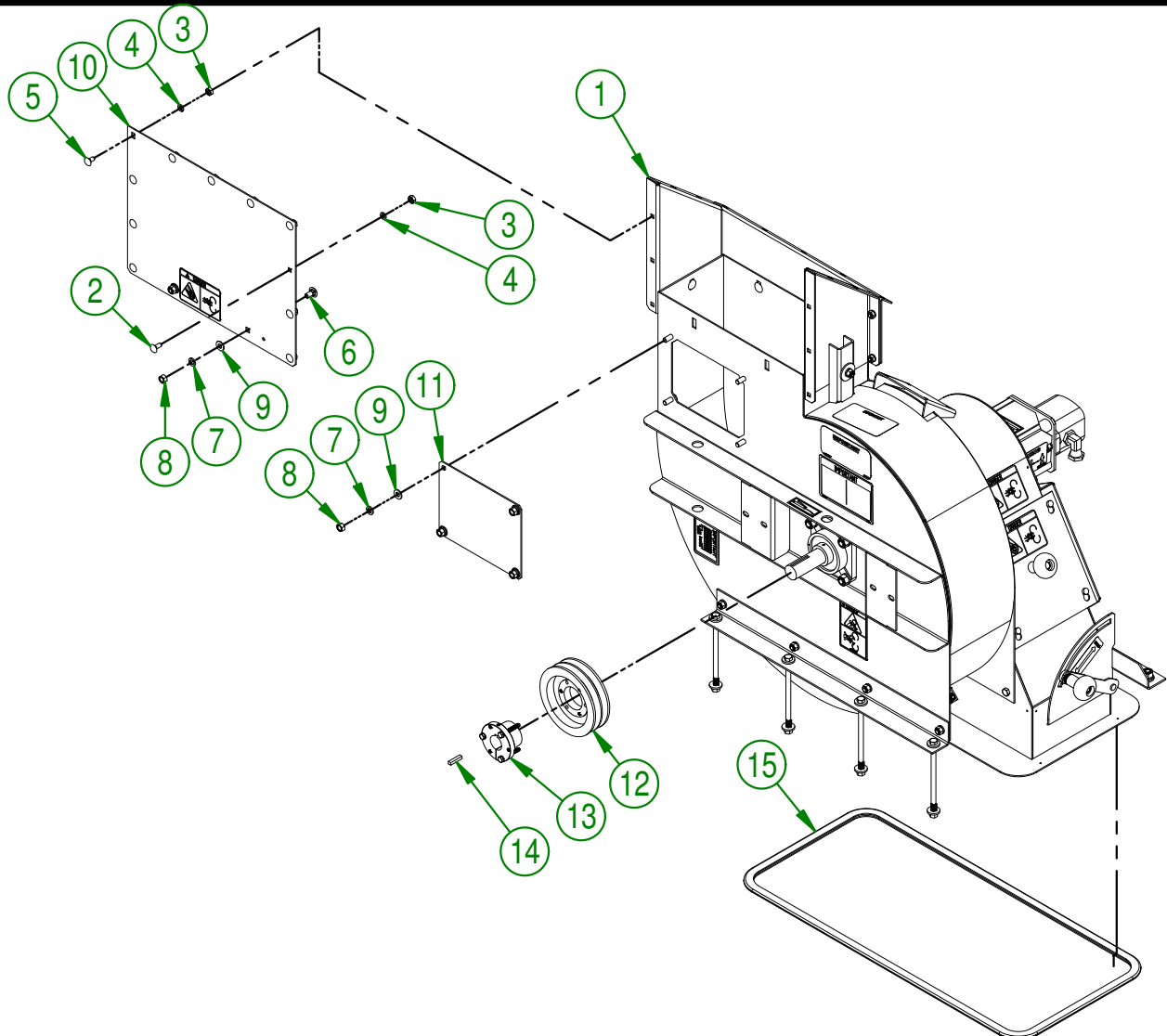
**AGRIMETAL****ASSEMBLY VACUUM BLOWER (HYDRAU. PTO)**

CREATION : 01/11/18
 REVISION : 01/11/18

ASSEMBLY : **22-57-0291**

AUTHOR : F.HÉLIE Page 24 de 67

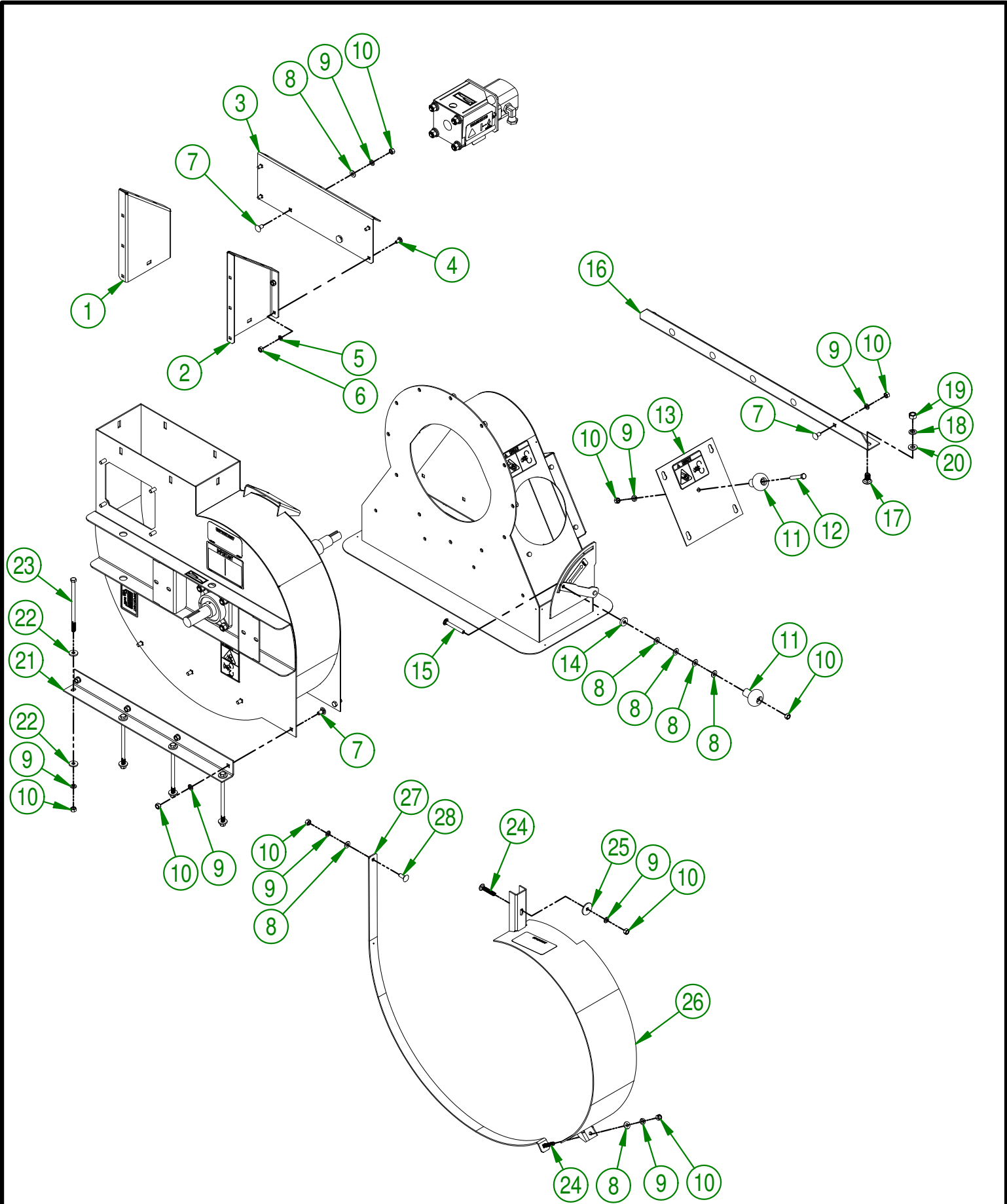

AGRIMETAL	
ASSEMBLY VACUUM BLOWER (PTO)	
CREATION : 01/11/18	ASSEMBLY : 22-55-0006
REVISION : 01/11/18	AUTHOR : F.HÉLIE Page 25 de 67

#	PART #	Qty	TITLE
1	22-01-7570	1	RIGHT SIDE DUCT
2	22-01-7575	1	LEFT SIDE DUCT
3	22-01-7585	1	BACK SIDE DUCT
4	NC01-04-0055	4	CARR. BOLT GR2 ZINC 5/16-18 X 5/8"
5	NC02-32-0011	4	LOCK WASHER ZINC 5/16"
6	NC02-07-0017	4	HEX. NUT 5/16-18
7	NC01-04-0107	11	CARR. BOLT GR2 ZINC 3/8-16 X 3/4"
8	01-01-2485	8	FLAT WASHER 14 GA X 13/16"OD X 25/64" ID
9	NC02-32-0012	19	LOCK WASHER ZINC 3/8"
10	NC02-07-0018	20	HEX. NUT ZINC 3/8-16
11	NC17-46-0018	2	HANDLE KNOB
12	NC01-17-0119	1	HEX. BOLT GR2 ZINC 3/8-16 X 2 1/4"
13	22-57-0630	1	ACCESS DOOR "STICKER INCLUDED"
14	22-42-0100	1	U.H.M.W. FRICTION WASHER
15	NC01-04-0116	1	CARR. BOLT GR2 ZINC 3/8-16 X 2 3/4"
16	22-01-0940	1	BACK SUPPORT
17	NC01-04-0233	2	CARR. BOLT GR2 ZINC 1/2-13 X 1"
18	NC02-32-0014	2	LOCK WASHER ZINC 1/2"
19	NC02-07-0020	2	HEX. NUT ZINC 1/2-13
20	01-01-0925	2	WASHER
21	22-01-1110	1	FRONT SUPPORT
22	21-01-0950	8	FLAT WASHER 10GA 1.005" DIA X 25/64"
23	NC01-17-0138	4	HEX BOLT. GR2 NC ZINC 3/8-16 X 7" LG.
24	NC01-02-0113	2	CARR. BOLT GR2 ZINC 3/8-16 X 2"
25	01-33-0010	1	WASHER
26	22-57-0625	1	BLOWER HALF-CONTOUR GROUP " STICKER INCLUDED"
27	22-50-0175	1	BLOWER HALF-CONTOUR BELT
28	NC01-04-0109	1	CARR. BOLT GR2 ZINC 3/8-16 X 1"

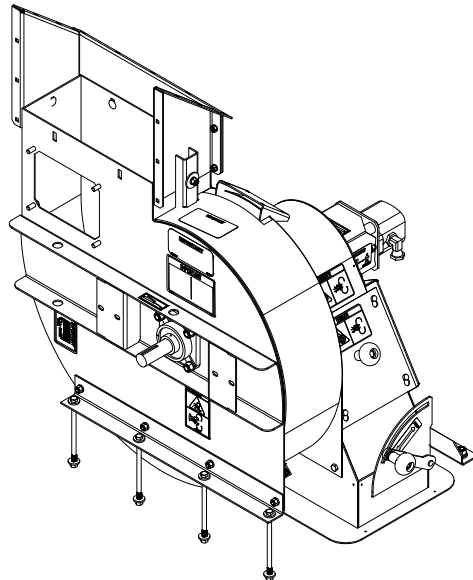
**AGRIMETAL****ASSEMBLY VACUUM BLOWER (PTO)**

CREATION : 01/11/18
 REVISION : 01/11/18

ASSEMBLY : **22-55-0006**

AUTHOR : F.HÉLIE Page 26 de 67

#	PART #	Qty	TITLE
1	22-55-0231	1	BLOWER CASING
2	22-50-0097	1	IMPELLER
3	NC02-32-0014	4	LOCK WASHER ZINC 1/2"
4	NC02-07-0020	4	HEX. NUT ZINC 1/2-13
5	12-38-0001	1	FLANGE BEARING UCF 207-20

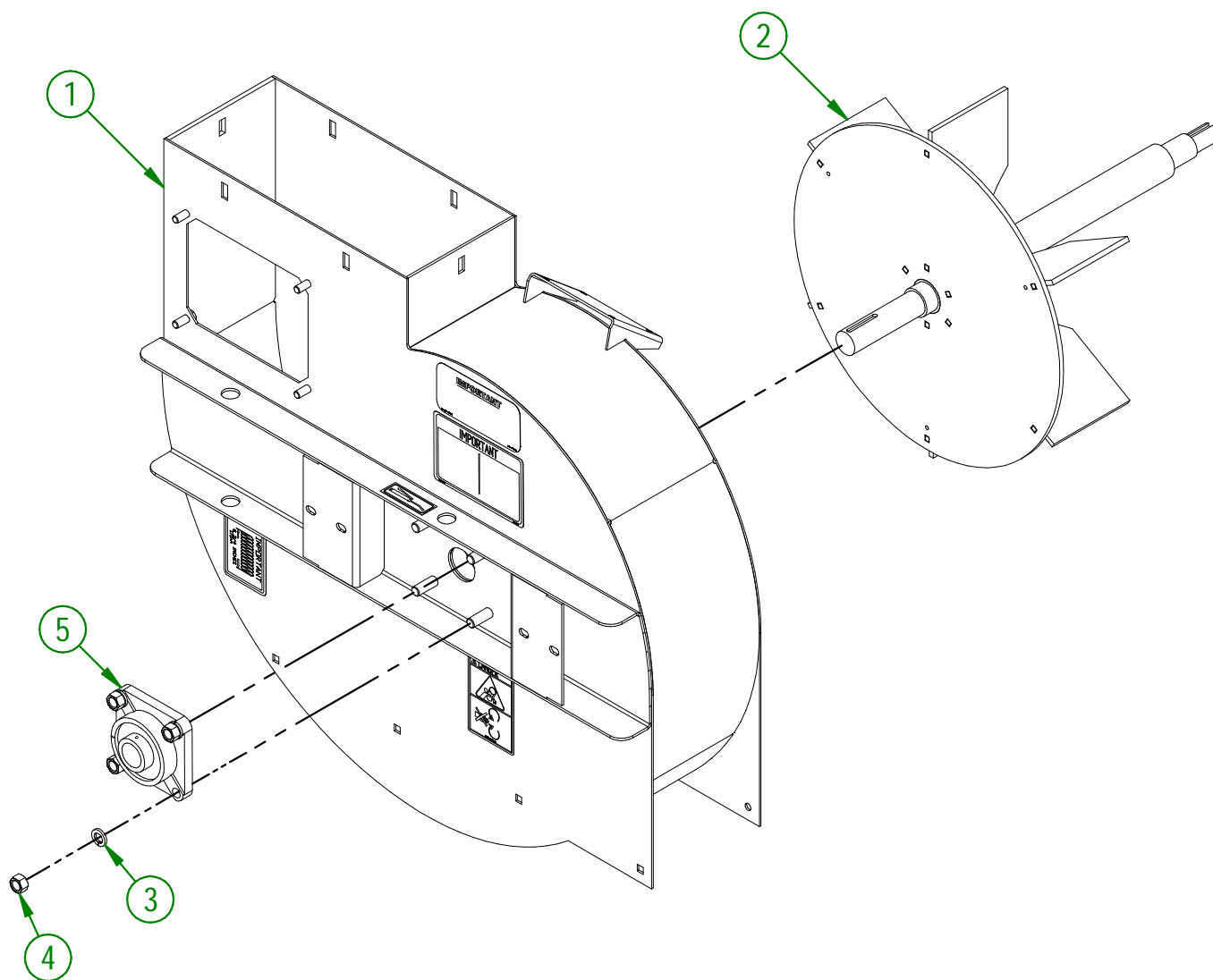

AGRIMETAL	
ASSEMBLY CASING BLOWER	
CREATION : 2025-12-02	ASSEMBLY : 22-57-0121
REVISION : 2025-12-02	AUTHOR :

#	PART #	Qty	TITLE
1	22-57-0640	1	ASSEMBLY SUCTION FUNNEL BOX "STICKER INCLUDED"
2	22-21-0000	7	TAPER WASHER
3	22-21-0015	2	TAPER WASHER SPECIAL
4	NC02-32-0012	16	LOCK WASHER ZINC 3/8"
5	NC02-07-0018	16	HEX. NUT ZINC 3/8-16
6	01-01-2485	7	FLAT WASHER

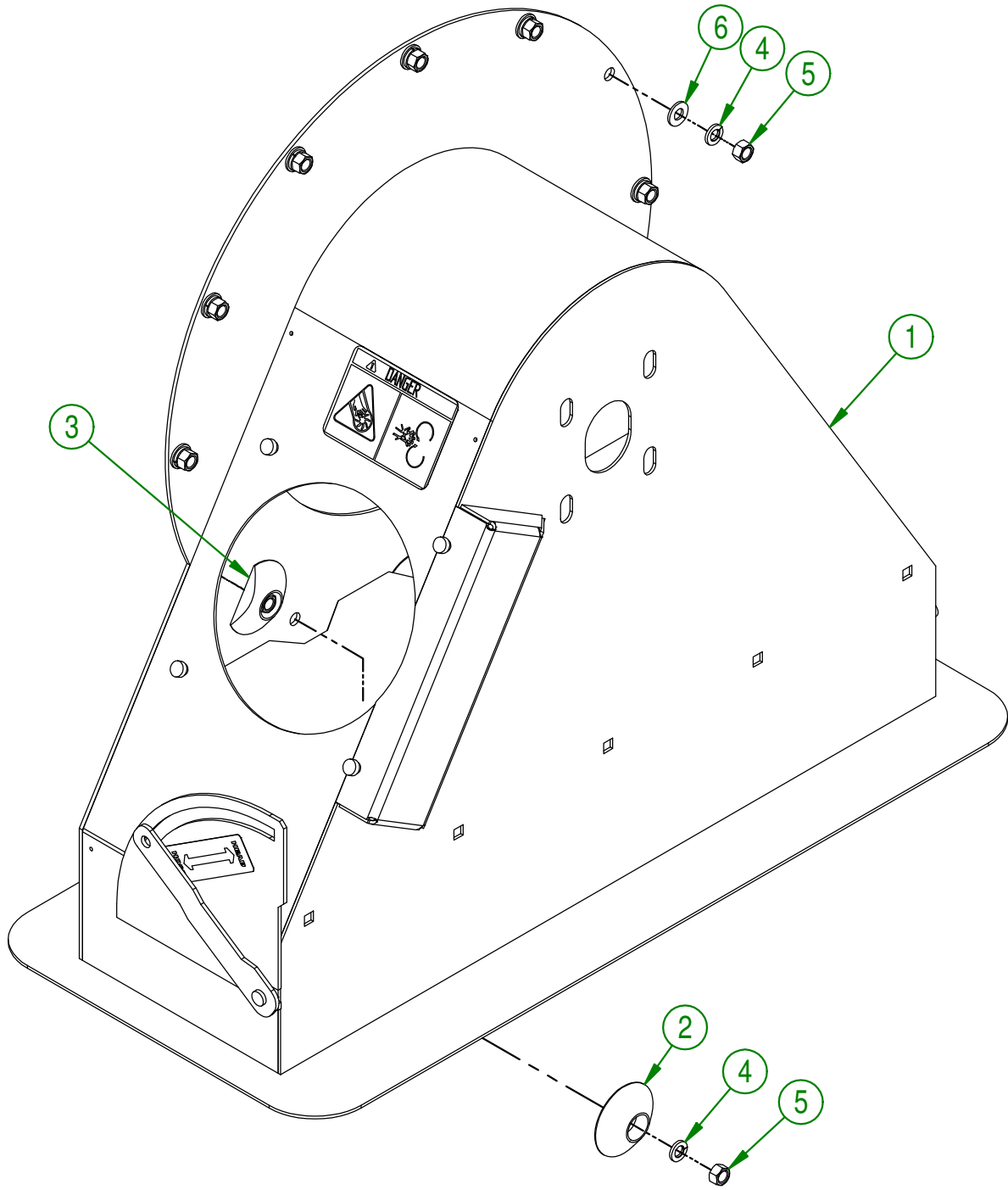

AGRIMETAL			
ASSEMBLY SUCTION FUNNEL BOX			
CREATION : 2016-10-14	ASSEMBLY :	22-57-0125	
REVISION : 2018-05-04	AUTHOR : S.B.	Page 28 de 67	

#	PART #	Qty	TITLE
1	NC14-45-0024	1	HYDRAULIC PUMP
2	16-04-6855	1	HYDRAULIC PUMP SUPPORT
3	NC01-17-0115	2	HEX. BOLT GR2 ZINC 3/8-16 X 1 1/4"
4	01-01-2485	2	FLAT WASHER
5	NC02-32-0012	2	LOCK WASHER ZINC 3/8"
6	NC02-07-0018	2	HEX. NUT ZINC 3/8-16
7	16-36-1800	1	SPROCKET #4016 X Ø3/4" KW 3/16" 2 SS 5/16-18
8	01-36-1815	1	SPROCKET #4016 X Ø1" KW 1/4" 2 SS 5/16-18
9	NC02-44-0103	4	SET SCREW 5/16-18 X 3/8"
10	NC14-20-0030	1	CHAIN 4016
11	16-30-9965	2	HYDRAULIC PUMP BOLT
12	NC01-17-0269	2	HEX. BOLT GR2 ZINC 1/2-13 X 6 1/2"
13	16-09-0800	4	LONG BUSING
14	NC02-25-0011	4	WASHER SAE ZINC 17/32 ID
15	NC02-32-0014	4	LOCK WASHER ZINC 1/2"
16	NC02-07-0020	4	HEX. NUT ZINC 1/2-13
17	16-38-0000	1	PILLOW BLOCK BEARING Ø1 1/4" UCF 207-20
18	NC13-45-0028	2	ELBOW 90° 7/8-14 MALE SAE O RING X 1/2 FEM NPT
19	22-55-0225	1	CHAIN COUPLING GUARD

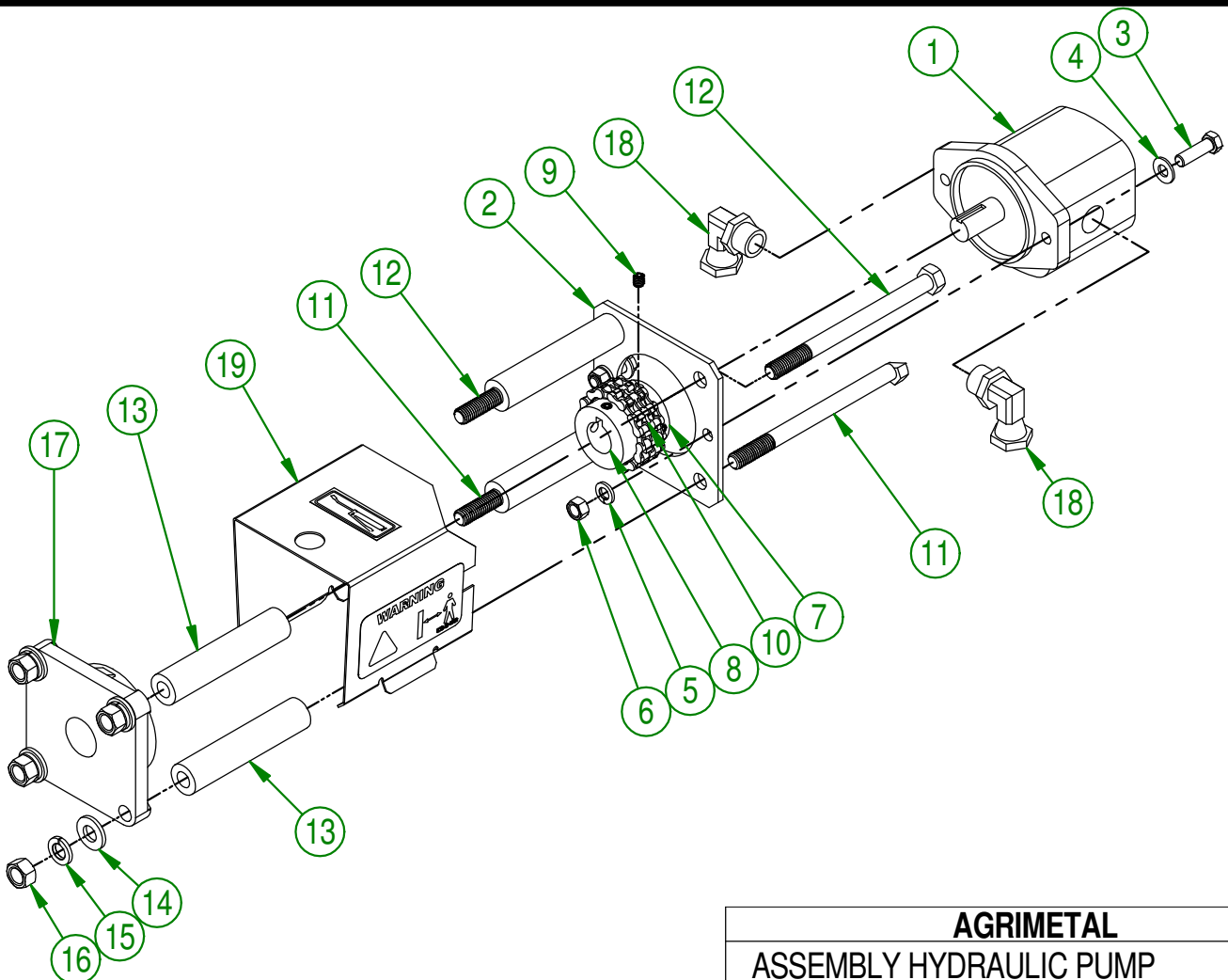

AGRIMETAL	
ASSEMBLY HYDRAULIC PUMP	
CREATION : 2016-10-14	ASSEMBLY : 22-57-0110
REVISION : 2018-05-09	AUTHOR : S.B. Page 29 de 67

#	PART #	Qty	TITLE
1	NC14-70-0074	1	ASSEMBLY AXEL
2	NC14-70-0077	2	ASSEMBLY WHEEL 23"
3	NC02-12-0005	10	HEX. NUT ZINC 1/2-20

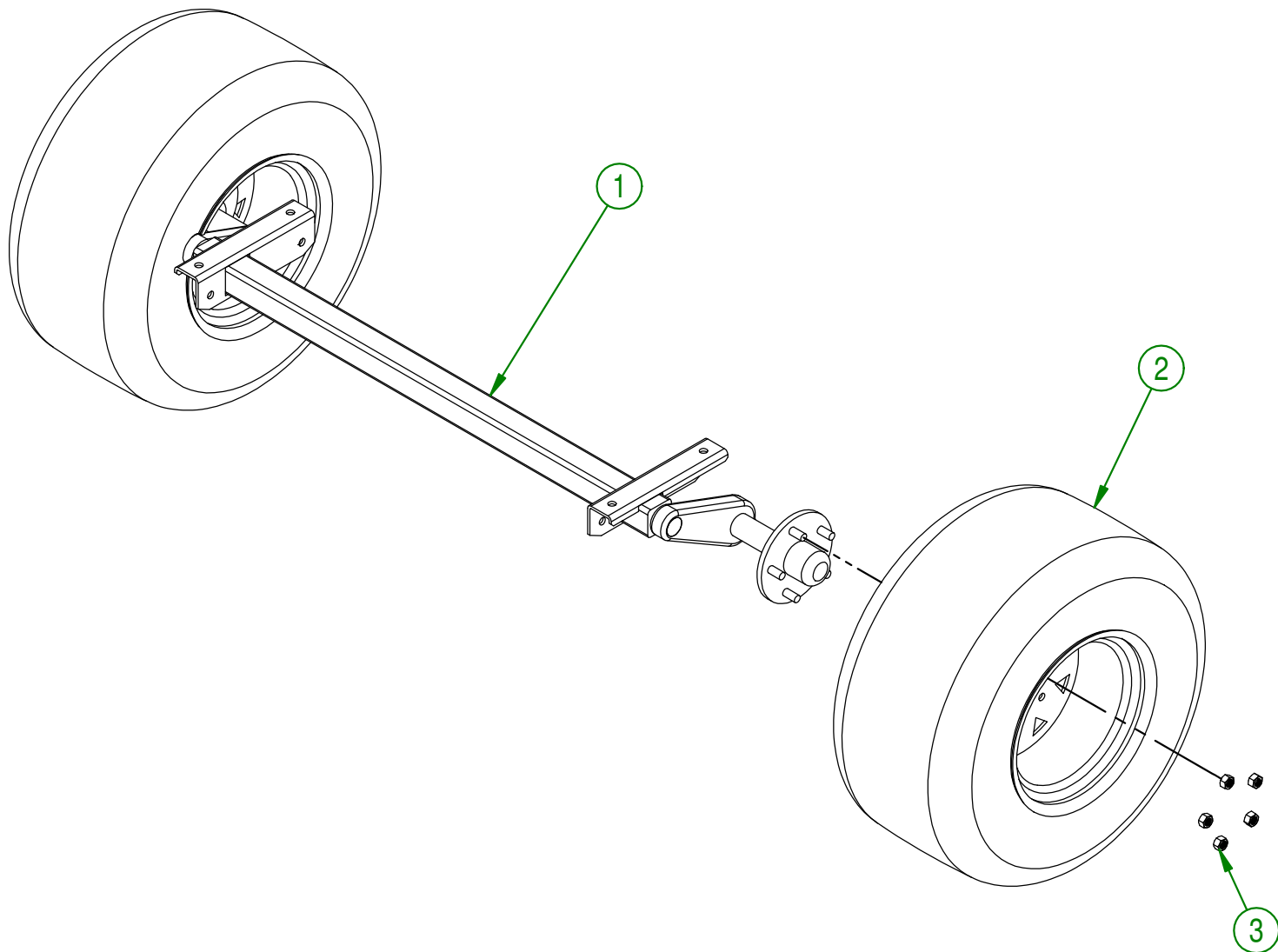

AGRIMETAL			
ASSEMBLY AXEL			
CREATION : 2016-10-14	ASSEMBLY :	22-57-0075	
REVISION : 2018-05-04	AUTHOR : S.B.	Page 30 de 67	

#	PART #	Qty	TITLE
1	22-50-0110	1	LEFT BOX SUPPORT
2	22-50-0115	1	RIGHT BOX SUPPORT
3	NC01-04-0055	12	CARR. BOLT GR2 ZINC 5/16-18 X 5/8"
4	NC02-32-0011	12	LOCK WASHER ZINC 5/16"
5	NC02-07-0017	12	HEX. NUT 5/16-18

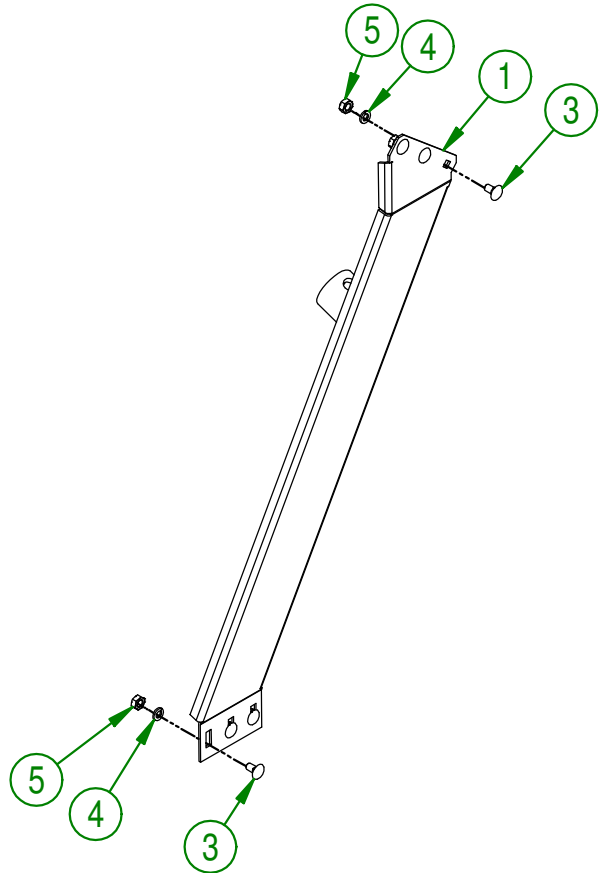
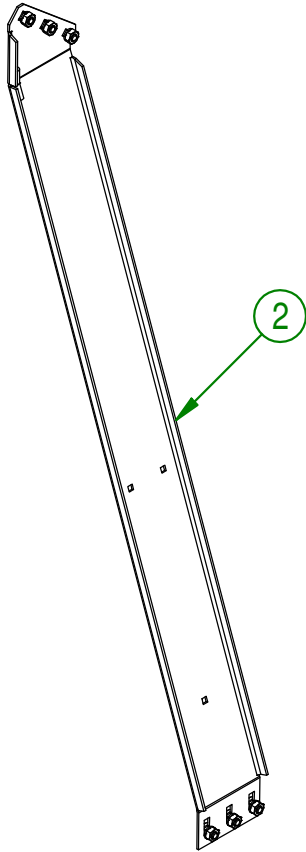

AGRIMETAL	
BOX SUPPORT	
CREATION : 2016-10-14	ASSEMBLY : 22-57-0170
REVISION : 2018-05-04	AUTHOR : S.B. Page 31 de 67

#	PART #	Qty	TITLE
1	22-57-0650	1	BACK DOOR "STICKER INCLUDED"
2	22-04-0005	1	LEFT DOOR LOCK
3	22-04-0007	1	RIGHT DOOR LOCK
4	NC01-02-0112	4	CARR. BOLT GR2 FLZ 3/8-16 X 1 3/4"
5	NC02-32-0012	4	LOCK WASHER ZINC 3/8"
6	NC02-07-0018	4	HEX. NUT ZINC 3/8-16
7	NC01-17-0255	2	HEX. BOLT GR2 ZINC 1/2-13 X 3"
8	01-01-0925	2	WASHER
9	NC01-17-0074	2	HEX. BOLT ZINC GR2 5/16-18 X 4 1/2"
10	NC02-22-0008	2	WASHER ZINC 5/16"
11	NC02-32-0011	2	LOCK WASHER ZINC 5/16"
12	NC02-07-0017	4	HEX. NUT 5/16-18

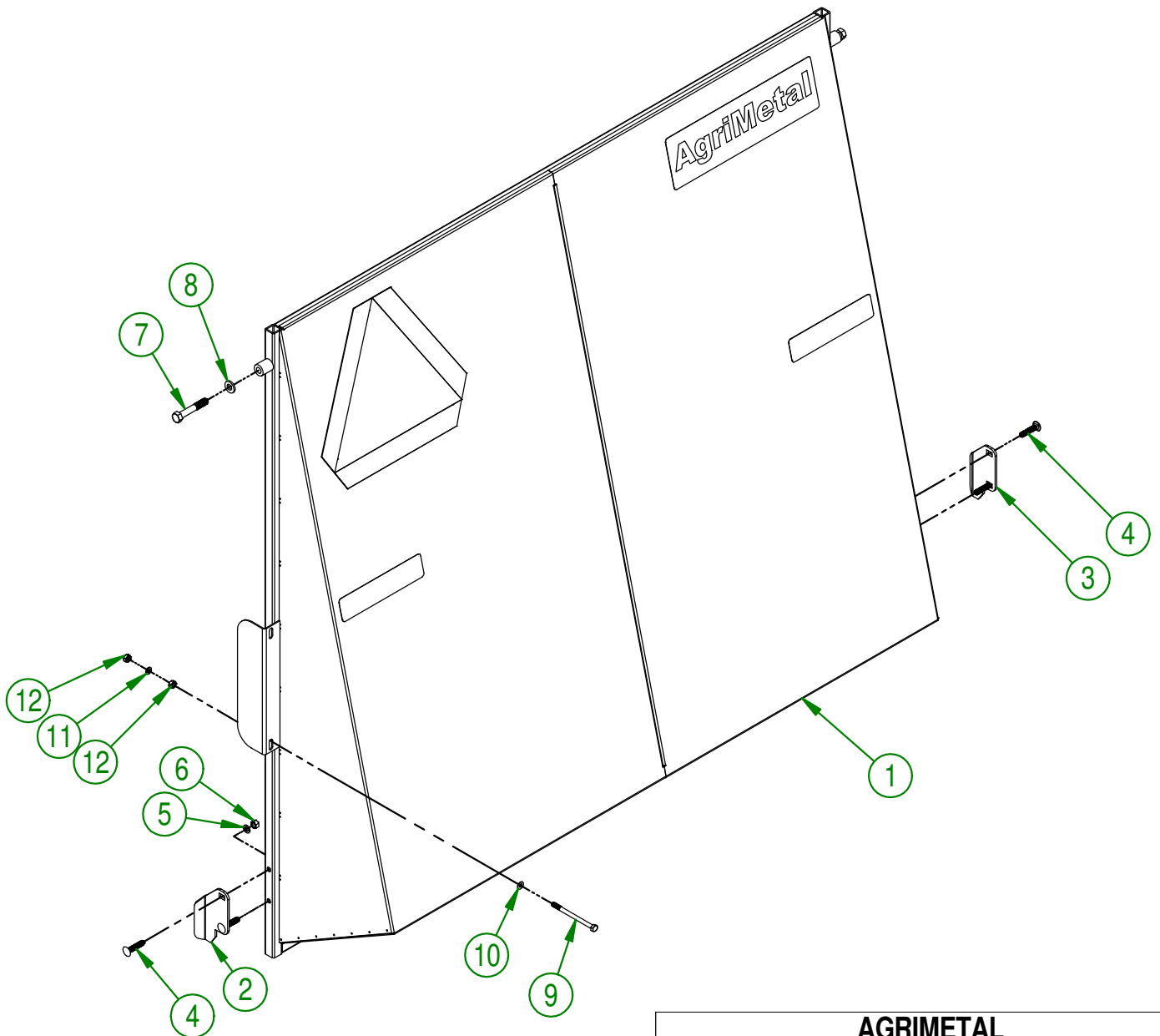

AGRIMETAL		
ASSEMBLY BACK DOOR		
CREATION : 2016-10-18	ASSEMBLY :	22-57-0185
REVISION : 2018-05-04	AUTHOR : S.B.	Page 32 de 67

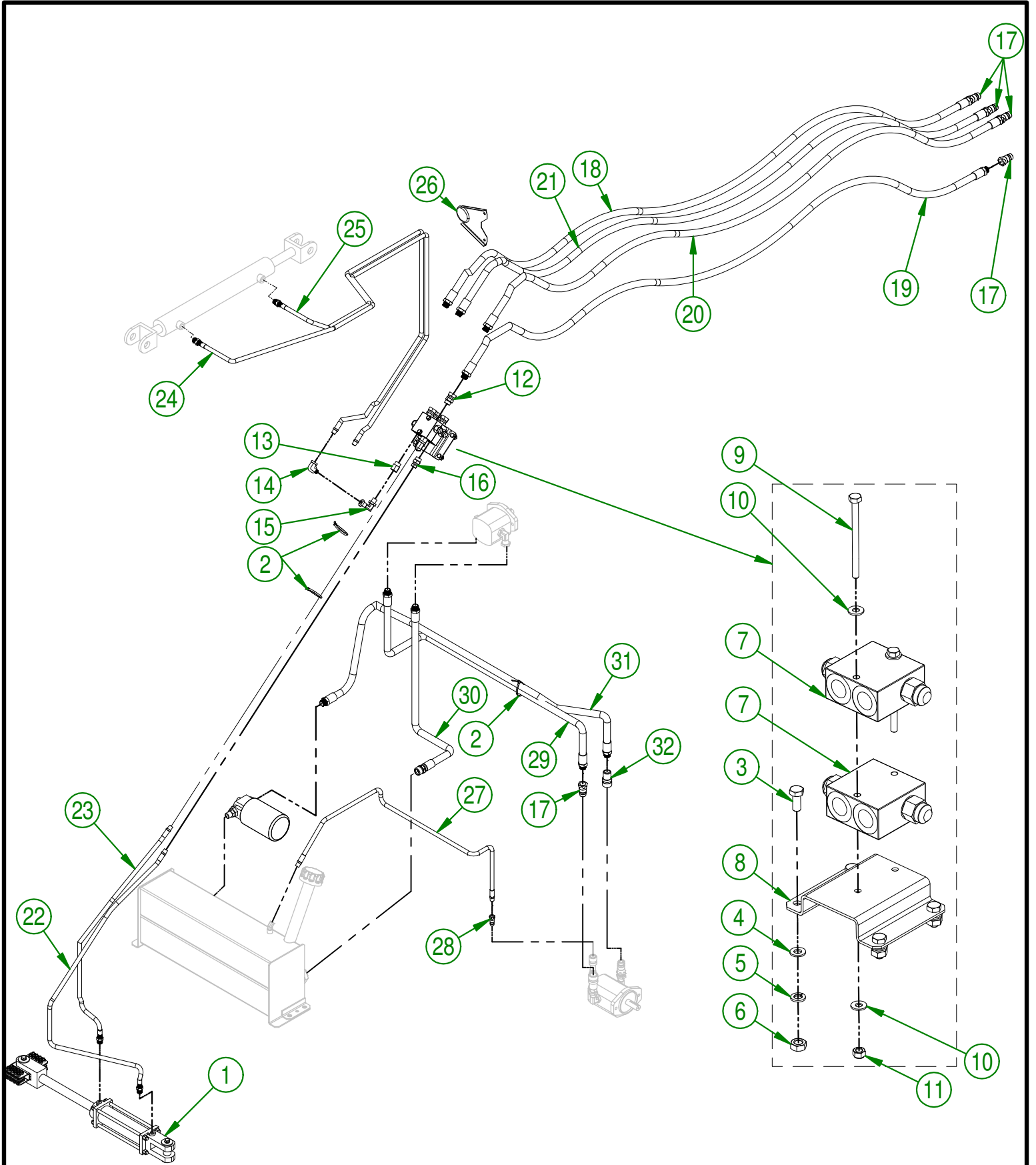

AGRIMETAL	
HYDRAULIC SYSTEM GROUP (PTO-HOSE)	
CREATION : 25/04/18	ASSEMBLY : 22-57-0201
REVISION : 25/05/18	AUTHOR : F.HÉLIE Page 33 de 67

#	PART #	Qty	TITLE
1	22-57-0220	1	CYLINDER HEAD GROUP
2	NC13-25-0019	3	BLACK TIE RAP
3	NC01-17-0058	4	HEX. BOLT GR2 ZINC 5/16-18 X 3/4"
4	NC02-22-0008	4	WASHER ZINC 5/16"
5	NC02-32-0011	4	LOCK WASHER ZINC 5/16"
6	NC02-07-0017	4	HEX. NUT 5/16-18
7	NC13-45-0181	2	HYDRAULIC VALVE
8	22-01-7715	1	HYDRAULIC VALVE SUPPORT
9	NC01-17-0016	2	HEX BOLT. GR2 NC ZINC 1/4-20 X 3 1/2" LG
10	NC02-25-0007	4	WASHER ZINC 0.281 = 9/32
11	NC01-96-0009	2	NYLON-INSERT LOCKNUT ZINC 1/4-20
12	NC13-45-0204	4	STRAIGHT REDUCER 3/4-16 MALE SAE8 O RING X 1/2 FEMALE
13	NC13-45-0186	2	REDUCER STREIGHT 3/4-16 MALE SAE8 O RING X 9/16-18 FEMALE
14	NC13-45-0142	2	90° 1/4 FEMELLE NPT X 1/4 MALE NPT
15	NC13-45-0108	2	ELBOW 90° 9/16-18 MALE SAE6 O RING
16	NC13-45-0204	2	STRAIGHT REDUCER 3/4-16 MALE SAE8 O RING X 1/4 FEMALE
17	NC13-45-0014	5	QUICK COUPLER 1/2-14 NPTF
18	NC17-02-0349	1	HYD.HOSE. 1/2" X 84" 1/2NPT MALE RIG. X 1/2" NPT MALE RIG.
19	NC17-02-0349	1	HYD.HOSE. 1/2" X 84" 1/2NPT MALE RIG. X 1/2" NPT MALE RIG.
20	NC17-02-0349	1	HYD.HOSE. 1/2" X 84" 1/2NPT MALE RIG. X 1/2" NPT MALE RIG.
21	NC17-02-0349	1	HYD.HOSE. 1/2" X 84" 1/2NPT MALE RIG. X 1/2" NPT MALE RIG.
22	NC17-02-0320	1	HYDRAULIC HOSE 1/4 X 35"
23	NC17-02-0322	1	HYDRAULIC HOSE 1/4 X 45"
24	NC17-02-0324	1	HYDRAULIC HOSE 1/4 X 85"
25	NC17-02-0323	1	HYDRAULIC HOSE 1/4 X 75"
26	22-50-0205	1	HYDRAULIC HOSE HOLDER
27	NC17-02-0321	1	HYDRAULIC HOSE 1/4 X 44 1/2"
28	NC13-45-0112	1	QUICK COUPLER MALE 1/4-18 NPTF
29	NC17-02-0327	1	HYDRAULIC HOSE 1/2 X 43 1/2"
30	NC17-02-0325	1	HYDRAULIC HOSE 1/2 X 24"
31	NC17-02-0348	1	HYDRAULIC HOSE 1/2 X 43 1/2"
32	NC13-45-0047	1	QUICK COUPLER FEMALE 1/2-14 NPTF

AGRIMETAL**HYDRAULIC SYSTEM GROUP (PTO-HOSE)**

CREATION : 25/04/18
REVISION : 25/05/18

ASSEMBLY : **22-57-0201**

AUTHOR : F.HÉLIE Page 34 de 67

PTO SYSTEM
(CABLE ONLY)

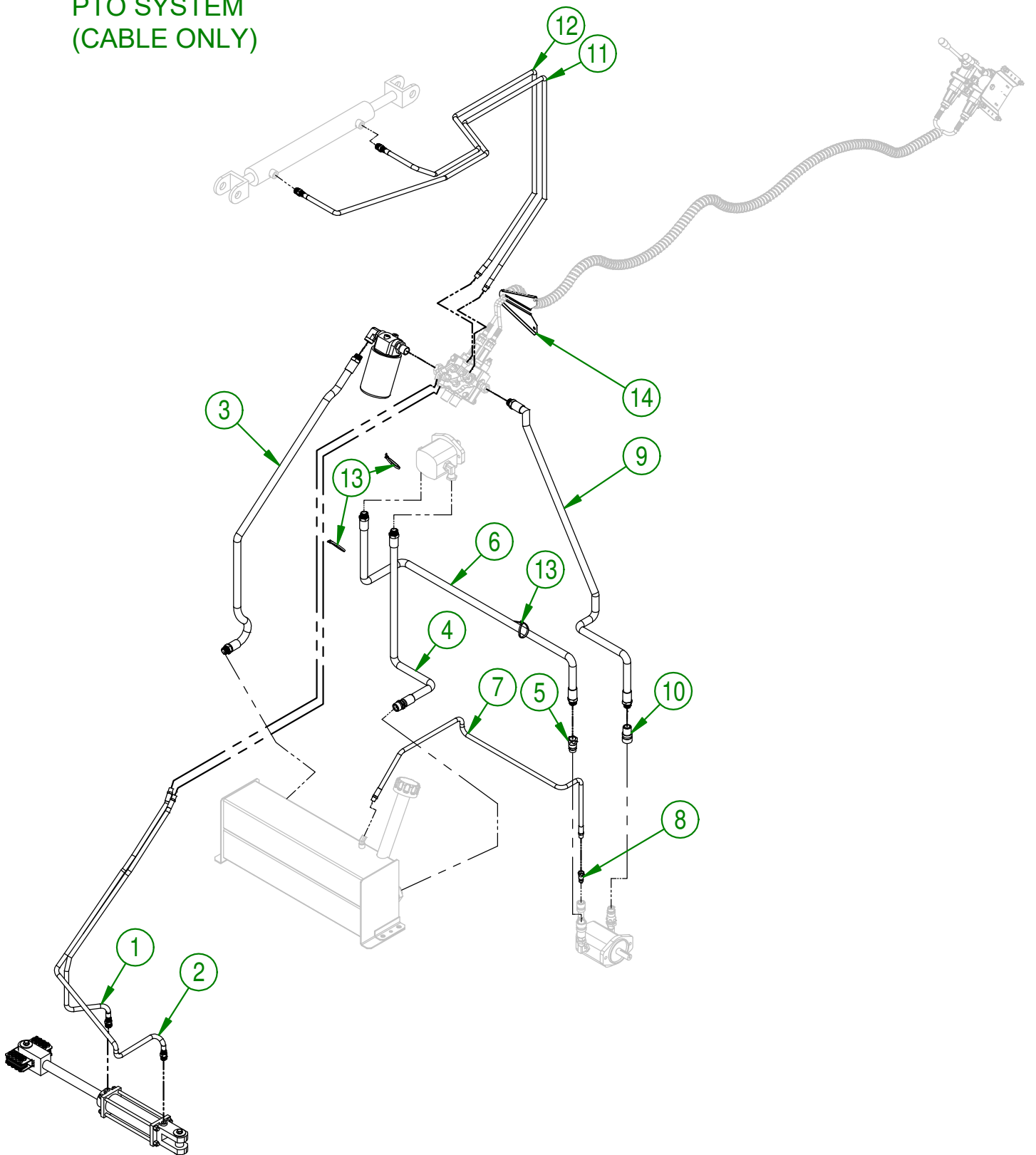

AGRIMETAL	
HYDRAULIC SYSTEM GROUP (PTO- CABLE)	
CREATION : 24/05/18	ASSEMBLY : 22-57-0200
REVISION : 29/05/18	AUTHOR : F.HÉLIE Page 35 de 67

22-57-0200

#	PART #	Qty	TITLE
1	NC17-02-0320	1	HYDRAULIC HOSE 1/4 X 35"
2	NC17-02-0322	1	HYDRAULIC HOSE 1/4 X 45"
3	NC17-02-0326	1	HYDRAULIC HOSE 1/2 X 40"
4	NC17-02-0325	1	HYDRAULIC HOSE 1/2 X 24"
5	NC13-45-0014	1	QUICK COUPLER 1/2-14 NPTF
6	NC17-02-0327	1	HYDRAULIC HOSE 1/2 X 43 1/2"
7	NC17-02-0321	1	HYDRAULIC HOSE 1/4 X 44 1/2"
8	NC13-45-0112	1	QUICK COUPLER MALE 1/4-18 NPTF
9	NC17-02-0327	1	HYDRAULIC HOSE 1/2 X 43 1/2"
10	NC13-45-0047	1	QUICK COUPLER FEMALE 1/2-14 NPTF
11	NC17-02-0324	1	HYDRAULIC HOSE 1/4 X 85"
12	NC17-02-0323	1	HYDRAULIC HOSE 1/4 X 75"
13	NC13-25-0019	3	BLACK TIE RAP
14	22-01-3160	1	HYDRAULIC CONTROL CABLE SUPPORT

AGRIMETAL

HYDRAULIC SYSTEM GROUP (PTO- CABLE)

CREATION : 24/05/18
 REVISION : 29/05/18

ASSEMBLY : **22-57-0200**
 AUTHOR : F.HÉLIE Page 36 de 67

PTO-CABLE SYSTEM ONLY

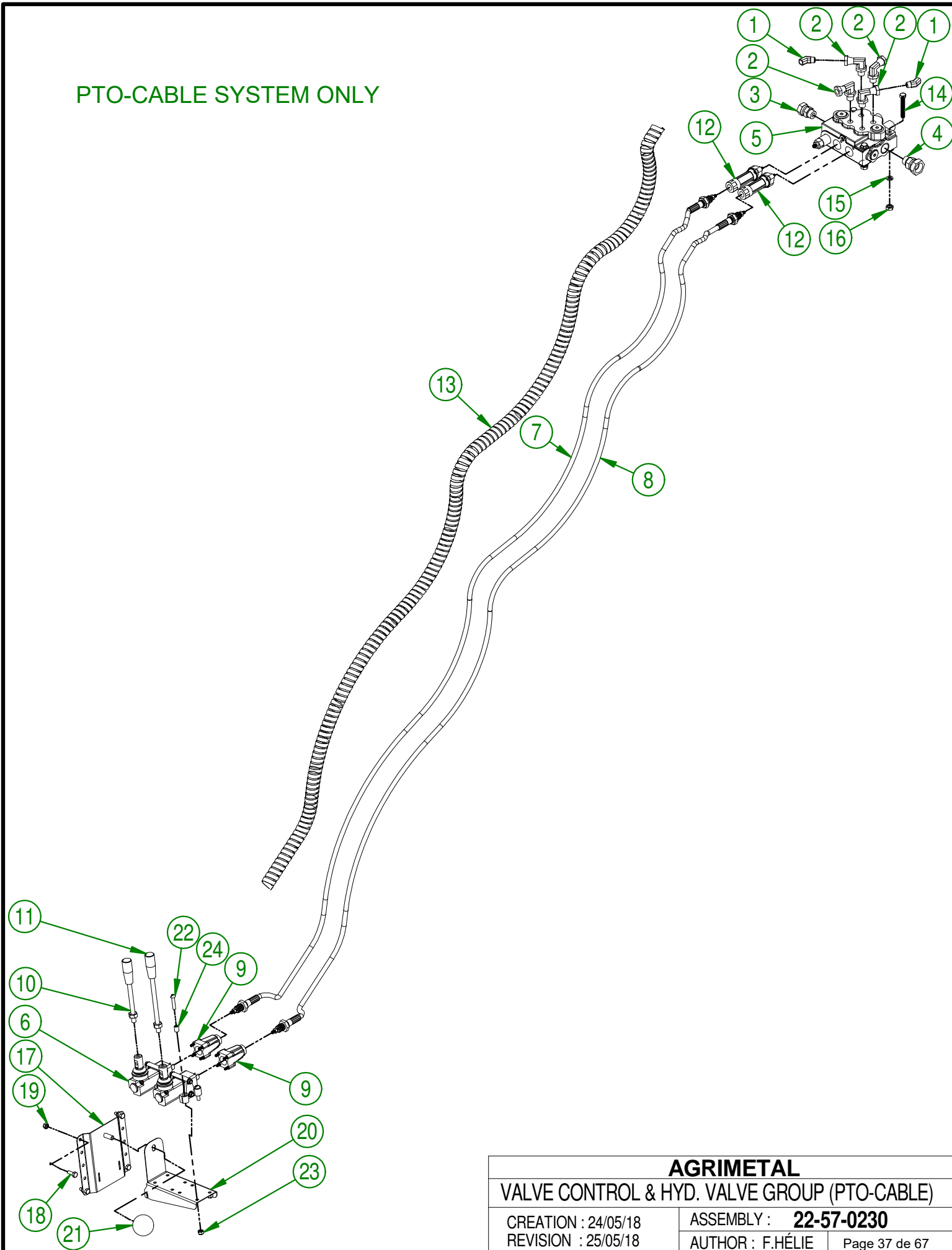

AGRIMETAL	
VALVE CONTROL & HYD. VALVE GROUP (PTO-CABLE)	
CREATION : 24/05/18	ASSEMBLY : 22-57-0230
REVISION : 25/05/18	AUTHOR : F.HÉLIE Page 37 de 67

#	PART #	Qty	TITLE
1	NC13-45-0109	2	ELBOW 45° 1/4 NPT FEM. X 1/4 NPT MALE
2	NC13-45-0108	4	ELBOW 90° 9/16-18 MALE SAE6 O RING
3	NC13-45-0106	1	STRAIGHT REDUCER 3/4-16 MALE SAE8 O RING X 1/2 FEMALE
4	NC13-45-0110	1	STRAIGHT UNION 3/4-16 MALE SAE8 O RING X 3/4 FEMALE
5	NC13-45-0130	1	HYDRAULIC VALVE
6	NC13-45-0131	2	VALVE KIT
7	NC13-45-0116	1	CABLE
8	NC13-45-0116	1	CABLE
9	NC13-45-0126	2	CABLE FITTING
10	NC13-45-0222	1	LEVER SHAFT (150 mm)
11	NC13-45-0228	1	LEVER SHAFT (200 mm)
12	NC13-45-0127	2	CABLE FITTING
13	22-42-0250	1	BLACK WIRE PROTECTOR 80"
14	NC01-17-0065	3	HEX. BOLT GR2. ZINC 5/16-18 X 2 1/4"
15	NC02-32-0011	3	LOCK WASHER ZINC 5/16"
16	NC02-07-0017	3	HEX. NUT 5/16-18
17	22-50-0150	1	HYDRAULIC CONTROL SUPPORT
18	NC01-37-0004	4	HEX. BOLT GR2 ZINC 1/4-28 X 3/4"
19	NC01-97-0004	4	NYLON-INSERT LOCKNUT ZINC 1/4-28
20	22-01-3100	1	HYDRAULIC CONTROL SUPPORT
21	NC01-64-0232	1	BLACK BALL 1 7/8" X 3/8-16
22	NC02-40-0108	8	MACHINE SCREW 1/4-20 X 1 1/4"
23	NC01-96-0009	8	NYLON-INSERT LOCKNUT ZINC 1/4-20
24	22-42-0010	8	PLASTIC BUSHING

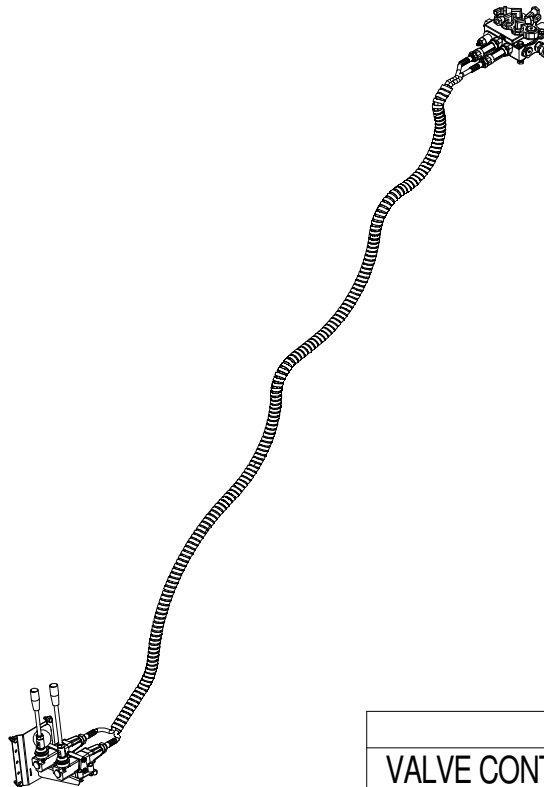
**AGRIMETAL**

VALVE CONTROL & HYD. VALVE GROUP (PTO-CABLE)

CREATION : 24/05/18
 REVISION : 25/05/18

ASSEMBLY : **22-57-0230**

AUTHOR : F.HÉLIE Page 38 de 67

#	PART #	Qty	TITLE
1	NC13-45-0029	1	HEX. NIPPLE 1/2 MALE NPT X 1/2 MALE NPT
2	NC13-45-0032	2	STRAIGHT HOSE FITTING 1/2 FEM. NPT X 3/4 MALE NPT
3	NC13-45-0048	1	OIL FILTER
4	NC13-45-0049	1	HEAD FILTER

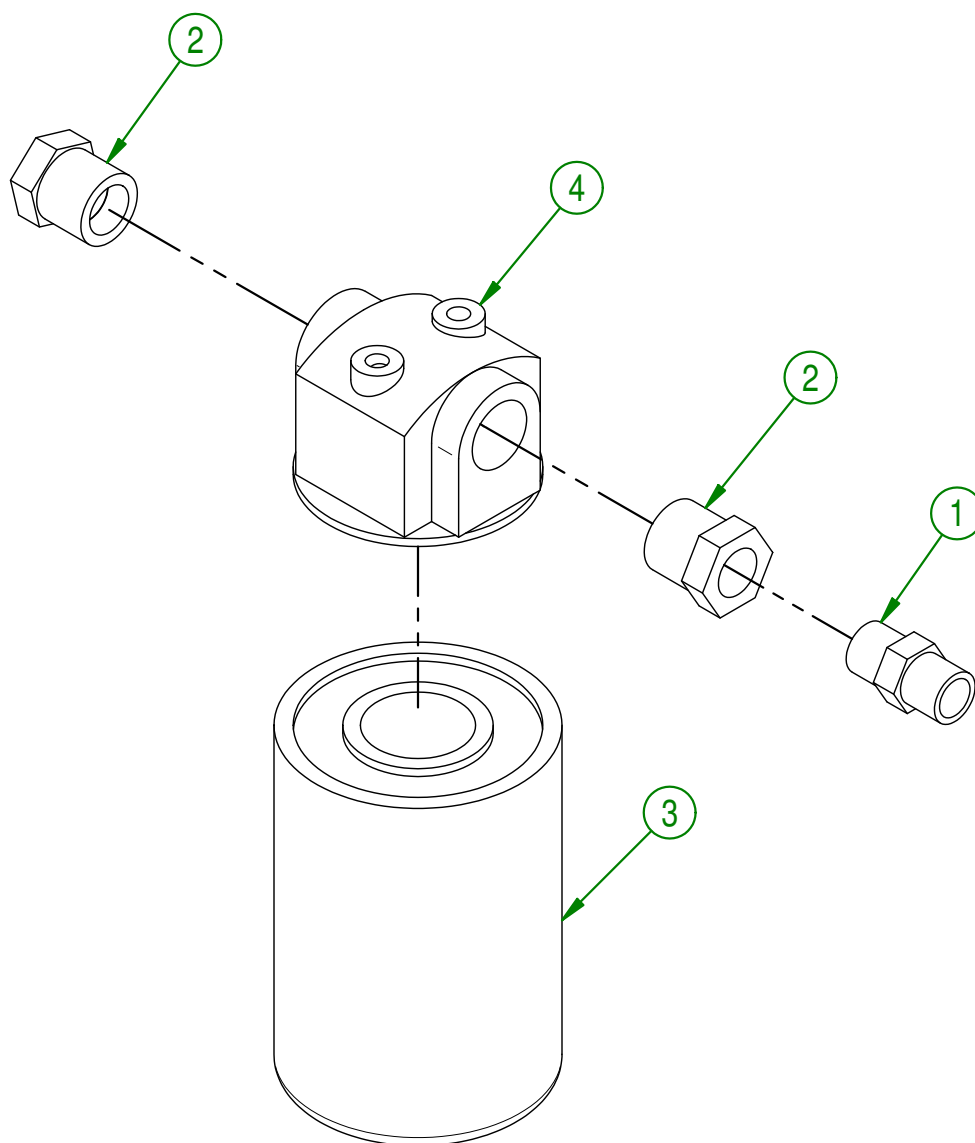

AGRIMETAL		
OIL FILTER		
CREATION : 25-04-2018	ASSEMBLY :	22-55-0096
REVISION : 18-01-2019	AUTHOR :	Page 39 de 67

#	PART #	Qty	TITLE
1	22-55-0200	1	CYLINDER 2 3/8" OD X 1 1/8" ROD X 7" TRAVEL
2	22-01-7630	2	CABLE CLAMP
3	22-22-5600	12	GAUGE PLATE
4	NC01-17-0008	16	HEX. BOLT GR2 ZINC 1/4-20 X 1 1/2"
5	NC01-96-0009	16	NYLON-INSERT LOCKNUT ZINC 1/4-20
6	22-13-1420	2	CYLINDER PIN
7	NC01-17-0114	4	HEX. BOLT GR2 ZINC 3/8-16 X 1"
8	NC02-32-0012	4	LOCK WASHER ZINC 3/8"
9	01-33-0010	4	WASHER
10	01-01-2485	1	FLAT WASHER 14 GA X 13/16"OD X 25/64" ID
11	NC13-45-0391	2	STRAIGHT UNION

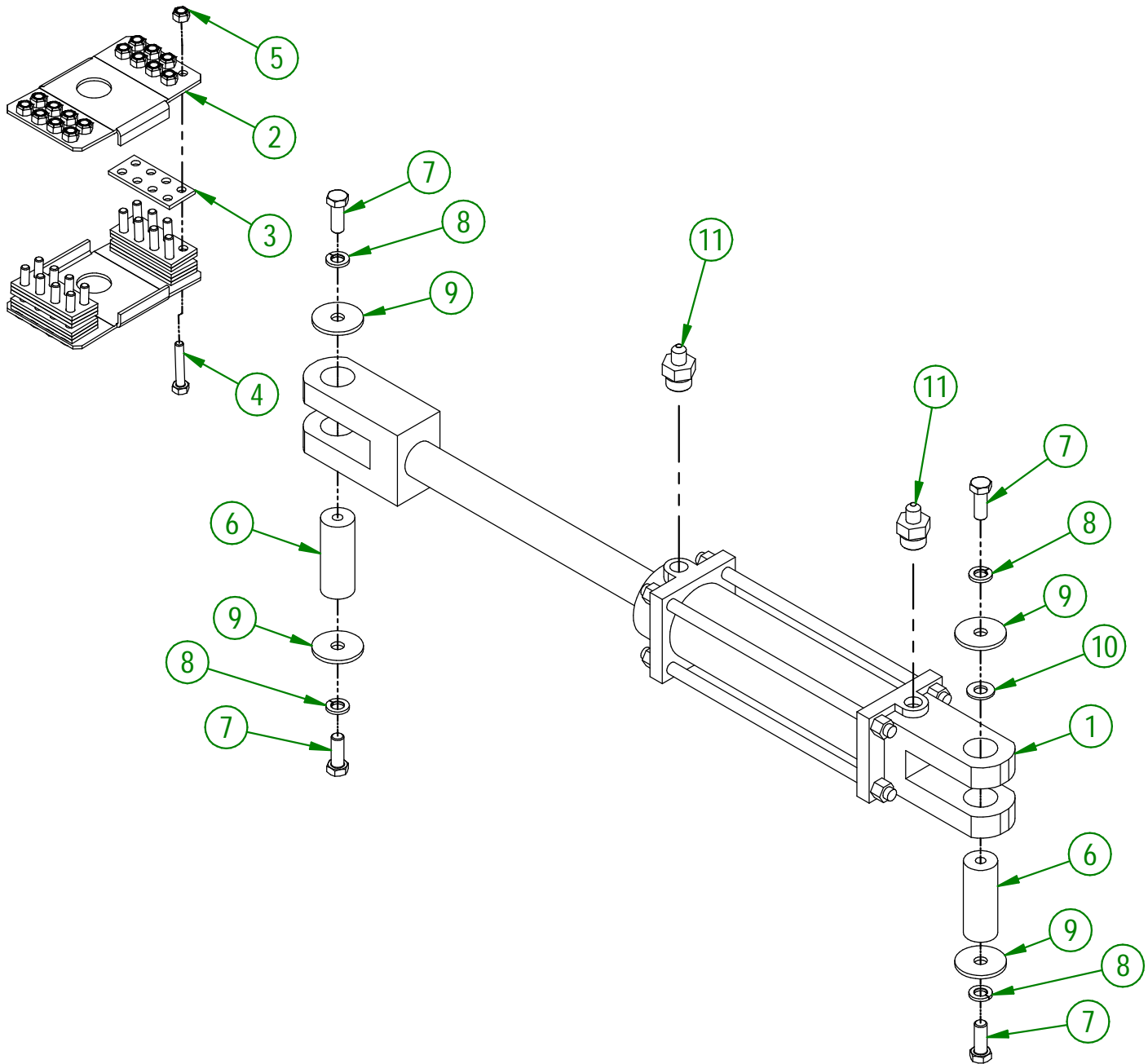

AGRIMETAL	
CYLINDER HEAD GROUP	
CREATION : 2016-10-18	ASSEMBLY : 22-57-0220
REVISION : 2023-04-24	AUTHOR : S.B.

#	PART #	Qty	TITLE
1	22-55-0100	1	CABLE PICK UP HEAD 3/16" X 45"
2	22-55-0105	1	CABLE PICK UP HEAD 3/16" X 73 1/2"
3	22-20-0255	2	CABLE LOCK PIN
4	NC01-63-0014	2	COTTER PIN Z 3/32" X 1 3/4" LG
5	12-42-0100	5	DEFLECTOR PULLEY
6	12-09-0100	5	BUSHING 3/4"
7	NC01-69-0463	5	SPRING PIN 1/4" X 1 3/4"
8	NC01-17-0252	5	HEX. BOLT GR2 ZINC 1/2-13 X 2 1/4"
9	NC02-32-0014	5	LOCK WASHER ZINC 1/2"
10	NC02-07-0020	5	HEX. NUT ZINC 1/2-13

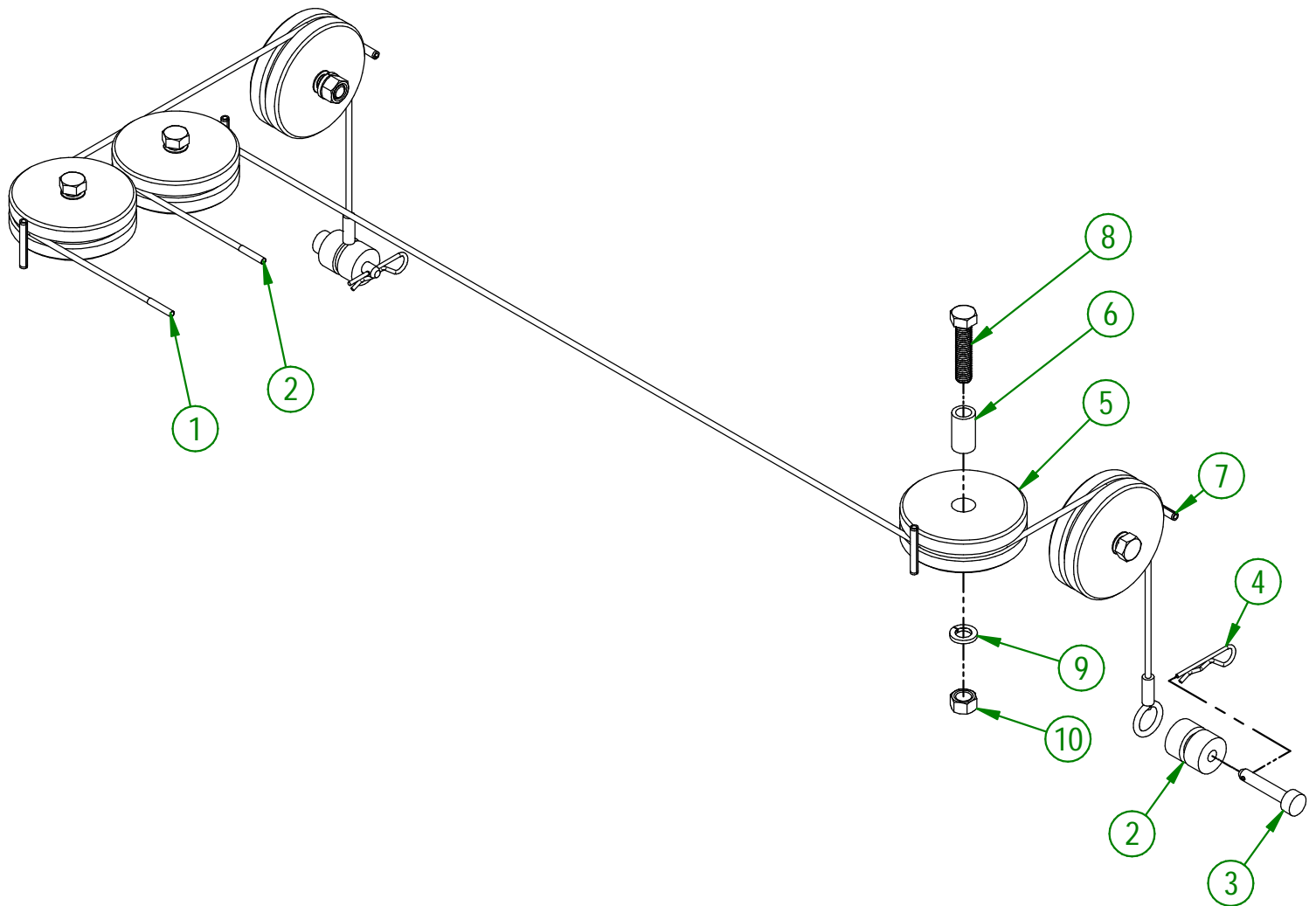

AGRIMETAL	
ASSEMBLY PICK UP HEAD HYDRAULIC LIFTING SYSTEM	
CREATION : 2016-10-19	ASSEMBLY : 22-57-0215
REVISION : 2023-02-09	AUTHOR : S.B.

#	PART #	Qty	TITLE
1	NC13-45-0016	1	FILLING CAP
2	NC13-45-0050	1	STRAINER TANK
3	NC13-45-0066	1	HEX. REDUCER 3/4" NPT FEM X 1 NPT MALE
4	NC01-76-0001	1	SIGHT GLASS 3/4 NPT
5	NC13-45-0109	1	ELBOW 45° 1/4 NPT FEM. X 1/4 NPT MALE
6	NC13-45-0015	1	HEX. CAP 1/2 NPTF MALE
7	22-57-0645	1	OIL TANK GROUP "STICKER INCLUDED"
8	22-13-0605	2	U BOLT
9	01-01-1660	4	WASHER SPACER
10	NC02-32-0014	4	LOCK WASHER ZINC 1/2"
11	NC02-07-0020	4	HEX. NUT ZINC 1/2-13

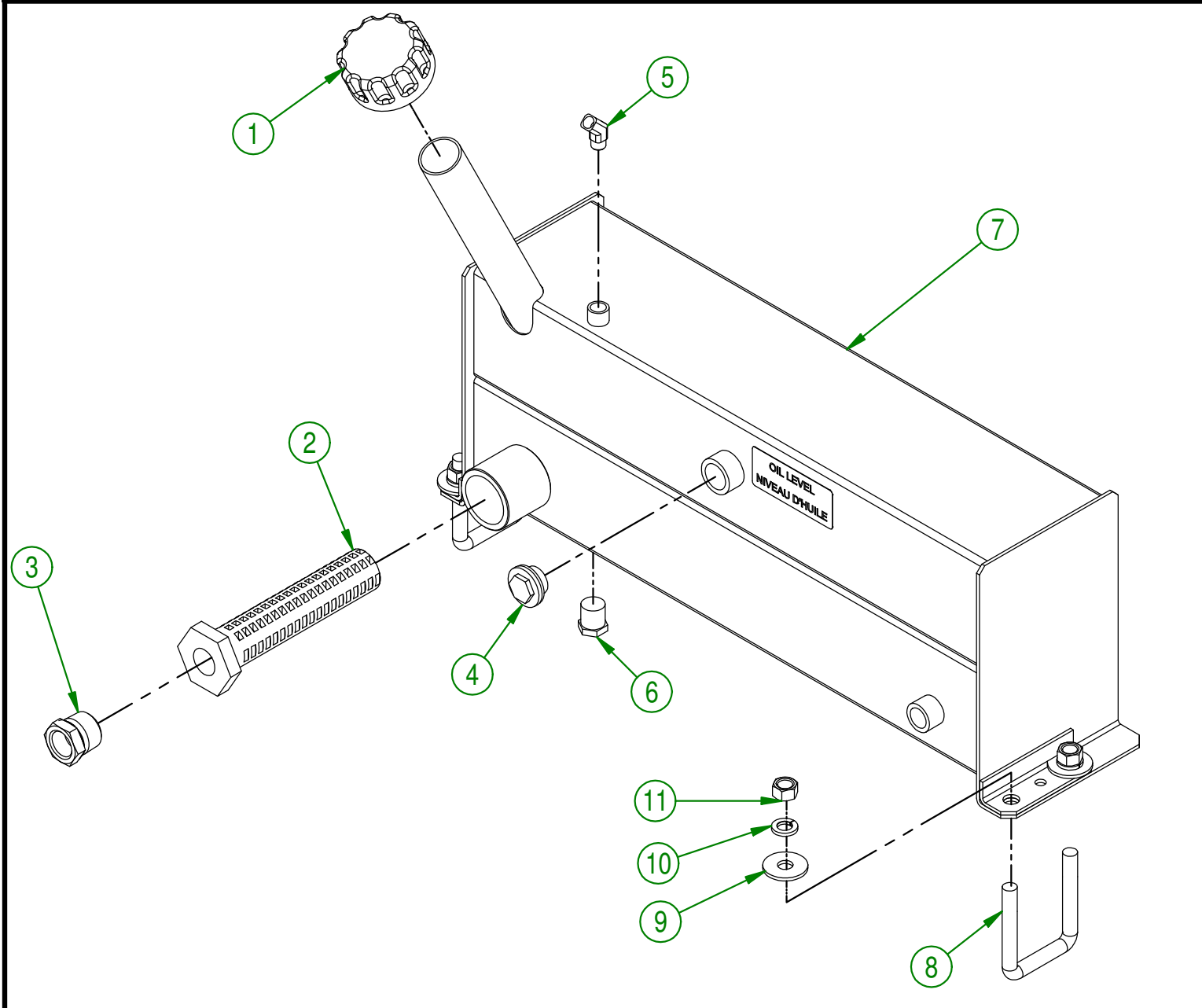

AGRIMETAL	
ASSEMBLY OIL TANK	
CREATION : 2016-10-14	ASSEMBLY : 22-57-0055
REVISION : 2018-05-04	AUTHOR : S.B. Page 42 de 67

#	PART #	Qty	TITLE
1	22-46-3750	1	GASKET
2	NC13-15-0034	2	RUBBER ABSORBER
3	NC02-32-0011	2	LOCK WASHER ZINC 5/16"
4	NC02-07-0017	2	HEX. NUT 5/16-18

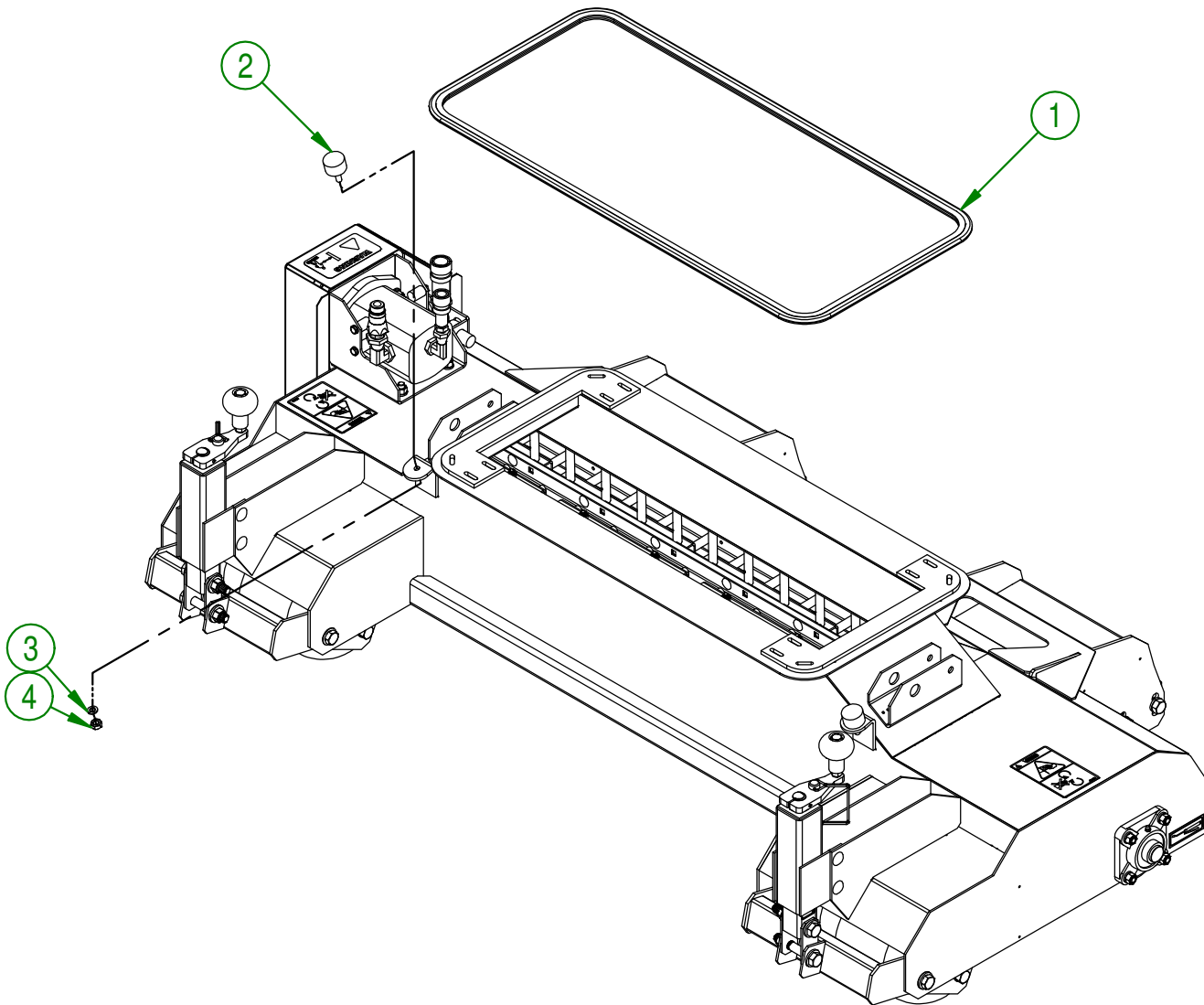
**AGRIMETAL**

PICK UP HEAD WITH ROTATIVE BRUSH (RUBBER FINGER)

CREATION : 2016-10-07

ASSEMBLY :

22-55-0046

REVISION : 2018-05-10

AUTHOR : S.B.

Page 43 de 67

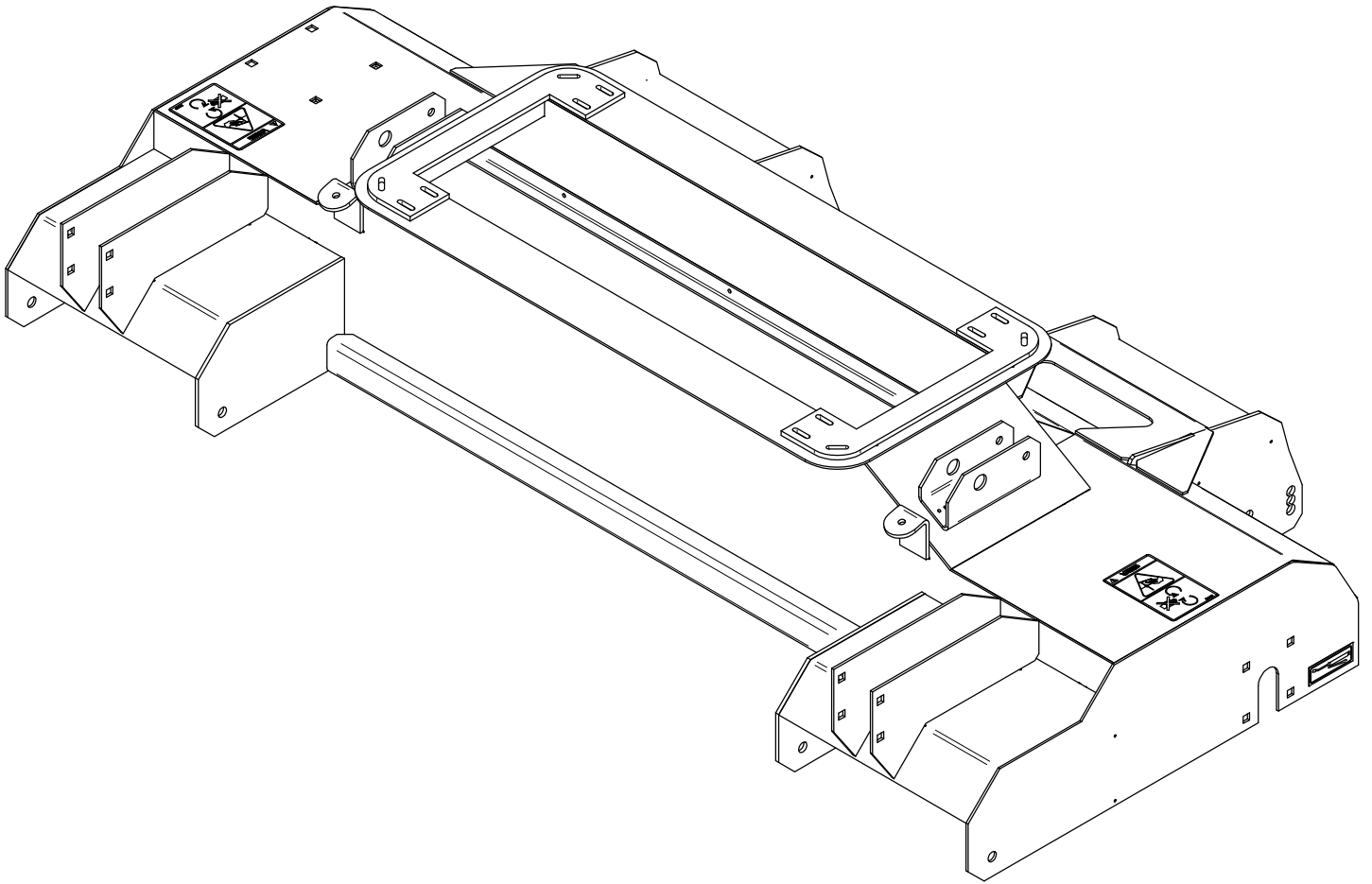

AGRIMETAL

PICK UP HEAD "STICKER INCLUDED"

CREATION : 14/11/17
REVISION : 25/05/18

ASSEMBLY : **22-57-0685**

AUTHOR : F.HÉLIE | Page 44 de 67

#	PART #	Qty	TITLE
1	22-50-0050	1	BRUSH ROTOR (FINGER) PTO & GAS
2	22-01-7540	20	RUBBER FINGER HOLDER
3	NC13-15-0347	80	RUBBER FINGER
4	NC01-04-0059	40	CARR. BOLT GR2 5/16-18 X 1 1/4
5	NC01-96-0010	40	NYLON NUT HEX. ZINC 5/16-18
6	22-03-0000	20	RUBBER FINGER STOP
7	22-50-0045	2	BEARING COVER
8	NC01-04-0110	8	CARR. BOLT GR2 ZINC 3/8-16 X 1 1/4"
9	NC02-32-0012	8	LOCK WASHER ZINC 3/8"
10	NC02-07-0018	8	HEX. NUT ZINC 3/8-16
11	22-55-0120	2	PILLOW BLOCK BEARING UCF 205-16 Ø 1"
12	01-41-0910	1	KEY
13	03-39-0155	1	PULLEY 2MA40 X 1" KW 1/4" 2SET SREW 5/16-18
14	NC01-17-0058	2	HEX. BOLT GR2 ZINC 5/16-18 X 3/4"

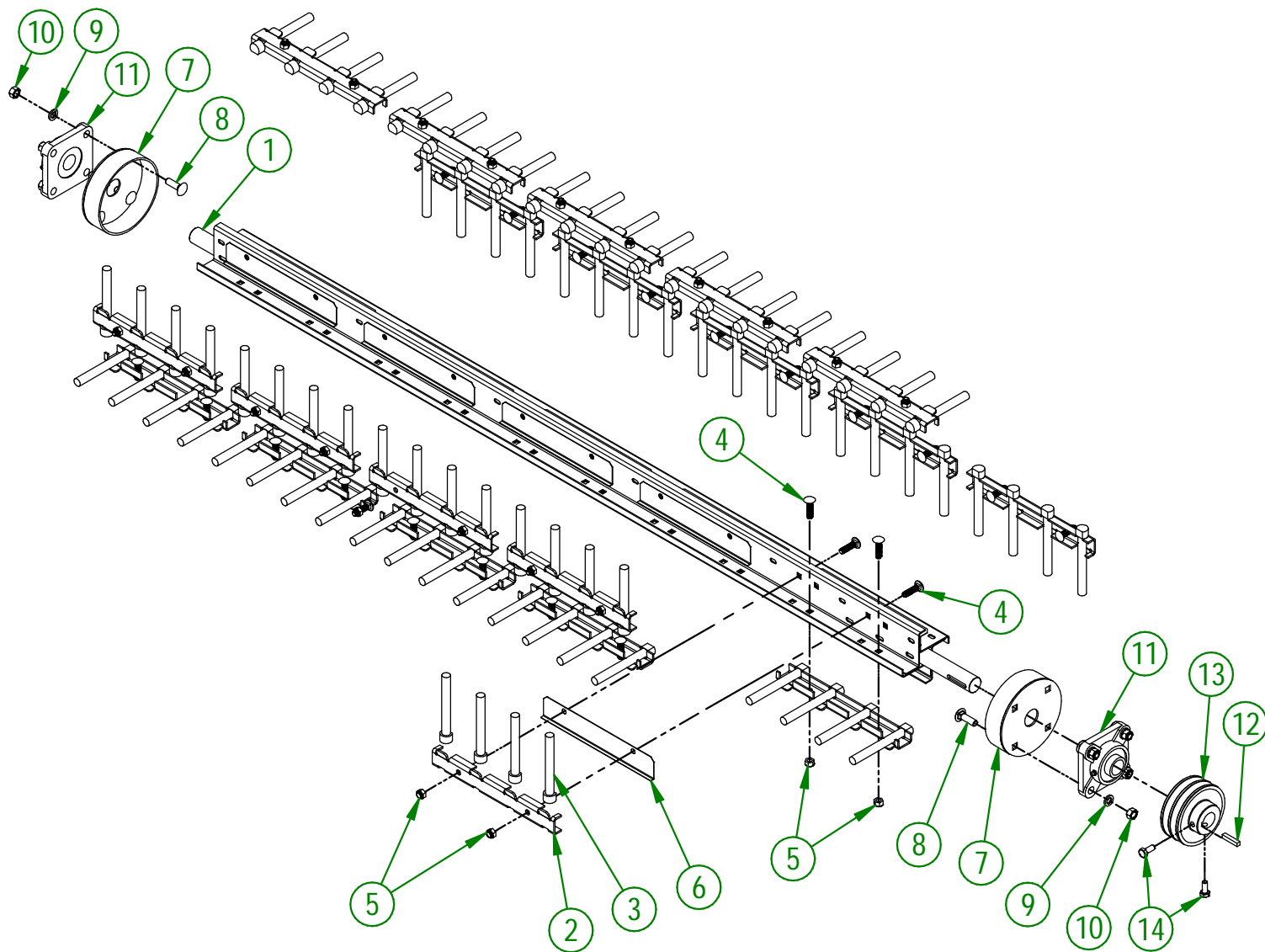

AGRIMETAL	
ROTARY BRUSH	
CREATION : 2016-10-07	ASSEMBLY : 22-57-0040
REVISION : 2022-10-24	AUTHOR : Dessin2

#	PART #	Qty	TITLE
1	22-46-3750	1	GASKET
2	NC13-15-0034	2	RUBBER ABSORBER
3	NC02-32-0011	2	LOCK WASHER ZINC 5/16"
4	NC02-07-0017	2	HEX. NUT 5/16-18

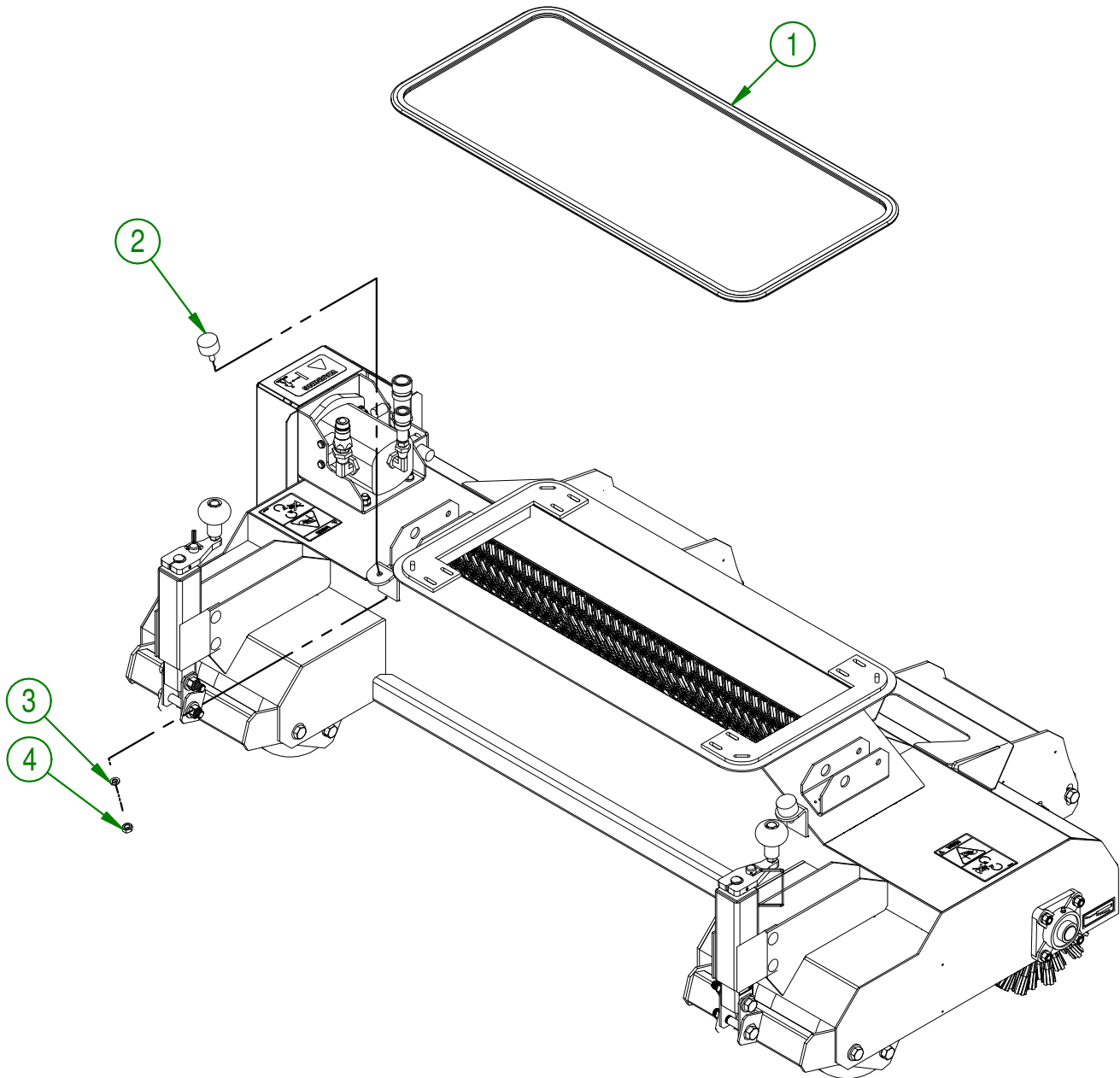
**AGRIMETAL****NYLON BRISTLE ROTARY BRUSH HEAD ASS'Y**

CREATION : 15/11/17
 REVISION : 10/05/18

ASSEMBLY : **22-55-0053**

AUTHOR : F.HÉLIE Page 46 de 67

#	PART #	Qty	TITLE
1	NC17-02-0291	1	NYLON BRISTLE BRUSH ASSY
2	01-41-0910	1	KEY
3	03-39-0155	1	PULLEY 2MA40 X 1" KW 1/4" 2SET SREW 5/16-18
4	22-01-7675	2	BEARING PROTECTOR (NYLON BRUSH)
5	22-55-0120	2	PILLOW BLOCK BEARING UCF 205-16 Ø 1"
6	NC01-04-0110	8	CARR. BOLT GR2 ZINC 3/8-16 X 1 1/4"
7	NC02-07-0018	8	HEX. NUT ZINC 3/8-16
8	NC02-32-0012	8	LOCK WASHER ZINC 3/8"
9	NC01-17-0058	2	HEX. BOLT GR2 ZINC 5/16-18 X 3/4"

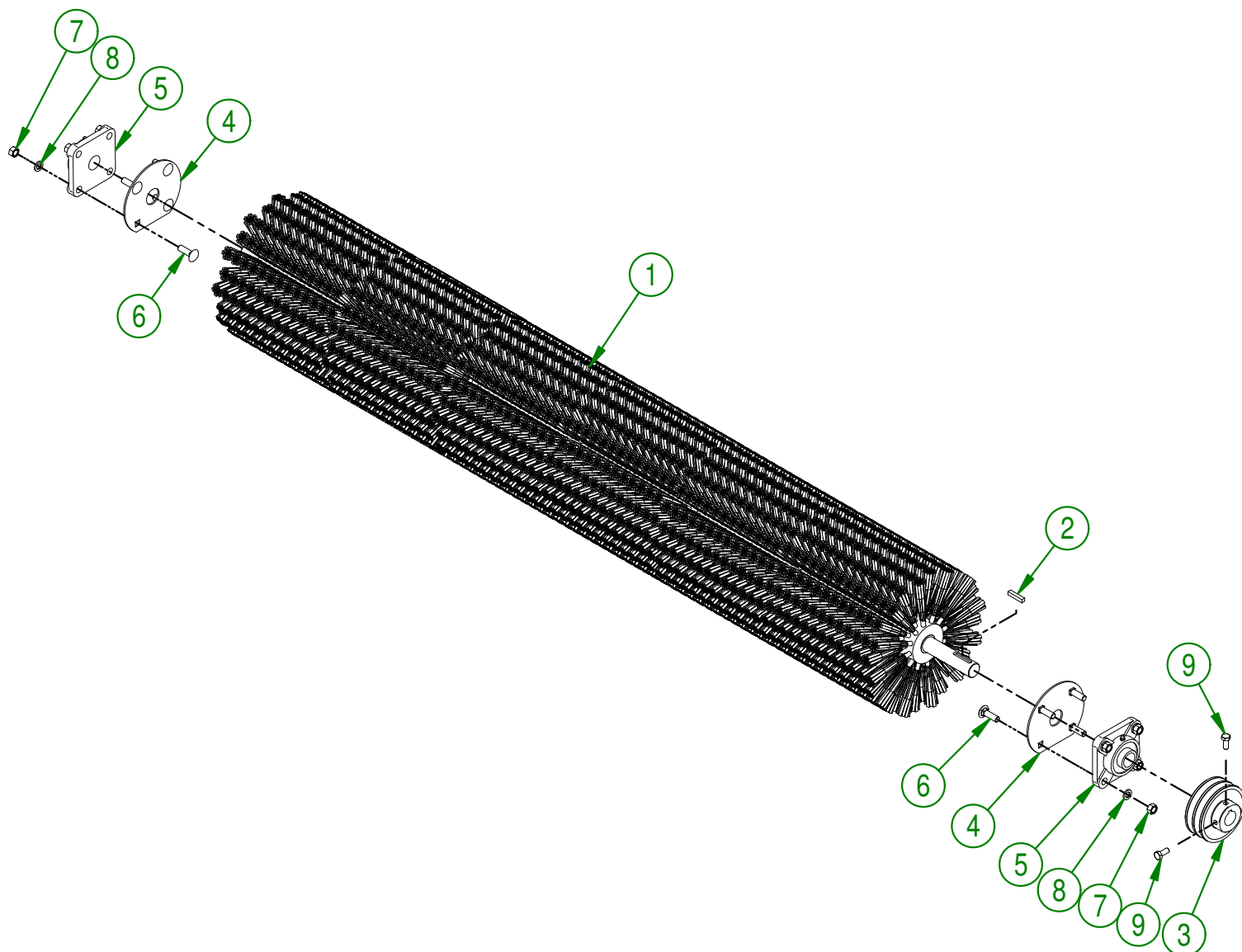

AGRIMETAL	
ASSEMBLY NYLON BRUSH	
CREATION : 20/09/17	ASSEMBLY : 22-57-0044
REVISION : 16/01/19	AUTHOR : F.HÉLIE Page 47 de 67

#	PART #	Qty	TITLE
1	22-46-3750	1	GASKET
2	NC13-15-0034	2	RUBBER ABSORBER
3	NC02-32-0011	2	LOCK WASHER ZINC 5/16"
4	NC02-07-0017	2	HEX. NUT 5/16-18

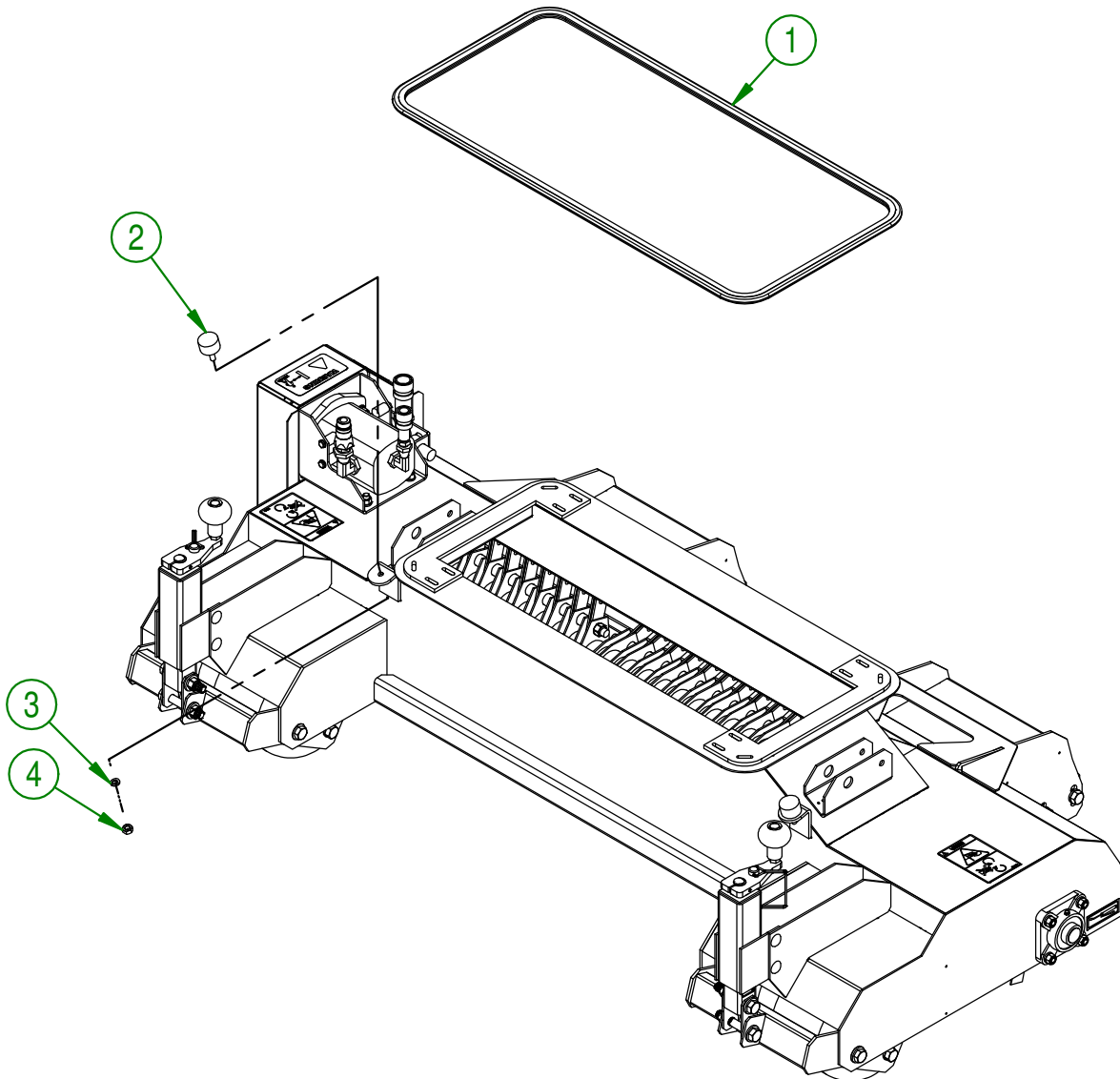
**AGRIMETAL****DETHATCHING HEAD WITH KNIVES SYSTEM ASS'Y**

CREATION : 18/09/17
 REVISION : 10/05/18

ASSEMBLY : **22-55-0051**

AUTHOR : F.HÉLIE Page 48 de 67

#	PART #	Qty	TITLE
1	01-41-0910	1	KEY WAY
2	03-39-0155	1	PULLEY 2MA40 X 1" KW 1/4" 2SET SREW 5/16-18
3	22-50-1020	2	BEARING PROTECTOR (HAMMER ROTOR)
4	22-55-0120	2	PILLOW BLOCK BEARING UCF 205-16 Ø 1"
5	NC01-04-0110	8	CARR. BOLT GR2 ZINC 3/8-16 X 1 1/4"
6	NC02-07-0018	8	HEX. NUT ZINC 3/8-16
7	NC02-32-0012	8	LOCK WASHER ZINC 3/8"
8	NC01-17-0058	2	HEX. BOLT GR2 ZINC 5/16-18 X 3/4"

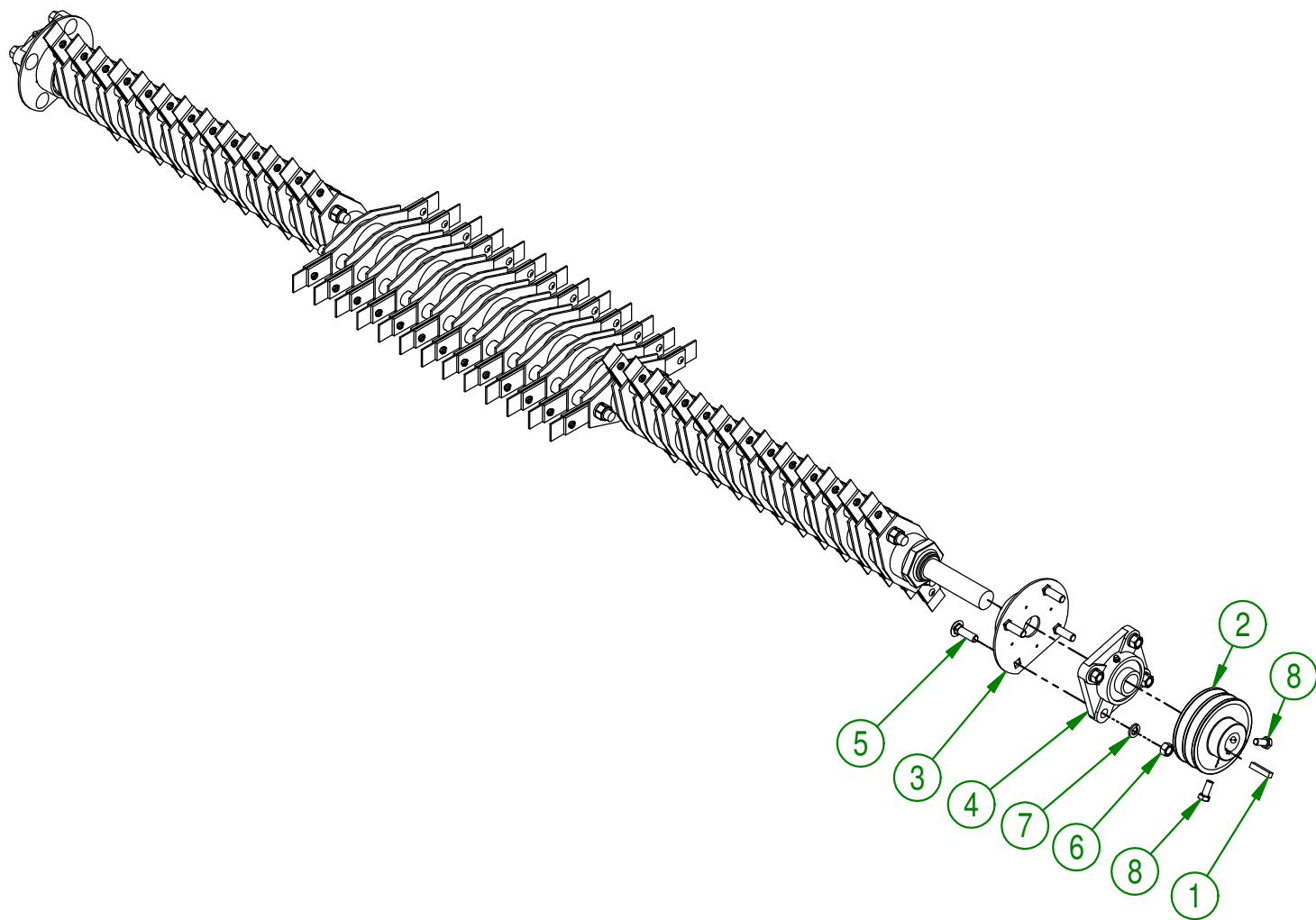

AGRIMETAL	
ASSEMBLY ROTARY BRUSH (HAMMER)	
CREATION : 18/09/17	ASSEMBLY : 22-57-0043
REVISION : 09/05/18	AUTHOR : F.HÉLIE Page 49 de 67

#	PART #	Qty	TITLE
1	22-25-2403	1	ROTOR SHAFT
2	22-09-0805	2	HAMMER SUPPORT SHIM (TIP)
3	22-01-7691	78	HAMMER SUPPORT
4	22-20-0401	6	HAMMER PIVOT
5	22-09-0810	39	HAMMER SUPPORT SHIM
6	22-09-0800	38	HAMMER SUPPORT SHIM
7	NC01-96-0014	12	NYLON-INSERT LOCKNUT ZINC 1/2-13
8	NC01-98-0021	2	HEX. BLOC NUT 1 1/4-18
9	22-55-0355	78	ROTOR HAMMER ASS'Y.

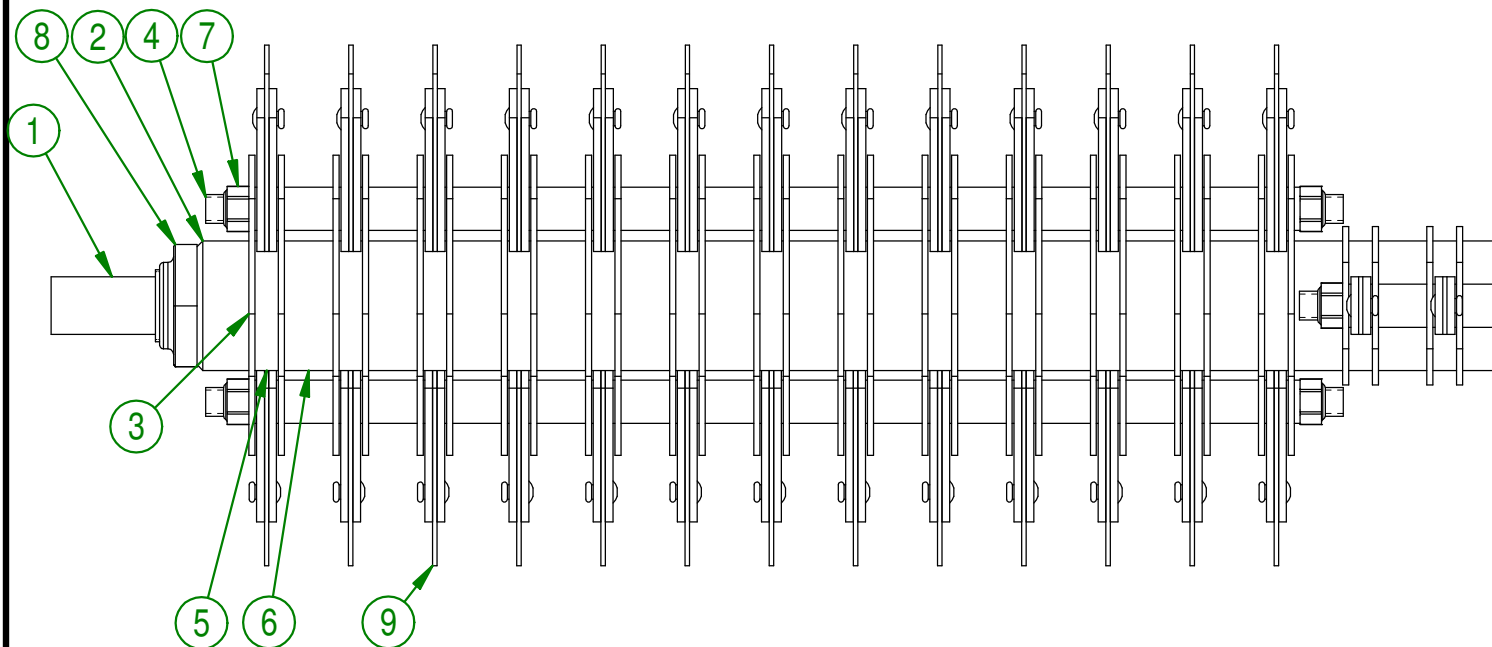
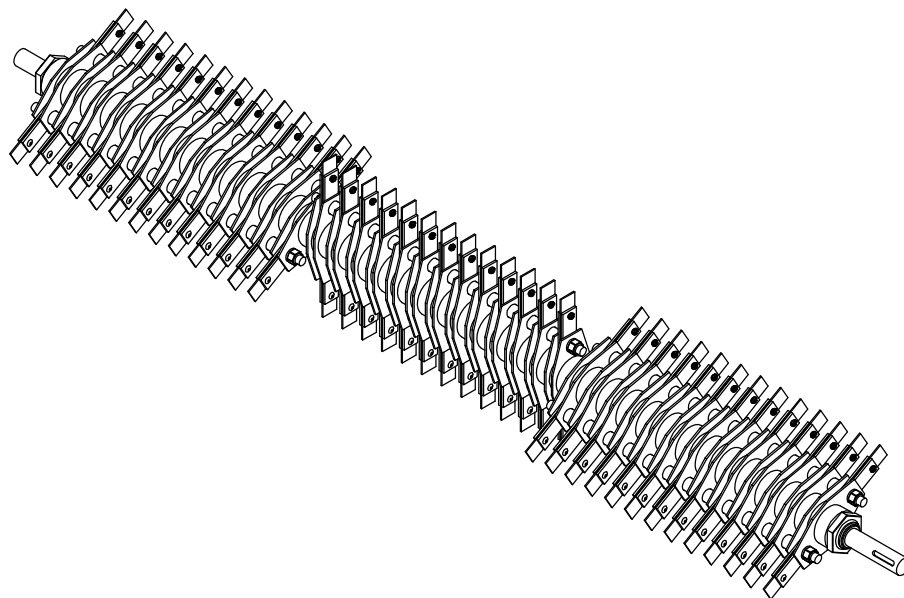

AGRIMETAL	
ROTARY BRUSH (HAMMER) ASS'Y	
CREATION : 20/03/17	ASSEMBLY : 22-55-0019
REVISION : 15/11/17	AUTHOR : F.HÉLIE Page 50 de 67

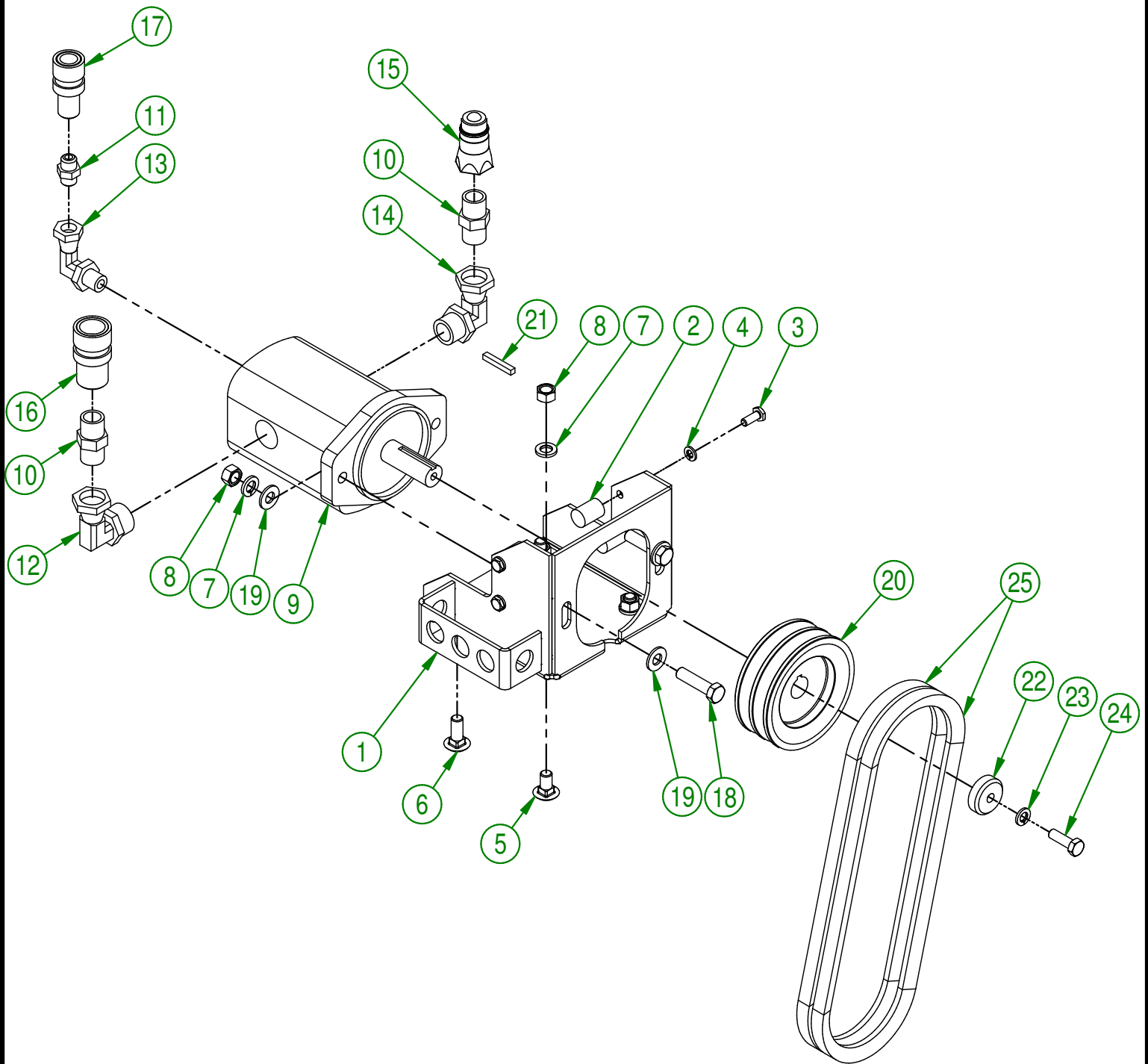

USE THESE PIECES ONLY IF YOUR SERIAL
NUMBER IS AFFECTED:

#40420 AND UNDER

AGRIMETAL	
HYDRAULIC MOTOR MOUNT	
CREATION : 07-10-2016	ASSEMBLY : 22-57-0030
REVISION : 27-05-2021	AUTHOR : S.B.

#	PART #	Qty	TITLE
1	22-50-0010	1	HYDRAULIC MOTOR SUPPORT
2	22-21-0030	4	HYDRAULIC MOTOR STOPPER
3	NC01-29-0003	4	HEX. BOLT GR5 ZINC 1/4-28 X 5/8"
4	NC02-32-0010	4	LOCK WASHER ZINC 1/4"
5	NC01-04-0107	2	CARR. BOLT GR2 ZINC 3/8-16 X 3/4"
6	NC01-04-0109	2	CARR. BOLT GR2 ZINC 3/8-16 X 1"
7	NC02-32-0012	6	LOCK WASHER ZINC 3/8"
8	NC02-07-0018	6	HEX. NUT ZINC 3/8-16
9	NC14-45-0022	1	HYDRAULIC MOTOR
10	NC13-45-0029	2	HEX. NIPPLE 1/2 MALE NPT X 1/2 MALE NPT
11	NC13-45-0114	1	HEX. NIPPLE 1/4 MALE NPT X 1/4 MALE NPT
12	NC13-45-0113	1	ELBOW 90° 1 1/16-12 MALE SAE12 O RING X 1/2 FEM. TOUR. NPT
13	NC13-45-0108	1	ELBOW 90° 9/16-18 MALE SAE6 O RING
14	NC13-45-0028	1	ELBOW 90° 7/8-14 MALE SAE O RING X 1/2 FEM NPT
15	NC13-45-0014	1	QUICK COUPLER 1/2-14 NPTF
16	NC13-45-0047	1	QUICK COUPLER FEMALE 1/2-14 NPTF
17	NC13-45-0111	1	QUICK COUPLEUR FEMALE X FEMALE NPTF 1/4-18
18	NC01-17-0116	2	HEX. BOLT GR2 ZINC 3/8-16 X 1 1/2"
19	01-01-2485	4	FLAT WASHER 14 GA X 13/16"OD X 25/64" ID
20	NC14-62-0162	1	2MA40 PULLEY X Ø3/4" KW 3/16" 2SS
21	01-41-0905	1	SQUARE KEY 3/16" X 1 1/4"TL
22	22-21-0020	1	PULLEY RETAINING CAP
23	NC02-32-0011	1	LOCK WASHER ZINC 5/16"
24	NC01-17-0060	1	HEX. BOLT GR2 ZINC 5/16-18 X 1"
25	NC14-25-0254	2	V BELT 1/2 A-27

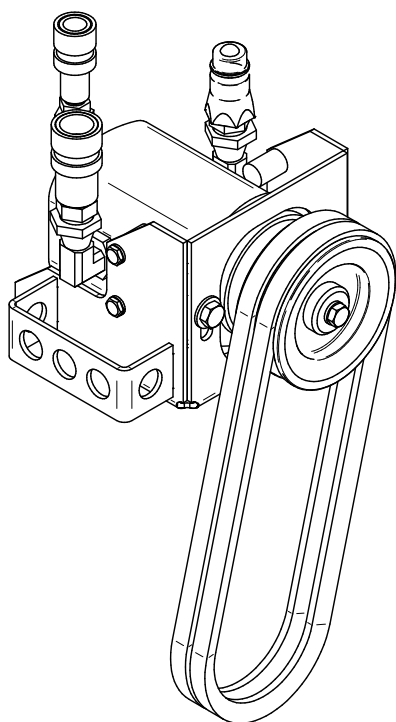

AGRIMETAL	
HYDRAULIC MOTOR MOUNT	
CREATION : 07-10-2016	ASSEMBLY : 22-57-0030
REVISION : 27-05-2021	AUTHOR : S.B.

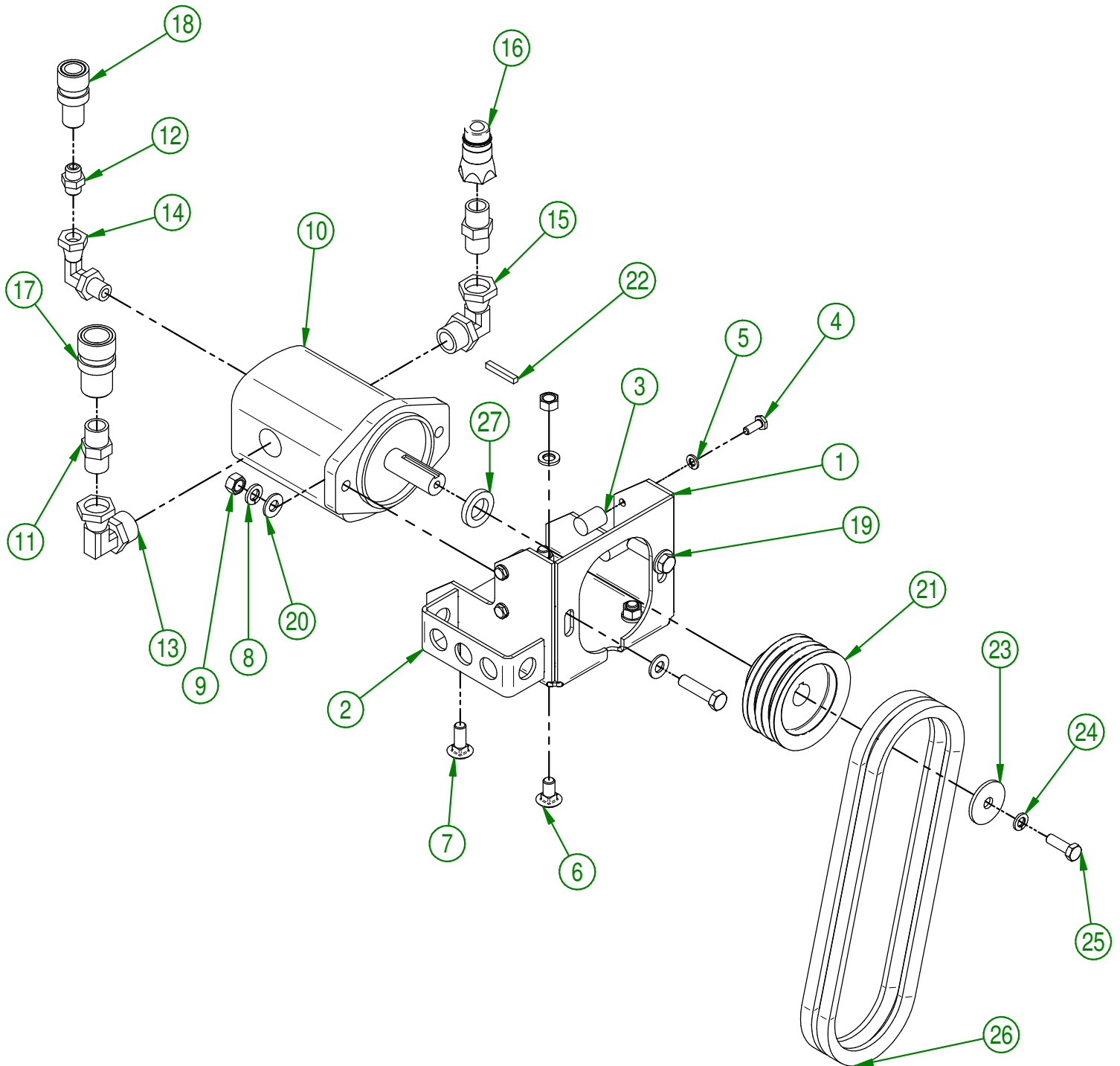

USE THESE PIECES ONLY IF YOUR SERIAL
NUMBER IS AFFECTED:

#40421 AND ABOVE

AGRIMETAL	
HYDRAULIC MOTOR SUPPORT GROUP	
CREATION : 25/05/21	ASSEMBLY : 22-57-0031
REVISION : 09/06/21	AUTHOR : G.HUBERDEAU

22-57-0031

#	PART #	Qty	TITLE
1	22-01-1035	1	HYDRAULIC MOTOR SUPPORT
2	22-01-1030	1	BELT TENSIONER BRACKET
3	22-21-0030	4	HYDRAULIC MOTOR STOPPER
4	NC01-29-0003	4	HEX. BOLT GR5 ZINC 1/4-28 X 5/8"
5	NC02-32-0010	4	LOCK WASHER ZINC 1/4"
6	NC01-04-0107	2	CARR. BOLT GR2 ZINC 3/8-16 X 3/4"
7	NC01-04-0109	2	CARR. BOLT GR2 ZINC 3/8-16 X 1"
8	NC02-32-0012	6	LOCK WASHER ZINC 3/8"
9	NC02-07-0018	6	HEX. NUT ZINC 3/8-16
10	NC14-45-0022	1	HYDRAULIC MOTOR
11	NC13-45-0029	2	HEX. NIPPLE 1/2 MALE NPT X 1/2 MALE NPT
12	NC13-45-0114	1	HEX. NIPPLE 1/4 MALE NPT X 1/4 MALE NPT
13	NC13-45-0113	1	ELBOW 90° 1/16-12 MALE SAE12 O RING X 1/2 FEM. TOUR. NPT
14	NC13-45-0108	1	ELBOW 90° 9/16-18 MALE SAE6 O RING
15	NC13-45-0028	1	ELBOW 90° 7/8-14 MALE SAE O RING X 1/2 FEM NPT
16	NC13-45-0014	1	QUICK COUPLER 1/2-14 NPTF
17	NC13-45-0047	1	QUICK COUPLER FEMALE 1/2-14 NPTF
18	NC13-45-0111	1	QUICK COUPLEUR FEMALE X FEMALE NPTF 1/4-18
19	NC01-17-0116	2	HEX. BOLT GR2 ZINC 3/8-16 X 1 1/2"
20	01-01-2485	4	FLAT WASHER 14 GA X 13/16"OD X 25/64" ID
21	NC14-62-0232	1	2MA35 PULLEY X Ø3/4" KW 3/16" 2SS
22	01-41-0905	1	SQUARE KEY 3/16" X 1 1/4"TL
23	01-33-0010	1	WASHER
24	NC02-32-0011	1	LOCK WASHER ZINC 5/16"
25	NC01-17-0060	1	HEX. BOLT GR2 ZINC 5/16-18 X 1"
26	NC14-25-5371	2	V BELT 1/2 COGGED RAW EDGE AX-26
27	22-09-0000	1	

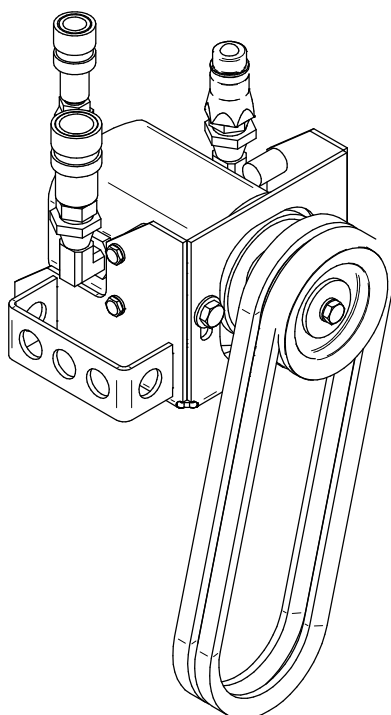
**AGRIMETAL**

HYDRAULIC MOTOR SUPPORT GROUP

CREATION : 25/05/21

REVISION : 09/06/21

ASSEMBLY : **22-57-0031**

AUTHOR : G.HUBERDEAU

#	PART #	Qty	TITLE
1	22-50-0030	1	BELT TIGHTENER PIVOT
2	22-41-0080	2	TENSION BELT BUSHING
3	NC02-44-0102	2	SOCKET HEAD CAP SCREW 5/16-18 X 5/16"
4	22-21-0005	1	TENSION PULLEY
5	NC14-75-0068	1	BALL BEARING 99502H
6	NC01-64-0142	1	SNAP RING HOLE I 3/8"
7	22-21-0025	1	IDLER PULLEY BUSHING
8	NC01-17-0117	1	HEX. BOLT GR2 ZINC 3/8-16 X I 3/4"
9	01-01-2485	1	FLAT WASHER
10	NC02-32-0012	2	LOCK WASHER ZINC 3/8"
11	NC02-07-0018	3	HEX. NUT ZINC 3/8-16
12	NC13-85-0008	1	GALVANISED SPRING
13	NC01-17-0116	1	HEX. BOLT GR2 ZINC 3/8-16 X I 1/2"

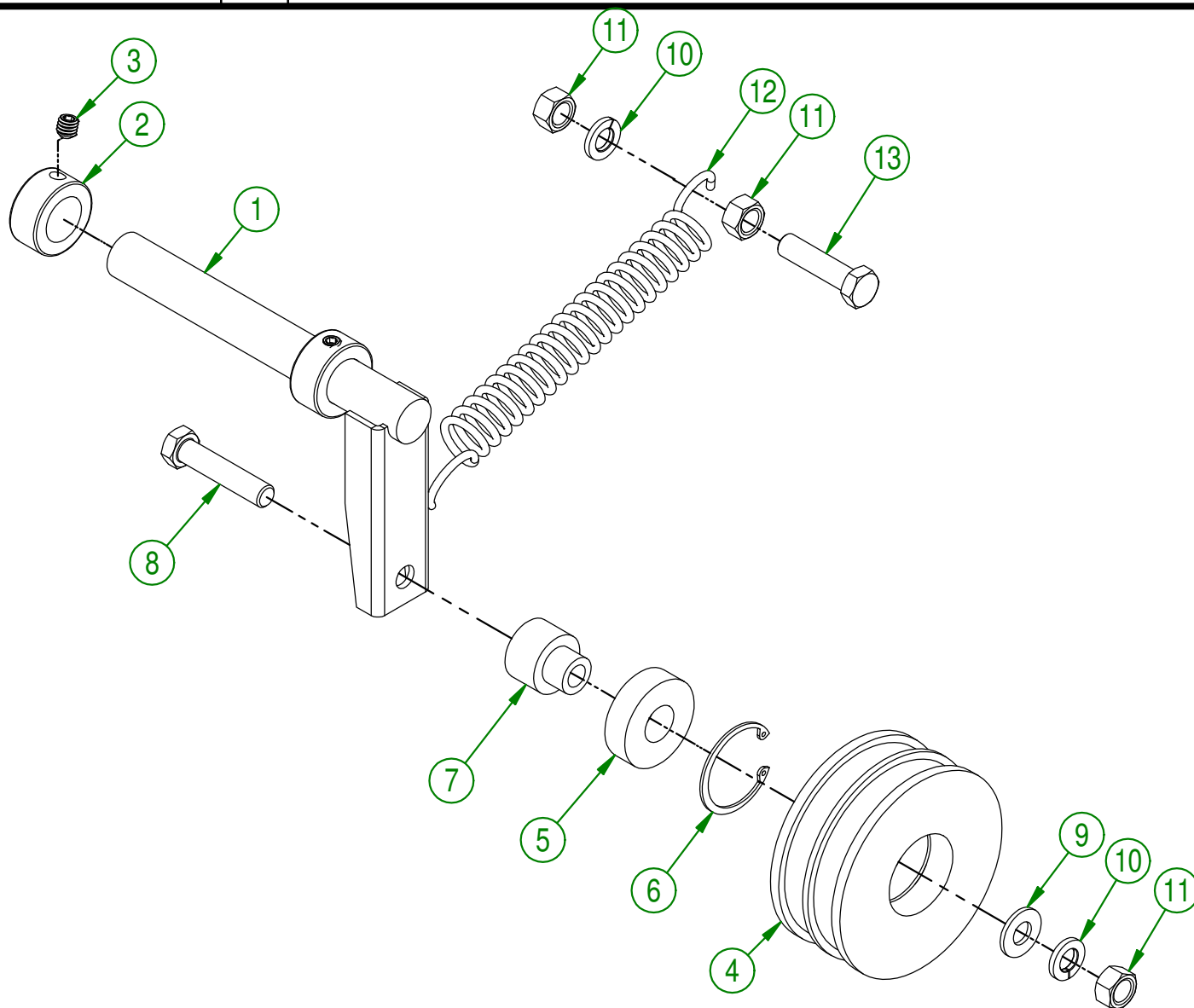

AGRIMETAL	
BELT TENSIONNEUR	
CREATION : 2016-10-07	ASSEMBLY : 22-57-0045
REVISION : 2018-05-04	AUTHOR : S.B. Page 53 de 67

#	PART #	Qty	TITLE
1	22-57-0680	1	BELT GUARD (STICKER INCLUDED)
2	01-01-2485	3	FLAT WASHER
3	NC02-32-0012	3	LOCK WASHER ZINC 3/8"
4	NC02-07-0018	3	HEX. NUT ZINC 3/8-16

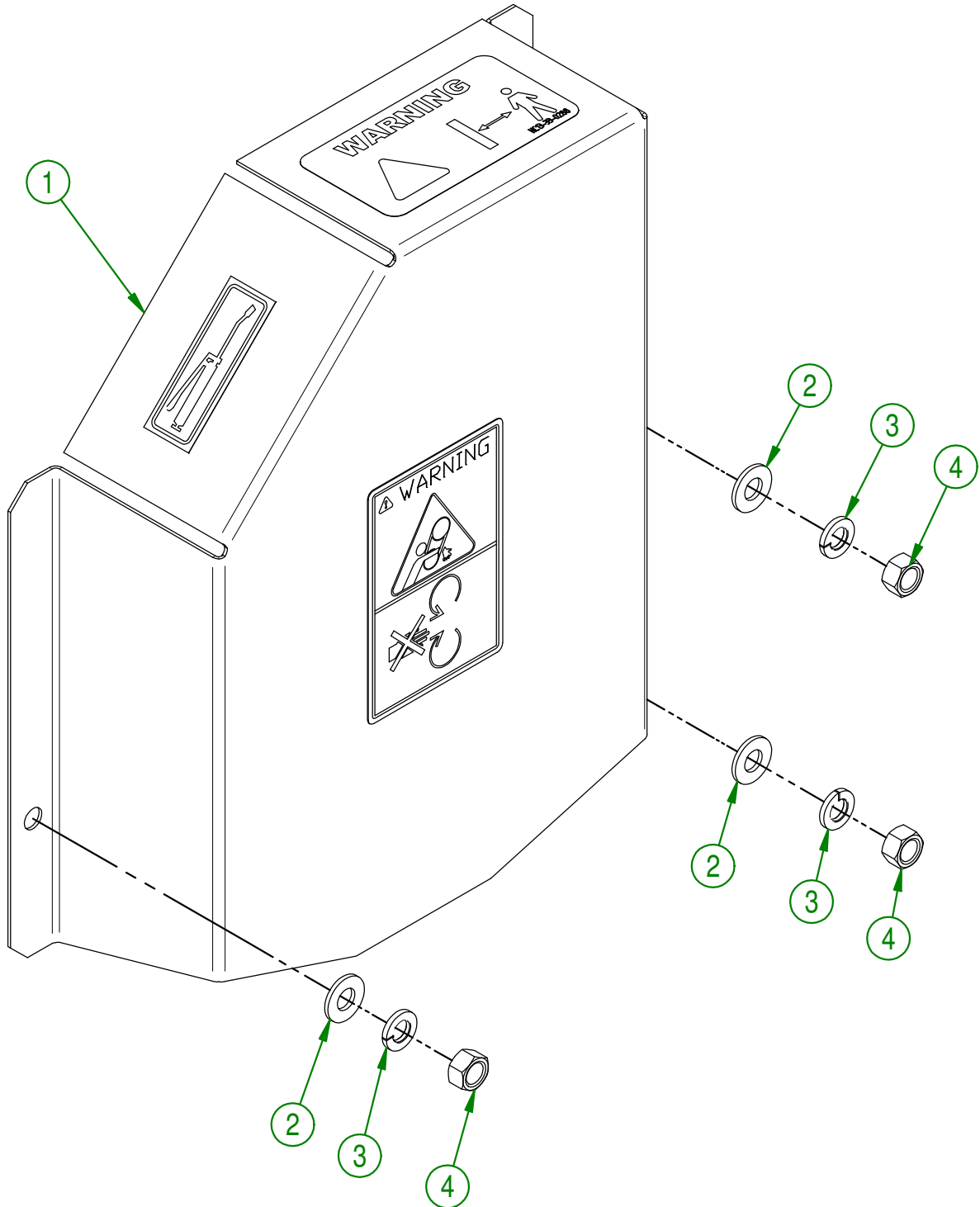

AGRIMETAL		
BELT GUARD GROUP		
CREATION : 2016-10-19	ASSEMBLY :	22-57-0037
REVISION : 2018-05-04	AUTHOR : S.B.	Page 54 de 67

28-57-0017

#	PART #	Qty	TITLE
1	28-57-0015	1	ADJUSTABLE JACK GROUP (LEFT)
2	28-57-0016	1	ADJUSTABLE JACK GROUP (RIGHT)
3	28-01-1035	4	UNION BRACKET
4	NC02-25-0011	8	WASHER SAE ZINC 17/32 ID
5	NC01-17-0253	2	HEX. BOLT GR2 ZINC 1/2-13 X 2 1/2"
6	NC01-17-0255	2	HEX. BOLT GR2 ZINC 1/2-13 X 3"
7	NC01-93-0014	4	LOCK NUT ZINC 1/2-13
8	NC01-69-1300	2	LOCKING PIN 1/4" DIA. X 2 1/2" GRIP X 1 5/8" H AC ZINC

28-57-0015 / 28-57-0016

#	PART #	Qty	TITLE
8	28-50-0070	1	MANUAL ACTUATOR MOBILE SQUARE TUBE
9	28-50-0075	1	MANUAL ACTUATOR FIXED TUBE
10	28-42-0105	2	TRUST WASHER
11	01-33-0035	2	FLAT WASHER Ø 1 1/4" X Ø 49/64" X 10 GA.
12	NC01-69-0419	2	SPRING TIGHTENER PIN ZINC 3/16 XI"
13	28-04-0600	1	ROTATING PLATE (MANUAL ACTUATOR)
14	NC17-46-0018	1	HANDLE KNOB
15	NC01-17-0122	1	HEX. BOLT GR2 ZINC 3/8-16 X 3"
16	01-01-2485	1	FLAT WASHER 14 GA X 13/16"OD X 25/64" ID
17	NC01-96-0011	1	NYLON NUT 3/8-16
18	NC01-69-0429	1	SPRING PIN ZINC 3/16" X 1 3/4"
19	28-31-1150	1	MANUAL ACTUATOR ACME ROD
20	NC01-04-0107	4	CARR. BOLT GR2 ZINC 3/8-16 X 3/4"
21	NC02-32-0012	4	LOCK WASHER ZINC 3/8"
22	NC02-07-0018	4	HEX. NUT ZINC 3/8-16

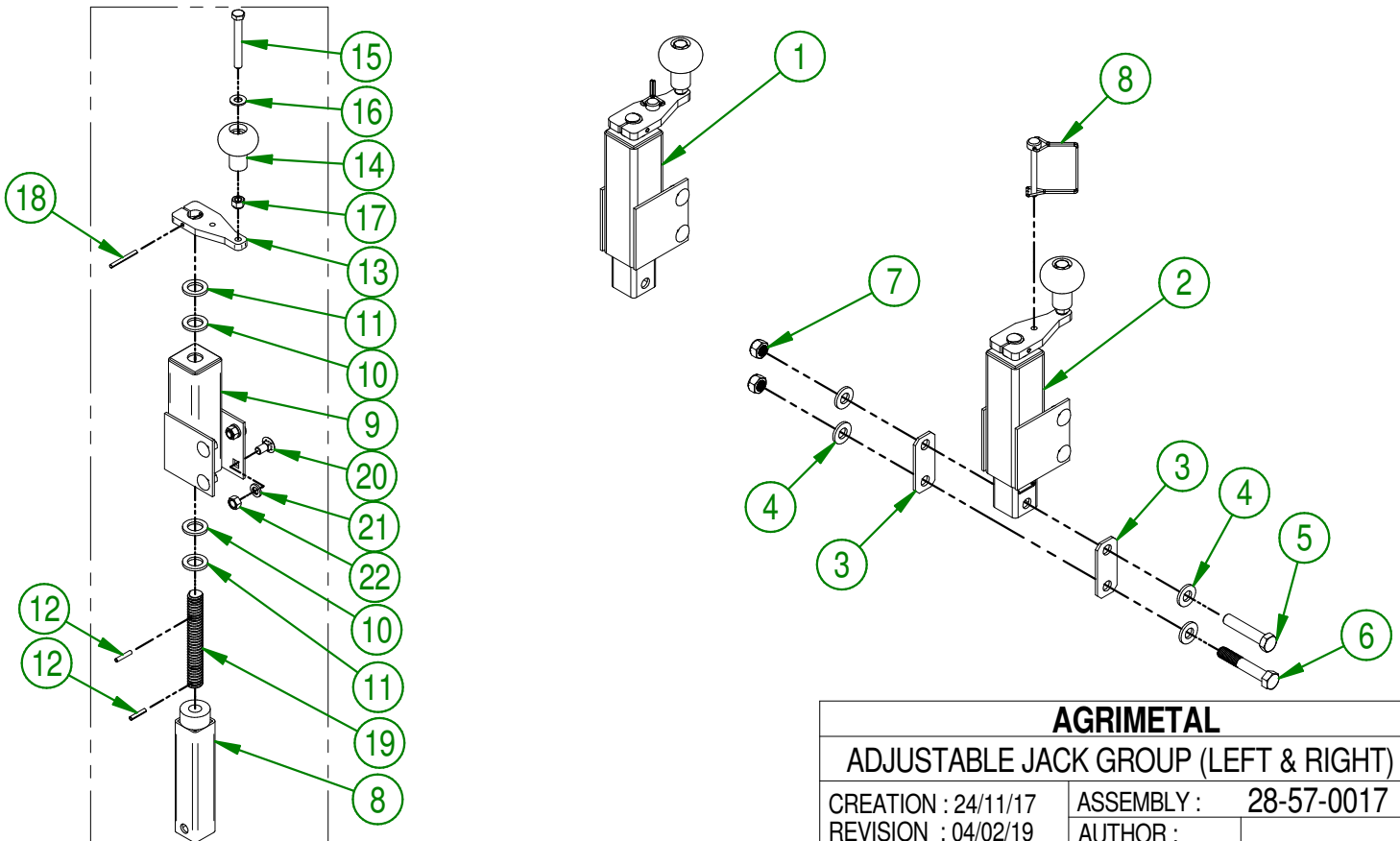

AGRIMETAL	
ADJUSTABLE JACK GROUP (LEFT & RIGHT)	
CREATION : 24/11/17	ASSEMBLY : 28-57-0017
REVISION : 04/02/19	AUTHOR :

#	PART #	Qty	TITLE
1	22-50-0015	1	TRACTION ARM (PTO & GAS)
2	22-13-1600	2	ATTACHMENT ARM PIN
3	NC01-63-0026	2	COTTER PIN ZC 5/32" X 3"

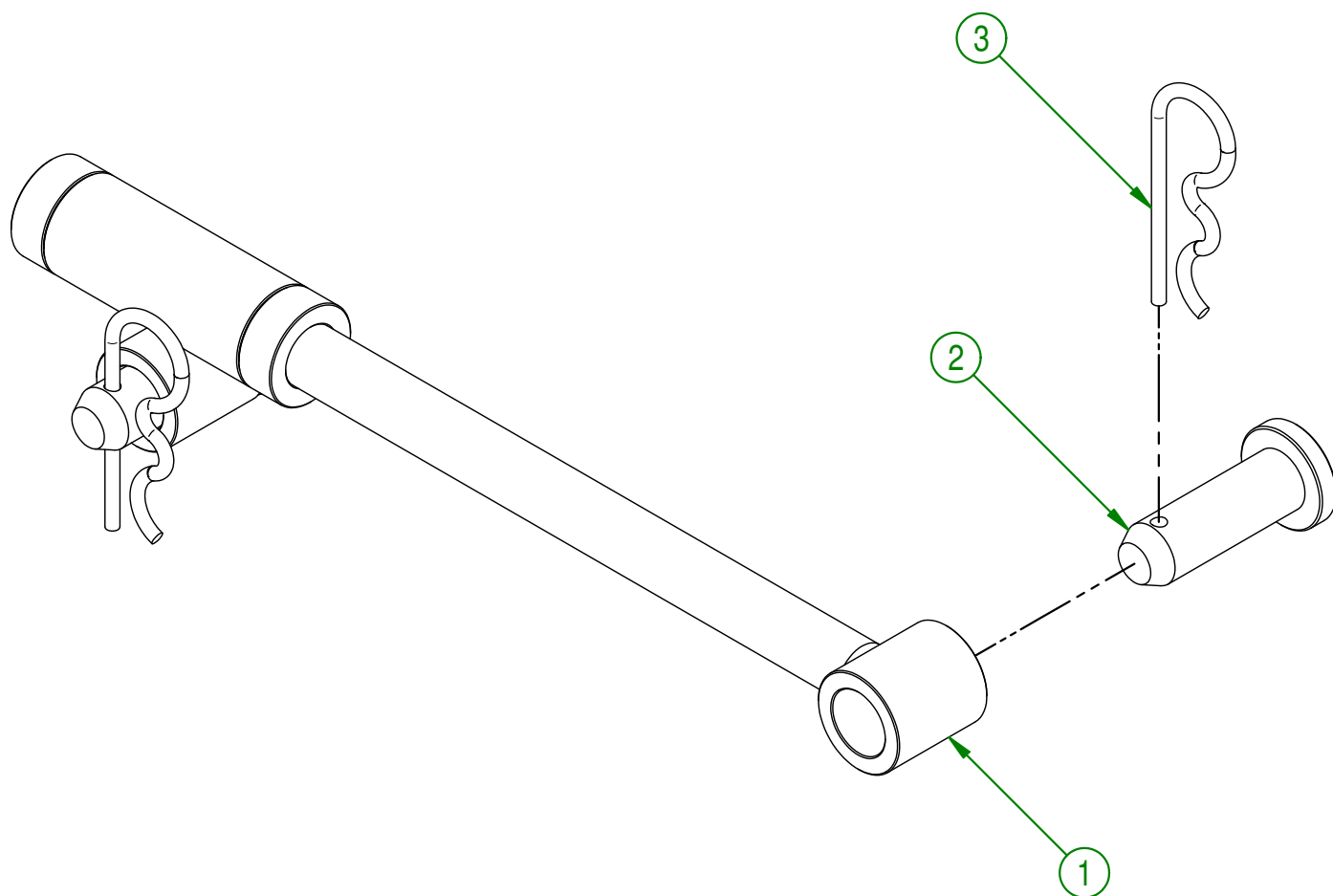

AGRIMETAL	
PICK UP HEAD ARM	
CREATION : 17/11/17	ASSEMBLY : 22-57-0195
REVISION : 14/11/18	AUTHOR : F.HÉLIE Page 56 de 67

22-57-0270

#	PART #	Qty	TITLE
1	22-55-0360	1	ROLLER Ø 6"
2	22-13-1430	1	REAR ROLLER SHAFT
3	28-42-0120	2	SPACER
4	NC02-32-0014	4	LOCK WASHER ZINC 1/2"
5	NC01-17-0247	4	HEX. BOLT GR2 ZINC 1/2-13 X 1"
6	22-50-0190	1	ROLLER SCRAPER

22-55-0360

#	PART #	Qty	TITLE
7	NC14-75-0070	2	6205-2RS BEARING
8	22-46-0000	1	ROLLER

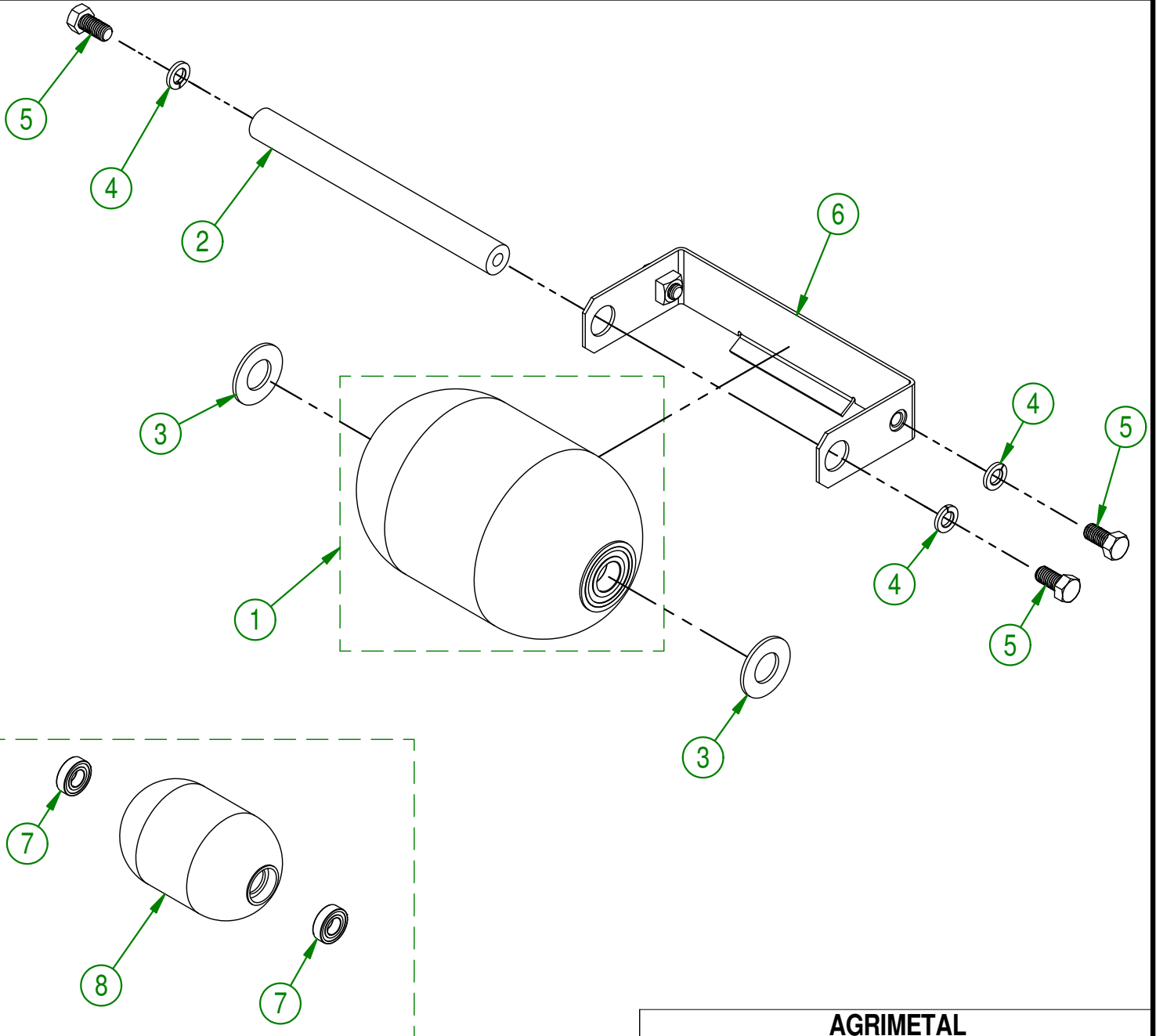

AGRIMETAL		
REAR ROLLER GROUP		
CREATION : 07-10-2016	ASSEMBLY :	22-57-0270
REVISION : 01-02-2019	AUTHOR :	Page 57 de 67

22-57-0280

#	PART #	Qty	TITLE
1	22-55-0360	1	ROLLER Ø 6"
2	22-13-1425	1	FRONT ROLLER SHAFT
3	28-42-0120	2	SPACER
4	NC02-32-0014	4	LOCK WASHER ZINC 1/2"
5	NC01-17-0247	2	HEX. BOLT GR2 ZINC 1/2-13 X 1"
6	22-50-0180	1	ROLL HOLDER ADJUSTABLE
7	28-13-2040	2	PIVOT ROLLER
8	01-01-1660	2	WASHER SPACER
9	NC02-25-0011	2	WASHER SAE ZINC 17/32 ID
10	NC01-17-0251	2	HEX. BOLT GR2 ZINC 1/2-13 X 2"
11	NC02-07-0020	2	HEX. NUT ZINC 1/2-13

22-55-0360

#	PART #	Qty	TITLE
12	NC14-75-0070	2	6205-2RS BEARING
13	22-46-0000	1	ROLLER

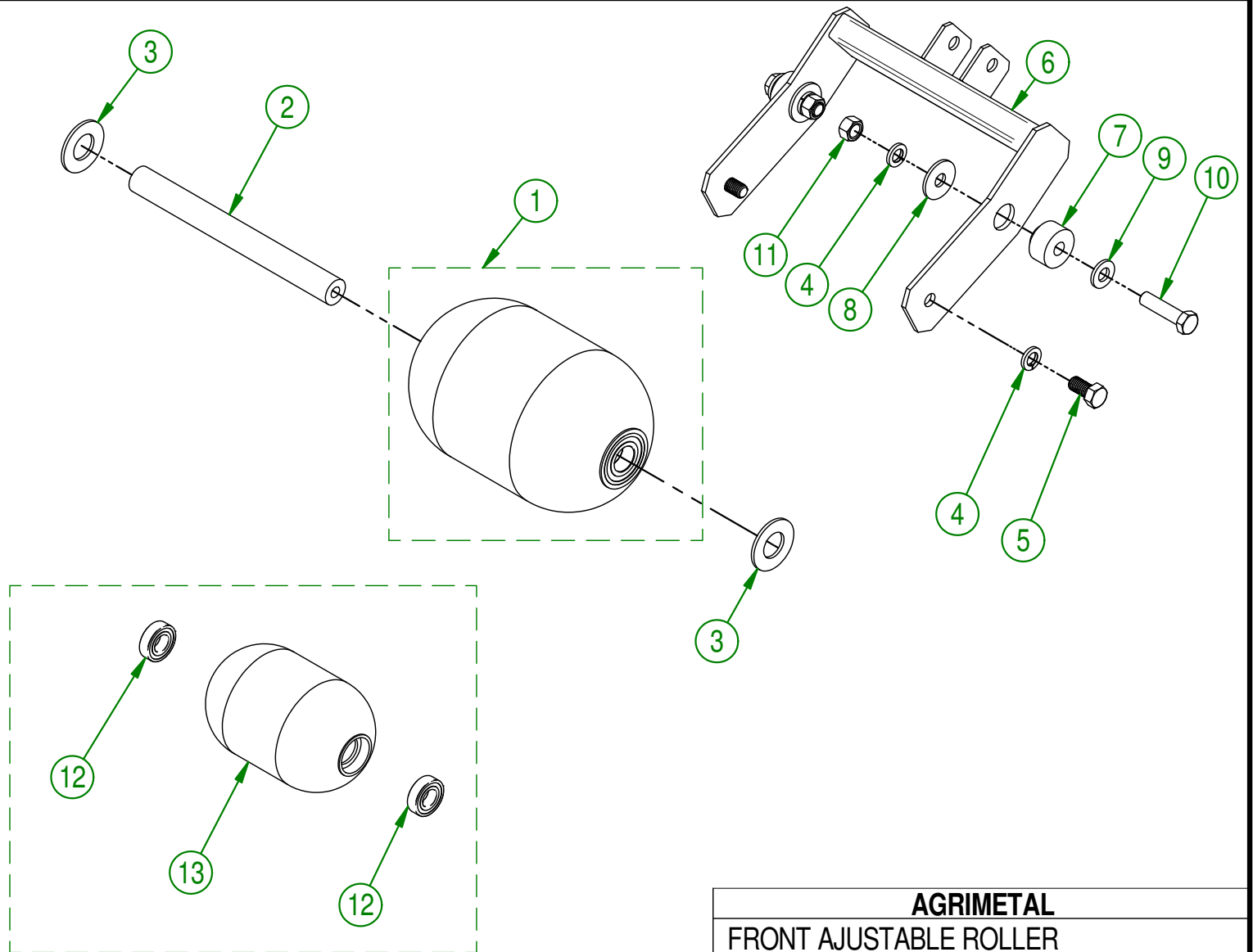

AGRIMETAL		
FRONT AJUSTABLE ROLLER		
CREATION : 07-10-2016	ASSEMBLY :	22-57-0280
REVISION : 15-11-2018	AUTHOR :	Page 58 de 67

#	PART #	Qty	TITLE
1	NCI3-25-0284	1	KRALOY TERMINAL BOX 2" X 2 13/16" X 4 9/16"
2	NCI3-25-0285	1	KRALOY BOX COVER 2 13/16" X 4 9/16"
3	16-55-0290	2	LIGHT SUPPORT ASSY
4	NCI3-25-0278	1	FIXING LIGHT REGISTRATION PLATE
5	22-55-0210	1	ASSEMBLY TRAILER CABLE CONNECTION 3 SPRIGS (RIGHT)
6	22-55-0215	1	ASSEMBLY TRAILER CABLE CONNECTION 3 PRIGS. (LEFT)
7	16-55-0043	1	TRAILER CONNECTION 4 SPRIGS
8	22-55-0220	1	ASSEMBLY TRAILER CABLE CONNECTION 4 SPRIGS
9	NC02-42-0086	2	SQUARE DRIVE SCREW #12 X 3/4"
10	NC01-17-0003	4	HEX. BOLT GR2 ZINC 1/4-20 X 5/8"
11	NC02-25-0007	4	WASHER ZINC 0.281 = 9/32
12	NC01-96-0009	4	NYLON-INSERT LOCKNUT ZINC 1/4-20
13	NCI3-25-0110	10	SNUG-FIT DAMPING LOOP CLAMP
14	NC01-78-0016	10	ALUMINIUM BLIND POP RIVET STEEL MANDREL 0.187 X 0.690
15	NCI3-25-0245	3	BLACK TIE RAP
16	NCI3-25-0388	1	TRAILER 7 WAY ROUND CONNECTOR WITH SPRING (OPTION)
17	NCI3-25-0381	1	TRAILER 7 FLAT WAY ROUND CONNECTOR (OPTION)

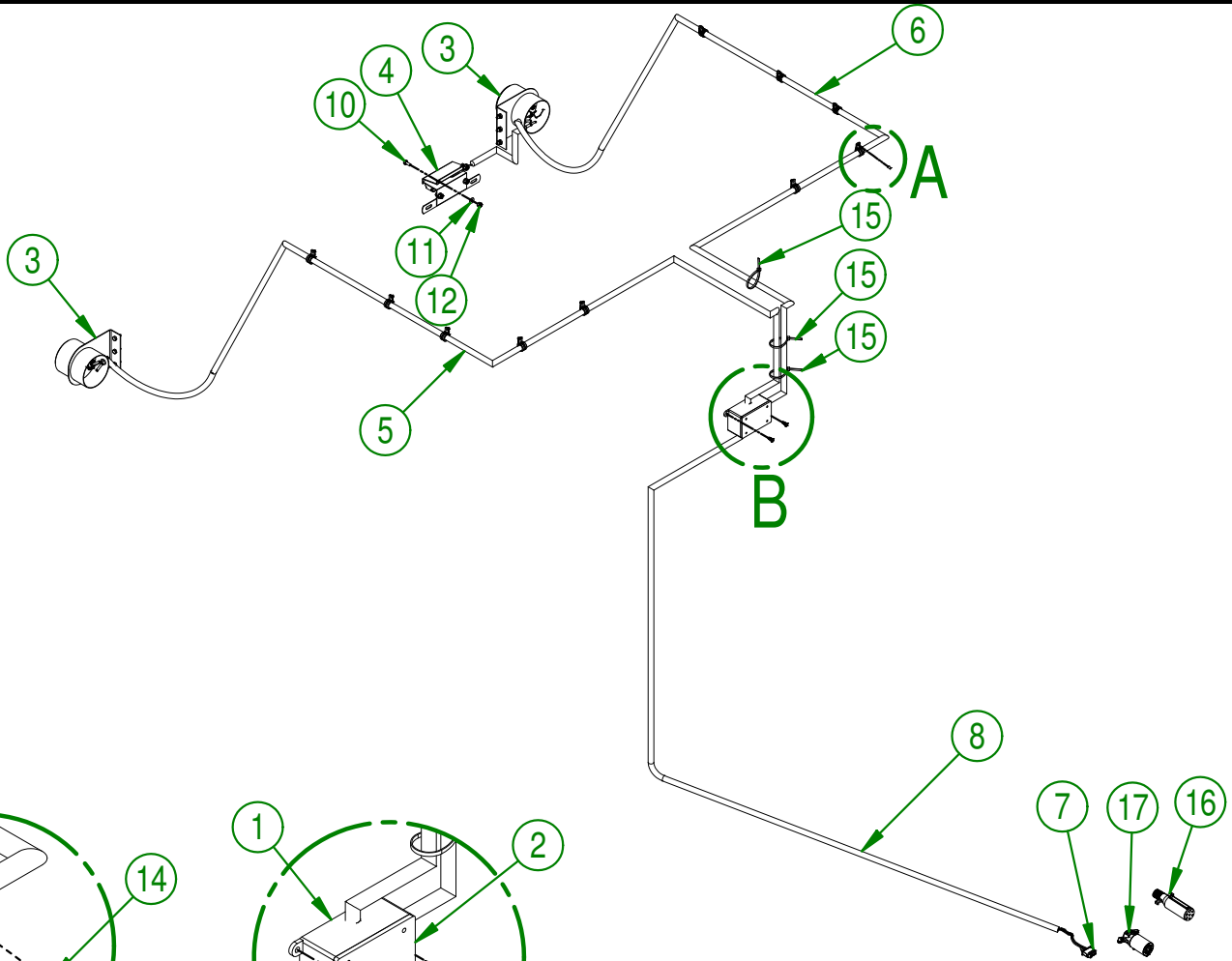

DETAIL A

DETAIL B

AGRIMETAL	
STOP AND TURN LIGHT KIT (OPTION)	
CREATION : 04/10/17	ASSEMBLY : 22-55-0205
REVISION : 06/04/18	AUTHOR : F.HÉLIE Page 59 de 67

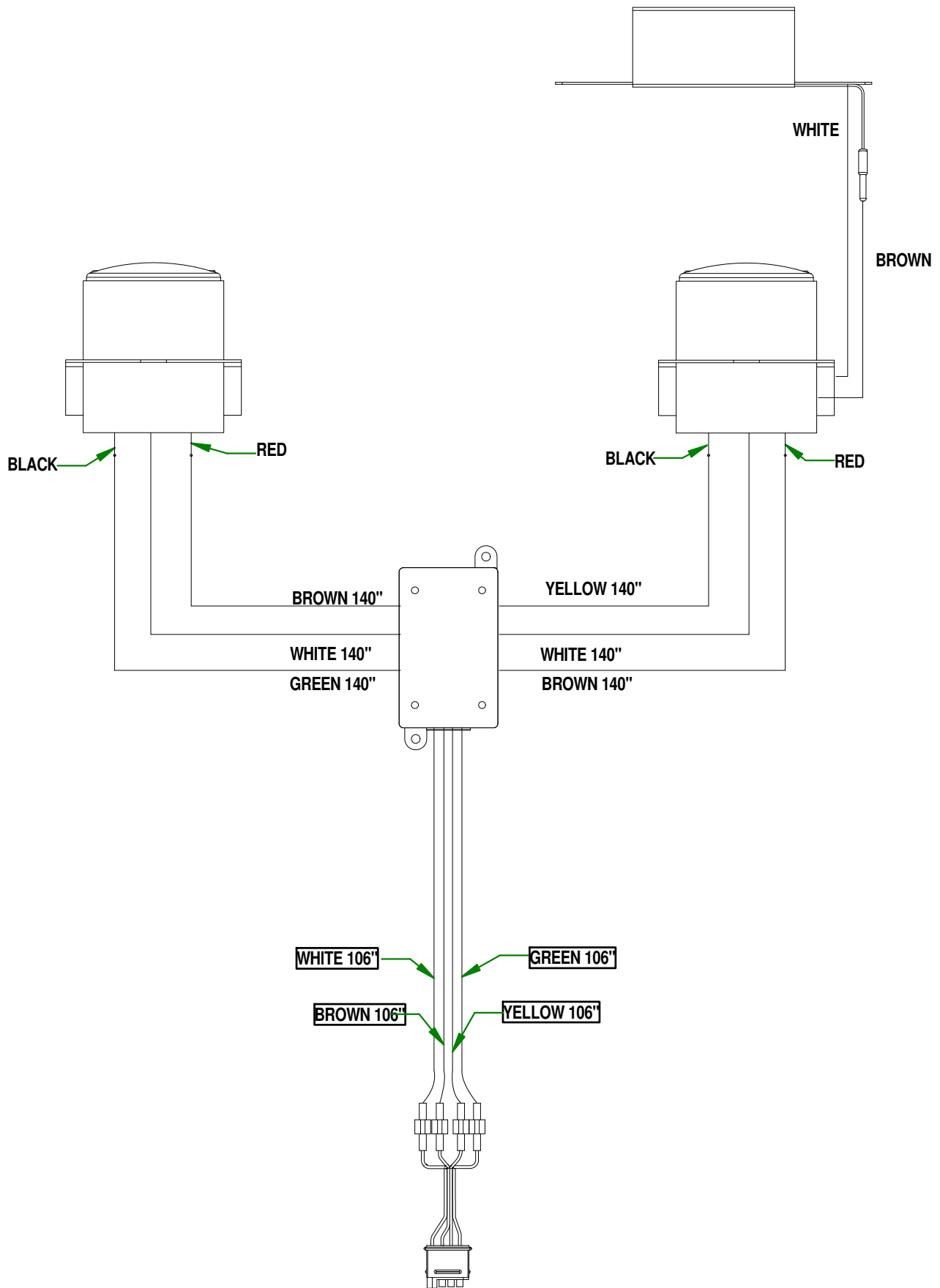

AGRIMETAL	
STOP AND TURN LIGHT KIT (OPTION)	
CREATION : 04/10/17	ASSEMBLY : 22-55-0205
REVISION : 06/04/18	AUTHOR : F.HÉLIE Page 60 de 67

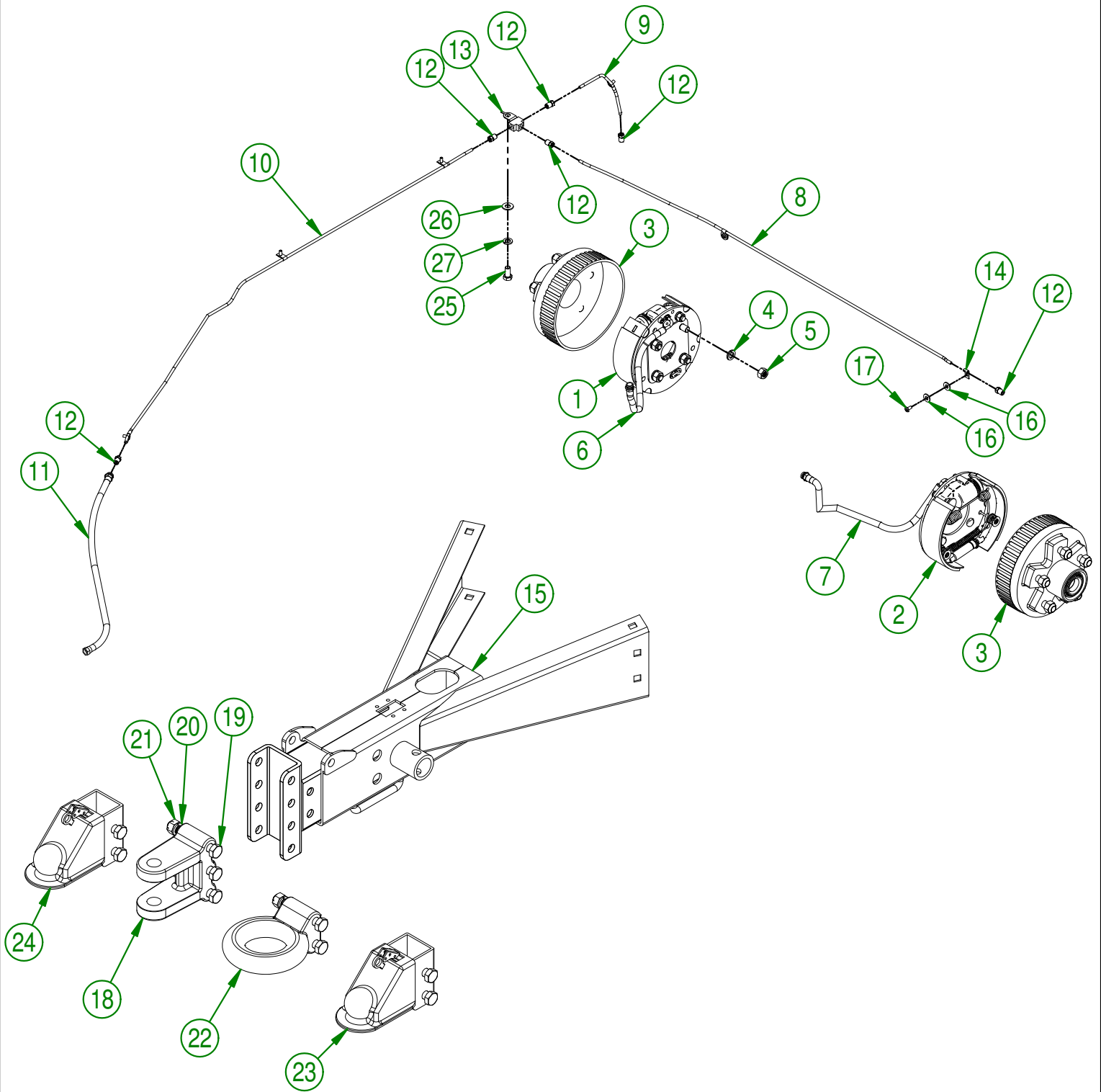

AGRIMETAL	
HYDRAULIC BRAKE KIT (OPTION)	
CREATION : 22/03/18	ASSEMBLY : 22-57-0295
REVISION : 04/05/18	AUTHOR : F.HÉLIE Page 61 de 67

#	PART #	Qty	TITLE
1	NC14-70-0634	1	BRAKE 7" X 1 3/4" UNI 2.5K RH
2	NC14-70-0635	1	BRAKE 7" X 1 3/4" UNI 2.5K LH
3	NC14-70-0638	2	HUB/DRUM KIT 5/4.5 HYD.
4	NC14-70-0637	8	LOCK WASHER ZINC 0.4375 = 7/16
5	NC14-70-0636	8	HEX NUT 7/16" NF
6	NC14-70-0640	1	(BRAKE) FLEXIBLE HOSE 18"
7	NC14-70-0640	1	(BRAKE) FLEXIBLE HOSE 18"
8	22-55-0645	1	RIGID BRAKE LINE 3/16" X 35" LG.
9	22-55-0650	1	RIGID BRAKE LINE 3/16" X 7" LG.
10	22-55-0655	1	RIGID BRAKE LINE 3/16" X 44" LG.
11	NC14-70-0624	1	FLEXIBLE HOSE 18"
12	NC14-70-0623	6	BOLT FOR RIGID HOSE 3/16"
13	NC14-70-0630	1	T UNION 3/16" WITH BRACKET (3XKIT MV)
14	NC13-25-0391	6	LOOP CLAMPS
15	22-55-0640	1	ACTIVATOR 10 & ADJUSTABLE SUPPORT (OPTION)
16	NC02-25-0007	4	WASHER ZINC 0.281 = 9/32
17	NC01-78-0015	6	RIVET 3/16"
18	NC13-80-0241	1	ADJUSTABLE 1" CLEVIS (3 HOLES)
19	NC01-33-0406	9	HEX. BOLT GR8 ZINC 5/8-11 X 4 1/2" LG
20	NC02-32-0016	9	LOCK WASHER ZINC 5/8"
21	NC02-07-0022	9	HEX. NUT ZINC 5/8-11
22	NC14-70-0601	1	ADJUSTABLE 3" LUNETTE RING (2 HOLES)
23	NC14-70-0620	1	ADJUSTABLE 2" BALL COUPLER
24	NC14-70-0602	1	ADJUSTABLE 2-5/16" BALL COUPLER (2 HOLES)
25	NC01-17-0112	1	HEX. BOLT GR2 ZINC 3/8-16 X 3/4"
26	01-01-2485	1	FLAT WASHER 14 GA X 13/16"OD X 25/64" ID
27	NC02-32-0012	1	LOCK WASHER ZINC 3/8"

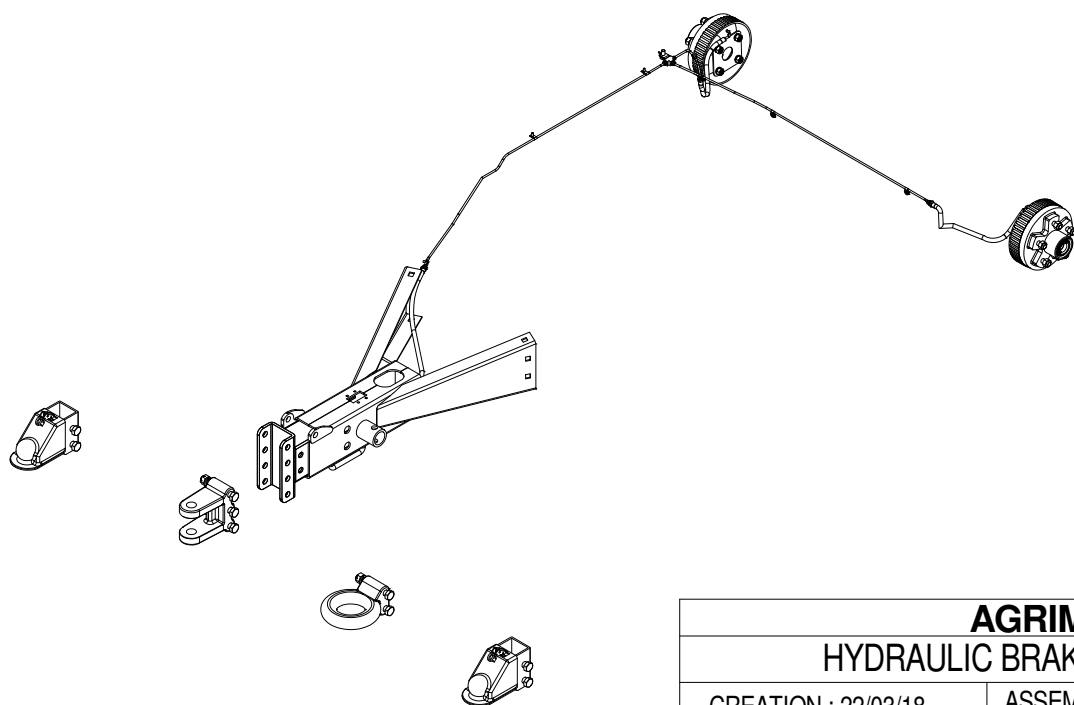

AGRIMETAL	
HYDRAULIC BRAKE KIT (OPTION)	
CREATION : 22/03/18	ASSEMBLY : 22-57-0295
REVISION : 04/05/18	AUTHOR : F.HÉLIE Page 62 de 67

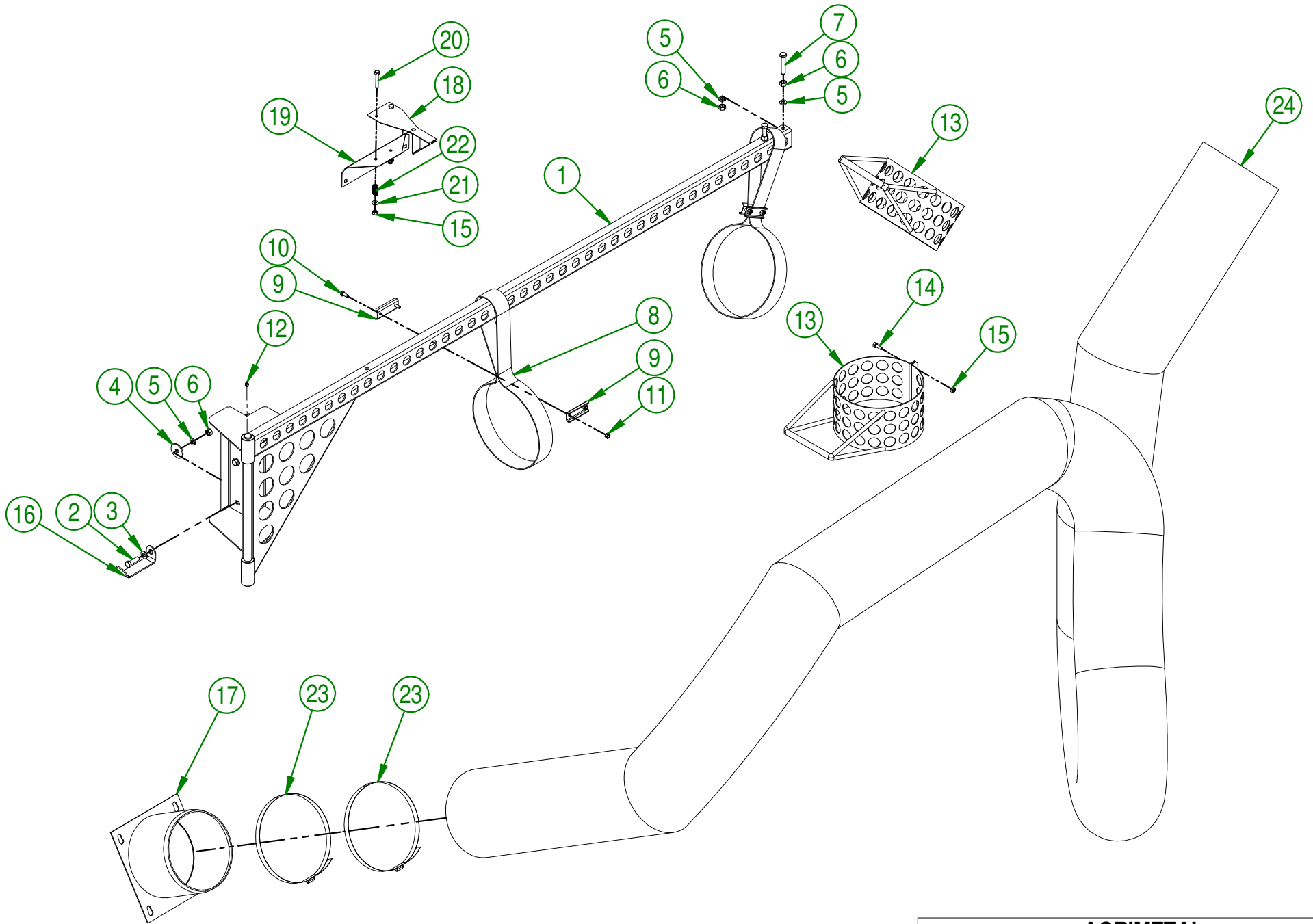

AGRIMETAL	
HOSE KIT (OPTION)	
CREATION : 2017-10-06	ASSEMBLY : 22-57-0250
REVISION : 2018-05-04	AUTHOR : Dessin2 Page 63 de 67

#	PART #	Qty	TITLE
1	16-50-0120	1	FLEXIBLE HOSE SUPPORT
2	NC01-17-0115	6	HEX. BOLT GR2 ZINC 3/8-16 X 1 1/4"
3	01-01-2485	6	FLAT WASHER
4	01-33-0010	6	WASHER
5	NC02-32-0012	10	LOCK WASHER ZINC 3/8"
6	NC02-07-0018	10	HEX. NUT ZINC 3/8-16
7	NC01-17-0118	2	HEX. BOLT GR2 ZINC 3/8-16 X 2"
8	22-41-4000	2	YELLOW STRAP ONLY
9	16-01-2650	4	STRAP SECURING
10	NC01-29-0003	4	HEX. BOLT GR5 ZINC 1/4-28 X 5/8"
11	NC01-97-0004	4	NYLON-INSERT LOCKNUT ZINC 1/4-28
12	NC01-69-0785	2	STRAIGHT GREASE FITTING 1/4-28
13	16-50-0125	2	OPT. VACUUM PIPE HANDLE
14	NC01-17-0004	6	HEX. BOLT GR2 ZINC 1/4-20 X 3/4"
15	NC01-96-0009	8	NYLON-INSERT LOCKNUT ZINC 1/4-20
16	22-01-1540	1	FLEXIBLE HOSE HANDLE HOOK
17	22-50-0160	1	HOSE ADAPTOR 8" DIA.
18	22-50-0070	1	HOSE SUPPORT LOCK
19	22-01-3120	1	HOSE SUPPORT LOCK BRACKET
20	NC01-17-0008	2	HEX. BOLT GR2 ZINC 1/4-20 X 1 1/2"
21	NC02-25-0007	2	WASHER ZINC 0.281 = 9/32
22	NC13-85-0027	2	COMPRESSION SPRING .500" DIA. X 1 3/4" LG.
23	NC01-65-0077	2	HOSE CLAMPS (HS128)
24	NC13-40-0008	1	FLEXIBLE VACUUM TUBE 8" DIA. X 192" LG.

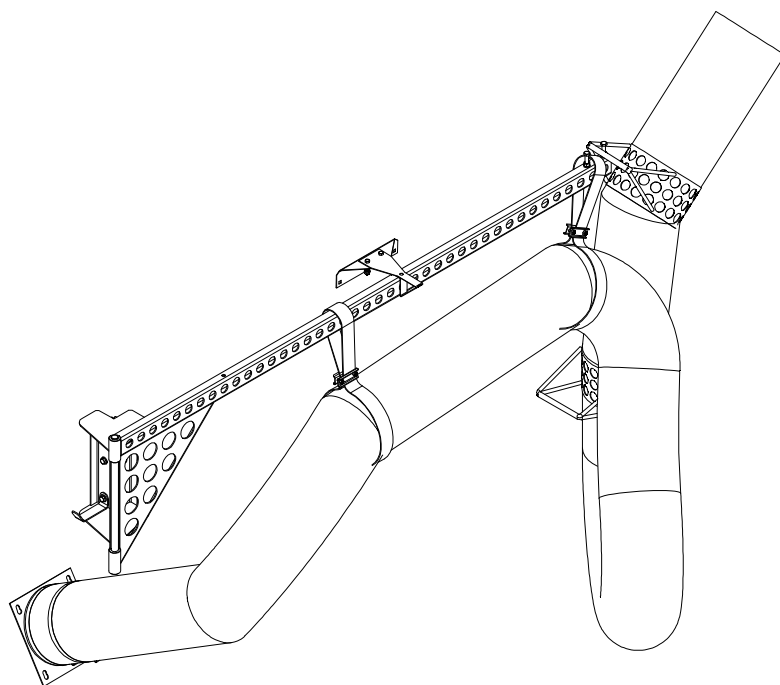

AGRIMETAL
HOSE KIT (OPTION)

CREATION : 06/10/17
REVISION : 04/05/18

ASSEMBLY : **22-57-0250**

AUTHOR : F.HÉLIE Page 64 de 67

#	PART #	Qty	TITLE
1	NC13-30-0237	1	PLASTIC TUBE FOR OPERATOR'S MANUAL
2	NC01-04-0002	3	CARR. BOLT GR2 ZINC 1/4-20 X 5/8"
3	NC02-14-0017	3	FLANGED NUT GR. B 1/4-20
4	NC02-25-0007	3	WASHER ZINC 0.281 = 9/32
5	22-98-0640	1	OPERATION MANUAL (PTO)

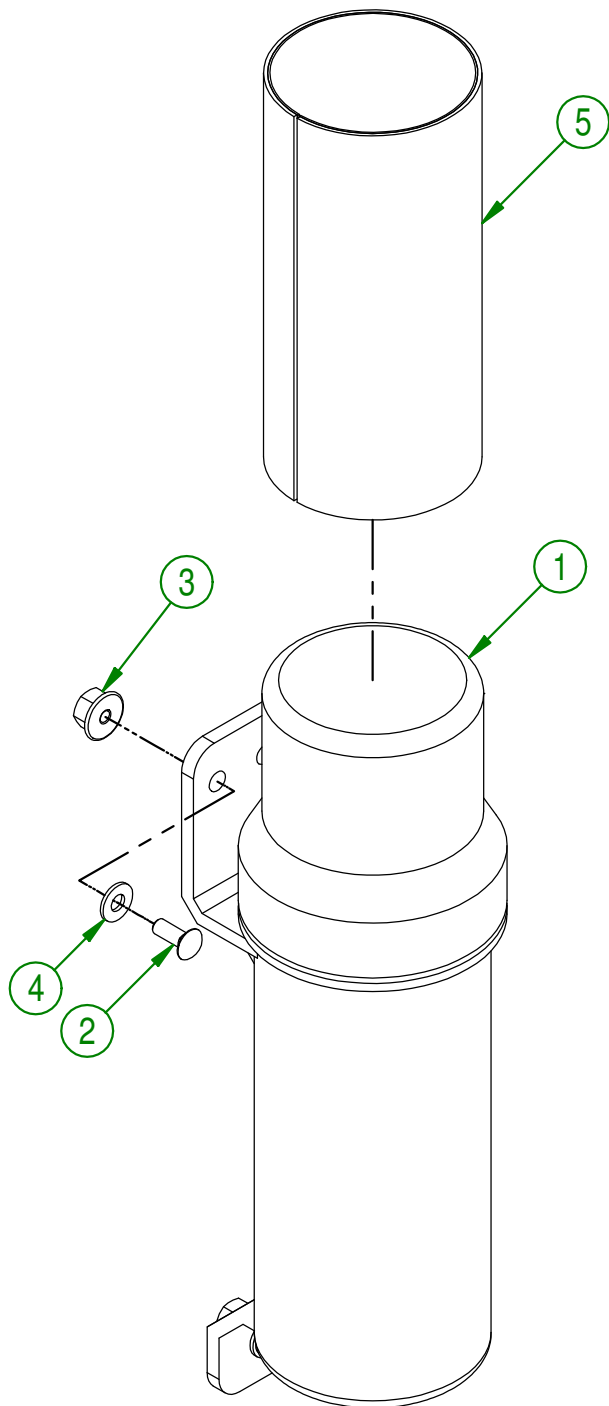

AGRIMETAL		
ASSEMBLY OPERATOR MANUEL TUBE		
CREATION : 2018-04-24	ASSEMBLY :	22-57-0096
REVISION : 2018-04-24	AUTHOR :	Page 65 de 67

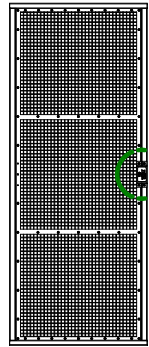

FILTER KIT (OPTION)

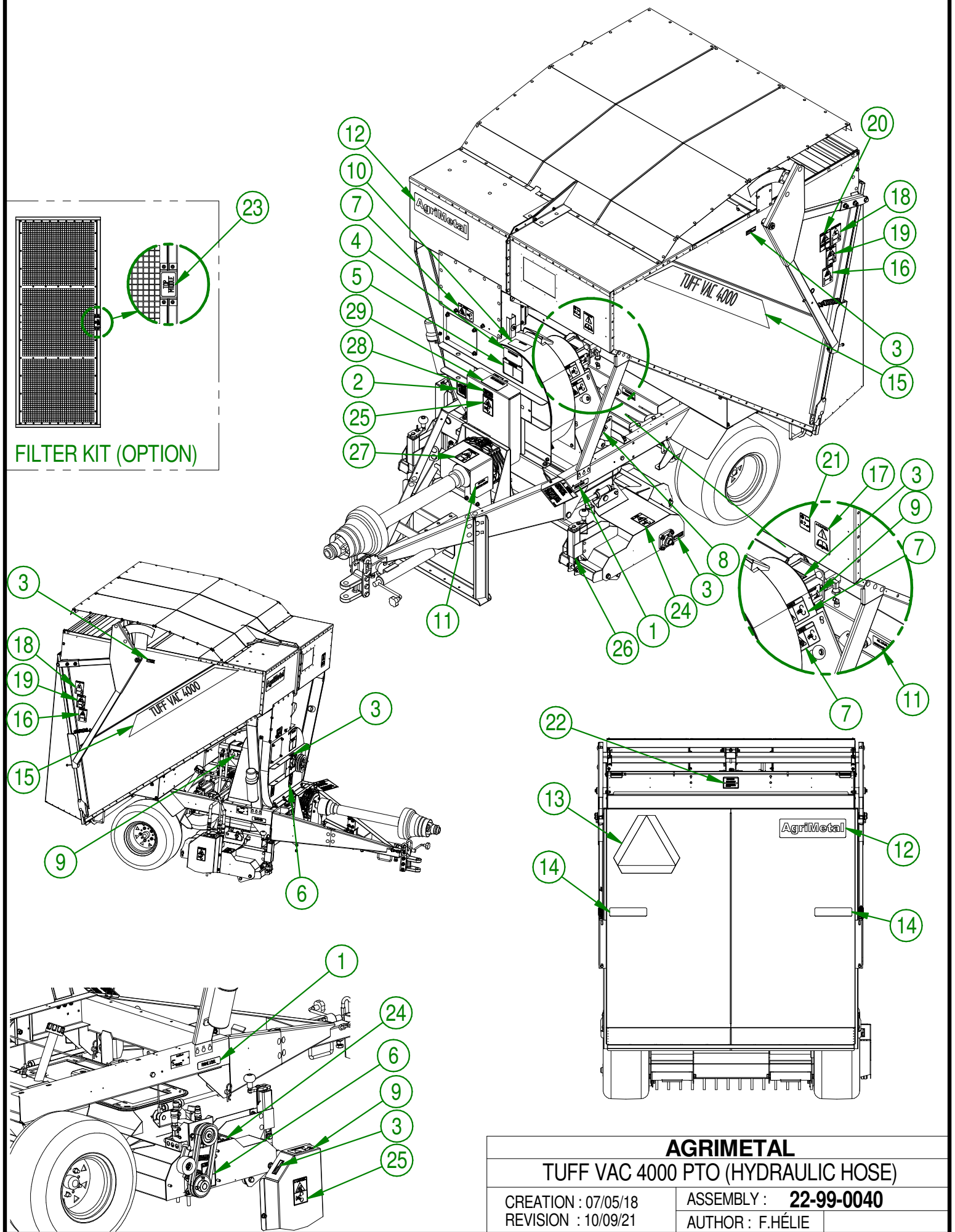

AGRIMETAL	
TUFF VAC 4000 PTO (HYDRAULIC HOSE)	
CREATION : 07/05/18	ASSEMBLY : 22-99-0040
REVISION : 10/09/21	AUTHOR : F.HÉLIE

#	PART #	Qty	TITLE
1	NC13-33-0052	2	STICKER FRAME LEVEL
2	NC13-33-0154	1	STICKER IMPORTANT
3	NC13-33-0024	10	STICKER GREASE HERE
4	NC13-33-0072	1	STICKER IMPORTANT ADJUST TRACTOR AND/OR PTO SHAFT LENGTH
5	NC13-33-0069	1	STICKER IMPORTANT
6	NC13-33-0282	4	STICKER DANGER
7	NC13-33-0249	3	STICKER DANGER
8	NC13-33-0119	1	STICKER HEAD HOSE
9	NC13-33-0288	5	STICKER WARNING HIGH-PRESSURE LIQUID
10	NC13-33-0121	1	STICKER IMPORTANT
11	NC13-33-0003	2	STICKER OIL LEVEL
12	NC13-33-0001	2	STICKER AGRIMETAL
13	NC13-33-0102	1	STICKER TRIANGLE FOR SLOW MACHINARY
14	NC13-33-0149	2	STICKER RED REFLECTOR
15	NC13-33-0094	2	STICKER (TUFF VAC 4000)
16	NC13-33-0192	2	STICKER (PROJECTION RISK)
17	NC13-33-0183	1	STICKER CAUTION OPERATION MANUAL
18	NC13-33-0268	2	STICKER WARNING
19	NC13-33-0260	2	STICKER WARNING
20	NC13-33-0284	1	STICKER WARNING
21	NC13-33-0338	1	STICKER 82 DB
22	NC13-33-0100	1	STICKER IMPORTANT CLOSE AND LATCH SCREEN
23	NC13-33-0107	2	STICKER (TOP MIDDLE)
24	NC13-33-0190	6	STICKER WARNING ROTATING BLADE HAZARD
25	NC13-33-0287	4	STICKER WARNING
26	NC13-33-0155	6	STICKER RULES 3"
27	NC13-33-0187	1	STICKER DANGER (PTO AND PERSON)
28	NC13-33-0005	1	STICKER MAXIMUM 540 RPM
29	NC13-33-0179	1	STICKER IMPORTANT GREASE DRIVE LINE

AGRIMETAL

TUFF VAC 4000 PTO (HOSE HYDRAULIQUE)

CREATION : 07/05/18
REVISION : 10/09/21

ASSEMBLY : **22-99-0040**
AUTHOR : F.HÉLIE