

AgriMetal

PARTS LIST

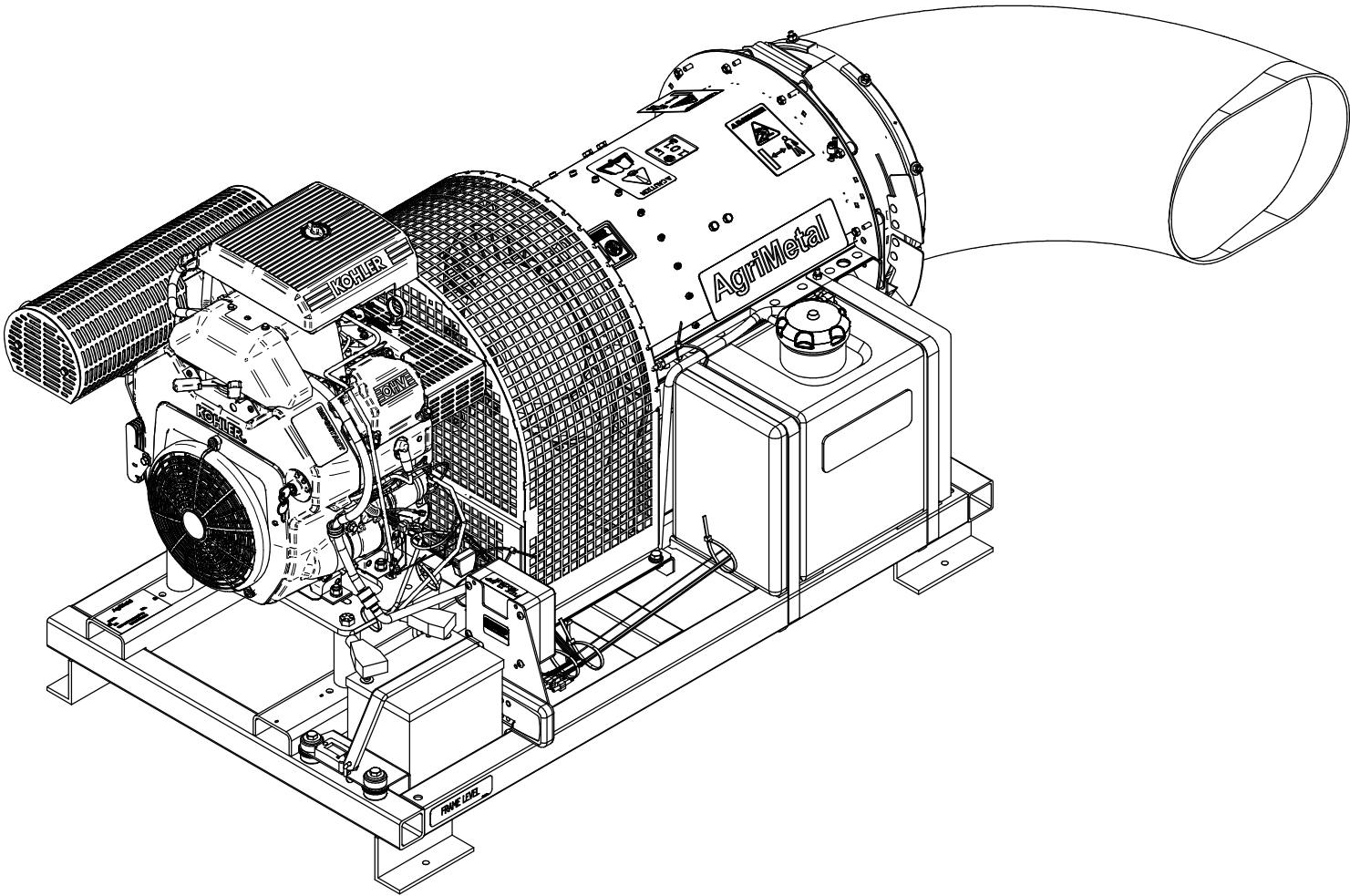

TURBINE BLOWER 270 IC-2 (WITHOUT WHEELS)

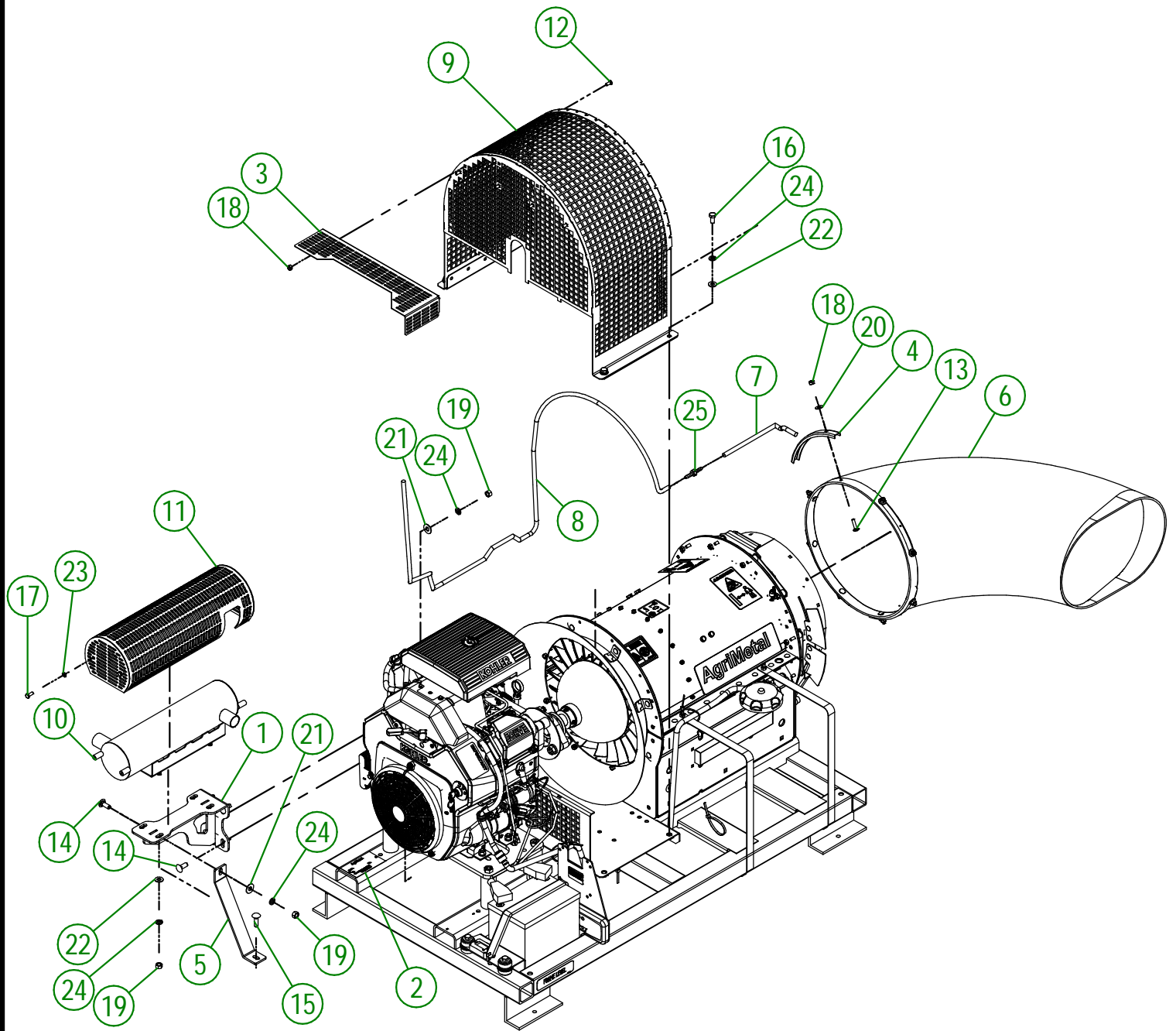

AGRIMETAL		
TURBINE BLOWER 270 IC-2		
CREATION : 09/07/25	ASSEMBLY :	33-99-3003
REVISION : 17/09/25	AUTHOR :	dessin3

33-99-3003

#	PART #	QTY	TITLE
1	22-50-0300	1	MUFFLER SUPPORT (KOHLER 27 HP)
2	25-55-0710	1	SERIAL NUMBER PLATE
3	33-01-0025	1	EXHAUST TUBE GUARD
4	33-01-2480	4	DUCT CLAMP
5	33-04-0350	1	MUFFLER SUPPORT
6	33-42-0005	1	90° PLASTIC ELBOW
7	33-46-0533	1	GAS HOSE 1/2" DIA.X 1/4" D.I. X 10"
8	33-46-0534	1	VENT HOSE 1/2" DIA.X 1/4" D.I. X 71 "
9	33-50-0035	1	TURBINE GUARD (TB-270-240)
10	33-50-1050	1	27 HP KOHLER MUFFLER
11	33-50-1055	1	MUFFLER GUARD (27 HP KOHLER)
12	NC01-04-0001	5	CARR. BOLT GR2 ZINC 1/4-20 X 1/2"
13	NC01-04-0005	8	CARR. BOLT GR2 ZINC 1/4-20 X 1"
14	NC01-04-0109	5	CARR. BOLT GR2 ZINC 3/8-16 X 1"
15	NC01-07-0110	1	CARR. BOLT GR5 ZINC 3/8-16 X 1 1/4"
16	NC01-17-0112	4	HEX. BOLT GR2 ZINC 3/8-16 X 3/4"
17	NC01-29-0003	4	HEX. BOLT GR5 ZINC 1/4-28 X 5/8"
18	NC01-96-0009	13	NYLON-INSERT LOCKNUT ZINC 1/4-20
19	NC02-07-0018	10	HEX. NUT ZINC 3/8-16
20	NC02-22-0008	8	WASHER ZINC 5/16"
21	NC02-22-0010	5	WASHER 13/32" ID
22	NC02-25-0009	9	FLAT WASHER 14 GA X 13/16"OD X 25/64" ID
23	NC02-32-0010	4	LOCK WASHER ZINC 1/4"
24	NC02-32-0012	14	LOCK WASHER ZINC 3/8"
25	NC13-65-0065	1	BARBED HOSE REDUCER 1/4" X 3/16"

#	PART #	QTY	TITLE
1	33-22-2240	1	WIRE PROTECTOR
2	NC02-42-0096	4	PHILLIPS SCREW ZINC #14 X 5/8"
3	NC13-25-0019	10	BLACK TIE RAP
4	NC13-25-0375	1	67" NEW BOX WIRE
5	NC13-25-0370	1	ELECTRIC BOX
6	33-55-0620	1	16 GA WIRE ASSY (PROXIMITY SENSOR)
7	NC13-25-0233	2	COLLET AVEC PROTECTEUR DE VINYL POUR FIL OU TUBE 3/8"
8	NC13-25-0408	1	CAPTEUR DE PROXIMITÉ (GAUCHE)
9	NC13-25-0408	1	CAPTEUR DE PROXIMITÉ (DROIT)

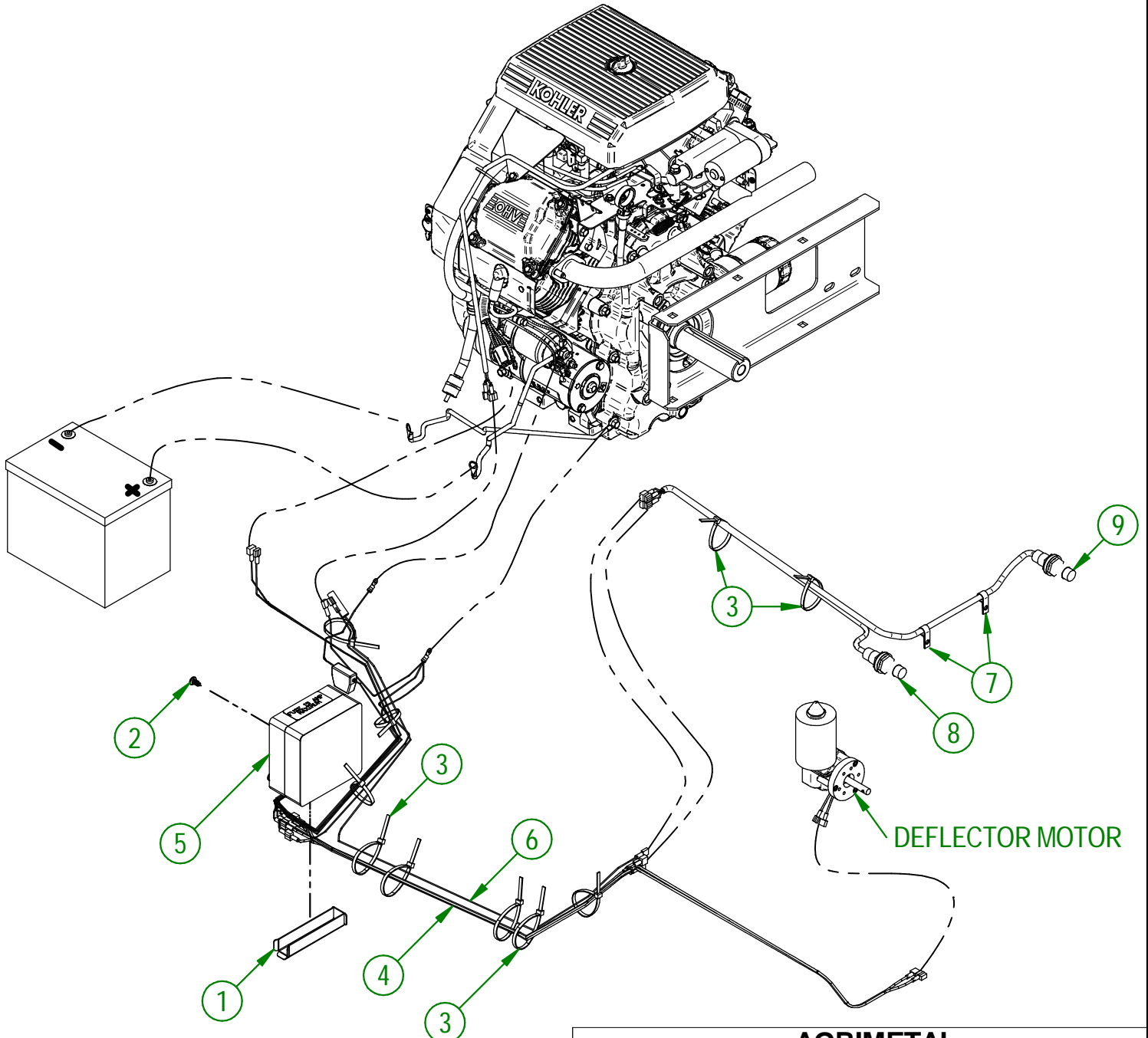

AGRIMETAL	
ASSEMBLY ELECTRIC CONTROL	
CREATION : 09/07/25	ASSEMBLY : 33-57-0507
REVISION : 09/07/25	AUTHOR : D. CHASSÉ

TURBINE BLOWER 270 IC-2

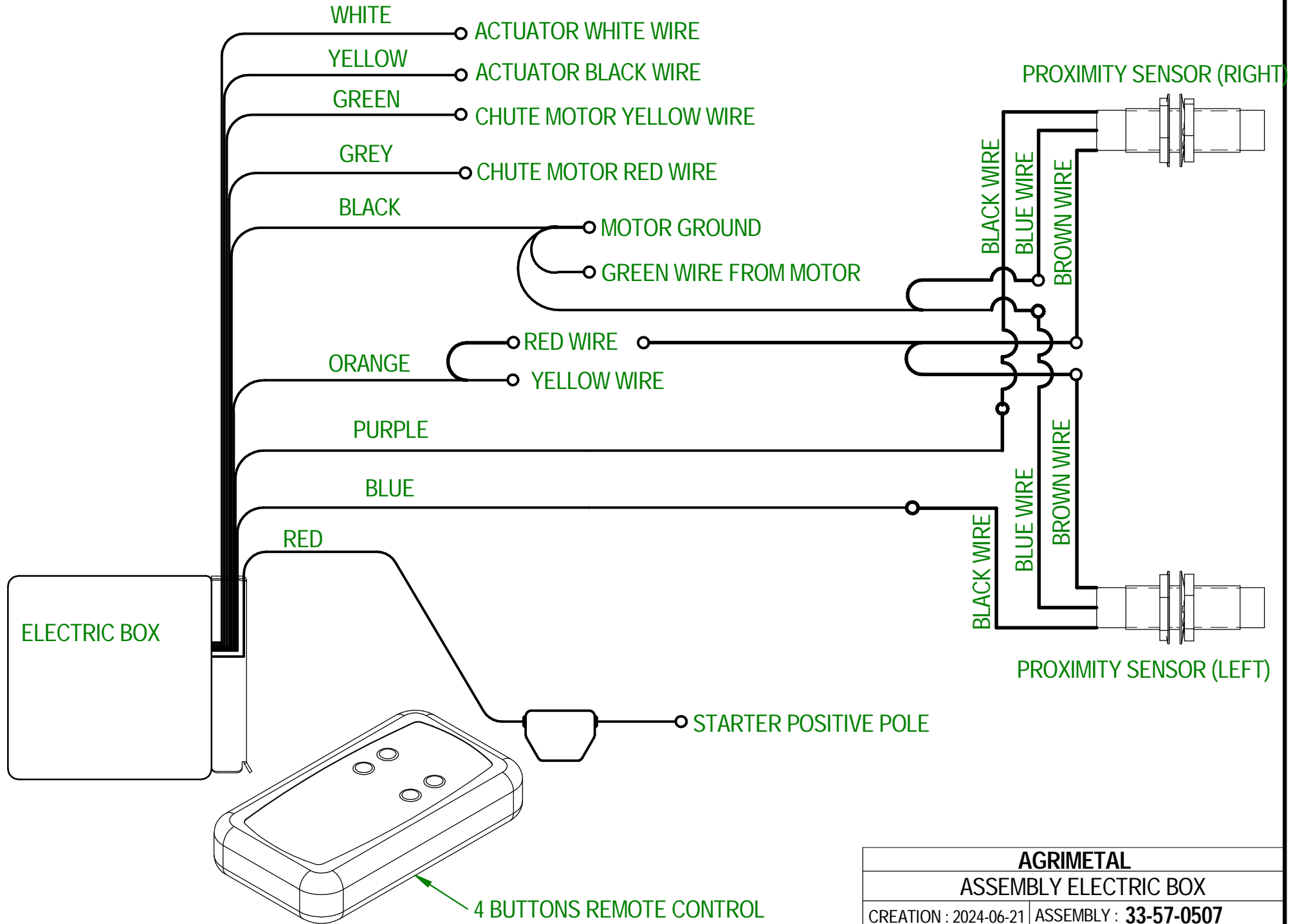

AGRIMETAL	
ASSEMBLY ELECTRIC BOX	
CREATION : 2024-06-21	ASSEMBLY : 33-57-0507
REVISION : 2025-11-19	AUTHOR : D. CHASSÉ

33-57-0165

#	PART #	Qty	TITLE
1	33-55-0200	1	GAS TANK
2	33-01-3045	2	GAS TANK STRAP
3	33-46-0545	1	GAS HOSE 1/2" DIA.X 1/4" D.I. X 50"
4	NC01-04-0002	4	CARR. BOLT GR2 ZINC 1/4-20 X 5/8"
5	NC01-96-0009	4	NYLON-INSERT LOCKNUT ZINC 1/4-20
6	NC01-65-0201	2	SPRING -GRIP HOSE CLAMPS 1/2" O.D
7	NC13-25-0019	3	BLACK TIE RAP
8	33-55-0205	1	GAS CAP

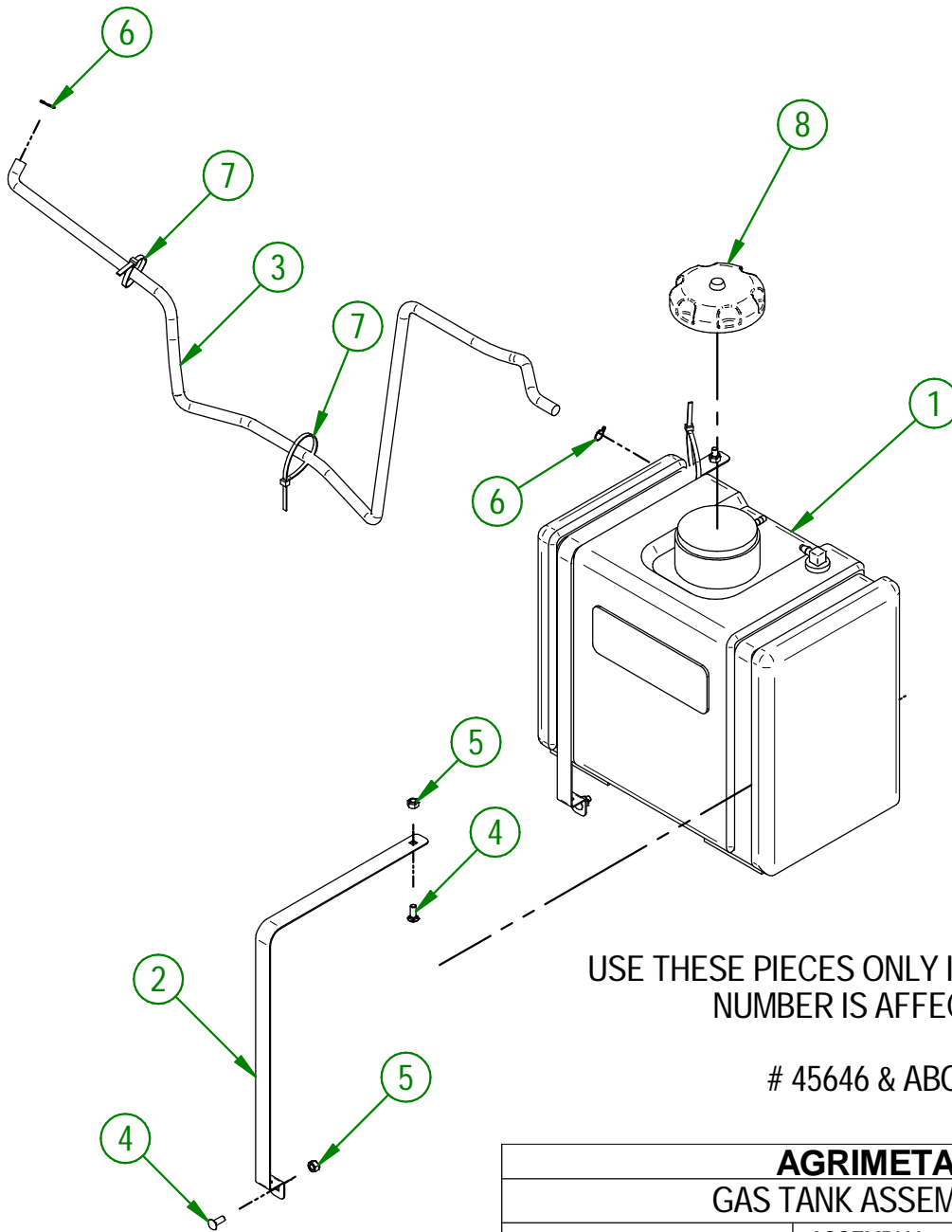

USE THESE PIECES ONLY IF YOUR SERIAL NUMBER IS AFFECTED:

45646 & ABOVE

AGRIMETAL	
GAS TANK ASSEMBLY	
CREATION : 15/05/24	ASSEMBLY : 33-57-0165
REVISION : 21/08/25	AUTHOR : D. CHASSÉ

33-57-2525

#	PART #	Qty	TITLE
1	33-57-2505	1	ASSEMBLY FRAME STICKER INCLUDED
2	NC02-22-0012	4	WASHER ZINC 1/2 BOLT = 9/16"Ø X 1 3/8" OD
3	NC01-94-0013	4	NYLON NUT ZINC 1/2-20"
4	NC01-37-0263	4	HEX. BOLT GR8 NF ZINC 1/2-20 X 5" LG
5	33-57-0215	1	ENGINE BASE GROUP

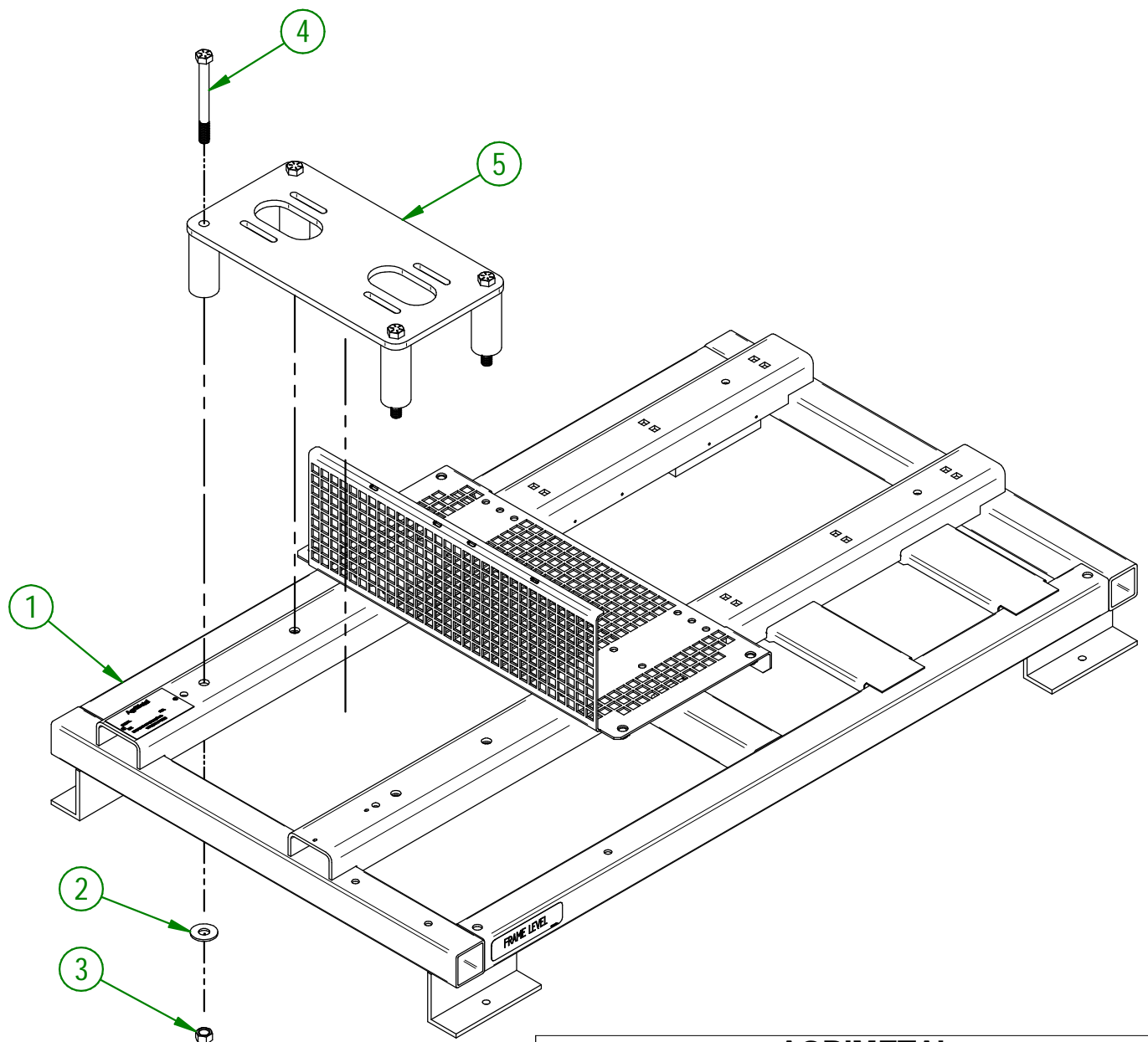

AGRIMETAL
ASSEMBLY FRAME

CREATION : 11/05/23
REVISION : 29/11/23

ASSEMBLY : **33-57-2525**
AUTHOR : D. CHASSÉ

33-57-2525

#	PART #	Qty	TITLE
1	33-57-2505	1	ASSEMBLY FRAME STICKER INCLUDED
2	NC02-22-0012	4	WASHER ZINC 1/2 BOLT = 9/16"Ø X 1 3/8" OD
3	NC01-94-0013	4	NYLON NUT ZINC 1/2-20"
4	NC01-37-0263	4	HEX. BOLT GR8 NF ZINC 1/2-20 X 5" LG
5	33-57-0215	1	ENGINE BASE GROUP

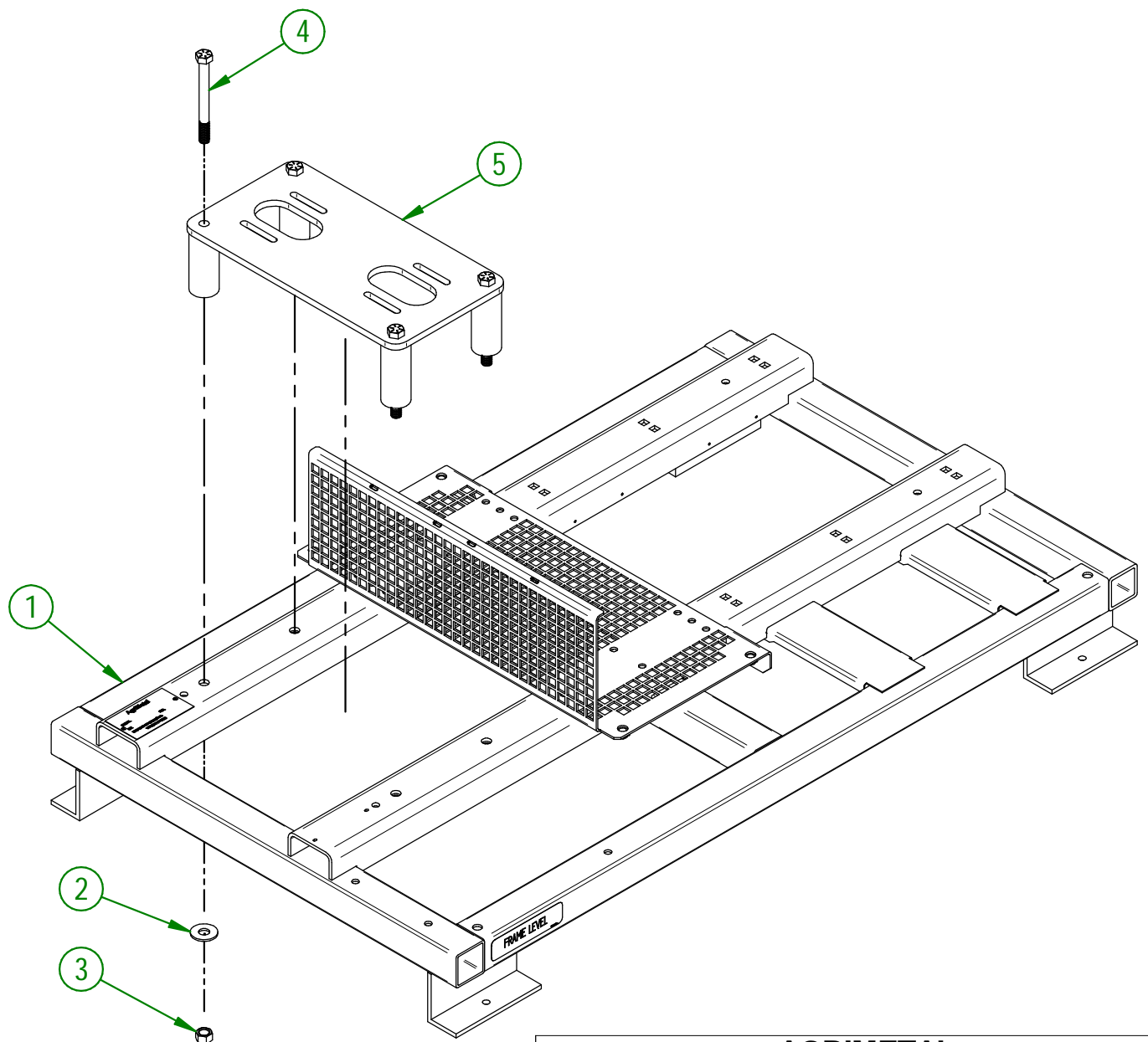

AGRIMETAL
ASSEMBLY FRAME

CREATION : 11/05/23
REVISION : 29/11/23

ASSEMBLY : **33-57-2525**
AUTHOR : D. CHASSÉ

33-57-2541

#	PART #	Qty	TITLE
1	NC01-02-0112	4	CARR. BOLT GR2 FLZ 3/8-16 X 1 3/4"
2	01-01-2485	4	FLAT WASHER 14 GA X 13/16"OD X 25/64" ID
3	NC02-32-0012	8	LOCK WASHER ZINC 3/8"
4	NC02-07-0018	8	HEX. NUT ZINC 3/8-16
5	33-22-2215	4	ENGINE SHIM ALU. 0.016" X 8.125" X 2"
6	33-22-5600	8	ENGINE STOPPER
7	NC01-04-0109	4	CARR. BOLT GR2 ZINC 3/8-16 X 1"

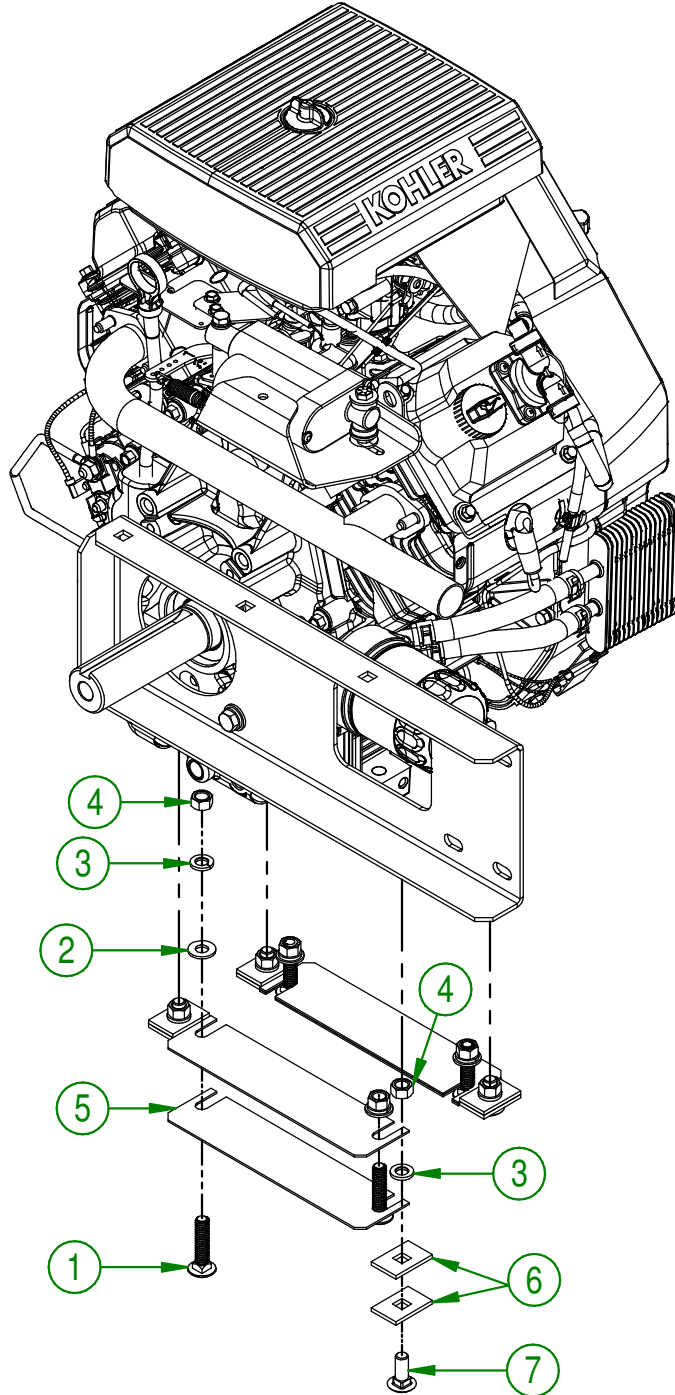

AGRIMETAL	
27 HP ENGINE GROUP.	
CREATION : 01/11/17	ASSEMBLY : 33-57-2541
REVISION : 12/10/18	AUTHOR : J.KABWE

#	PART#	QTY	TITLE
1	33-01-0900	1	MOFFLER SUPPORT
2	33-35-5000	1	EXHAUST MANIFOLD
3	33-01-0040	1	ACTUATOR SUPPORT
4	NC01-37-0008	1	HEX. BOLT GR8 1/4-28 X 1 1/2"
5	NC01-37-0006	1	HEX BOLT GR8 NF ZINC 1/4-28 X 1
6	33-21-0070	1	ACTUATOR SUPPORT BUSHING
7	33-21-0075	1	ACTUATOR SUPPORT BUSHING
8	NC01-97-0004	2	NYLON-INSERT LOCKNUT ZINC 1/4-28
9	33-01-0425	1	ACTUATOR SUPPORT
10	01-01-2485	4	FLAT WASHER 14 GA X 13/16"OD X 25/64" ID
11	NC02-32-0012	4	LOCK WASHER ZINC 3/8"
12	NC01-25-0114	4	HEX. BOLT GR5 ZINC 3/8-16 X 1"
13	33-55-1505	1	ASSEMBLY BATTERY RED CABLE #4
14	33-55-2500	1	ASSEMBLY BATTERY BLACK CABLE #4
15	NC13-25-0110	1	SNUG-FIT DAMPING LOOP CLAMP
16	33-46-0527	1	1/4" GAS HOSE
17	NC01-45-0062	1	METR. BOLT GR 8.8 4MM X0.70P X 40MM
18	33-46-0595	1	1/4" GAS HOSE
19	NC13-80-0339	1	1/4" PRIMING BULB
20	NC01-65-0201	2	SPRING -GRIP HOSE CLAMPS 1/2" O.D

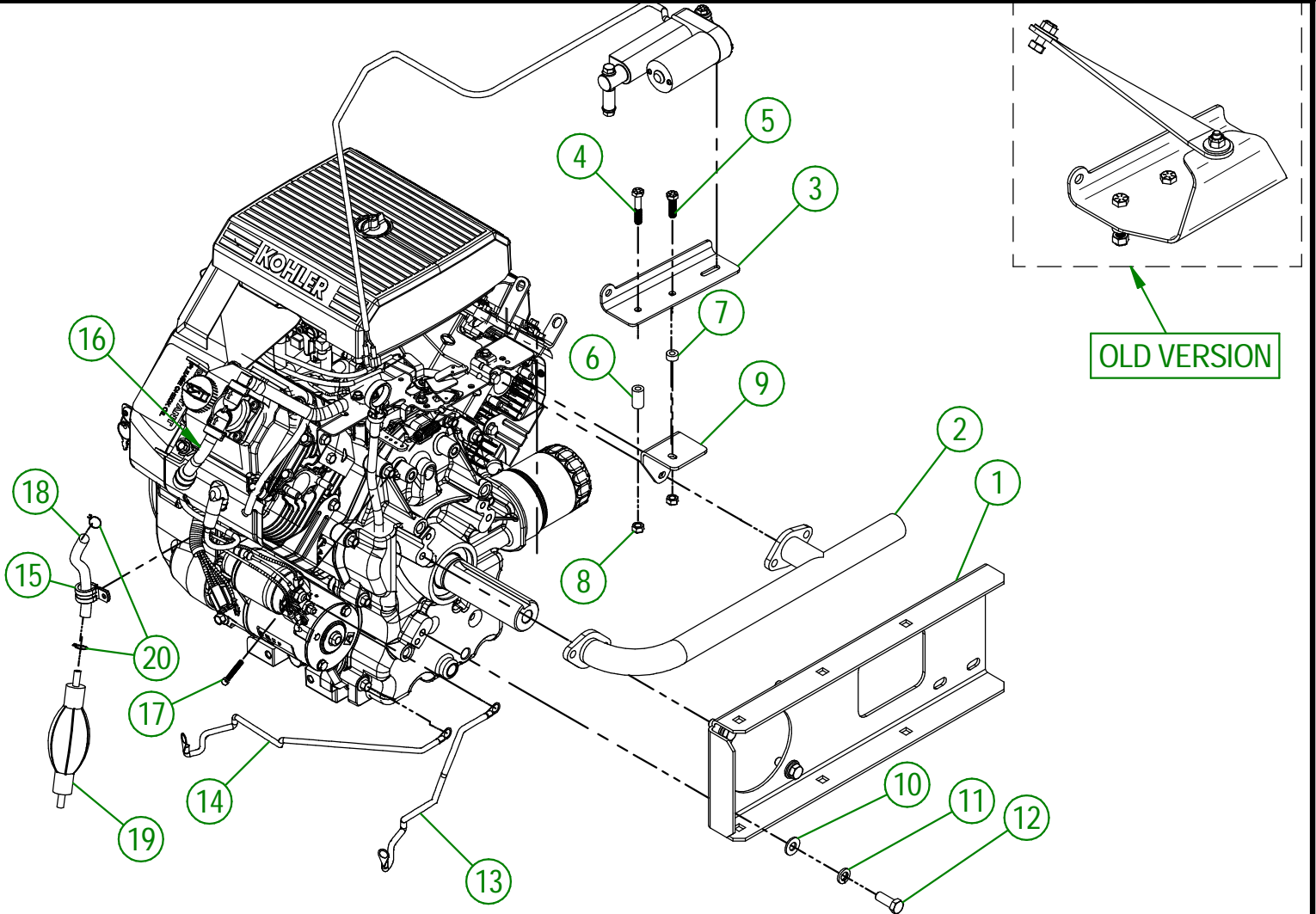

AGRIMETAL
27 HP KOHLER ENGINE STARTER ASSY.

CREATION : 01/11/17	ASSEMBLY : 33-55-2531
REVISION : 29/01/26	AUTHOR : J.KABWE

MACHINE: TURBINE BLOWER 270

#	PART #	Qty	TITLE
1	33-55-0100	1	ACTUATOR 12 VOLTS
2	33-57-0107	1	ACTION ROD
3	NC01-37-0011	1	HEX. BOLT GR8 1/4-28 X 2 1/4
4	33-42-0120	2	PIVOT BUSHING
5	NC02-14-1200	1	TWO WAY LOCK NUT 1/4-28
6	NC02-25-0007	4	WASHER ZINC 0.281 = 9/32
7	36-01-2430	2	FLAT WASHER 14GA X 17/64" I.D. X 13/16" O.D.
8	NC01-97-0004	1	NYLON-INSERT LOCKNUT ZINC 1/4-28

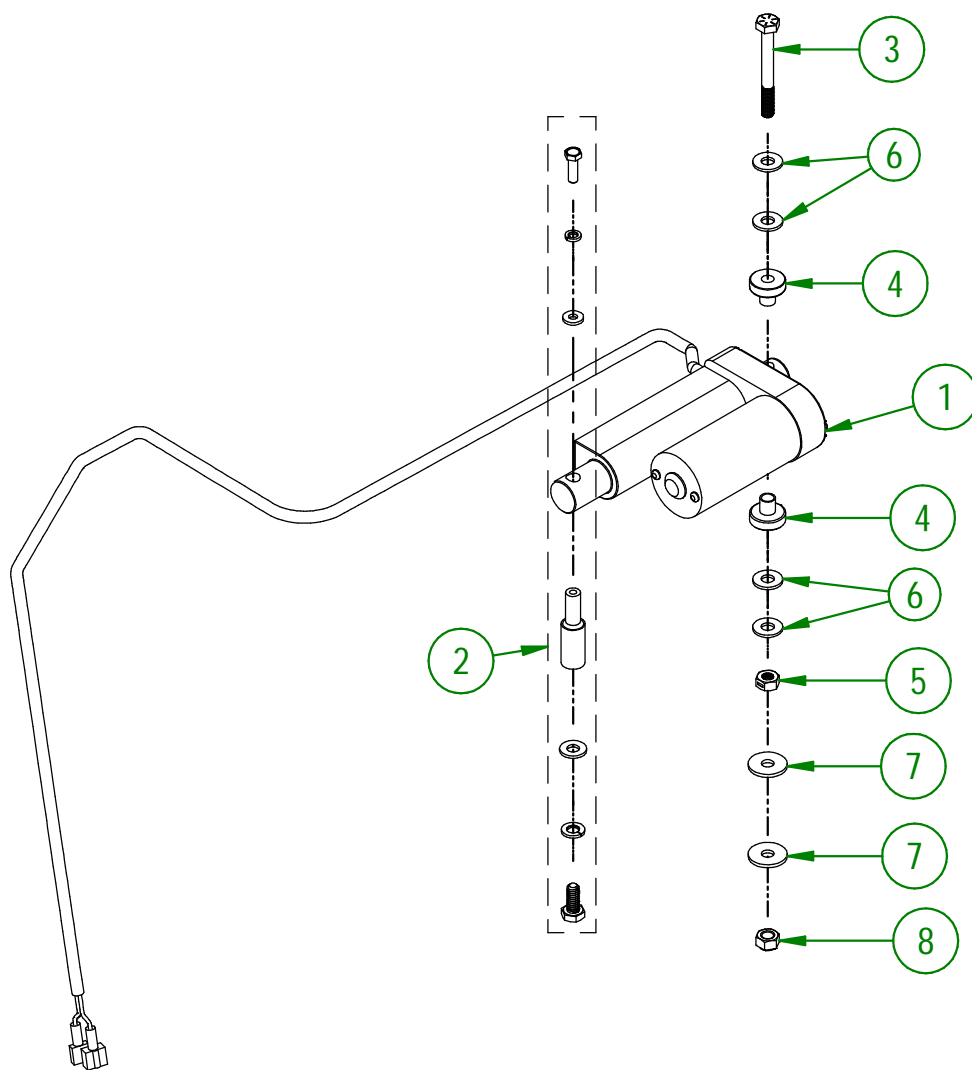

AGRIMETAL	
ASSEMBLY ACTUATOR 12 VOLTS	
CREATION : 17/04/18	ASSEMBLY : 33-55-0107
REVISION : 21/06/24	AUTHOR : J.KABWE

#	PART #	Qty	TITLE
1	33-04-1600	2	FLANGE
2	33-21-0055	4	SLEEVE
3	01-01-0925	4	WASHER
4	33-01-7570	2	WASHER
5	NC14-62-0016	1	QD BUSHING SH I 1/4"
6	NC14-62-0211	1	QD BUSHING SH I 7/16"
7	33-20-0152	2	SPACER
8	NC01-37-0253	4	HEX. BOLT GR8 ZINC 1/2-20 X 2 1/2"
9	NC01-94-0013	4	NYLON NUT ZINC 1/2-20"
10	NC01-65-0308	1	SQUARE KEY 1/4" X 1 3/4"

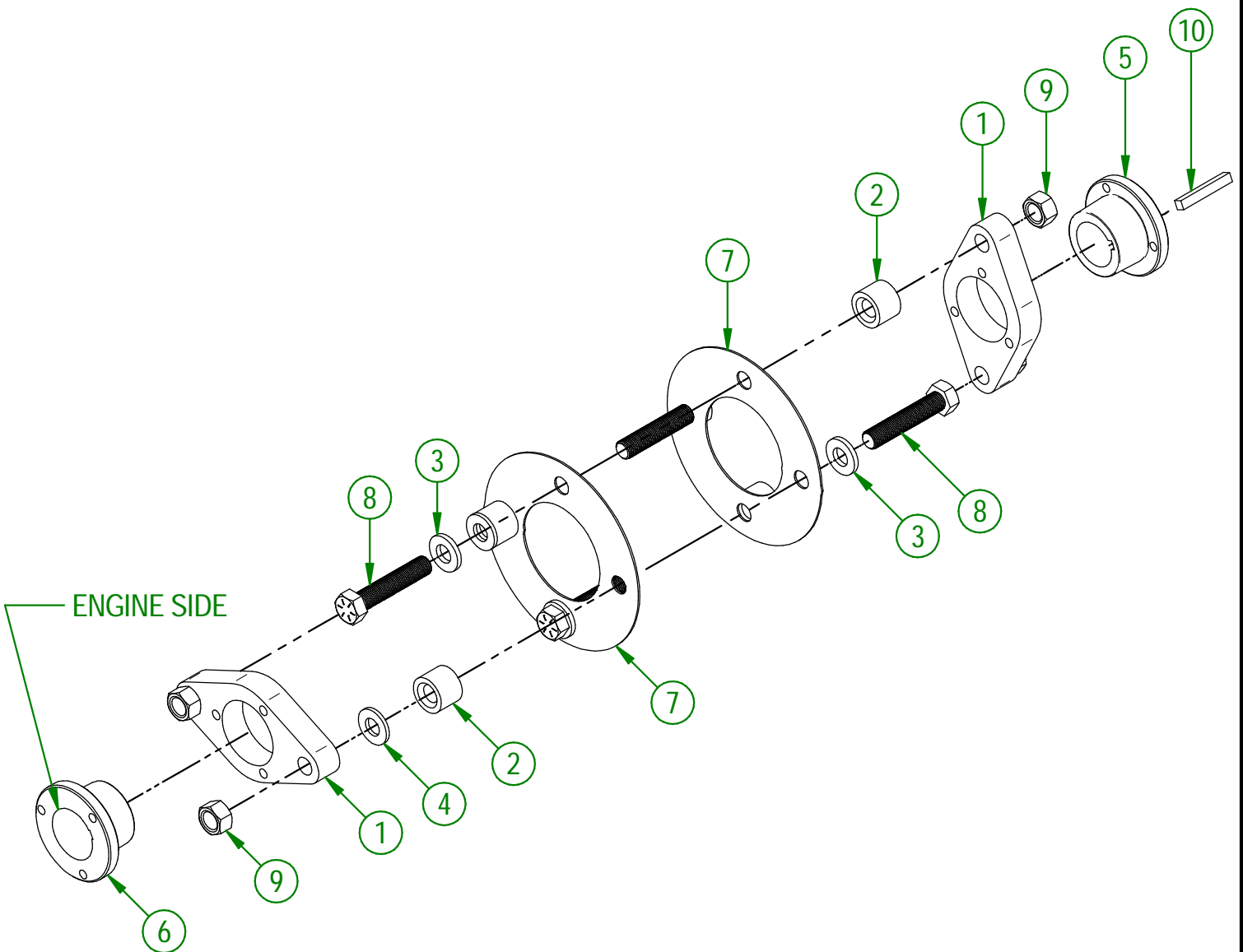

AGRIMETAL	
COUPLING ASSEMBLY	
CREATION : 03/11/17	ASSEMBLY : 33-57-0046
REVISION : 07/07/25	AUTHOR : J.KABWE

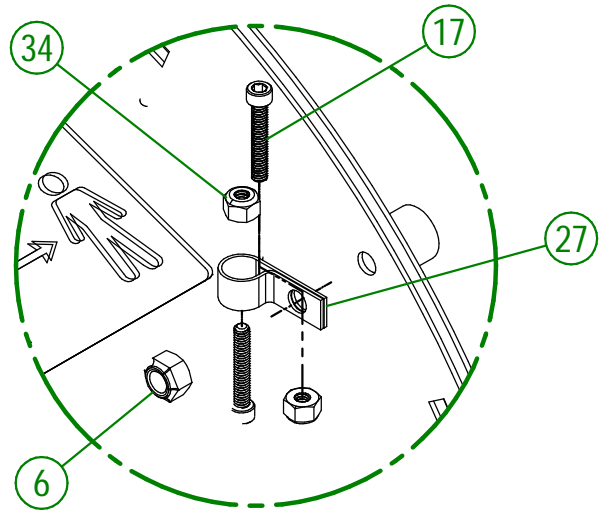
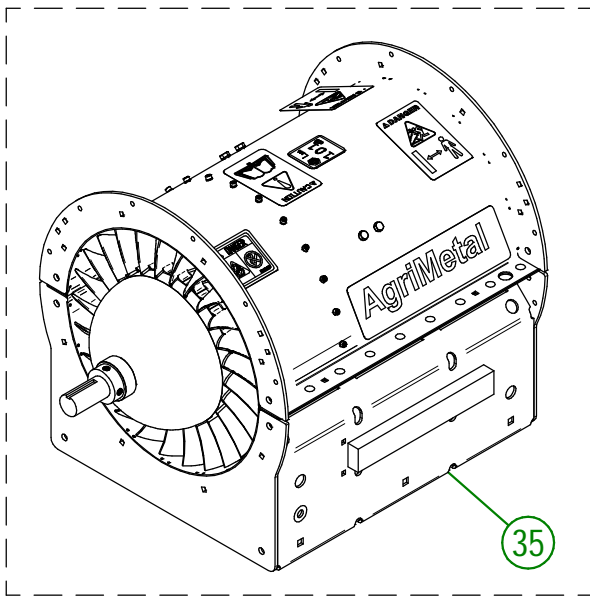

DETAIL A

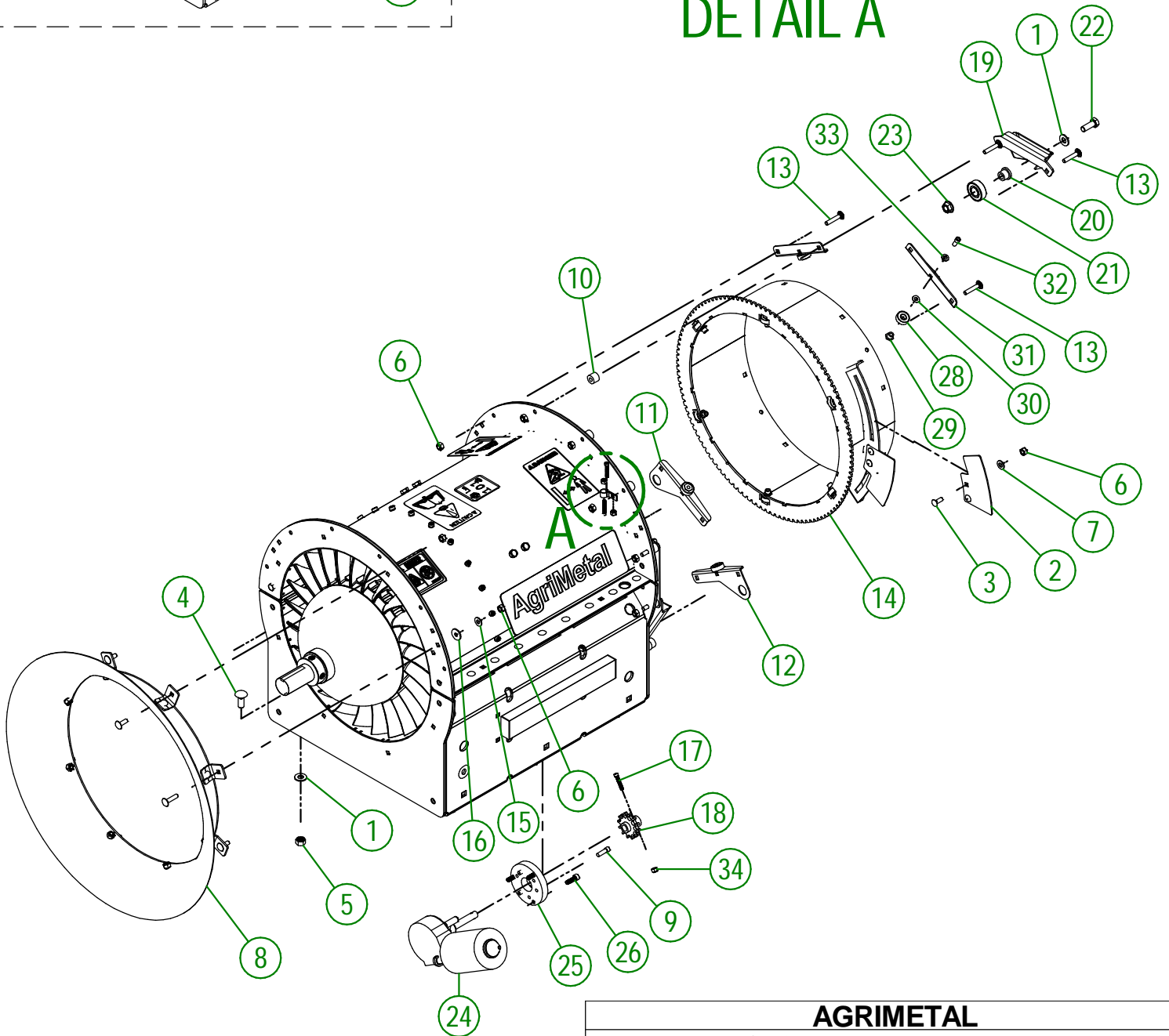

AGRIMETAL	
REGROUP. TURBINE BLOWER	
CREATION : 09/07/25	ASSEMBLY : 33-57-0022
REVISION : 09/07/25	AUTHOR : D. CHASSÉ

33-57-0022

#	PART #	QTY	TITLE
1	NC02-25-0009	9	FLAT WASHER 14 GA X 13/16"OD X 25/64" ID
2	33-01-0370	2	ROTATION TRIGGER PLATE
3	NC01-04-0002	4	CARR. BOLT GR2 ZINC 1/4-20 X 5/8"
4	NC01-04-0109	6	CARR. BOLT GR2 ZINC 3/8-16 X 1"
5	NC01-93-0011	6	LOCK NUT 3/8-16
6	NC01-96-0009	45	NYLON-INSERT LOCKNUT ZINC 1/4-20
7	NC02-22-0008	4	WASHER ZINC 5/16"
8	33-55-0085	1	AIR INTAKE ASSY.
9	NC02-51-0080	3	SOCKET CAP SCREW T.RON 1/4-28 X 3/4"
10	33-21-0080	12	SPACER
11	33-55-0140	1	RIGHT LIMIT SWITCH & BEARING GUIDE ASSY.
12	33-55-0145	1	LEFT LIMIT SWITCH & BEARING GUIDE ASSY.
13	NC01-04-0006	12	CARR. BOLT GR2 ZINC 1/4-20 X 1 1/4"
14	33-55-0066	1	OUTLET SPROCKET
15	NC02-25-0007	2	WASHER ZINC 0.281 = 9/32
16	36-01-2430	3	FLAT WASHER 14GA X 17/64" I.D. X 13/16" O.D.
17	NC02-50-0069	3	SOCKET CAP SCREW T.RON 8-32 X 1"
18	33-50-2002	1	CROWN PINION
19	33-50-0555	3	WELD ASSEMBLY BEARING SUPPORT
20	33-21-0060	3	BEARING HOLDER
21	NC14-75-0068	3	BALL BEARING 99502H
22	NC01-17-0114	3	HEX. BOLT GR2 ZINC 3/8-16 X 1"
23	NC02-14-0019	3	FLANGE NUT HEX. NC 3/8-16 GR. B
24	33-35-0005	1	OUTLET MOTOR
25	33-21-0100	1	ENGINE CONVERSION PLATE
26	NC02-50-1072	3	SOCKET CAP SCREW M6 X 20mm
27	NC13-25-0233	1	VINYLE PROTECTOR COLLAR
28	NC14-75-0153	4	BALL BEARING R6 2RS 3/8" X 7/8" X 0.281"
29	33-25-2410	4	BEARING BUSHING
30	33-03-4605	4	BEARING SHIM 1/4" ALUMINUM
31	33-01-2425	4	BEARING HOLDER BRACKET
32	NC02-51-0578	4	SOCKET CAP SCREW T.RON. NF 1/4-28 X 1/2 STAINLESS
33	NC02-32-0010	7	LOCK WASHER ZINC 1/4"
34	NC01-96-0004	3	8-32 JAM NUT
35	33-57-0082	1	REGROUP.ENSEMBLE DE TURBINE (NEUF)

#	PART #	Qty	TITLE
1	NCI3-12-0017	1	12 VOLTS GEL BATTERY
2	NCI3-80-0267	1	RED PROTECTOR FOR BATTERY POST
3	NCI3-80-0268	1	BLACK PROTECTOR FOR BATTERY POST
4	NCI3-37-0669	1	HOUR METER
5	33-57-2401	1	BATTERY SUPPORT PLATE "INCL. STICKER"
6	NCI3-15-0354	3	RED RUBBER BASE MOUNT
7	26-03-4800	9	WASHER
8	21-01-0950	3	FLAT WASHER 10GA 1.005" DIA X 25/64"
9	NC01-25-0126	3	HEX. BOLT GR5 ZINC 3/8-16 X 4"
10	NC02-25-0009	3	WASHER 0.406" I.D. X 0.815 O.D.
11	NC02-32-0012	3	LOCK WASHER ZINC 3/8"
12	NC02-07-0018	3	HEX. NUT ZINC 3/8-16
13	33-42-0130	2	BLACK ADHESIVE-BACK STRIP
14	NCI3-15-0008	1	RUBBER STRAP
15	33-42-0135	2	BLACK ADHESIVE-BACK STRIP

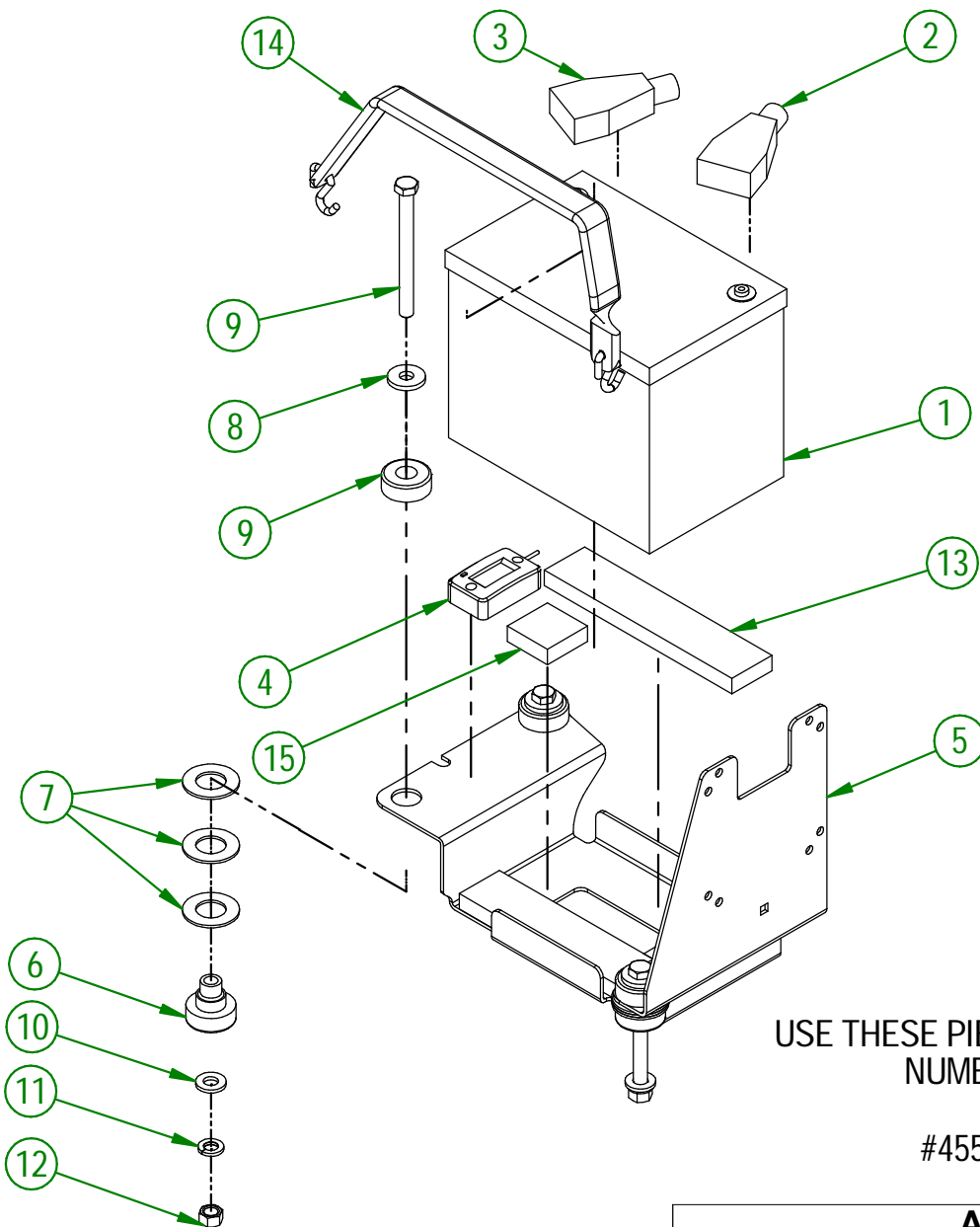

USE THESE PIECES ONLY IF YOUR SERIAL NUMBER IS AFFECTED:

#45503 AND ABOVE

AGRIMETAL	
12 VOLTS BATTERY GROUP.	
CREATION : 21/02/24	ASSEMBLY : 33-57-0170
REVISION : 30/05/25	AUTHOR : D. CHASSÉ

33-57-2566

#	PART #	Qty	TITLE
1	NCI3-30-0237	1	PLASTIC TUBE FOR OPERATOR'S MANUAL
2	NC01-04-0003	3	CARR. BOLT GR2 ZINC 1/4-20 X 3/4"
3	NC02-25-0007	3	WASHER ZINC 0.281 = 9/32
4	NC01-96-0009	3	NYLON-INSERT LOCKNUT ZINC 1/4-20
5	33-98-0621	1	OPERATION MANUAL TB 270

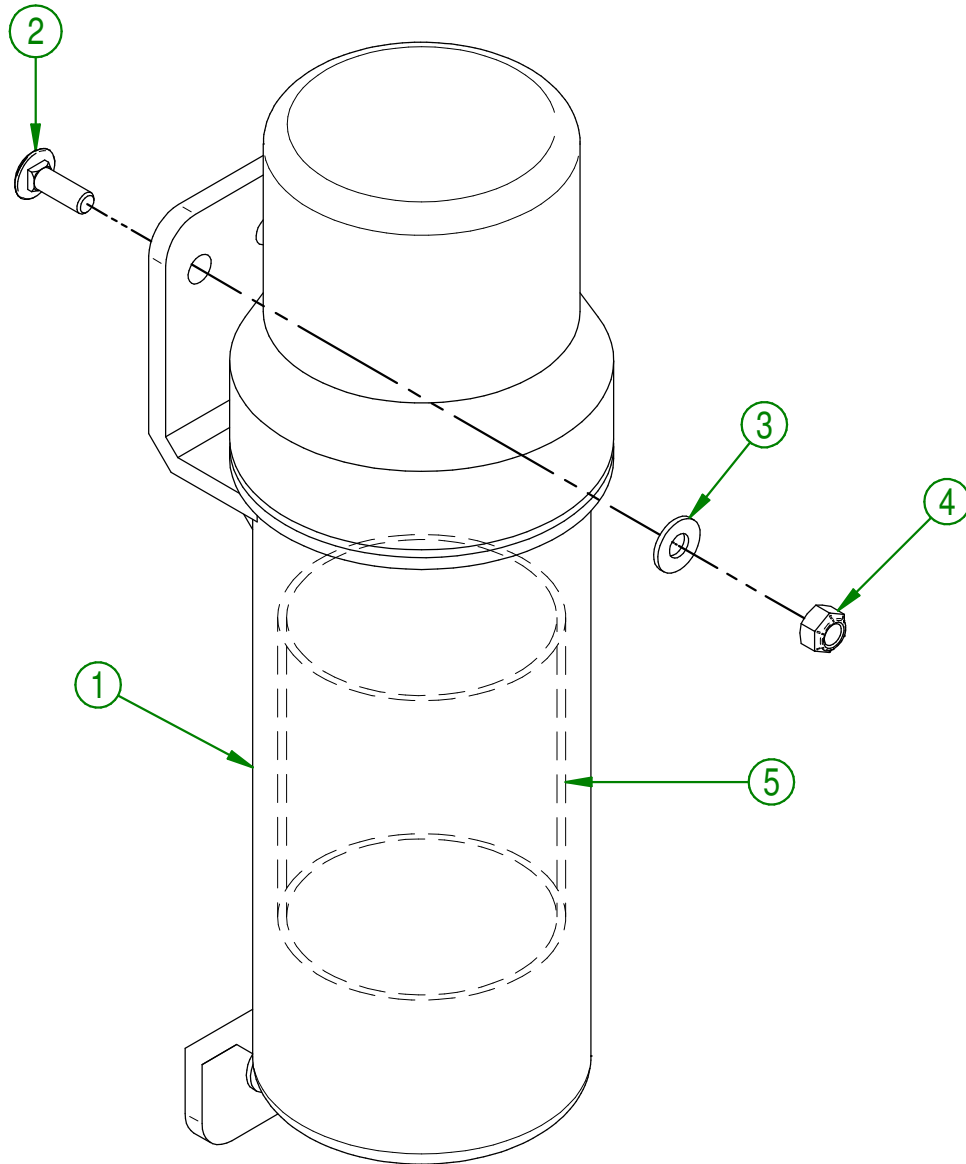

AGRIMETAL	
OPERATOR MANUEL TUBE ASSEMBLY	
CREATION : 14/02/18	ASSEMBLY : 33-57-2566
REVISION : 05/10/18	AUTHOR : J.KABWE

#	PART #	QTY	TITLE
1	NCI3-33-0052	2	STICKER FRAME LEVEL
2	NCI3-33-0192	2	STICKER (PROJECTION RISK)
3	NCI3-33-0185	1	STICKER PICTOGRAM (FIRE + CIGARETTE)
4	NCI3-33-2687	2	STICKER AGRIMETAL
5	NCI3-33-0178	1	STICKER IMPORTANT PLEASE CHECK OIL LEVEL...
6	NCI3-33-2674	2	STICKER TO PROGRAM REMOTE CONTROL
7	NCI3-33-0183	1	STICKER CAUTION OPERATION MANUAL
8	NCI3-33-0129	1	STICKER 101 DB
9	NCI3-33-0227	1	STICKER FUSE 15 AMP MAXIMUM

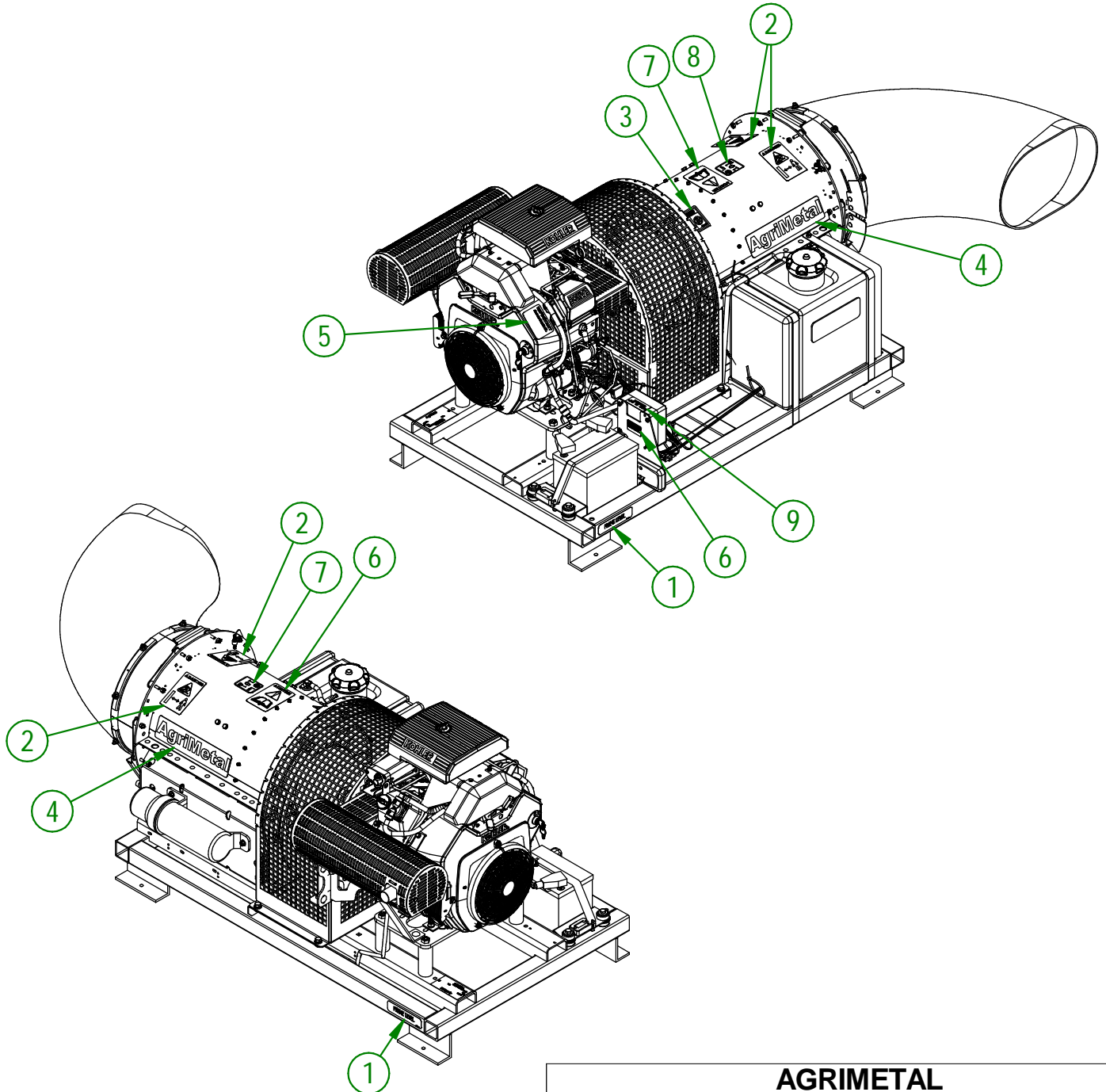
**AGRIMETAL****TURBINE BLOWER 270 IC-2**

CREATION : 09/07/25
 REVISION : 08/01/26

ASSEMBLY : **33-99-3003**
 AUTHOR : J.KABWE