

# AgriMetal

## PART LIST

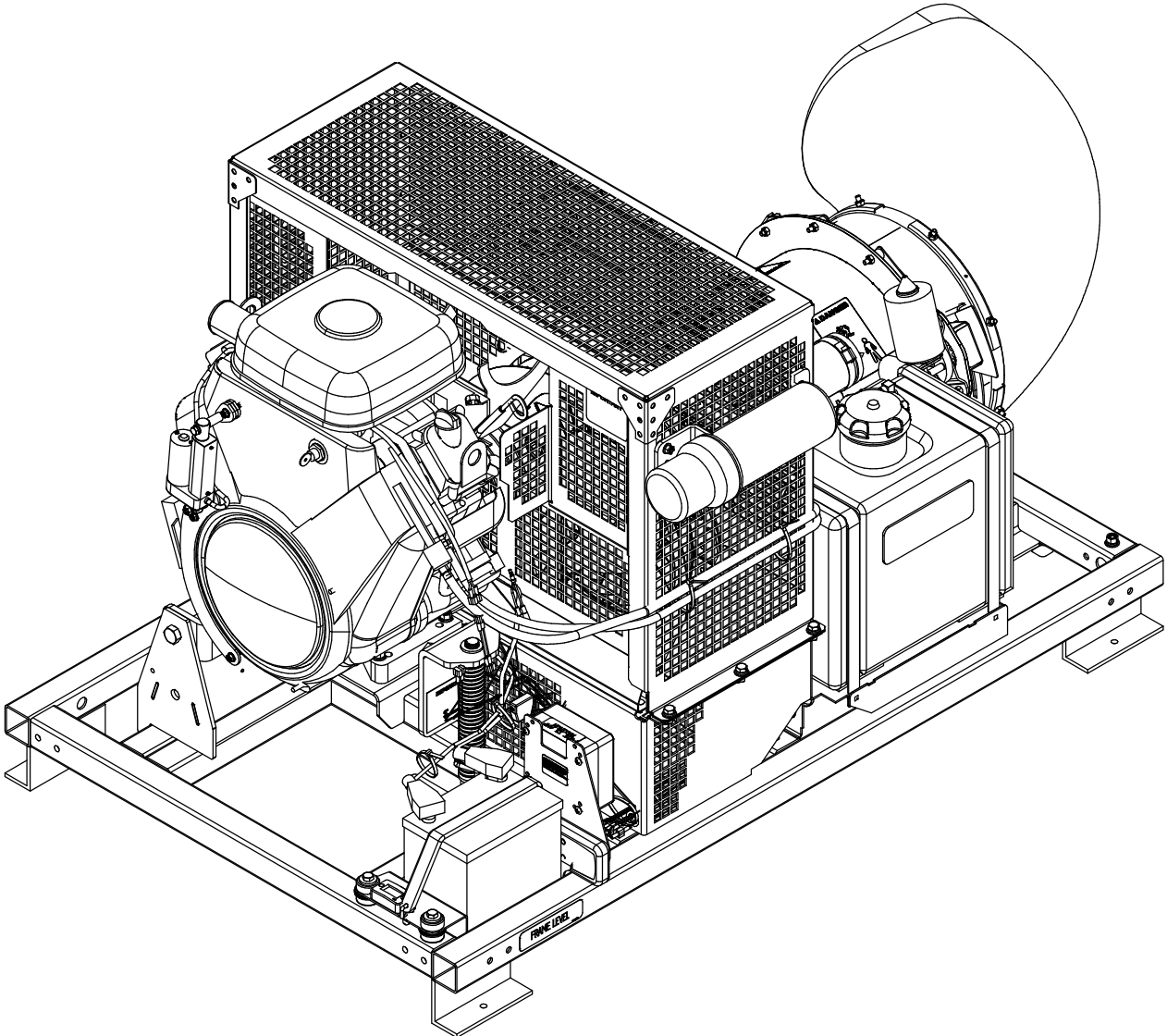

# TURBINE BLOWER 350 IC CARB

#	PART #	Qty	TITLE
1	33-01-1500	4	GAS TANK STRAP SUPPORT
2	33-01-3060	4	GAS TANK STRAP
3	33-01-3210	1	CARBON CAN SUPPORT
4	33-46-0536	1	GAS HOSE 1/4" ID X 1/2" OD X 6"
5	33-46-0536	1	1/2" DIA. X 1/4" DI X 6" GAS HOSE (TB-380 IC)
6	33-46-0537	1	GAS HOSE 1/4" ID X 1/2" OD X 32"
7	33-46-0566	1	7/16" DIA. X 3/16" DI X 44" GAS HOSE CARB (TB-350 IC)
8	33-46-0575	1	1/2" DIA. X 1/4" DI X 22" HOSE CARB (TB-380 IC)
9	33-46-0580	1	1/2" DIA X 1/4" DI X 15" HOSE CARB (TB-380 IC)
10	33-46-0665	1	GAS HOSE 1/4" ID X 1/2" OD X 39"
11	NC01-04-0002	4	CARR. BOLT GR2 ZINC 1/4-20 X 5/8"
12	NC01-65-0065	2	SNUG-FIT DAMPING LOOP CLAMP 2 5/16"- 3 1/4" HAS44
13	NC01-65-0201	6	SPRING -GRIP HOSE CLAMPS 1/2" O.D
14	NC01-96-0009	8	NYLON-INSERT LOCKNUT ZINC 1/4-20
15	NCI3-25-0019	3	BLACK TIE RAP
16	NCI3-65-0065	1	BARBED HOSE REDUCER 1/4" X 3/16"
17	NCI3-68-0025	2	T UNION 1/4" DI
18	NCI3-80-0247	2	GAS CAP
19	NCI3-80-0258	1	6 GALLON GAS CARBONE CAN
20	NCI3-80-0265	2	GROMMET VITRON #46866I
21	NCI3-80-0266	2	1/4" ON-OFF GAS VALVE

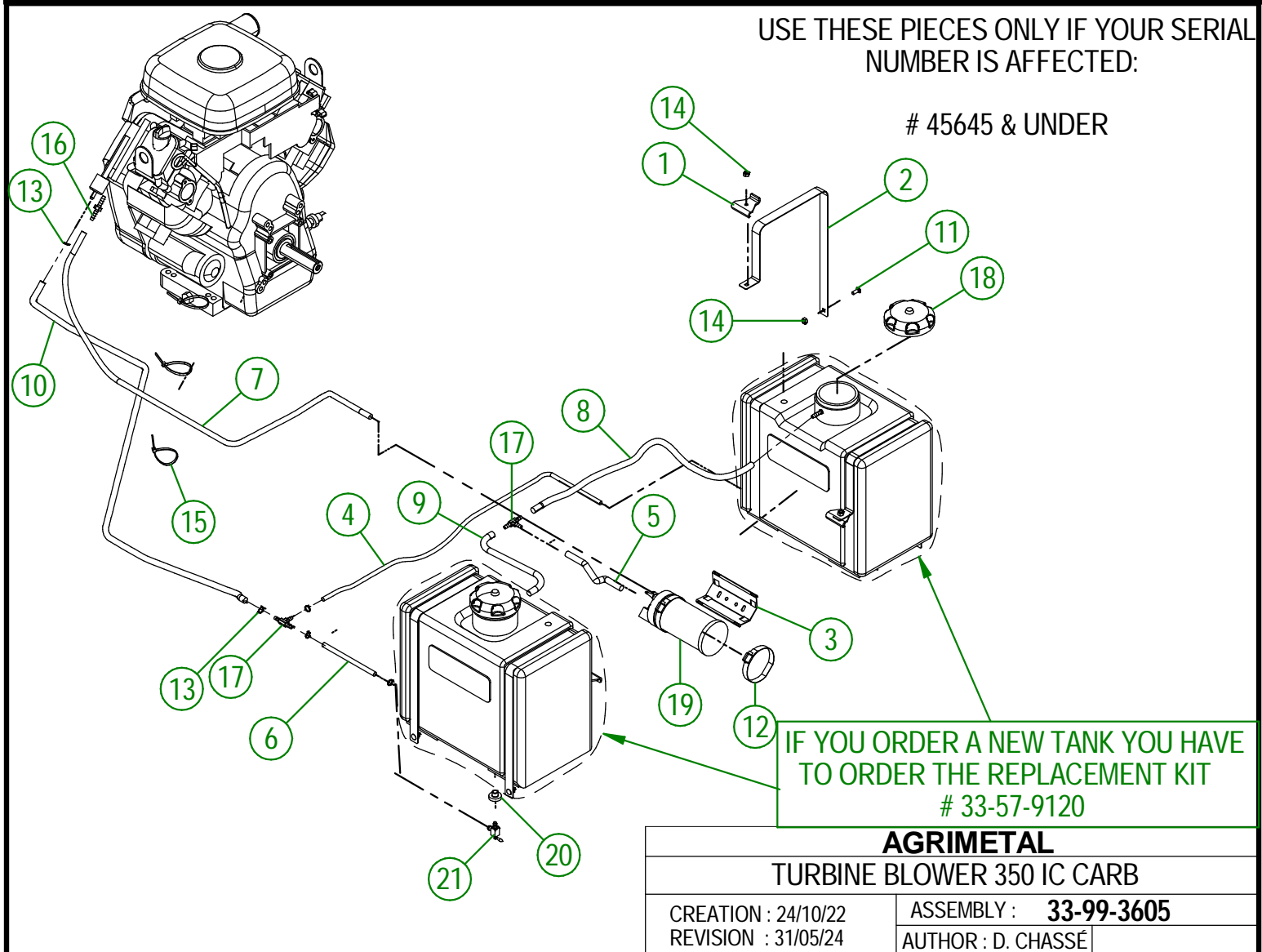

#	PART #	Qty	TITLE
1	33-01-1500	4	GAS TANK STRAP SUPPORT
2	33-01-3060	4	GAS TANK STRAP
3	33-01-3210	1	CARBON CAN SUPPORT
4	33-46-0536	1	1/2" DIA. X 1/4" DI X 6" GAS HOSE (TB-380 IC)
5	33-46-0566	1	7/16" DIA. X 3/16" DI X 44" GAS HOSE CARB (TB-350 IC)
6	33-46-0575	1	1/2" DIA. X 1/4" DI X 22" HOSE CARB (TB-380 IC)
7	33-46-0580	1	1/2" DIA X 1/4" DI X 15" HOSE CARB (TB-380 IC)
8	33-46-0700	1	1/4" GAS LINE X 23" LG
9	33-46-0705	1	1/4" GAS LINE X 11 1/2" LG
10	33-46-0710	1	1/4" GAS LINE X 29" LG
11	33-55-0200	1	GAS TANK
12	33-55-0205	2	GAS CAP
13	NC01-04-0002	4	CARR. BOLT GR2 ZINC 1/4-20 X 5/8"
14	NC01-65-0065	2	SNUG-FIT DAMPING LOOP CLAMP 2 5/16"- 3 1/4" HAS44
15	NC01-65-0201	6	SPRING -GRIP HOSE CLAMPS 1/2" O.D
16	NC01-96-0009	8	NYLON-INSERT LOCKNUT ZINC 1/4-20
17	NCI3-25-0019	6	BLACK TIE RAP
18	NCI3-37-0689	1	1/4" 3 WAY VALVE
19	NCI3-65-0065	1	BARBED HOSE REDUCER 1/4" X 3/16"
20	NCI3-68-0025	1	T UNION 1/4" DI
21	NCI3-80-0258	1	6 GALLON GAS CARBONE CAN

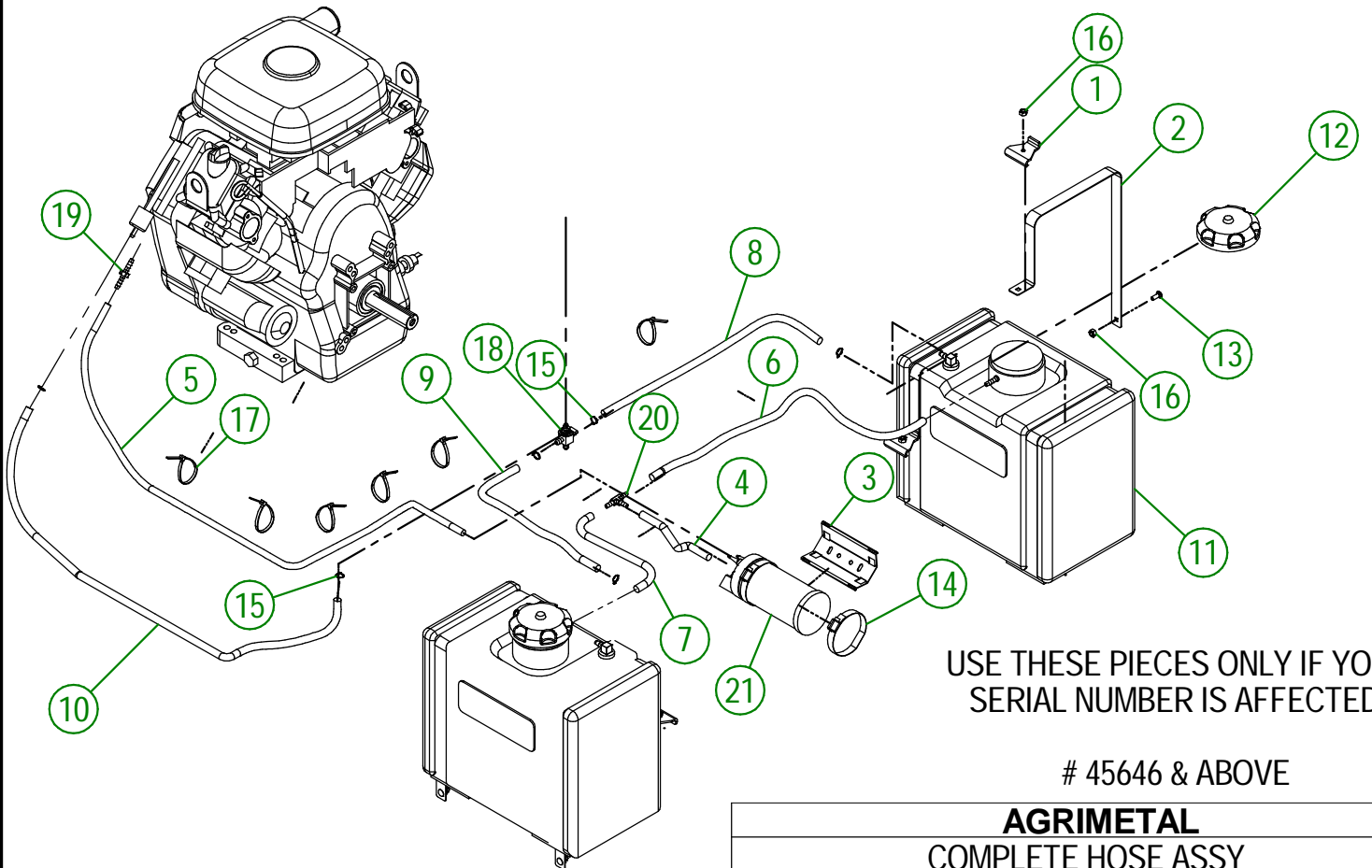

USE THESE PIECES ONLY IF YOUR  
SERIAL NUMBER IS AFFECTED:

# 45646 & ABOVE

**AGRIMETAL**  
COMPLETE HOSE ASSY

CREATION : 31/05/24  
REVISION : 21/08/25

ASSEMBLY : **33-57-0725**  
AUTHOR : D. CHASSÉ

#	PART #	QTY	TITLE
1	33-22-2240	1	WIRE PROTECTOR
2	NC02-42-0096	4	PHILLIPS SCREW ZINC #14 X 5/8"
3	NC13-25-0019	11	BLACK TIE RAP
4	NC13-25-0251	2	MICRO SWITCH BODY
5	NC13-25-0252	2	MICRO SWITCH HEAD
6	NC13-25-0253	2	MICRO SWITCH ROD ADAPTOR
7	NC13-25-0012	2	CONNECTOR "SKINTIGHT" (NYLON) 1/2 NPT X 0.200-0.470"
8	NC02-40-0081	4	SCREW ZINC 10-24 X 5/8"
9	NC01-96-0006	4	NYLON NUT ZINC 3/16
10	33-55-0515	1	18 GA ELECTRIC WIRE 600V (MICRO SWITCH) ASSY.
11	NC13-25-0233	2	VINYLE PROTECTOR COLLAR
12	NC13-25-0372	1	MANETTE TB-230 (NEW STYLE)
13	NC13-25-0370	1	ELECTRIC BOX TB 380
14	NC13-25-0375	1	67" NEW BOX WIRE

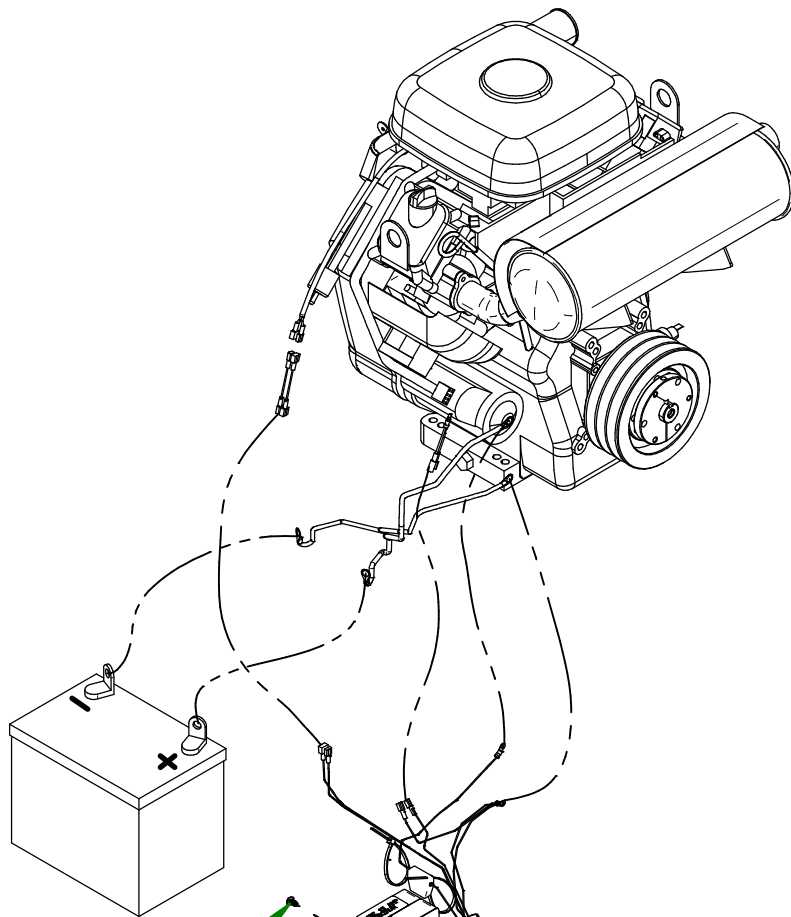

USE THESE PIECES ONLY IF YOUR SERIAL NUMBER IS AFFECTED:

#45955 AND BELOW

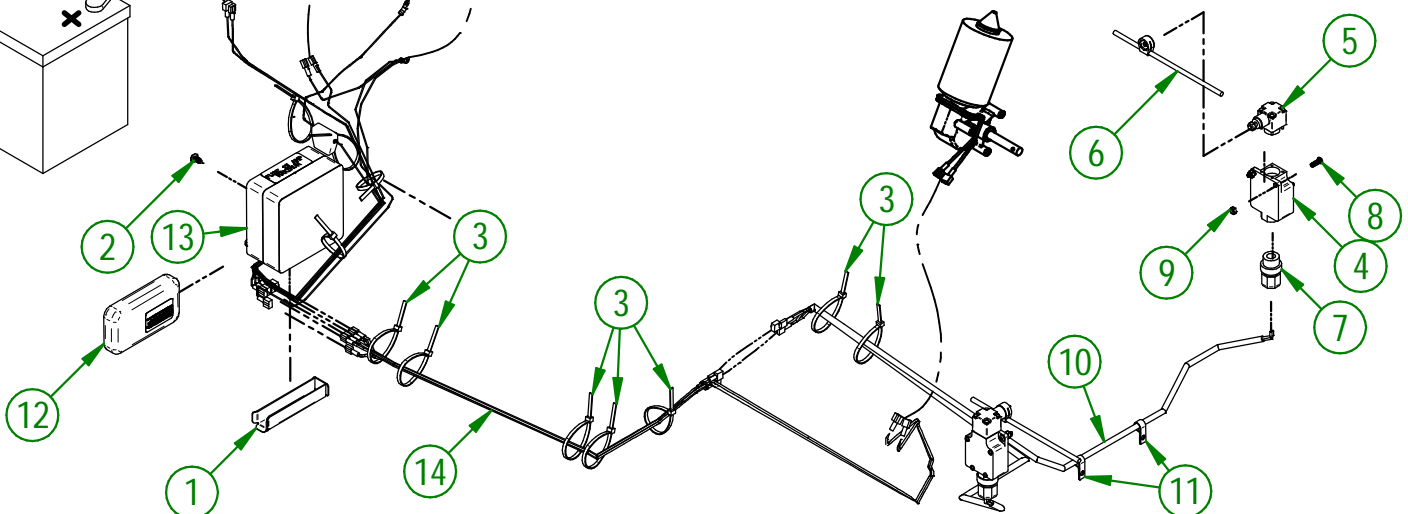

**AGRIMETAL**  
ELECTRIC WIRE GROUP.

CREATION : 26/06/24  
REVISION : 26/06/24

ASSEMBLY : **33-57-0655**  
AUTHOR : D. CHASSÉ

TURBINE BLOWER 270 IC  
TURBINE BLOWER 350 IC

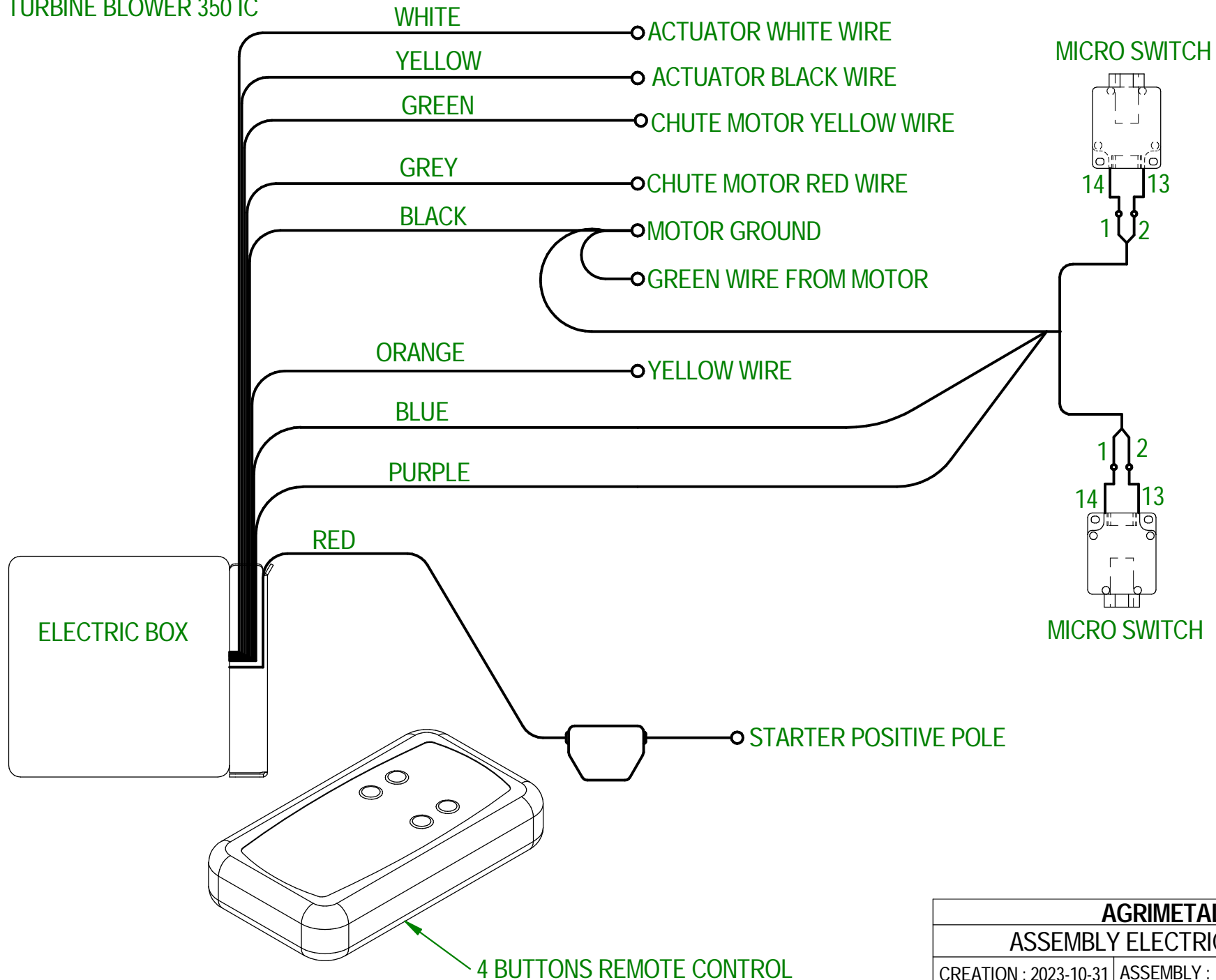

<b>AGRIMETAL</b>	
<b>ASSEMBLY ELECTRIC CONTROL</b>	
CREATION : 2023-10-31	ASSEMBLY : <b>33-57-0506</b>
REVISION : 2024-02-12	AUTHOR : D. CHASSÉ

#	PART #	QTY	TITLE
1	33-22-2240	1	WIRE PROTECTOR
2	NC02-42-0096	4	PHILLIPS SCREW ZINC #14 X 5/8"
3	NC13-25-0019	9	BLACK TIE RAP
4	33-55-0620	1	16 GA WIRE ASSY (PROXIMITY SENSOR)
5	NC13-25-0375	1	67" NEW BOX WIRE
6	NC13-25-0370	1	ELECTRIC BOX TB 380
7	NC13-25-0233	2	VINYLE PROTECTOR COLLAR
8	NC13-25-0408	1	PROXIMITY SENSOR (LEFT)
9	NC13-25-0408	1	PROXIMITY SENSOR (RIGHT)

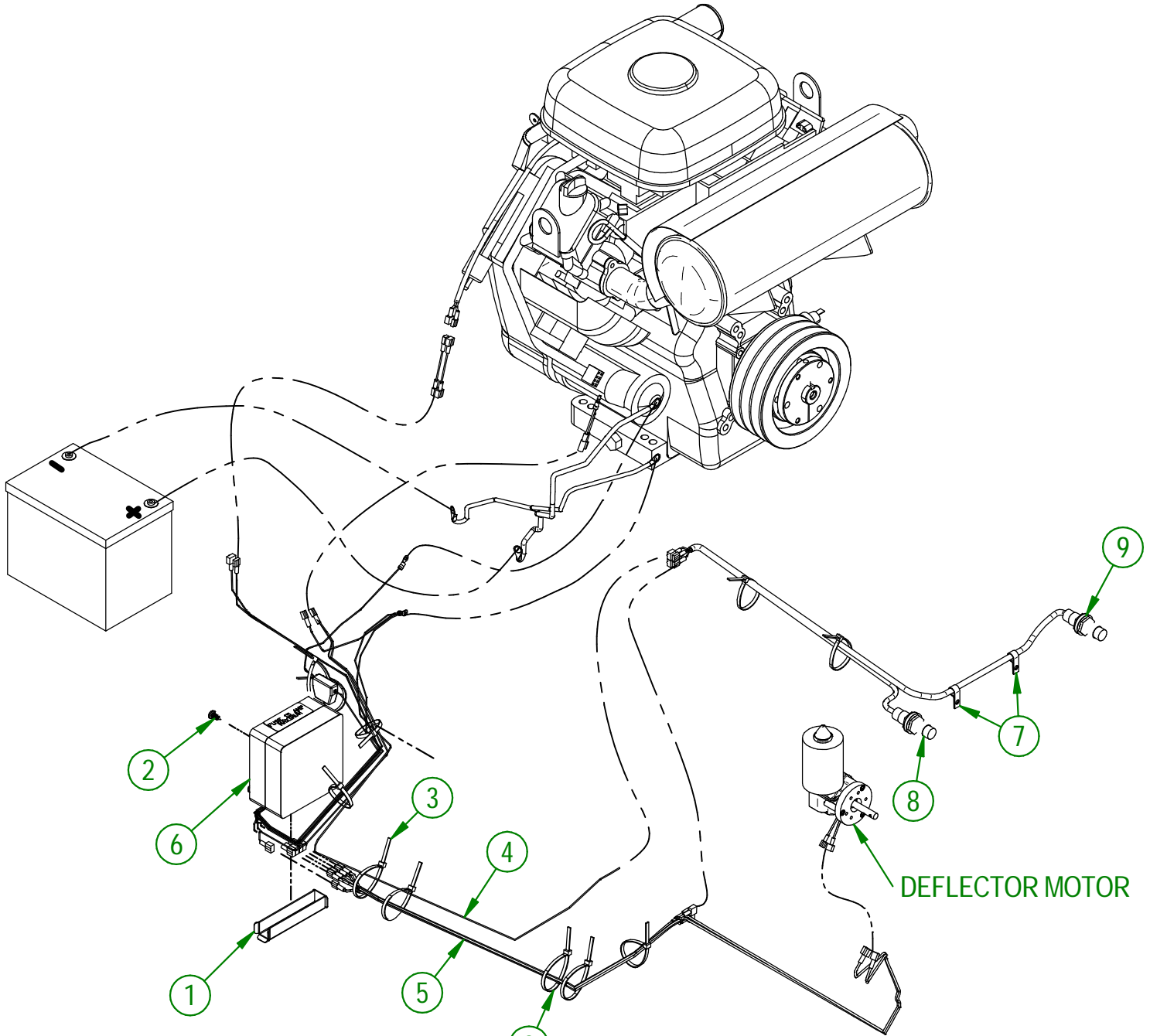

USE THESE PIECES ONLY IF YOUR SERIAL NUMBER IS AFFECTED:

# 45956 & ABOVE

<b>AGRIMETAL</b>	
<b>ASSEMBLY ELECTRIC CONTROL</b>	
CREATION : 27/06/24	ASSEMBLY : <b>33-57-0507</b>
REVISION : 08/07/25	AUTHOR : D. CHASSÉ

TURBINE BLOWER 350 IC

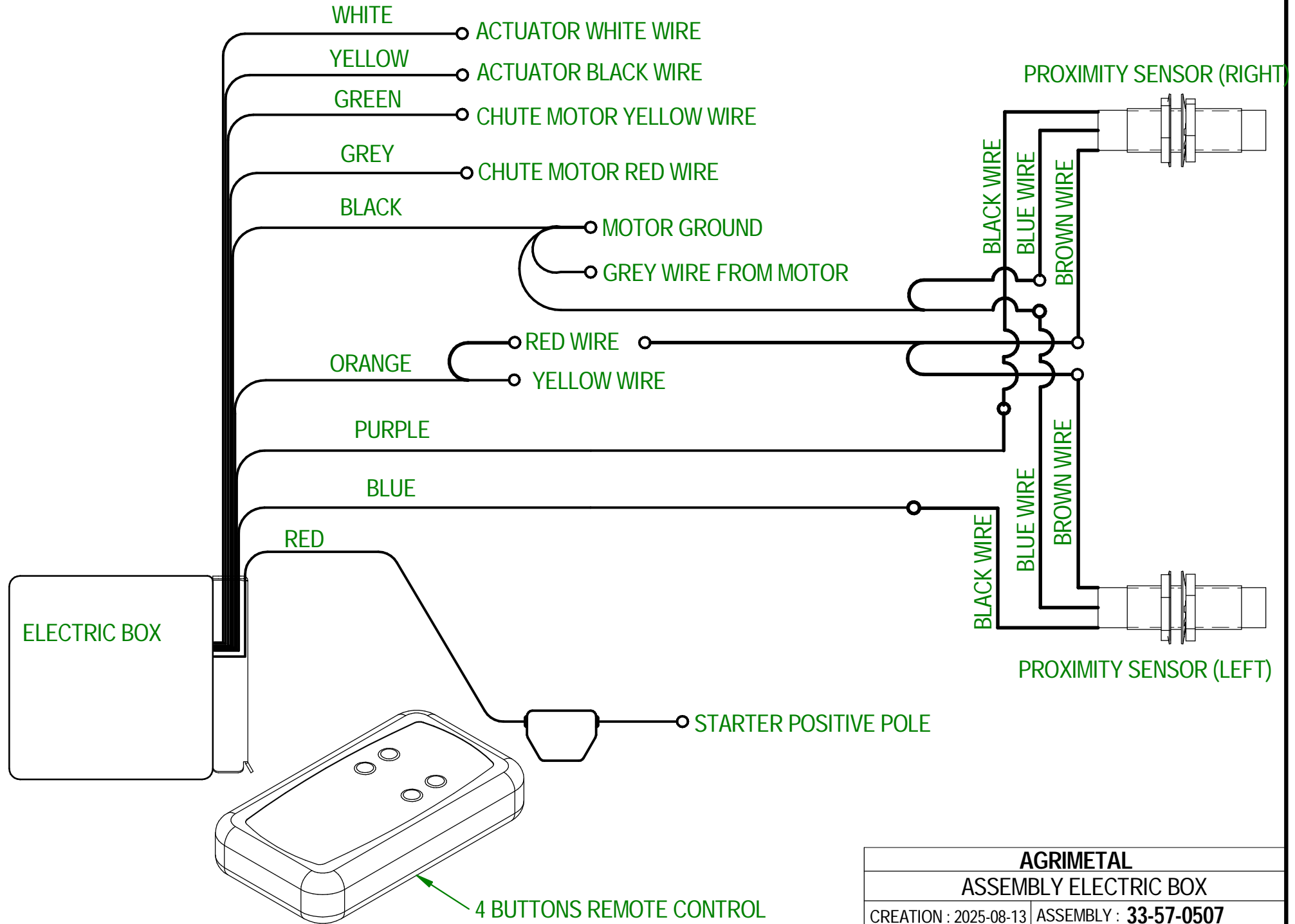

<b>AGRIMETAL</b>	
ASSEMBLY ELECTRIC BOX	
CREATION : 2025-08-13	ASSEMBLY : <b>33-57-0507</b>
REVISION : 2025-11-19	AUTHOR : D. CHASSÉ

33-57-0631

#	PART #	QTY	TITLE
1	33-55-2610	1	BELT GUARD (RIBBON INCLUDED)
2	NC01-17-0112	6	HEX. BOLT GR2 ZINC 3/8-16 X 3/4"
3	NC02-25-0009	6	WASHER ZINC 0.406 = 13/32
4	NC02-32-0012	8	LOCK WASHER ZINC 3/8"
5	33-03-4805	1	BELT GUARD REINFORCING
6	NC01-04-0107	2	CARR. BOLT GR2 ZINC 3/8-16 X 3/4"
7	NC02-07-0018	2	HEX. NUT ZINC 3/8-16
8	33-55-0655	1	GRILL (TB350 IC)
9	40-22-2200	2	SPECIAL WASHER

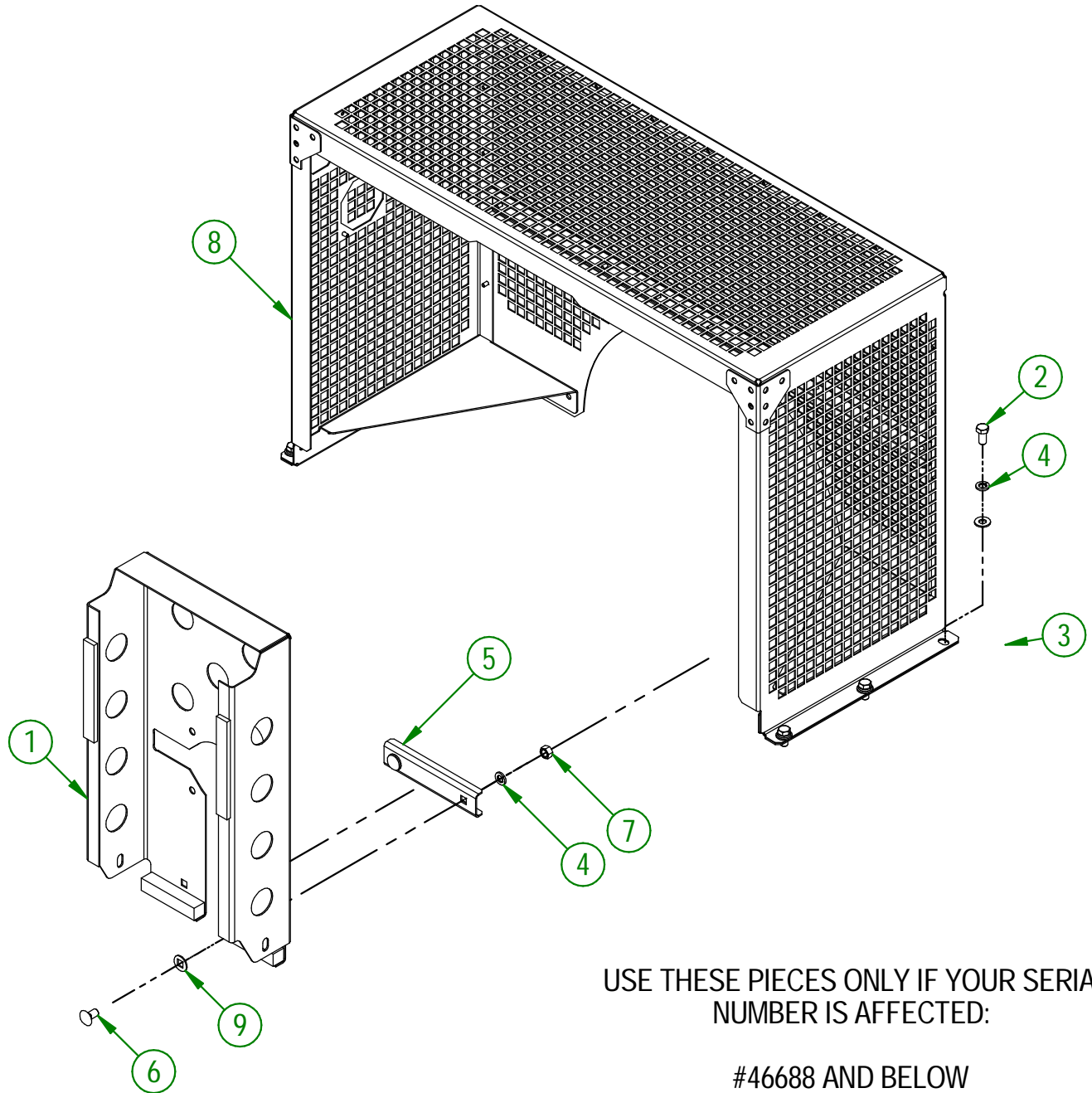

<b>AGRIMETAL</b>	
ASSEMBLY GUARD (TB 350 I.C.)	
CREATION : 29/09/22	ASSEMBLY : <b>33-57-0631</b>
REVISION : 27/11/24	AUTHOR : D. CHASSÉ

33-57-0632

#	PART #	Qty	TITLE
1	33-55-2611	1	BELT GUARD (RIBBON INCLUDED)
2	NC01-17-0112	6	HEX. BOLT GR2 ZINC 3/8-16 X 3/4"
3	NC02-25-0009	6	WASHER ZINC 0.406 = 13/32
4	NC02-32-0012	6	LOCK WASHER ZINC 3/8"
5	33-55-0655	1	GRILL (TB350 IC)

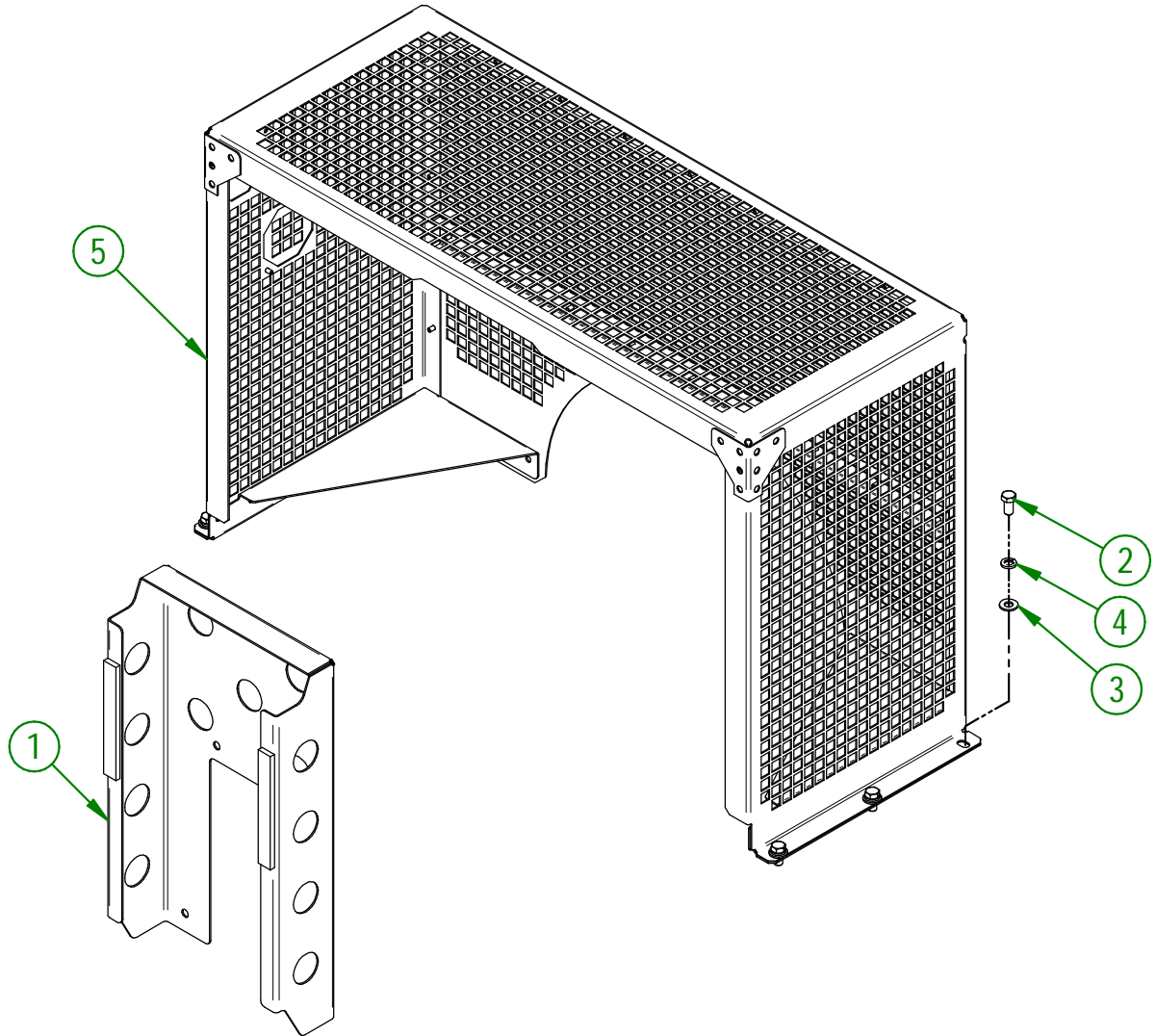

USE THESE PIECES ONLY IF YOUR SERIAL NUMBER IS AFFECTED:

#46689 AND ABOVE

<b>AGRIMETAL</b>	
ASSEMBLY GUARD (TB 350 I.C.)	
CREATION : 27/11/24	ASSEMBLY : <b>33-57-0632</b>
REVISION : 27/11/24	AUTHOR : D. CHASSÉ

#	PART#	QTY	TITLE
1	33-57-3500	1	FRAME GROUP
2	25-55-0710	1	SERIAL NUMBER PLATE
3	33-01-3071	1	SCRATCH PLATE
4	NC01-04-0109	6	CARR. BOLT GR2 ZINC 3/8-16 X 1"
5	NC02-25-0009	10	WASHER ZINC 0.406 = 13/32
6	NC02-32-0012	10	LOCK WASHER ZINC 3/8"
7	NC02-07-0018	10	HEX. NUT ZINC 3/8-16
8	NC01-04-0115	4	CARR. BOLT GR2 ZINC 3/8-16 X 2 1/2"

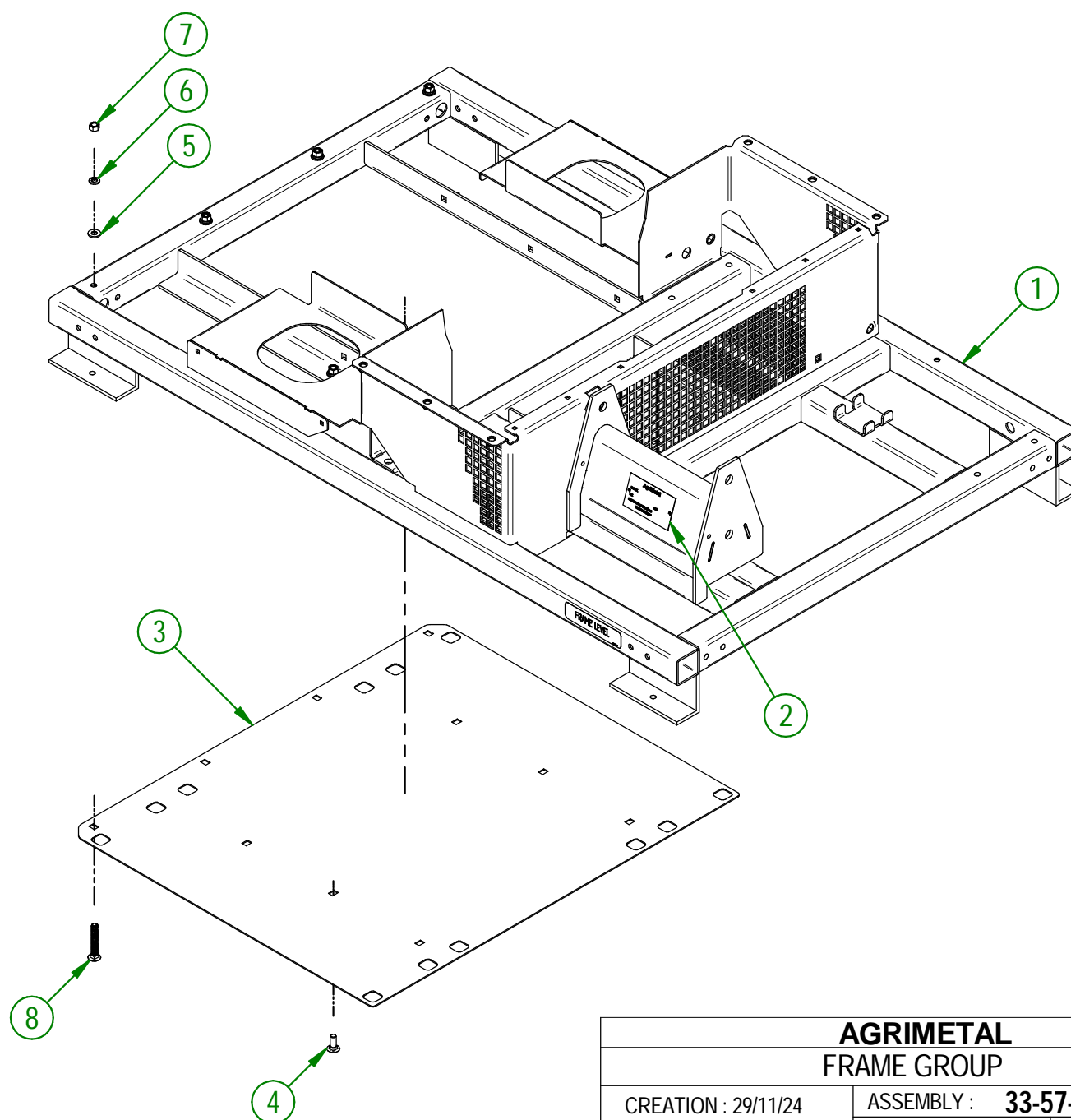

<b>AGRIMETAL</b>	
<b>FRAME GROUP</b>	
CREATION : 29/11/24	ASSEMBLY : <b>33-57-3400</b>
REVISION : 29/11/24	AUTHOR : D. CHASSÉ

#	PART#	QTY	TITLE
1	33-50-0505	1	ENGINE BASE
2	NC01-17-0396	2	HEX. BOLT GR2 ZINC 5/8-11 X 2"
3	NC02-22-0014	2	WASHER ZINC 11/16 ID X 1 3/4 OD
4	NC01-93-0016	2	LOCK NUT ZINC 5/8-11
5	33-57-0586	1	ASSEMBLY BELT TENSION
6	33-13-0005	2	ENGINE BASE BUSHING

33-57-0586

#	PART#	QTY	TITLE
7	33-50-0570	1	BELT TENSION
8	33-01-0975	1	TENSIONNER KEY
9	NC02-07-0023	1	HEX. NUT ZINC 3/4-10
10	22-04-6805	1	FLAT WASHER BEARING BASE
11	NC13-86-0083	1	BLUE SPRING 1/2" ID X 1" OD X 8"
12	33-42-0110	1	TENSIONNER GUIDE

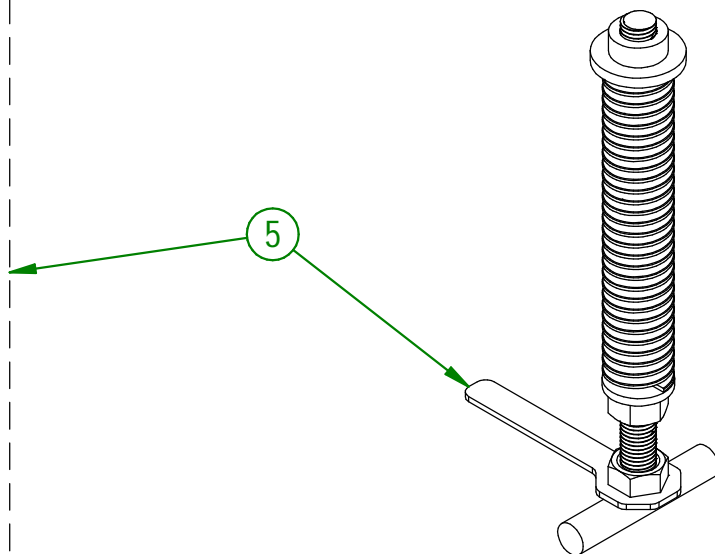
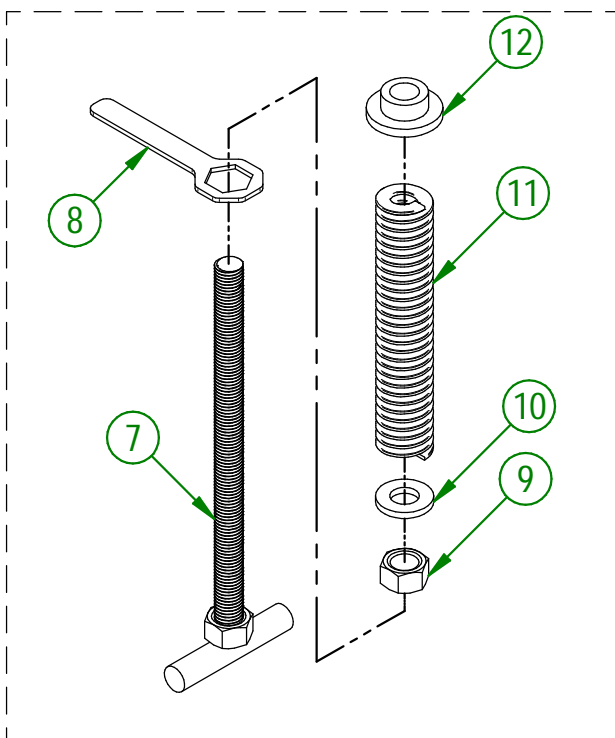
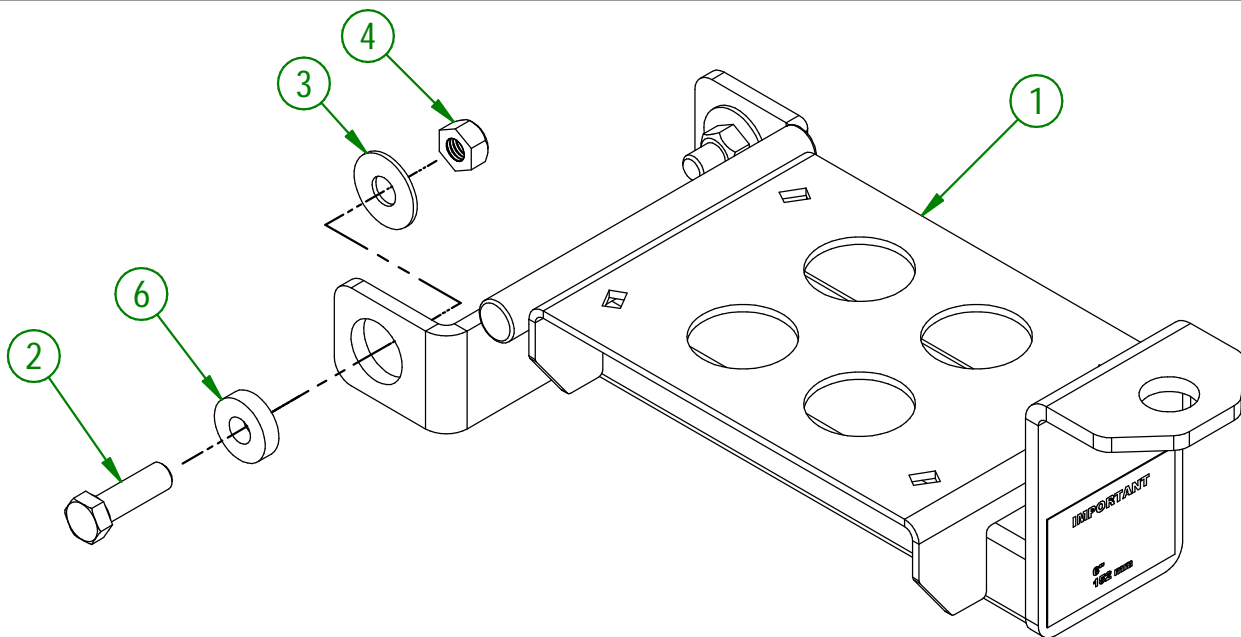

**AGRIMETAL**  
ENGINE BASE GROUP.

CREATION : 28/11/24  
REVISION : 28/11/24

ASSEMBLY : **33-57-0585**  
AUTHOR : J.KABWE

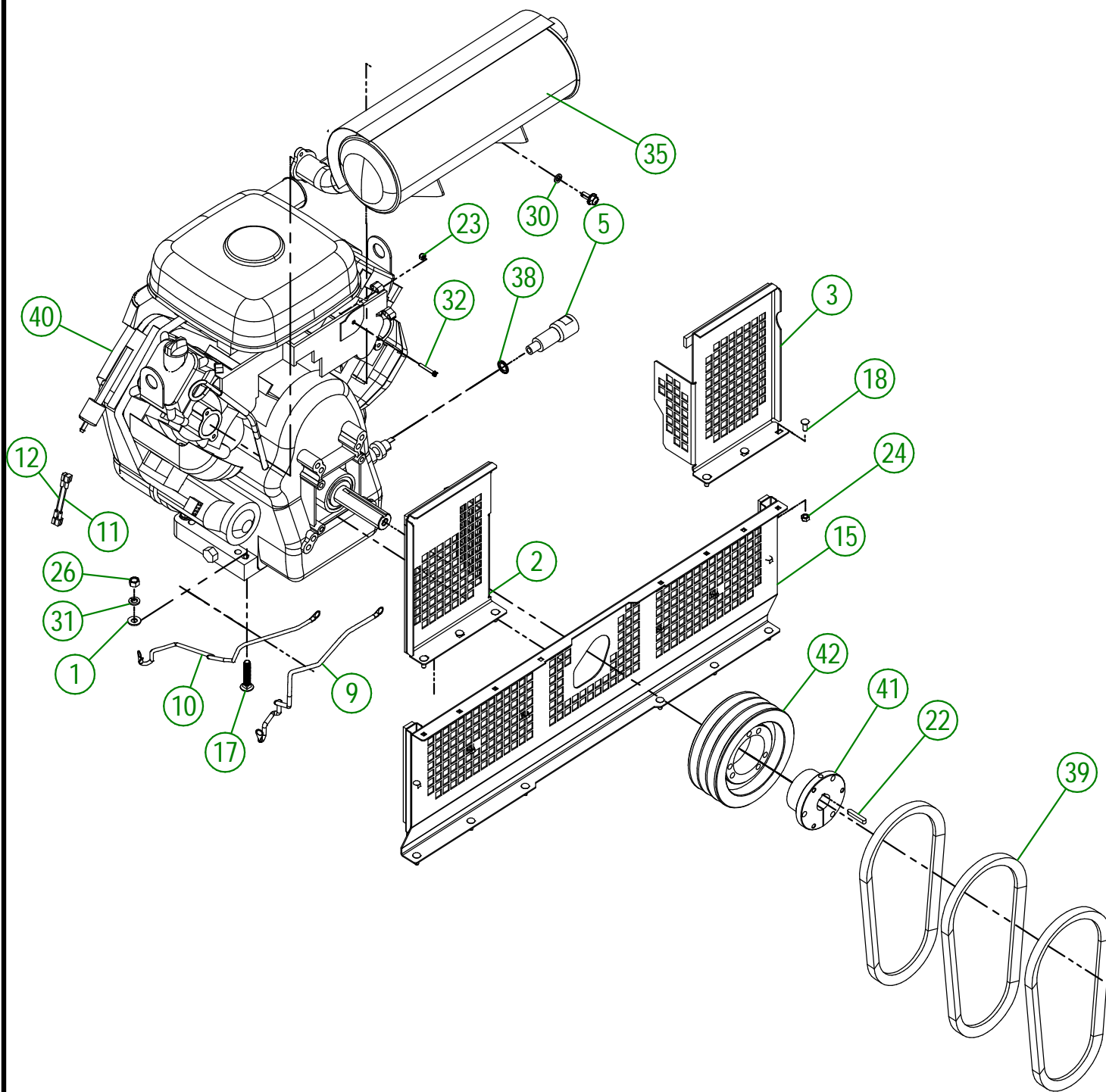

<b>AGRIMETAL</b>	
<b>ASSEMBLY VANGUARD ENGINE 35HP</b>	
CREATION : 06/10/22	ASSEMBLY : <b>33-57-0545</b>
REVISION : 26/11/25	AUTHOR : D. CHASSÉ

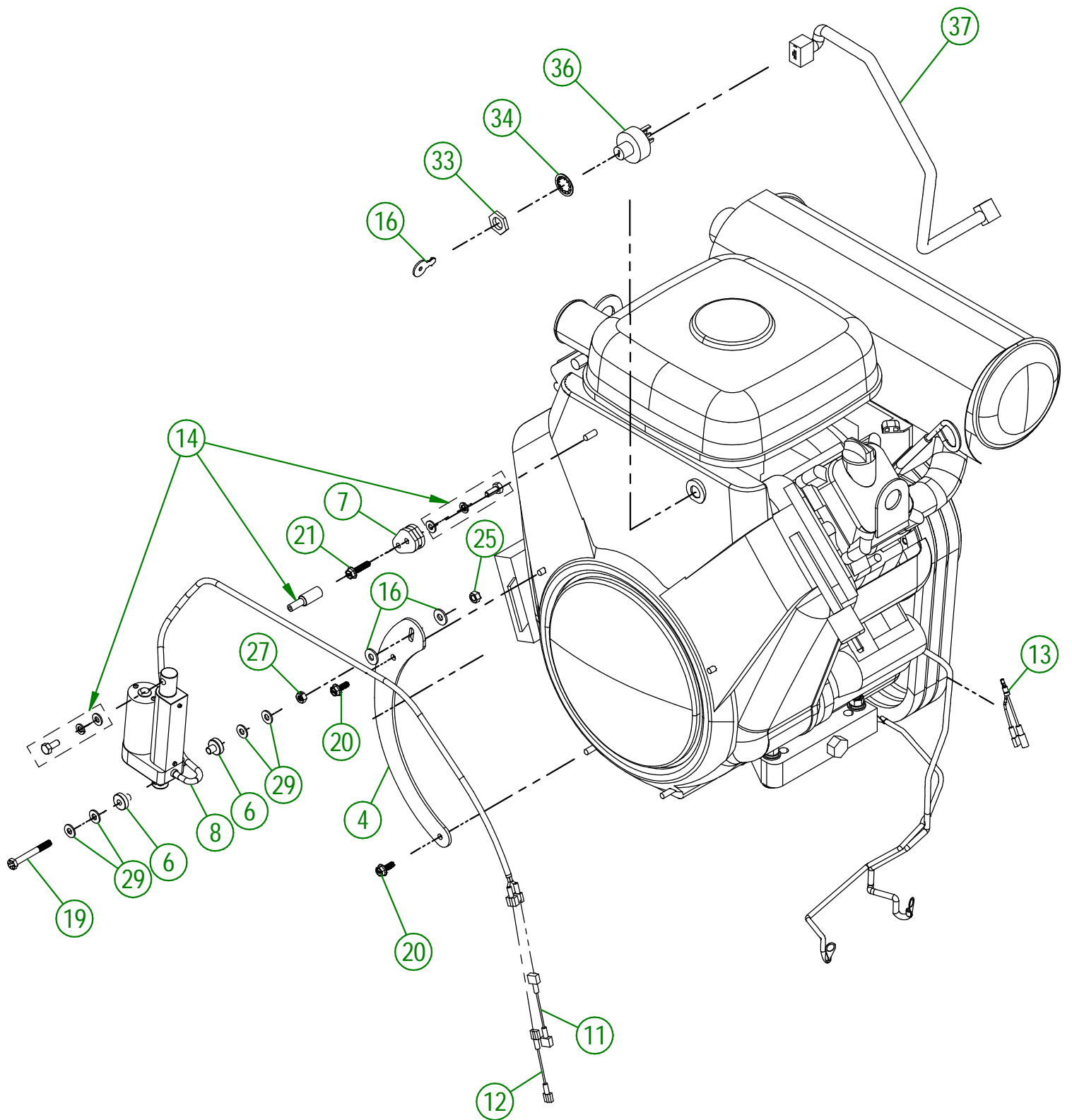

<b>AGRIMETAL</b>	
<b>ASSEMBLY VANGUARD ENGINE 35HP</b>	
CREATION : 06/10/22	ASSEMBLY : <b>33-57-0545</b>
REVISION : 26/11/25	AUTHOR : D. CHASSÉ

## 33-57-0545

#	PART #	Qty	TITLE
1	01-01-2485	8	FLAT WASHER 14 GA X 13/16"OD X 25/64" ID
2	33-01-0065	1	MUFFLER GUARD
3	33-01-0075	1	LEFT MUFFLER GUARD
4	33-01-0206	1	ACTUATOR SUPPORT
5	33-21-0125	1	MOTOR DRAIN EXTENSION
6	33-42-0120	2	PIVOT BUSHING
7	33-50-0200	1	ACTUATOR PIVOT LEVER
8	33-55-0100	1	PRE-ASS ACTUATOR 12V
9	33-55-0506	1	POSITIVE CABLE (14" LG)
10	33-55-0511	1	NEGATIVE CABLE (16" LG)
11	33-55-0610	1	16 GA YELLOW CABLE X 2" ASSY.
12	33-55-0615	1	16 GA WHITE CABLE X 2" ASSY.
13	33-55-0650	1	16 GA BLACK CABLE (Y FOR RECEIVER) HONDA
14	33-57-0107	1	ACTION ROD
15	33-57-0590	1	ASSEMBLY BOTTOM ENGINE GUARD
16	NC-13-37-0675	1	KEY SET
17	NC01-02-0113	4	CARR. BOLT GR2 ZINC 3/8-16 X 2"
18	NC01-04-0002	6	CARR. BOLT GR2 ZINC 1/4-20 X 5/8"
19	NC01-37-0011	1	HEX. BOLT GR8 1/4-28 X 2 1/4
20	NC01-50-1172	2	STEEL FLANGED HEX HEAD SCREW M6 X 0.75 X 16MM LG.
21	NC01-50-1172	1	STEEL FLANGED HEX HEAD SCREW M6 X 0.75 X 25MM LG
22	NC01-65-0087	1	KEY 1/4 X 1/4 X 1 1/2"
23	NC01-96-0004	1	8-32 JAM NUT
24	NC01-96-0009	6	NYLON-INSERT LOCKNUT ZINC 1/4-20
25	NC01-97-0004	1	NYLON-INSERT LOCKNUT ZINC 1/4-28
26	NC02-07-0018	4	HEX. NUT ZINC 3/8-16
27	NC02-14-1200	1	TWO WAY LOCK NUT 1/4-28
28	NC02-22-0008	2	WASHER ZINC 5/16"
29	NC02-25-0007	4	WASHER ZINC 0.281 = 9/32
30	NC02-32-0011	2	LOCK WASHER ZINC 5/16"
31	NC02-32-0012	8	LOCK WASHER ZINC 3/8"
32	NC02-50-0071	1	STAINLESS SOCKET HEAD SCREW 8-32 X 1 1/4"
33	NC13-37-0674	1	HEX NUT
34	NC13-37-0676	1	LOCK WASHER
35	NC13-37-0677	1	35 HP VANGUARD MUFFLER
36	NC13-37-0678	1	IGNITION SWITCH
37	NC13-37-0679	1	WIRE HARNESS ASS'Y
38	NC13-45-0392	1	METAL BOND SEALING WASHER 13.7MM ID X22.4MM OD
39	NC14-25-1070	3	V BELT 21/32 COGGED RAW EDGE BX-31
40	NC14-40-0051	1	VANGUARD ENGINE 35 HP ELECTRIC START
41	NC14-62-0004	1	QD BUSHING SD 1 1/8
42	NC14-62-0220	1	PULLEY QD 3V 1/2-5/8 X 6.75 OD X SD 3B64

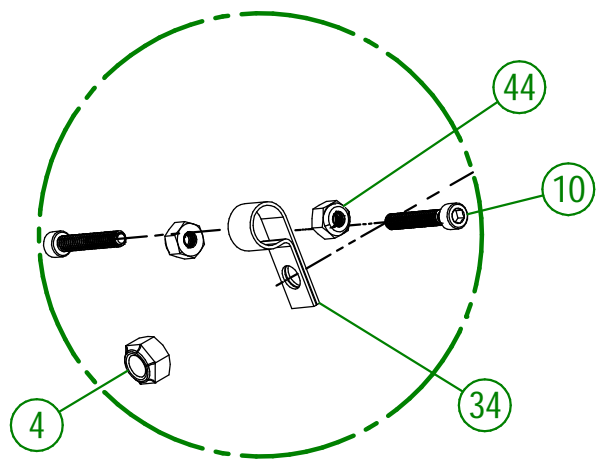
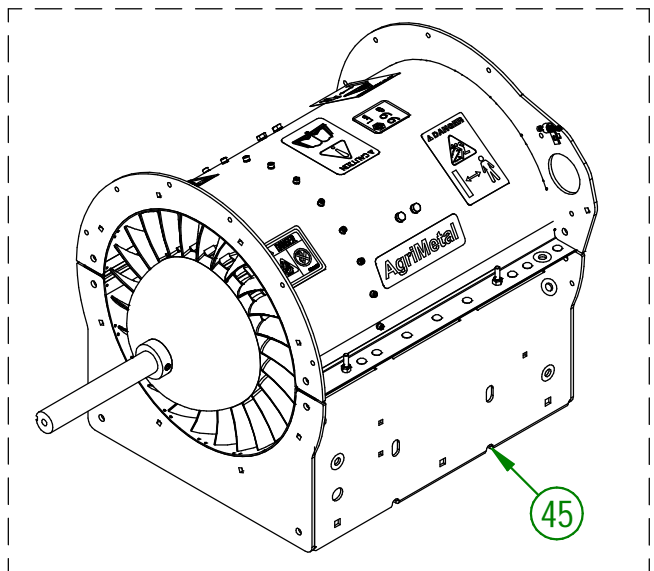

DETAIL A

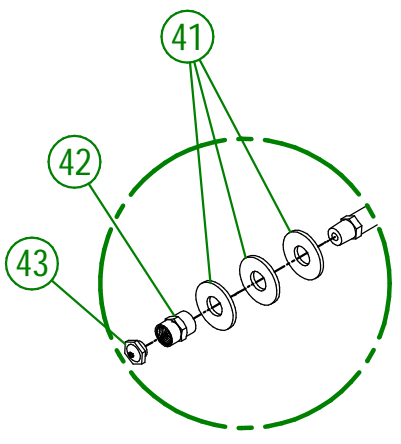

DETAIL C

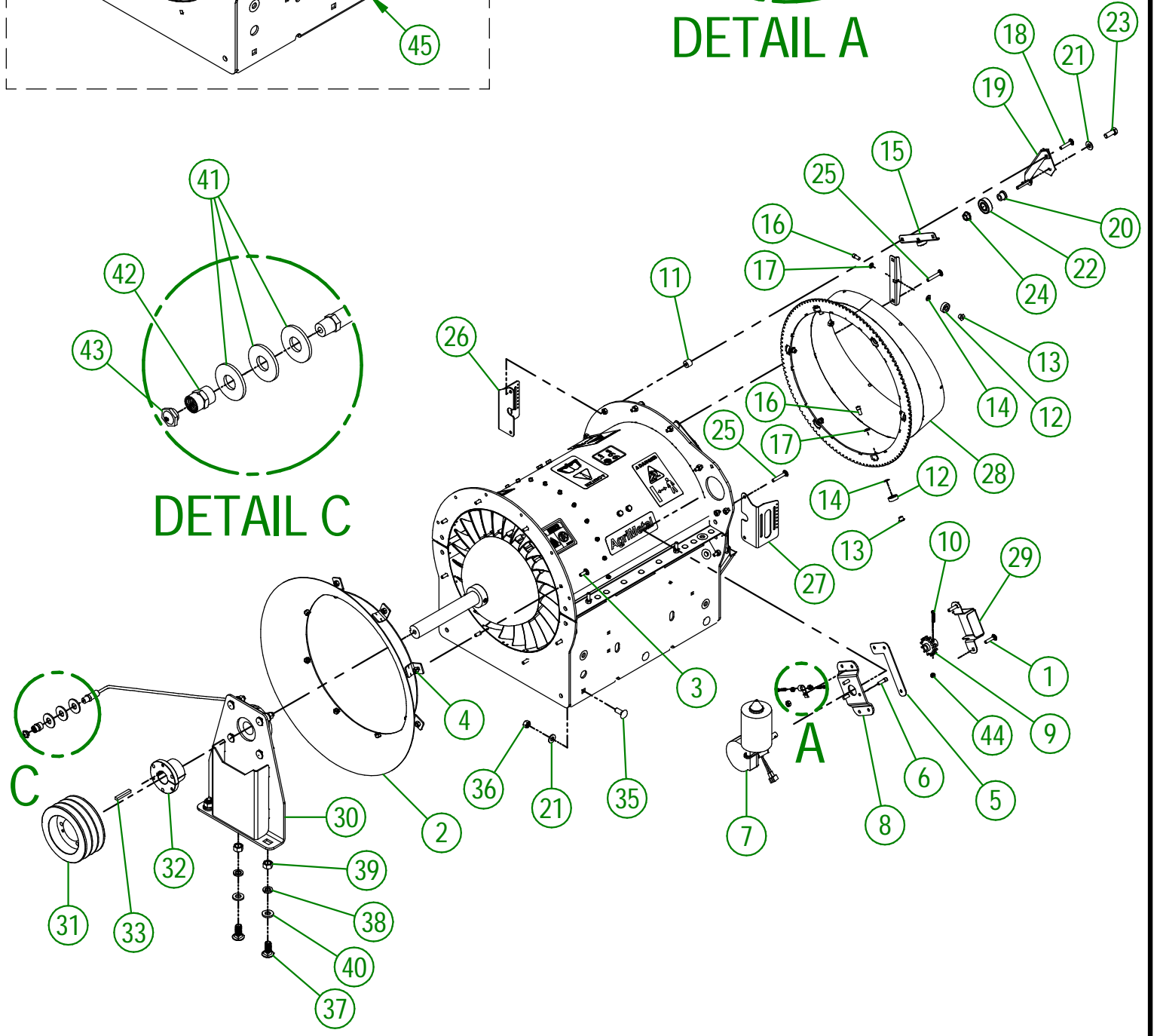

USE THESE PIECES ONLY IF YOUR SERIAL NUMBER IS AFFECTED:

#45955 AND BELOW

<b>AGRIMETAL</b>	
<b>ASSEMBLY TURBINE</b>	
CREATION : 28/06/24	ASSEMBLY : <b>33-57-0521</b>
REVISION : 10/10/24	AUTHOR : J.KABWE

33-57-0521

#	PART #	QT	TITLE
1	NC01-04-0005	6	CARR. BOLT GR2 ZINC 1/4-20 X 1"
2	33-55-0085	1	AIR INTAKE ASSY.
3	NC01-04-0003	8	CARR. BOLT GR2 ZINC 1/4-20 X 3/4"
4	NC01-96-0009	23	NYLON-INSERT LOCKNUT ZINC 1/4-20
5	33-01-2500	1	ELECTRIC ENGINE SHIM
6	NC02-51-0080	3	SOCKET CAP SCREW T.RON 1/4-28 X 3/4"
7	33-55-0045	1	DEFLECTOR ELECTRIC ENGINE
8	33-01-0933	1	ELECTRIC ENGINE SUPPORT
9	33-55-0035	1	GEARED CROWN SPROCKET
10	NC02-50-0069	3	SOCKET CAP SCREW T.RON 8-32 X 1"
11	33-21-0080	12	SPACER
12	NC14-75-0153	12	BALL BEARING R6 2RS 3/8" X 7/8" X 0.281"
13	33-25-2410	12	BEARING BUSHING
14	33-03-4605	12	BEARING SHIM 1/4" ALUMINUM
15	33-01-2425	6	BEARING HOLDER BRACKET
16	NC02-51-0578	12	SOCKET CAP SCREW T.RON. NF 1/4-28 X 1/2 STAINLESS
17	NC02-32-0010	12	LOCK WASHER ZINC 1/4"
18	NC01-04-0006	7	CARR. BOLT GR2 ZINC 1/4-20 X 1 1/4"
19	33-50-0555	3	WELD ASSEMBLY BEARING SUPPORT
20	33-21-0060	3	BEARING HOLDER
21	01-01-2485	9	FLAT WASHER 14 GA X 13/16"OD X 25/64" ID
22	NC14-75-0068	3	BALL BEARING 99502H
23	NC01-17-0114	3	HEX. BOLT GR2 ZINC 3/8-16 X 1"
24	NC02-14-0019	3	FLANGE NUT HEX. NC 3/8-16 GR. B
25	NC01-04-0007	5	CARR. BOLT GR2 ZINC 1/4-20 X 1 1/2"
26	33-01-2450	1	RIGHT MICRO SWITCH SUPPORT
27	33-01-2452	1	LEFT MICRO SWITCH SUPPORT
28	33-50-0515	1	WELD ASSEMBLY CROWN DEFLECTOR
29	33-01-3095	1	SPROCKET GUARD
30	33-55-0590	1	BEARING SUPPORT
31	NC14-62-0201	1	PULLEY QD 3V 1/2-5/8 X 5.55 OD X SD 3B52
32	NC14-62-0005	1	QD BUSHING SD 1 1/4"
33	33-41-0920	1	SQUARE KEY
34	NC13-25-0233	1	VINYLE PROTECTOR COLLAR
35	NC01-04-0109	6	CARR. BOLT GR2 ZINC 3/8-16 X 1"
36	NC01-93-0011	6	LOCK NUT 3/8-16
37	NC01-04-0234	3	CARR. BOLT GR2 ZINC 1/2-13 X 1 1/4
38	NC02-32-0014	3	LOCK WASHER ZINC 1/2"
39	NC02-07-0020	3	HEX. NUT ZINC 1/2-13
40	01-01-0925	3	WASHER
41	NC02-22-0012	3	WASHER ZINC 1/2 BOLT = 9/16"Ø X 1 3/8" OD
42	NC13-65-0001	1	UNION 1/4" NPT X 7/8"
43	NC01-69-0798	1	GREASE FITTING 1/4" NPT X RIGHT
44	NC01-96-0004	3	8-32 JAM NUT
45	33-57-0527	1	TRUBINE 380 IC (NEW)

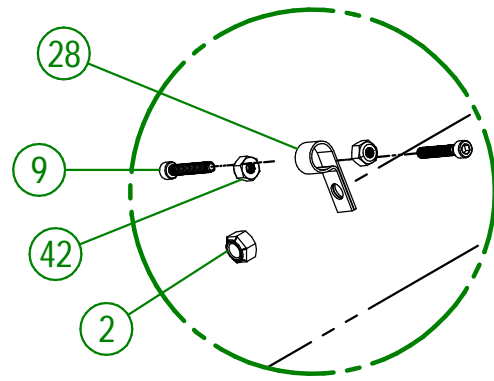
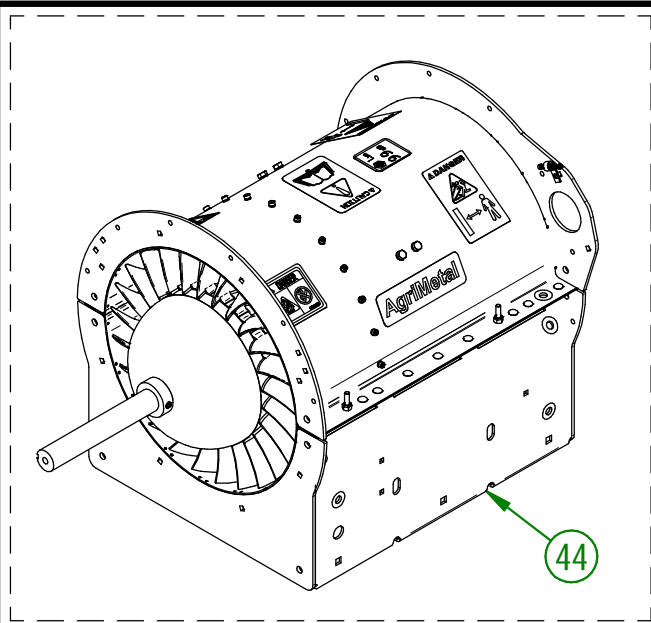

**DETAIL A**

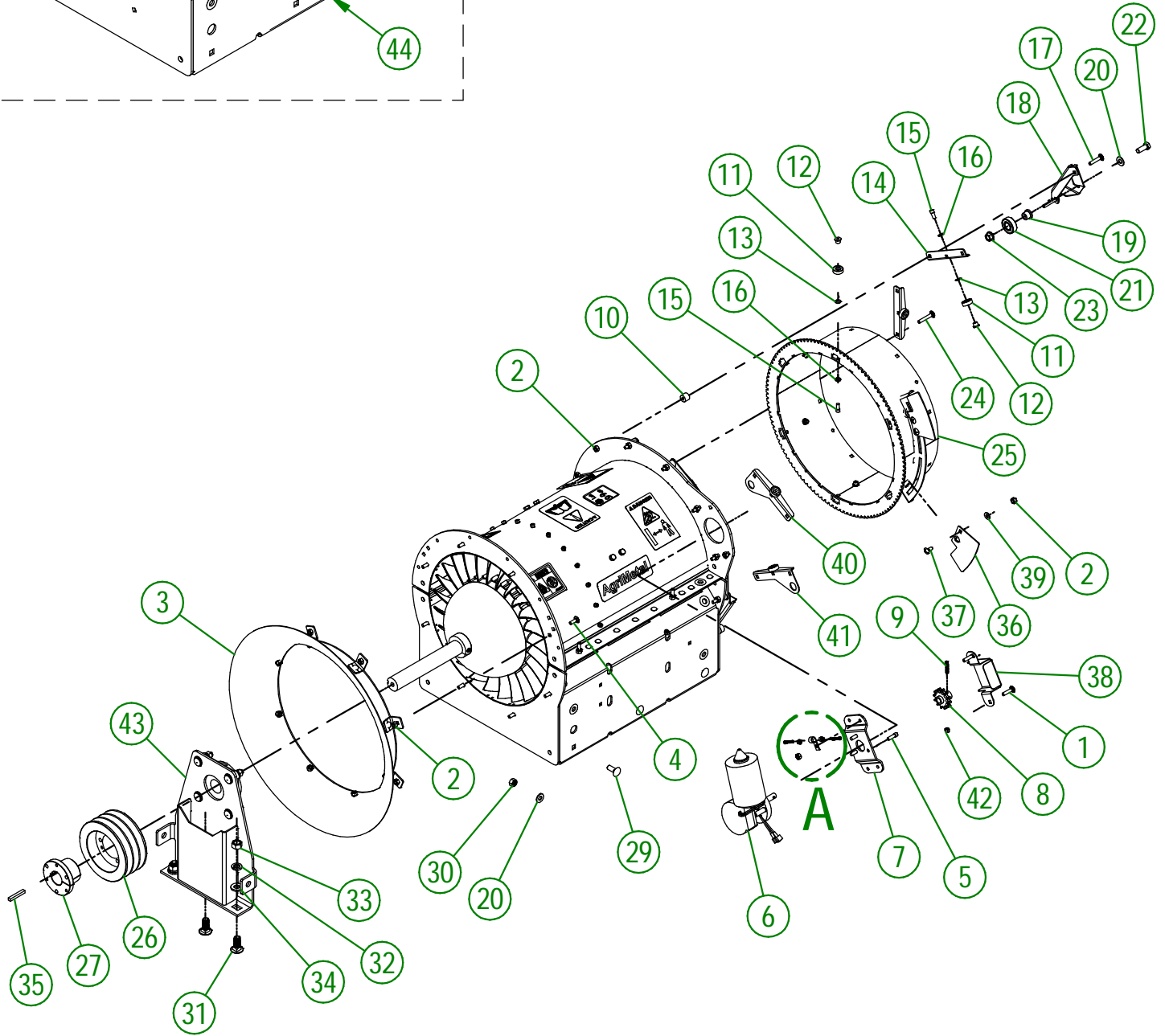

USE THESE PIECES ONLY IF YOUR SERIAL NUMBER IS AFFECTED:

BETWEEN #45956 & #46688

<b>AGRIMETAL</b>	
<b>ASSEMBLY TURBINE</b>	
CREATION : 28/06/24	ASSEMBLY : <b>33-57-0522</b>
REVISION : 03/02/25	AUTHOR : J.KABWE

33-57-0522

#	PART #	QTY	TITLE
1	NC01-04-0005	6	CARR. BOLT GR2 ZINC 1/4-20 X 1"
2	NC01-96-0009	48	NYLON-INSERT LOCKNUT ZINC 1/4-20
3	33-55-0085	1	AIR INTAKE ASSY.
4	NC01-04-0003	8	CARR. BOLT GR2 ZINC 1/4-20 X 3/4"
5	NC02-51-0080	3	SOCKET CAP SCREW T. RON 1/4-28 X 3/4"
6	33-55-0045	1	DEFLECTOR ELECTRIC ENGINE
7	33-01-0933	1	ELECTRIC ENGINE SUPPORT
8	33-50-2002	1	CROWN PINION
9	NC02-50-0069	3	SOCKET CAP SCREW T. RON 8-32 X 1"
10	33-21-0080	12	SPACER
11	NC14-75-0153	10	BALL BEARING R6 2RS 3/8" X 7/8" X 0.281"
12	33-25-2410	10	BEARING BUSHING
13	33-03-4605	10	BEARING SHIM 1/4" ALUMINUM
14	33-01-2425	4	BEARING HOLDER BRACKET
15	NC02-51-0578	10	SOCKET CAP SCREW T. RON. NF 1/4-28 X 1/2 STAINLESS
16	NC02-32-0010	10	LOCK WASHER ZINC 1/4"
17	NC01-04-0006	7	CARR. BOLT GR2 ZINC 1/4-20 X 1 1/4"
18	33-50-0555	3	WELD ASSEMBLY BEARING SUPPORT
19	33-21-0060	3	BEARING HOLDER
20	NC02-25-0009	9	FLAT WASHER 14 GA X 13/16"OD X 25/64" ID
21	NC14-75-0068	3	BALL BEARING 99502H
22	NC01-17-0114	3	HEX. BOLT GR2 ZINC 3/8-16 X 1"
23	NC02-14-0019	3	FLANGE NUT HEX. NC 3/8-16 GR. B
24	NC01-04-0007	5	CARR. BOLT GR2 ZINC 1/4-20 X 1 1/2"
25	33-50-0018	1	DUCT COLECTOR
26	NC14-62-0201	1	PULLEY QD 3V 1/2-5/8 X 5.55 OD X SD 3B52
27	NC14-62-0005	1	QD BUSHING SD 1 1/4"
28	NC13-25-0233	1	VINYLE PROTECTOR COLLAR
29	NC01-04-0109	6	CARR. BOLT GR2 ZINC 3/8-16 X 1"
30	NC01-93-0011	6	LOCK NUT 3/8-16
31	NC01-04-0234	3	CARR. BOLT GR2 ZINC 1/2-13 X 1 1/4
32	NC02-32-0014	3	LOCK WASHER ZINC 1/2"
33	NC02-07-0020	3	HEX. NUT ZINC 1/2-13
34	NC02-25-0011	3	WASHER SAE ZINC 17/32 ID
35	33-41-0920	1	SQUARE KEY
36	33-01-0370	2	ROTATION TRIGGER PLATE
37	NC01-07-0002	4	CARR. BOLT GR5 ZINC 1/4-20 X 5/8"
38	33-01-3095	1	SPROCKET GUARD
39	NC02-22-0008	6	WASHER ZINC 5/16"
40	33-55-0140	1	RIGHT LIMIT SWITCH & BEARING GUIDE ASSY.
41	33-55-0145	1	LEFT LIMIT SWITCH & BEARING GUIDE ASSY.
42	NC01-96-0004	3	8-32 JAM NUT
43	33-55-0590	1	BEARING SUPPORT
44	33-57-0527	1	TURBINE 380 IC (NEW)

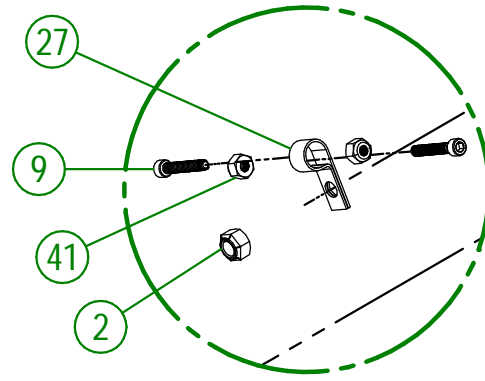
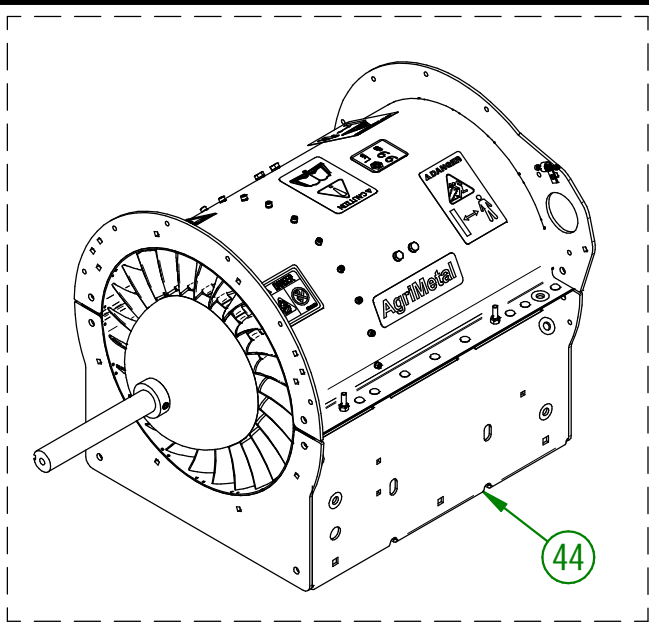

**DETAIL A**

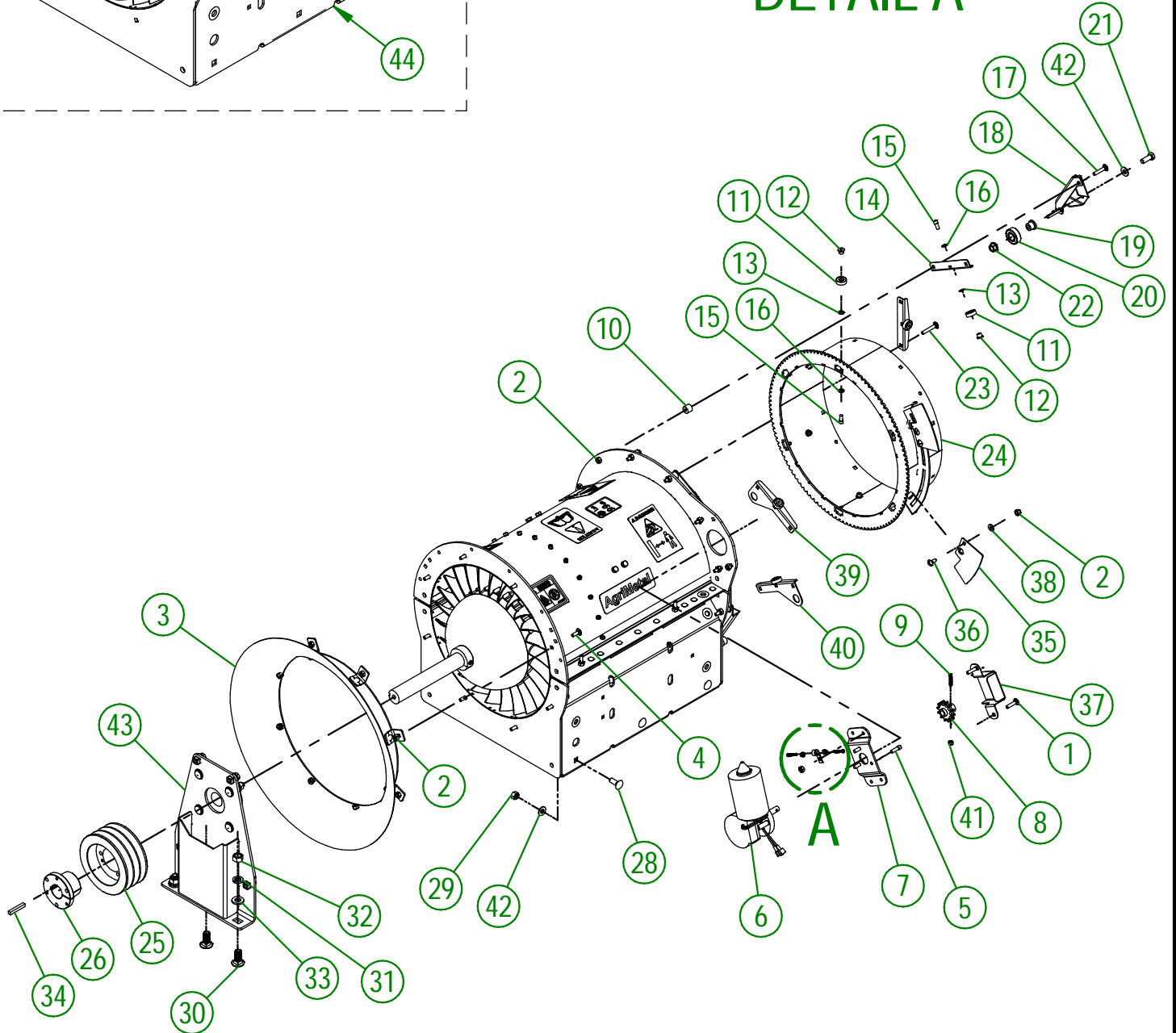

USE THESE PIECES ONLY IF YOUR SERIAL NUMBER IS AFFECTED:

#46689 & ABOVE

<b>AGRIMETAL</b>	
<b>ASSEMBLY TURBINE</b>	
CREATION : 27/11/24	ASSEMBLY : <b>33-57-0523</b>
REVISION : 03/02/25	AUTHOR : J.KABWE

33-57-0523

#	PART#	QTY	TITLE
1	NC01-04-0005	6	CARR. BOLT GR2 ZINC 1/4-20 X 1"
2	NC01-96-0009	48	NYLON-INSERT LOCKNUT ZINC 1/4-20
3	33-55-0085	1	AIR INTAKE ASSY.
4	NC01-04-0003	8	CARR. BOLT GR2 ZINC 1/4-20 X 3/4"
5	NC02-51-0080	3	SOCKET CAP SCREW T. RON 1/4-28 X 3/4"
6	33-55-0045	1	DEFLECTOR ELECTRIC ENGINE
7	33-01-0933	1	ELECTRIC ENGINE SUPPORT
8	33-50-2002	1	CROWN PINION
9	NC02-50-0069	3	SOCKET CAP SCREW T. RON 8-32 X 1"
10	33-21-0080	12	SPACER
11	NC14-75-0153	10	BALL BEARING R6 2RS 3/8" X 7/8" X 0.281"
12	33-25-2410	10	BEARING BUSHING
13	33-03-4605	10	BEARING SHIM 1/4" ALUMINUM
14	33-01-2425	4	BEARING HOLDER BRACKET
15	NC02-51-0578	10	SOCKET CAP SCREW T. RON. NF 1/4-28 X 1/2 STAINLESS
16	NC02-32-0010	10	LOCK WASHER ZINC 1/4"
17	NC01-04-0006	7	CARR. BOLT GR2 ZINC 1/4-20 X 1 1/4"
18	33-50-0555	3	WELD ASSEMBLY BEARING SUPPORT
19	33-21-0060	3	BEARING HOLDER
20	NC14-75-0068	3	BALL BEARING 99502H
21	NC01-17-0114	3	HEX. BOLT GR2 ZINC 3/8-16 X 1"
22	NC02-14-0019	3	FLANGE NUT HEX. NC 3/8-16 GR. B
23	NC01-04-0007	5	CARR. BOLT GR2 ZINC 1/4-20 X 1 1/2"
24	33-50-0018	1	DUCT COLECTOR
25	NC14-62-0201	1	PULLEY QD 3V 1/2-5/8 X 5.55 OD X SD 3B52
26	NC14-62-0005	1	QD BUSHING SD 1 1/4"
27	NC13-25-0233	1	VINYLE PROTECTOR COLLAR
28	NC01-04-0109	6	CARR. BOLT GR2 ZINC 3/8-16 X 1"
29	NC01-93-0011	6	LOCK NUT 3/8-16
30	NC01-04-0234	3	CARR. BOLT GR2 ZINC 1/2-13 X 1 1/4
31	NC02-32-0014	3	LOCK WASHER ZINC 1/2"
32	NC02-07-0020	3	HEX. NUT ZINC 1/2-13
33	NC02-25-0011	3	WASHER SAE ZINC 17/32 ID
34	33-41-0920	1	SQUARE KEY
35	33-01-0370	2	ROTATION TRIGGER PLATE
36	NC01-07-0002	4	CARR. BOLT GR5 ZINC 1/4-20 X 5/8"
37	33-01-3095	1	SPROCKET GUARD
38	NC02-22-0008	6	WASHER ZINC 5/16"
39	33-55-0140	1	RIGHT LIMIT SWITCH & BEARING GUIDE ASSY.
40	33-55-0145	1	LEFT LIMIT SWITCH & BEARING GUIDE ASSY.
41	NC01-96-0004	3	8-32 JAM NUT
42	NC02-25-0009	9	FLAT WASHER 14 GA X 13/16"OD X 25/64" ID
43	33-55-0591	1	BEARING SUPPORT
44	33-57-0527	1	TURBINE 380 IC (NEW)

33-57-3530

#	PART#	QTY	TITLE
1	33-42-0005	1	90° PLASTIC ELBOW
2	33-01-2480	4	DUCT CLAMP
3	NC01-04-0005	8	CARR. BOLT GR2 ZINC 1/4-20 X 1"
4	NC01-96-0009	8	NYLON-INSERT LOCKNUT ZINC 1/4-20
5	NC02-22-0008	8	WASHER ZINC 5/16"

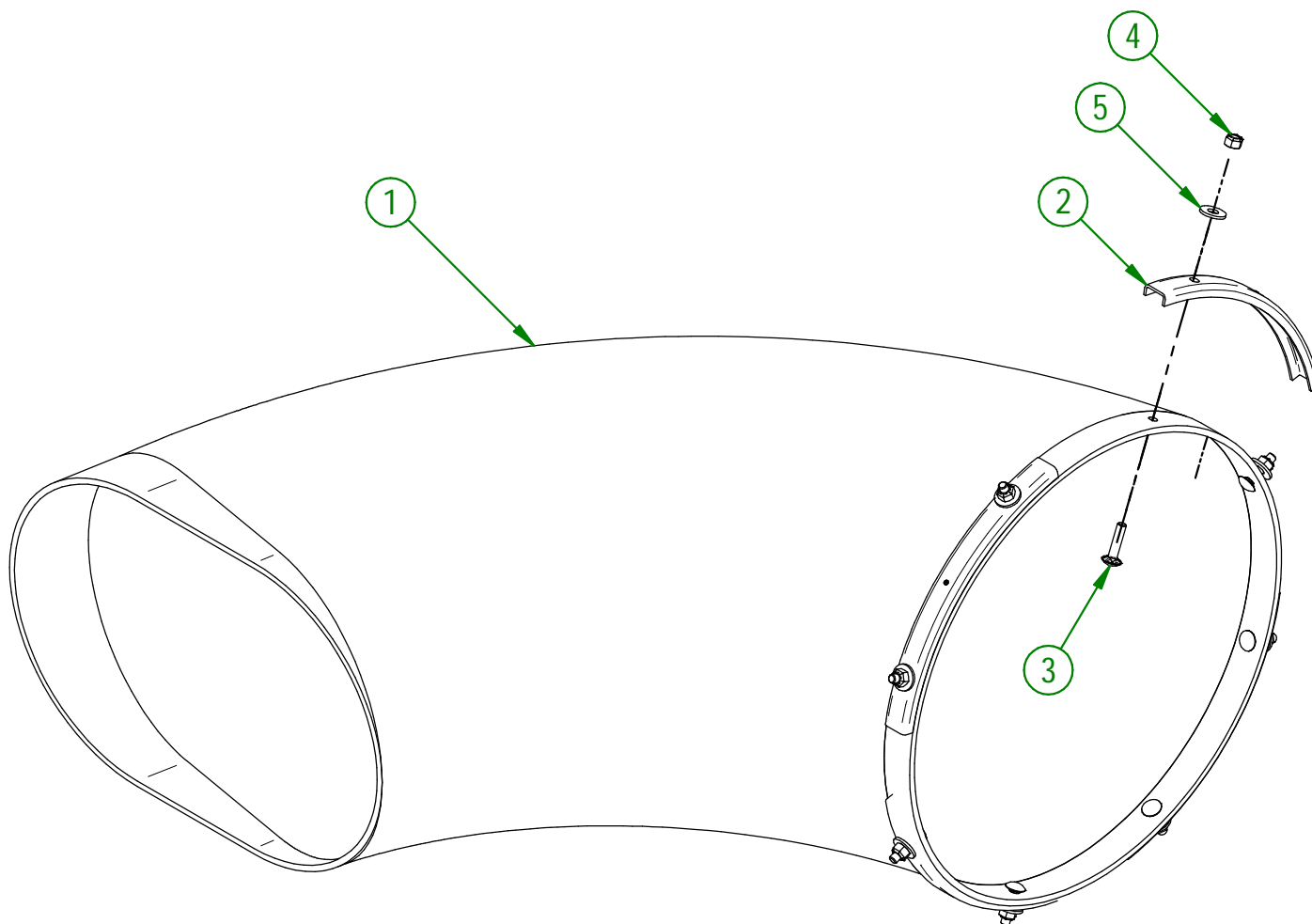

<b>AGRIMETAL</b>	
PLASTIC ELBOW 90° BLACK GROUP	
CREATION : 29/11/24	ASSEMBLY : <b>33-57-3530</b>
REVISION : 16/09/25	AUTHOR : D. CHASSÉ

#	PART #	Qty	TITLE
1	33-50-0560	1	BEARING HOLDER
2	33-09-0000	4	ROLLER BEARING BUSHING
3	33-38-0000	1	FLANGE BEARING UCF 207-20 X Ø 1 1/4" X Ø 1/8 NPT
4	NC01-04-0111	4	CARR. BOLT GR2 ZINC 3/8-16 X 1 1/2"
5	NC02-32-0012	6	LOCK WASHER ZINC 3/8"
6	NC02-07-0018	4	HEX. NUT ZINC 3/8-16
7	40-22-2200	4	SPECIAL WASHER
8	NC02-25-0009	6	WASHER 0.406" I.D. X 0.815 O.D.
9	NC01-25-0112	2	HEX BOLT ZINC 3/8-16 X 3/4"

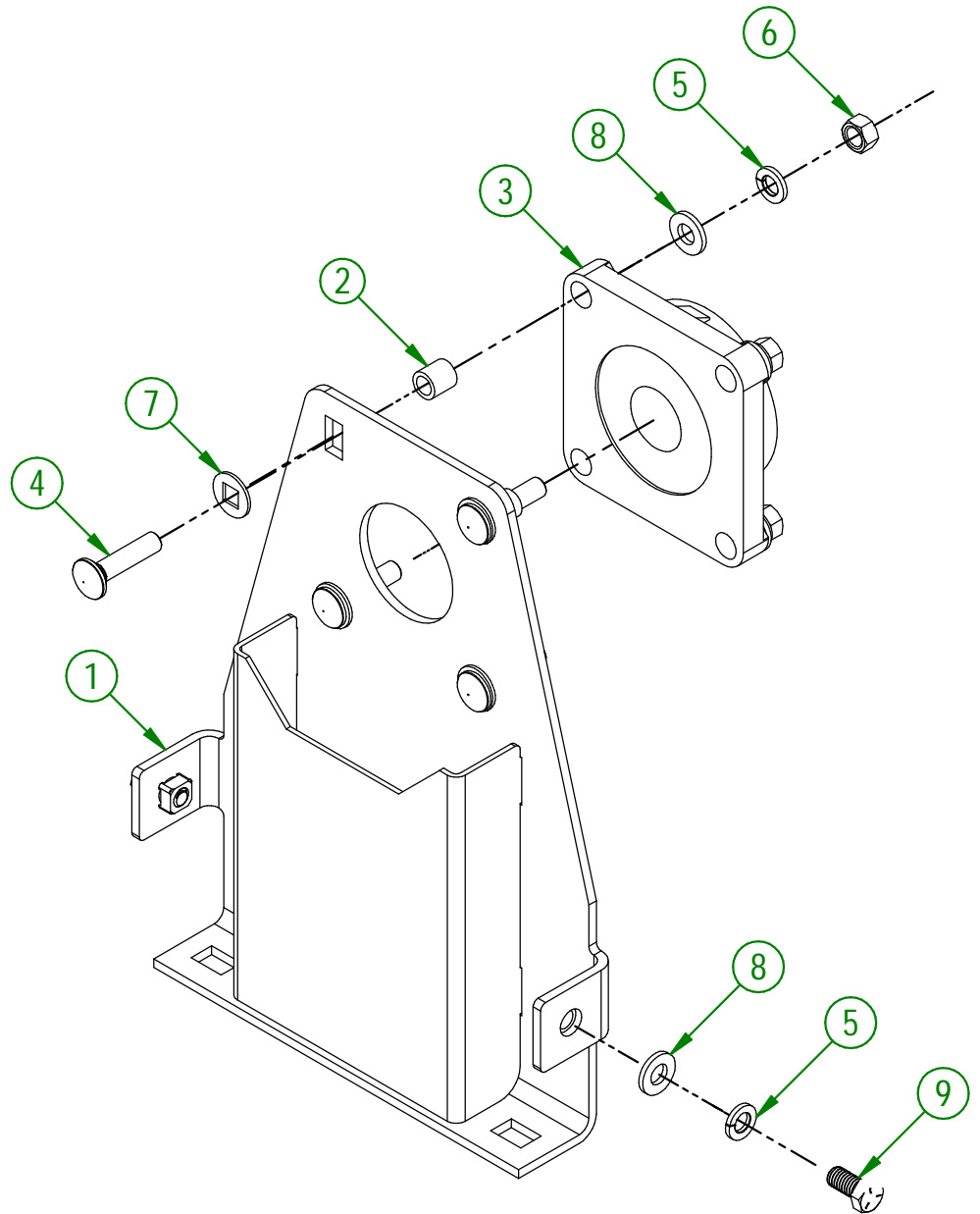

USE THESE PIECES ONLY IF YOUR SERIAL  
NUMBER IS AFFECTED:

#46688 AND BELOW

**AGRIMETAL**  
**BEARING SUPPORT**

CREATION : 06/12/17  
REVISION : 27/11/24

ASSEMBLY : **33-55-0590**  
AUTHOR : J.KABWE

#	# DE PIÈCE	QTÉ	TITRE
1	33-50-0561	1	SUPPORT ROULEMENT A BILLES
2	33-09-0000	4	BAGUE DE ROULEMENT A BILLE
3	33-38-0000	1	ROULEMENT UCF 207-20 X Ø1 1/4" ZEUTRE 1/8 NPTF
4	NC01-04-0111	4	BOULON CARR. GR2 NC ZINC 3/8-16 X 1 1/2"
5	NC02-32-0012	8	RONDELLE RESSORT ZINC 3/8"
6	NC02-07-0018	4	ÉCROU HEX. NC ZINC 3/8-16
7	40-22-2200	4	RONDELLE PLATE SPECIAL
8	NC02-25-0009	8	RONDELLE ACIER .406" D.I. X .815 D.E.
9	NC01-25-0112	4	BOULON HEX. GR5 NC ZINC 3/8-16 X 3/4"

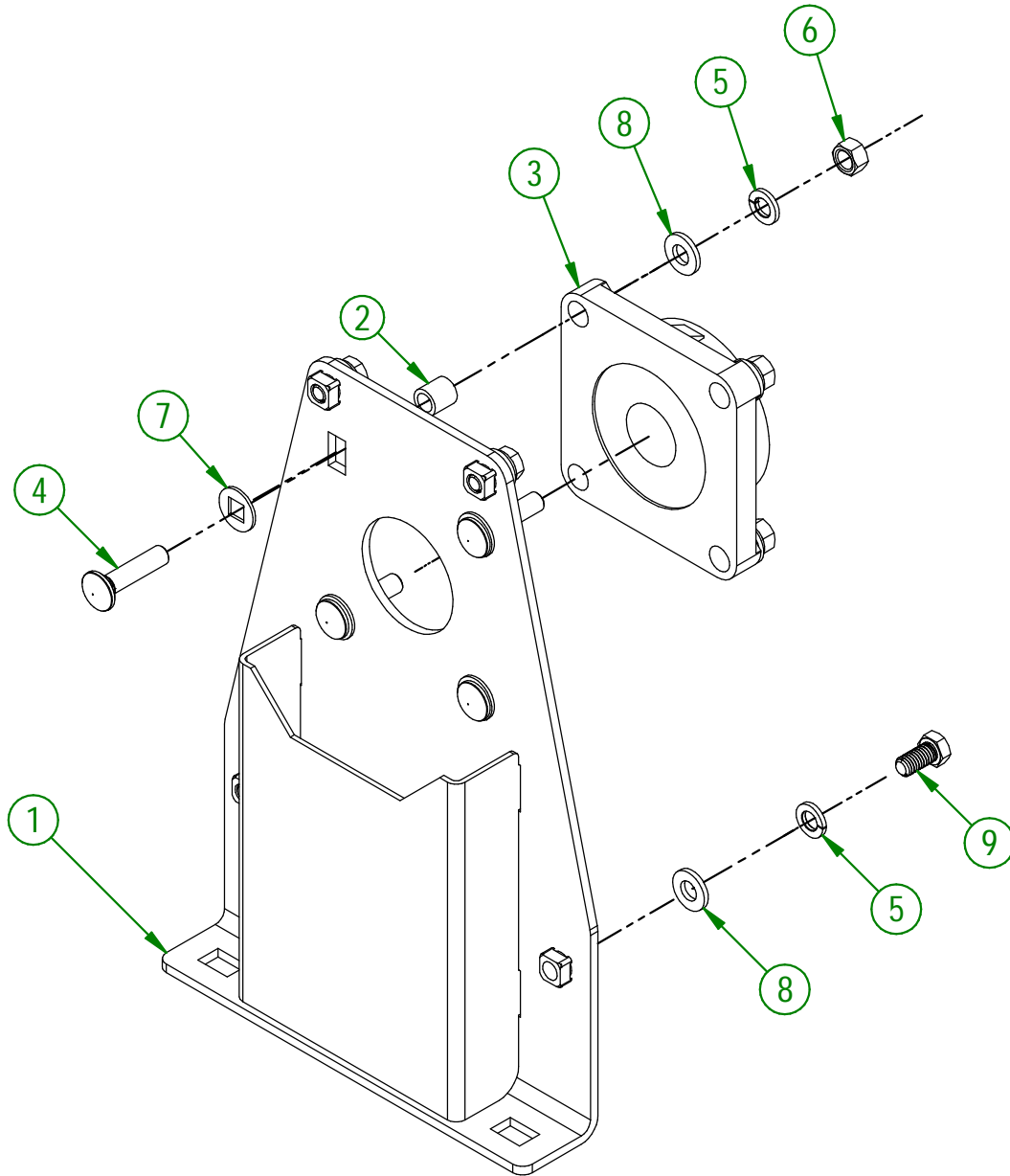

UTILISER CES PIÈCES SEULEMENT SI VOTRE  
NUMÉRO DE SÉRIE EST CONCERNÉ:

#46689 ET PLUS

**AGRIMETAL**

SUPPORT-ROUL. A BILLE UCF 207-20 & HOSE A GRAISSE PRE-ASS (MOD:TB-380 IC)

CREATION : 26/11/24

REVISION : 27/11/24

ASSEMBLY : **33-55-0591**

AUTHOR : J.KABWE

#	PART #	Qty	TITLE
1	NC01-96-0009	2	NYLON-INSERT LOCKNUT ZINC 1/4-20
2	NC01-04-0027	2	CARR. BOLT 1/4-20 X 6" LG
3	NC01-04-0056	2	CARR. BOLT 5/16-18 X3/4"
4	33-01-3015	1	BATTERY STRAPE
5	NC02-32-0011	2	LOCK WASHER ZINC 5/16"
6	NCI3-12-0001	1	12 VOLTS BATTERY
7	NC02-07-0017	2	HEX. NUT 5/16-18
8	NCI3-80-0267	1	RED PROTECTOR FOR BATTERY POST
9	NCI3-80-0268	1	BLACK PROTECTOR FOR BATTERY POST
10	33-01-4000	1	HOUR METER HOLDER
11	NCI3-37-0669	1	HOUR METER

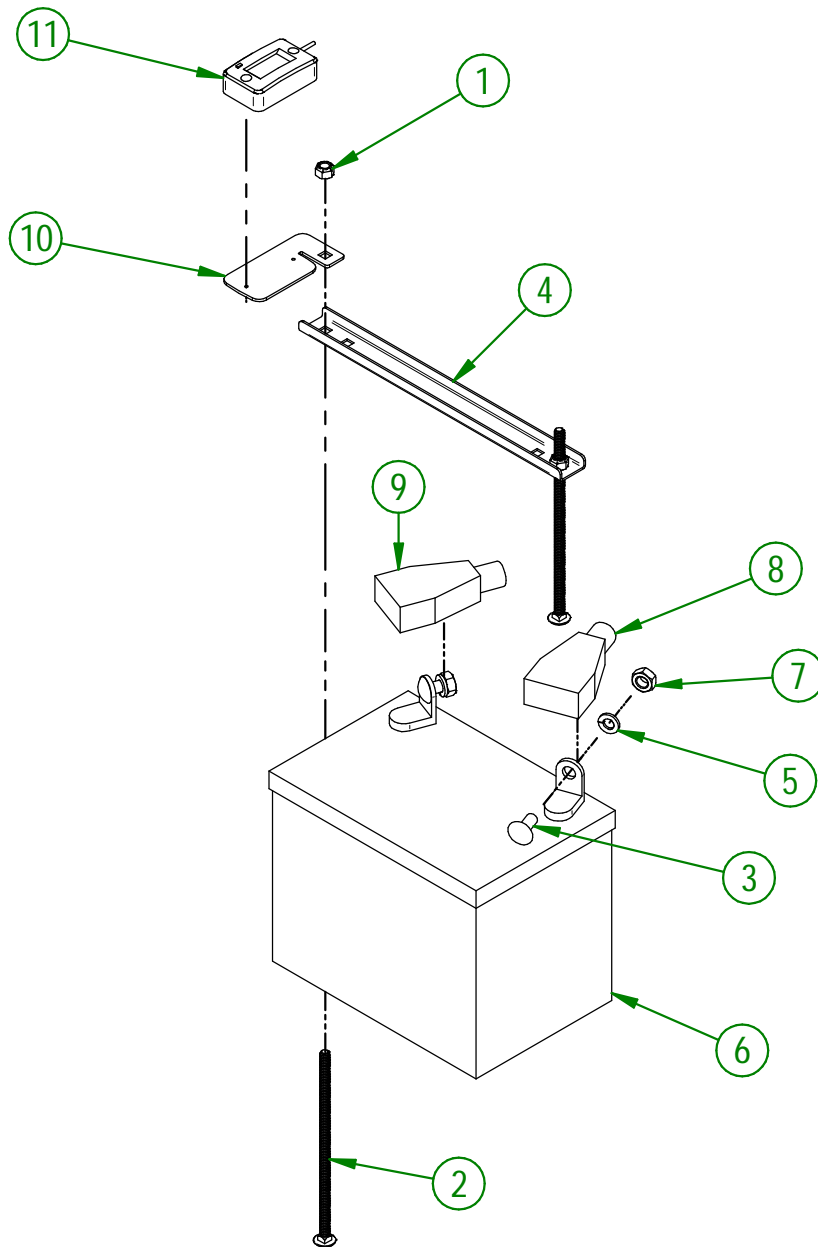

USE THESE PIECES ONLY IF YOUR SERIAL NUMBER IS AFFECTED:

BELOW # 44661

<b>AGRIMETAL</b>	
12 VOLTS BATTERY GROUP.	
CREATION : 31/10/17	ASSEMBLY : <b>33-57-0055</b>
REVISION : 11/09/23	AUTHOR : J.KABWE

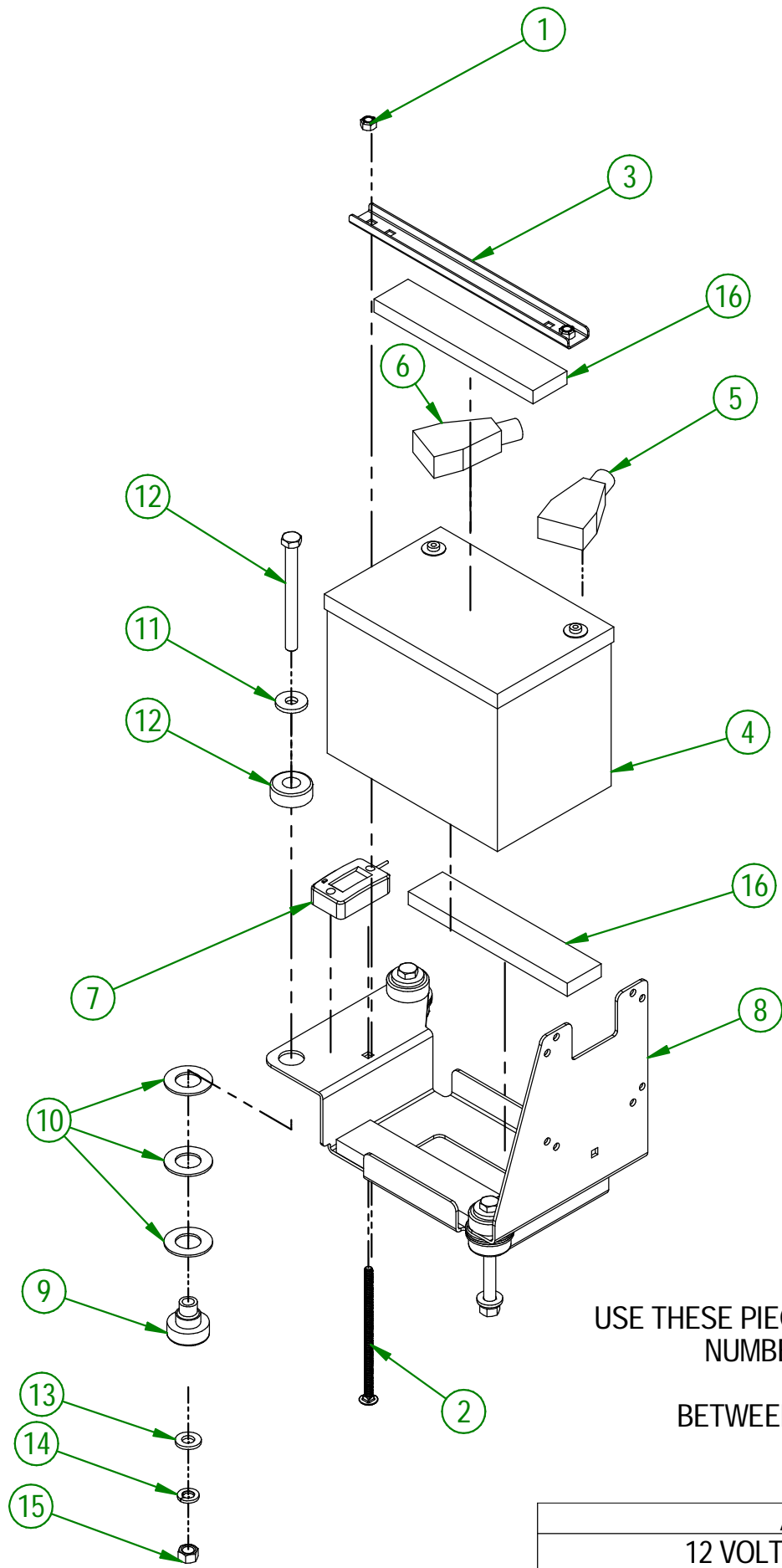

USE THESE PIECES ONLY IF YOUR SERIAL NUMBER IS AFFECTED:

BETWEEN #44661 & #45502

<b>AGRIMETAL</b>	
12 VOLTS BATTERY GROUP.	
CREATION : 29/08/23	ASSEMBLY : <b>33-57-0057</b>
REVISION : 30/05/25	AUTHOR : D. CHASSÉ

33-57-0057

#	PART #	Qty	TITLE
1	NC01-96-0009	2	NYLON-INSERT LOCKNUT ZINC 1/4-20
2	NC01-04-0024	2	CARR. BOLT GR2 ZINC 1/4-20 X 5"
3	33-01-3015	1	BATTERY STRAPE
4	NC13-12-0017	1	12 VOLTS GEL BATTERY
5	NC13-80-0267	1	RED PROTECTOR FOR BATTERY POST
6	NC13-80-0268	1	BLACK PROTECTOR FOR BATTERY POST
7	NC13-37-0669	1	HOUR METER
8	33-57-2400	1	BATTERY SUPPORT PLATE "INCL. STICKER"
9	NC13-15-0354	3	RED RUBBER BASE MOUNT
10	26-03-4800	9	WASHER
11	21-01-0950	3	FLAT WASHER 10GA 1.005" DIA X 25/64"
12	NC01-25-0126	3	HEX. BOLT GR5 ZINC 3/8-16 X 4"
13	NC02-25-0009	3	WASHER 0.406" I.D. X 0.815 O.D.
14	NC02-32-0012	3	LOCK WASHER ZINC 3/8"
15	NC02-07-0018	3	HEX. NUT ZINC 3/8-16
16	33-42-0130	3	BLACK ADHESIVE-BACK STRIP

#	PART #	Qty	TITLE
1	NCI3-12-0017	1	12 VOLTS GEL BATTERY
2	NCI3-80-0267	1	RED PROTECTOR FOR BATTERY POST
3	NCI3-80-0268	1	BLACK PROTECTOR FOR BATTERY POST
4	NCI3-37-0669	1	HOUR METER
5	33-57-2401	1	BATTERY SUPPORT PLATE "INCL. STICKER"
6	NCI3-15-0354	3	RED RUBBER BASE MOUNT
7	26-03-4800	9	WASHER
8	21-01-0950	3	FLAT WASHER 10GA 1.005" DIA X 25/64"
9	NC01-25-0126	3	HEX. BOLT GR5 ZINC 3/8-16 X 4"
10	NC02-25-0009	3	WASHER 0.406" I.D. X 0.815 O.D.
11	NC02-32-0012	3	LOCK WASHER ZINC 3/8"
12	NC02-07-0018	3	HEX. NUT ZINC 3/8-16
13	33-42-0130	2	BLACK ADHESIVE-BACK STRIP
14	NCI3-15-0008	1	RUBBER STRAP
15	33-42-0135	2	BLACK ADHESIVE-BACK STRIP

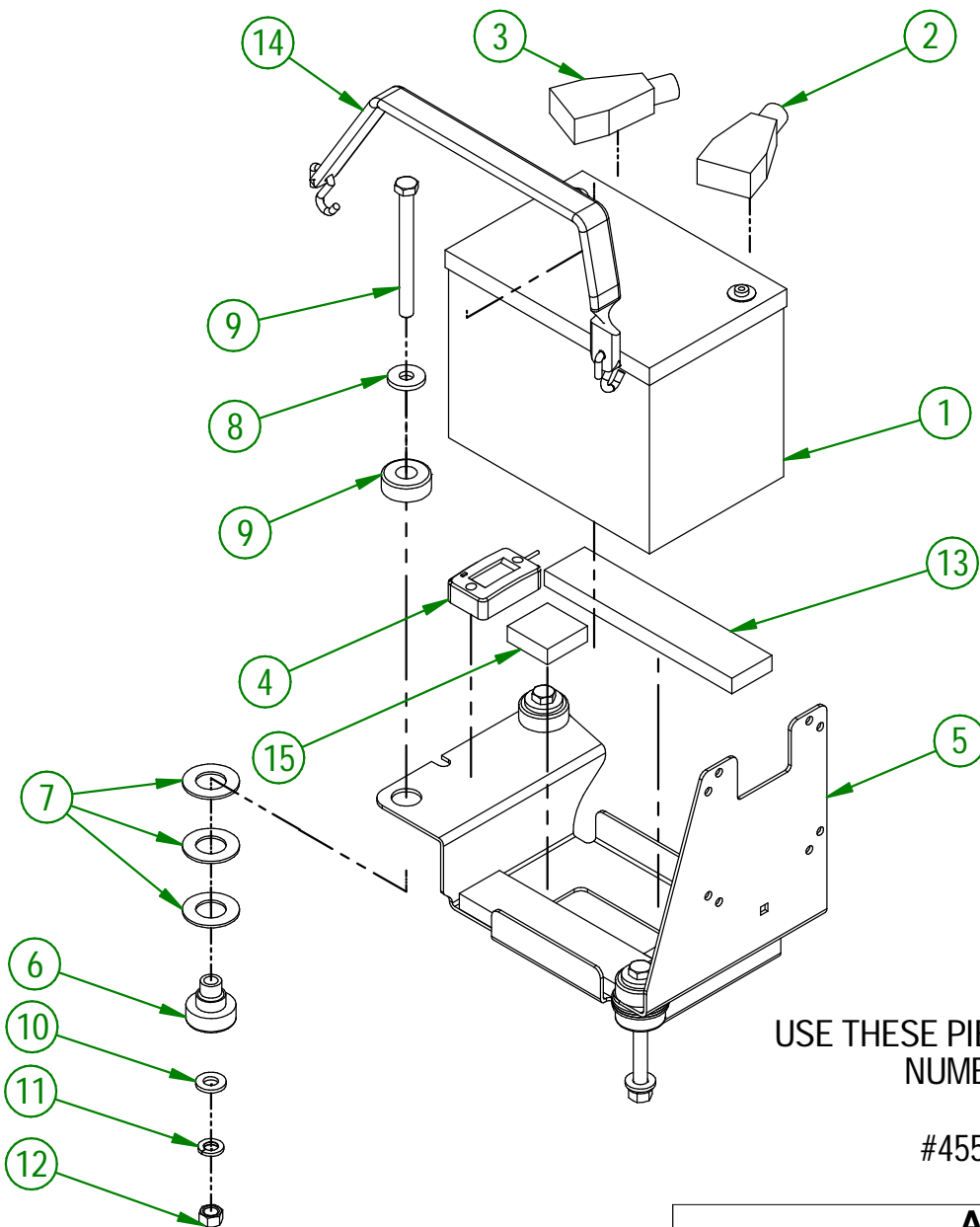

USE THESE PIECES ONLY IF YOUR SERIAL NUMBER IS AFFECTED:

#45503 AND ABOVE

<b>AGRIMETAL</b>	
12 VOLTS BATTERY GROUP.	
CREATION : 21/02/24	ASSEMBLY : <b>33-57-0170</b>
REVISION : 30/05/25	AUTHOR : D. CHASSÉ

#	PART#	QTY	TITLE
1	NC13-30-0237	1	PLASTIC TUBE FOR OPERATOR'S MANUAL
2	NC02-25-0007	3	WASHER ZINC 0.281 = 9/32
3	NC01-17-0004	3	HEX. BOLT GR2 ZINC 1/4-20 X 3/4"
4	36-01-2430	3	FLAT WASHER 14GA X 17/64" ID. X 13/16" O.D.
5	NC01-96-0009	3	NYLON-INSERT LOCKNUT ZINC 1/4-20
6	33-98-0635	1	OPERATOR MANUAL TB 350 IC

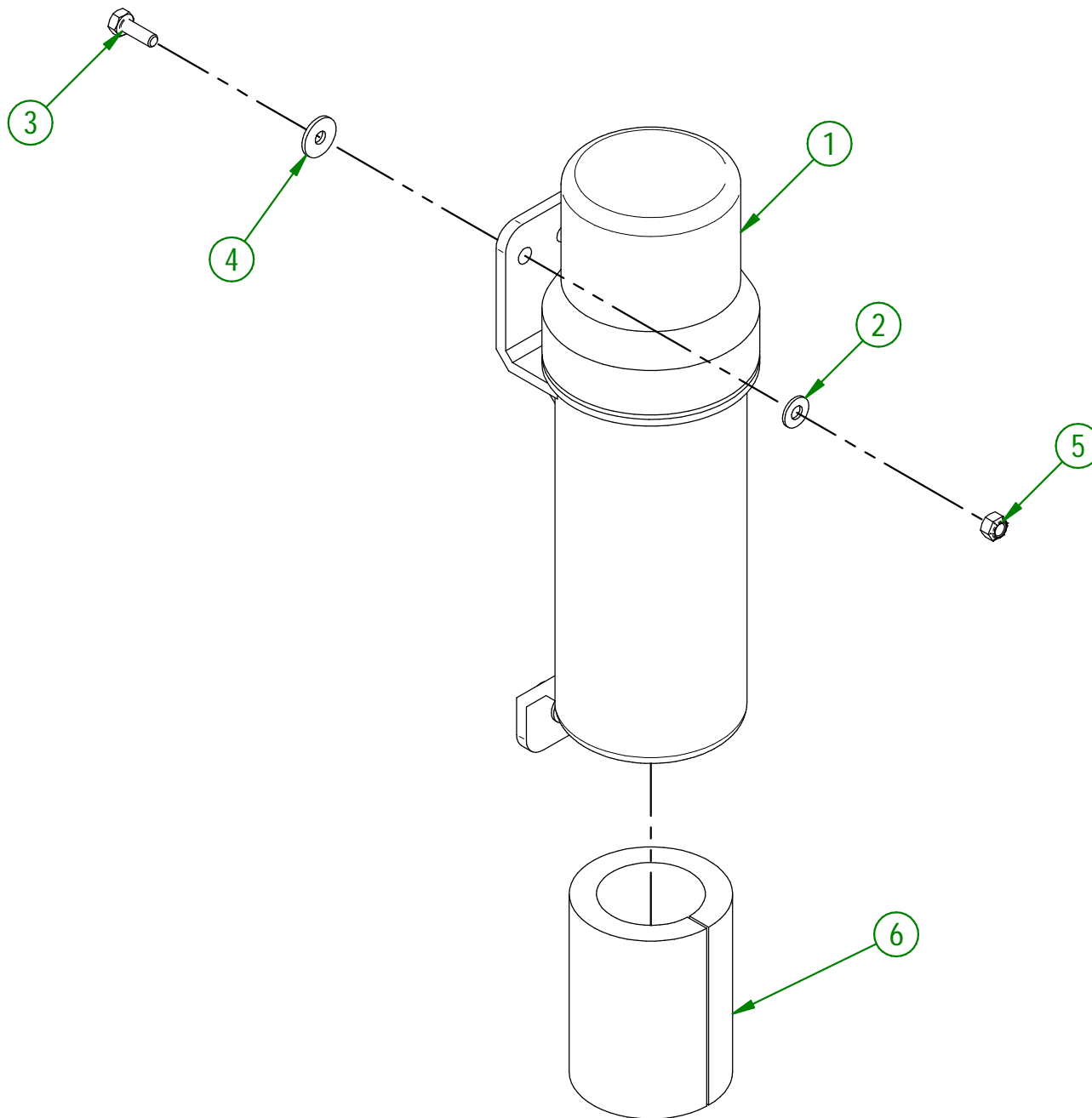

<b>AGRIMETAL</b>	
ASSEMBLY OPERATOR MANUEL TUBE	
CREATION : 29/11/24	ASSEMBLY : <b>33-57-0566</b>
REVISION : 29/11/24	AUTHOR : D. CHASSÉ

33-57-3505

#	PART #	Qty	TITLE
1	33-50-0005	4	FRAME SUPPORT
2	33-04-0130	1	SUPPORT REINFORCING
3	33-01-7620	2	SUPPORT REINFORCING
4	NC01-17-0121	24	HEX. BOLT GR2 ZINC 3/8-16 X 2 1/2"
5	NC01-17-0113	16	HEX. BOLT GR2 ZINC 3/8-16 X 7/8"
6	NC02-14-0019	32	FLANGE NUT HEX. NC 3/8-16 GR. B
7	01-01-2485	12	FLAT WASHER
8	NC02-32-0012	12	LOCK WASHER ZINC 3/8"
9	NC02-07-0018	12	HEX. NUT ZINC 3/8-16
10	NC01-17-0114	4	HEX. BOLT GR2 ZINC 3/8-16 X 1"

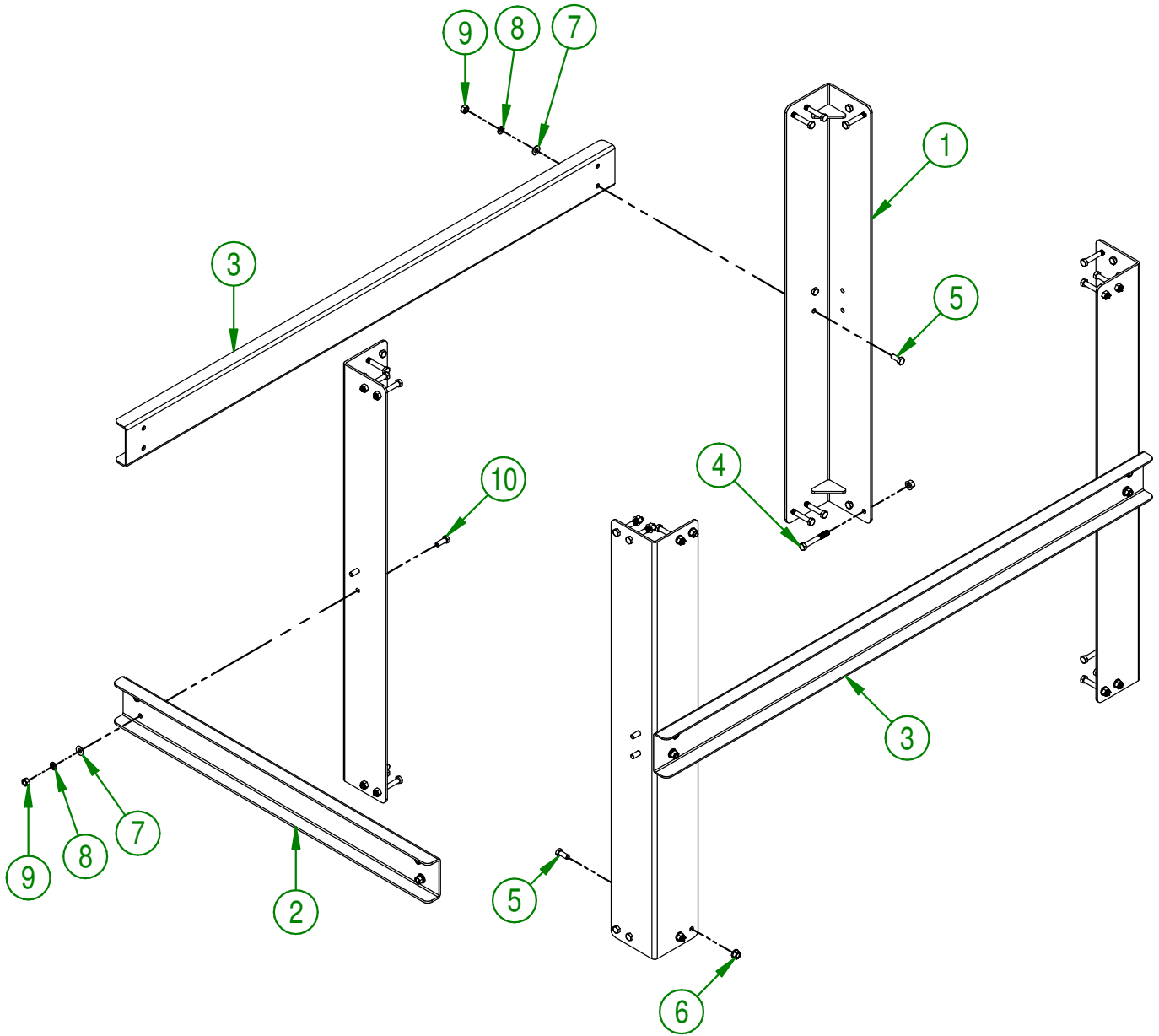

<b>AGRIMETAL</b>	
<b>FRAME SUPPORT GROUP.</b>	
CREATION : 28/11/17	ASSEMBLY : <b>33-57-3505</b>
REVISION : 08/01/18	AUTHOR : J.KABWE

#	PART#	QTY	TITRE
1	NCI3-33-0227	1	STICKER FUSE 15 AMP MAXIMUM
2	NCI3-33-0266	1	STICKER IMPORT 6" 152 MM
3	NCI3-33-0192	6	STICKER (PROJECTION RISK)
4	NCI3-33-0185	6	STICKER PICTOGRAM (FIRE + CIGARETTE)
5	NCI3-33-2702	6	STICKER AGRIMETAL
6	NCI3-33-0183	3	STICKER CAUTION OPERATION MANUAL
7	NCI3-33-0342	3	STICKER 99 DB
8	NCI3-33-0024	1	STICKER GREASE HERE
9	NCI3-33-0178	1	STICKER IMPORTANT PLEASE CHECK OIL LEVEL...
10	NCI3-33-2674	2	STICKER TO PROGRAM REMOTE CONTROL

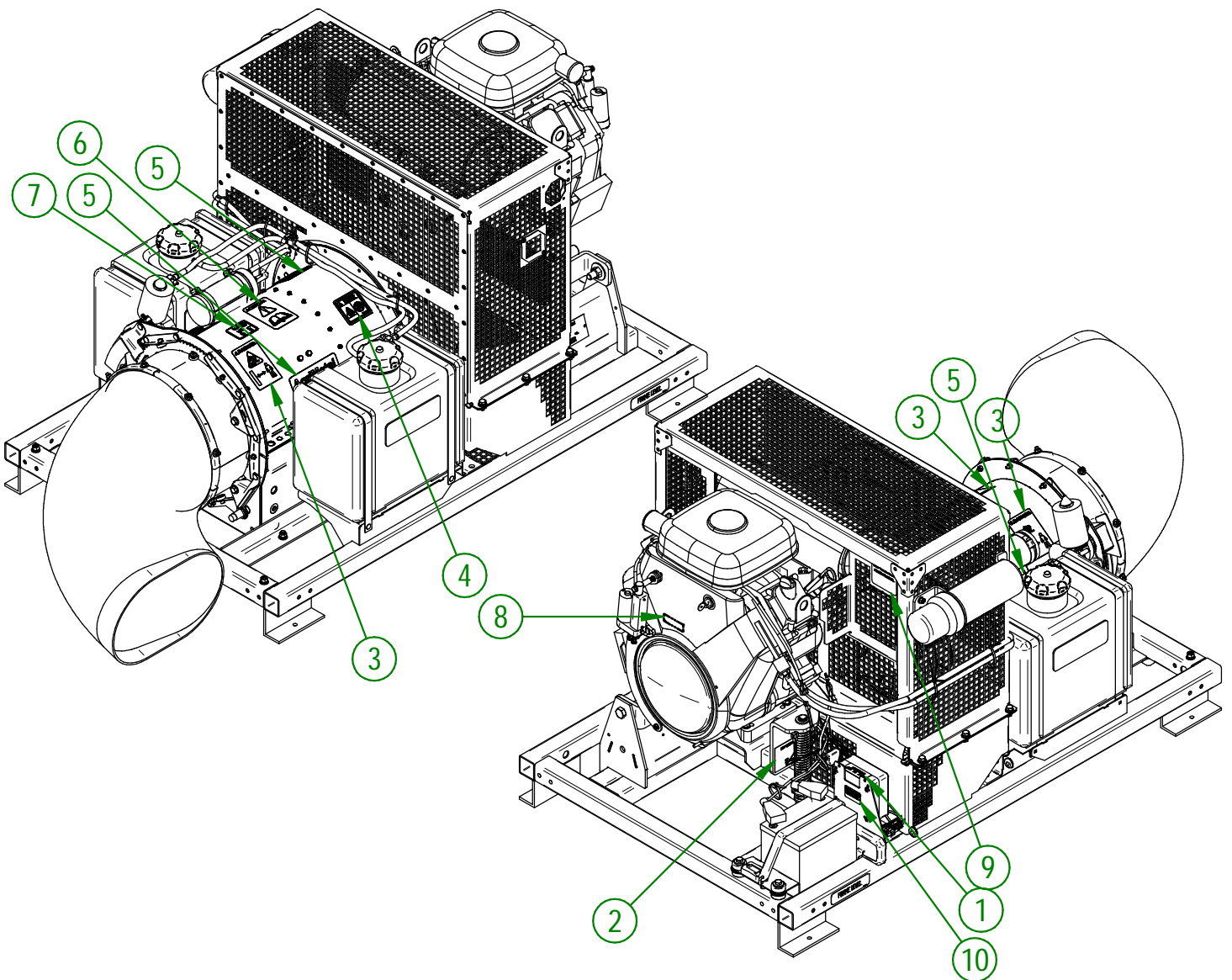
**AGRIMETAL****TURBINE BLOWER 350 IC CARB**

CREATION : 31/10/22  
 REVISION : 08/01/26

ASSEMBLY : **33-99-3605**  
 AUTHOR : D. CHASSÉ