

AgriMetal

PARTS LIST

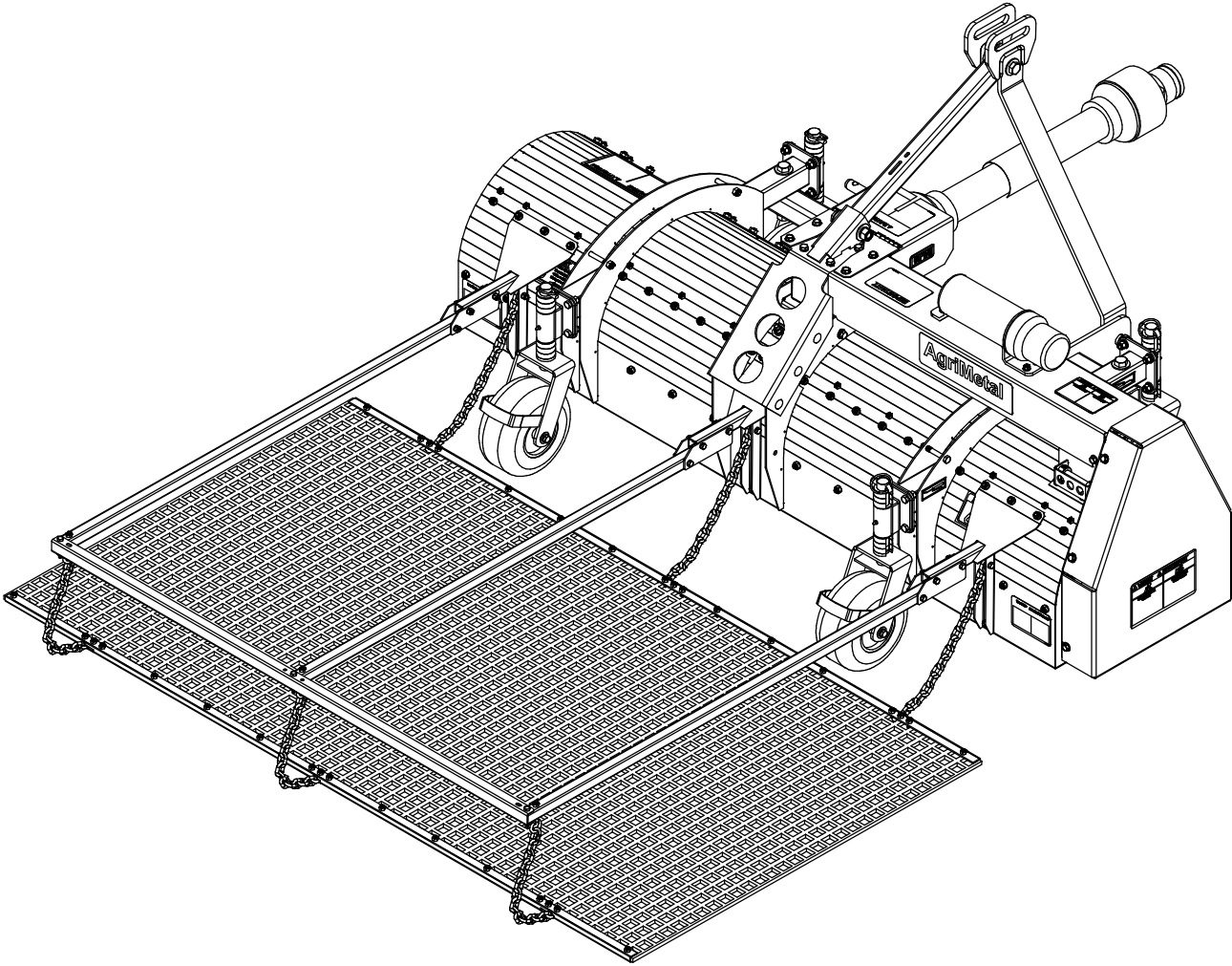

CORE BREAKER 690-TP-B

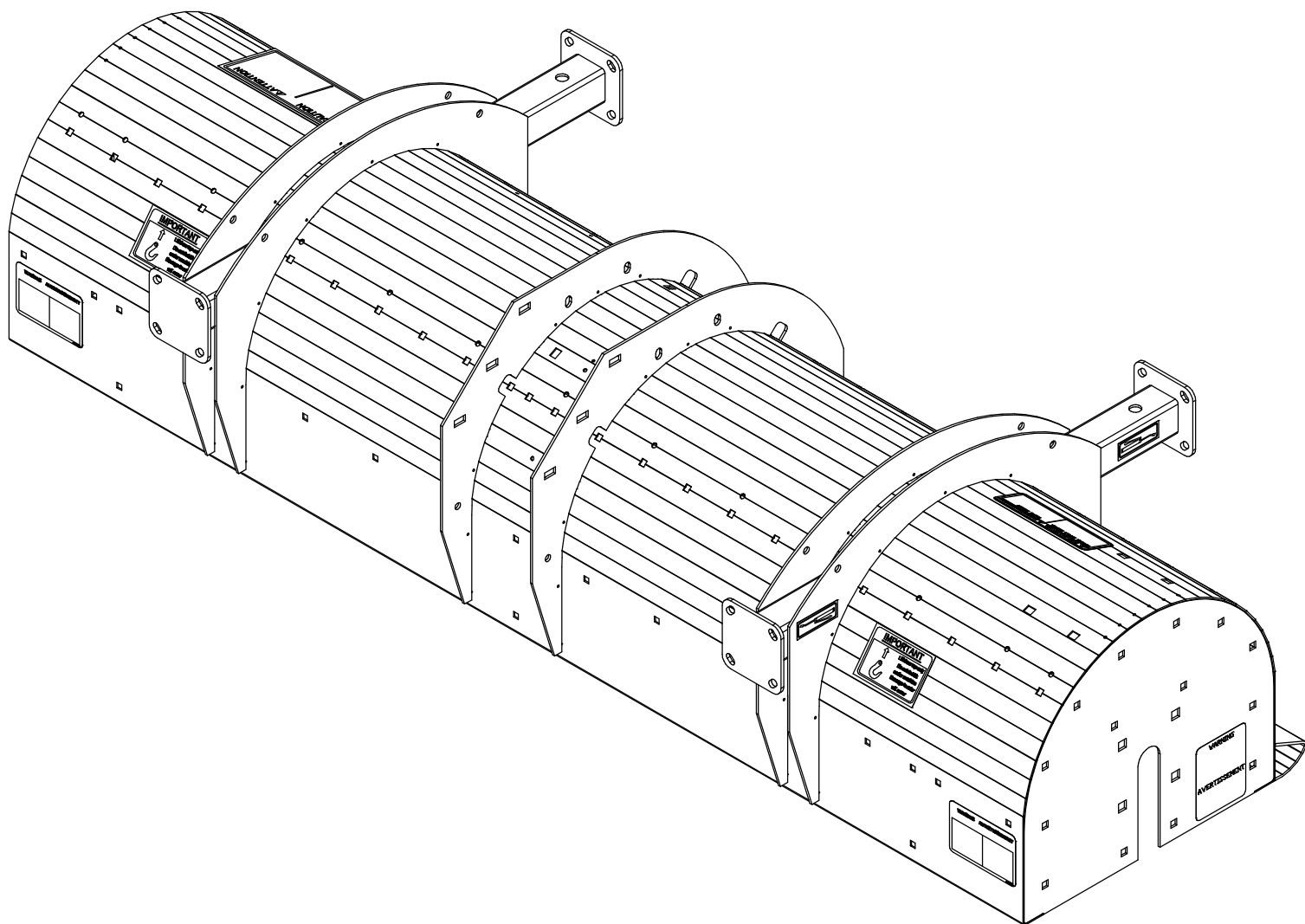

AGRIMETAL	
FRAME "STICKER INCLUDED" (MOD.690)	
CREATION : 24/04/25	ASSEMBLY : 50-55-1040
REVISION : 24/04/25	AUTHOR : N. GOULET

50-57-1001

#	PART #	Qty	TITLE
1	50-50-0060	1	TRANSMISSION BASE
2	50-55-1003	1	90° ANGLE GEAR BOX SHAFTING 2 (MOD.690)
3	NC01-07-0109	4	CARR. BOLT GR2 ZINC 3/8-16 X 1"
4	NC01-25-0113	4	HEX. BOLT GR5 ZINC 3/8-16 X 7/8"
5	NC01-25-0114	4	HEX. BOLT GR2 ZINC 3/8-16 X 1"
6	NC02-07-0018	4	HEX. NUT ZINC 3/8-16
7	NC02-25-0009	8	WASHER 0.406" I.D. X 0.815 O.D.
8	NC02-32-0012	12	LOCK WASHER ZINC 3/8"

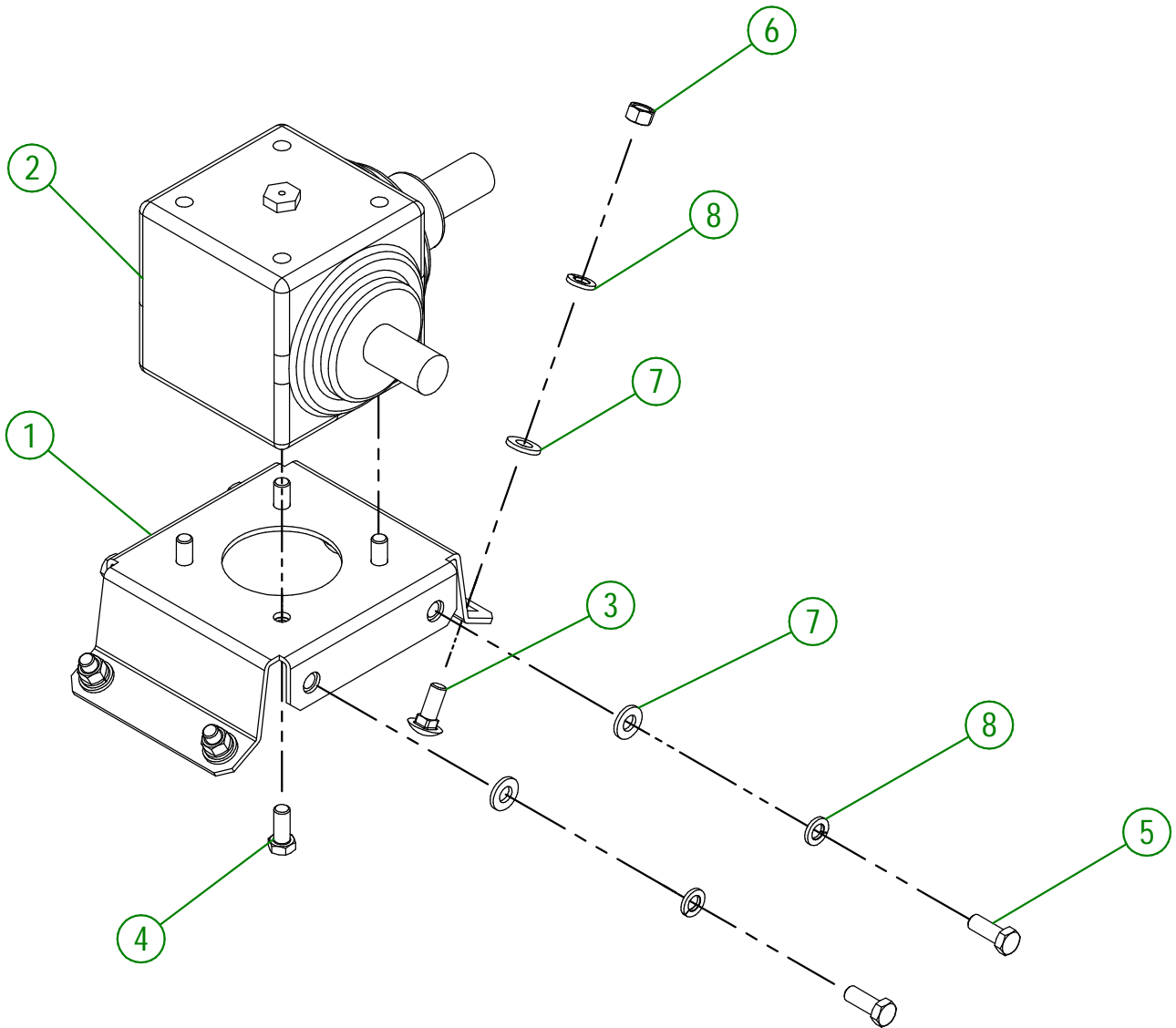

AGRIMETAL	
TRANSMISSION BASE GROUP	
CREATION : 22/04/25	ASSEMBLY : 50-57-1001
REVISION : 22/04/25	AUTHOR : N. GOULET

#	PART #	Qty	TITLE
1	50-50-0045	1	BEARING SUPPORT
2	NC01-07-0107	4	CARR. BOLT GR2 ZINC 3/8-16 X 3/4"
3	NC02-07-0018	4	HEX. NUT ZINC 3/8-16
4	NC02-32-0012	4	LOCK WASHER ZINC 3/8"

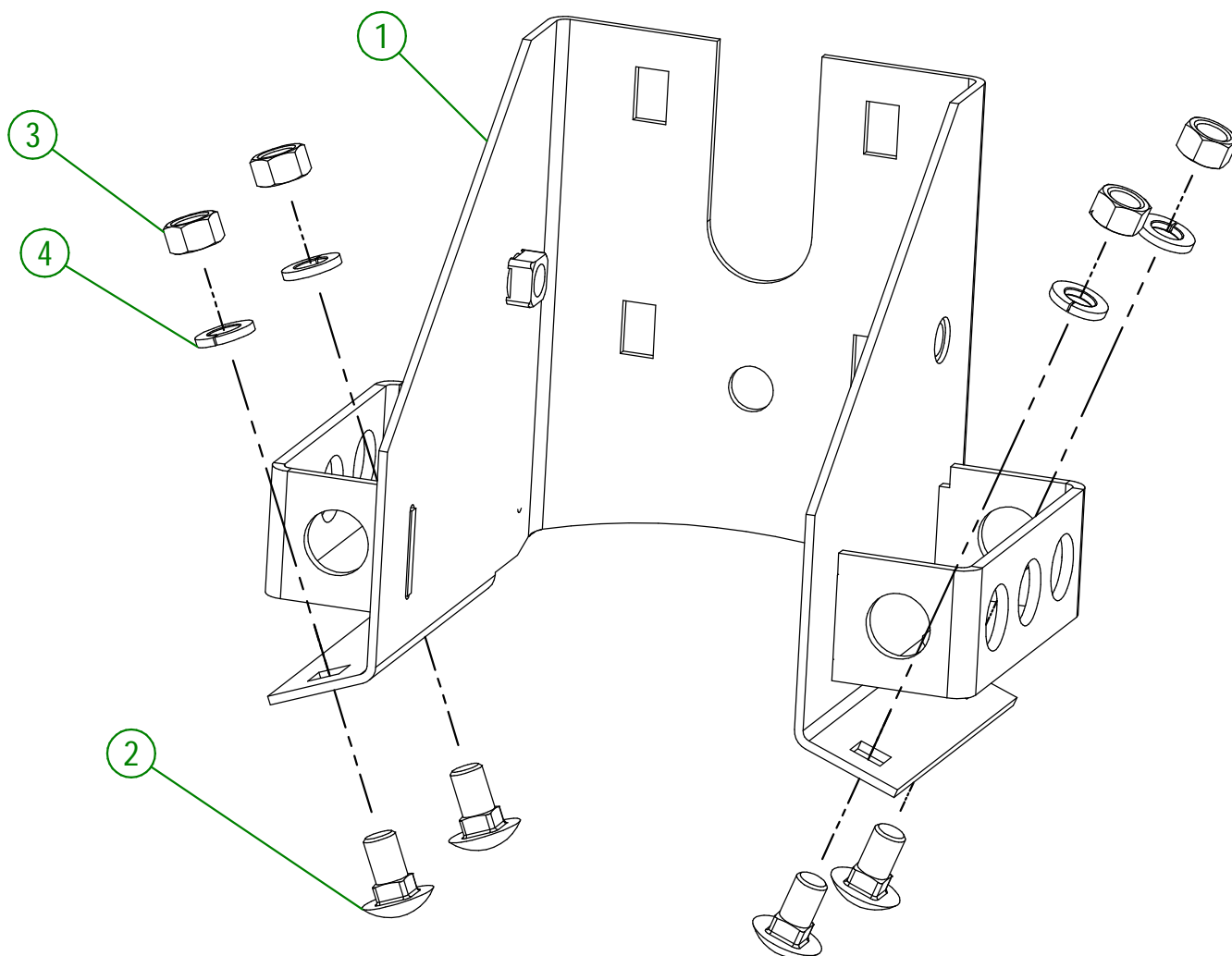
**AGRIMETAL****BEARING SUPPORT GROUP.**CREATION : 23/04/25
REVISION : 23/04/25ASSEMBLY : **50-57-0007**
AUTHOR : N. GOULET

50-57-0010

#	PART #	Qty	TITLE
1	50-50-0040	1	BEARING SUPPORT
2	NC01-07-0107	11	CARR. BOLT GR2 ZINC 3/8-16 X 3/4"
3	NC01-07-0110	1	CARR. BOLT GR5 ZINC 3/8-16 X 1 1/4"
4	NC02-07-0018	12	HEX. NUT ZINC 3/8-16
5	NC02-32-0012	12	LOCK WASHER ZINC 3/8"

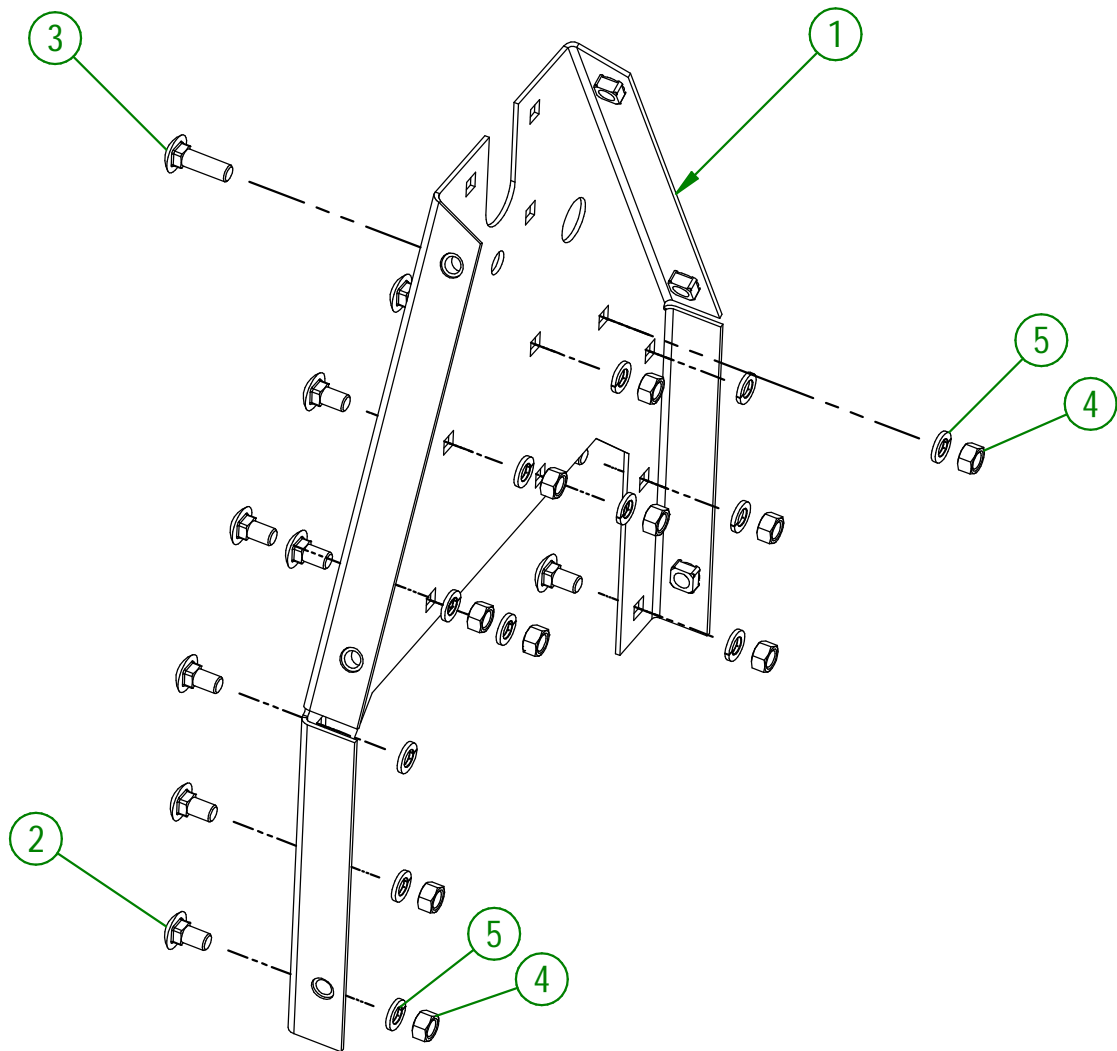

AGRIMETAL	
BEARING SUPPORT GROUP	
CREATION : 23/04/25	ASSEMBLY : 50-57-0010
REVISION : 23/04/25	AUTHOR : N. GOULET

50-57-1015

#	PART #	Qty	TITLE
1	50-01-0935	2	COUNTER KNIF STOPPER (MOD.690)
2	NC01-07-0002	26	CARR. BOLT GR5 ZINC 1/4-20 X 5/8"
3	NC01-96-0009	26	NYLON-INSERT LOCKNUT ZINC 1/4-20

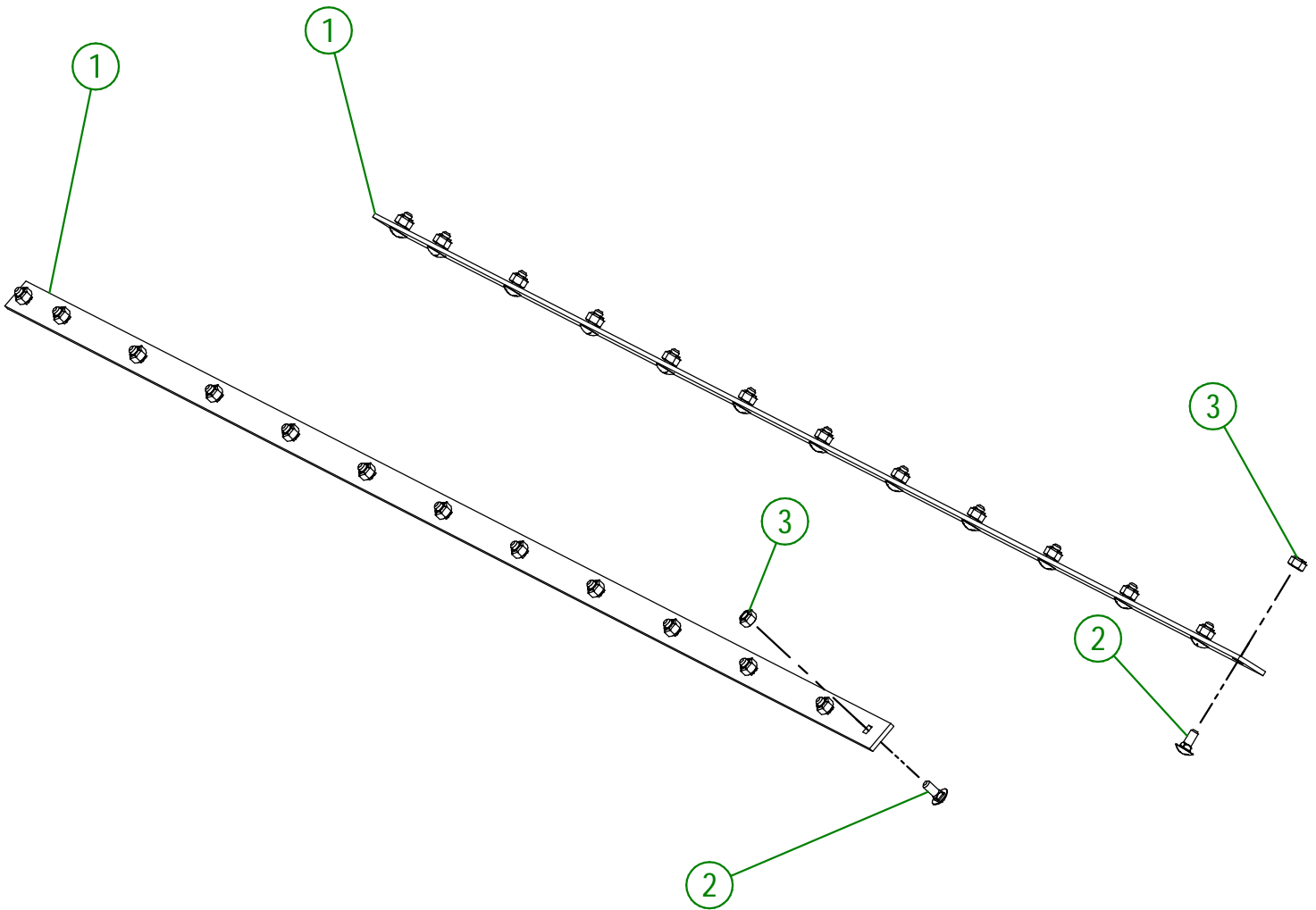

AGRIMETAL	
COUNTER KNIF STOPPER GROUP (MOD.690)	
CREATION : 22/04/25	ASSEMBLY : 50-57-1015
REVISION : 22/04/25	AUTHOR : N. GOULET

50-57-1020

#	PART #	Qty	TITLE
1	50-01-0915	46	COUNTER KNIF
2	NC01-07-0055	28	CARR. BOLT GR5 NC ZINC 5/16-18 X 5/8"
3	NC01-07-0056	18	CARR. BOLT GR5 NC ZINC 5/16-18 X 3/4"
4	NC02-07-0017	46	HEX. NUT 5/16-18
5	NC02-32-0011	46	LOCK WASHER ZINC 5/16"

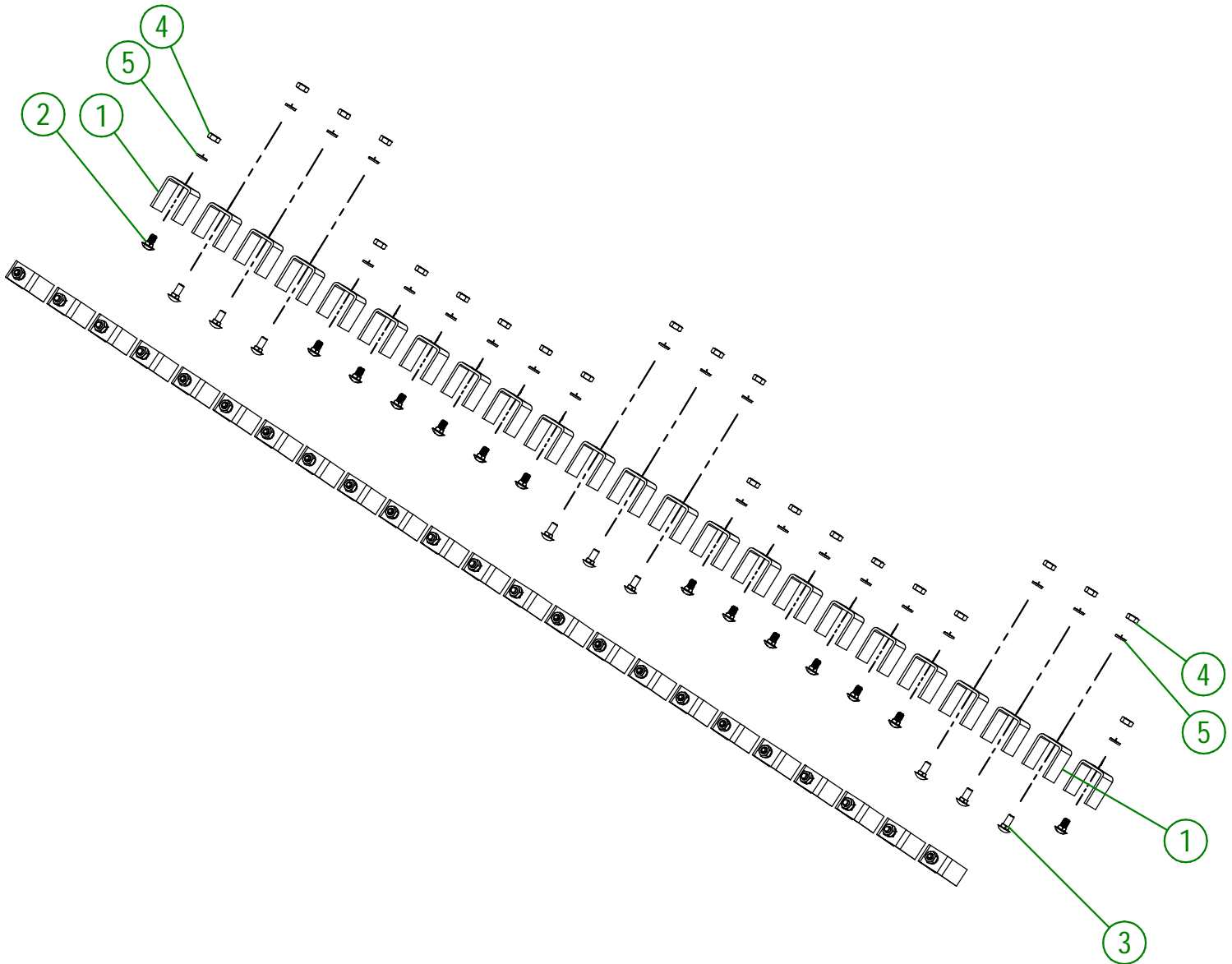

AGRIMETAL	
COUNTER KNIF GROUP	
CREATION : 22/04/25	ASSEMBLY : 50-57-1020
REVISION : 23/04/25	AUTHOR : N. GOULET

50-57-1025

#	PART #	Qty	TITLE
1	50-01-1510	6	HINGE
2	50-01-2485	1	BACK DEFLECTOR (MOD.690)
3	50-50-0025	2	DRAG MATT SUPPORT ONLY
4	50-50-1025	1	DRAG MATT CENTRAL SUPPORT ONLY
5	NC01-07-0055	16	CARR. BOLT GR5 NC ZINC 5/16-18 X 5/8"
6	NC01-07-0056	3	CARR. BOLT GR5 NC ZINC 5/16-18 X 3/4"
7	NC01-37-0009	9	HEX. BOLT GR8 NF ZINC 1/4-28 X 1 3/4"
8	NC01-37-0010	3	HEX. BOLT GR8 NF ZINC 1/4-28 X 2"
9	NC01-97-0004	12	NYLON-INSERT LOCKNUT ZINC 1/4-28
10	NC02-07-0017	19	HEX. NUT 5/16-18
11	NC02-26-0001	24	PLAIN WASHER STEEL ZINC ,062 X ,515" OD X ,264" ID
12	NC02-32-0011	19	LOCK WASHER ZINC 5/16"

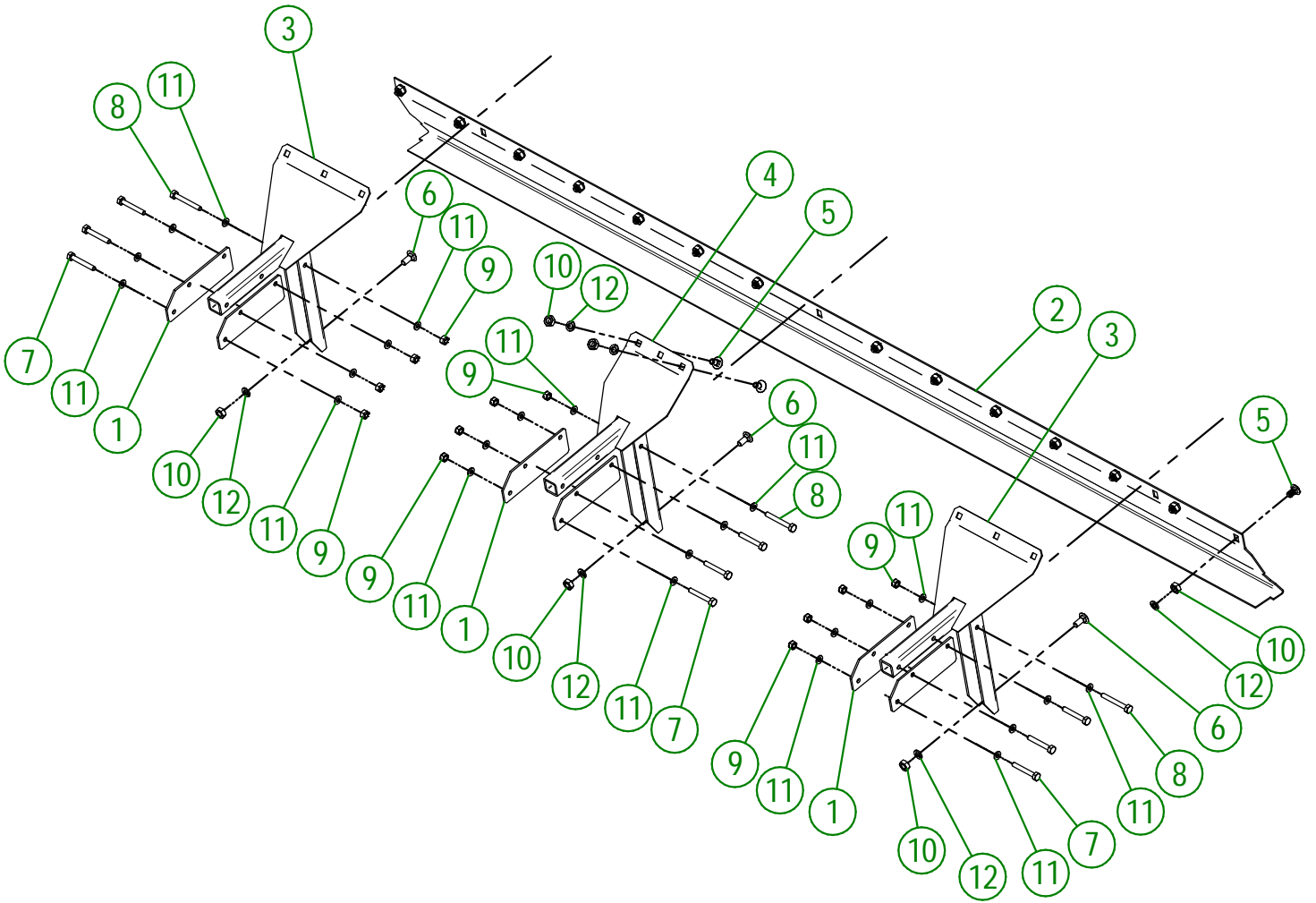

AGRIMETAL	
BACK DEFLECTOR & DRAG MATT SUPPORT ASSY GROUP	
CREATION : 23/04/25	ASSEMBLY : 50-57-1025
REVISION : 23/04/25	AUTHOR : N. GOULET

50-57-1030

#	PART #	Qty	TITLE
1	01-41-0910	1	KEY
2	12-38-0001	2	FLANGE BEARING UCF 207-20
3	50-01-0920	2	BEARING PROTECTOR
4	50-01-2400	6	RUBBER FINGER CHANNEL (I9 3/8"LG)
5	50-01-2440	24	RUBBER FINGER CHANNEL (II 7/8"LG)
6	50-39-0150	1	PULLEY 2MA60 X Ø I 1/4" KW 1/4" 2SS 5/16"-18
7	50-45-0400	27	RUBBER FINGER
8	50-50-1005	1	ROTOR ONLY (MOD.690)
9	NC01-07-0060	144	CARR. BOLT GR2 5/16-18 X I 1/2
10	NC01-07-0107	4	CARR. BOLT GR2 ZINC 3/8-16 X 3/4"
11	NC01-07-0235	8	CARR. BOLT ZINC GR5 1/2-13 X I 1/2"
12	NC01-96-0010	144	NYLON NUT HEX. ZINC 5/16-18
13	NC02-07-0018	4	HEX. NUT ZINC 3/8-16
14	NC02-07-0020	8	HEX. NUT ZINC 1/2-13
15	NC02-32-0012	4	LOCK WASHER ZINC 3/8"
16	NC02-32-0014	8	LOCK WASHER ZINC 1/2"
17	NC02-44-0102	4	SOCKET HEAD CAP SCREW 5/16-18 X 5/16"
18	NC02-44-0103	2	SET SCREW 5/16-18 X 3/8"
19	NC14-25-1520	2	V BELT 1/2"

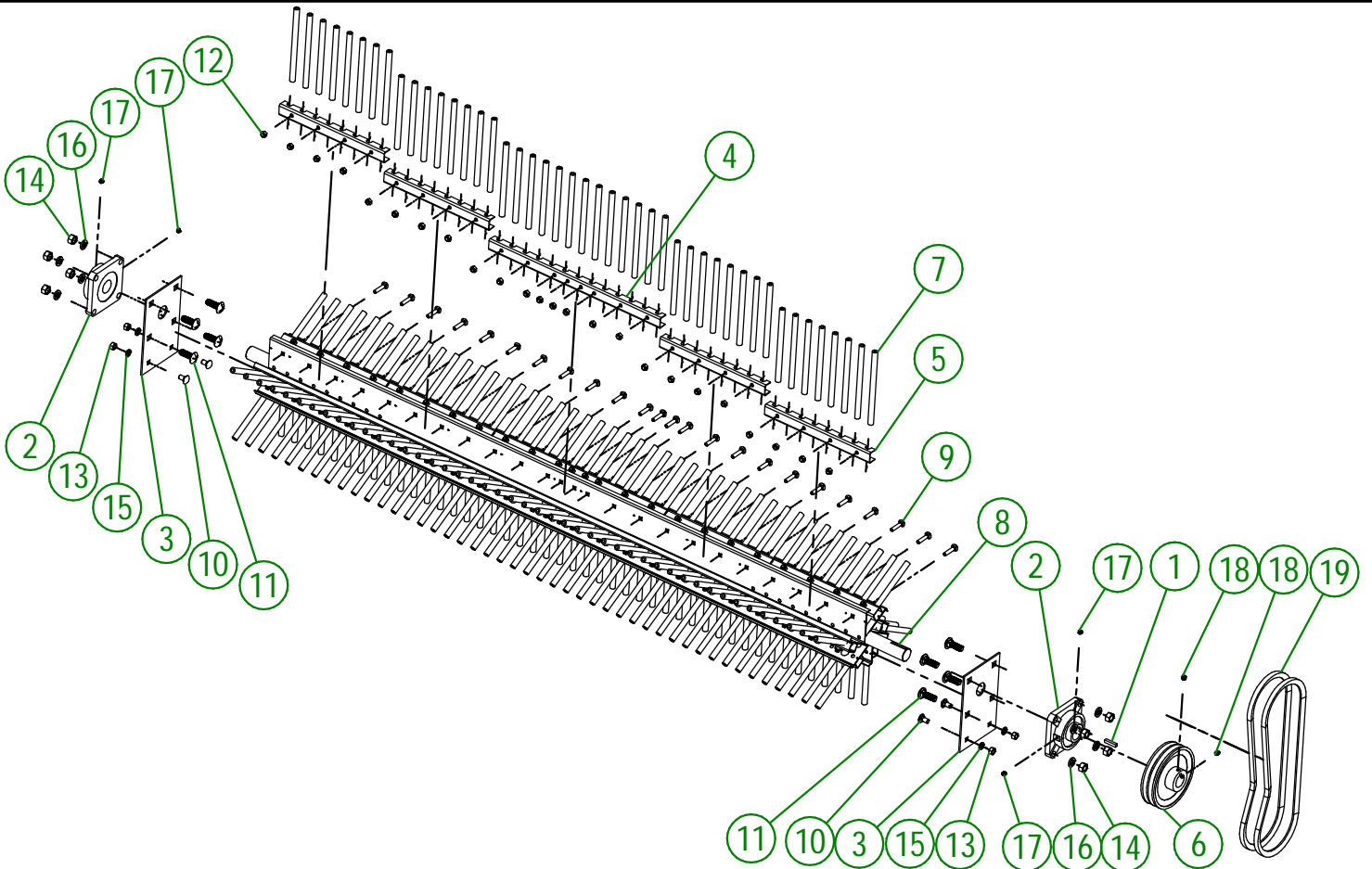

AGRIMETAL	
ROTOR ASSY GROUP (MOD.690)	
CREATION : 23/04/25	ASSEMBLY : 50-57-1030
REVISION : 23/04/25	AUTHOR : N. GOULET

50-57-1045

#	PART #	Qty	TITLE
1	16-01-2720	24	WASHER 13/16" DIA. X 13/64"
2	50-01-2480	1	RUBBER SUPPORT ONLY (MOD.690)
3	50-42-0035	1	RUBBER PAD HARDWARE INCLUDED (MOD.690)
4	NC01-07-0055	15	CARR. BOLT GR5 NC ZINC 5/16-18 X 5/8"
5	NC01-78-0016	24	ALUMINIUM BLIND POP RIVET STEEL MANDREL 0.187 X 0.690
6	NC02-07-0017	15	HEX. NUT 5/16-18
7	NC02-32-0011	15	LOCK WASHER ZINC 5/16"

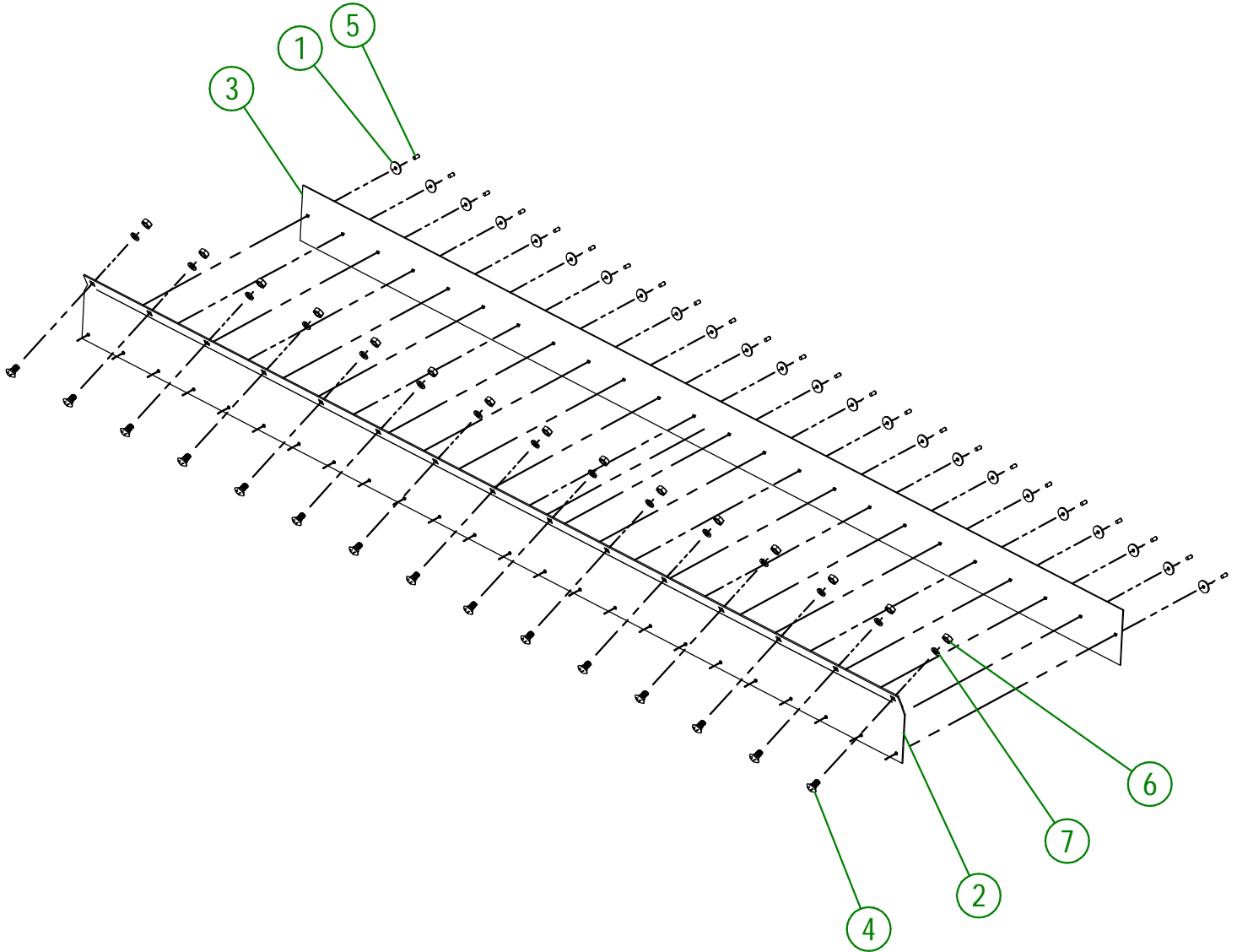

AGRIMETAL	
RUBBER SUPPORT ASSY (MOD.690)	
CREATION : 23/04/25	ASSEMBLY : 50-57-1045
REVISION : 23/04/25	AUTHOR : N. GOULET

#	PART #	Qty	TITLE
1	22-50-0035	1	SWIVEL WHEEL SUPPORT ONLY
2	NC01-25-0114	4	HEX. BOLT GR2 ZINC 3/8-16 X 1"
3	NC01-69-0785	1	STRAIGHT GREASE FITTING 1/4-28
4	NC02-07-0018	4	HEX. NUT ZINC 3/8-16
5	NC02-25-0009	4	WASHER 0.406" I.D. X 0.815 O.D.
6	NC02-32-0012	4	LOCK WASHER ZINC 3/8"
7	NC13-15-0049	2	O-RING WASHER 1/8" X 1" X 1 1/4"

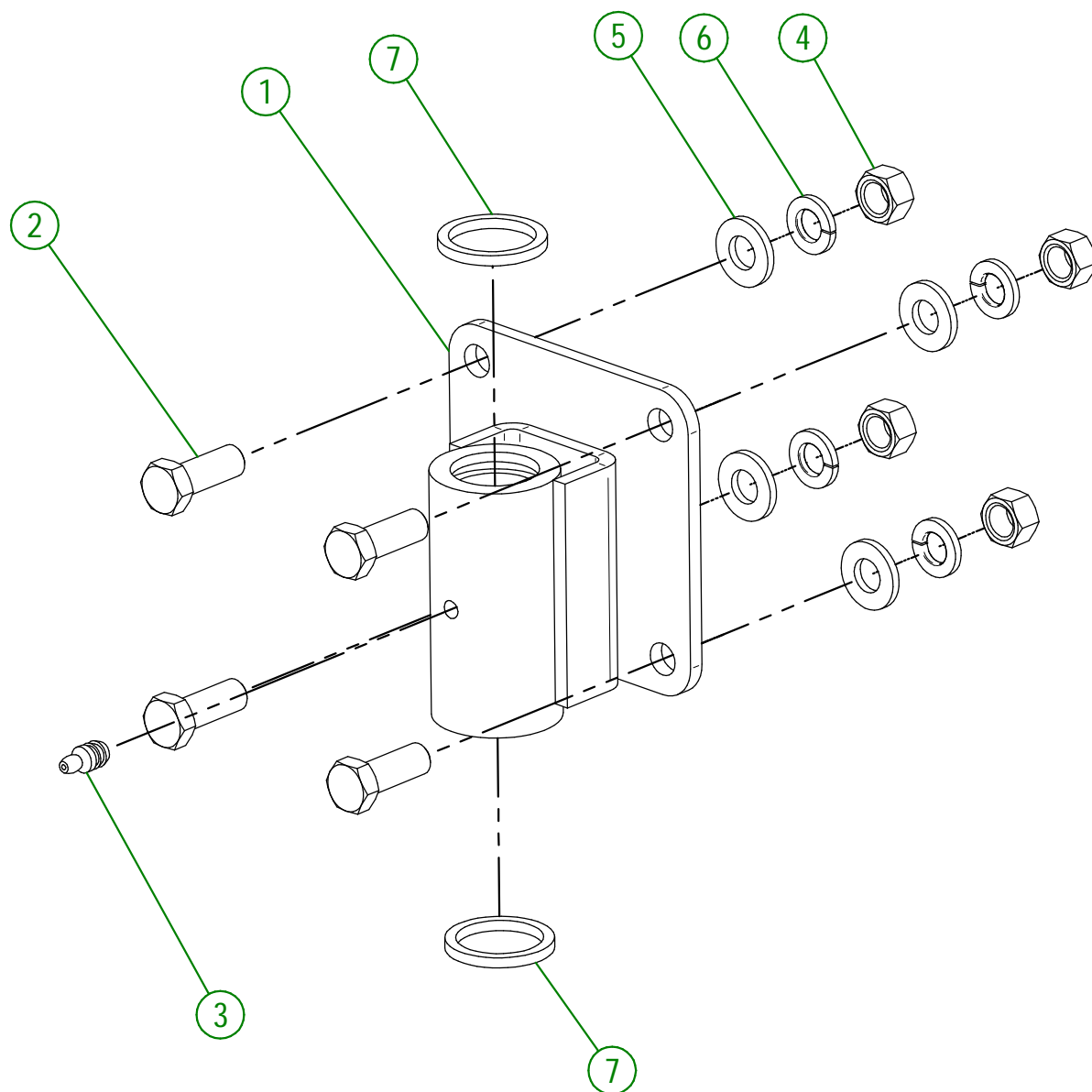

AGRIMETAL	
SWIVEL WHEEL SUPPORT ASSY GROUP	
CREATION : 23/04/25	ASSEMBLY : 22-57-0005
REVISION : 23/04/25	AUTHOR : N. GOULET

50-57-0050

#	PART #	Qty	TITLE
1	04-33-0220	3	FLAT WASHER 1 1/2" DIA. X 1"
2	22-04-0235	1	CASTER GAUGE SLEEVE 1/4" THICK
3	22-04-0237	6	CASTER GAUGE SLEEVE 1/2" THICK
4	22-13-1005	1	SWIVEL WHEEL AXLE Ø 3/4" X 4 1/2" LG
5	50-55-0011	1	SWIVEL CASTER "STICKER INCLUDED"
6	NC01-25-0114	2	HEX. BOLT GR2 ZINC 3/8-16 X 1"
7	NC01-69-1100	1	LINCH PIN 3/8"
8	NC02-22-0010	2	WASHER 13/32" ID
9	NC02-32-0012	2	LOCK WASHER ZINC 3/8"
10	NC14-70-0076	1	TIRE ONLY 9 X 3.50-4

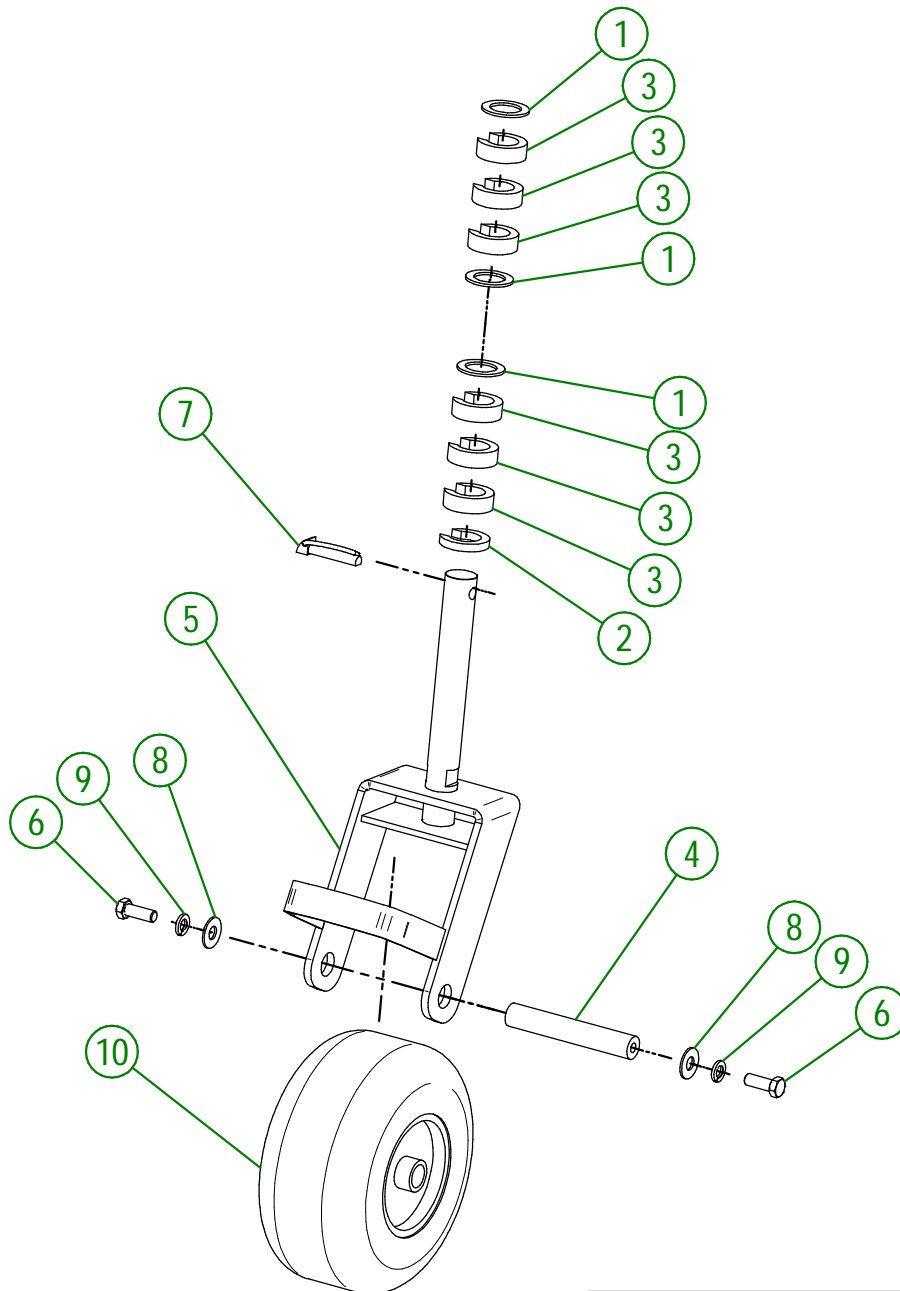

AGRIMETAL	
LEFT SWIVEL WHEEL ASSY INCLUDED HARDWARE GROUP	
CREATION : 23/04/25	ASSEMBLY : 50-57-0050
REVISION : 23/04/25	AUTHOR : N. GOULET

50-57-1060

#	PART #	Qty	TITLE
1	50-50-1015	1	3 POINT HITCH SUPPORT
2	NC01-29-0408	2	HEX. BOLT GR2 ZINC 5/8-18 X 5"
3	NC02-10-0022	2	HEX. NUT ZINC 5/8-18
4	NC02-22-0013	4	WASHER ZINC 5/8 ID X 1 1/2 OD
5	NC02-32-0016	2	LOCK WASHER ZINC 5/8"

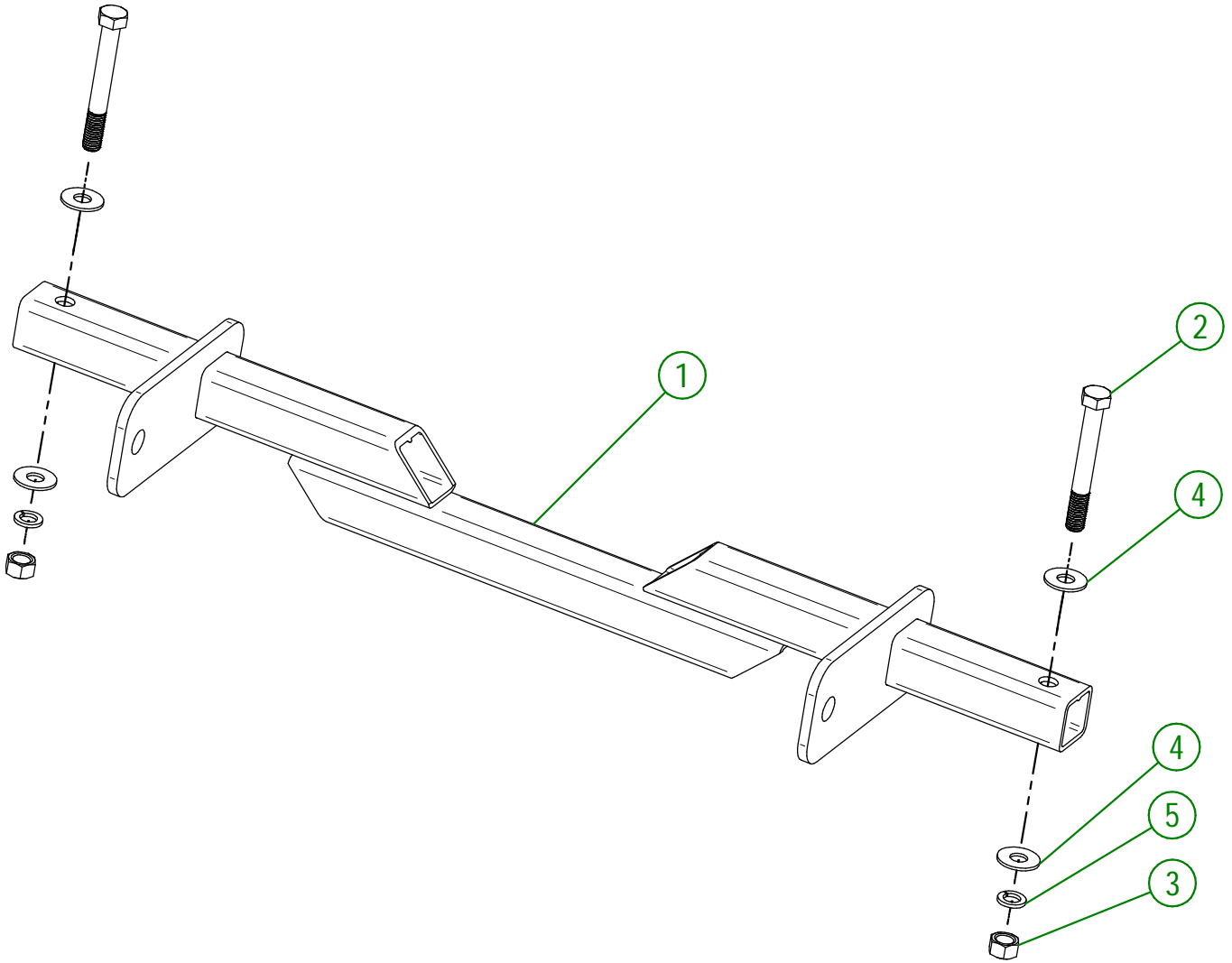

AGRIMETAL

3 POINT HITCH SUPPORT GROUP HARDWARE INCLUDED

CREATION : 23/04/25
 REVISION : 23/04/25

ASSEMBLY : **50-57-1060**
 AUTHOR : N. GOULET

50-57-1035

#	PART #	Qty	TITLE
1	01-41-0910	1	KEY
2	22-21-0025	1	IDLER PULLEY BUSHING
3	22-41-0080	2	TENSION BELT BUSHING
4	22-55-0120	1	PILLOW BLOCK BEARING UCF 205-16 Ø 1"
5	50-21-0000	1	IDLER PULLEY ONLY
6	50-41-0900	1	SQUARE KEY 1/4" X 1/4" X 1 3/4" LG
7	50-50-0050	1	BELT TIGHTENER PIVOT
8	50-50-1000	1	DRIVE SHAFT (MOD.690)
9	NC01-07-0110	4	CARR. BOLT GR5 ZINC 3/8-16 X 1 1/4"
10	NC01-25-0117	1	HEX. BOLT GR5 ZINC 3/8-16 X 1 3/4" LG
11	NC01-64-0142	1	SNAP RING HOLE 1 3/8"
12	NC02-07-0018	5	HEX. NUT ZINC 3/8-16
13	NC02-25-0009	1	WASHER 0.406" I.D. X 0.815 O.D.
14	NC02-32-0012	5	LOCK WASHER ZINC 3/8"
15	NC02-44-0088	1	ALLENS SET SCREW 1/4-20 X 1/4" LG.
16	NC02-44-0102	2	SOCKET HEAD CAP SCREW 5/16-18 X 5/16"
17	NC02-44-0103	2	SET SCREW 5/16-18 X 3/8"
18	NC13-85-0008	1	GALVANISED SPRING
19	NC14-62-0147	1	PULLEY 2MA60 X Ø 1" KW 1/4" 2SS 5/16"-18
20	NC14-75-0068	1	BALL BEARING 99502H

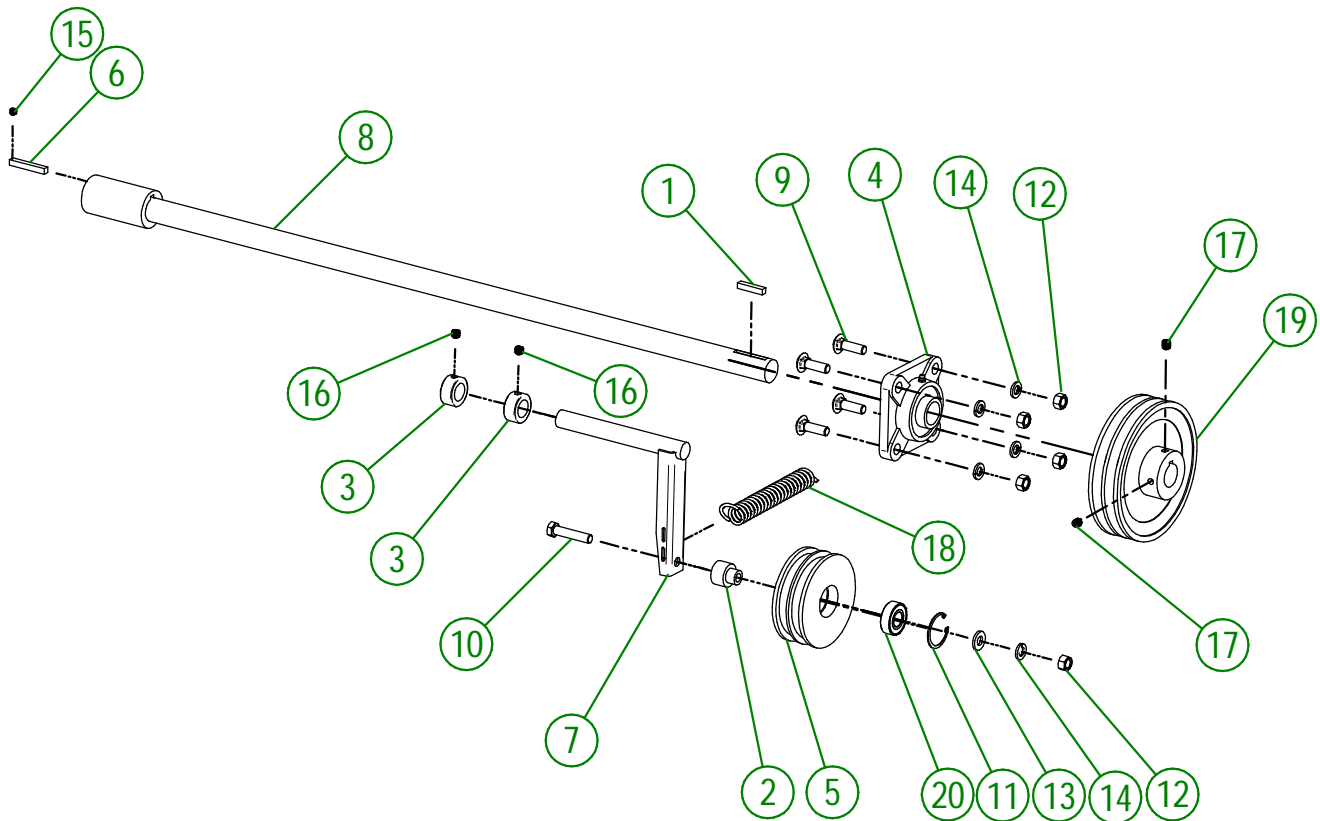

AGRIMETAL	
IDLER PULLEY ASSY GROUP	
CREATION : 23/04/25	ASSEMBLY : 50-57-1035
REVISION : 23/04/25	AUTHOR : N. GOULET

50-57-0075

#	PART #	Qty	TITLE
1	21-01-0950	6	FLAT WASHER 10GA 1.005" DIA X 25/64"
2	50-03-4800	2	FLAT WASHER Ø 1 1/2" X Ø .640
3	50-07-0800	1	3 POINT HITCH BRACE
4	50-13-2800	2	FLAT WASHER Ø 2" X Ø 41/64" X 1/4"
5	50-50-0020	2	3 POINT HITCH UPRIGHT
6	50-50-0030	1	TRANSMISSION SUPPORT
7	NC01-07-0109	6	CARR. BOLT GR2 ZINC 3/8-16 X 1"
8	NC01-25-0113	4	HEX. BOLT GR5 ZINC 3/8-16 X 7/8"
9	NC01-29-0402	1	HEX. BOLT GR5 ZINC 5/8-18 X 3 1/2"
10	NC01-29-0404	1	HEX. BOLT GR5 ZINC 5/8-18 X 4"
11	NC01-78-0002	2	3 POINTS PIN 7/8-14 X 5 1/4"
12	NC02-07-0018	6	HEX. NUT ZINC 3/8-16
13	NC02-07-0022	2	HEX. NUT ZINC 5/8-11
14	NC02-22-0013	4	WASHER ZINC 5/8 ID X 1 1/2 OD
15	NC02-32-0012	10	LOCK WASHER ZINC 3/8"
16	NC02-32-0016	2	LOCK WASHER ZINC 5/8"

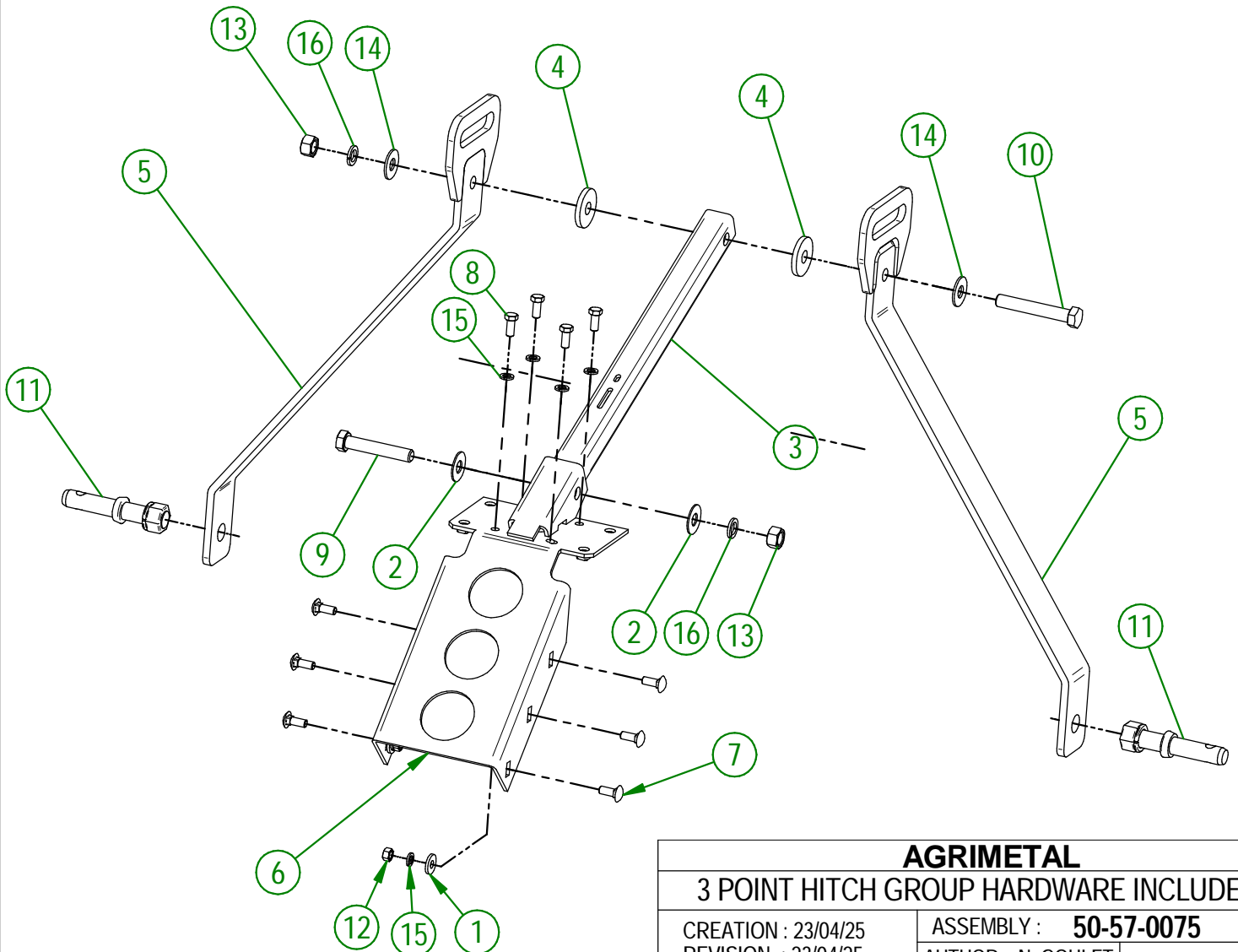

AGRIMETAL

3 POINT HITCH GROUP HARDWARE INCLUDED

CREATION : 23/04/25
 REVISION : 23/04/25

ASSEMBLY : **50-57-0075**
 AUTHOR : N. GOULET

50-57-1050

#	PART #	Qty	TITLE
1	50-03-4200	1	PTO GUARD SHIM GALVANIZED (MOD.690)
2	50-55-0065	1	PTO SHAFT GUARD "STICKER INCLUDED"
3	50-55-1050	1	RIGHT SIDE DRIVE GUARD (MOD.690) "STICKER INCLUDED"
4	NC01-62-0003	6	HEX BOLT WASHER HEAD 3/8"-16 X 3/4" LG

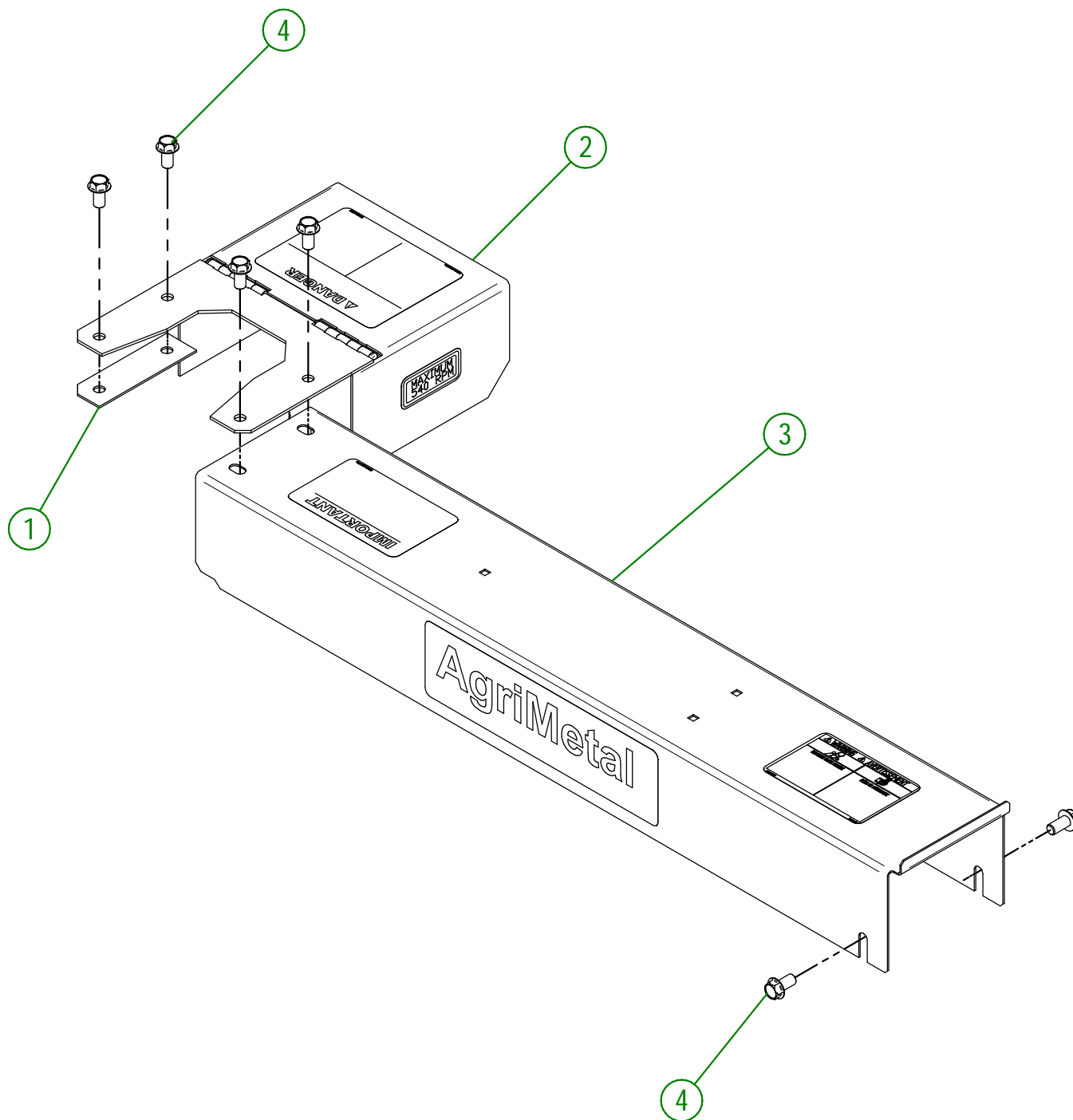

AGRIMETAL	
ASSY GUARD STRENGTH & FULL TRAINING GUARD GROUP HARDWARE INCLUDED	
CREATION : 23/04/25	ASSEMBLY : 50-57-1050
REVISION : 23/04/25	AUTHOR : N. GOULET

50-57-1040

#	PART #	Qty	TITLE
1	50-55-0045	1	BELT GUARD "STICKER INCLUDED"
2	NC01-62-0003	6	HEX BOLT WASHER HEAD 3/8"-16 X 3/4" LG

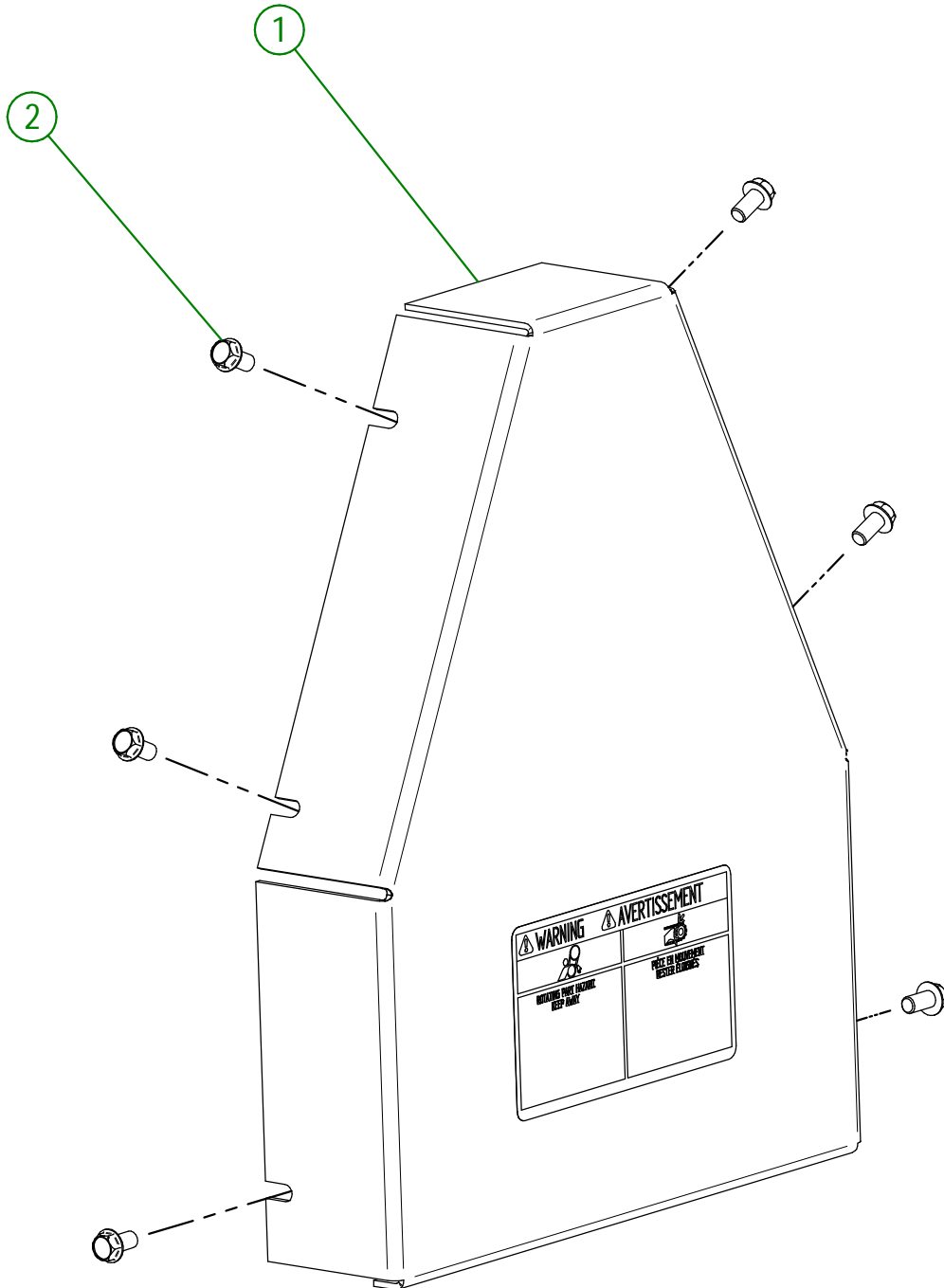

AGRIMETAL	
BELT GUARD ASSY GROUP	
CREATION : 23/04/25	ASSEMBLY : 50-57-1040
REVISION : 23/04/25	AUTHOR : N. GOULET

50-57-0085

#	PART #	Qty	TITLE
1	01-41-0910	1	KEY
2	50-34-0030	1	PTO SHAFT (T20) I 3/8" X 6 SPLINES X Ø 1" K.W. 1/4" X 34 1/4" LG
3	NC01-25-0014	1	HEX. BOLT GR5 NC ZINC 1/4-20 X 3"
4	NC01-96-0009	1	NYLON-INSERT LOCKNUT ZINC 1/4-20
5	NCI3-25-0019	2	BLACK TIE RAP

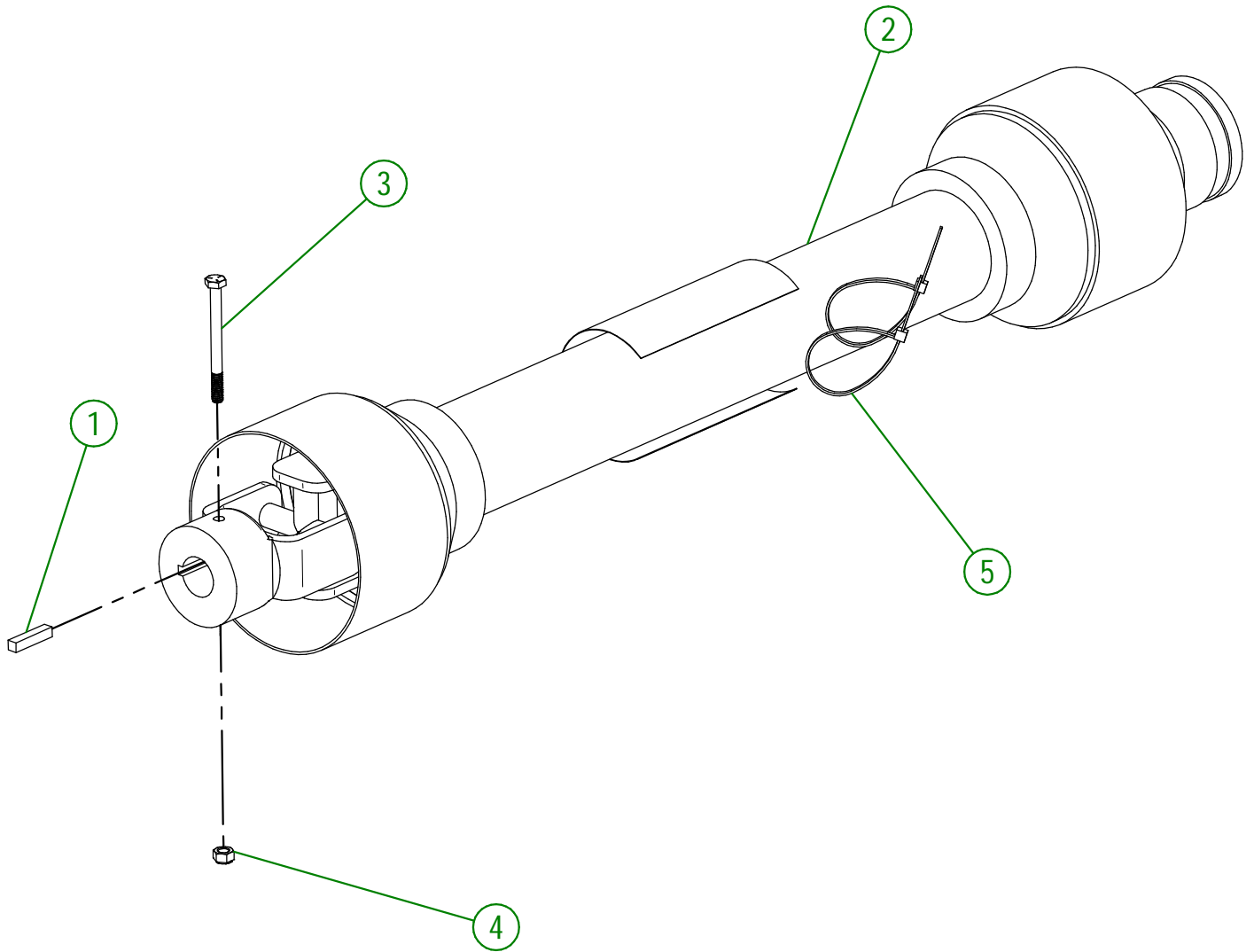

AGRIMETAL	
PTO SHAFT ASSY GROUP HARDWARE INCLUDED	
CREATION : 23/04/25	ASSEMBLY : 50-57-0085
REVISION : 23/04/25	AUTHOR : N. GOULET

#	PART #	Qty	TITLE
1	50-01-3035	1	DRAG MATT CHANNEL (MOD.690)
2	50-03-5420	1	FRAMING UNDERSIDE OF METAL CARPET (IN FRONT) 690
3	50-03-5425	1	FRAMING UNDERSIDE OF METAL CARPET (BEHIND) 690
4	50-03-5430	1	FRAMING TOP OF METAL CARPET (IN FRONT) 690
5	50-03-5435	1	FRAMING TOP OF METAL CARPET (BEHIND) 690
6	50-07-0405	3	DRAG MATT TUB
7	50-41-0000	3	CHAIN WITH LINK PASSING 4.8MM X 2/0 X 18 MESHES
8	50-41-0005	3	CHAIN WITH LINK PASSING 4.8MM X 2/0 X 14 MESHES
9	NC01-05-0005	34	CARR. BOLT GR5 FLZ 1/4-20 X 1"
10	NC01-25-0009	3	HEX. BOLT GR5 ZINC 1/4-20 X 1 3/4"
11	NC01-52-0004	3	EYEBOLT ZINC 1/4"-20 X 2 1/2" LG
12	NC01-75-0013	3	QUICK LINK 3/16-5MM DIA.
13	NC01-96-0009	40	NYLON-INSERT LOCKNUT ZINC 1/4-20
14	NC02-07-0016	3	HEX. NUT NC ZINC 1/4-20
15	NC13-15-0032	1	RUBBER STRAP
16	NC13-20-0026	1	DRAG MATT ASSY 72" WIDE X 36" LG

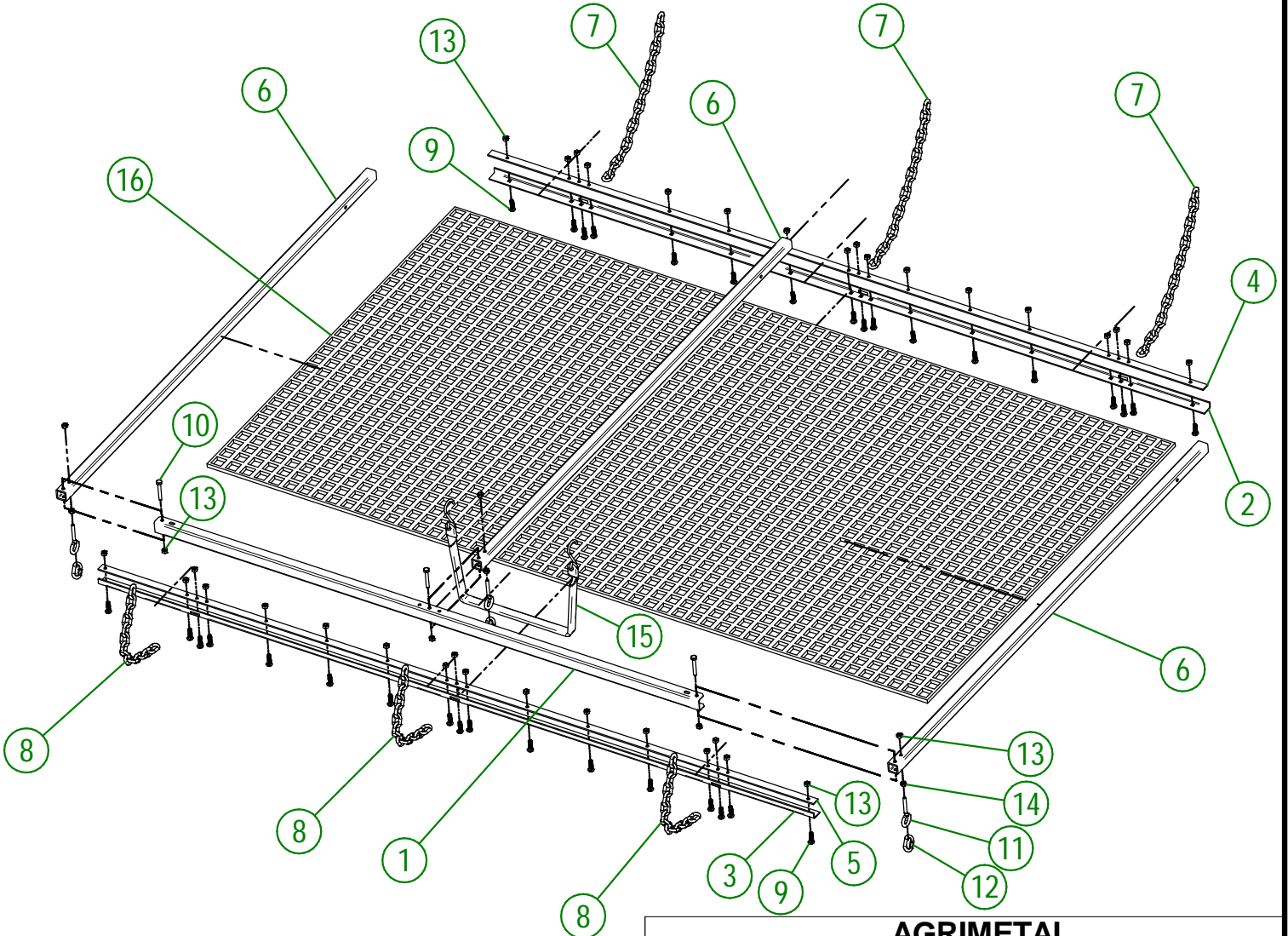

AGRIMETAL	
METAL CARPET GROUP HARDWARE INCLUDED (MOD.690)	
CREATION : 24/04/25	ASSEMBLY : 50-57-1065
REVISION : 24/04/25	AUTHOR : N. GOULET

#	PART #	Qty	TITLE
1	NC01-07-0003	3	CARR. BOLT GR5 ZINC 1/4-20 X 3/4"
2	NC01-96-0009	3	NYLON-INSERT LOCKNUT ZINC 1/4-20
3	NC02-25-0007	3	WASHER ZINC 0.281 = 9/32
4	NCI3-30-0237	1	PLASTIC TUBE FOR OPERATOR'S MANUAL

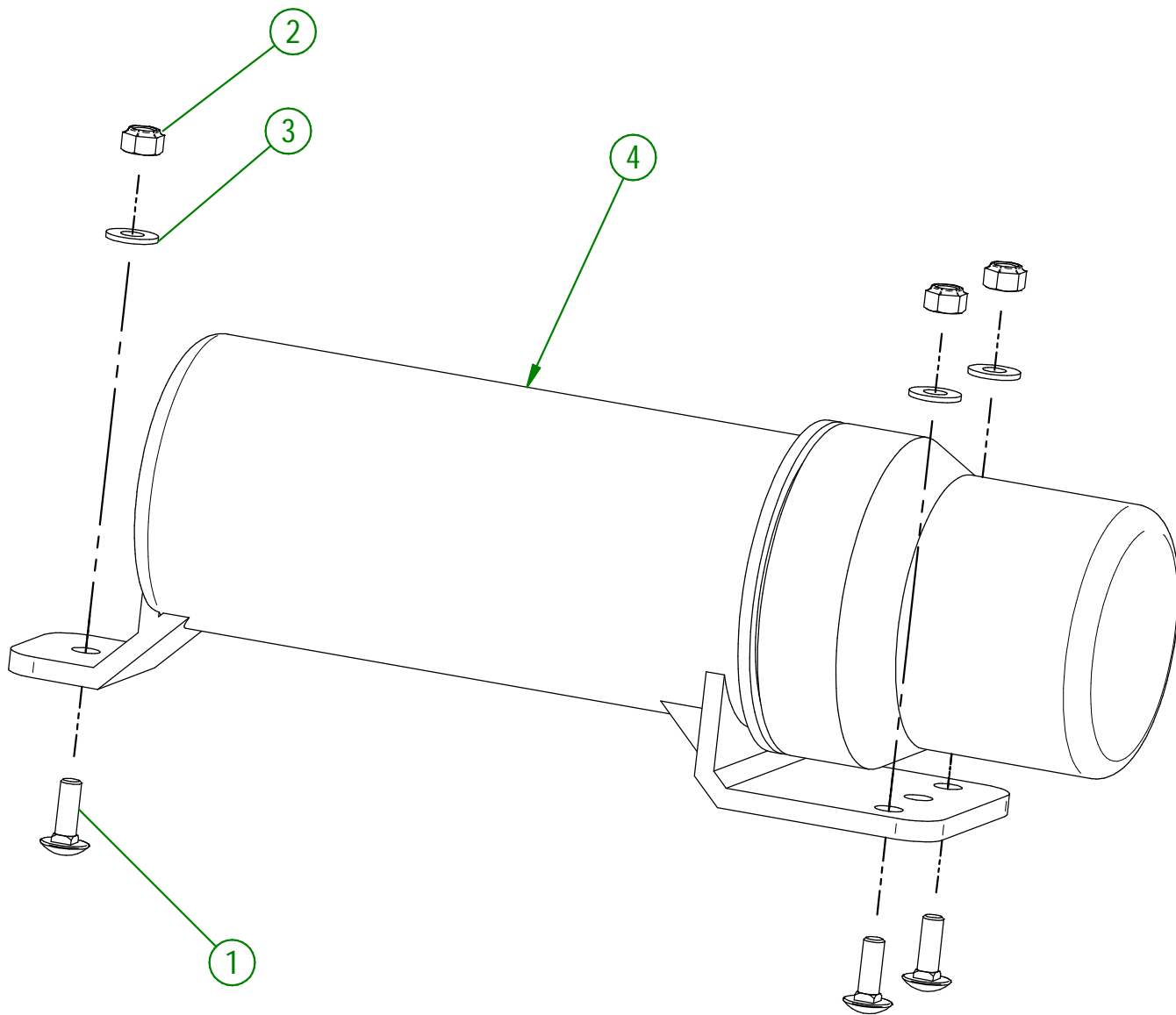

AGRIMETAL	
CAPSULE OPERATOR MANUAL CORE BREAKER GROUP (MOD.690)	
CREATION : 24/04/25	ASSEMBLY : 50-57-0100
REVISION : 24/04/25	AUTHOR : N. GOULET

#	PART #	QTY	TITLE
1	NCI3-33-0005	2	STICKER MAXIMUM 540 RPM
2	NCI3-33-0009	1	STICKER WARNING
3	NCI3-33-0017	1	STICKER WARNING
4	NCI3-33-0018	1	STICKER WARNING
5	NCI3-33-0020	1	STICKER DANGER
6	NCI3-33-0024	8	STICKER GREASE HERE
7	NCI3-33-0035	2	STICKER AGRIMETAL
8	NCI3-33-0098	4	STICKER WARNING
9	NCI3-33-0113	1	STICKER WARNING
10	NCI3-33-0122	4	STICKER IMPORTANT
11	NCI3-33-0126	1	STICKER CAUTION
12	NCI3-33-0179	1	STICKER IMPORTANT GREASE DRIVE LINE
13	NCI4-85-0276	1	STICKER (DANGER-PLASTIC GUARD)

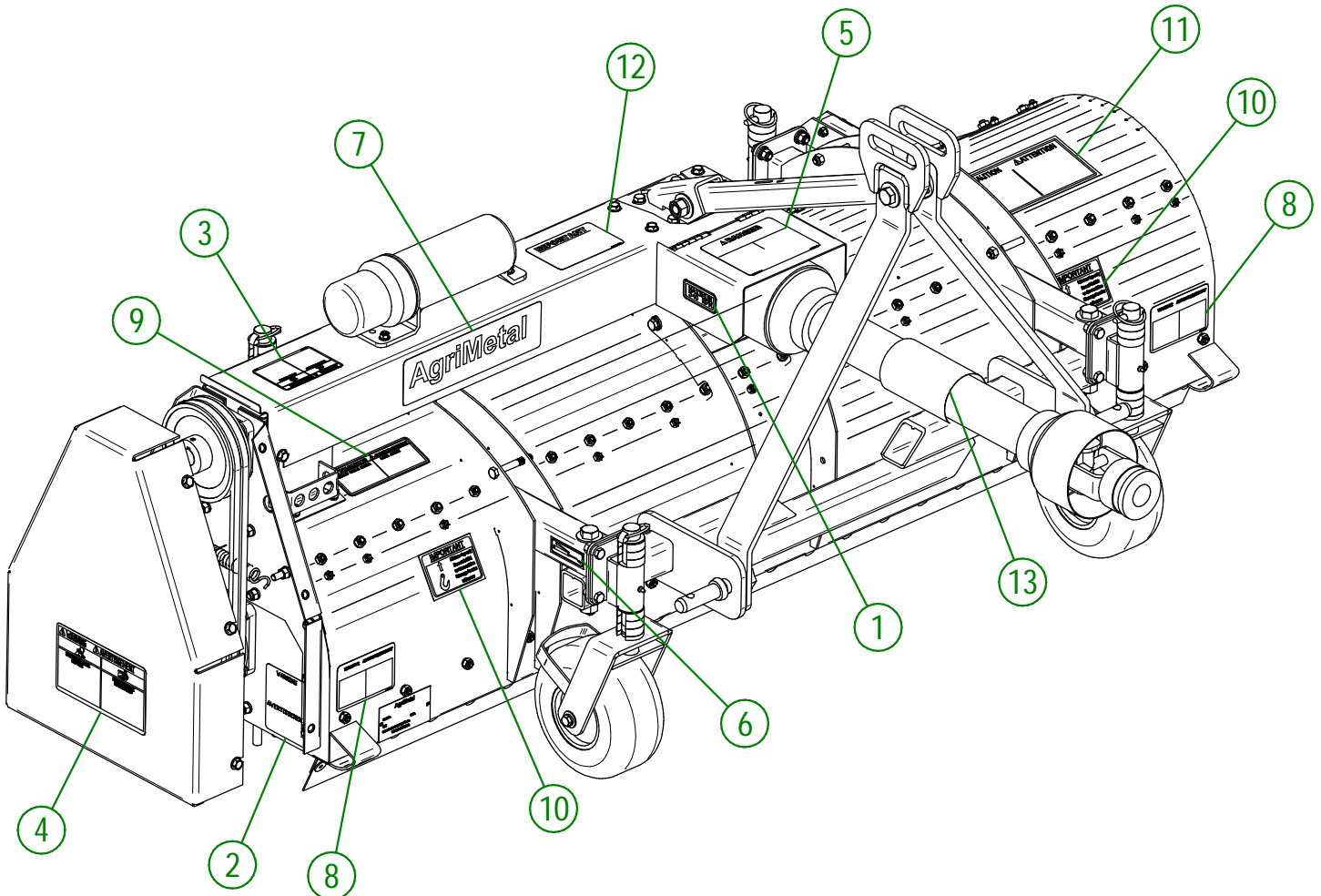

AGRIMETAL
CORE BREAKER MOD.690

CREATION : 12/02/26
REVISION : 12/02/26

ASSEMBLY : **50-99-0006**
AUTHOR : N. GOULET

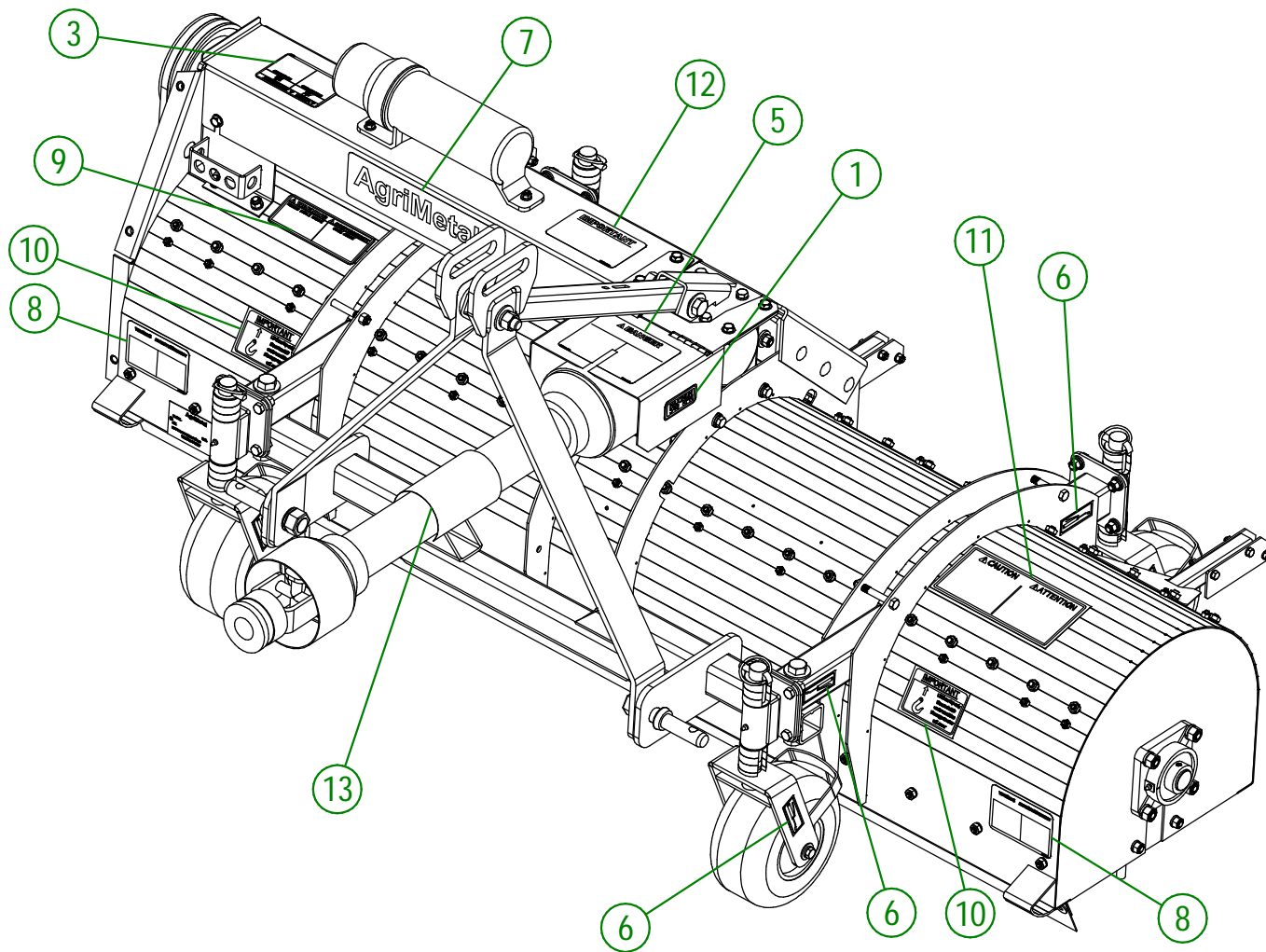

AGRIMETAL	
CORE BREAKER MOD.690	
CREATION : 12/02/26	ASSEMBLY : 50-99-0006
REVISION : 12/02/26	AUTHOR : N. GOULET