

AgriMetal

PARTS LIST

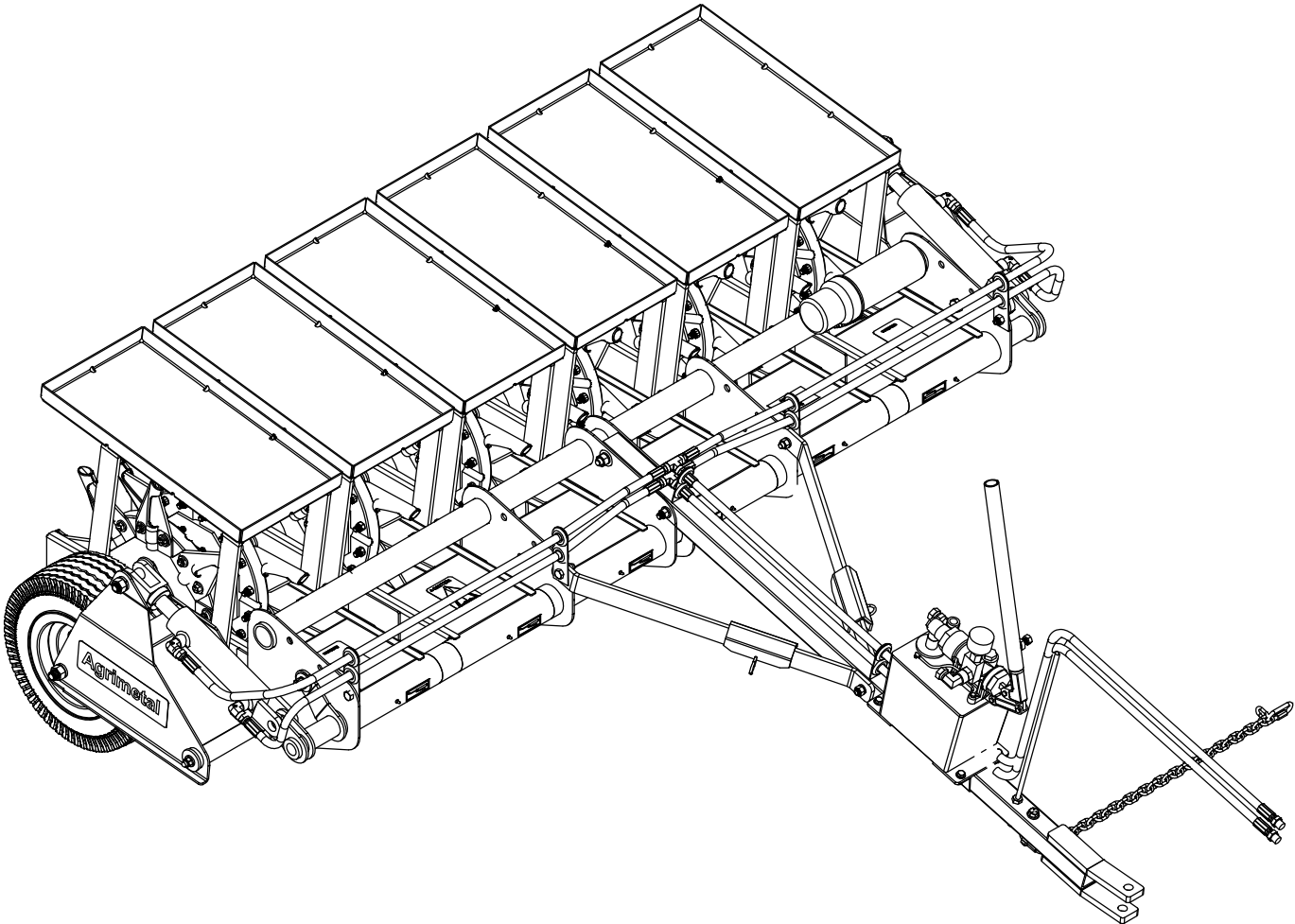

FA-720 B (WIDE WHEEL)

#	PART #	Qty	TITLE
1	NC01-29-0187	192	HEX. BOLT GR5 NF ZINC 7/16-20 X 2 1/2"
2	NC01-94-0012	192	HEX. BLOC NUT NF 7/16-20
3	NC02-22-0010	192	WASHER 13/32" ID
4	NC13-20-0009	96	KNIFE

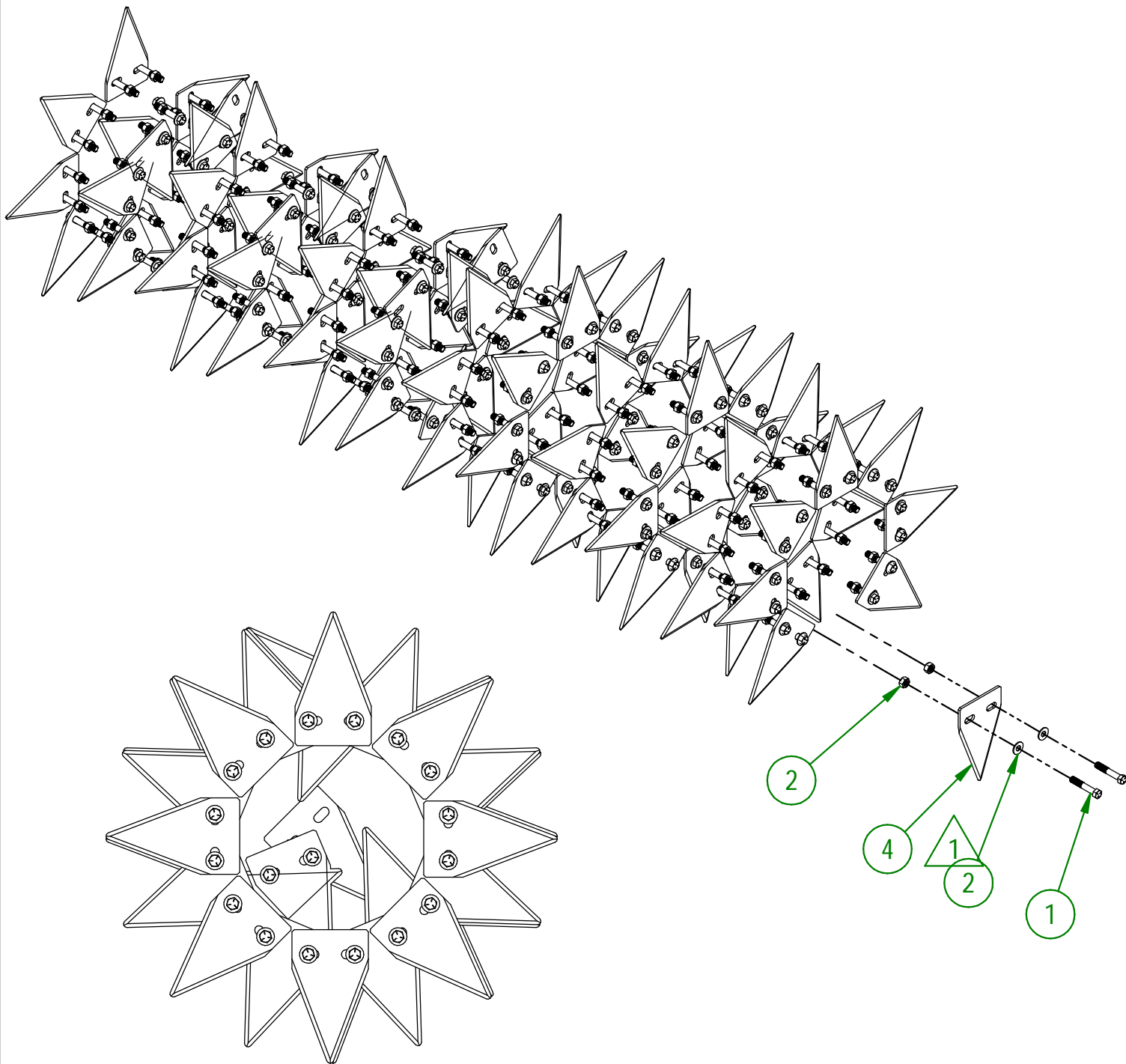

AGRIMETAL	
KNIVES AND HARDWARE STORE ASSY. F.A 720	
CREATION : 11/04/18	ASSEMBLY : 21-55-0185
REVISION : 27/02/26	AUTHOR : J.KABWE

#	PART #	Qty	TITLE
1	NCI3-20-0007	96	3/4" AERATOR FINGER
2	21-04-0040	96	ROUTING CLAMP 7GA X 3 7/8" X 1 1/4"
3	NC01-29-0185	192	HEX. BOLT GR5 NF ZINC 7/16-20 X 2 1/4'
4	NC01-94-0012	192	HEX. BLOC NUT NF 7/16-20

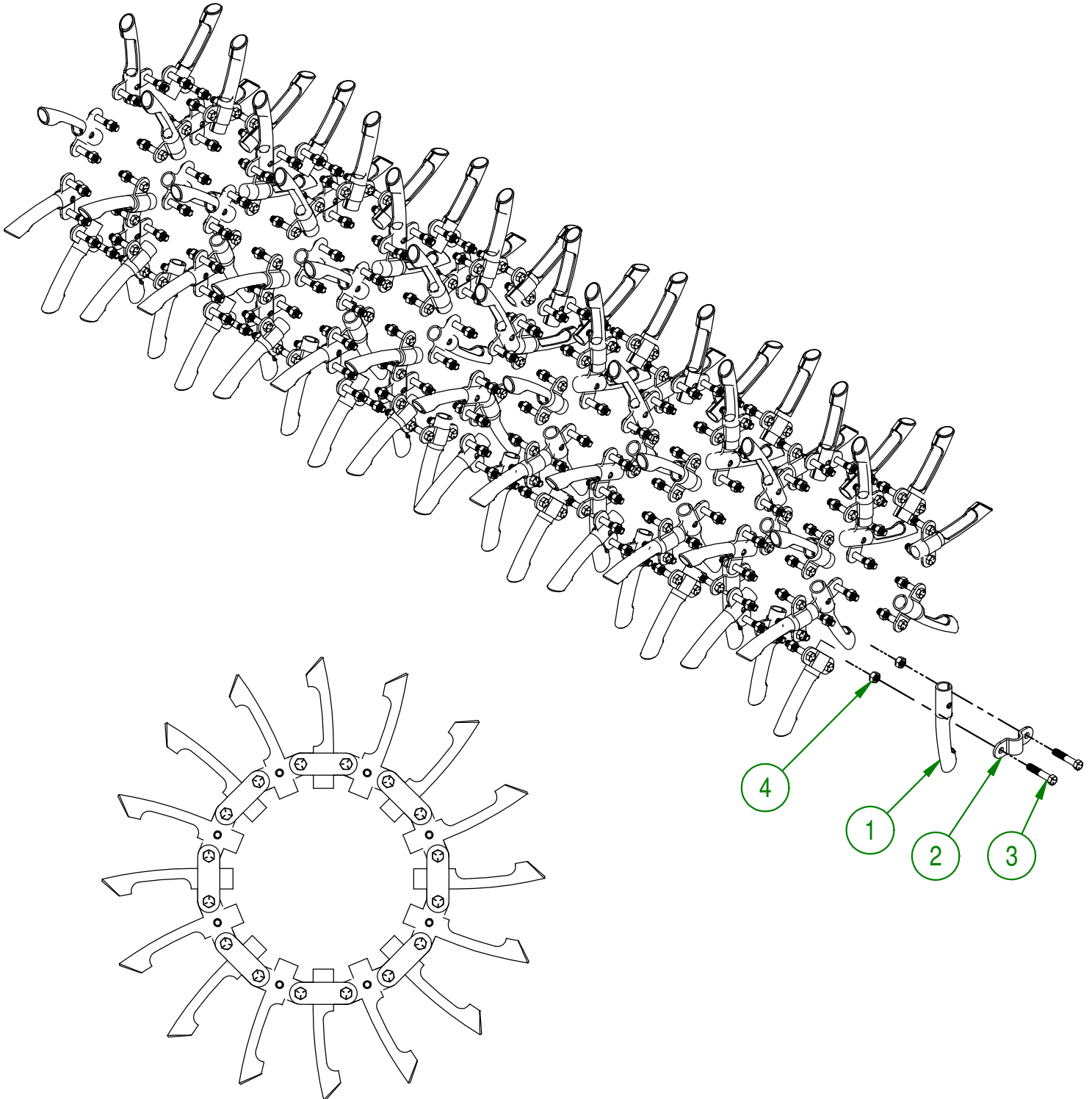

AGRIMETAL	
KNIVES AND HARDWARE STORE ASSY.	
CREATION : 11/04/18	ASSEMBLY : 21-55-0180
REVISION : 11/04/18	AUTHOR : J.KABWE Page 2 de 12

21-55-0140

#	PART #	Qty	TITLE
1	NC13-45-0090	1	MANUAL HYDRAULIC PUMP 2.19 PO. CUBE
2	NC13-45-0093	1	ELBOW 90-1/2 FEMALE NPT X 3/8 MALE NPT
3	NC13-45-0092	1	T 1/2 MALE NPT X 1/2 FEM. NPT X 1/2 FEM. NPT
4	NC13-45-0091	1	STRAIGHT HOSE FITTING 1/2 MALE NPTF X 1/2 FEM. SWIVEL
5	21-55-0175	1	HYDRAULIC PUMP HANDLE ASSY. (F.A 720)
6	NC01-17-0114	4	HEX. BOLT GR2 ZINC 3/8-16 X 1"
7	NC02-32-0012	4	LOCK WASHER ZINC 3/8"
8	NC02-07-0018	4	HEX. NUT ZINC 3/8-16
9	21-01-7515	1	HYDRAULIC MANUAL PUMP SUPPORT
10	01-01-2485	8	FLAT WASHER

21-55-0175

#	PART #	Qty	TITLE
11	21-50-0060	1	HYDRAULIC PUMP HANDLE (F.A 720)
12	NC01-17-0247	1	HEX. BOLT GR2 ZINC 1/2-13 X 1"

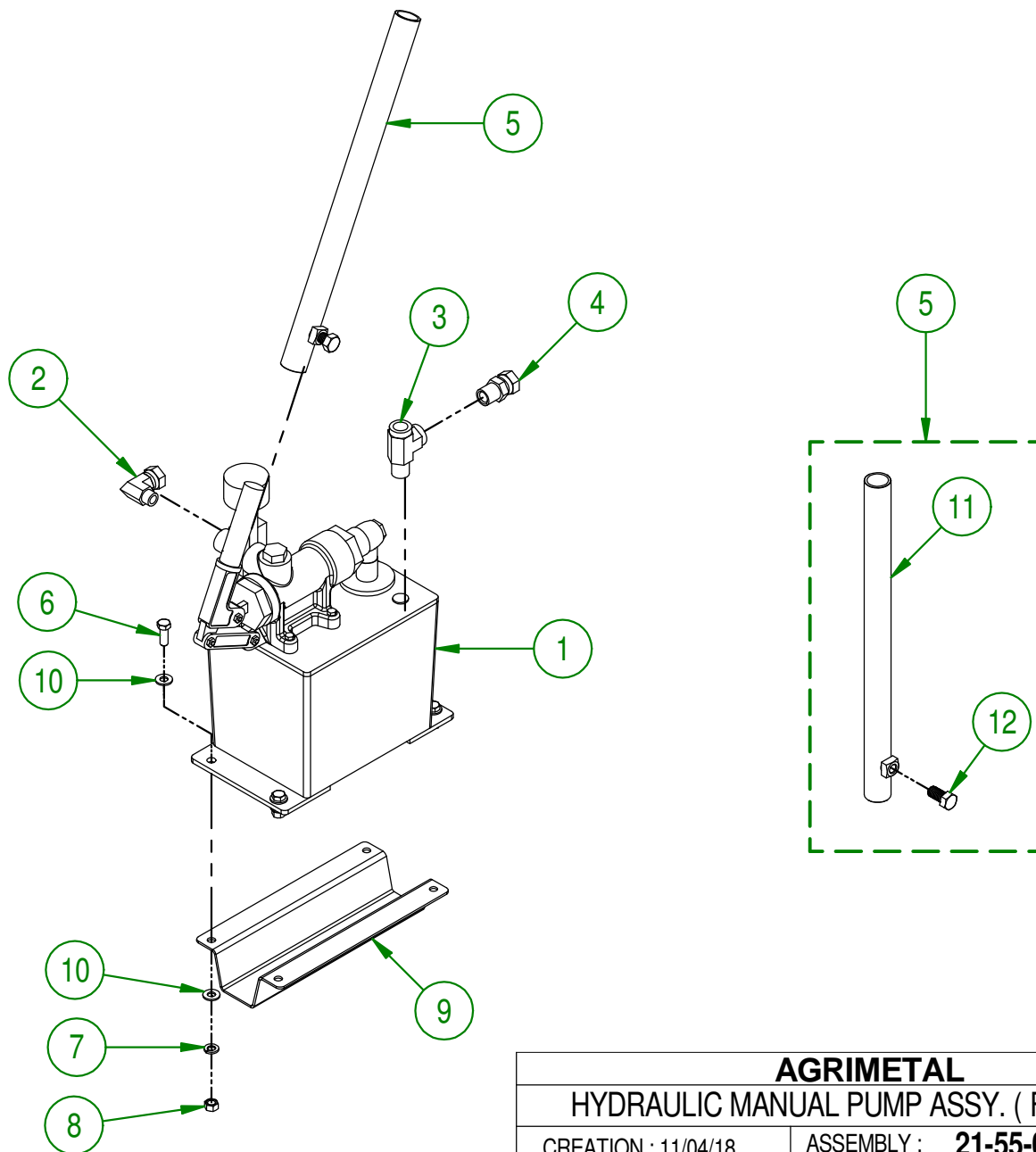

AGRIMETAL	
HYDRAULIC MANUAL PUMP ASSY. (F.A. 720)	
CREATION : 11/04/18	ASSEMBLY : 21-55-0140
REVISION : 07/05/18	AUTHOR : J.KABWE Page 3 de 12

#	PART #	Qty	TITLE
1	21-50-0035	1	FRAME FA 720

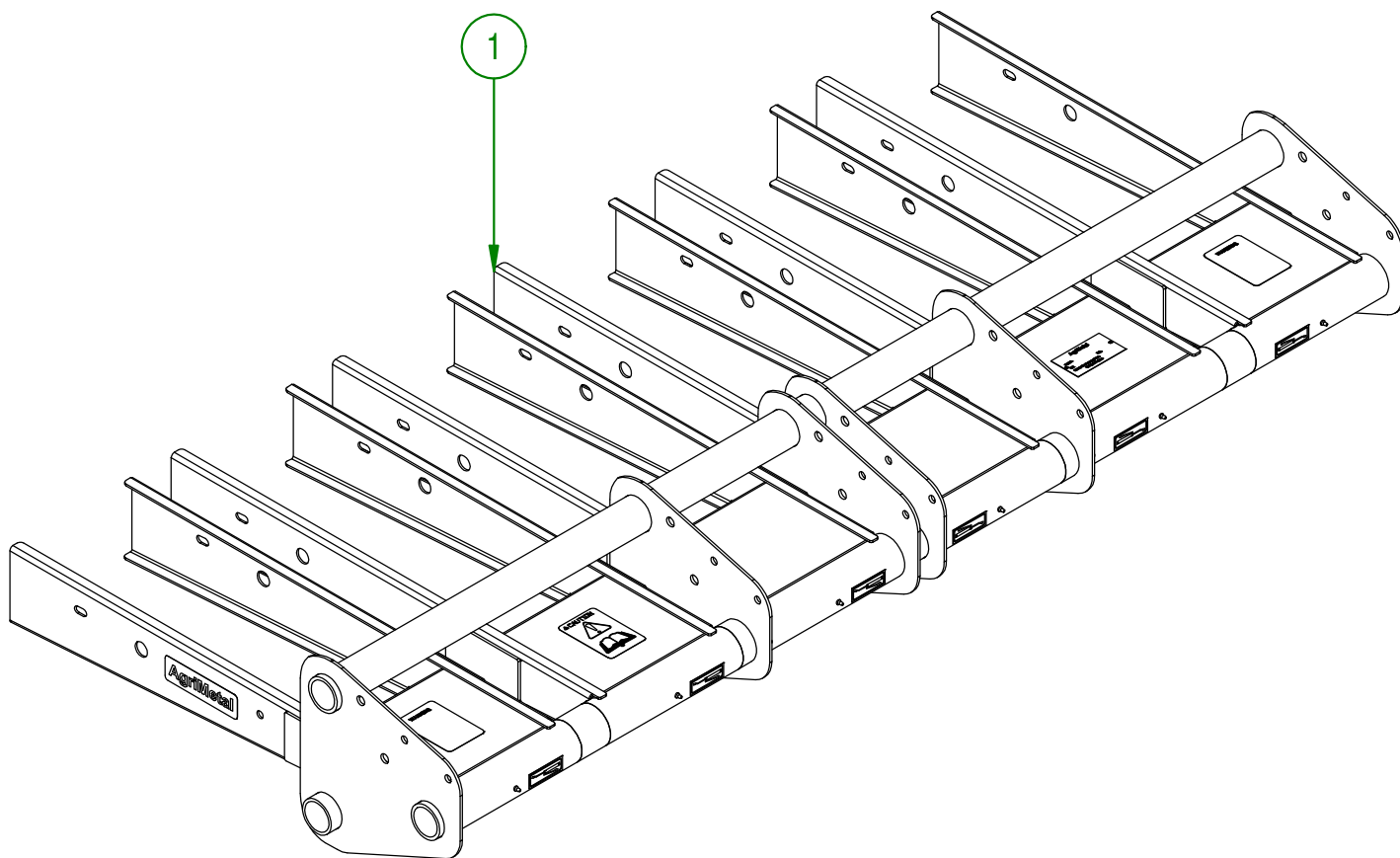

AGRIMETAL	
FRAME FA 720 GROUP.	
CREATION : 08/05/18	ASSEMBLY : 21-57-0040
REVISION : 08/05/18	AUTHOR : J.KABWE Page 4 de 12

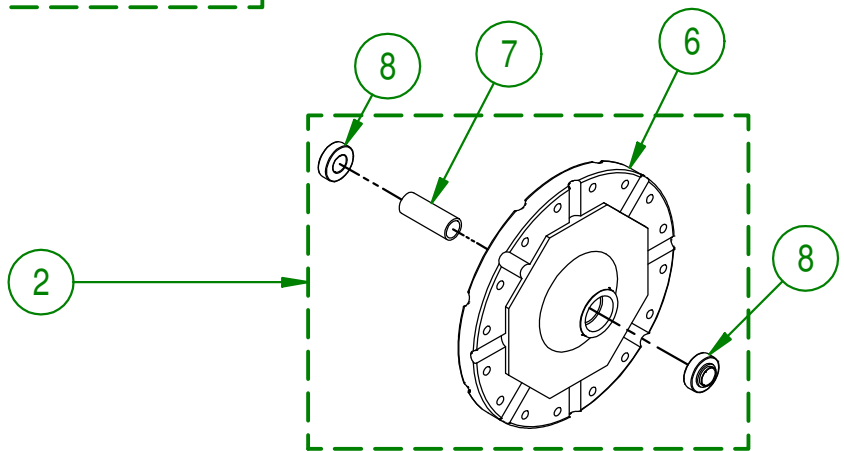
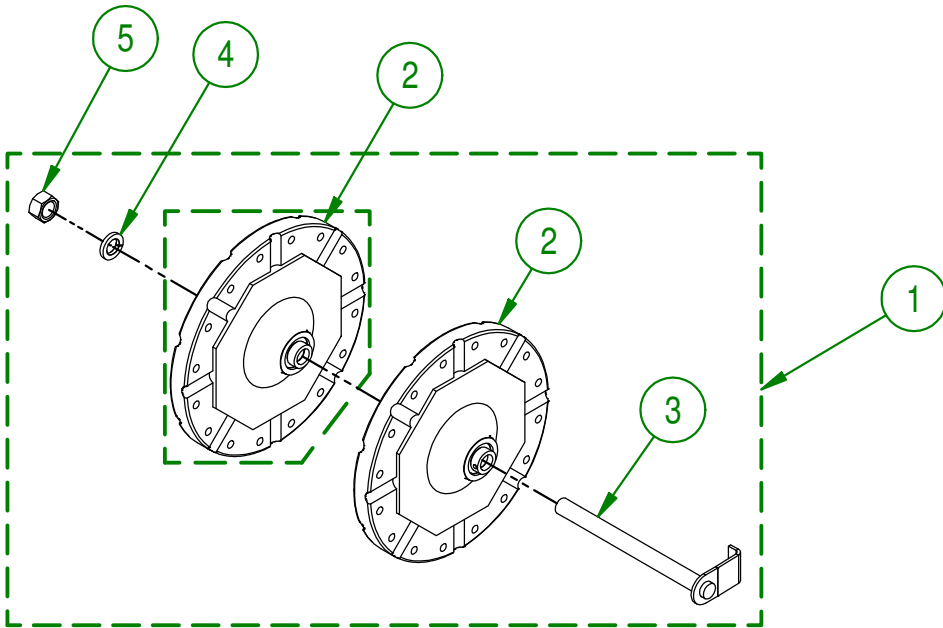
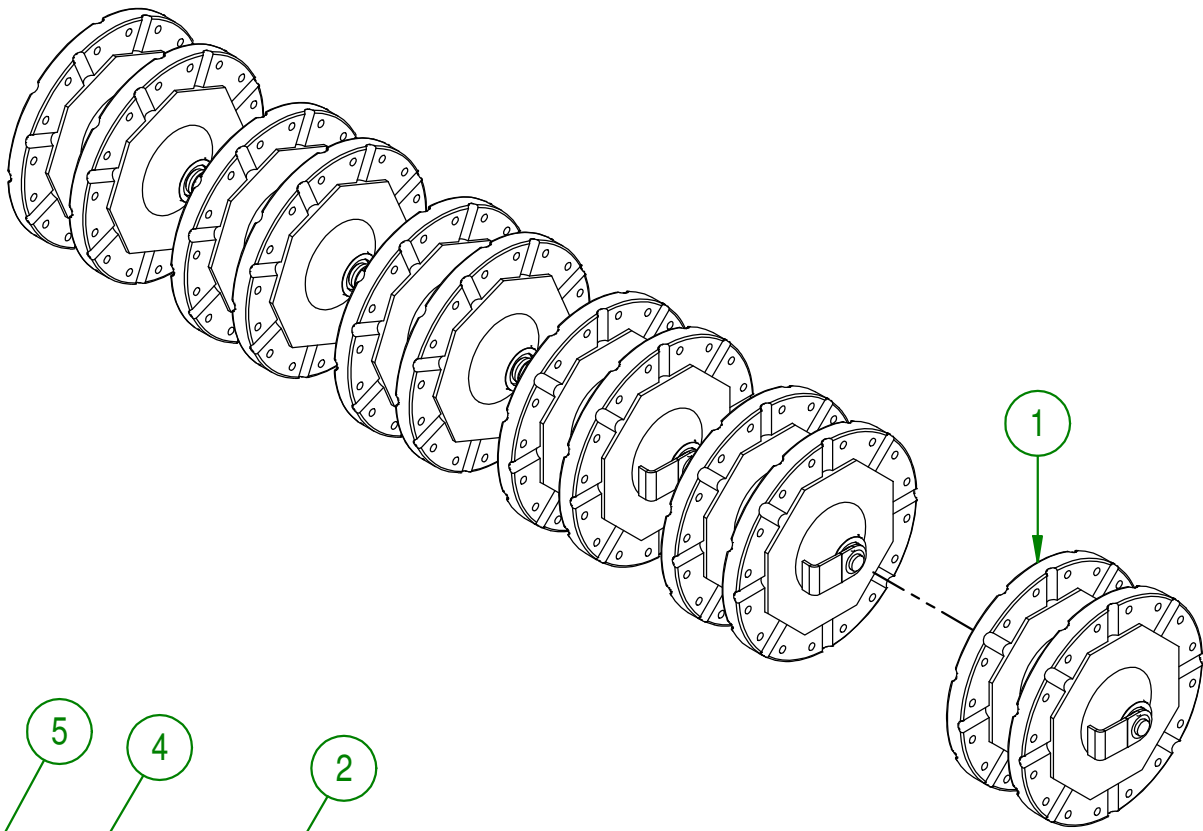

AGRIMETAL	
CAST WHEEL GROUP.	
CREATION : 11/04/18	ASSEMBLY : 21-57-0105
REVISION : 07/05/18	AUTHOR : J.KABWE Page 5 de 12

21-57-0105

#	PART #	Qty	TITLE
1	21-55-0105	6	CAST WHELL PAIR

21-55-0105

#	PART #	Qty	TITLE
2	21-55-0000	2	CAST WHEEL ASSY.
3	21-50-0020	1	CAST WHEEL AXIS
4	NC02-32-0019	1	LOCK WASHER 1"
5	NC02-10-0025	1	HEX NUT 1-14

21-55-0000

#	PART #	Qty	TITLE
6	NC13-20-0005	1	CAST WHELL
7	21-09-0200	1	BEARING SPACER
8	NC14-75-0084	2	BEARING CSA 205-16 X 1" DIA.

AGRIMETAL
CAST WHEEL GROUP.

CREATION : 11/04/18
REVISION : 07/05/18

ASSEMBLY : **21-57-0105**

AUTHOR : J.KABWE

Page 6 de 12

21-57-0065

#	PART #	Qty	TITLE
1	21-55-0065	6	SUPPORT ASSY.

21-55-0065

#	PART #	Qty	TITLE
2	21-50-0015	1	SUPPORT
3	NC01-17-0248	4	HEX. BOLT GR2 ZINC 1/2-13 X 1 1/4"
4	NC02-32-0014	4	LOCK WASHER ZINC 1/2"
5	NC02-07-0020	4	HEX. NUT ZINC 1/2-13

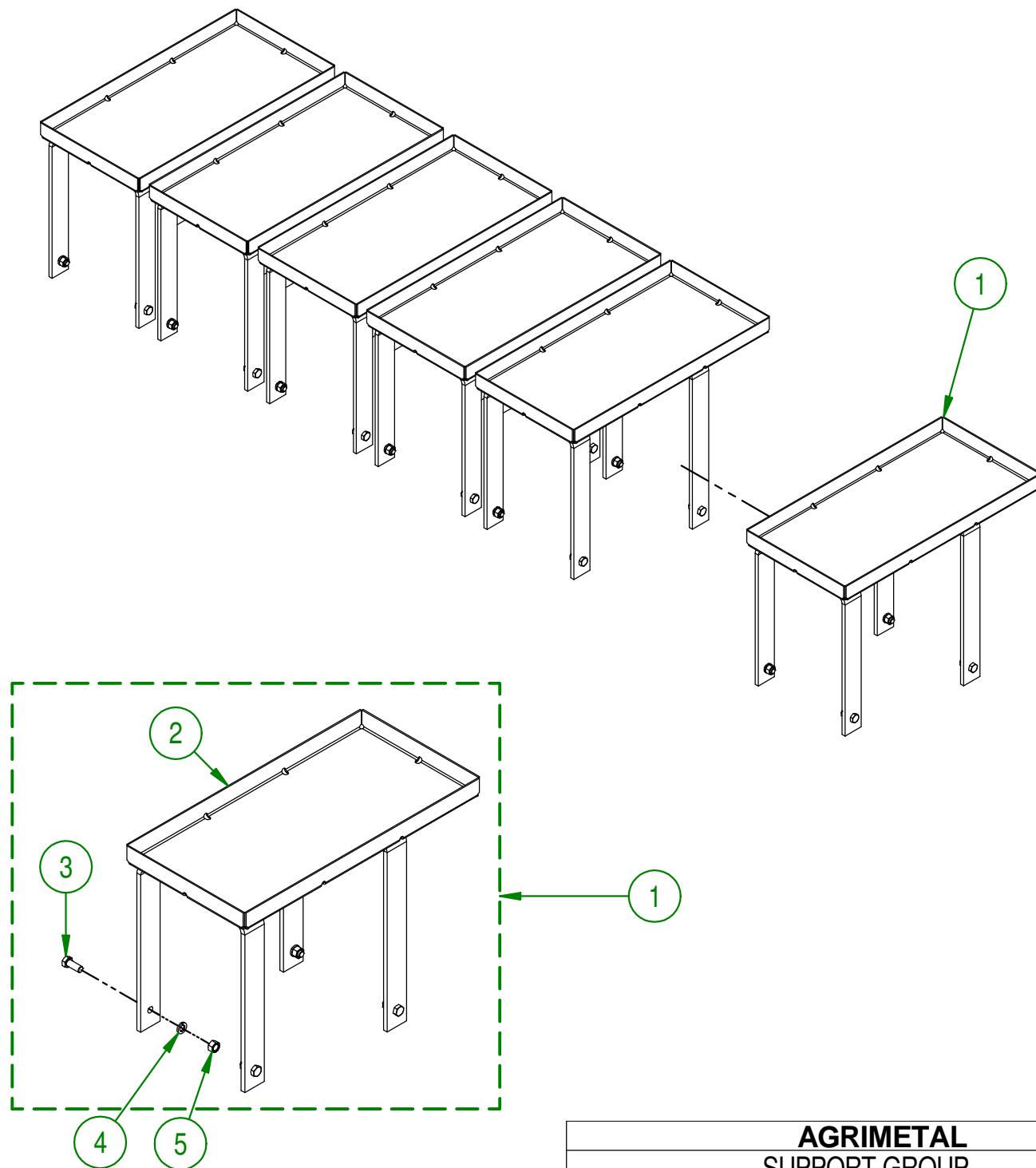

AGRIMETAL
SUPPORT GROUP.

CREATION : 11/04/18
REVISION : 07/05/18

ASSEMBLY : **21-57-0065**

AUTHOR : J.KABWE

Page 7 de 12

21-57-0101

#	PART #	Qty	TITLE
1	21-55-0100	1	HITCH ASSY.
2	NC01-90-0007	1	HEX. NUT NC Z 1/2-13 X 1 3/4"
3	NC02-07-0020	4	HEX. NUT ZINC 1/2-13
4	21-13-0601	2	WHELL SHAFT SUPPORT
5	21-13-2800	2	WHELL STOPPER SUPPORT
6	01-01-0925	2	WASHER
7	NC01-96-0014	2	NYLON-INSERT LOCKNUT ZINC 1/2-13
8	21-50-0041	1	WHEEL SUPPORT (RIGHT)
9	21-50-0001	2	HUBS ASSY.
10	NC14-75-0084	4	BEARING CSA 205-16 X 1" DIA.
11	21-09-1201	2	WHEEL AXLE RING
12	NC01-33-0491	2	HEX. BOLT GR8 NC ZINC 3/4-10 X 9"
13	NC02-32-0017	4	LOCK WASHER ZINC 3/4"
14	NC02-07-0023	4	HEX. NUT ZINC 3/4-10
15	NC01-53-0248	10	WHEEL BOLT GR5 1/2-20 X 1 5/8
16	NC14-70-0616	2	WHEEL ASSY. 16.5 X 8 DE RIM. 6 PLY WHITE F.A 720
17	21-50-0046	1	WHEEL SUPPORT (LEFT)
18	21-50-0031	2	HYDRAULIC CYLINDER SUPPORT
19	NC01-17-0394	2	HEX. BOLT GR2 ZINC 5/8-11 X 1 1/2"
20	NC02-22-0014	2	WASHER
21	NC02-32-0016	2	LOCK WASHER ZINC 5/8"
22	NC02-07-0022	2	HEX. NUT ZINC 5/8-11
23	21-50-0025	2	HYDRAULIC CYLINDER
24	21-03-0000	4	WASHER
25	NC01-25-0477	2	HEX. BOLT GR5 NC 3/4-10 X 4"
26	21-09-1205	2	BUSHING
27	21-50-0010	2	HYDRAULIC CYLINDER STOPPER (F.A 720)
28	NC01-63-0027	2	HAIRPIN COTTER
29	NC13-45-0038	4	ELBOW 90 3/8 FEM. NPT X 3/8 MALE NPT
30	21-01-2405	4	HYDRAULIC HOSE SUPPORT
31	NC13-15-0014	8	RUBBER WIRE WASHER
32	NC01-17-0247	2	HEX. BOLT GR2 ZINC 1/2-13 X 1"
33	NC13-45-0034	2	T 3/8 FEM. NPT X 3/8 FEM. NPT X 3/8 FEM. NPT
34	NC17-02-0346	2	HYDRAULIC HOSE 3/8" X 84" CUT. 3/8 NPT MAL. X 1/2 NPT MAL.
35	NC17-02-0344	1	HYD. HOSE 3/8" X 50" CUT. 3/8NPT MAL. 1/2NPT MAL.
36	NC17-02-344	1	HYD. HOSE 3/8" X 50" CUT. 3/8 NPT MAL. 1/2 NPT MAL.
37	NC17-02-0345	1	HYDR. HOSE 3/8" X 56" CUT. 3/8 NPT MAL. X 1/2 NPT MAL.
38	NC17-02-0345	1	HYDR. HOSE 3/8" X 56" CUT 3/8 NPT MAL. X 1/2 NPT MAL.

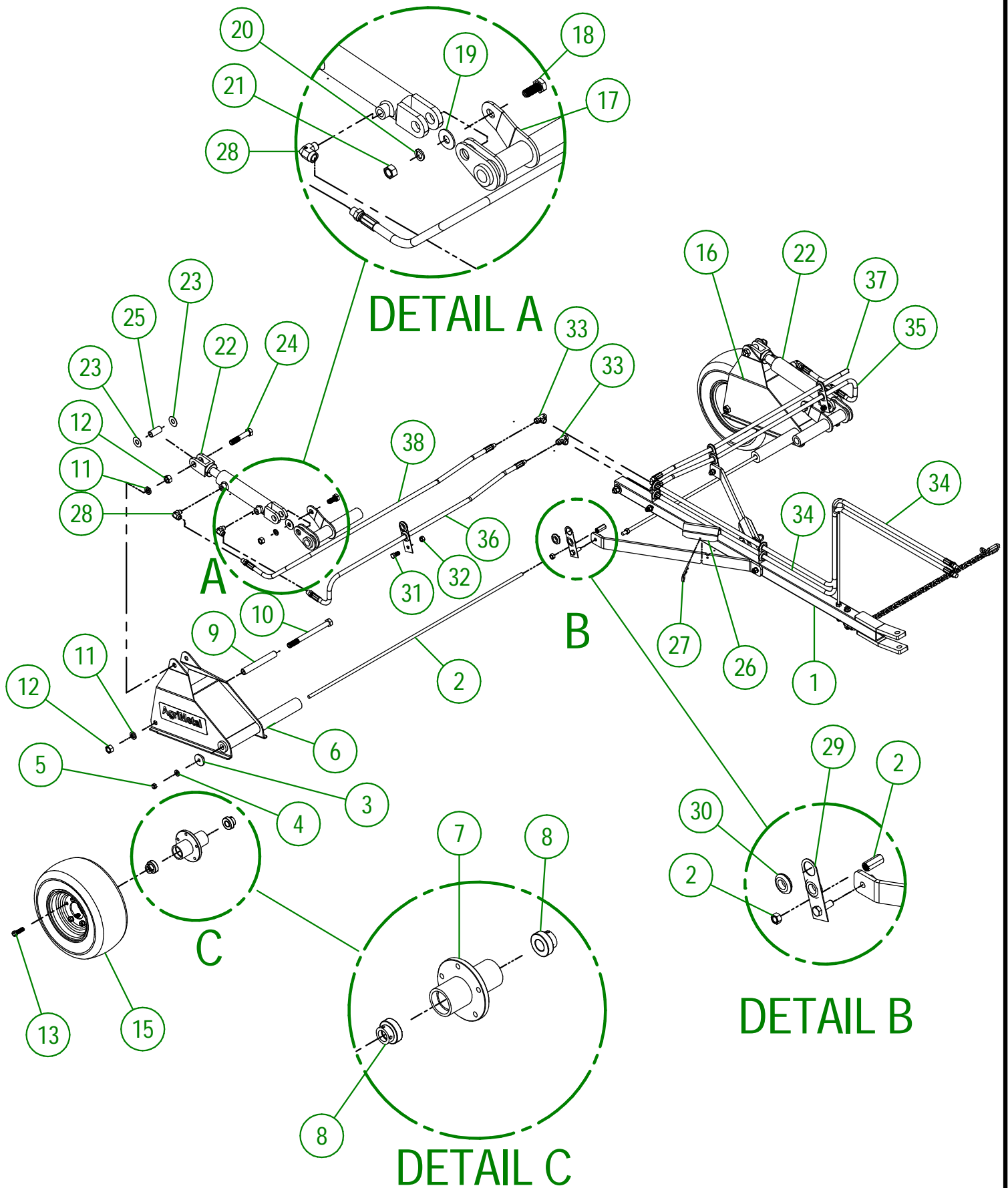

USE THESE PIECES ONLY IF YOUR SERIAL NUMBER IS AFFECTED:

#42293 AND ABOVE

AGRIMETAL	
HYD. SYSTEME & WHEEL HITCH GROUP.	
CREATION : 12/05/22	ASSEMBLY : 21-57-0102
REVISION : 12/05/22	AUTHOR : J.KABWE

21-57-0102

#	PART #	Qty	TITLE
1	21-55-0100	1	HITCH ASSY.
2	21-55-0036	1	WHEEL SHAFT SUPPORT ASSY. (F.A 720)
3	21-13-2800	2	WHELL STOPPER SUPPORT
4	01-01-0925	2	WASHER
5	NC01-96-0014	2	NYLON-INSERT LOCKNUT ZINC 1/2-13
6	21-50-0041	1	WHEEL SUPPORT (RIGHT)
7	21-50-0001	2	HUBS ASSY.
8	NC14-75-0084	4	BEARING CSA 205-16 X 1" DIA.
9	21-09-1201	2	WHEEL AXLE RING
10	NC01-33-0491	2	HEX. BOLT GR8 NC ZINC 3/4-10 X 9"
11	NC02-32-0017	4	LOCK WASHER ZINC 3/4"
12	NC02-07-0023	4	HEX. NUT ZINC 3/4-10
13	NC01-53-0248	10	WHEEL BOLT GR5 1/2-20 X 1 5/8
14*	NC13-33-0035	2	STICKER AGRIMETAL
15	NC14-70-0644	2	Wheels GR400
16	21-50-0046	1	WHEEL SUPPORT (LEFT)
17	21-50-0031	2	HYDRAULIC CYLINDER SUPPORT
18	NC01-17-0394	2	HEX. BOLT GR2 ZINC 5/8-11 X 1 1/2"
19	NC02-22-0014	2	WASHER
20	NC02-32-0016	2	LOCK WASHER ZINC 5/8"
21	NC02-07-0022	2	HEX. NUT ZINC 5/8-11
22	21-50-0025	2	HYDRAULIC CYLINDER
23	21-03-0000	4	WASHER
24	NC01-25-0477	2	HEX. BOLT GR5 NC 3/4-10 X 4"
25	21-09-1205	2	BUSHING
26	21-50-0010	2	HYDRAULIC CYLINDER STOPPER (F.A 720)
27	NC01-63-0027	2	HAIRPIN COTTER
28	NC13-45-0038	4	ELBOW 90 3/8 FEM. NPT X 3/8 MALE NPT
29	21-01-2405	4	HYDRAULIC HOSE SUPPORT
30	NC13-15-0014	8	RUBBER WIRE WASHER
31	NC01-17-0247	2	HEX. BOLT GR2 ZINC 1/2-13 X 1"
32	NC02-07-0020	2	HEX. NUT ZINC 1/2-13
33	NC13-45-0034	2	T 3/8 FEM. NPT X 3/8 FEM. NPT X 3/8 FEM. NPT
34	NC17-02-0346	2	HYDRAULIC HOSE 3/8" X 84" CUT. 3/8 NPT MAL. X 1/2 NPT MAL.
35	NC17-02-0344	1	HYD. HOSE 3/8" X 50" CUT. 3/8NPT MAL. 1/2NPT MAL.
36	NC17-02-344	1	HYD. HOSE 3/8" X 50" CUT. 3/8 NPT MAL. 1/2 NPT MAL.
37	NC17-02-0345	1	HYDR. HOSE 3/8" X 56" CUT. 3/8 NPT MAL. X 1/2 NPT MAL.
38	NC17-02-0345	1	HYDR. HOSE 3/8" X 56" CUT 3/8 NPT MAL. X 1/2 NPT MAL.

#	PART #	Qty	TITLE
1	21-50-0005	1	HITCH F.A 720
2	21-04-0610	2	HITCH SUPPORT
3	21-50-0050	1	HYDRAULIC HOSE SUPPORT F.A 720
4	NC02-32-0014	4	LOCK WASHER ZINC 1/2"
5	NC02-07-0020	1	HEX. NUT ZINC 1/2-13
6	NC01-29-0257	2	HEX. BOLT GR.5 NF 1/2-20 X3 1/2"
7	NC02-10-0020	4	HEX. NUT ZINC 1/2-20
8	21-41-0000	1	SAFETY CHAIN
9	01-01-0925	7	WASHER
10	NC01-29-0258	1	HEX. BOLT GR5 NF ZINC 1/2-20 X 3 3/4"
11	NC01-75-0015	2	RAPID LINK DIA. 5/16"-8MM, 1300-1760 LBS WLL
12	NC01-97-0008	1	HEX. LOCK NUT NYLO. NF Z 1/2-20
13	NCI3-15-0014	4	RUBBER WIRE WASHER
14	NC01-29-0249	2	HEX. BOLT GR5 NF ZINC 1/2-20 X 1 1/2"
15	NC02-22-0013	2	WASHER ZINC 5/8 ID X 1 1/2 OD
16	NC01-29-0402	1	HEX. BOLT GR5 ZINC 5/8-18 X 3 1/2"
17	NC02-10-0022	1	HEX. NUT ZINC 5/8-18
18	NC02-32-0016	1	LOCK WASHER ZINC 5/8"

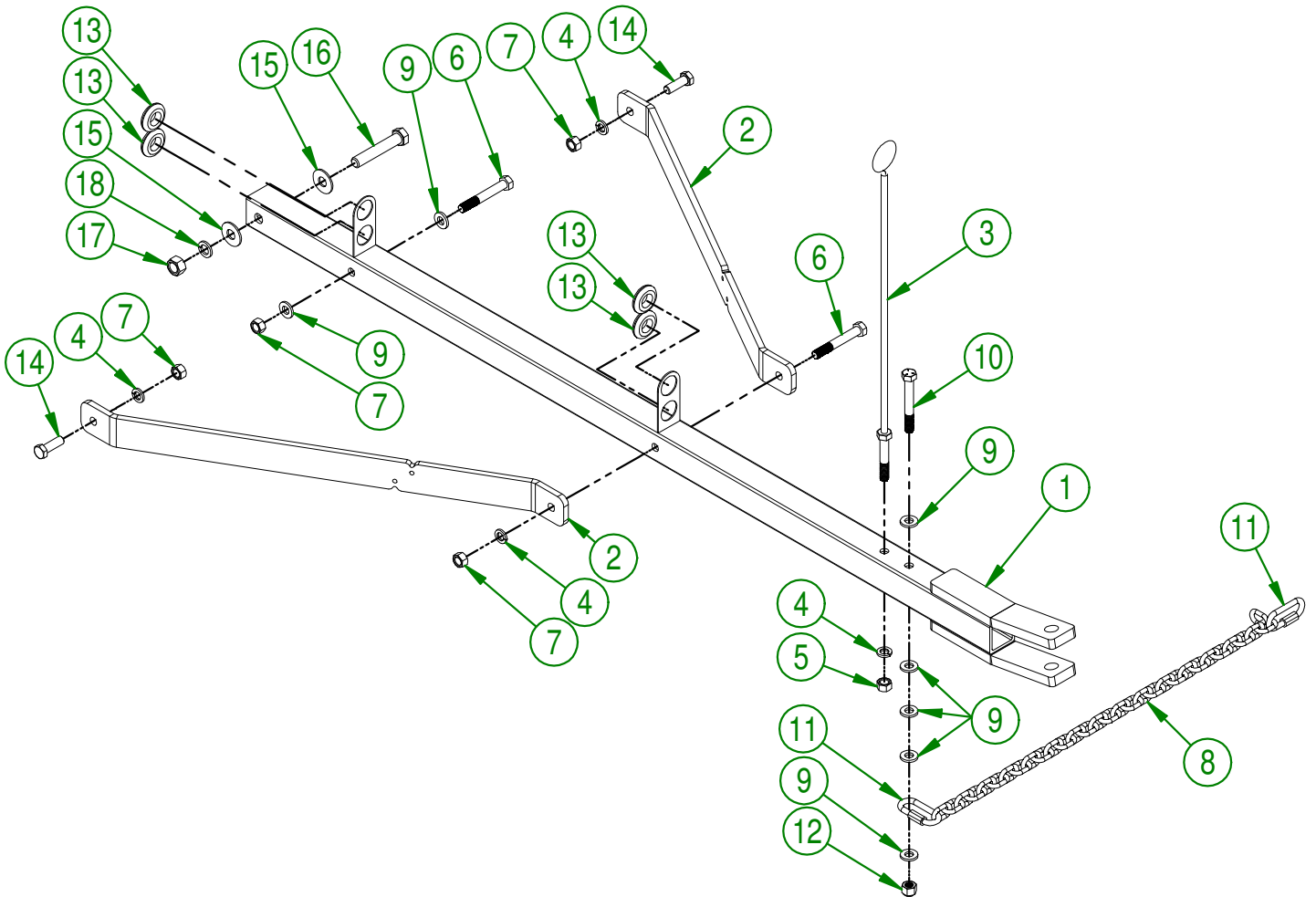

AGRIMETAL
HITCH ASSY.

CREATION : 12/04/18
REVISION : 17/04/18

ASSEMBLY : **21-55-0100**

AUTHOR : F.HÉLIE Page 10 de 12

#	PART #	Qty	TITLE
1	NCI3-30-0237	1	PLASTIC TUBE FOR OPERATOR'S MANUAL
2	21-98-0514	1	OPERATION MANUAL FAIRWAY AERATOR USER'S MOD.
3	NC02-41-0012	2	T METAL HEX. TAPPING SCREW 12 X 1"
4	NC02-25-0007	2	WASHER ZINC 0.281 = 9/32

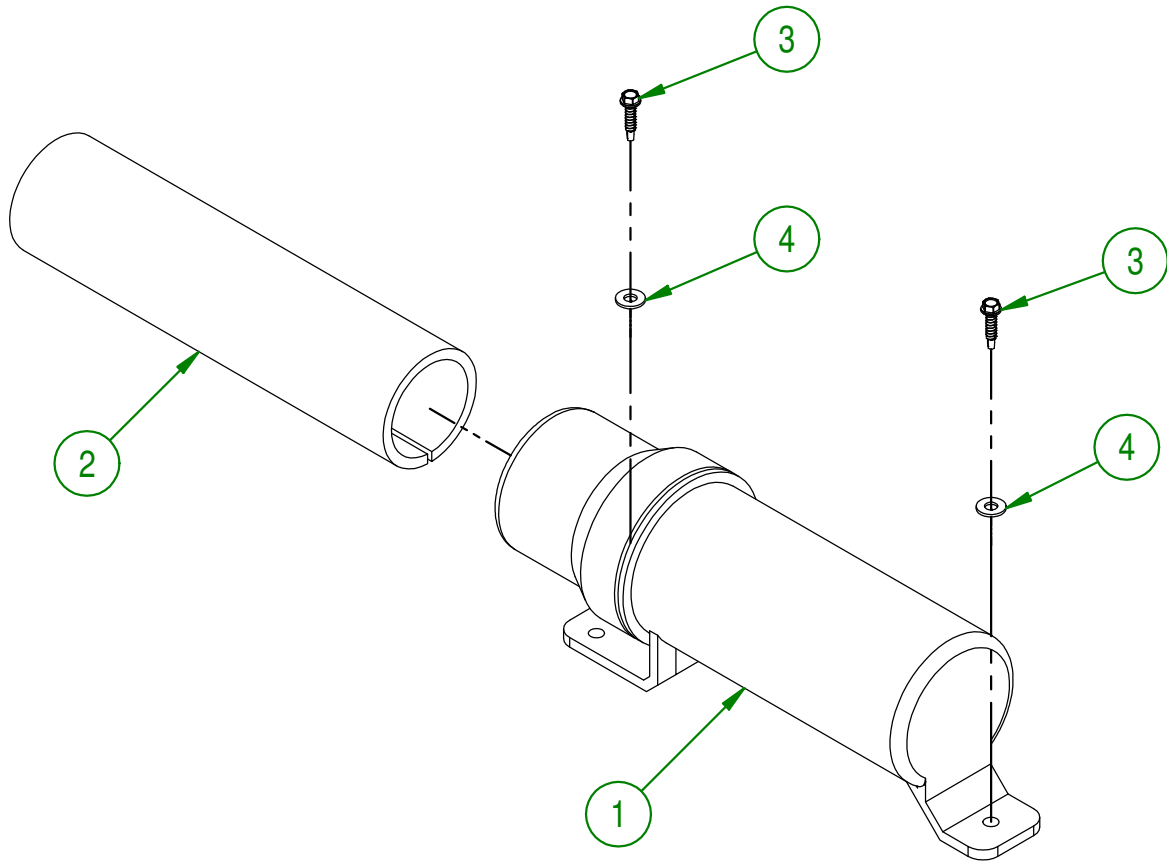

AGRIMETAL	
OPERATION MANUAL ROUND TUBE & BOLTS GROUP.	
CREATION : 12/04/18	ASSEMBLY : 21-57-0239
REVISION : 12/04/18	AUTHOR : J.KABWE Page 11 de 12

#	PART #	Qty	TITLE
1	NCI3-33-0024	6	STICKER GREASE HERE
2	NCI3-33-0002	2	STICKER AGRIMETAL
3	NCI3-33-0279	2	STICKER WARNING
4	NCI3-33-0183	1	STICKER CAUTION OPERATION MANUAL
5	25-55-0710	1	SERIAL NUMBER PLATE
6	NCI3-33-0035	2	STICKER AGRIMETAL

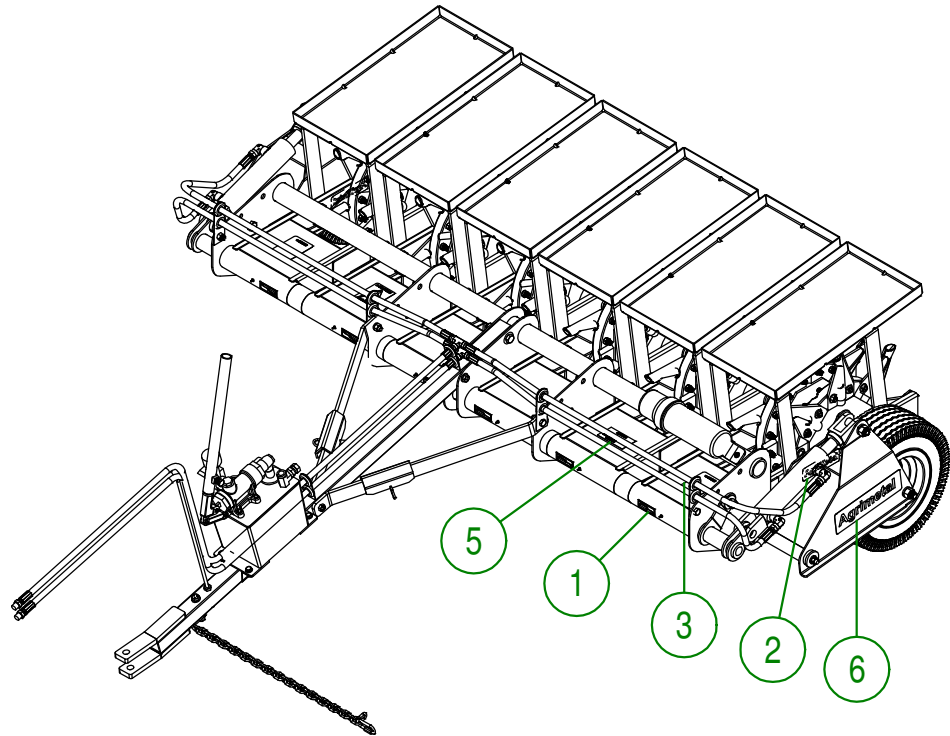
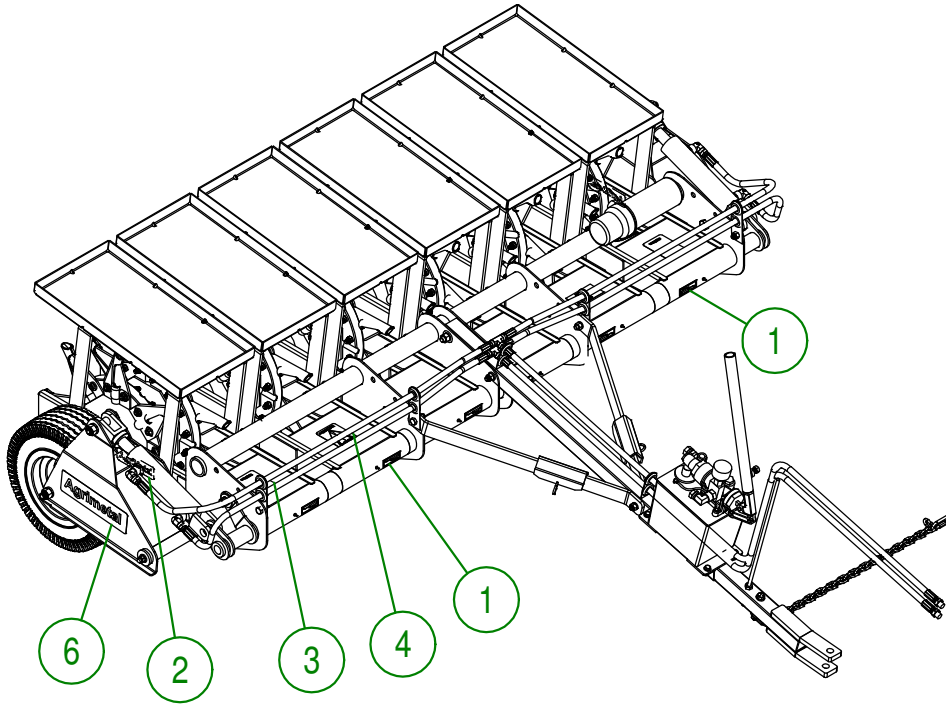

AGRIMETAL	
FAIRWAY AERATOR (F.A. 720)	
CREATION : 17/04/18	ASSEMBLY : 21-99-0011
REVISION : 17/04/18	AUTHOR : J.KABWE Page 12 de 12