

AgriMetal

PART LIST

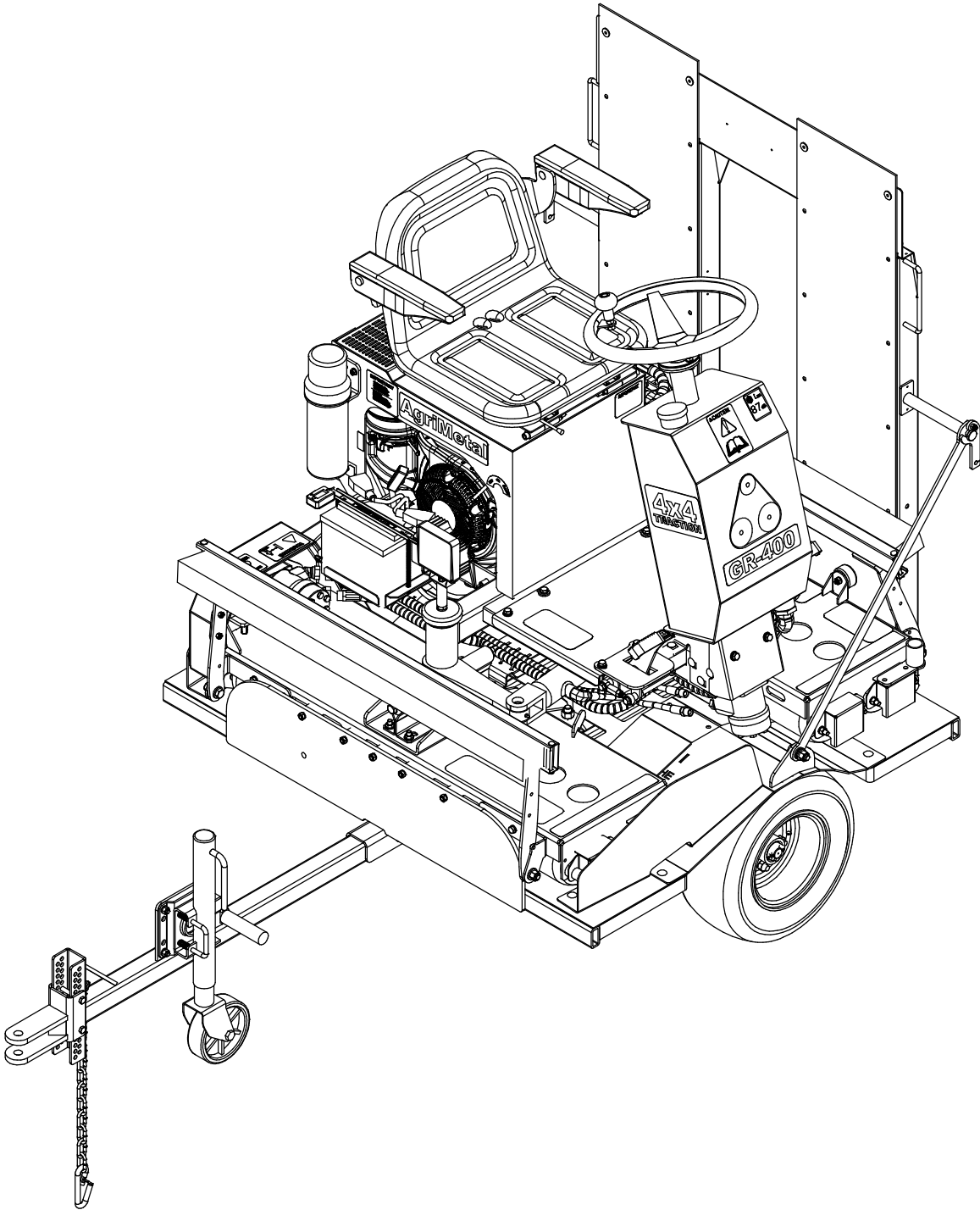

GR 400-G (14HP KOHLER)

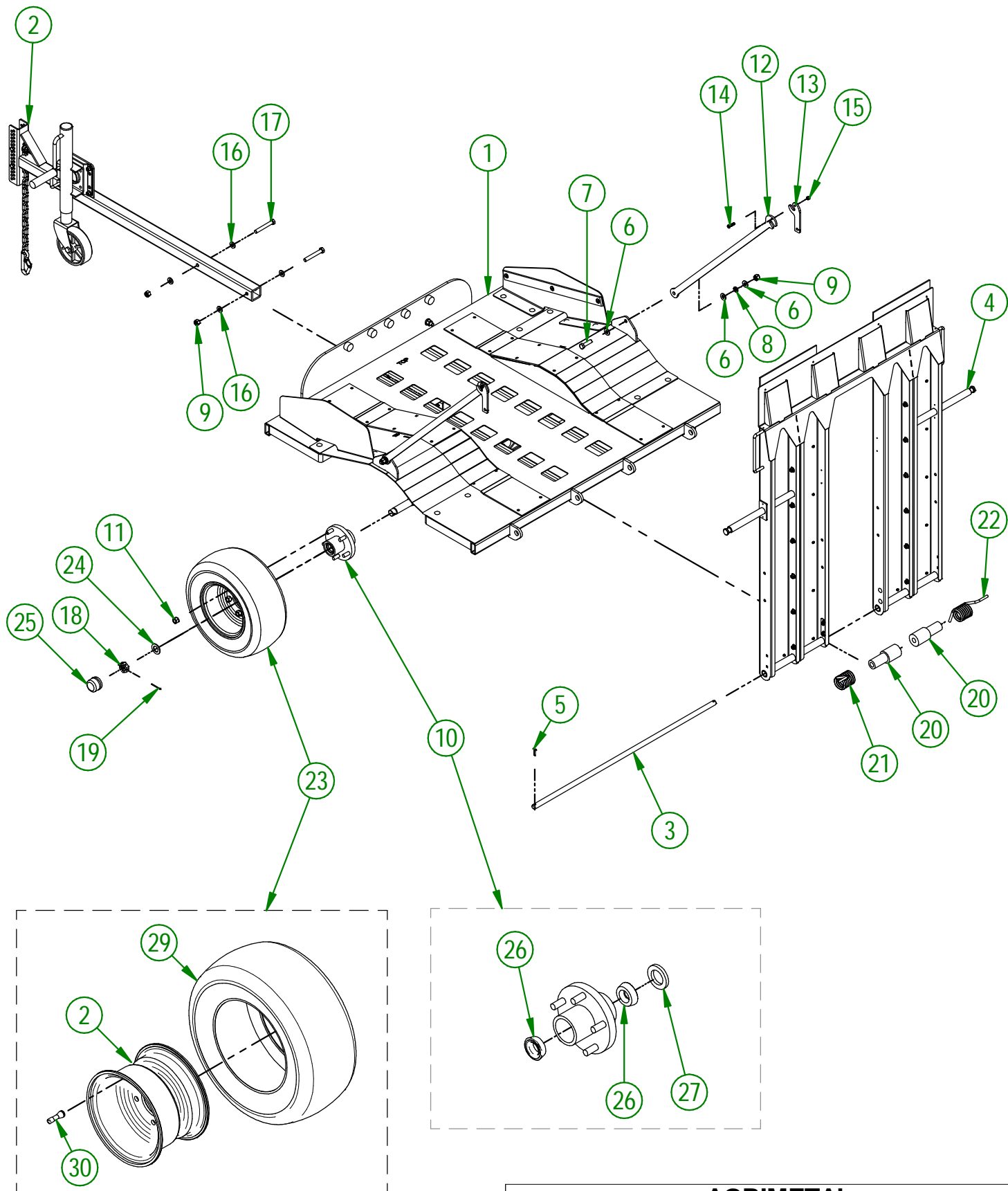

AGRIMETAL	
TRAILER (2 WHEELS)	
CREATION : 08/02/24	ASSEMBLY : 39-55-0523
REVISION : 02/12/24	AUTHOR : D. CHASSÉ

39-55-0523

#	PART#	QTY	TITLE
1	39-57-0524	1	TRAILER
2	39-55-0314	1	DRAWBAR GROUPING
3	39-13-0640	1	PIVOT RAMP
4	39-55-0812	1	RAMP
5	NC01-69-0159	2	COTTER PIN ZINC 3/16 X 1 1/2"
6	NC02-25-0011	6	WASHER SAE ZINC 17/32 ID
7	NC01-17-0250	2	HEX. BOLT GR2 ZINC 1/2-13 X 1 3/4"
8	NC02-32-0014	2	LOCK WASHER ZINC 1/2"
9	NC01-96-0014	5	NYLON-INSERT LOCKNUT ZINC 1/2-13
10	NC14-70-0643	2	HUB
11	NC02-12-0005	10	HEX. NUT ZINC 1/2-20
12	39-04-0441	2	RAMP LOCK
13	39-04-0360	2	DOOR LOCK
14	NC01-29-0006	2	HEX. BOLT GR5 NF ZINC 1/4-28 X 1 1/2
15	NC01-97-0004	2	NYLON-INSERT LOCKNUT ZINC 1/4-28
16	01-01-0925	5	WASHER
17	NC01-17-0257	3	HEX. BOLT GR2 ZINC 1/2-13 X 3 1/2"
18	NC14-70-0310	2	SLOTTED NUT 1-14
19	NC14-70-0311	2	COTTER PIN ZINC 5/32" X 2"
20	39-42-0125	2	SPRING BUSHING
21	NC13-85-0060	1	TRAILER RAMP SPRING
22	NC13-85-0059	1	TRAILER RAMP SPRING
23	NC14-70-0644	2	Wheels GR400
24	NC14-70-0605	2	WASHER
25	NC14-70-0092	2	DUST GUARD

NC14-70-0643

#	PART#	QTY	TITLE
26	NC14-70-0093	2	EXTERIOR BEARING
27	NC14-70-0324	1	SEAL 1.219" X 1.980"

NC14-70-0644

#	PART#	QTY	TITLE
28	NC14-70-0645	1	TIRE RIM GR400
29	NC14-70-0646	1	TIRE GR400
30	NC14-70-0659	1	VALVE FOR NC14-70-0657

#	PART #	Qty	TITLE
1	39-50-0802	1	GR 400 TRAILER
2	NC01-78-0300	24	RIVETS AC. AV. SUPR. TI. AC. .187 X .515 CAP. RIVET .270
3	39-42-0049	2	TRAILER RUBBER
4	NC13-15-0034	5	RUBBER ABSORBER
5	NC02-32-0011	5	LOCK WASHER ZINC 5/16"
6	NC02-07-0017	5	HEX. NUT 5/16-18
7	NC01-04-0107	20	CARR. BOLT GR2 ZINC 3/8-16 X 3/4"
8	NC02-14-0019	20	FLANGE NUT HEX. NC 3/8-16 GR. B
9	39-50-0607	1	LEFT WHEEL FENDER
10	39-50-0602	1	RIGHT WHEEL FENDER
11	39-01-0351	1	RIGHT POSITIONING GUIDE
12	39-42-0190	1	SLIDER
13	NC02-48-0020	3	SOCKET HEAD SCREW 6 P.C. 5/16-20 X 3/4"
14	NC02-22-0008	3	WASHER ZINC 5/16"
15	NC01-93-0010	3	LOCK NUT ZINC 5/16-18
16	39-01-0346	1	LEFT POSITIONING GUIDE

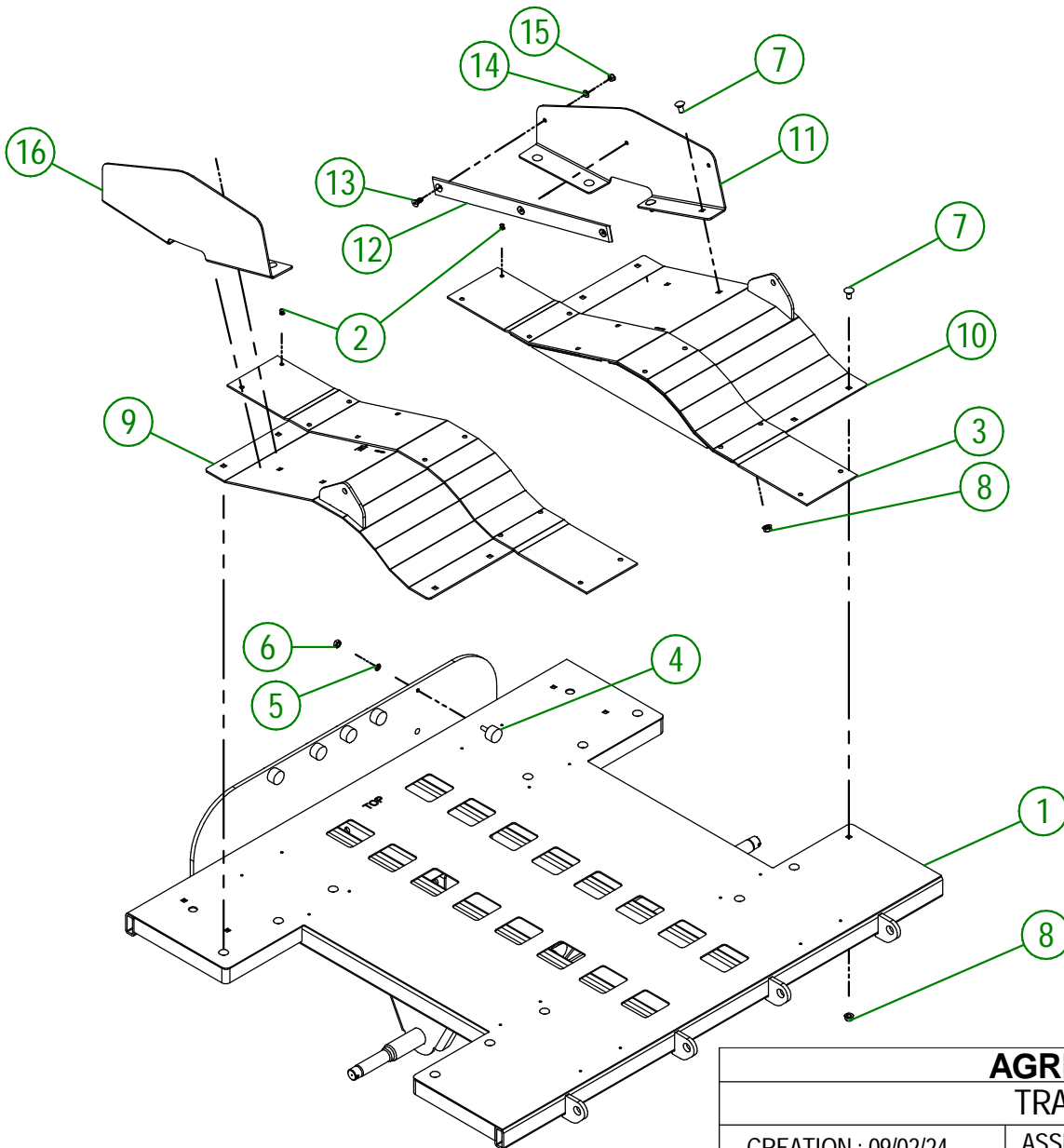

AGRIMETAL
TRAILER

CREATION : 09/02/24
REVISION : 09/02/24

ASSEMBLY : **39-57-0524**
AUTHOR : D. CHASSÉ

#	PART #	Qty	TITLE
1	39-50-0327	1	DRAWBAR
2	23-50-0045	1	HITCH HAND
3	NC13-80-0290	1	2" HITCH BALL COUPLER
4	NC02-25-0011	2	WASHER SAE ZINC 17/32 ID
5	NC01-93-0014	2	LOCK NUT ZINC 1/2-13
6	NC01-25-0257	2	HEX. BOLT GR5 ZINC 1/2-13 X 3 1/2"
7	23-09-0100	1	HITCH SPACER
8	NC02-22-0012	2	WASHER ZINC 1/2 BOLT = 9/16"Ø X 1 3/8" OD
9	NC01-17-0123	2	HEX. BOLT GR2 ZINC 3/8-16 X 3 1/4"
10	NC02-32-0012	6	LOCK WASHER ZINC 3/8"
11	NC02-07-0018	6	HEX. NUT ZINC 3/8-16
12	NC01-17-0116	1	HEX. BOLT GR2 ZINC 3/8-16 X 1 1/2"
13	NC02-22-1010	4	3/8" ZINC PLATED WASHER
14	55-41-0000	1	SAFETY CHAIN
15	NC01-96-0011	1	NYLON NUT 3/8-16
16	39-55-0330	1	ADJUSTABLE WHEEL CRUTCH
17	NC01-04-0109	4	CARR. BOLT GR2 ZINC 3/8-16 X 1"

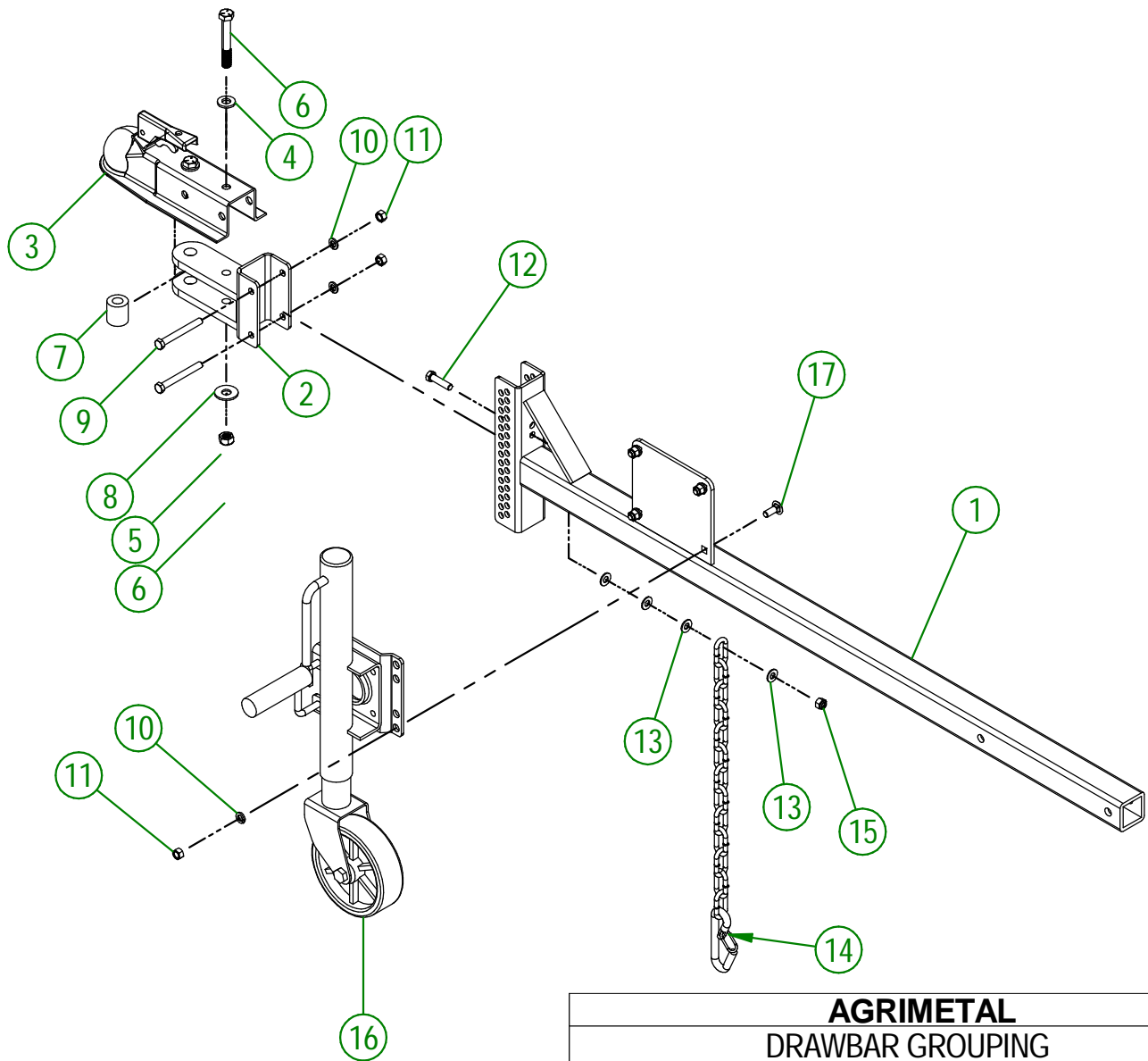

AGRIMETAL
DRAWBAR GROUPING

CREATION : 07/01/21
REVISION : 06/11/24

ASSEMBLY : **39-55-0314**
AUTHOR : J. Houle

39-55-0812

#	PART #	Qty	TITLE
1	39-50-0812	1	TRAILER RAMP
2	39-42-0031	2	RAMP RUBBER
3	NC01-78-0300	24	RIVETS AC. AV. SUPR. TI. AC. .187 X .515 CAP. RIVET .270
4	NC01-78-0405	4	STEEL BLIND POP RIVET STEEL MANDREL 0.187 X 0.690
5	39-01-0170	2	TRAILER RAMP REINFORCEMENT
6	NC01-04-0055	4	CARR. BOLT GR2 ZINC 5/16-18 X 5/8"
7	NC02-14-0006	4	HEX. NUT SPECIAL FLANGET NC 5/16-18 B GRADE
8	16-01-2720	4	WASHER 13/16" DIA. X 13/64"

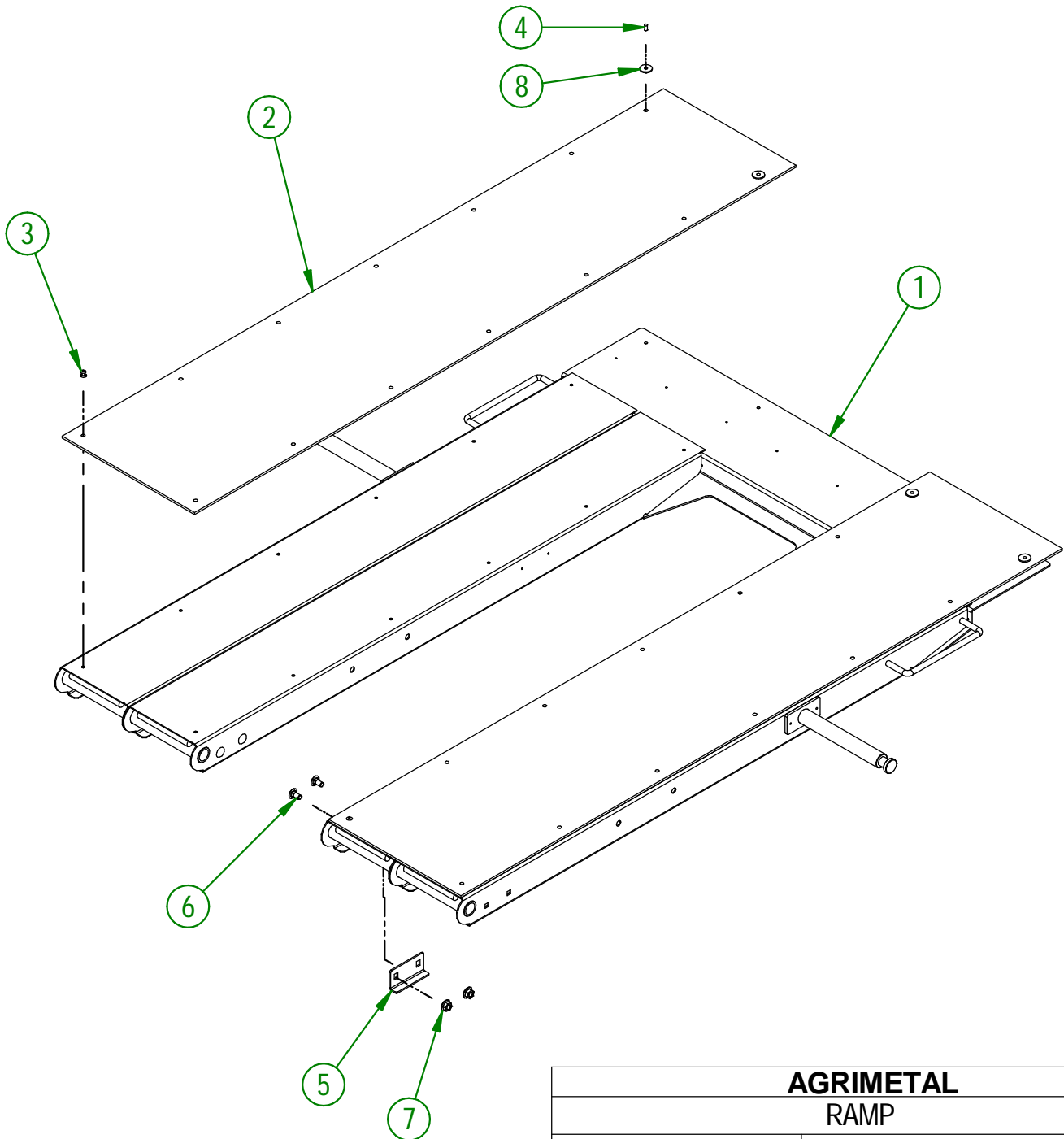

AGRIMETAL
RAMP

CREATION : 07/01/21
REVISION : 24/08/23

ASSEMBLY : **39-55-0812**
AUTHOR : J. Houle

#	PART #	Qty	TITLE
1	39-50-0503	1	FRAME
2	39-57-0125	1	FOOTBOARD "STICKER INCLUDED"
3	NC13-15-0034	2	RUBBER ABSORBER
4	39-50-0020	1	OIL FILTER HOLDER
5	01-01-2485	6	FLAT WASHER 14 GA X 13/16"OD X 25/64" ID
6	NC02-32-0012	8	LOCK WASHER ZINC 3/8"
7	NC01-17-0112	2	HEX. BOLT GR2 ZINC 3/8-16 X 3/4"
8	NC01-17-0114	4	HEX. BOLT GR2 ZINC 3/8-16 X 1"
9	NC02-32-0011	4	LOCK WASHER ZINC 5/16"
10	NC02-07-0017	2	HEX. NUT 5/16-18
11	NC01-17-0060	2	HEX. BOLT GR2 ZINC 5/16-18 X 1"
12	NC01-04-0109	2	CARR. BOLT GR2 ZINC 3/8-16 X 1"
13	NC02-07-0018	2	HEX. NUT ZINC 3/8-16
14	39-04-0186	1	STOPPER PLATE FOR PEDAL (RIGHT)
15	39-04-0188	1	STOPPER PLATE FOR PEDAL (LEFT)
16	NC13-25-0378	2	WHITE METAL CONNECTOR
17	NC13-15-0014	2	RUBBER WIRE WASHER

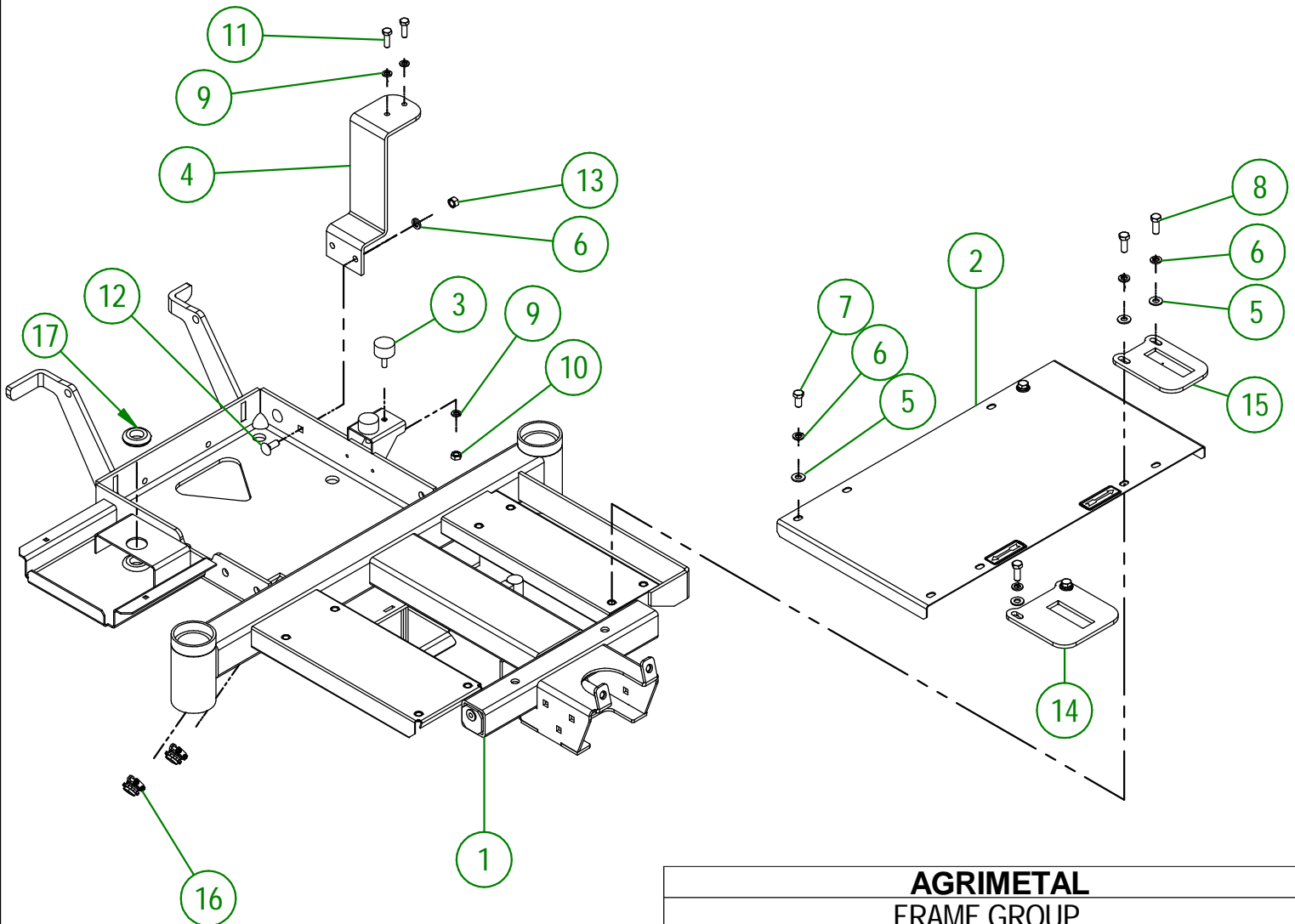

AGRIMETAL
FRAME GROUP

CREATION : 12/03/24
REVISION : 12/03/24

ASSEMBLY : **39-57-0503**
AUTHOR : J. Houle

#	PART #	Qty	TITLE
1	39-55-0621	1	RIGHT FRONT ROLLER
2	39-42-0703	1	PIVOTING BLOCK
3	39-09-1207	1	BUSHING
4	NC02-32-0017	1	LOCK WASHER ZINC 3/4"
5	NC02-11-0023	1	NUT 3/4-16
6	NC01-37-0484	1	HEX BOLT. GR8 NF ZINC 3/4-16 X 7 1/2"

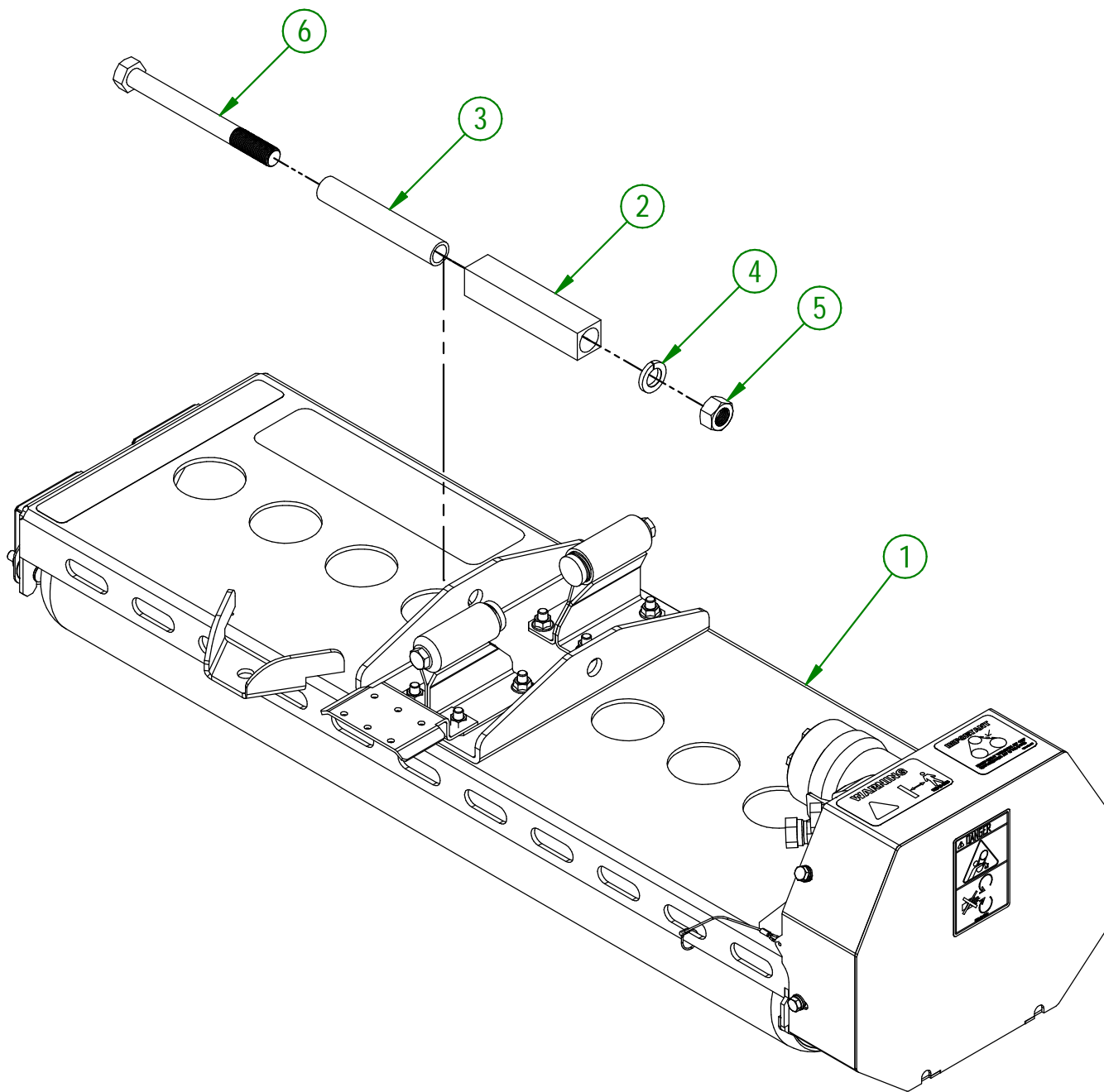

AGRIMETAL	
RIGHT ROLLER GROUP	
CREATION : 01/02/24	ASSEMBLY : 39-57-0604
REVISION : 01/02/24	AUTHOR : D. CHASSÉ

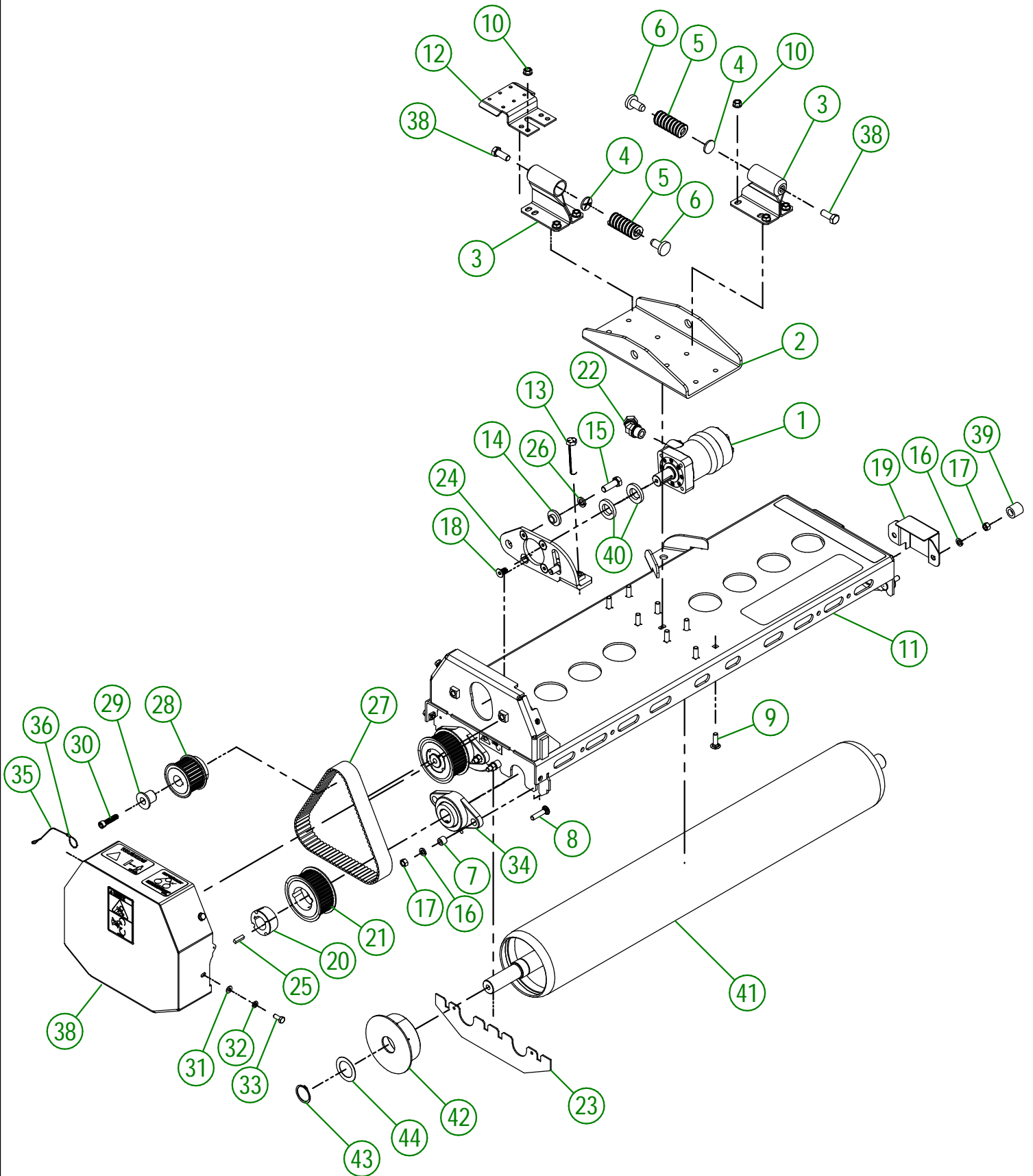

AGRIMETAL

RIGHT FRONT ROLLER

CREATION : 02/02/24
 REVISION : 29/10/24

ASSEMBLY : **39-55-0621**
 AUTHOR : D. CHASSÉ

39-55-0621

#	PART#	QTY	TITLE
1	NC14-45-0041	1	100cc HYDRAULIC MOTOR
2	39-04-0227	1	ROLLER SUPPORT
3	39-50-0045	2	SPRING GUIDE
4	39-01-1000	2	SPRING GUIDE WASHER
5	NC13-86-0159	2	RED SPRING I 1/4"OD X 5/8"ID X 2" LG
6	39-42-0100	2	SPRING TIP
7	01-09-0000	8	BEARING RACE (UCFL205-16)
8	NC01-04-0111	8	CARR. BOLT GR2 ZINC 3/8-16 X I 1/2"
9	NC01-04-0110	8	CARR. BOLT GR2 ZINC 3/8-16 X I 1/4"
10	NC02-14-0019	8	FLANGE NUT HEX. NC 3/8-16 GR. B
11	39-57-0182	1	ROLLER HOUSING FRONT RIGHT
12	39-01-1051	1	HYDRAULIC HOSE SUPPORT
13	NC01-25-0566	1	FULL THREAD HEX BOLT GR5 ZINC 1/2-13 X 3"
14	39-13-0060	2	GUIDE WASHER
15	NC01-25-0249	2	HEX. BOLT GR5 ZINC 1/2-13 X I 1/2" LG
16	NC02-32-0012	8	LOCK WASHER ZINC 3/8"
17	NC02-07-0018	8	HEX. NUT ZINC 3/8-16
18	NC02-48-0031	4	SOCKET HEAD CAP SCREW 3/8-16 X 3/4"
19	39-01-0131	2	BEARING GUARD
20	NC14-60-0015	2	TAPER LOCK I610 X I 1/4"
21	NC14-60-0014	2	38-C8M-36 STEEL PULLEY
22	NC13-45-0046	2	45°-7/8-14 MALE O RING X 1/2 FEM.TOUR.NPT PT
23	39-01-0366	1	BELT GUARD PLATE
24	39-50-0165	1	BELT TENSIONER
25	NC01-65-0095	2	SQUARE KEY 1/4" X 1"
26	NC02-32-0014	2	LOCK WASHER ZINC 1/2"
27	NC14-25-5381	1	SYNCHROCHAIN POLY BELT
28	NC14-60-0013	1	38-C8M-36 STEEL PULLEY
29	39-13-0300	1	PULLEY RETAINER
30	NC02-50-0033	1	SOCKET HEAD SCREW 3/8-16 X I 1/2"
31	NC02-22-0008	4	WASHER ZINC 5/16"
32	NC02-32-0011	4	LOCK WASHER ZINC 5/16"
33	NC01-17-0058	4	HEX. BOLT GR2 ZINC 5/16-18 X 3/4" LG
34	NC14-75-0114	4	FLANGE PILLOW BLOCK BEARING UCFL206-20 Ø I 1/4"
35	39-41-0000	1	BELT GUARD CABLE
36	NC01-64-0005	2	OVAL SLEEVE (ALUMINUM)
37	39-57-0062	1	BELT GUARD "STICKER INCL."
38	NC01-17-0248	2	HEX. BOLT GR2 ZINC 1/2-13 X I 1/4"
39	39-42-0111	1	ROLLER NUT CAP
40	39-04-0660	2	PULLEY SPACER
41	39-50-0597	2	ROLLER
42	NC17-46-0032	4	ROLLER CAP
43	NC01-64-0022	4	QD BUSHING
44	NC02-19-5008	4	SPACING WASHER 1/32" X I 1/2" ID X 2 1/4" OD

#	PART #	Qty	TITLE
1	39-55-0626	1	LEFT FRONT ROLLER
2	39-42-0703	1	PIVOTING BLOCK
3	39-09-1207	1	BUSHING
4	39-50-0573	1	LEFT PIVOT TRAILER
5	39-21-0000	1	STEERING PLATE SHAFT COVER
6	NC02-32-0014	1	LOCK WASHER ZINC 1/2"
7	NC01-17-0249	1	HEX. BOLT GR2 ZINC 1/2-13 X 1 1/2"
8	NC01-37-0484	1	HEX BOLT. GR8 NF ZINC 3/4-16 X 7 1/2"
9	NC02-32-0017	1	LOCK WASHER ZINC 3/4"
10	NC02-11-0023	1	NUT 3/4-16
11	NC14-75-0091	2	6206 ZZ BEARING

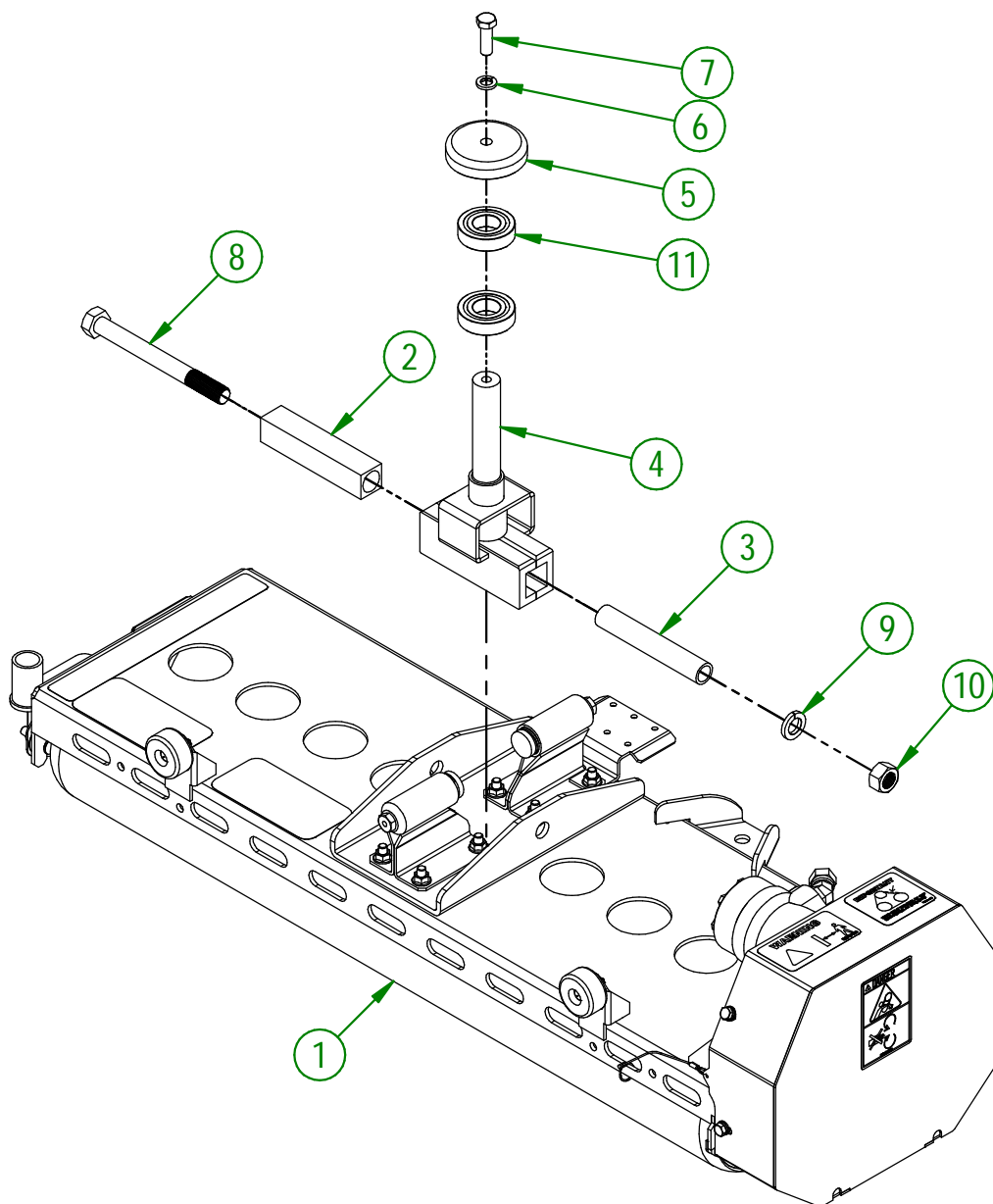

AGRIMETAL	
LEFT ROLLER GROUP	
CREATION : 06/02/24	ASSEMBLY : 39-57-0609
REVISION : 06/02/24	AUTHOR : D. CHASSÉ

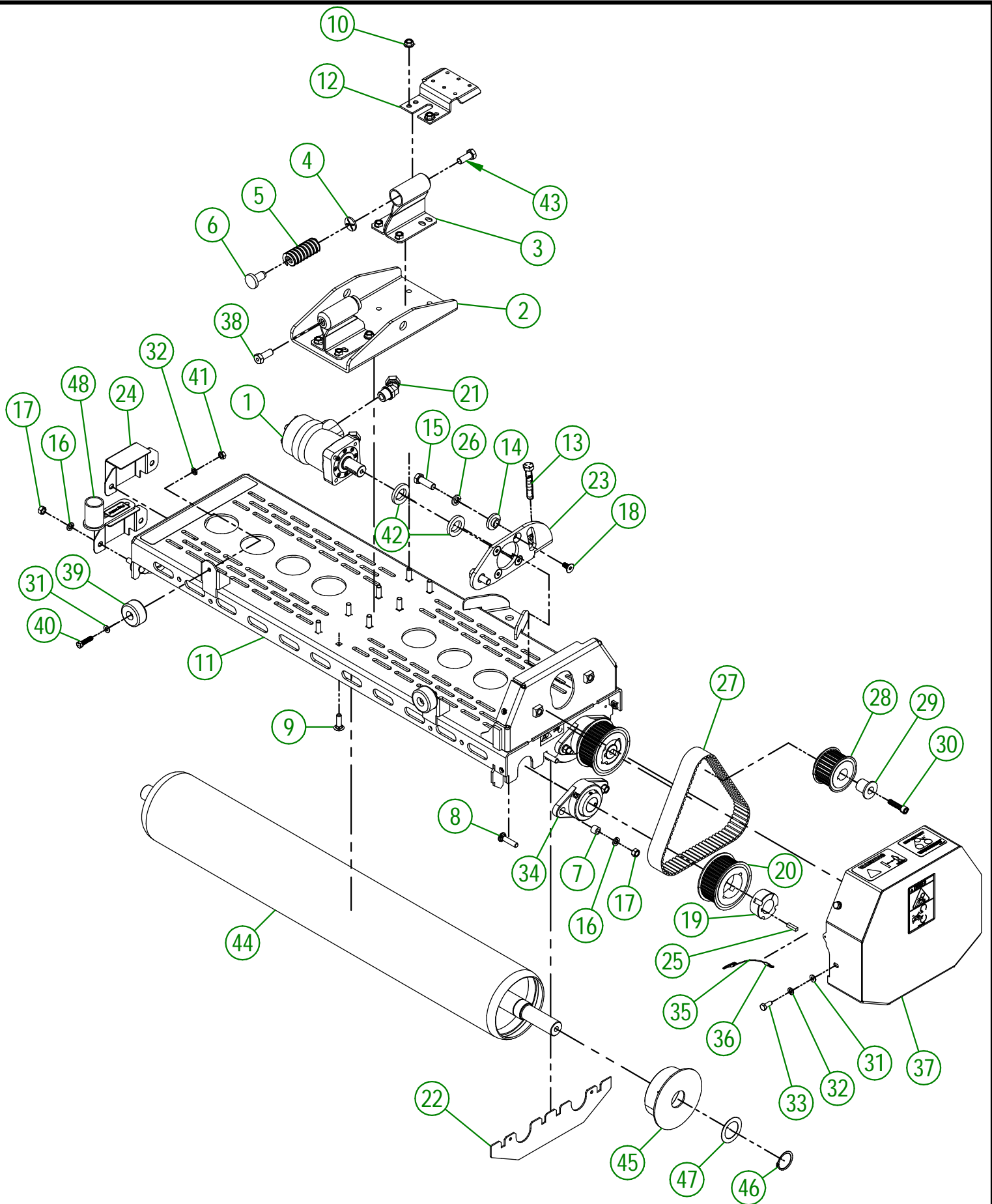

AGRIMETAL
LEFT FRONT ROLLER

CREATION : 06/02/24
REVISION : 02/07/25

ASSEMBLY : **39-55-0626**
AUTHOR : D. CHASSÉ

#	PART #	Qty	TITLE
1	NC14-45-0041	1	100cc HYDRAULIC MOTOR
2	39-04-0227	1	ROLLER SUPPORT
3	39-50-0045	2	SPRING GUIDE
4	39-01-1000	2	SPRING GUIDE WASHER
5	NC13-86-0159	2	RED SPRING I 1/4"OD X 5/8"ID X 2" LG
6	39-42-0100	2	SPRING TIP
7	01-09-0000	8	BEARING RACE (UCFL205-16)
8	NC01-04-0111	8	CARR. BOLT GR2 ZINC 3/8-16 X I 1/2"
9	NC01-04-0110	8	CARR. BOLT GR2 ZINC 3/8-16 X I 1/4"
10	NC02-14-0019	8	FLANGE NUT HEX. NC 3/8-16 GR. B
11	39-57-0172	1	ROLLER HOUSING (LEFT)
12	39-01-1051	1	HYDRAULIC HOSE SUPPORT
13	NC01-25-0566	1	FULL THREAD HEX BOLT GR5 ZINC 1/2-13 X 3"
14	39-13-0060	2	GUIDE WASHER
15	NC01-25-0249	2	HEX. BOLT GR5 ZINC 1/2-13 X I 1/2" LG
16	NC02-32-0012	8	LOCK WASHER ZINC 3/8"
17	NC02-07-0018	8	HEX. NUT ZINC 3/8-16
18	NC02-48-0031	4	SOCKET HEAD CAP SCREW 3/8-16 X 3/4"
19	NC14-60-0015	2	TAPER LOCK 1610 X I 1/4"
20	NC14-60-0014	2	38-C8M-36 STEEL PULLEY
21	NC13-45-0046	2	45°-7/8-14 MALE O RING X 1/2 FEM.TOUR.NPT PT
22	39-01-0366	1	BELT GUARD PLATE
23	39-50-0165	1	BELT TENSIONER
24	39-01-0131	1	BEARING GUARD
25	NC01-65-0095	2	SQUARE KEY 1/4" X 1"
26	NC02-32-0014	2	LOCK WASHER ZINC 1/2"
27	NC14-25-5381	1	SYNCHROCHAIN POLY BELT
28	NC14-60-0013	1	38-C8M-36 STEEL PULLEY
29	39-13-0300	1	PULLEY RETAINER
30	NC02-50-0033	1	SOCKET HEAD SCREW 3/8-16 X I 1/2"
31	NC02-22-0008	6	WASHER ZINC 5/16"
32	NC02-32-0011	6	LOCK WASHER ZINC 5/16"
33	NC01-17-0058	4	HEX. BOLT GR2 ZINC 5/16-18 X 3/4" LG
34	NC14-75-0114	4	FLANGE PILLOW BLOCK BEARING UCFL206-20 Ø I 1/4"
35	39-41-0000	1	BELT GUARD CABLE
36	NC01-64-0005	2	OVAL SLEEVE (ALUMINUM)
37	39-57-0062	1	BELT GUARD "STICKER INCL."
38	39-30-9960	1	LEFT LIGHT HOLDER
39	39-42-0165	2	RETAINER
40	NC01-25-0061	2	HEX BOLT ZINC 5/6-18 X I 1/4"
41	NC02-07-0017	2	HEX. NUT 5/16-18
42	39-04-0660	2	PULLEY SPACER
43	NC01-17-0248	1	HEX. BOLT GR2 ZINC 1/2-13 X I 1/4"
44	39-50-0597	2	ROLLER
45	NC17-46-0032	4	ROLLER CAP
46	NC01-64-0022	4	QD BUSHING
47	NC02-18-0095	4	SPACING WASHER 1/32" X I 1/2" ID X 2 1/4" OD
48	39-57-0655	1	BEARING GUARD

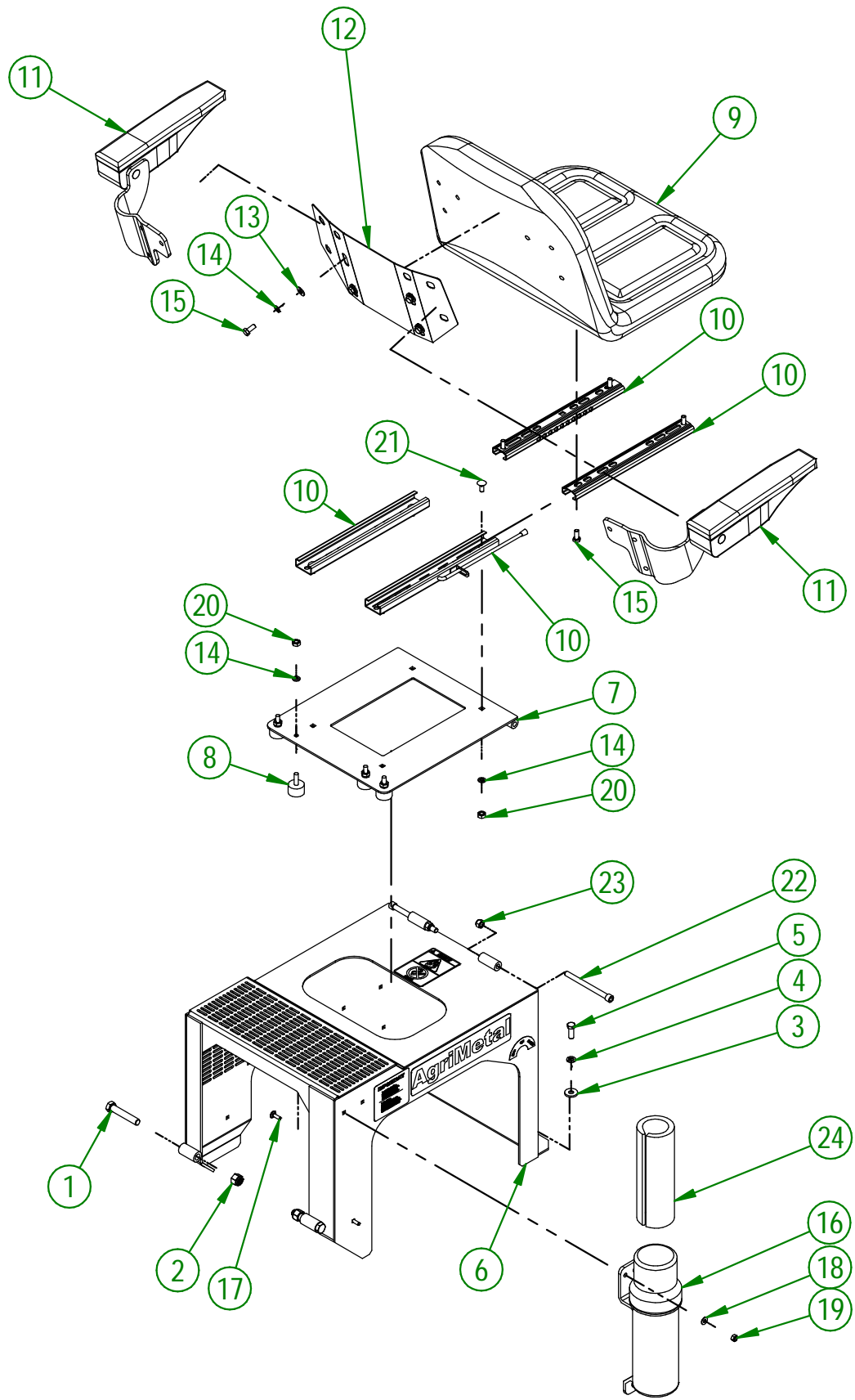

AGRIMETAL	
ENGINE COVER GROUP	
CREATION : 12/03/24	ASSEMBLY : 39-57-0380
REVISION : 12/03/24	AUTHOR : D. CHASSÉ

39-57-0380

#	PART #	Qty	TITLE
1	NC01-17-0254	2	HEX. BOLT GR2 ZINC 1/2-13 X 2 1/2"
2	NC01-96-0014	2	NYLON-INSERT LOCKNUT ZINC 1/2-13
3	21-01-0950	2	FLAT WASHER 10GA 1.005" DIA X 25/64"
4	NC02-32-0012	2	LOCK WASHER ZINC 3/8"
5	NC01-17-0114	2	HEX. BOLT GR2 ZINC 3/8-16 X 1"
6	39-57-0012	1	ENGINE COVER
7	39-50-0115	1	SEAT FOLDER HOLDER
8	NC13-15-0034	4	RUBBER ABSORBER
9	NC13-80-0200	1	SEAT
10	NC13-80-0201	1	SET OF SEAT RAIL
11	NC13-80-0295	1	ARMRESTS
12	39-01-0400	1	BACK REST SEAT REINFORCEMENT
13	01-01-2485	4	FLAT WASHER 14 GA X 13/16"OD X 25/64" ID
14	NC02-32-0011	12	LOCK WASHER ZINC 5/16"
15	NC01-17-0058	8	HEX. BOLT GR2 ZINC 5/16-18 X 3/4" LG
16	NC13-30-0237	1	PLASTIC TUBE FOR OPERATOR'S MANUAL
17	NC01-04-0003	3	CARR. BOLT GR2 ZINC 1/4-20 X 3/4"
18	NC02-25-0007	3	WASHER ZINC 0.281 = 9/32
19	NC01-96-0009	3	NYLON-INSERT LOCKNUT ZINC 1/4-20
20	NC02-07-0017	8	HEX. NUT 5/16-18
21	NC01-04-0056	4	CARR. BOLT 5/16-18 X3/4"
22	NC02-50-0112	2	HEX. BOLT GR2 ZINC 3/8-16 X 4 1/2"
23	NC01-96-0011	2	NYLON NUT 3/8-16
24	39-98-0631	1	OPERATOR'S MANUAL

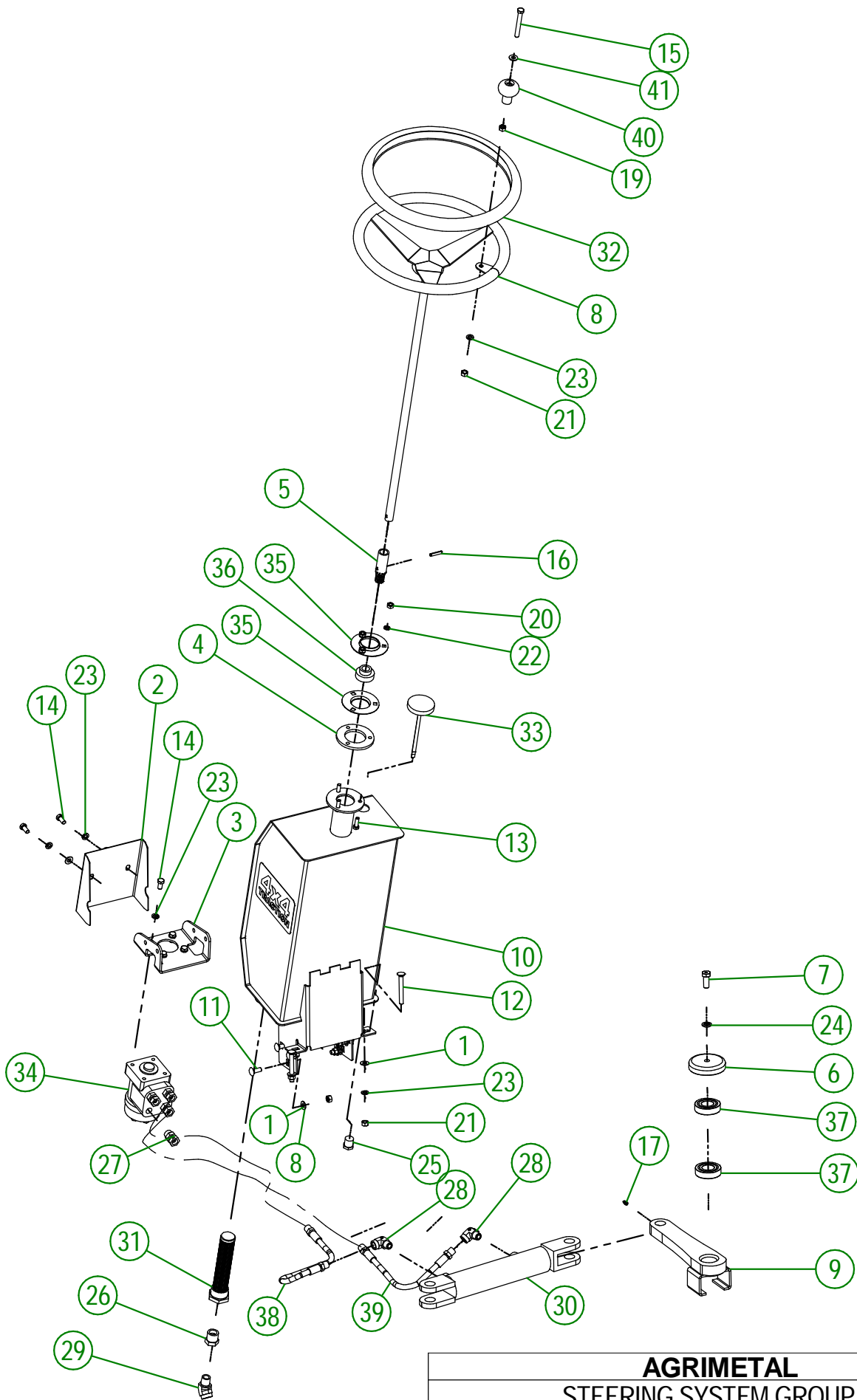

AGRIMETAL
STEERING SYSTEM GROUP

CREATION : 01/02/24
 REVISION : 19/03/25

ASSEMBLY : **39-57-0549**
 AUTHOR : J. Houle

39-57-0549

#	PART #	Qty	TITLE
1	01-01-2485	10	FLAT WASHER 14 GA X 13/16"OD X 25/64" ID
2	39-01-0080	1	STEERING SHAFT GUARD
3	39-04-0195	1	HYDRAULIQUE CONTROL SUPPORT
4	39-04-0275	1	STEERING SHAFT BEARING SUPPORT
5	39-20-0005	1	STEERING SHAFT ADAPTER
6	39-21-0000	1	STEERING PLATE SHAFT COVER
7	39-30-9960	1	LEFT LIGHT HOLDER
8	39-50-0081	1	STEERING WHEEL
9	39-50-0571	1	STEERING PLATE
10	39-57-0143	1	OIL TANK
11	NC01-04-0109	6	CARR. BOLT GR2 ZINC 3/8-16 X 1"
12	NC01-04-0117	2	CARR. BOLT GR2 NC ZINC 3/8-16 X 3"
13	NC01-17-0060	3	HEX. BOLT GR2 ZINC 5/16-18 X 1"
14	NC01-17-0112	6	HEX. BOLT GR2 ZINC 3/8-16 X 3/4"
15	NC01-17-0122	1	HEX. BOLT GR2 ZINC 3/8-16 X 3"
16	NC01-69-0459	1	ZINC SPRING PIN TENDER DIA. 1/4" X 1 1/4"
17	NC01-69-0785	1	STRAIGHT GREASE FITTING 1/4-28
18	NC01-93-0011	6	LOCK NUT 3/8-16
19	NC01-96-0011	1	NYLON NUT 3/8-16
20	NC02-07-0017	3	HEX. NUT 5/16-18
21	NC02-07-0018	3	HEX. NUT ZINC 3/8-16
22	NC02-32-0011	3	LOCK WASHER ZINC 5/16"
23	NC02-32-0012	9	LOCK WASHER ZINC 3/8"
24	NC02-32-0014	1	LOCK WASHER ZINC 1/2"
25	NC13-45-0015	1	HEX. CAP 1/2 NPTF MALE
26	NC13-45-0032	1	STRAIGHT HOSE FITTING 1/2 FEM. NPT X 3/4 MALE NPT
27	NC13-45-0036	4	STRAIGHT REDUCER 3/4-16 MALE SAE8 O RING X 3/8 FEMALE SWIVEL
28	NC13-45-0038	2	ELBOW 90 3/8 FEM. NPT X 3/8 MALE NPT
29	NC13-45-0086	1	ELBOW 45 1/2 FEM. NPT X 1/2 MALE NPT
30	NC13-45-0370	1	HYDRAULIC CYLINDER 6"
31	NC13-45-0381	1	TANK STRAINER
32	NC13-80-0254	1	STEERING WHEEL COVER
33	NC13-80-0311	1	CAP WITH DIPSTICK
34	NC14-45-0151	1	HYDRAULIC STEERING ASSIST
35	NC14-75-0008	2	STEEL BEARING ONLY 3 HOLES F4 3 9/16" OD
36	NC14-75-0014	1	STEEL BEARING SB 204-12 X 3/4" ID
37	NC14-75-0091	2	6206 ZZ BEARING
38	NC17-02-0436	1	HYD. HOSE 3/8 X 13 1/2"OAL 3/8 NPTMALE RIG.X 3/8NPTMALE RIG
39	NC17-02-0437	1	HYD. HOSE 3/8 X 18"OAL 3/8 NPTMALE RIG.X 3/8NPTMALE RIG
40	NC17-46-0018	1	HANDLE KNOB
41	NC17-57-0016	1	FLAT WASHER 14 GA X 13/16"OD X 25/64" ID

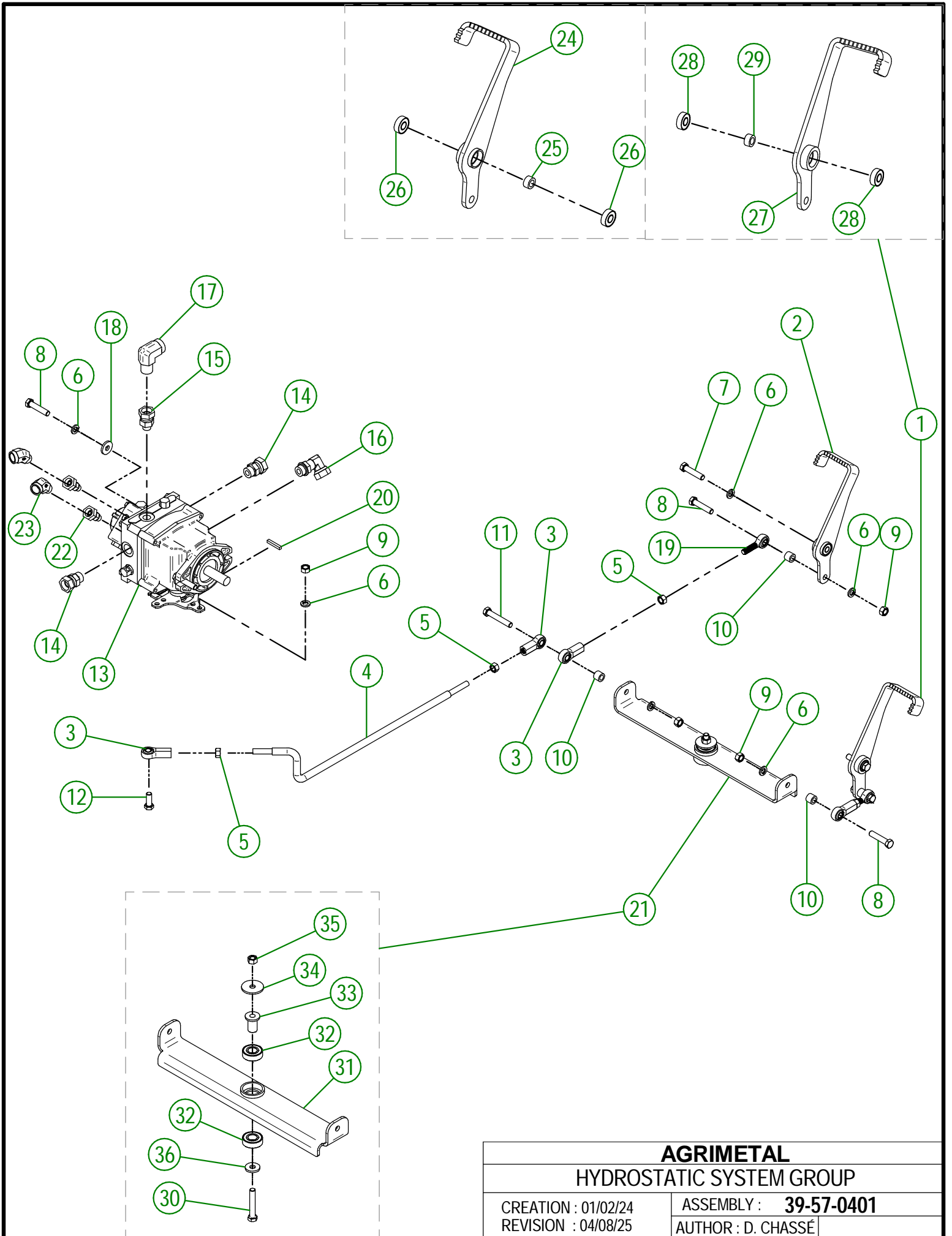

AGRIMETAL	
HYDROSTATIC SYSTEM GROUP	
CREATION : 01/02/24	ASSEMBLY : 39-57-0401
REVISION : 04/08/25	AUTHOR : D. CHASSÉ

39-57-0401

#	PART #	Qty	TITLE
1	39-55-0026	1	RIGHT PEDAL
2	39-55-0021	1	LEFT PEDAL
3	NC01-67-0104	4	INTERNALLY THREADED BALL JOINT ROD ENDS 3/8-24
4	39-13-0401	1	HYDROSTATIC CONTROL ROD
5	NC02-10-0018	4	NUT 3/8-24
6	NC02-32-0012	9	LOCK WASHER ZINC 3/8"
7	NC01-33-0117	2	CARR. BOLT GR8 ZINC 3/8-16 X 1 3/4"
8	NC01-17-0117	5	HEX. BOLT GR2 ZINC 3/8-16 X 1 3/4"
9	NC02-07-0018	5	HEX. NUT ZINC 3/8-16
10	39-09-0050	4	PEDAL SYSTEM BUSHING
11	NC01-17-0119	1	HEX. BOLT GR2 ZINC 3/8-16 X 2 1/4"
12	NC01-17-0114	1	HEX. BOLT GR2 ZINC 3/8-16 X 1"
13	NC14-45-0153	1	HYDROSTATIC MOTOR
14	NC13-45-0106	2	STRAIGHT REDUCER 3/4-16 MALE SAE8 O RING X 1/2 FEMALE
15	NC13-45-0220	1	STRAIGHT 9/16 MALE ORING X 1/2 FEMALE NPT
16	NC13-45-0203	1	ELBOW 90° 3/4 MALE ORING X 1/2 FEMALE NPT
17	NC13-45-0025	1	ELBOW 90° 1/2 FEMALE NPT X 1/2 MALE NPT
18	21-01-0950	2	FLAT WASHER 10GA 1.005" DIA X 25/64"
19	NC01-67-0304	2	BALL JOINTS ROD ENDS 3/8-24
20	01-41-0905	1	SQUARE KEY 3/16" X 1 1/4"TL
21	39-57-0220	1	PEDAL JUNCTION ARM
22	NC13-45-0401	2	STRAIGHT REDUCER 7/16-20 MALE SAE4 O RING X 3/8 FEMALE SWIVEL
23	NC13-45-0085	2	45° ELBOW 3/8" NPT MALE X 3/8" NPT FEMALE

39-55-0021

#	PART #	Qty	TITLE
24	39-50-0111	1	LEFT PEDAL
25	01-09-0005	1	BUSHING
26	NC14-75-0153	2	BALL BEARING R6 2RS 3/8" X 7/8" X 0.281"

39-55-0026

#	PART #	Qty	TITLE
27	39-50-0106	1	RIGHT PEDAL
28	NC14-75-0153	2	BALL BEARING R6 2RS 3/8" X 7/8" X 0.281"
29	01-09-0005	1	BUSHING

39-57-0220

#	PART #	Qty	TITLE
30	NC01-37-0119	1	HEX BOLT GR8 ZINC 3/8-24 X 2 1/4"
31	39-50-0042	1	PEDALS UNION
32	NC14-75-0068	2	BALL BEARING 99502H
33	39-13-0200	1	JONCTION ARM PIVOT
34	01-33-0010	1	WASHER
35	NC01-94-0011	1	LOCK NUT 3/8-24
36	21-01-0950	1	FLAT WASHER 10GA 1.005" DIA X 25/64"

#	PART #	Qty	TITLE
1	26-03-4800	4	WASHER
2	NC13-15-0059	4	YELLOW RUBBER BASE MOUNT
3	01-33-0010	4	WASHER
4	01-01-2485	4	FLAT WASHER 14 GA X 13/16"OD X 25/64" ID
5	NC02-32-0012	8	LOCK WASHER ZINC 3/8"
6	NC02-07-0018	8	HEX. NUT ZINC 3/8-16
7	NC14-05-0029	1	COUPLING (LOVEJOY) CXL100 X 1" ID
8	NC14-05-0030	1	COUPLING (LOVEJOY) RUBBER N100
9	39-46-3500	1	HYDROSTATIC COUPLING HUB
10	39-42-0605	1	GAS THROTTLE EXTENSION
11	NC01-65-0053	2	COLLAR (MH4)
12	39-01-0360	1	MOTOR BASE
13	21-01-0950	4	FLAT WASHER 10GA 1.005" DIA X 25/64"
14	NC01-17-0119	4	HEX. BOLT GR2 ZINC 3/8-16 X 2 1/4"
15	NC01-17-0117	4	HEX. BOLT GR2 ZINC 3/8-16 X 1 3/4"

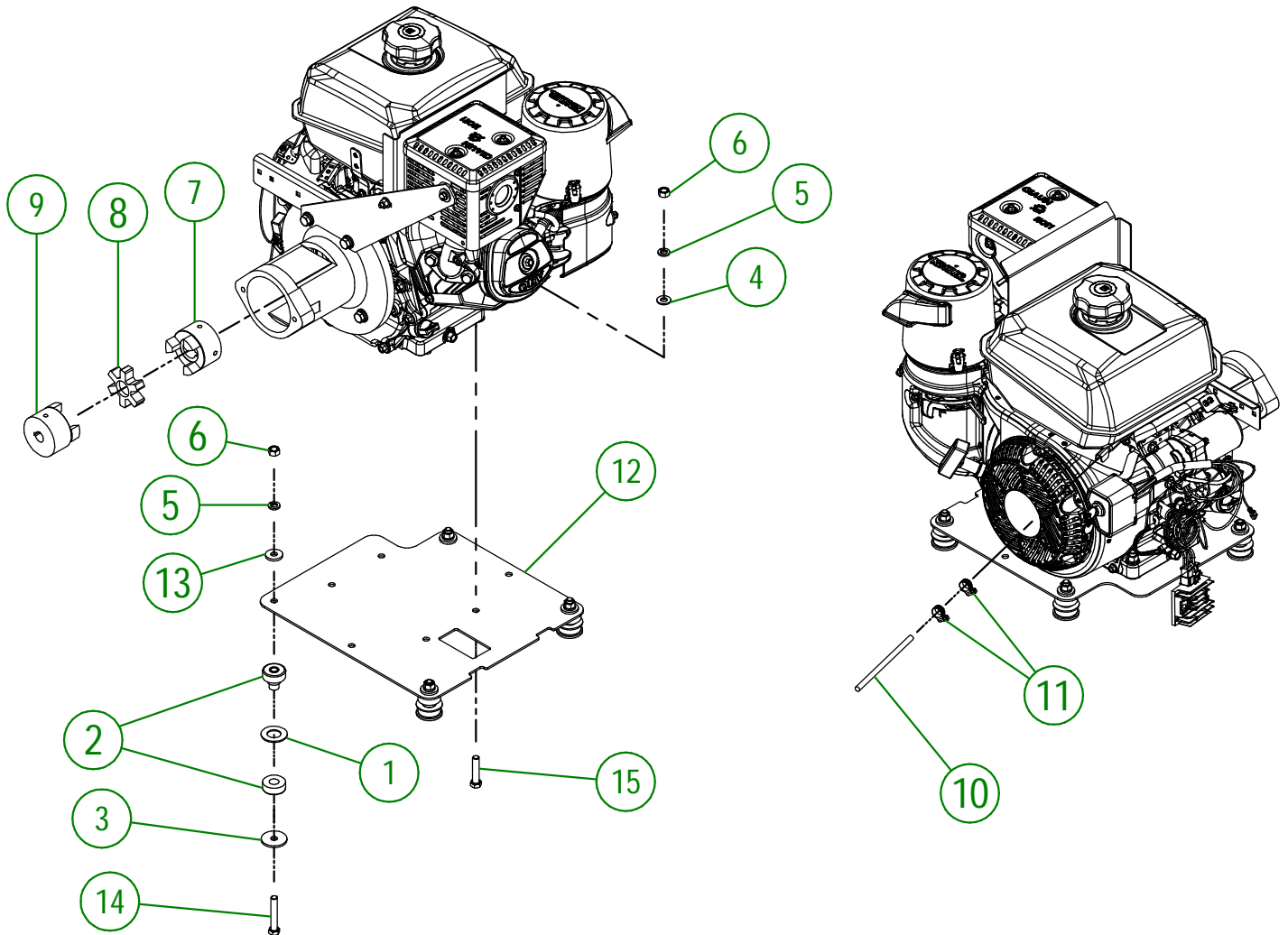

AGRIMETAL
KOHLER MOTOR GROUP

CREATION : 01/03/23
 REVISION : 09/02/24

ASSEMBLY : **39-57-0211**
 AUTHOR : dessin3

#	PART #	Qty	TITLE
1	39-50-0120	1	FUEL ENGINE ADAPTER FOR HYDROSTATIC PUMP
2	01-01-2485	4	FLAT WASHER 14 GA X 13/16"OD X 25/64" ID
3	NC02-32-0012	4	LOCK WASHER ZINC 3/8"
4	NC01-17-0115	2	HEX. BOLT GR2 ZINC 3/8-16 X 1 1/4"
5	NC01-17-0117	2	HEX. BOLT GR2 ZINC 3/8-16 X 1 3/4"
6	39-01-0310	1	MUFFLER HOLDER
7	21-01-0950	4	FLAT WASHER 10GA 1.005" DIA X 25/64"
8	39-01-2405	1	VOLTAGE REGULATOR HOLDER
9	36-01-2430	1	FLAT WASHER 14GA X 17/64" I.D. X 13/16" O.D.
10	NC02-32-0010	1	LOCK WASHER ZINC 1/4"
11	NC01-45-0116	1	METRIC BOLT GR8.8 NC ZINC 6MM X 25 MM
12	26-21-0098	1	MUFFLER HOLDER RING
13	39-03-0005	1	HEAT SHIELD
14	NC01-04-0003	1	CARR. BOLT GR2 ZINC 1/4-20 X 3/4"
15	NC01-04-0056	1	CARR. BOLT 5/16-18 X3/4"
16	NC02-14-0006	1	HEX. NUT SPECIAL FLANGET NC 5/16-18 B GRADE
17	NC01-93-0001	1	HEX. NUT NC ZINC 1/4-20
18	NC02-22-0008	1	WASHER ZINC 5/16"
19	22-22-2600	2	CARRIAGE BOLT SHIM (5/16")

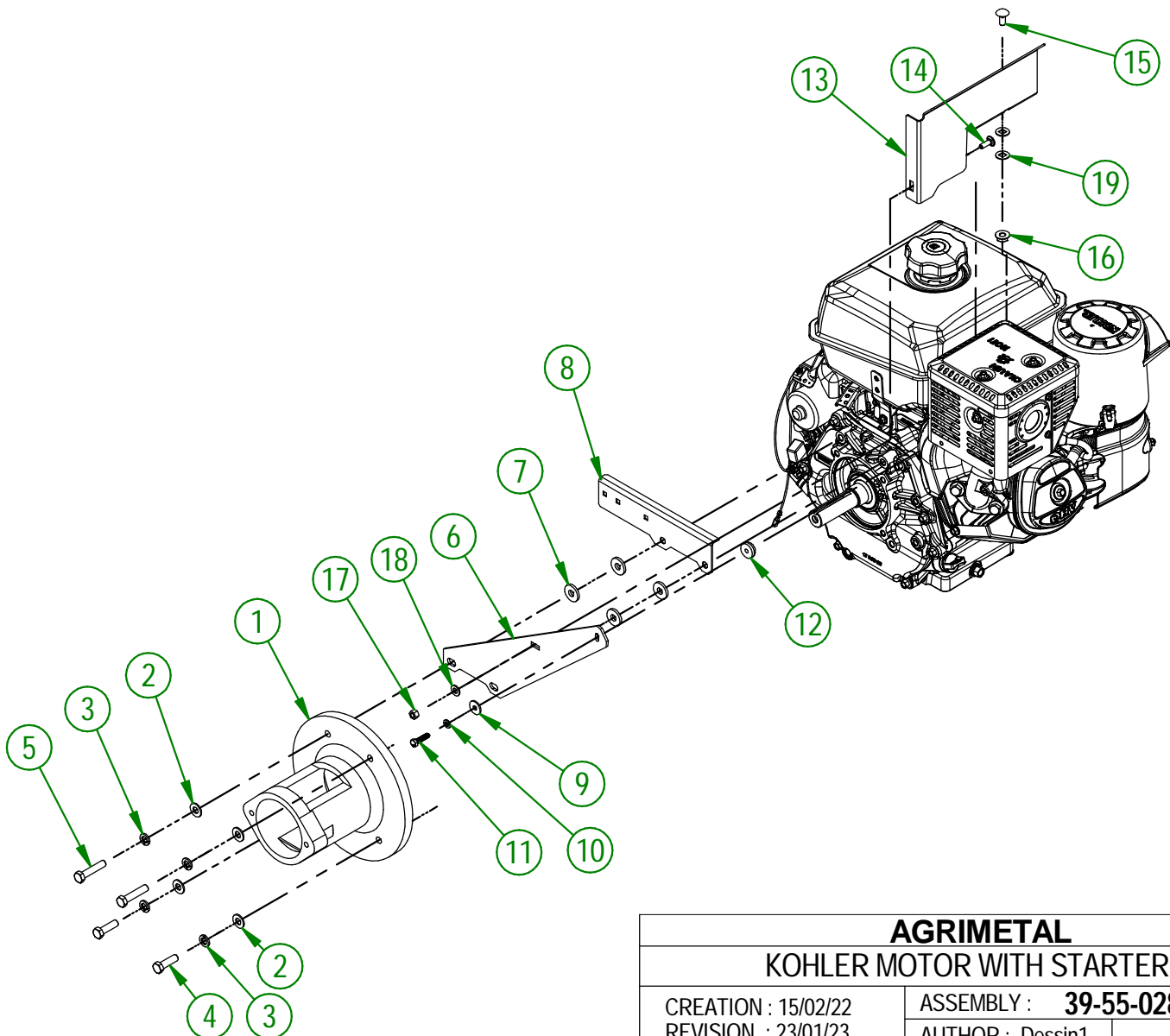

AGRIMETAL	
KOHLER MOTOR WITH STARTER	
CREATION : 15/02/22	ASSEMBLY : 39-55-0285
REVISION : 23/01/23	AUTHOR : Dessin1

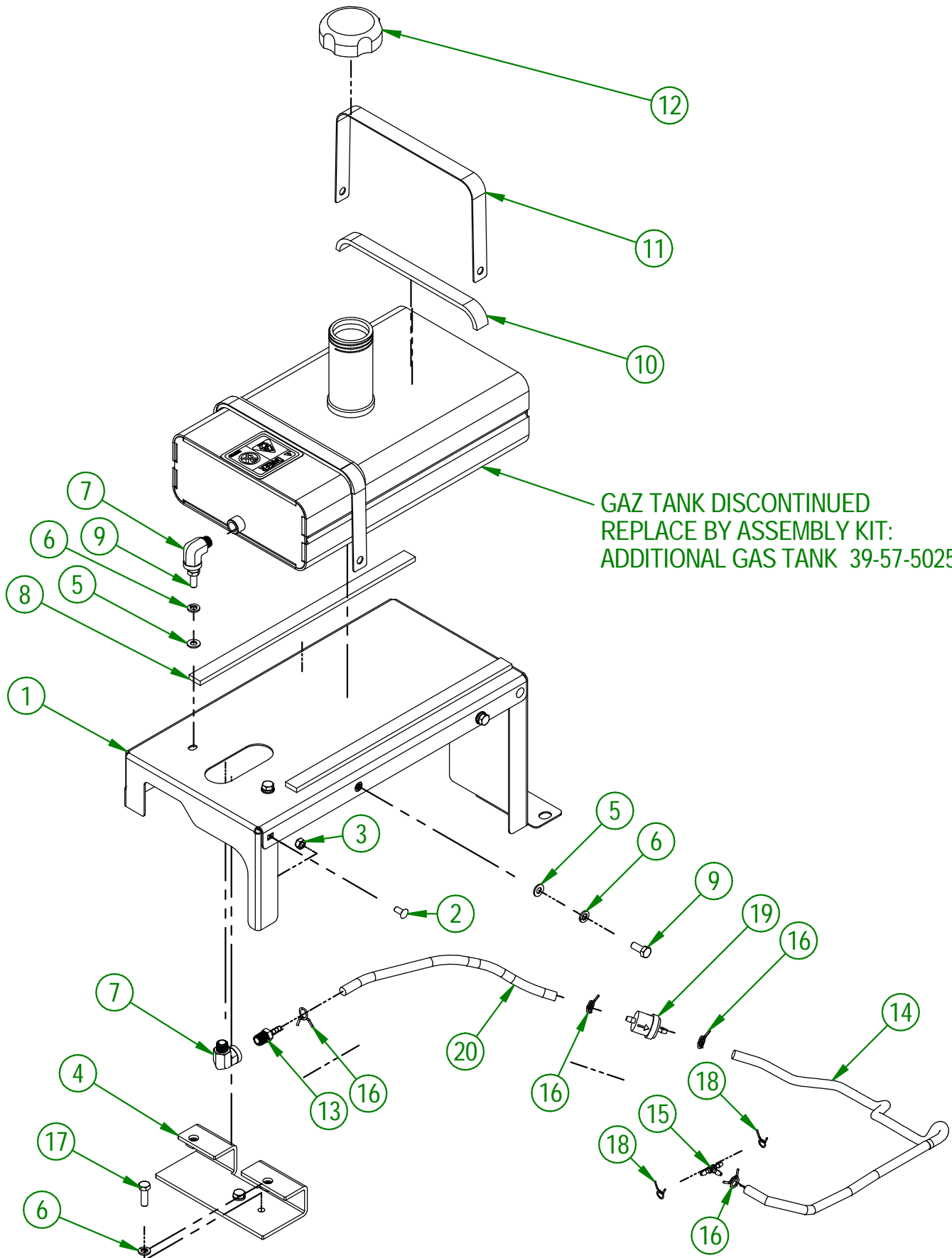

GAZ TANK DISCONTINUED
 REPLACE BY ASSEMBLY KIT:
 ADDITIONAL GAS TANK 39-57-5025

USE THESE PIECES ONLY IF YOUR SERIAL
 NUMBER IS AFFECTED:

#45783 OR LESS

AGRIMETAL	
ADDITIONAL GAS TANK	
CREATION : 12/03/24	ASSEMBLY : 39-57-5001
REVISION : 29/05/24	AUTHOR : D. CHASSÉ

39-57-5001

#	PART #	Qty	TITLE
1	39-57-5010	1	HYDROSTATIC PUMP GUARD
2	NC01-04-0001	5	CARR. BOLT GR2 ZINC 1/4-20 X 1/2"
3	NC01-96-0009	5	NYLON-INSERT LOCKNUT ZINC 1/4-20
4	39-50-5005	1	HYDROSTATIC PUMP GUARD SUPPORT
5	NC02-22-0008	6	WASHER ZINC 5/16"
6	NC02-32-0011	8	LOCK WASHER ZINC 5/16"
7	NC13-45-0142	2	90° 1/4 FEMELLE NPT X 1/4 MALE NPT
8	39-42-0090	2	RUBBER FOAM SEAL TAPE BLACK 1/4" X 3/4" X 14 1/2" LG
9	NC01-17-0058	6	HEX. BOLT GR2 ZINC 5/16-18 X 3/4" LG
10	39-42-0095	2	RUBBER FOAM SEAL TAPE BLACK 1/4" X 3/4" X 9 7/8" LG
11	39-01-6600	2	GAS TANK STRIP SUPPORT
12	NC13-37-0673	1	GAS CAP
13	NC13-68-0022	1	BRASS BARBED FITTING 3/16" X 1/4" NPT
14	39-46-0160	1	1/4" GAS LINE
15	NC13-68-0032	1	PLASTIC BARBED TEE FITTING TEE CONNECTOR 3/16" (GASOLINE)
16	NC01-65-0305	4	CONSTANT-TENSION SPRING CLAMPS 7/16"
17	NC01-17-0060	2	HEX. BOLT GR2 ZINC 5/16-18 X 1"
18	NC01-65-0304	2	CONSTANT-TENSION SPRING CLAMPS 5/16"
19	NC13-37-0688	1	3/16 GAS FILTER
20	39-46-0165	1	1/4" GAS LINE

39-57-5002

#	PART #	Qty	TITLE
1	39-57-5011	1	HYDROSTATIC PUMP GUARD
2	39-57-5008	1	GAZ TANK
3	39-50-5005	1	HYDROSTATIC PUMP GUARD SUPPORT
4	39-01-6605	2	GAS TANK STRIP SUPPORT
5	39-46-0170	1	GAZ LINE
6	NC01-07-0001	5	CARR. BOLT GR5 ZINC 1/4-20 X 1/2"
7	NC01-96-0009	5	NYLON-INSERT LOCKNUT ZINC 1/4-20
8	NC02-22-0008	6	WASHER ZINC 5/16"
9	NC02-32-0011	6	LOCK WASHER ZINC 5/16"
10	NC01-25-0058	6	HEX BOLT GR5 ZINC PLATED 5/16-18 X 3/4"
11	NC13-37-0688	1	3/16 GAS FILTER
12	NC01-65-0305	4	CONSTANT-TENSION SPRING CLAMPS 7/16"
13	NC01-65-0304	2	CONSTANT-TENSION SPRING CLAMPS 5/16"
14	NC13-68-0032	1	PLASTIC BARBED TEE FITTING TEE CONNECTOR 3/16" (GASOLINE)
15	39-42-0205	2	RUBBER FAOM SEAL TAPE BLACK 1/4" X 3" X 8"
16	39-42-0130	1	RUBBER FOAM SEAL TAPE BLACK 3/8" X 3/4" X 1" LG
17	39-46-0175	1	GAZ LINE

39-57-5008

#	PART #	Qty	TITLE
18	NC13-80-0317	1	GAZ CAP
19	NC13-80-0319	1	GROMMET VITRON #468661
20	NC13-80-0318	1	90° ELBOW X 1/4" GAS LINE

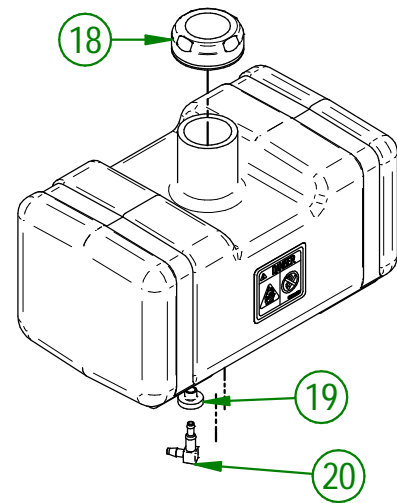
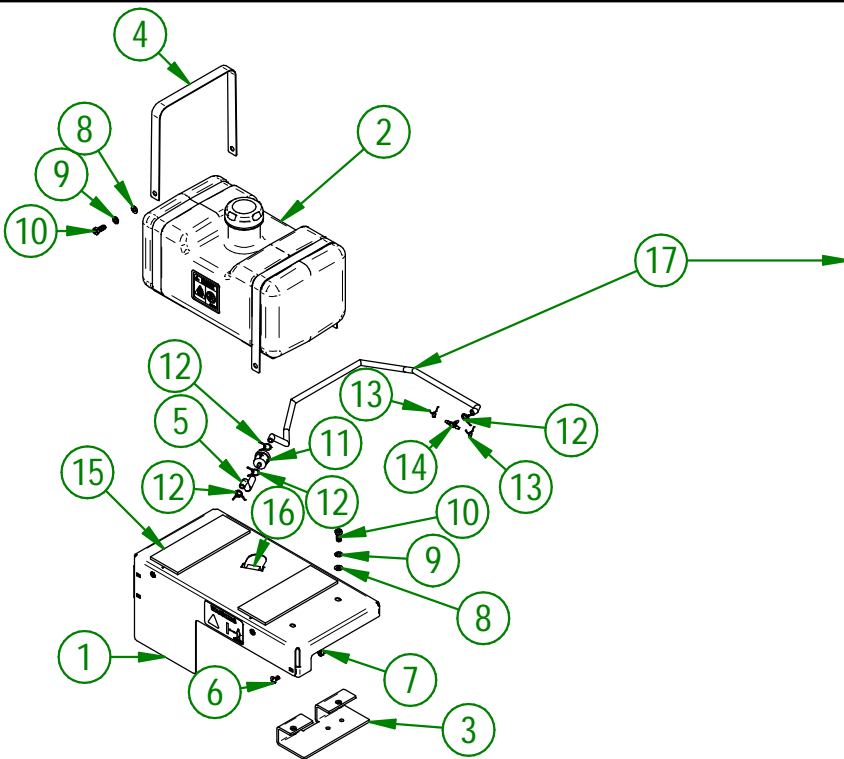

USE THESE PIECES ONLY IF YOUR SERIAL NUMBER IS AFFECTED:

#45784 ET PLUS

AGRIMETAL	
ADDITIONAL FUEL TANK GROUPING	
CREATION : 29/05/24	ASSEMBLY : 39-57-5002
REVISION : 29/05/24	AUTHOR : M. HOULE

39-57-5025

#	PART #	QTY	TITLE
1	39-57-5011	1	HYDROSTATIC PUMP GUARD
2	NC01-07-0001	5	CARR. BOLT GR5 ZINC 1/4-20 X1/2"
3	NC01-96-0009	5	NYLON-INSERT LOCKNUT ZINC 1/4-20
4	39-57-5022	1	3 GALLON GAZ TANK

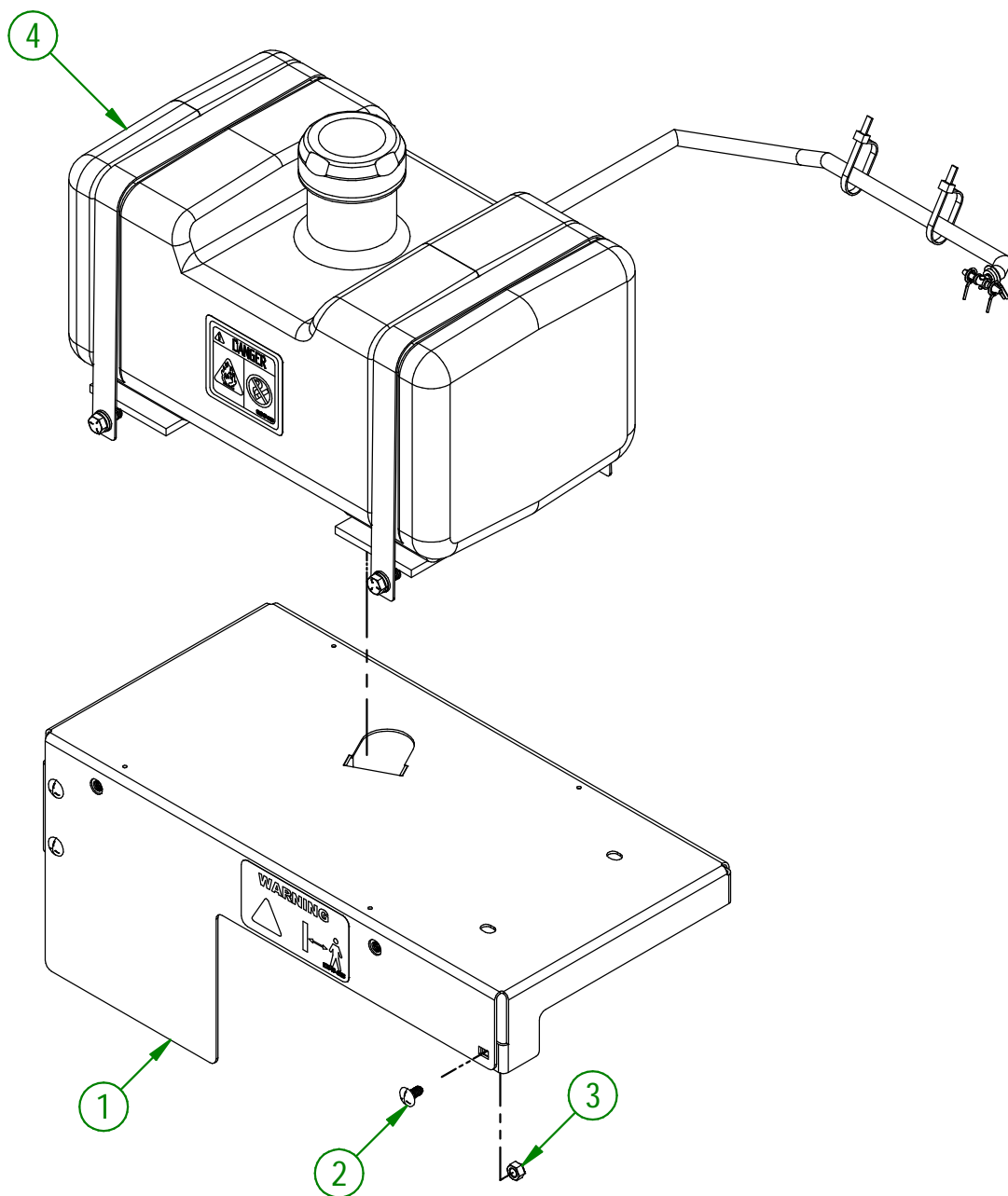

AGRIMETAL	
ADDITIONAL GAS TANK	
CREATION : 22/01/25	ASSEMBLY : 39-57-5025
REVISION : 22/01/25	AUTHOR : D. CHASSÉ

39-57-5022

#	PART #	QT	TITLE
1	39-57-5008	1	GAZ TANK
2	39-01-6605	2	GAS TANK STRIP SUPPORT
3	NC02-22-0008	4	WASHER ZINC 5/16"
4	NC02-32-0011	4	LOCK WASHER ZINC 5/16"
5	NC01-25-0058	4	HEX BOLT GR5 ZINC PLATED 5/16-18 X 3/4"
6	39-46-0170	1	GAZ LINE
7	NC13-37-0688	1	3/16 GAS FILTER
8	39-46-0175	1	GAZ LINE
9	NC01-65-0305	4	CONSTANT-TENSION SPRING CLAMPS 7/16"
10	39-42-0205	2	RUBBER FAOM SEAL TAPE BLACK 1/4" X 3" X 8"
11	NC13-68-0032	1	PLASTIC BARBED TEE FITTING TEE CONNECTOR 3/16" (GASOLINE)
12	NC01-65-0304	2	CONSTANT-TENSION SPRING CLAMPS 5/16"
13	39-42-0130	1	RUBBER FOAM SEAL TAPE BLACK 3/8" X 3/4" X 1" LG
14	NC13-25-0019	3	NYLON CABLE TIE
15	NC13-80-0317	1	GAZ CAP

39-57-5008

#	PART #	QT	TITLE
16	NC13-80-0317	1	GAZ CAP
17	NC13-80-0319	1	GROMMET VITRON #468661
18	NC13-80-0318	1	90° ELBOW X 1/4" GAS LINE

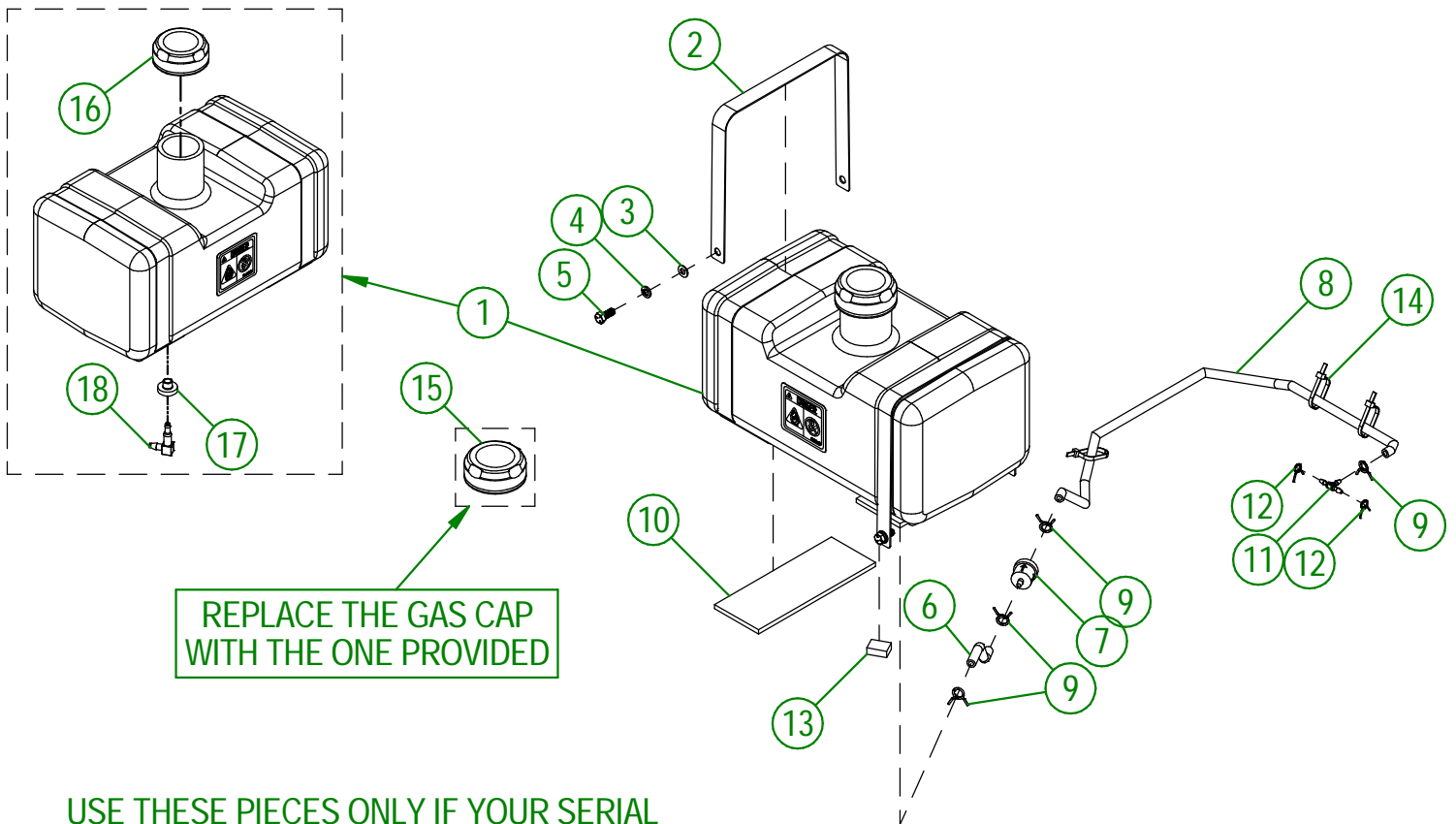

REPLACE THE GAS CAP WITH THE ONE PROVIDED

USE THESE PIECES ONLY IF YOUR SERIAL NUMBER IS AFFECTED:
OR IF YOU HAVE INSTALLED THE KIT 39-57-5025

#46009 ET PLUS

AGRIMETAL	
3 GALLON GAZ TANK OPTION	
CREATION : 29/05/24	ASSEMBLY : 39-57-5022
REVISION : 16/05/25	AUTHOR : M. HOULE

39-57-0190

#	PART #	Qty	TITLE
1	39-55-0700	1	ROLLER ARM
2	NC02-07-0022	2	HEX. NUT ZINC 5/8-11
3	NC02-32-0016	2	LOCK WASHER ZINC 5/8"
4	NC01-17-0398	2	HEX. BOLT GR2 NC ZINC 5/8-11 X 2 1/2"
5	39-21-0055	2	RING

39-55-0700

#	PART #	Qty	TITLE
6	NC01-67-0308	2	MAL ROD END THREAD 5/8-18
7	39-21-0060	1	ARM
8	NC02-10-0022	2	HEX. NUT ZINC 5/8-18

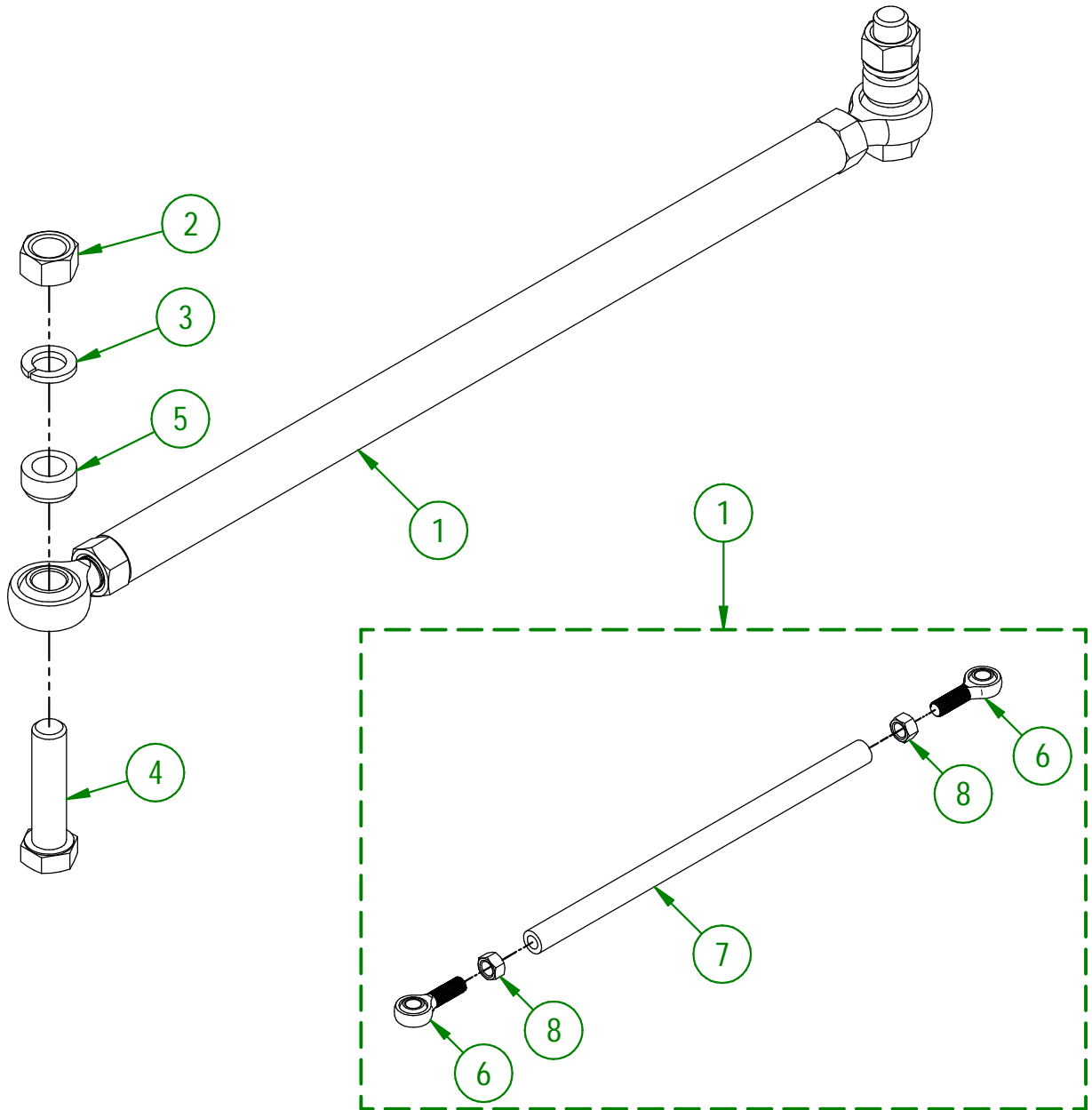

AGRIMETAL	
ROLLER ARM GROUP	
CREATION : 25/04/18	ASSEMBLY : 39-57-0190
REVISION : 15/02/22	AUTHOR : J.KABWE

#	PART #	Qty	TITLE
1	33-01-4000	1	HOUR METER HOLDER
2	33-42-0130	1	BLACK ADHESIVE-BACK STRIP
3	39-01-3050	1	LIGHT SWITCH HOLDER
4	39-21-0040	1	RIGHT LIGHT HOLDER
5	39-42-0200	5	WIRE SHRINK TUBING
6	39-55-0121	2	LED LIGHT
7	39-55-0430	1	RELAY PLUG
8	39-55-0815	1	BATTERY CABLE 36" (POSITIVE) (GR 400)
9	39-55-0820	1	BATTERY CABLE 36" (NAGATIVE) (GR 400)
10	39-57-0195	1	BATTERY STRAPE
11	39-57-0626	1	COMPLETE ELECTRIC WIRE SET
12	NC01-07-0027	2	CARR. BOLT 1/4-20 X 6" LG
13	NC01-25-0058	1	HEX BOLT GR5 ZINC PLATED 5/16-18 X 3/4"
14	NC01-25-0068	1	HEX. BOLT GR2 NC ZINC 5/16-18 X 3"
15	NC01-96-0009	2	NYLON-INSERT LOCKNUT ZINC 1/4-20
16	NC02-32-0011	2	LOCK WASHER ZINC 5/16"
17	NCI3-12-0001	1	12 VOLTS BATTERY
18	NCI3-25-0019	2	NYLON CABLE TIE
19	NCI3-25-0228	5	VINYL UNION TERMINAL 16-14
20	NCI3-25-0229	2	BLACK NYLON CABLE TIE
21	NCI3-25-0245	1	BLACK TIE RAP
22	NCI3-25-0368	1	LIGHT SWITCH
23	NCI3-25-0406	1	12V 40A 5 PINS RELAY
24	NCI3-37-0669	1	HOUR METER
25	NCI3-80-0267	1	RED PROTECTOR FOR BATTERY POST
26	NCI3-80-0268	1	BLACK PROTECTOR FOR BATTERY POST

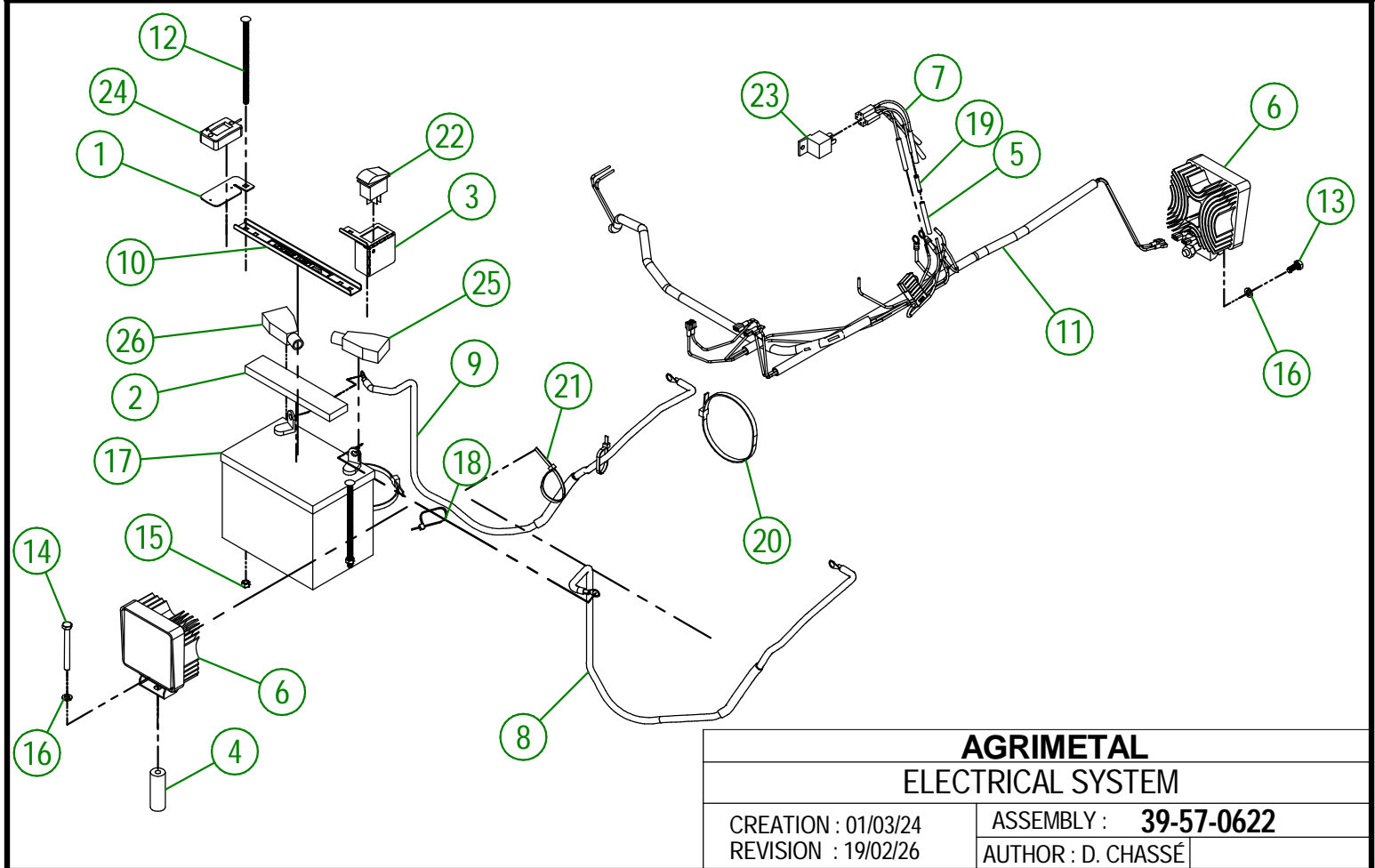

AGRIMETAL
ELECTRICAL SYSTEM

CREATION : 01/03/24
REVISION : 19/02/26

ASSEMBLY : **39-57-0622**
AUTHOR : D. CHASSÉ

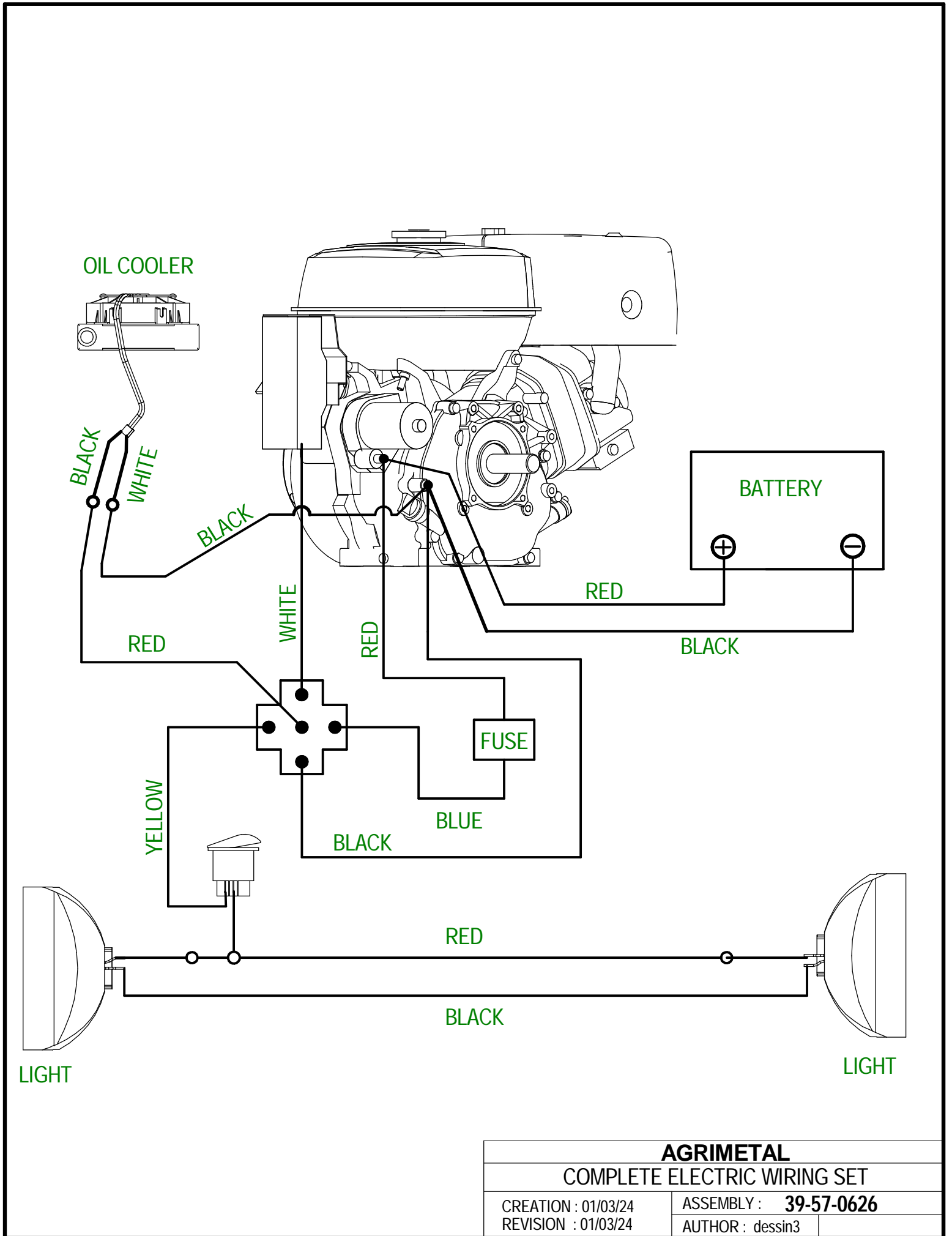

AGRIMETAL	
COMPLETE ELECTRIC WIRING SET	
CREATION : 01/03/24	ASSEMBLY : 39-57-0626
REVISION : 01/03/24	AUTHOR : dessin3

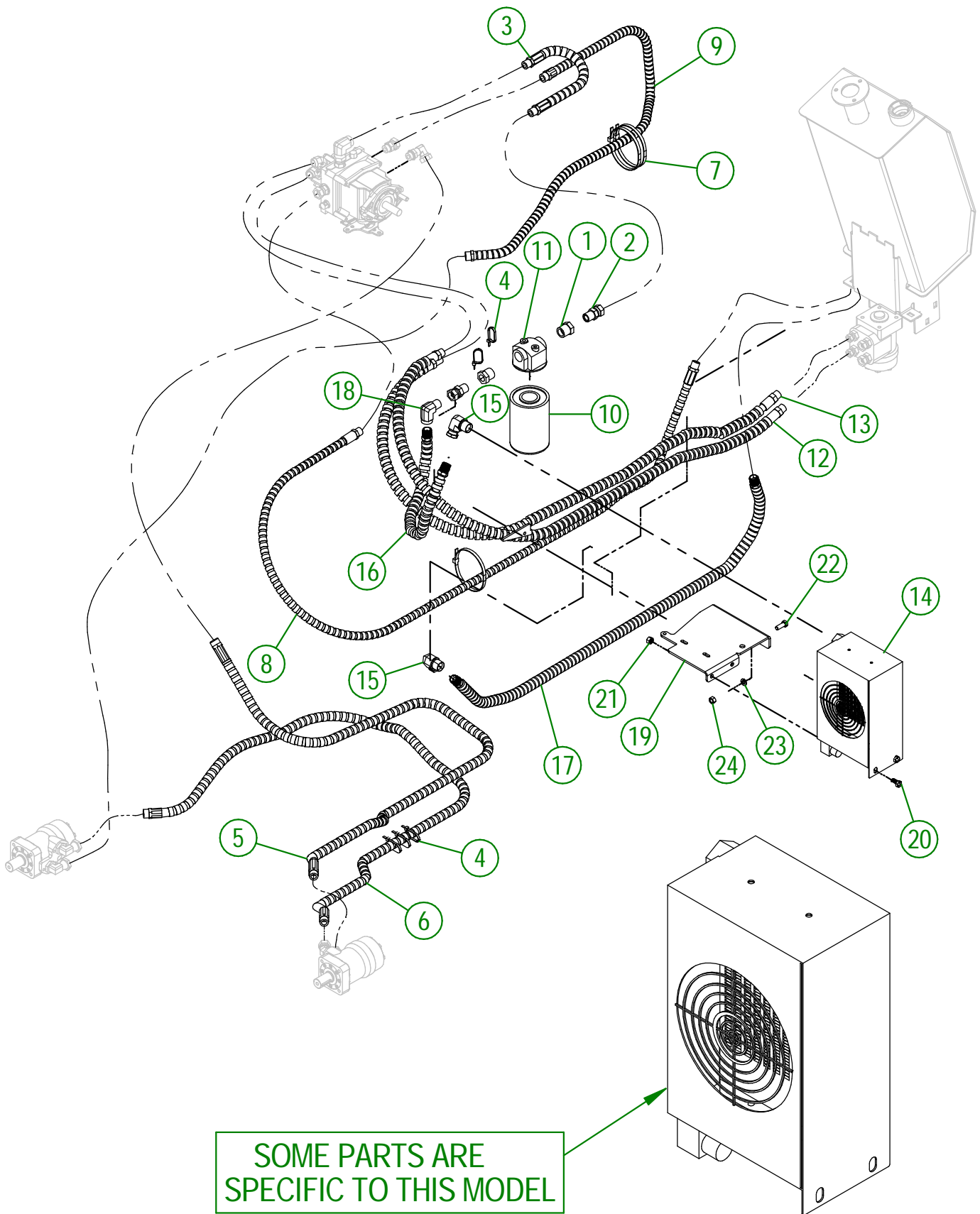

SOME PARTS ARE SPECIFIC TO THIS MODEL

AGRIMETAL	
HYDRAULIC SYSTEM GROUP	
CREATION : 04/03/24	ASSEMBLY : 39-57-0594
REVISION : 11/09/25	AUTHOR : J. Houle

39-57-0594

#	PART #	QTY	TITLE
1	NC13-45-0032	2	STRAIGHT HOSE FITTING 1/2 FEM. NPT X 3/4 MALE NPT
2	NC13-45-0091	2	STRAIGHT HOSE FITTING 1/2 MALE NPTF X 1/2 FEM. SWIVEL
3	NC17-02-0313	1	HYDRAULIC HOSE 19"
4	NC13-25-0019	6	NYLON CABLE TIE
5	NC17-02-0374	1	HYDRAULIC HOSE 63"
6	NC17-02-0372	1	HYDRAULIC HOSE 59"
7	NC13-25-0229	3	BLACK NYLON CABLE TIE
8	39-55-0365	1	HYDRAULIC HOSE 75"
9	NC17-02-0376	1	HYDRAULIC HOSE 37"
10	NC13-45-0048	1	OIL FILTER
11	NC13-45-0049	1	HEAD FILTER
12	NC17-02-0434	1	HYD. HOSE 3/8 X 74"OAL 3/8 NPT MALE RIG. X 3/8 NPT MALE RIG
13	NC17-02-0434	1	HYD. HOSE 3/8 X 74"OAL 3/8 NPT MALE RIG.X 3/8 NPT MALE RIG
14	39-55-0176	1	OIL COOLER AH0608T
15	NC13-45-0402	2	90° ELBOW 3/4 NPT MALE X 1/2 NPT SWIVEL FEMALE
16	39-55-0380	1	HYDRAULIC HOSE 14"
17	39-55-0375	1	HYDRAULIC HOSE 46"
18	NC13-45-0025	1	ELBOW 90° 1/2 FEMALE NPT X 1/2 MALE NPT
19	39-50-0226	1	OIL COOLER SUPPORT
20	NC01-25-0112	2	HEX BOLT ZINC 3/8-16 X 3/4"
21	NC01-93-0011	2	LOCK NUT 3/8-16
22	NC01-25-0114	2	HEX. BOLT GR5 ZINC 3/8-16 X 1"
23	NC02-32-0012	2	LOCK WASHER ZINC 3/8"
24	NC02-07-0018	2	HEX. NUT ZINC 3/8-16

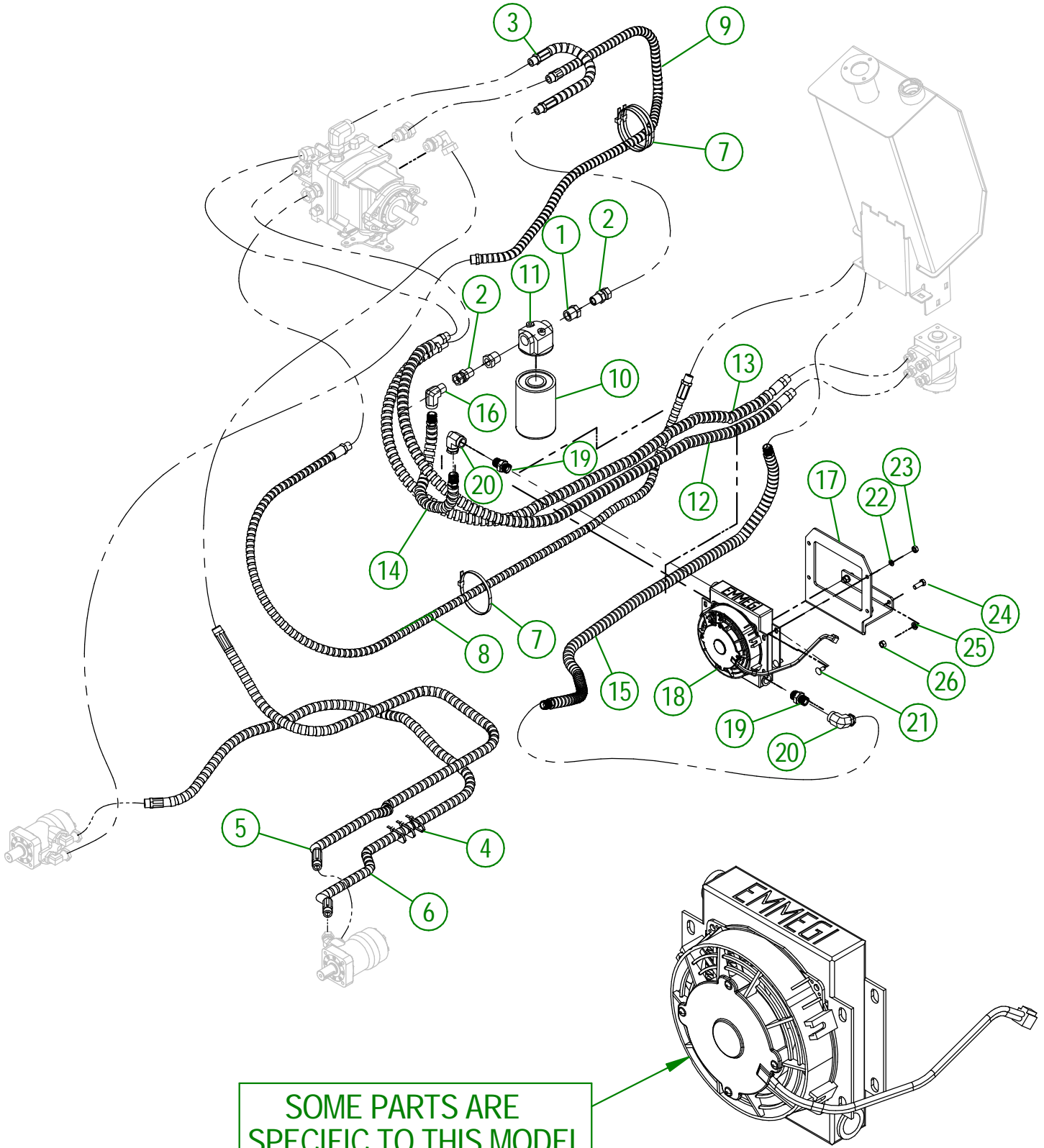

SOME PARTS ARE SPECIFIC TO THIS MODEL

AGRIMETAL	
HYDRAULIC SYSTEM GROUP	
CREATION : 11/03/24	ASSEMBLY : 39-57-0595
REVISION : 11/09/25	AUTHOR : J. Houle

39-57-0595

#	PART #	QTY	TITLE
1	NC13-45-0032	2	STRAIGHT HOSE FITTING 1/2 FEM. NPT X 3/4 MALE NPT
2	NC13-45-0091	2	STRAIGHT HOSE FITTING 1/2 MALE NPTF X 1/2 FEM. SWIVEL
3	NC17-02-0313	1	HYDRAULIC HOSE 19"
4	NC13-25-0019	6	NYLON CABLE TIE
5	NC17-02-0374	1	HYDRAULIC HOSE 63"
6	NC17-02-0372	1	HYDRAULIC HOSE 59"
7	NC13-25-0229	3	BLACK NYLON CABLE TIE
8	39-55-0365	1	HYDRAULIC HOSE 75"
9	NC17-02-0376	1	HYDRAULIC HOSE 37"
10	NC13-45-0048	1	OIL FILTER
11	NC13-45-0049	1	HEAD FILTER
12	NC17-02-0434	1	HYD. HOSE 3/8 X 74"OAL 3/8 NPT MALE RIG. X 3/8 NPT MALE RIG
13	NC17-02-0434	1	HYD. HOSE 3/8 X 74"OAL 3/8 NPT MALE RIG.X 3/8 NPT MALE RIG
14	39-55-0380	1	HYDRAULIC HOSE 14"
15	39-55-0388	1	HYDRAULIC HOSE 48"
16	NC13-45-0025	1	ELBOW 90° 1/2 FEMALE NPT X 1/2 MALE NPT
17	39-04-0705	1	OIL COOLING SUPPORT
18	NC13-45-0399	1	12V OIL COOLER FAN
19	NC13-45-0396	2	1/2" M. BSPP X 1/2" M. NPT STRAIGHT ADAPTOR
20	NC13-45-0395	2	90° ELBOW NPTF
21	NC01-07-0056	4	CARR. BOLT GR5 NC ZINC 5/16-18 X 3/4"
22	NC02-32-0011	4	LOCK WASHER ZINC 5/16"
23	NC02-07-0017	4	HEX. NUT 5/16-18
24	NC01-25-0114	2	HEX. BOLT GR5 ZINC 3/8-16 X 1"
25	NC02-32-0012	2	LOCK WASHER ZINC 3/8"
26	NC02-07-0018	2	HEX. NUT ZINC 3/8-16

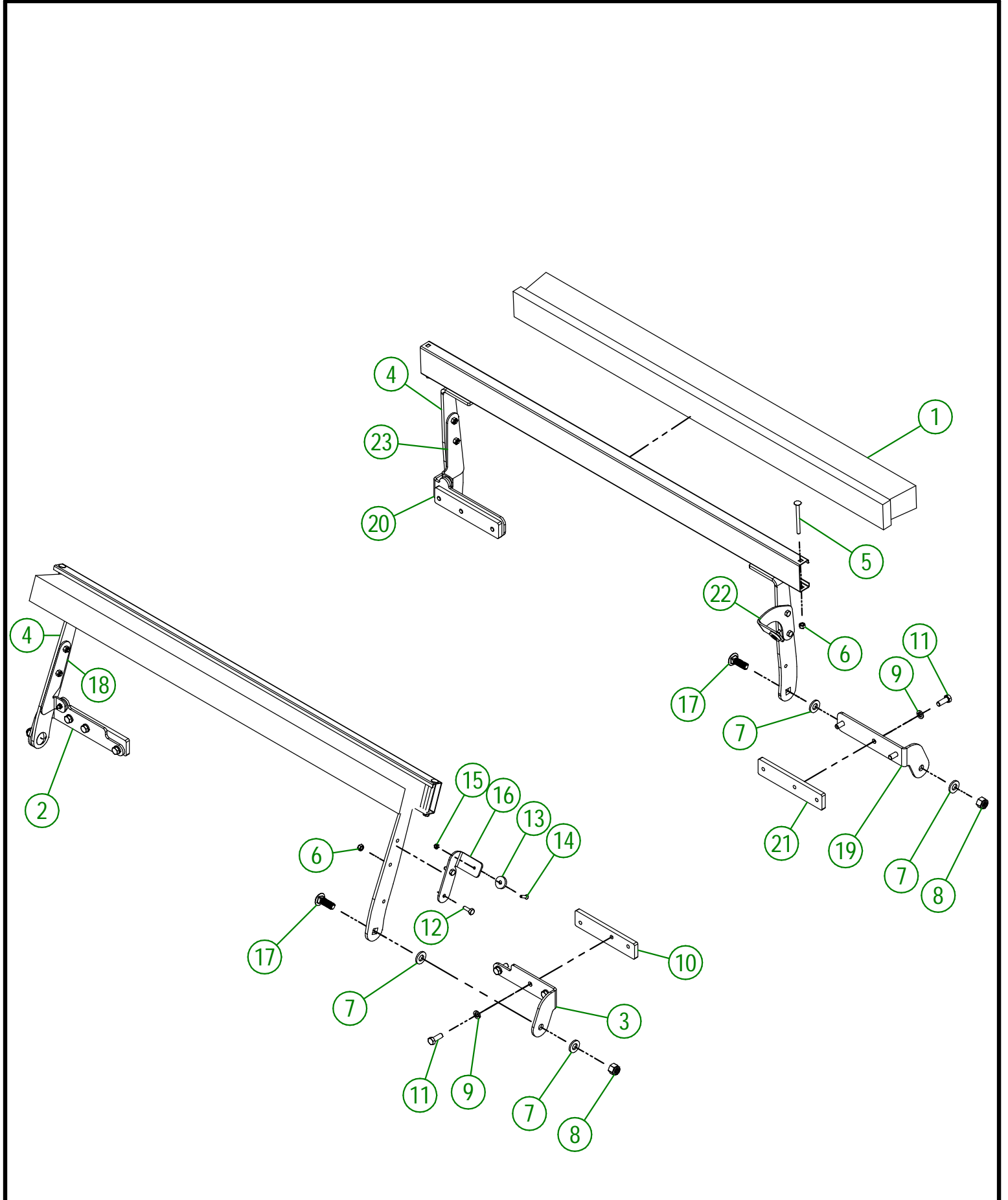

AGRIMETAL	
BRUSHES KIT	
CREATION : 06/02/24	ASSEMBLY : 39-57-9115
REVISION : 05/11/24	AUTHOR : D. CHASSÉ

39-57-9115

#	PART #	QTY	TITLE
1	NC13-80-0294	2	BRUSH
2	39-04-0527	1	BRUSH HOLDER (FRONT-LEFT)
3	39-04-0525	1	BRUSH HOLDER (REAR-LEFT)
4	39-50-9100	2	BRUSH SUPPORT
5	NC01-05-0013	4	CARR. BOLT GR5 ZINC 1/4-20 X 3/4"
6	NC01-96-0009	12	NYLON-INSERT LOCKNUT ZINC 1/4-20
7	NC02-25-0011	8	WASHER SAE ZINC 17/32 ID
8	NC01-96-0014	4	NYLON-INSERT LOCKNUT ZINC 1/2-13
9	NC02-32-0012	12	LOCK WASHER ZINC 3/8"
10	39-05-0510	2	PLATE FOR BRUSH HOLDER (LEFT)
11	NC01-25-0114	12	HEX. BOLT GR2 ZINC 3/8-16 X 1"
12	NC01-25-0004	8	HEX. BOLT GR5 ZINC 1/4-20 X 3/4"
13	NC13-05-0008	4	MAGNET
14	NC02-36-0110	4	MACHINE SCREW FLAT HEAD 10-24 X 3/4" LG.
15	NC01-96-0006	4	NYLON NUT ZINC 3/16
16	39-01-0301	1	MAGNET HOLDER (LEFT)
17	NC01-07-0235	4	CARR. BOLT ZINC GR5 1/2-13 X 1 1/2"
18	39-01-0485	1	MAGNET HOLDER (RIGHT)
19	39-04-0540	1	BRUSH HOLDER (REAR-RIGHT)
20	39-04-0543	1	BRUSH HOLDER (FRONT-RIGHT)
21	39-05-0506	2	PLATE FOR BRUSH HOLDER
22	39-01-0306	1	MAGNET HOLDER (RIGHT)
23	39-01-0480	1	MAGNET SUPPORT (LEFT)

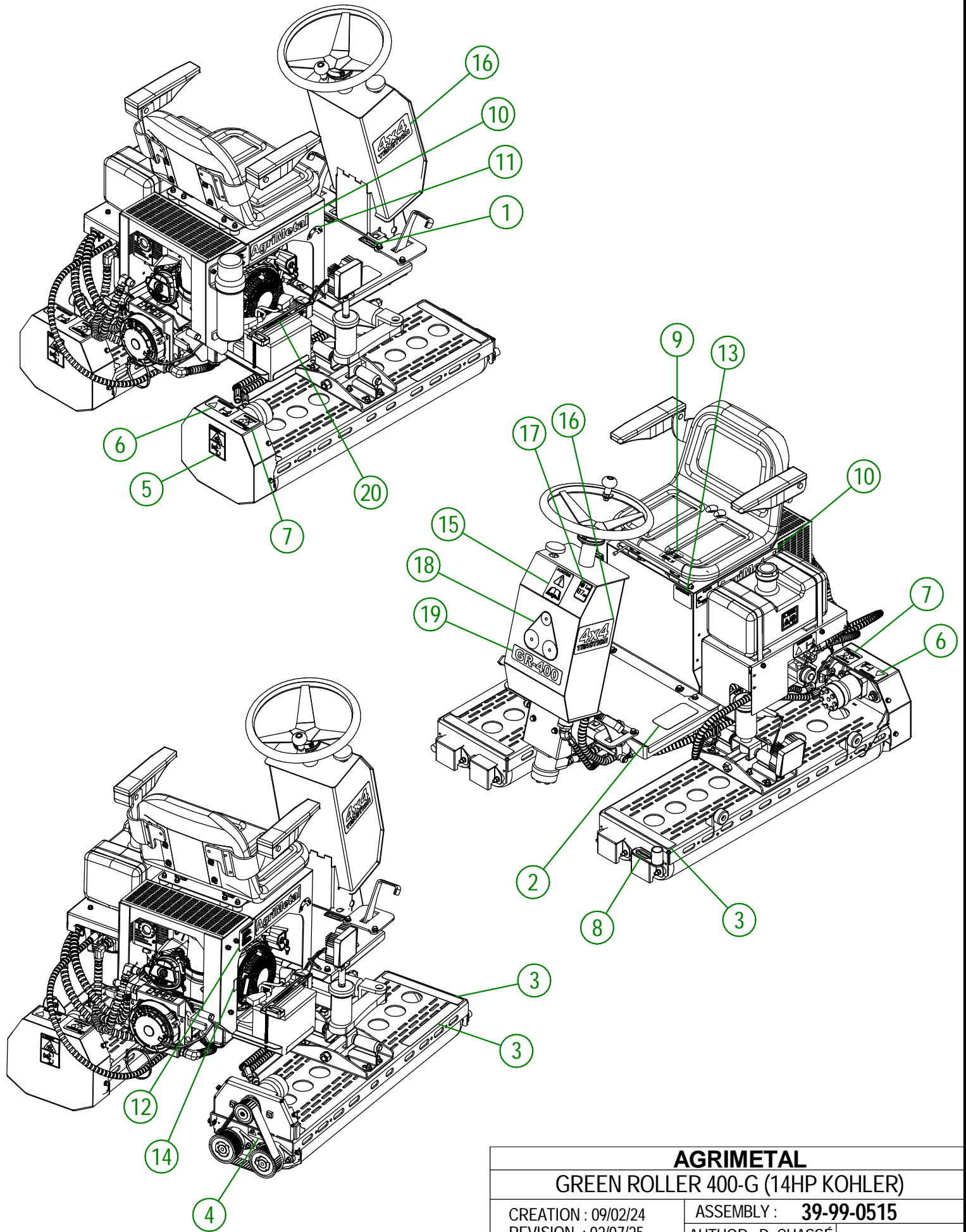

AGRIMETAL	
GREEN ROLLER 400-G (14HP KOHLER)	
CREATION : 09/02/24	ASSEMBLY : 39-99-0515
REVISION : 02/07/25	AUTHOR : D. CHASSÉ

#	PART #	QTY	TITLE
1	NC13-33-0124	2	STICKER STEERING ARROW
2	NC13-80-0082	2	STICKER ANTI-SCRATCH 3" X 6"
3	NC13-80-0081	3	STICKER ANTI-SLIP ROUND CORNER BLACK 1 1/2" X 12"
4	NC13-33-0351	2	STICKER DANGER
5	NC13-33-0282	2	STICKER DANGER
6	NC13-33-0288	2	STICKER WARNING HIGH-PRESSURE LIQUID
7	NC13-33-0355	2	TENSION BELT STICKER
8	NC13-33-2695	1	FLAG HOLDER STICKER
9	NC13-33-0185	2	STICKER PICTOGRAM (FIRE + CIGARETTE)
10	NC13-33-2687	2	STICKER AGRIMETAL
11	NC13-33-0095	1	STICKER OFF ON START
12	NC13-33-0151	1	STICKER (IMPORTANT TO PREVENT ENGINE FAILURE...)
13	NC13-33-0178	1	STICKER IMPORTANT PLEASE CHECK OIL LEVEL...
14	NC13-33-2662	1	ON OFF CHOKE/GAZ STICKER
15	NC13-33-0183	1	STICKER CAUTION OPERATION MANUAL
16	NC13-33-2682	2	STICKER 4 X 4
17	NC13-33-0153	1	STICKER 87 DB
18	NC13-33-2678	1	STICKER SYNCHRO BELT DRIVE
19	NC13-33-2684	1	STICKER GR 400
20	NC13-33-0350	1	STICKER LIGHT SWITCH