

AgriMetal

PARTS LIST

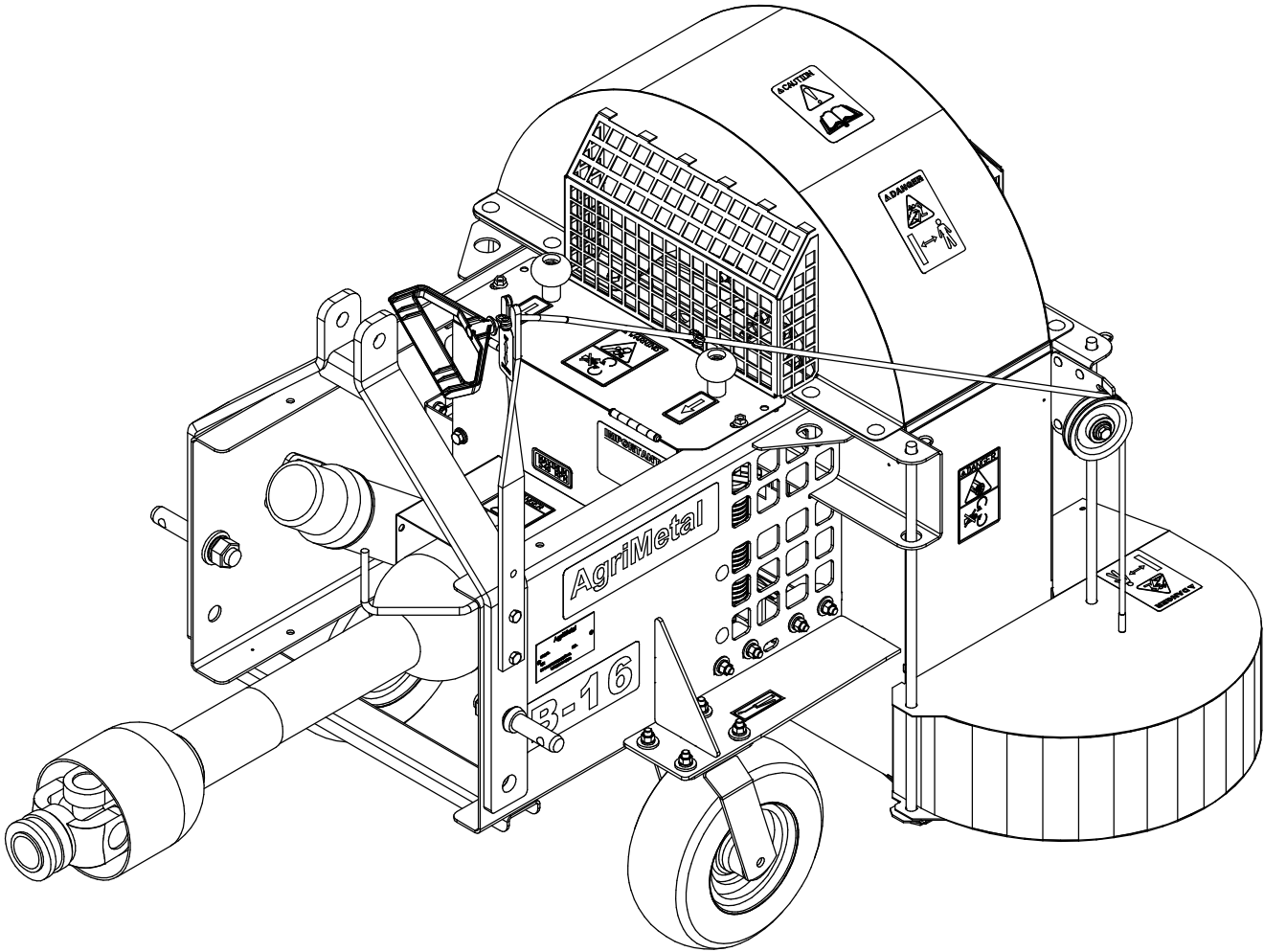

B-16W

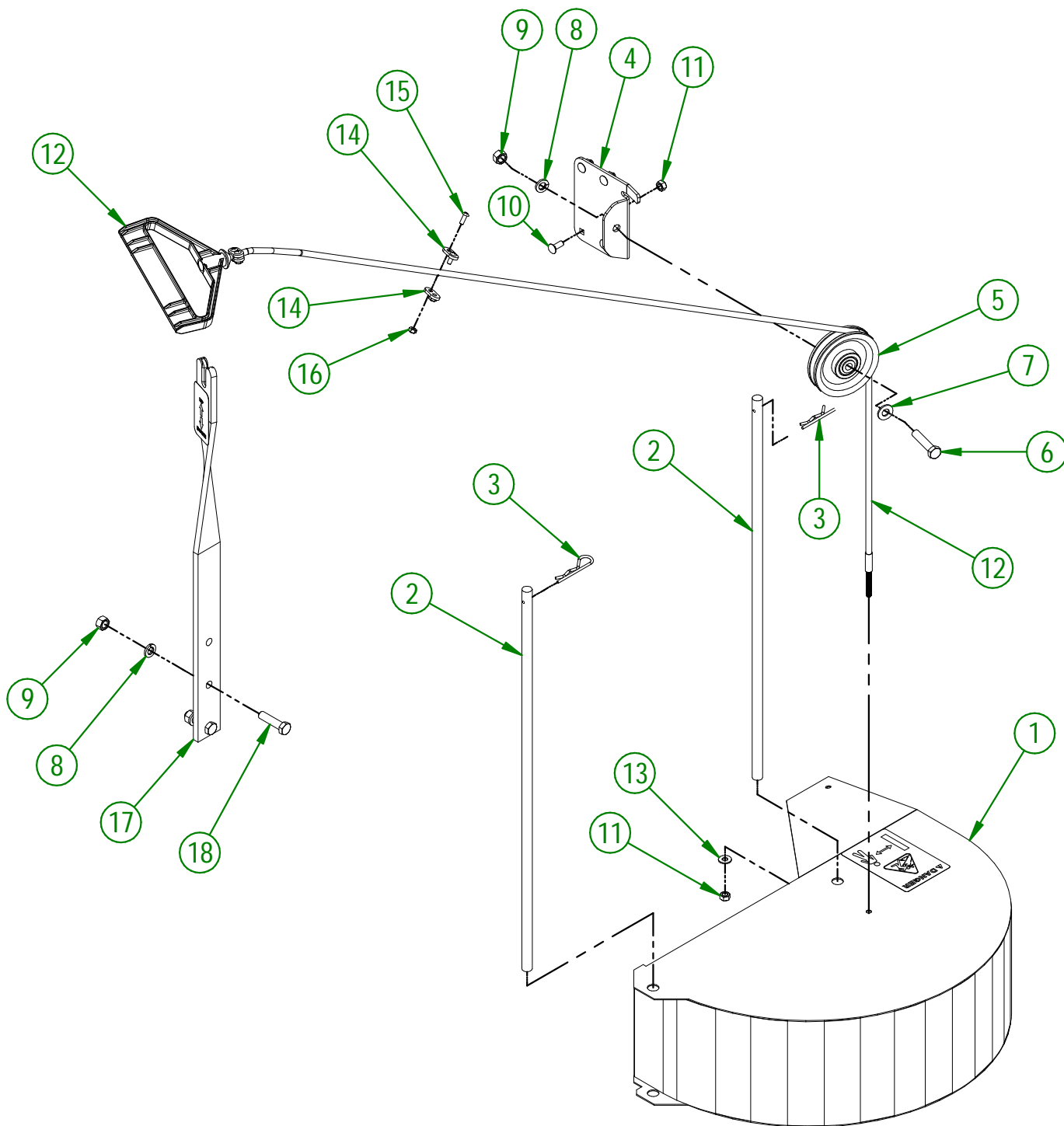

AGRIMETAL	
ASSEMBLY 180° DEFLECTOR	
CREATION : 2016-06-20	ASSEMBLY : 32-57-0090
REVISION : 2022-06-16	AUTHOR : F.H.

32-57-0090

#	PART #	Qty	TITLE
1	32-57-0015	1	ASSEMBLY DEFLECTOR
2	32-13-0600	2	DEFLECTOR GUIDE BW 1600
3	NC01-63-0015	2	COTTER PIN Z 1/8" X 2 5/8"
4	32-01-0945	1	PULLEY SUPPORT
5	NC14-63-0001	1	PULLEY PLASTIC 3 1/2" OD X BEARING 3/8"
6	NC01-17-0117	1	HEX. BOLT GR2 ZINC 3/8-16 X 1 3/4"
7	01-01-2485	1	FLAT WASHER 14 GA X 13/16"OD X 25/64" ID
8	NC02-32-0012	3	LOCK WASHER ZINC 3/8"
9	NC02-07-0018	3	HEX. NUT ZINC 3/8-16
10	NC01-04-0002	4	CARR. BOLT GR2 ZINC 1/4-20 X 5/8"
11	NC01-96-0009	5	NYLON-INSERT LOCKNUT ZINC 1/4-20
12	32-55-0070	1	DEFLECTOR CABLE
13	NC02-25-0007	1	WASHER ZINC 0.281 = 9/32
14	32-22-5600	4	BRACKET FOR CABLE
15	NC02-40-0082	4	MACHINE SCREW PHILLIPS ZINC 10-24 OU 3/16"
16	NC01-96-0006	4	NYLON NUT ZINC 3/16
17	32-57-0065	1	CABLE SUPPORT
18	NC01-17-0116	2	HEX. BOLT GR2 ZINC 3/8-16 X 1 1/2"

32-57-5030

#	PART #	Qty	TITLE
1	NC02-32-0012	4	LOCK WASHER ZINC 3/8"
2	NC02-07-0018	4	HEX. NUT ZINC 3/8-16
3	NC02-25-0011	4	WASHER SAE ZINC 17/32 ID
4	NC01-04-0110	4	CARR. BOLT GR2 ZINC 3/8-16 X 1 1/4"
5	32-55-5015	1	SWIVEL WHEEL

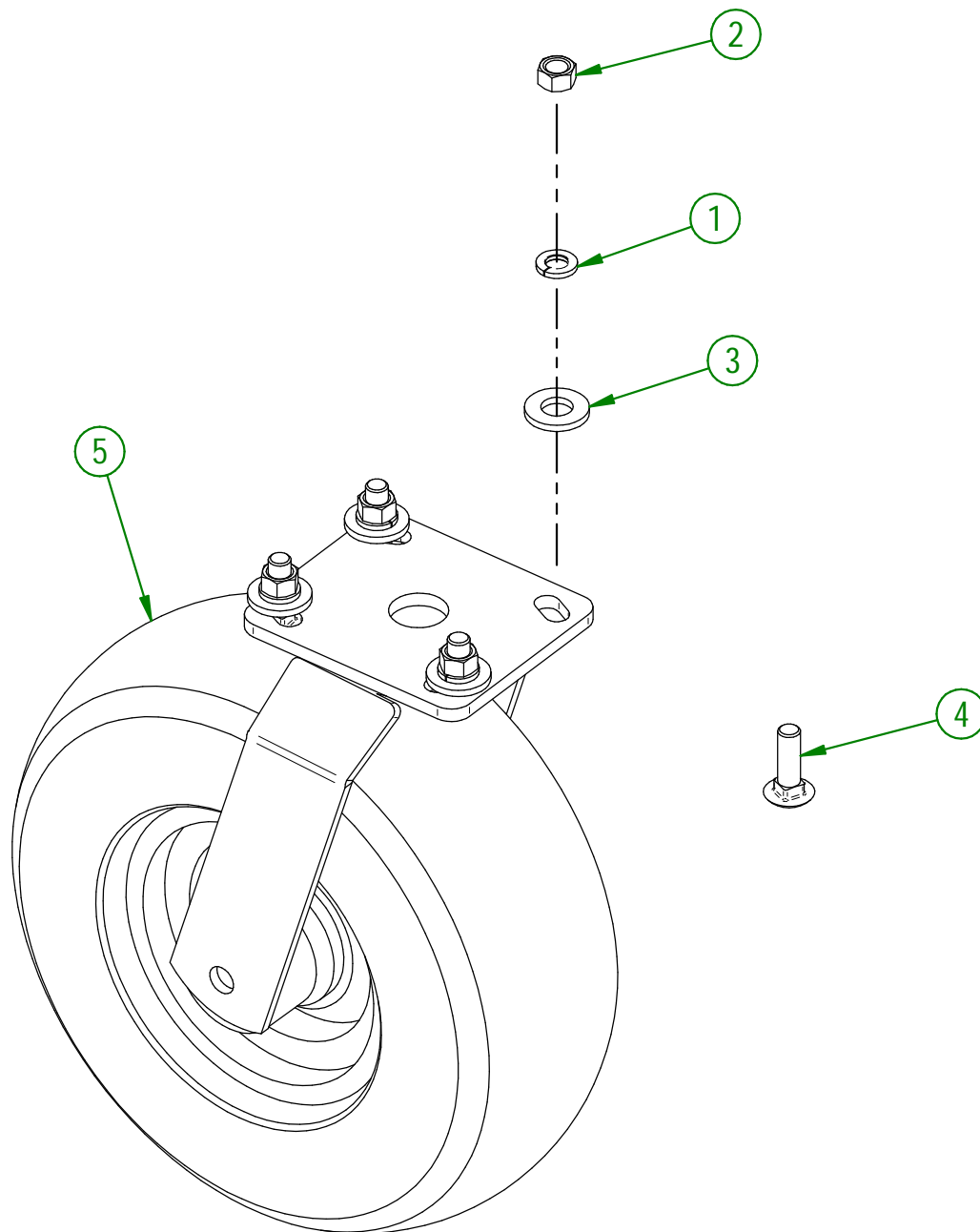

AGRIMETAL	
SWIVEL WHEEL	
CREATION : 16/06/22	ASSEMBLY : 32-57-5030
REVISION : 16/02/24	AUTHOR : J. Houle

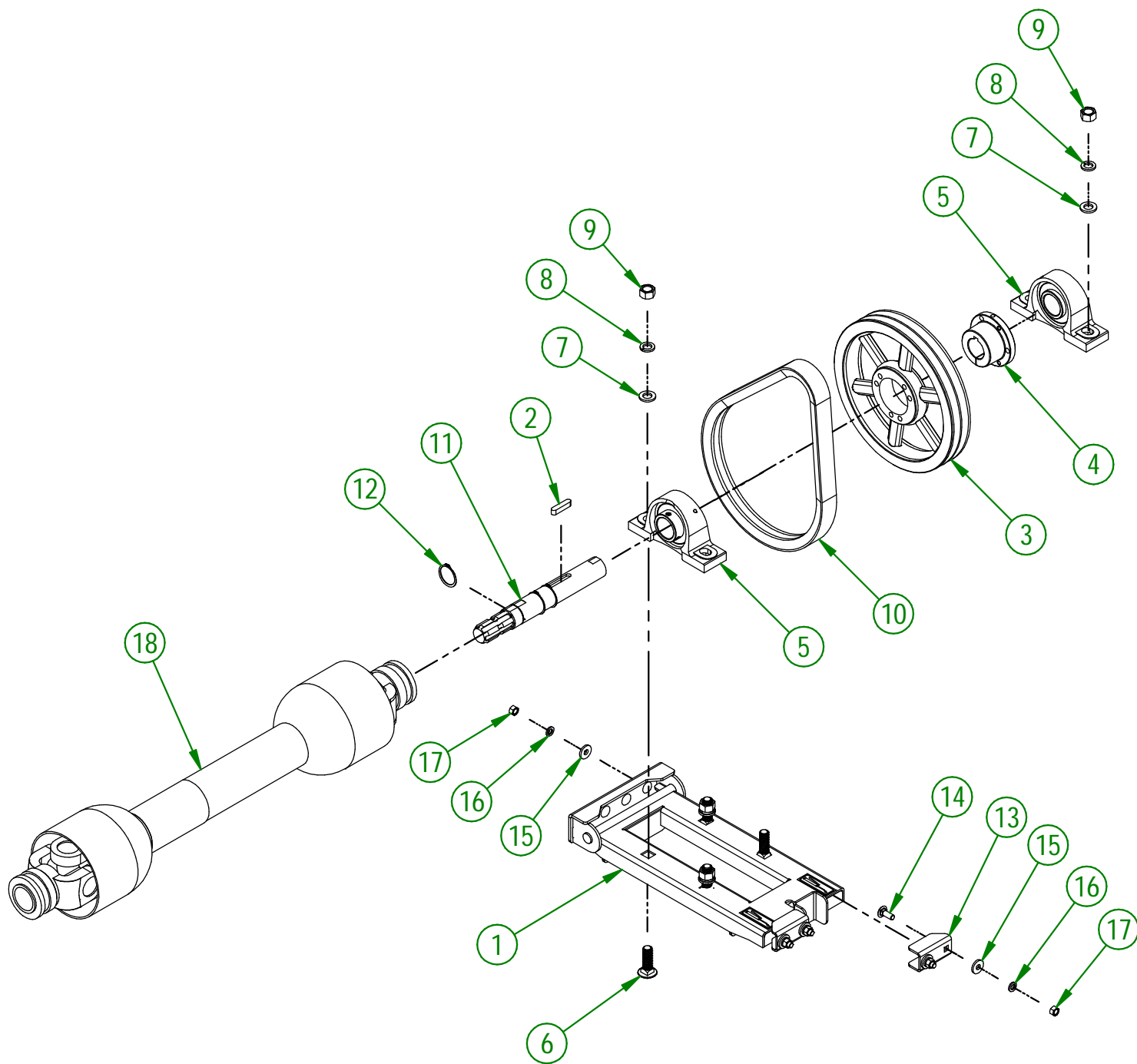

USE THESE PIECES ONLY IF YOUR SERIAL
NUMBER IS AFFECTED:

#43989 AND UNDER

AGRIMETAL	
ASSEMBLY BEARING BASE	
CREATION : 16/06/22	ASSEMBLY : 32-57-5015
REVISION : 20/04/23	AUTHOR : J. Houle

32-57-5015

#	PART #	Qty	TITLE
1	32-57-5025	1	ASSEMBLY BEARING BASE
2	NC01-65-0100	1	KEY 3/8 X 3/8 X 1 3/4"
3	NC14-62-0184	1	PULLEY QD 2V 1/2-5/8 X 11.35 OD X SK
4	NC14-62-0021	1	QD BUSHING SK 1 1/2"
5	NC14-75-0035	2	PILLOW BLOCK SUPPORT UCP208-24 ϕ 1 1/2"
6	NC01-04-0268	4	BOLT CARR. GR2 ZINC 5/8-11 X 2"
7	32-01-1395	4	BEARING WHASER ϕ 3/4"
8	NC02-32-0016	4	LOCK WASHER ZINC 5/8"
9	NC02-07-0022	4	HEX. NUT ZINC 5/8-11
10	NC14-25-5374	1	V BELT 21/32 DOUBLE COGGED RAW EDGE BX-40
11	32-20-0067	1	PTO SHAFT
12	NC01-64-0022	3	QD BUSHING
13	32-01-1080	2	BEARING BASE STOPPER
14	NC01-04-0109	8	CARR. BOLT GR2 ZINC 3/8-16 X 1"
15	21-01-0950	8	FLAT WASHER 10GA 1.005" DIA X 25/64"
16	NC02-32-0012	8	LOCK WASHER ZINC 3/8"
17	NC02-07-0018	8	HEX. NUT ZINC 3/8-16
18	32-34-0035	1	PTO SHAFT T20 X 35.35"

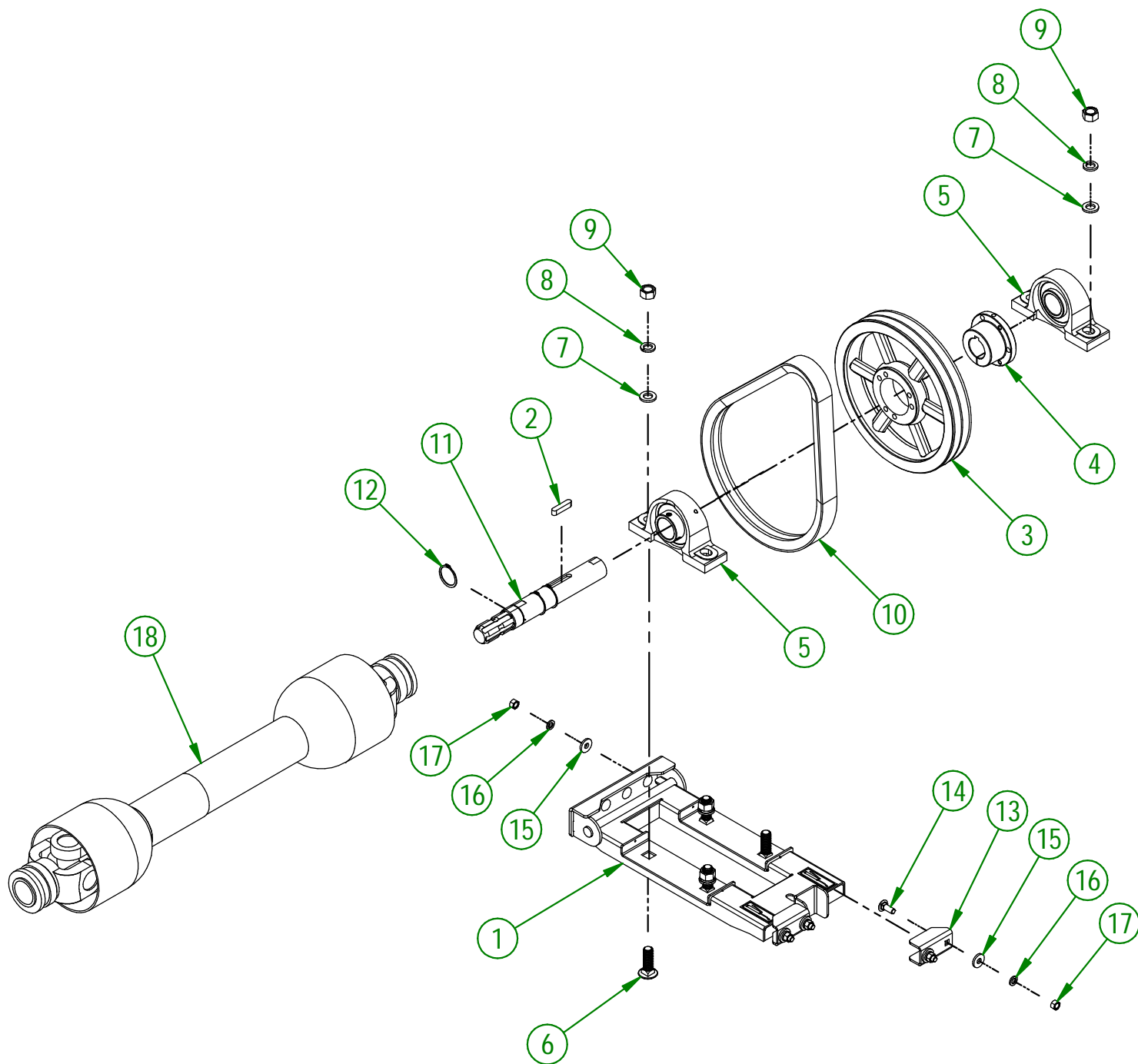

USE THESE PIECES ONLY IF YOUR SERIAL
NUMBER IS AFFECTED:

#43990 AND ABOVE

AGRIMETAL	
ASSEMBLY BEARING BASE	
CREATION : 20/04/23	ASSEMBLY : 32-57-5016
REVISION : 20/04/23	AUTHOR : J. Houle

32-57-5016

#	PART #	Qty	TITLE
1	32-57-5026	1	ASSEMBLY BEARING BASE
2	NC01-65-0100	1	KEY 3/8 X 3/8 X 1 3/4"
3	NC14-62-0184	1	PULLEY QD 2V 1/2-5/8 X 11.35 OD X SK
4	NC14-62-0021	1	QD BUSHING SK 1 1/2"
5	NC14-75-0035	2	PILLOW BLOCK SUPPORT UCP208-24 ϕ 1 1/2"
6	NC01-04-0268	4	BOLT CARR. GR2 ZINC 5/8-11 X 2"
7	32-01-1395	4	BEARING WHASER ϕ 3/4"
8	NC02-32-0016	4	LOCK WASHER ZINC 5/8"
9	NC02-07-0022	4	HEX. NUT ZINC 5/8-11
10	NC14-25-5378	1	V BELT 21/32 DOUBLE (CONTITECH) BX-40
11	32-20-0067	1	PTO SHAFT
12	NC01-64-0022	3	QD BUSHING
13	32-01-1080	2	BEARING BASE STOPPER
14	NC01-04-0109	8	CARR. BOLT GR2 ZINC 3/8-16 X 1"
15	21-01-0950	8	FLAT WASHER 10GA 1.005" DIA X 25/64"
16	NC02-32-0012	8	LOCK WASHER ZINC 3/8"
17	NC02-07-0018	8	HEX. NUT ZINC 3/8-16
18	32-34-0035	1	PTO SHAFT T20 X 35.35"

32-57-0085

#	# DE PIÈCE	QTÉ	TITRE
1	NC17-46-0018	2	HANDLE KNOB
2	NC01-17-0119	2	HEX. BOLT GR2 ZINC 3/8-16 X 2 1/4"
3	NC02-32-0012	6	LOCK WASHER ZINC 3/8"
4	NC02-07-0018	2	HEX. NUT ZINC 3/8-16
5	01-01-2485	6	FLAT WASHER 14 GA X 13/16"OD X 25/64" ID
6	32-57-4100	1	BELT GUARD
7	NC01-17-0112	4	HEX. BOLT GR2 ZINC 3/8-16 X 3/4"
8	NC01-04-0055	2	CARR. BOLT GR2 ZINC 5/16-18 X 5/8"
9	NC01-96-0010	2	NYLON NUT HEX. ZINC 5/16-18

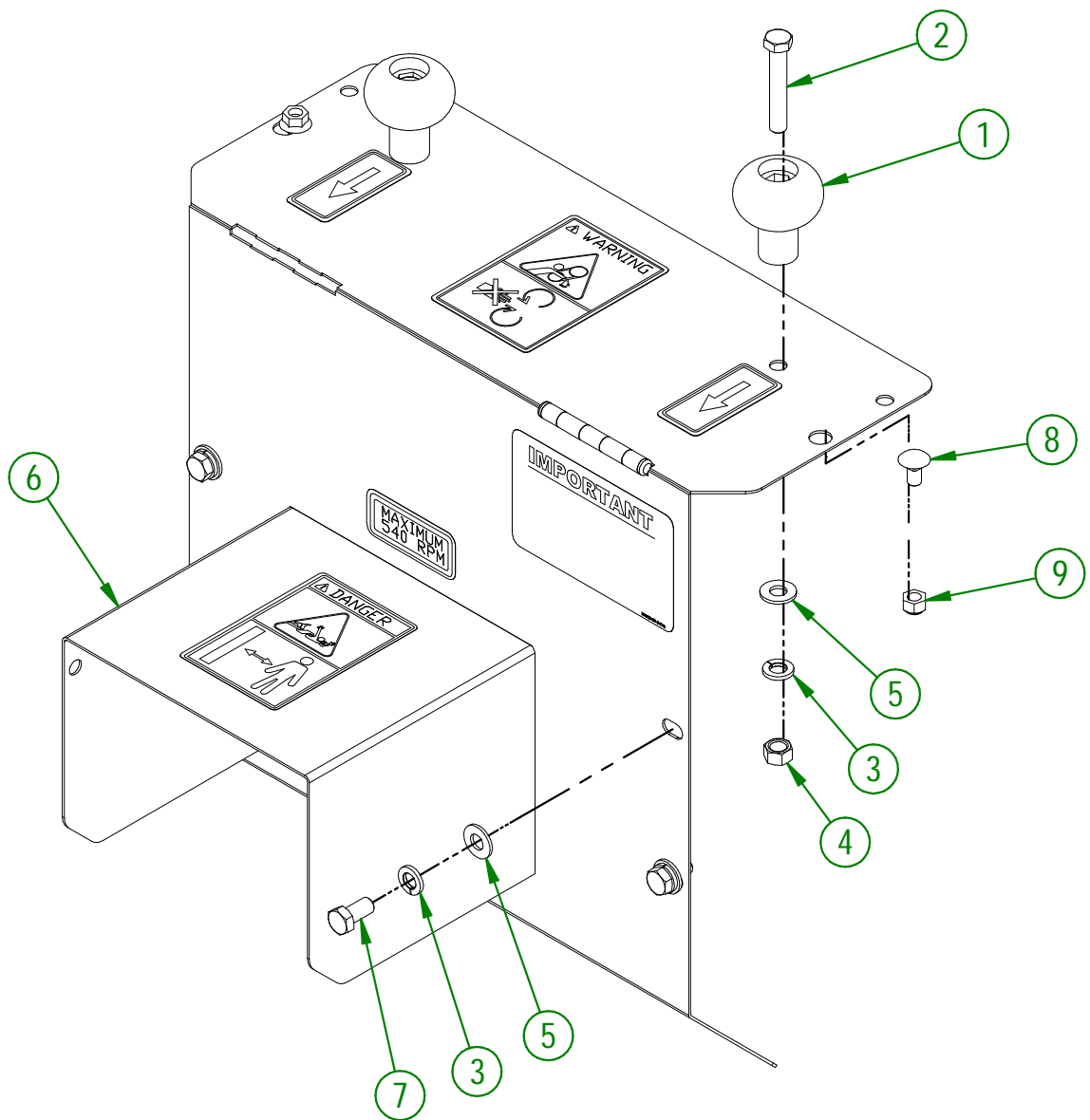

AGRIMETAL	
ASSEMBLY BELT COVER	
CREATION : 2016-06-20	ASSEMBLY : 32-57-0085
REVISION : 2022-06-16	AUTHOR :

#	PART #	Qty	TITLE
1	32-50-3530	1	WELD ASSEMBLY THREADED ROD
2	32-42-0115	1	SPRING GUIDE
3	32-42-0140	1	SPRING STOPPER
4	NC13-86-0083	1	BLUE SPRING 1/2" ID X 1" OD X 8"
5	NC02-25-0011	1	WASHER SAE ZINC 17/32 ID
6	32-01-3075	1	HANDLE
7	NC02-07-0020	2	HEX. NUT ZINC 1/2-13

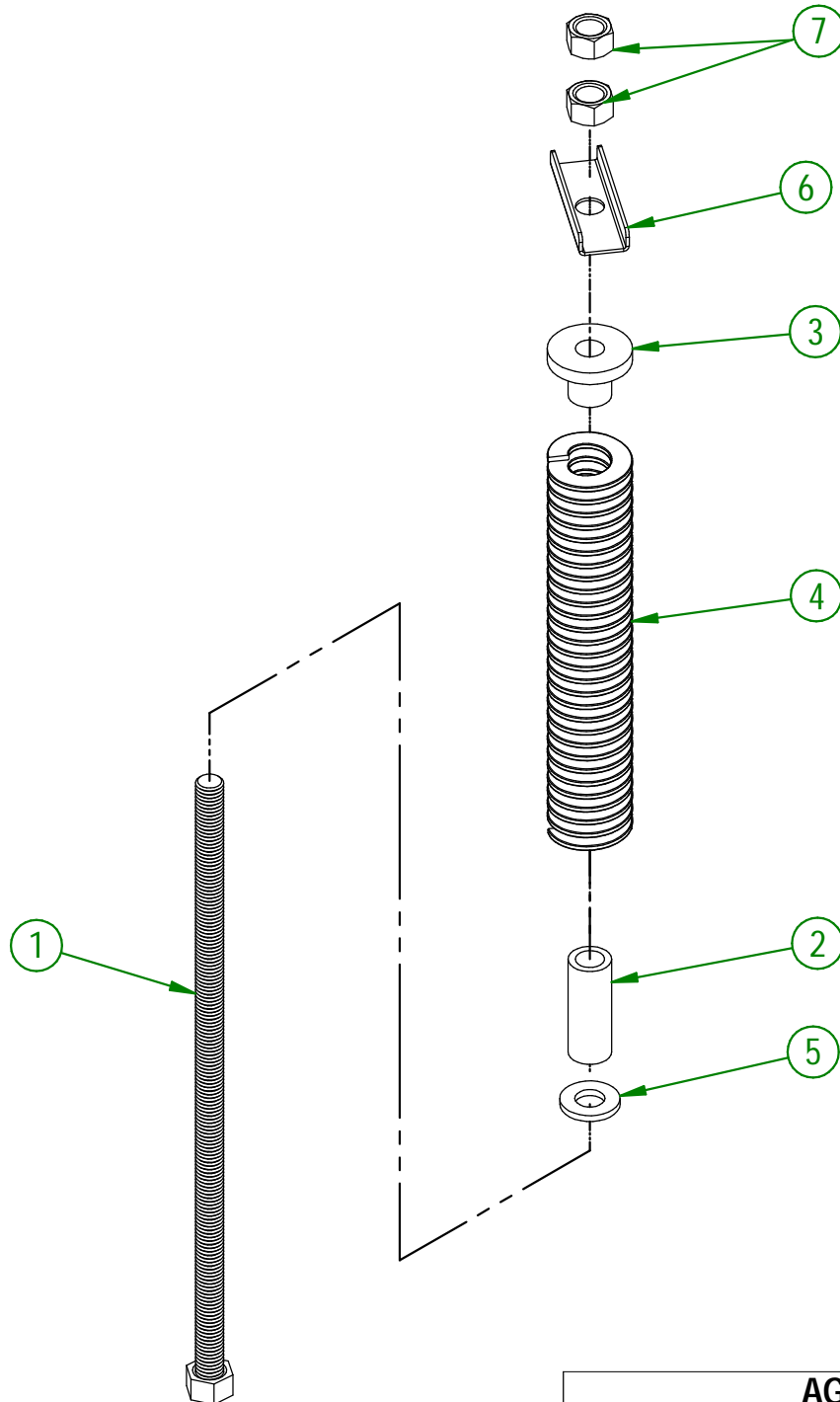

AGRIMETAL	
ASSEMBLY BELT TENSIONER	
CREATION : 2016-06-20	ASSEMBLY : 32-57-0040
REVISION : 2022-03-01	AUTHOR : F.H.

32-57-5005

#	PART #	Qty	TITLE
1	NC14-75-0024	1	FLANGE BEARING 4 HOLES UCF207-20 1 1/4" DIA.
2	NC01-17-0249	4	HEX. BOLT GR2 ZINC 1/2-13 X 1 1/2"
3	32-57-5000	1	IMPELLER
4	NC02-32-0014	4	LOCK WASHER ZINC 1/2"
5	NC02-07-0020	4	HEX. NUT ZINC 1/2-13
6	NC14-75-0023	1	FLANGE BEARING 4 HOLES UCF205-16 1" ID
7	23-01-3600	1	BEARING GUARD
8	NC01-17-0183	4	BOLT HEX. GR2 ZINC 7/16-14 X 1 1/2"
9	NC02-25-0011	4	WASHER SAE ZINC 17/32 ID
10	NC02-32-0013	4	LOCK WASHER ZINC 0.4375 = 7/16
11	NC02-07-0019	4	NUT HEX. ZINC 7/16-14
12	NC14-62-0016	1	QD BUSHING SH 1 1/4"
13	NC14-62-0135	1	PULLEY QD 2V 1/2-5/8 X 3.95 OD X SH
14	01-41-0910	1	KEY
15	NC01-64-0016	1	RETAINING RING 1 1/4"

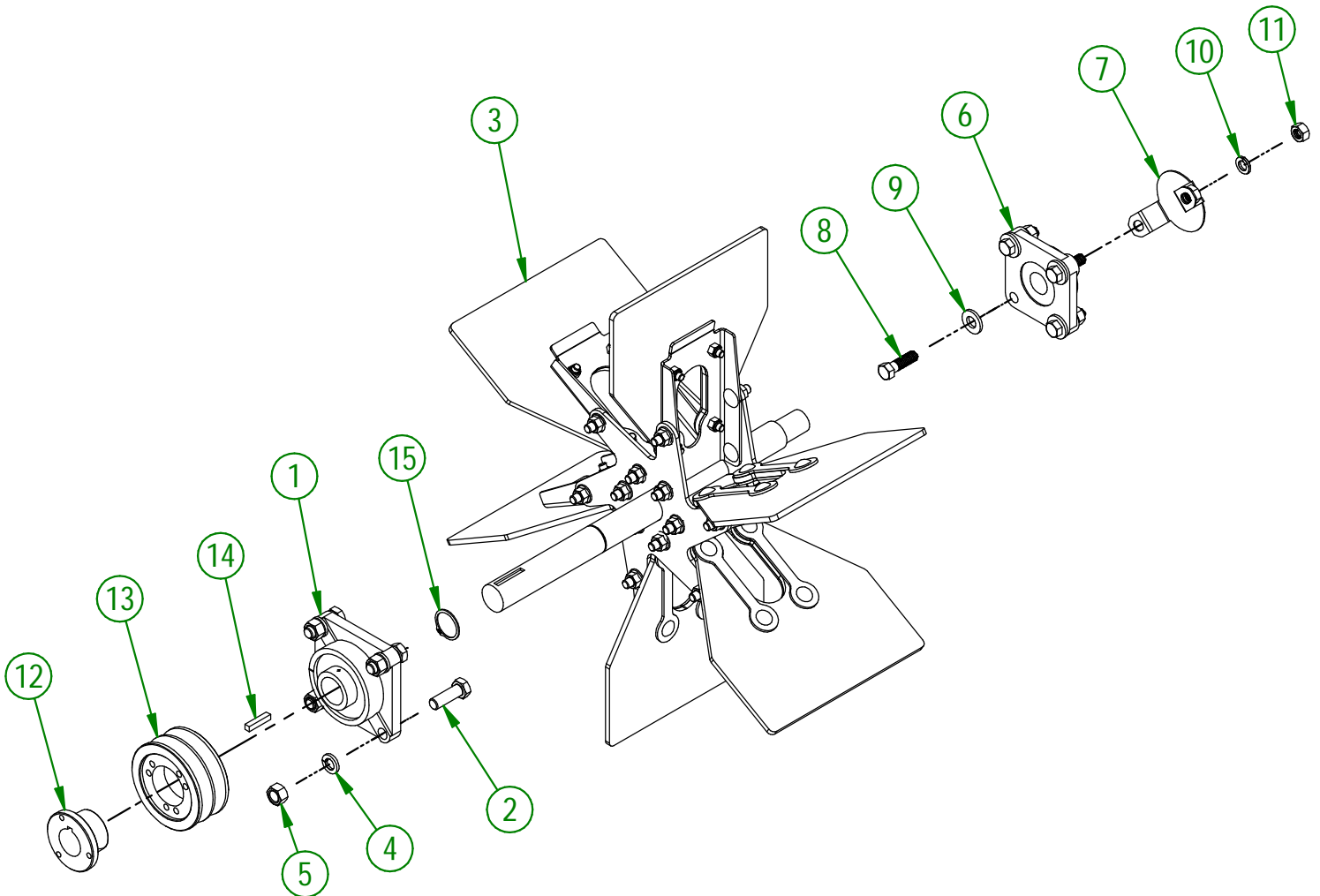

USE THESE PIECES ONLY IF YOUR SERIAL NUMBER IS AFFECTED:

#45583 AND UNDER

AGRIMETAL	
ASSEMBLY IMPELLER	
CREATION : 16/06/22	ASSEMBLY : 32-57-5005
REVISION : 12/04/24	AUTHOR : J. Houle

32-57-5000

#	PART #	Qty	TITLE
1	32-50-5000	1	IMPELLER
2	NC17-14-0015	6	IMPELLER PADDLE
3	32-01-0000	12	PADDLE BRACE
4	NC01-04-0058	24	CARRAGE BOLT 5/16-18 X 1"
5	NC01-96-0010	24	NYLON NUT HEX. ZINC 5/16-18

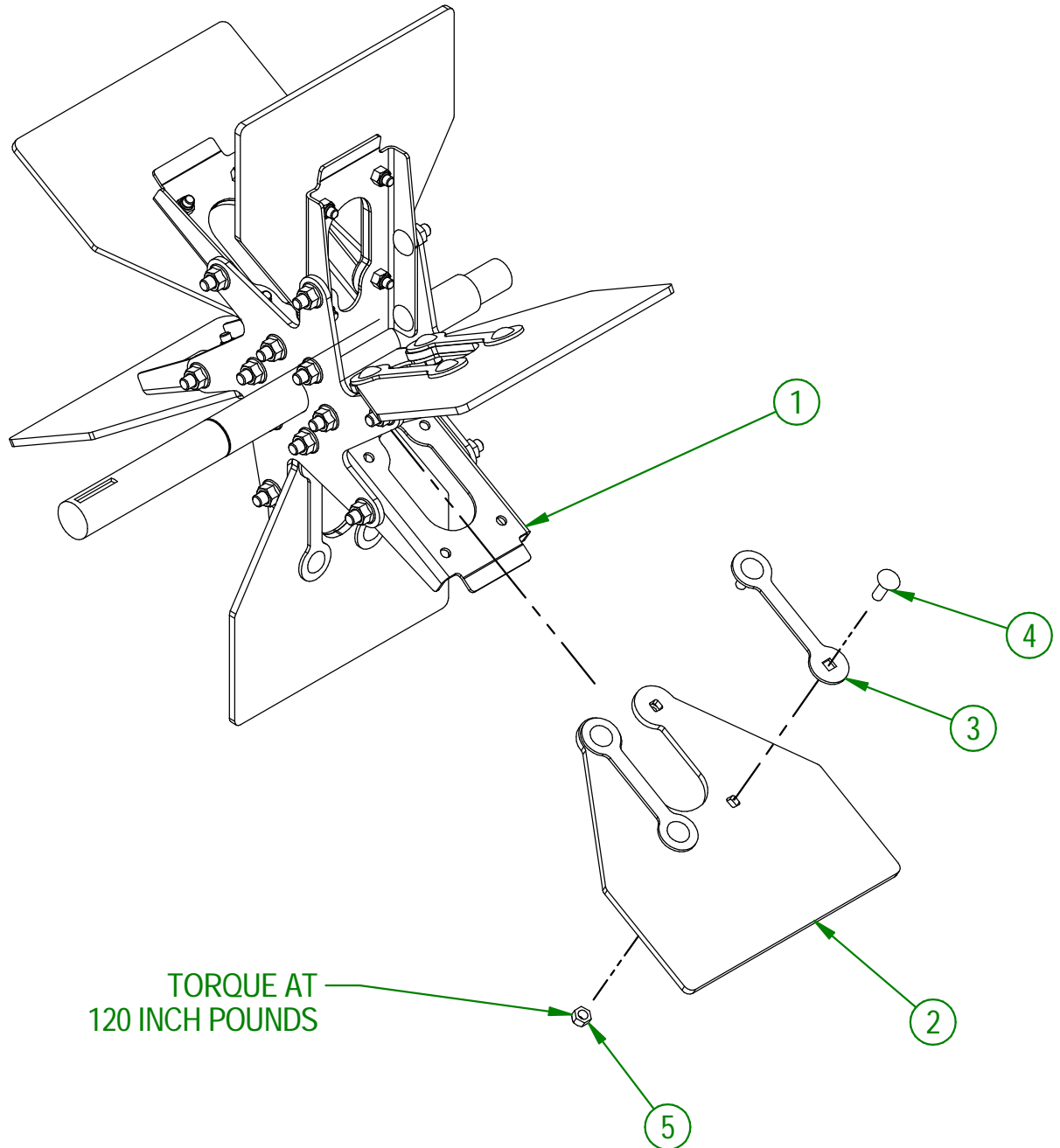

USE THESE PIECES ONLY IF YOUR SERIAL NUMBER IS AFFECTED:

#45583 AND UNDER

AGRIMETAL	
IMPELLER	
CREATION : 16/06/22	ASSEMBLY : 32-57-5000
REVISION : 12/04/24	AUTHOR : J. Houle

#	PART #	Qty	TITLE
1	12-38-0001	1	FLANGE BEARING UCF 207-20
2	NC01-17-0249	4	HEX. BOLT GR2 ZINC 1/2-13 X 1 1/2"
3	32-57-5001	1	IMPELLER
4	NC02-32-0014	4	LOCK WASHER ZINC 1/2"
5	NC02-07-0020	4	HEX. NUT ZINC 1/2-13
6	32-38-0025	1	FLANGE BEARING 4 HOLES UFC205-16 1" ID
7	23-01-3600	1	BEARING GUARD
8	NC01-17-0183	4	BOLT HEX. GR2 ZINC 7/16-14 X 1 1/2"
9	NC02-25-0011	4	WASHER SAE ZINC 17/32 ID
10	NC02-32-0013	4	LOCK WASHER ZINC 0.4375 = 7/16
11	NC02-07-0019	4	NUT HEX. ZINC 7/16-14
12	NC14-62-0016	1	QD BUSHING SH 1 1/4"
13	NC14-62-0135	1	PULLEY QD 2V 1/2-5/8 X 3.95 OD X SH
14	01-41-0910	1	KEY
15	NC01-64-0016	1	RETAINING RING 1 1/4"

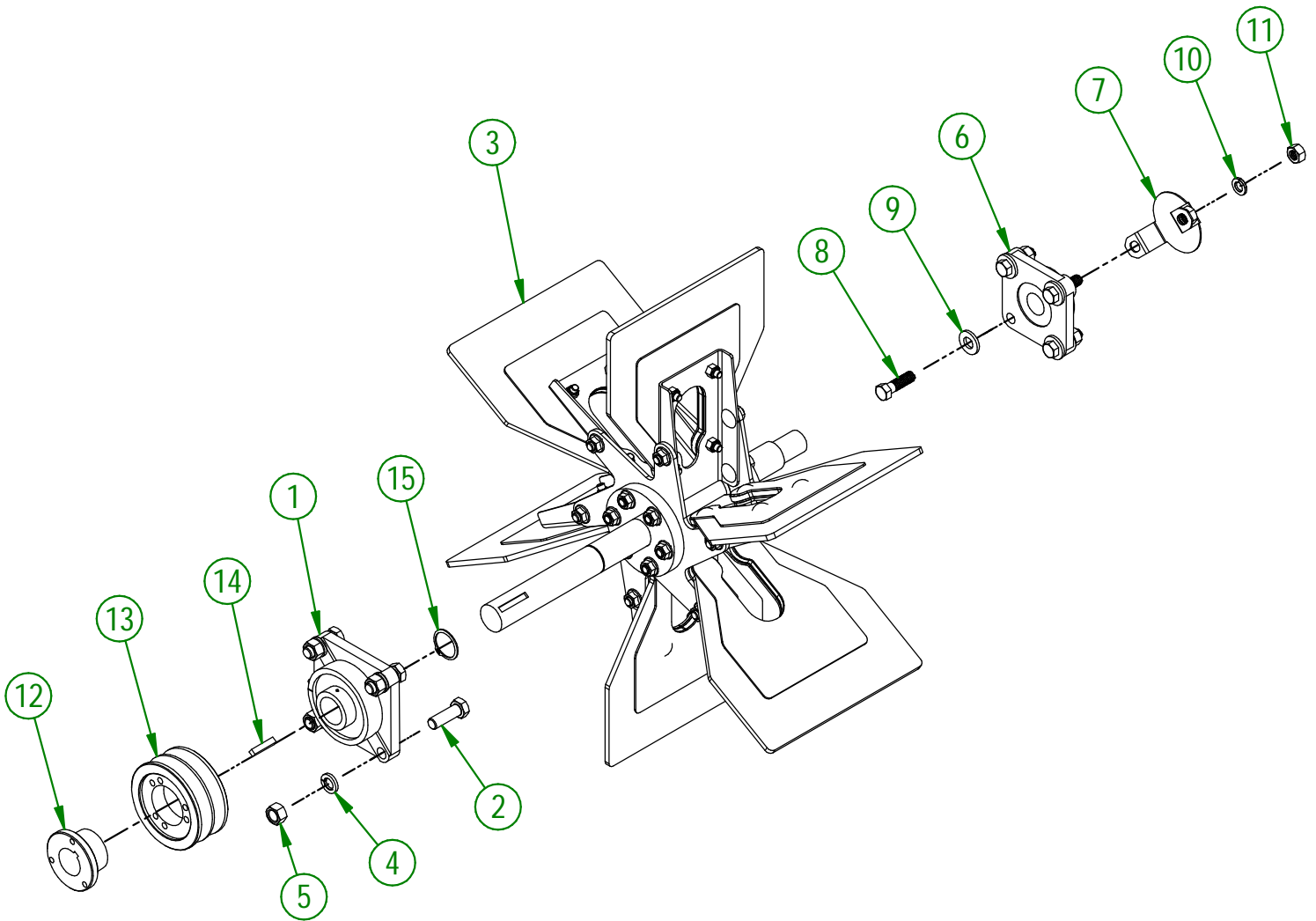

USE THESE PIECES ONLY IF YOUR SERIAL NUMBER IS AFFECTED:

#45584 AND ABOVE

AGRIMETAL	
ASSEMBLY IMPELLER	
CREATION : 12/04/24	ASSEMBLY : 32-57-5006
REVISION : 05/01/26	AUTHOR : J. Houle

32-57-5001

#	PART #	Qty	TITLE
1	32-50-5001	1	IMPELLER
2	NC17-14-0015	6	IMPELLER PADDLE
3	32-01-0006	12	PADDLE BRACE
4	NC01-04-0058	24	CARRAGE BOLT 5/16-18 X 1"
5	NC01-96-0010	24	NYLON NUT HEX. ZINC 5/16-18

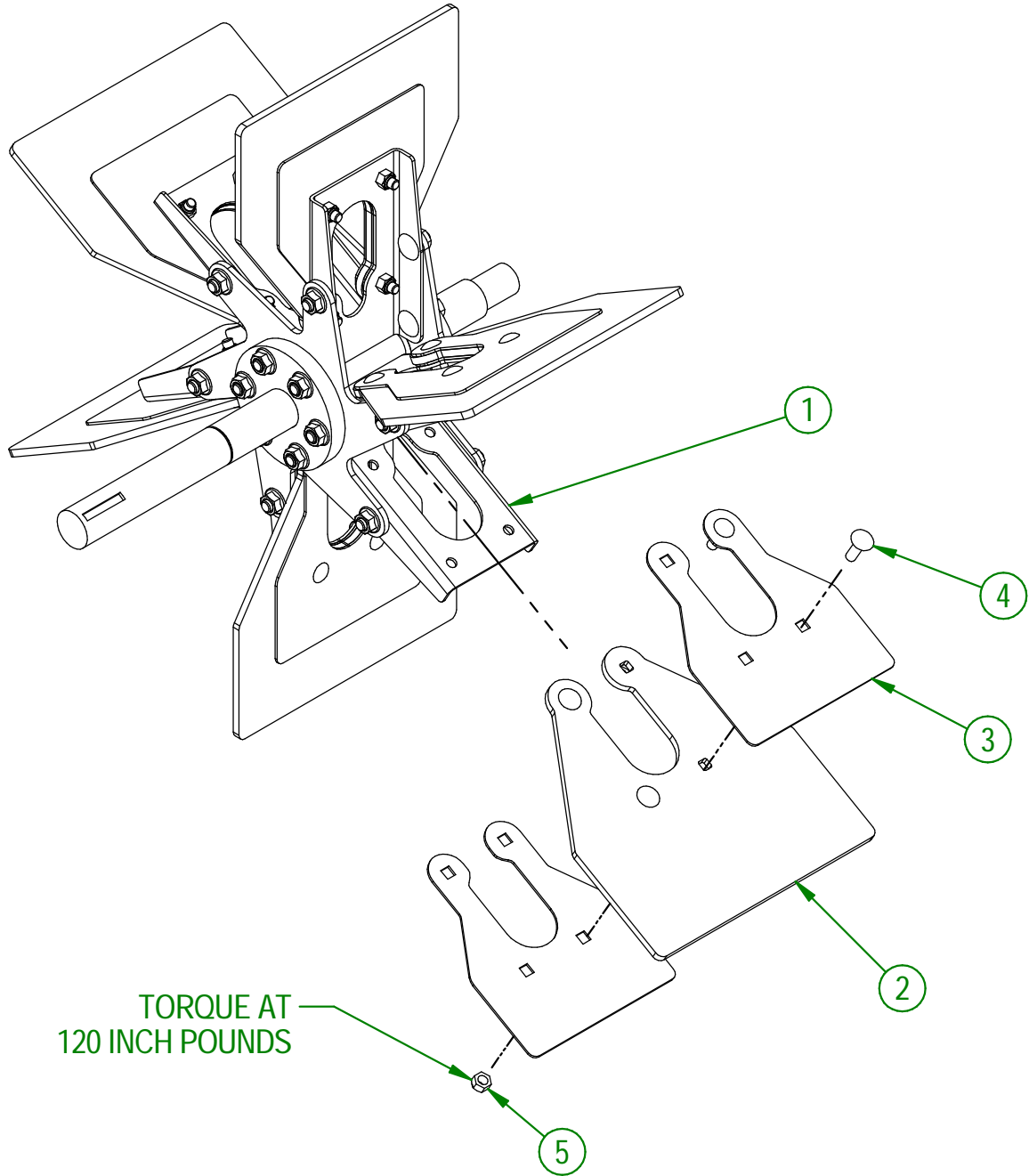

USE THESE PIECES ONLY IF YOUR SERIAL
NUMBER IS AFFECTED:

#45584 AND ABOVE

AGRIMETAL	
IMPELLER	
CREATION : 12/04/24	ASSEMBLY : 32-57-5001
REVISION : 12/04/24	AUTHOR : J. Houle

32-57-5035

#	PART #	Qty	TITLE
1	32-57-5040	1	ASSEMBLY COVER CASING
2	NC01-04-0107	8	CARR. BOLT GR2 ZINC 3/8-16 X 3/4"
3	NC02-14-0019	10	FLANGE NUT HEX. NC 3/8-16 GR. B

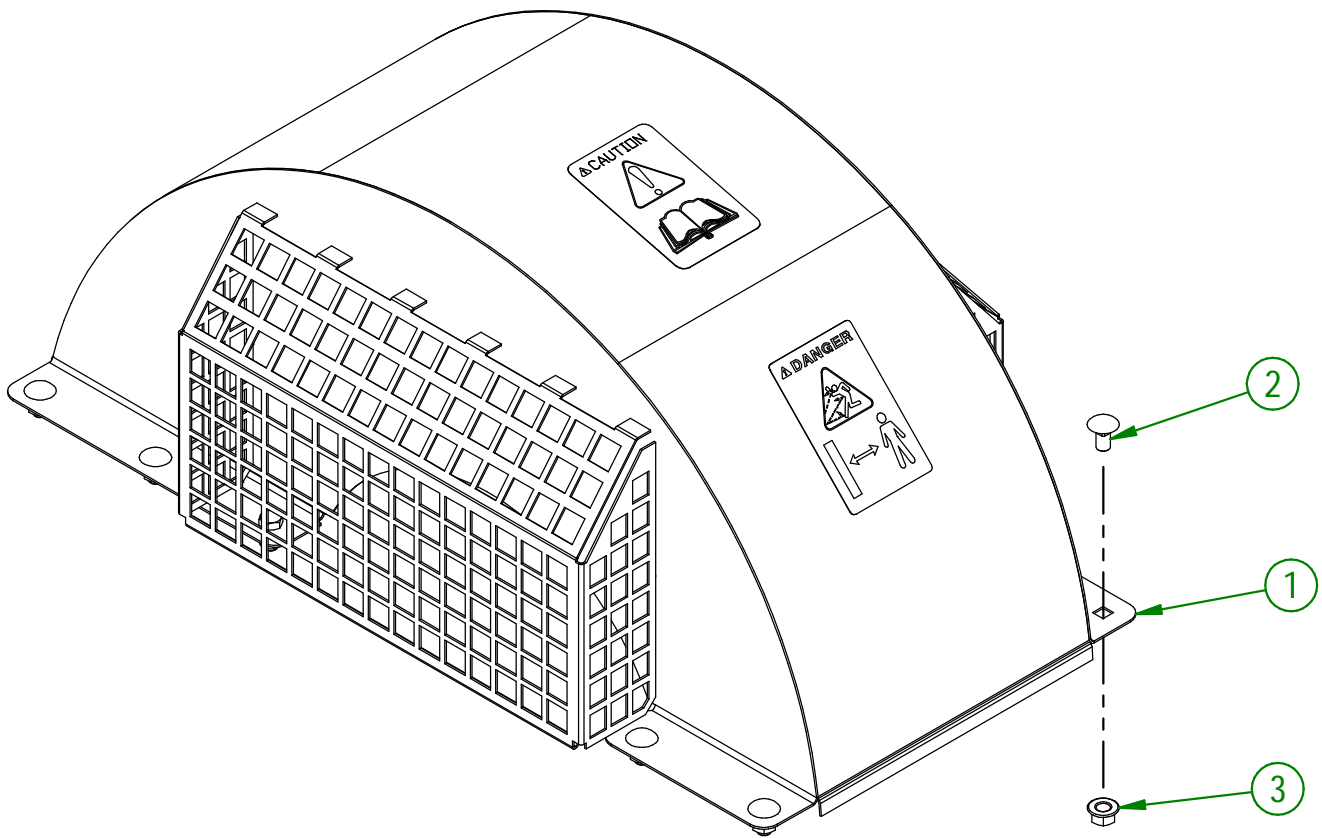

AGRIMETAL	
ASSEMBLY COVER CASING	
CREATION : 16/06/22	ASSEMBLY : 32-57-5035
REVISION : 16/06/22	AUTHOR : J. Houle

32-57-0105

#	PART #	Qty	TITLE
1	NC13-30-0237	1	PLASTIC TUBE FOR OPERATOR'S MANUAL
2	NC02-25-0007	3	WASHER ZINC 0.281 = 9/32
3	NC01-96-0009	3	NYLON-INSERT LOCKNUT ZINC 1/4-20
4	NC01-04-0003	3	CARR. BOLT GR2 ZINC 1/4-20 X 3/4"
5	32-98-0620	1	OPER. MAN BW 1600 3 POINTS

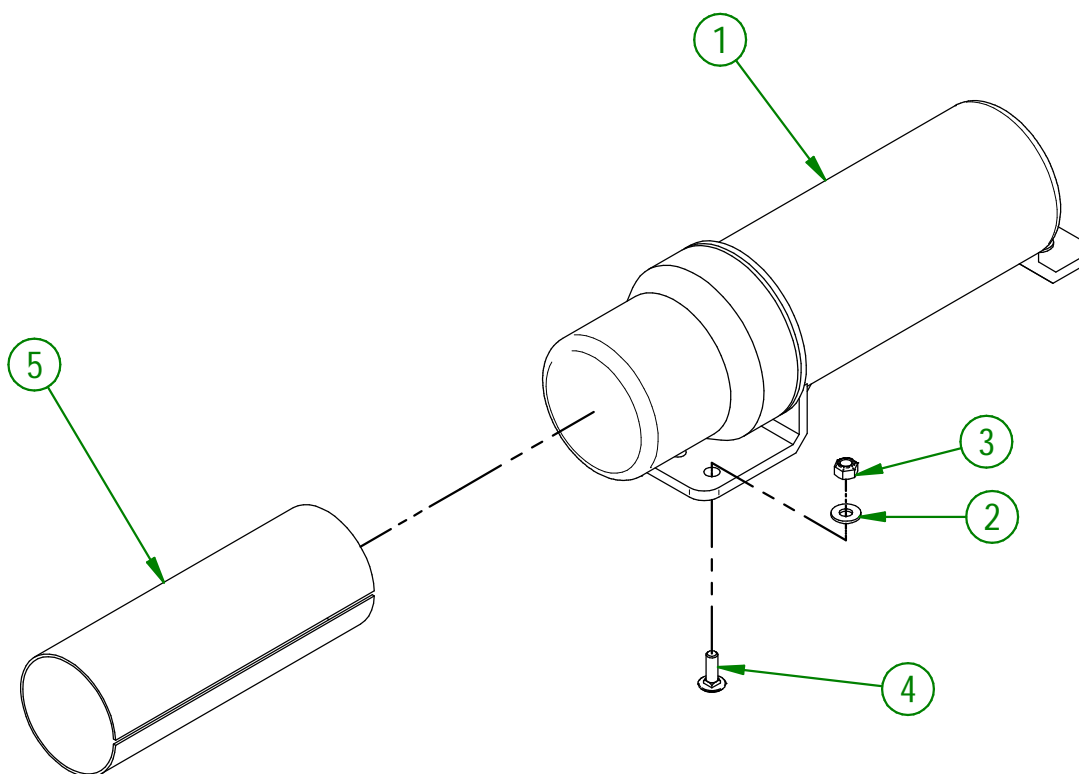

AGRIMETAL	
OPERATOR MANUEL	
CREATION : 07/02/17	ASSEMBLY : 32-57-0105
REVISION : 16/06/22	AUTHOR : F.HÉLIE

#	PART #	QTY	TITLE
1	NCI3-33-2654	2	STICKER B-16
2	NCI3-33-0024	6	STICKER GREASE HERE
3	NCI3-33-0035	2	STICKER AGRIMETAL
4	NCI3-33-0163	1	STICKER LOW DECIBEL
5	NCI3-33-0186	1	STICKER (DANGER)
6	NCI3-33-0290	1	STICKER DANGER
7	NCI3-33-0306	1	STICKER 77 DB
8	NCI3-33-0192	2	STICKER (PROJECTION RISK)
9	NCI3-33-0183	1	STICKER CAUTION OPERATION MANUAL
10	NCI3-33-0287	1	STICKER WARNING
11	NCI3-33-0179	1	STICKER IMPORTANT GREASE DRIVE LINE
12	NCI3-33-0298	2	STICKER PULL THIS WAY TO OPEN
13	NCI3-33-0005	1	STICKER MAXIMUM 540 RPM
14	NCI3-33-0187	1	STICKER DANGER (PTO AND PERSON)
15	NCI3-33-2686	1	STICKER IMPORTANT
16	NCI3-33-0133	1	STICKER DUCT POSITION UP DOWN

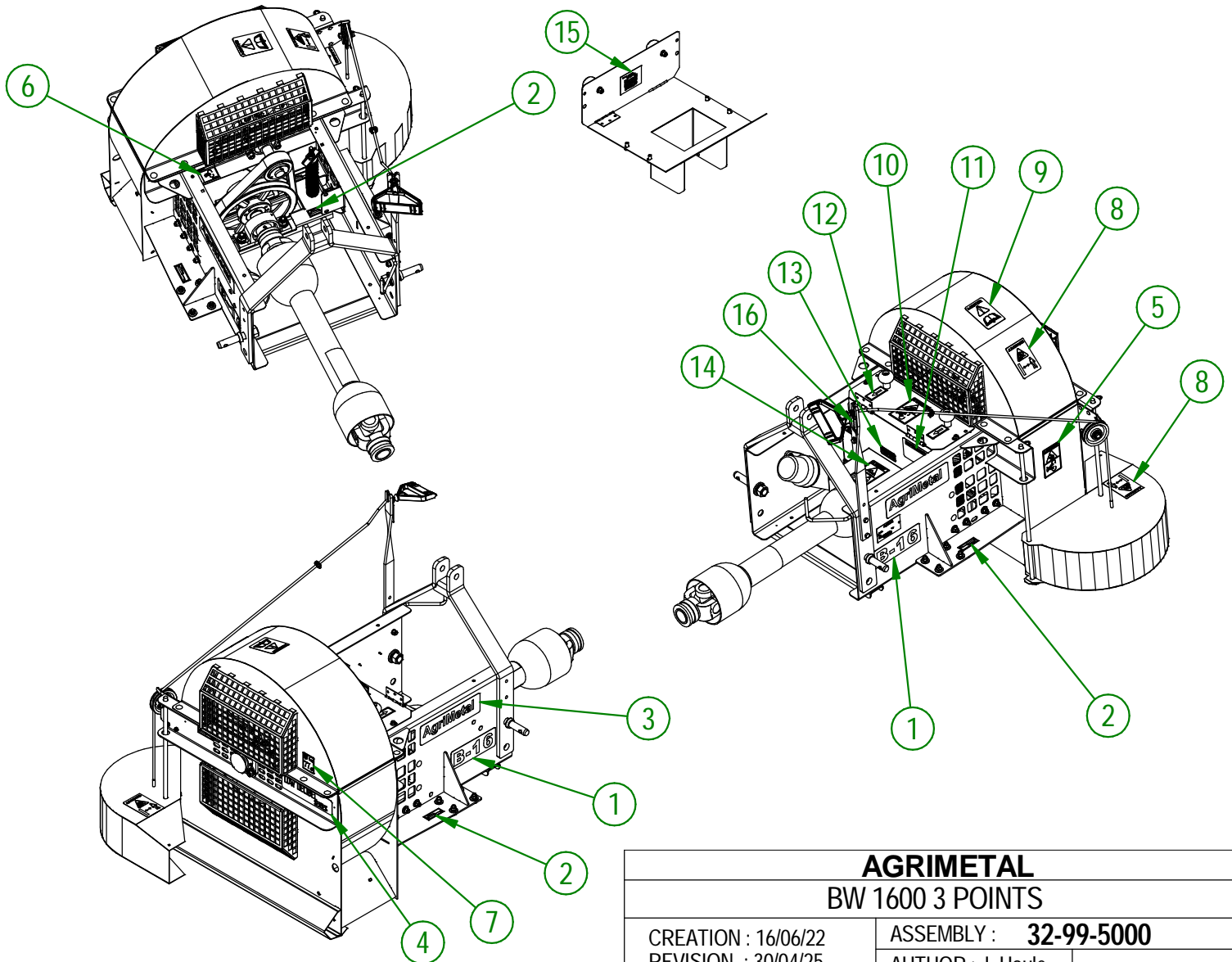

AGRIMETAL
BW 1600 3 POINTS

CREATION : 16/06/22
REVISION : 30/04/25

ASSEMBLY : **32-99-5000**
AUTHOR : J. Houle