

# AgriMetal

## PARTS LIST

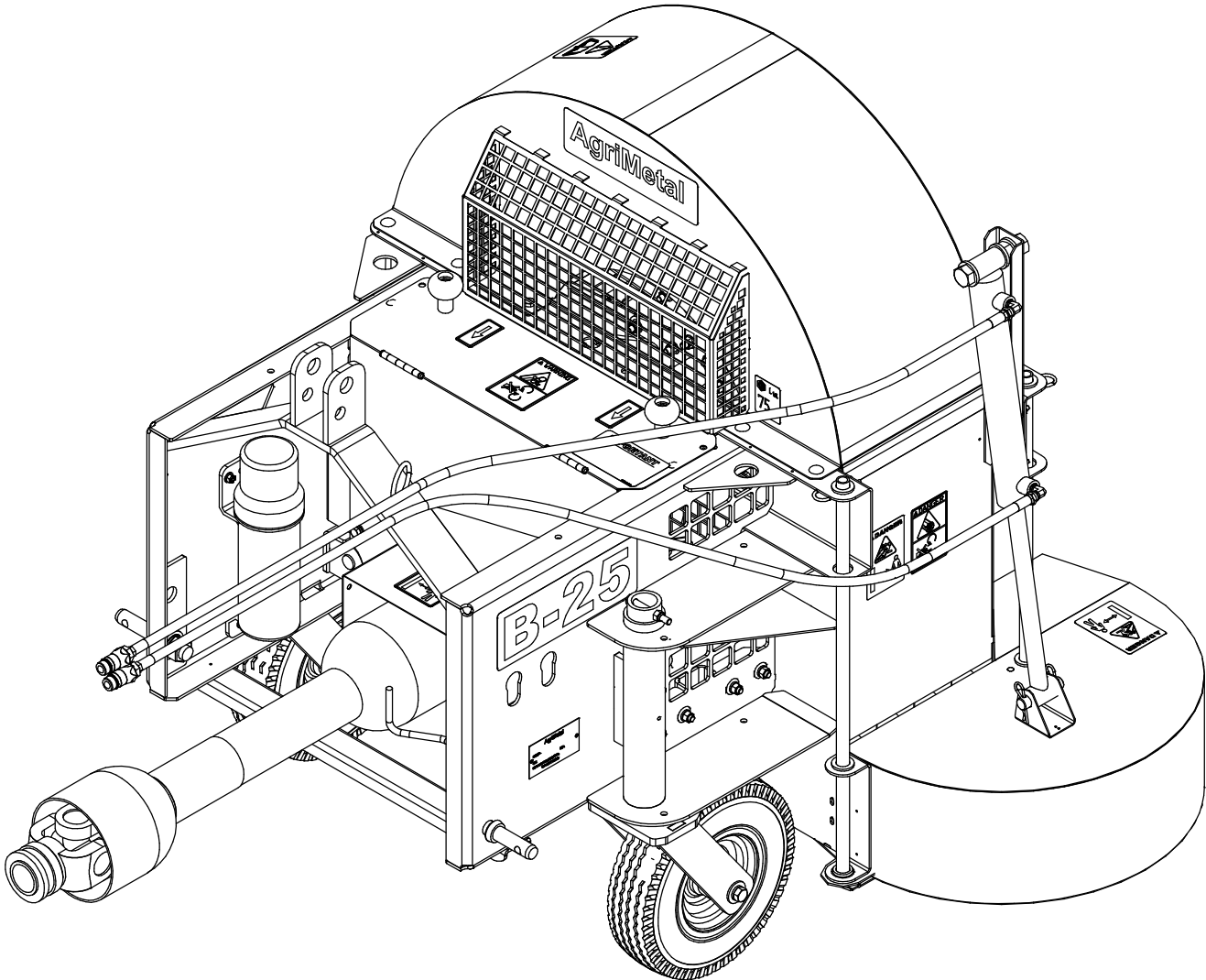

**B-25W**

32-57-3011

#	# DE PIÈCE	QTÉ	TITRE
1	32-50-3001	1	BOITIER DE SOUFFLEUR (B-25 3 POINTS)
2	NC17-46-0023	4	BAGUE DE GLISSIÈRE (0.810" ID X 1.310" OD X 0.460" LG)
3	25-55-0710	1	PLAQUE DE NO. DE SERIE

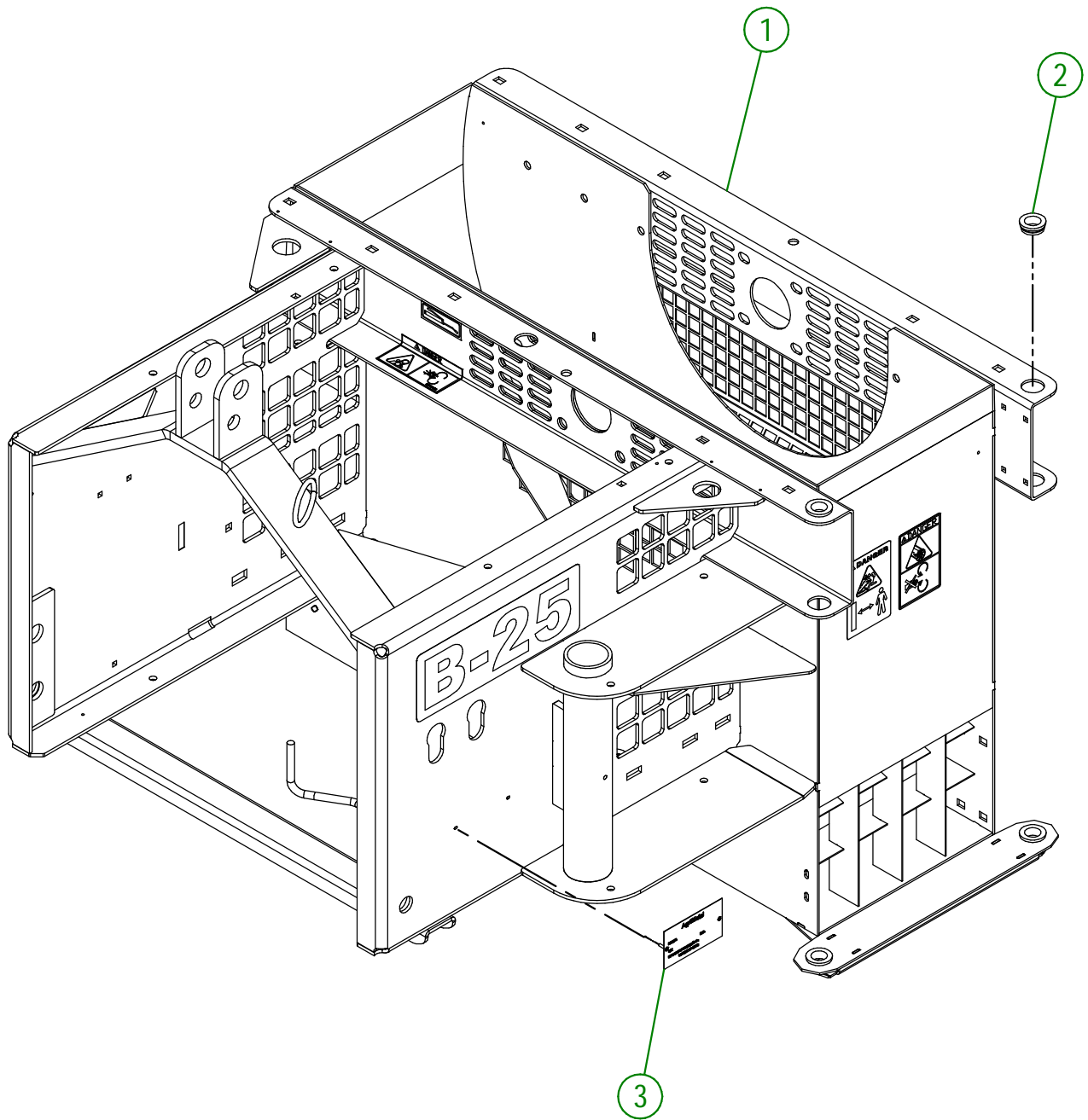

<b>AGRIMETAL</b>	
REGROUP. BOITIER DE SOUFFLEUR	
CREATION : 15/06/22	ASSEMBLY : <b>32-57-3011</b>
REVISION : 17/06/22	AUTHOR : J. Houle

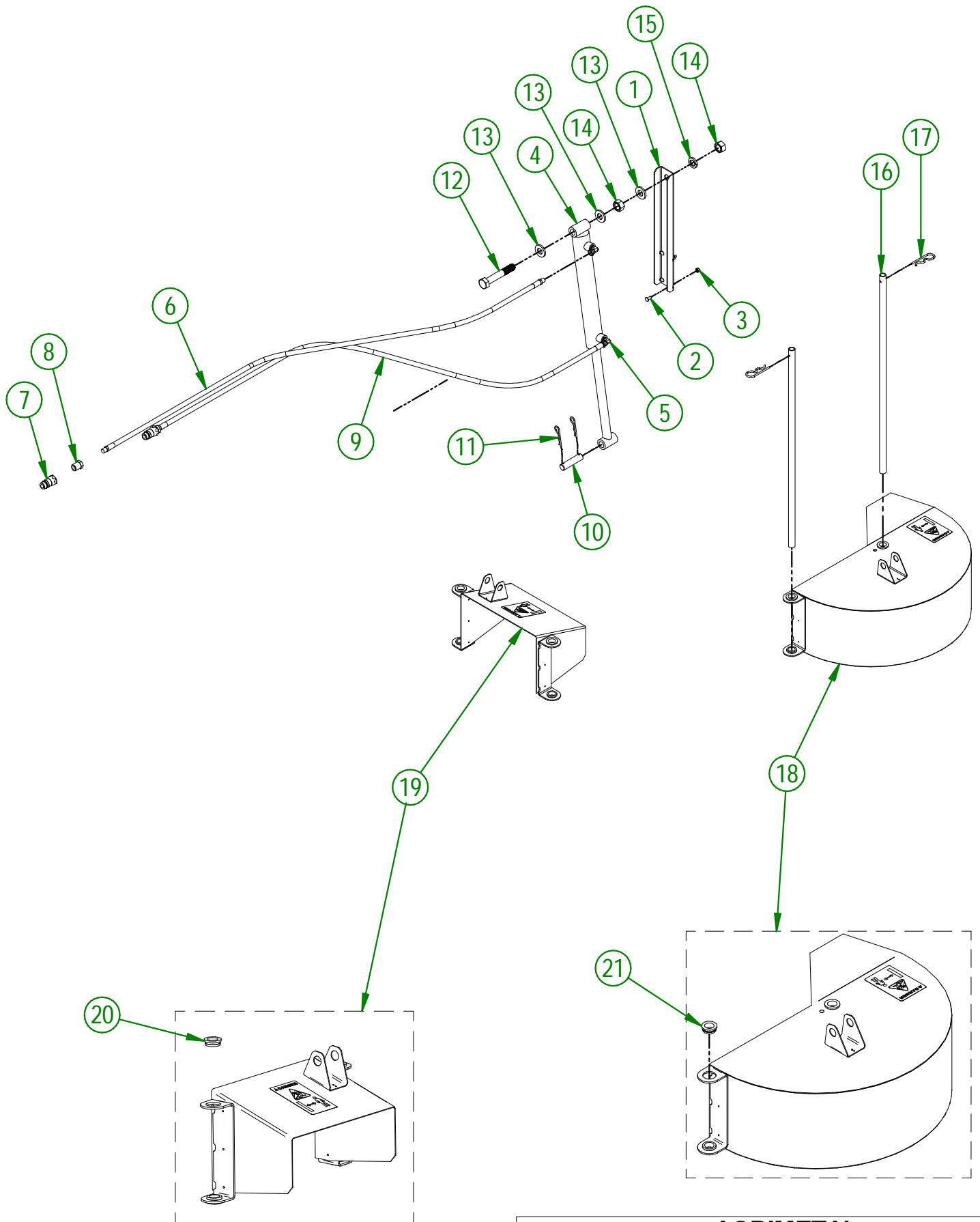

<b>AGRIMETAL</b>	
<b>HYDRAULIC DEFLECTOR 1° TO 180° (OPTION)</b>	
CREATION : 26/01/18	ASSEMBLY : <b>32-57-3000</b>
REVISION : 15/06/22	AUTHOR : F.HÉLIE

## 32-57-3000

#	PART #	Qty	TITLE
1	32-01-7565	1	CYLINDER BRACKET
2	NC01-04-0002	4	CARR. BOLT GR2 ZINC 1/4-20 X 5/8"
3	NC01-96-0009	4	NYLON-INSERT LOCKNUT ZINC 1/4-20
4	NC13-45-0148	1	HYDRAULIC CYL. 2" OD X 1" ROD X 18" OPEN X 10" TRAVEL
5	NC13-45-0026	2	90° Elbow - 7/16-20 MALE SAE 4 O-RINGS X 1/4 FEM.
6	NC17-02-0319	1	HYD. PIPE BOYAU HYD. 1/4" X 84 " CUT 1/4 NPT MALE RIG. X 1/4 NPT MALE RIG.
7	NC13-45-0014	2	QUICK COUPLER 1/2-14 NPTF
8	NC13-45-0153	2	HEX. REDUCER 1/4 NPT X 1/2 NPT
9	NC17-02-0319	1	HYD. PIPE BOYAU HYD. 1/4" X 84 " CUT 1/4 NPT MALE RIG. X 1/4 NPT MALE RIG.
10	32-21-0015	1	CYLINDER PIN
11	NC01-63-0015	2	COTTER PIN Z 1/8" X 2 5/8"
12	NC01-17-0478	1	BOLT HEX. GR2 ZINC 3/4-10 X 4 1/2"
13	22-04-6805	3	FLAT WASHER BEARING BASE
14	NC02-07-0023	2	HEX. NUT ZINC 3/4-10
15	NC02-32-0017	1	LOCK WASHER ZINC 3/4"
16	32-11-2505	2	DEFLECTOR GUIDE
17	NC01-63-0026	2	COTTER PIN ZC 5/32" X 3"
18	32-55-3075	1	ASSEMBLY DEFLECTOR
19	32-55-3080	1	ASSEMBLY SMALL DEFLECTOR (OPTION)

## 32-55-3080

#	PART #	QTY	TITLE
20	NC17-46-0023	4	BUSHING 0.810" ID X 1.310" OD X 0.460"

## 32-55-3075

#	PART #	QTY	TITLE
21	NC17-46-0023	4	BUSHING 0.810" ID X 1.310" OD X 0.460"

32-57-1507

#	PART #	Qty	TITLE
1	32-57-1512	1	ASSEMBLY PIVOT WHEEL SUPPORT
2	NC14-70-0024	1	WHEEL 12"
3	04-42-0135	2	WHEELS BUSHING
4	12-13-1405	1	AXEL PIVOT WHEEL
5	NC01-17-0247	2	HEX. BOLT GR2 ZINC 1/2-13 X 1"
6	NC02-32-0014	2	LOCK WASHER ZINC 1/2"
7	NC02-22-0012	2	WASHER ZINC 1/2 BOLT = 9/16"Ø X 1 3/8" OD
8	NC01-17-0122	1	HEX. BOLT GR2 ZINC 3/8-16 X 3"
9	NC01-96-0011	1	NYLON NUT 3/8-16

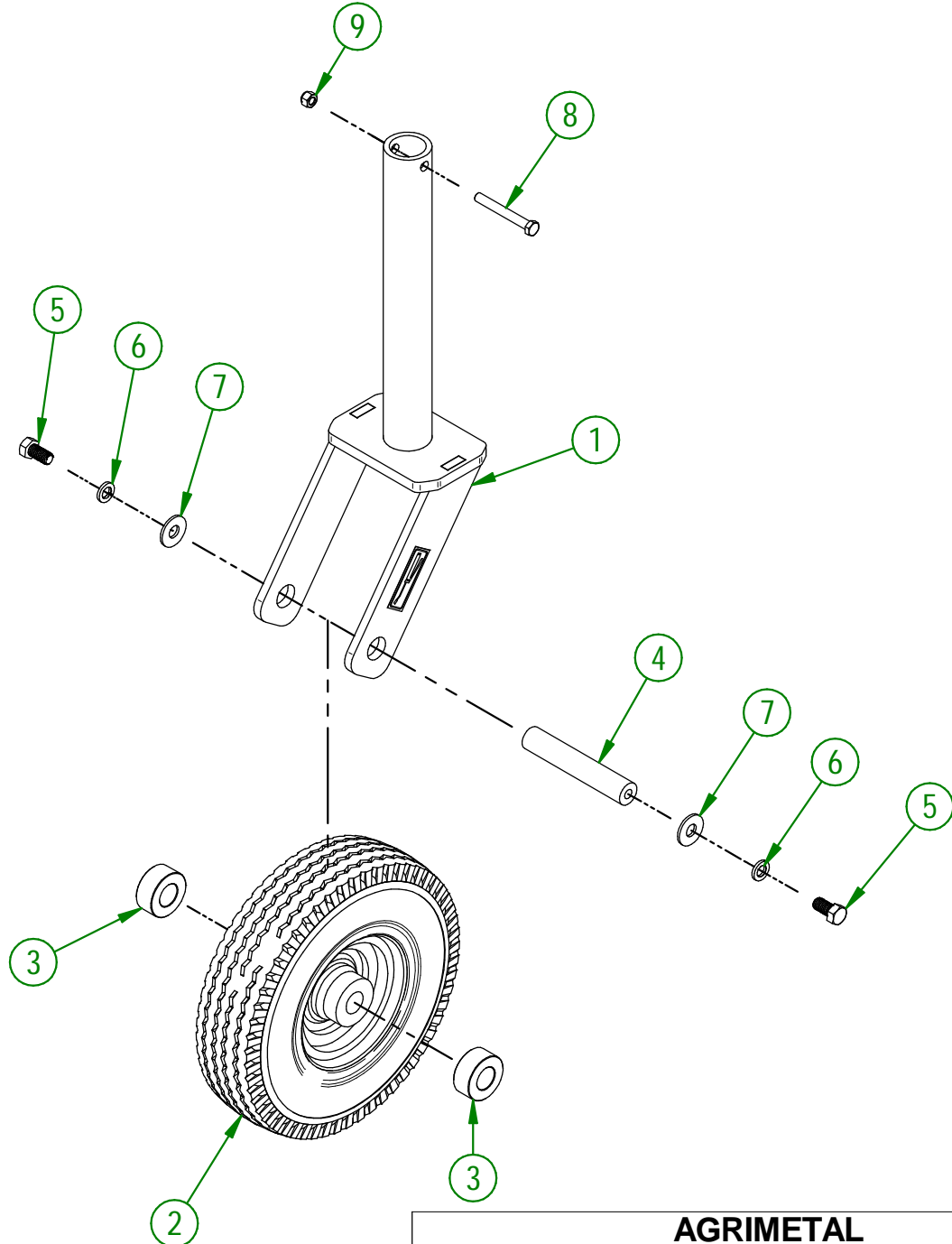

<b>AGRIMETAL</b>	
<b>ASSEMBLY WHEEL AND SUPPORT</b>	
CREATION : 15/06/22	ASSEMBLY : <b>32-57-1507</b>
REVISION : 15/06/22	AUTHOR : J. Houle

32-57-3060

#	PART #	Qty	TITLE
1	32-55-3070	1	ASSEMBLY SMALL TURF ROLLER
2	32-50-1056	1	LEFT SMALL TURF ROLLER SUPPORT
3	32-50-1061	1	RIGHT SMALL TURF ROLLER SUPPORT
4	NC01-04-0107	8	CARR. BOLT GR2 ZINC 3/8-16 X 3/4"
5	NC02-14-0019	8	FLANGE NUT HEX. NC 3/8-16 GR. B

32-55-3070

#	PART #	Qty	TITLE
6	32-11-3520	1	TURF ROLLER ONLY (REAR)
7	32-42-0105	2	REAR ROLL CAP

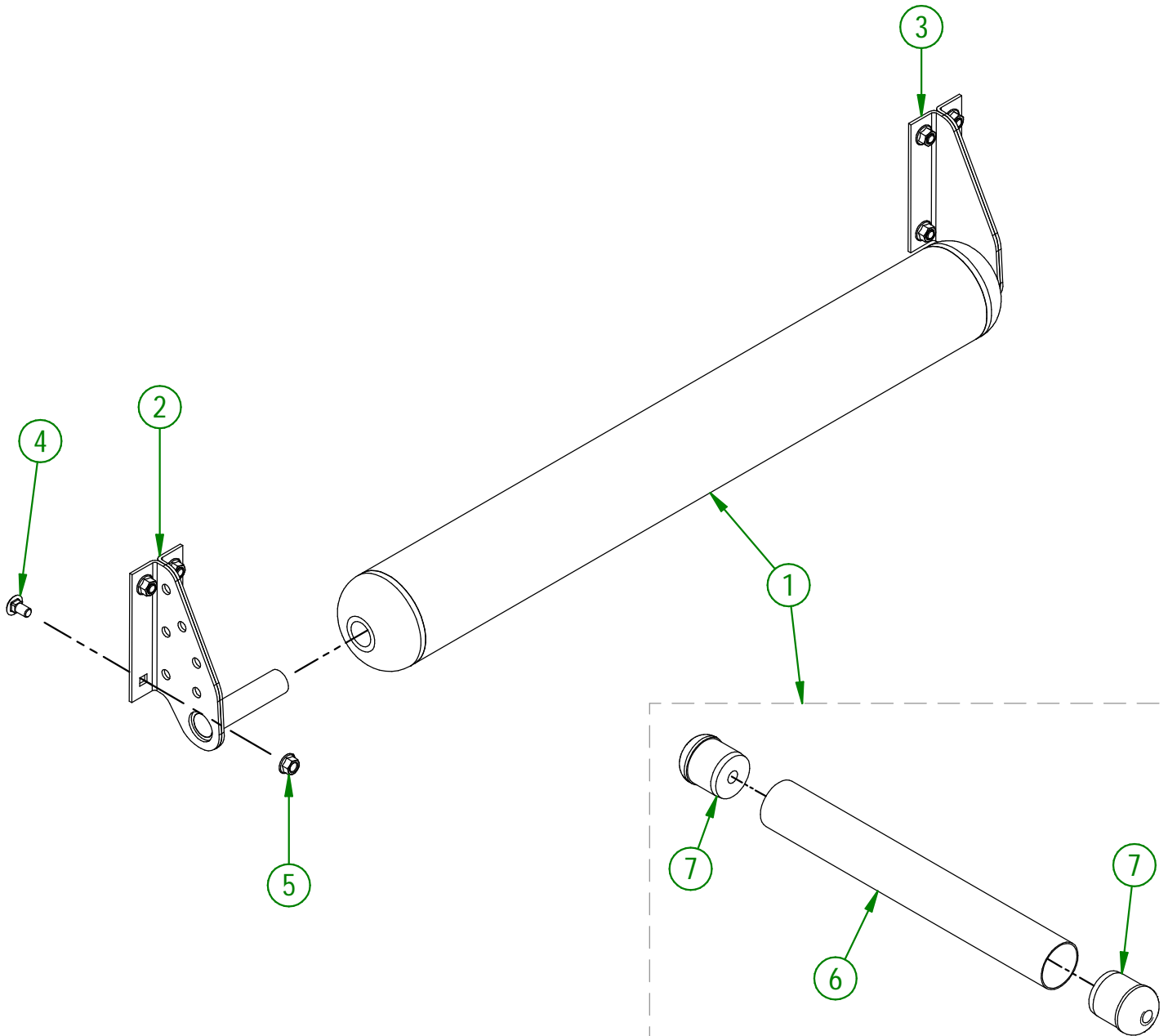

<b>AGRIMETAL</b>	
<b>ASSEMBLY SMALL TURF ROLLER</b>	
CREATION : 15/06/22	ASSEMBLY : <b>32-57-3060</b>
REVISION : 15/06/22	AUTHOR : J. Houle

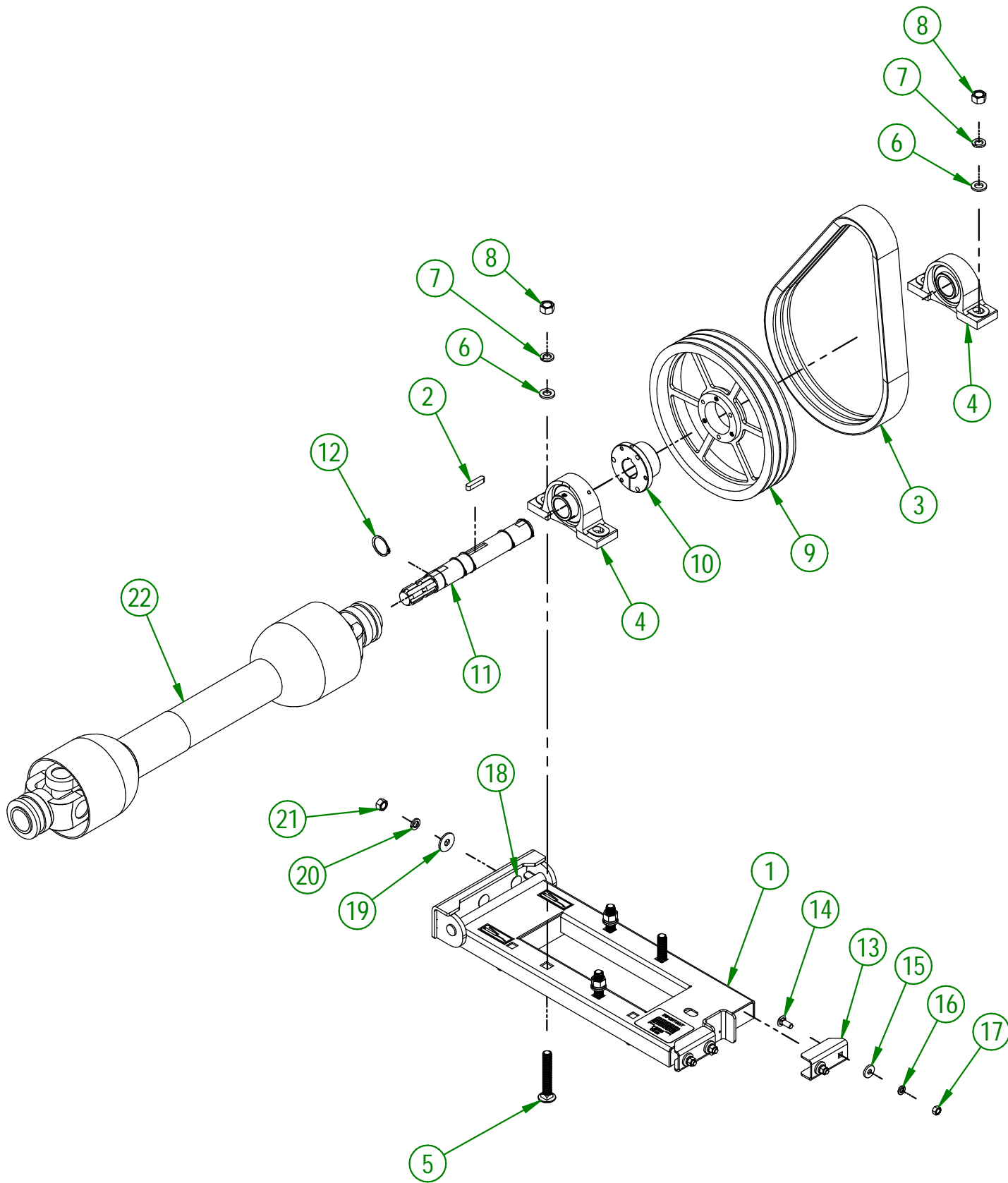

**AGRIMETAL**  
**BEARING BASE GROUP**

CREATION : 16/06/22  
 REVISION : 05/04/24

ASSEMBLY : **32-57-3036**  
 AUTHOR : J. Houle

## 32-57-3036

#	PART #	Qty	TITLE
1	32-57-3021	1	ASSEMBLY BEARING BASE
2	NC01-65-0100	1	KEY 3/8 X 3/8 X 1 3/4"
3	NC14-25-3377	1	TRIPLE V BELT 21/32 COGGED RAW EDGE BX-49
4	NC14-75-0035	2	PILLOW BLOCK SUPPORT UCP208-24 $\phi$ 1 1/2"
5	NC01-04-0276	4	BOLT CARR. GR2 ZINC 5/8-11 X 4"
6	32-01-1395	4	BEARING WHASER $\phi$ 3/4"
7	NC02-32-0016	4	LOCK WASHER ZINC 5/8"
8	NC02-07-0022	4	HEX. NUT ZINC 5/8-11
9	NC14-62-0138	1	PULLEY QD 3V 1/2-5/8 X 12.75 OD X SK
10	NC14-62-0021	1	QD BUSHING SK 1 1/2"
11	32-20-0066	1	DRIVE SHAFT
12	NC01-64-0022	5	QD BUSHING
13	32-01-1125	2	BEARING BASE STOPPER
14	NC01-04-0109	4	CARR. BOLT GR2 ZINC 3/8-16 X 1"
15	21-01-0950	4	FLAT WASHER IOGA 1.005" DIA X 25/64"
16	NC02-32-0012	4	LOCK WASHER ZINC 3/8"
17	NC02-07-0018	4	HEX. NUT ZINC 3/8-16
18	NC01-04-0234	3	CARR. BOLT GR2 ZINC 1/2-13 X 1 1/4
19	01-01-1660	3	WASHER SPACER
20	NC02-32-0014	3	LOCK WASHER ZINC 1/2"
21	NC02-07-0020	3	HEX. NUT ZINC 1/2-13
22	32-34-0040	1	PTO T40 X 36.69"
23	NC13-25-0229	2	BLACK TIE RAP
24	NC13-50-0110	1	IMPORTANT/NOTICE PTO POSTER
25	NC13-25-0245	1	BLACK TIE RAP

32-57-3085

#	PART #	Qty	TITLE
1	NC17-46-0018	2	HANDLE KNOB
2	NC01-17-0119	2	HEX. BOLT GR2 ZINC 3/8-16 X 2 1/4"
3	01-01-2485	6	FLAT WASHER 14 GA X 13/16"OD X 25/64" ID
4	NC02-32-0012	6	LOCK WASHER ZINC 3/8"
5	NC02-07-0018	2	HEX. NUT ZINC 3/8-16
6	32-57-4105	1	BELT GUARD " STICKER INCLUDE"
7	NC01-17-0112	4	HEX. BOLT GR2 ZINC 3/8-16 X 3/4"
8	NC01-04-0055	2	CARR. BOLT GR2 ZINC 5/16-18 X 5/8"
9	NC01-96-0010	2	NYLON NUT HEX. ZINC 5/16-18

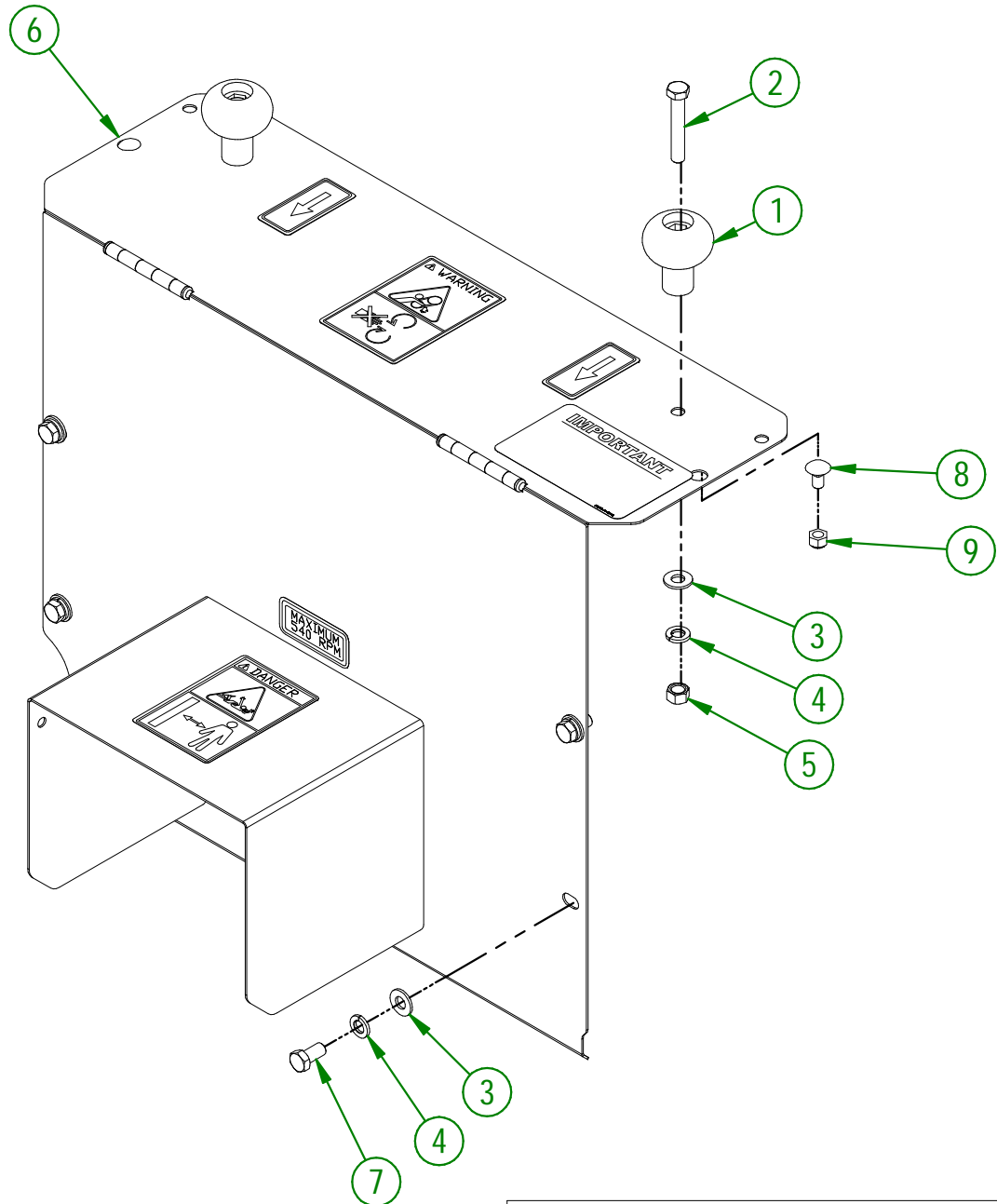

<b>AGRIMETAL</b>	
<b>ASSEMBLY BELT COVER</b>	
CREATION : 2016-06-21	ASSEMBLY : 32-57-3085
REVISION : 2022-06-16	AUTHOR :

32-57-3040

#	# DE PIÈCE	Qty	TITLE
1	32-50-3030	1	WELD ASSEMBLY THREADED ROD
2	NC02-22-0013	1	WASHER ZINC 5/8 ID X 1 1/2 OD
3	32-42-0135	1	SPRING GUIDE
4	12-44-0015	1	RED SPRING 1 1/2" OD 1" ID X 8 1/2"
5	32-42-0130	1	SPRING STOPPER
6	NC02-07-0022	2	HEX. NUT ZINC 5/8-11
7	32-01-3170	1	TENSIONER HANDLE

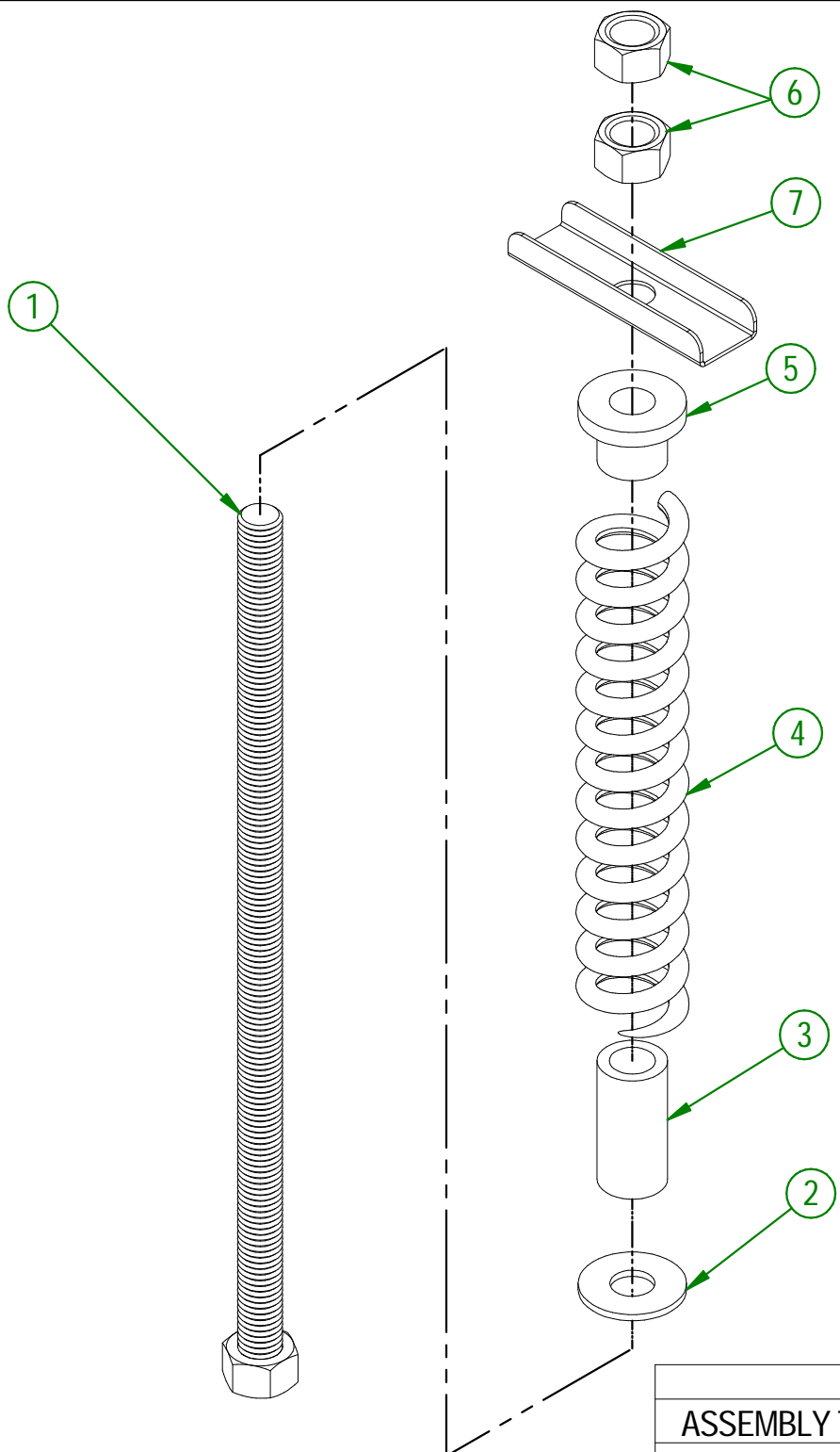

<b>AGRIMETAL</b>	
<b>ASSEMBLY TENSIONER</b>	
CREATION : 2016-06-21	ASSEMBLY : 32-57-3040
REVISION : 2022-06-16	AUTHOR : S.B.

32-57-6005

#	PART #	Qty	TITLE
1	NC14-75-0025	1	FLANGE BEARING 4 HOLES UCF 208-24 X 1 1/2"
2	NC01-17-0396	4	HEX. BOLT GR2 ZINC 5/8-11 X 2"
3	NC02-32-0016	4	LOCK WASHER ZINC 5/8"
4	NC02-07-0022	4	HEX. NUT ZINC 5/8-11
5	NC14-75-0024	1	FLANGE BEARING 4 HOLES UCF207-20 1 1/4" DIA.
6	12-01-3051	1	REAR BEARING PROTECTOR
7	NC01-17-0250	4	HEX. BOLT GR2 ZINC 1/2-13 X 1 3/4"
8	NC02-25-0011	4	WASHER SAE ZINC 17/32 ID
9	NC02-32-0014	4	LOCK WASHER ZINC 1/2"
10	NC02-07-0020	4	HEX. NUT ZINC 1/2-13
11	NC14-62-0198	1	PULLEY QD 3V 1/2-5/8 X 4.95 OD X SD (3B46)
12	NC14-62-0007	1	QD BUSHING SD 1 1/2"
13	12-41-0915	1	PULLEY KEY
14	32-57-6000	1	IMPELLER

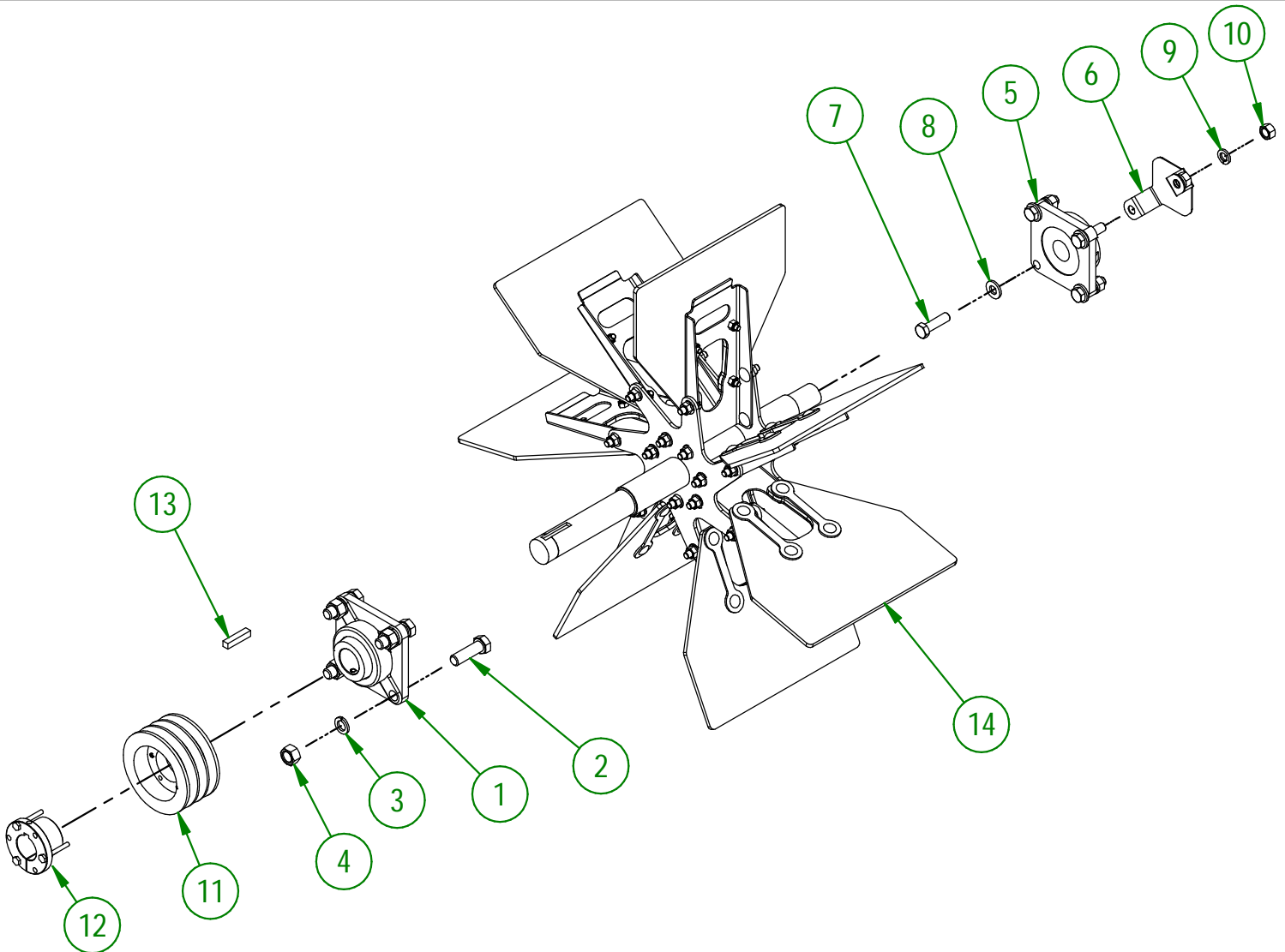

USE THESE PIECES ONLY IF YOUR SERIAL NUMBER IS AFFECTED:

BETWEEN #39536 AND #45452

**AGRIMETAL**  
ASSEMBLY IMPELLER

CREATION : 06/10/20  
REVISION : 26/03/24

ASSEMBLY : **32-57-6005**  
AUTHOR : J. Houle

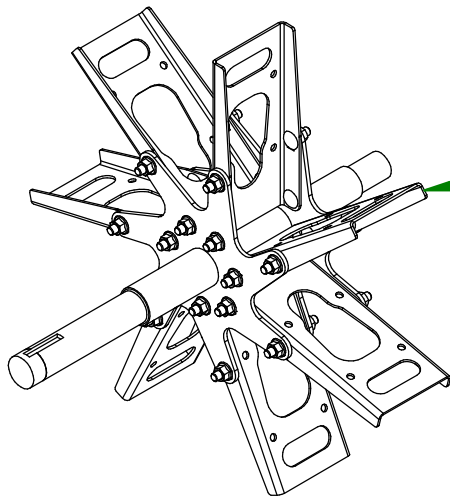

32-50-6000  
IMPELLER FRAME

32-57-6010  
IMPELLER PADDLE AND  
PADDLE REINFORCEMENT GROUP

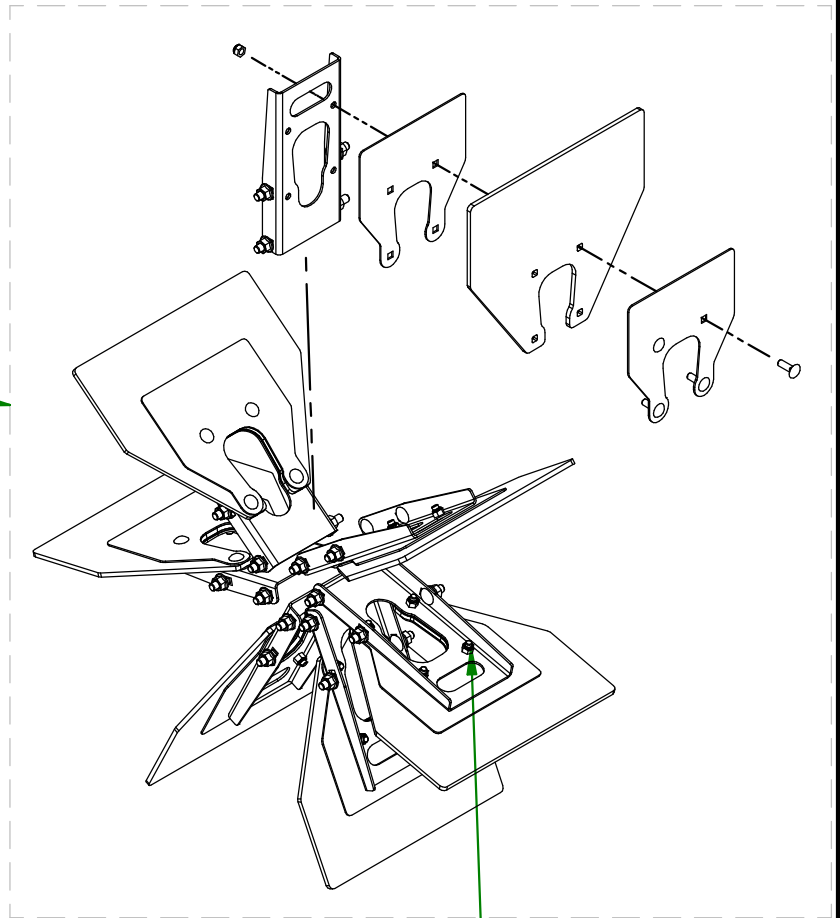

TORQUE AT  
120 INCH POUNDS

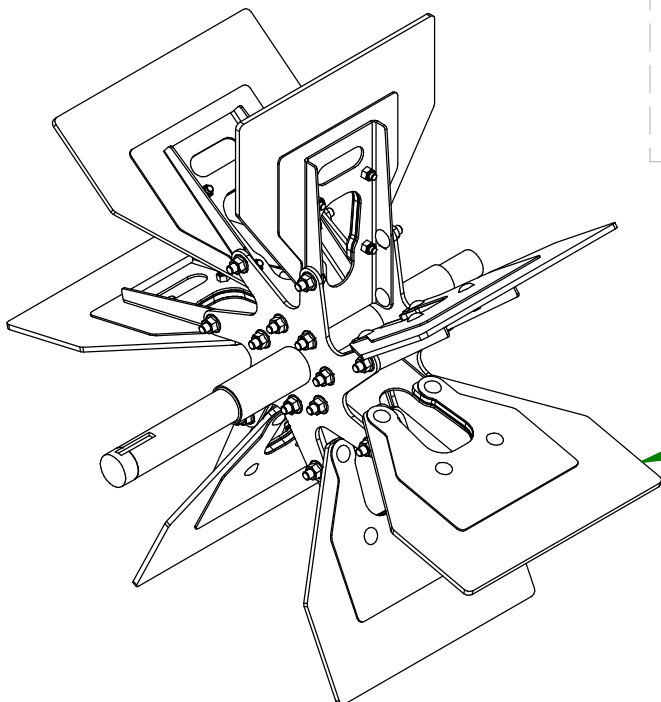

32-57-6000  
IMPELLER

USE THESE PIECES ONLY IF YOUR SERIAL  
NUMBER IS AFFECTED:

BETWEEN #39751 AND #45452

**AGRIMETAL**  
**IMPELLER**

CREATION : 06/10/20  
REVISION : 19/03/24

ASSEMBLY : **32-57-6000**  
AUTHOR : J. Houle

#	PART #	QTY	TITLE
1	12-38-0030	1	FLANGE BEARING 4 HOLES UCF 208-24 X 1 1/2"
2	NC01-17-0396	4	HEX. BOLT GR2 ZINC 5/8-11 X 2"
3	NC02-32-0016	4	LOCK WASHER ZINC 5/8"
4	NC02-07-0022	4	HEX. NUT ZINC 5/8-11
5	12-38-0001	1	FLANGE BEARING UCF 207-20
6	12-01-3051	1	REAR BEARING PROTECTOR
7	NC01-17-0250	4	HEX. BOLT GR2 ZINC 1/2-13 X 1 3/4"
8	NC02-25-0011	4	WASHER SAE ZINC 17/32 ID
9	NC02-32-0014	4	LOCK WASHER ZINC 1/2"
10	NC02-07-0020	4	HEX. NUT ZINC 1/2-13
11	NC14-62-0198	1	PULLEY QD 3V 1/2-5/8 X 4.95 OD X SD (3B46)
12	NC14-62-0007	1	QD BUSHING SD 1 1/2"
13	12-41-0915	1	PULLEY KEY
14	32-57-6001	1	IMPELLER

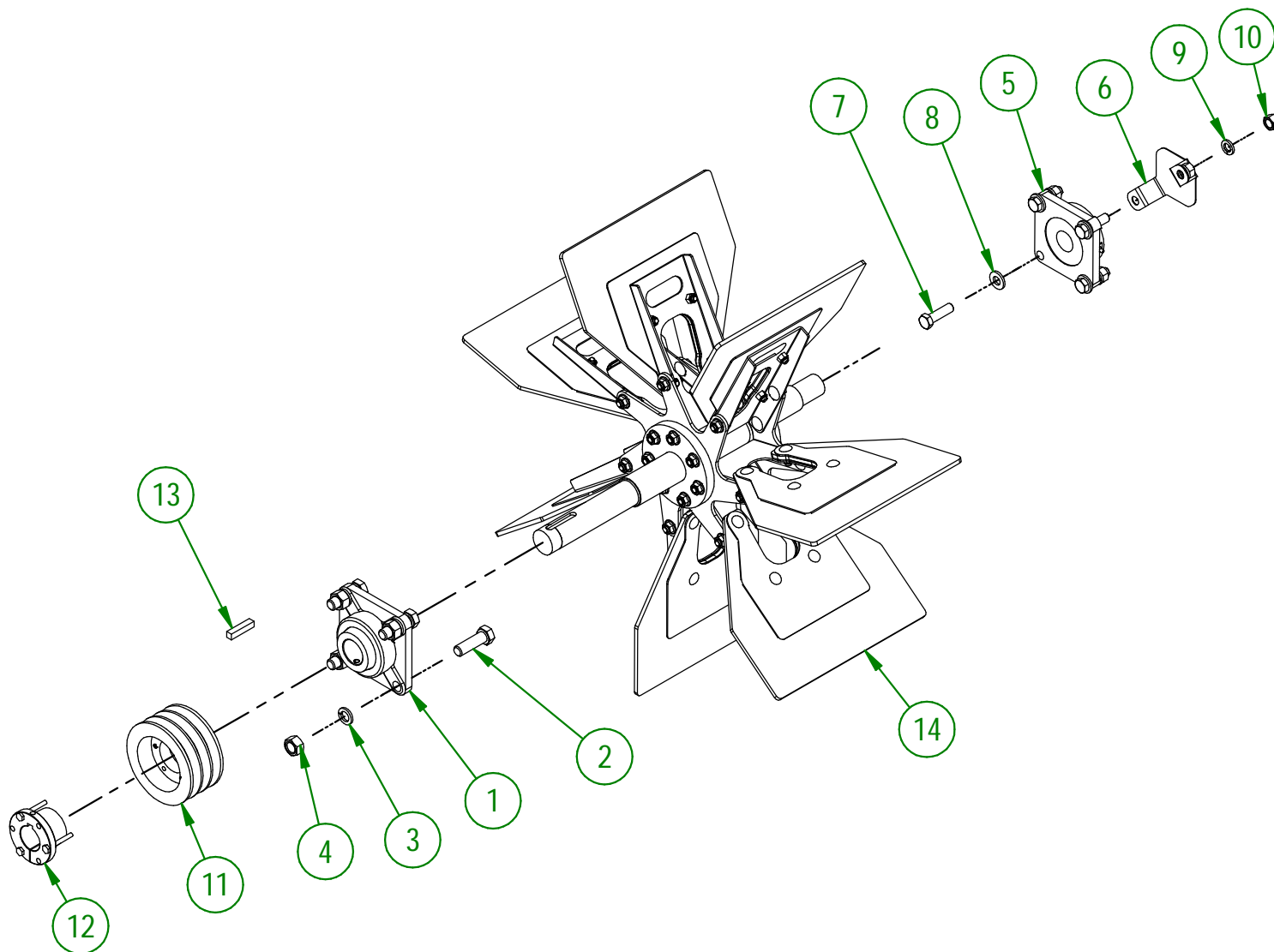

UTILISER CES PIÈCES SEULEMENT SI VOTRE NUMÉRO DE SÉRIE EST CONCERNÉ:

#45453 ET PLUS

**AGRIMETAL**  
ASSEMBLY IMPELLER

CREATION : 26/03/24  
REVISION : 05/01/26

ASSEMBLY : **32-57-6006**  
AUTHOR : J. Houle

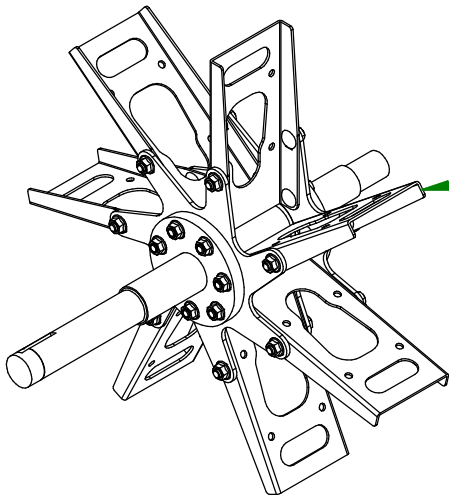

32-50-6001  
IMPELLER FRAME

32-57-6011  
IMPELLER PADDLE AND  
PADDLE REINFORCEMENT GROUP

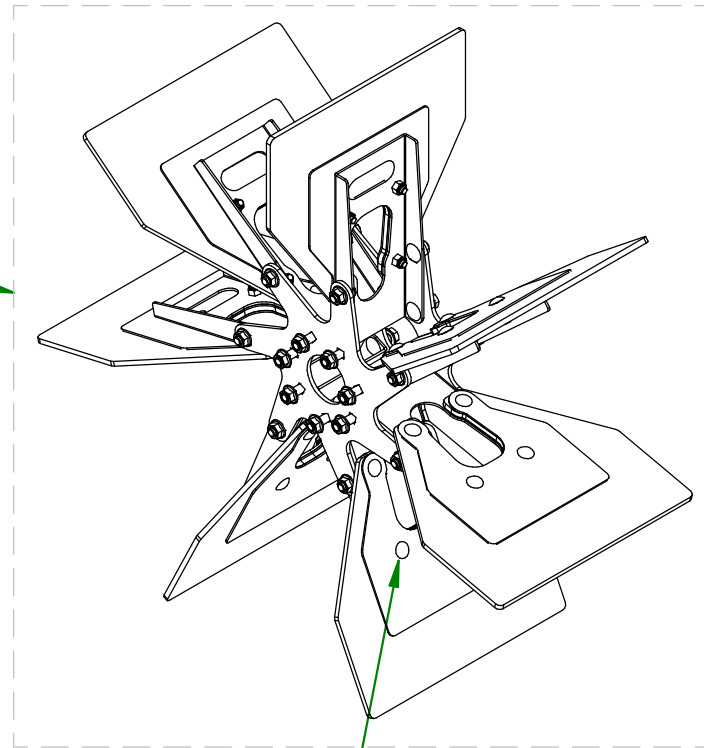

TORQUE AT  
120 INCH POUNDS

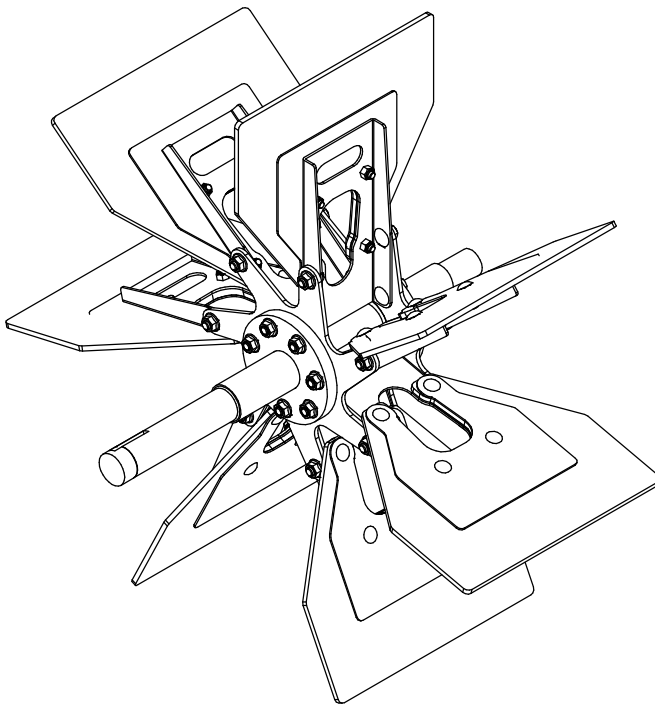

32-57-6001  
IMPELLER

USE THESE PIECES ONLY IF YOUR SERIAL  
NUMBER IS AFFECTED:

#45453 AND ABOVE

**AGRIMETAL**  
**IMPELLER**

CREATION : 19/03/24  
REVISION : 19/03/24

ASSEMBLY : **32-57-6001**  
AUTHOR : J. Houle

32-57-3051

#	PART #	Qty	TITLE
1	32-57-3006	1	CASING COVER
2	NC01-04-0107	8	CARR. BOLT GR2 ZINC 3/8-16 X 3/4"
3	NC02-14-0019	10	FLANGE NUT HEX. NC 3/8-16 GR. B

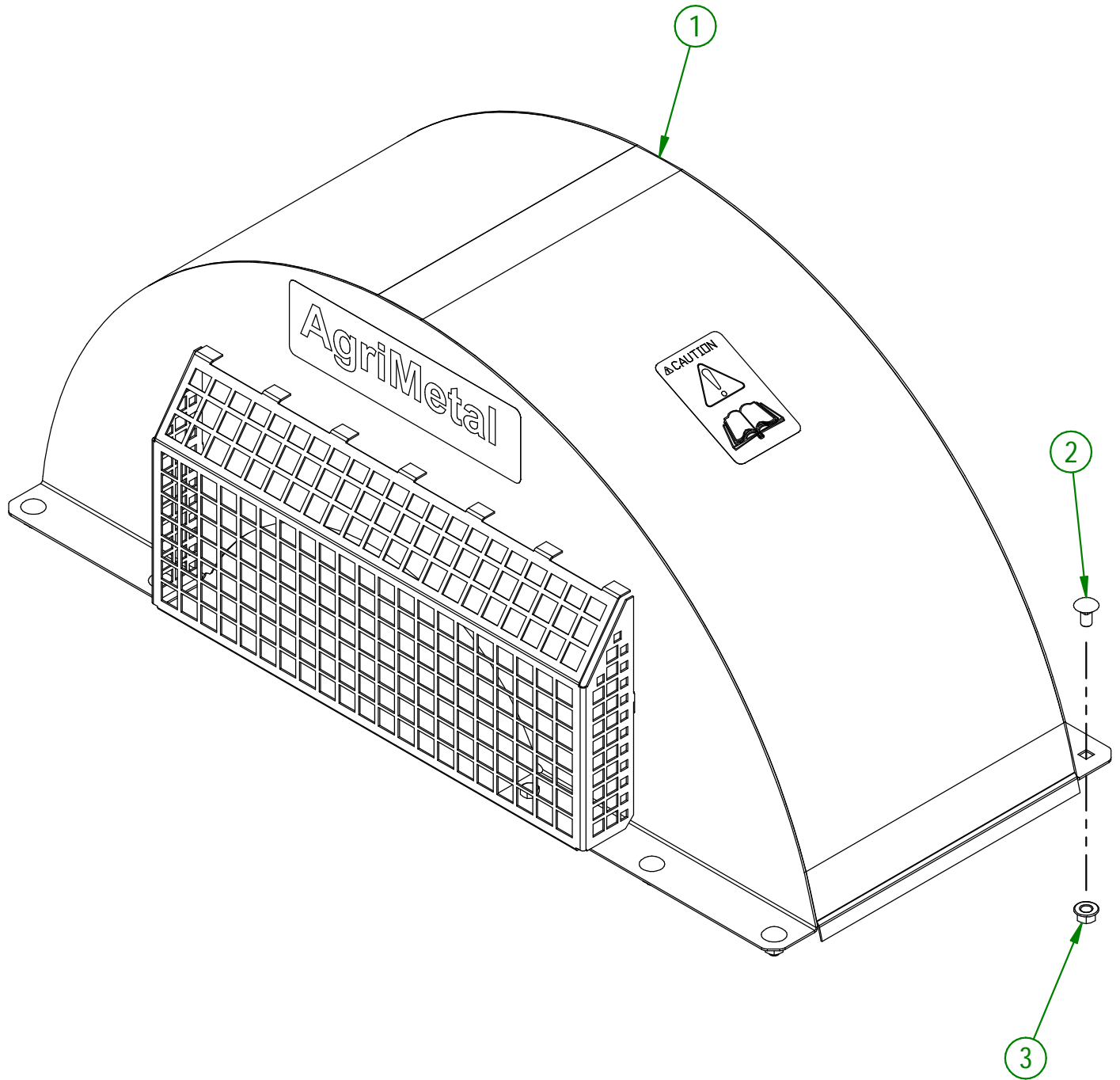

<b>AGRIMETAL</b>	
<b>ASSEMBLY CASING COVER</b>	
CREATION : 16/06/22	ASSEMBLY : <b>32-57-3051</b>
REVISION : 16/06/22	AUTHOR : J. Houle

32-57-1105

#	PART #	Qty	TITLE
1	NCI3-30-0237	1	PLASTIC TUBE FOR OPERATOR'S MANUAL
2	NC01-04-0003	3	CARR. BOLT GR2 ZINC 1/4-20 X 3/4"
3	NC02-25-0007	3	WASHER ZINC 0.281 = 9/32
4	NC01-96-0009	3	NYLON-INSERT LOCKNUT ZINC 1/4-20
5	32-98-0626	1	OPERATOR MANUAL BW 2500-3500-4500

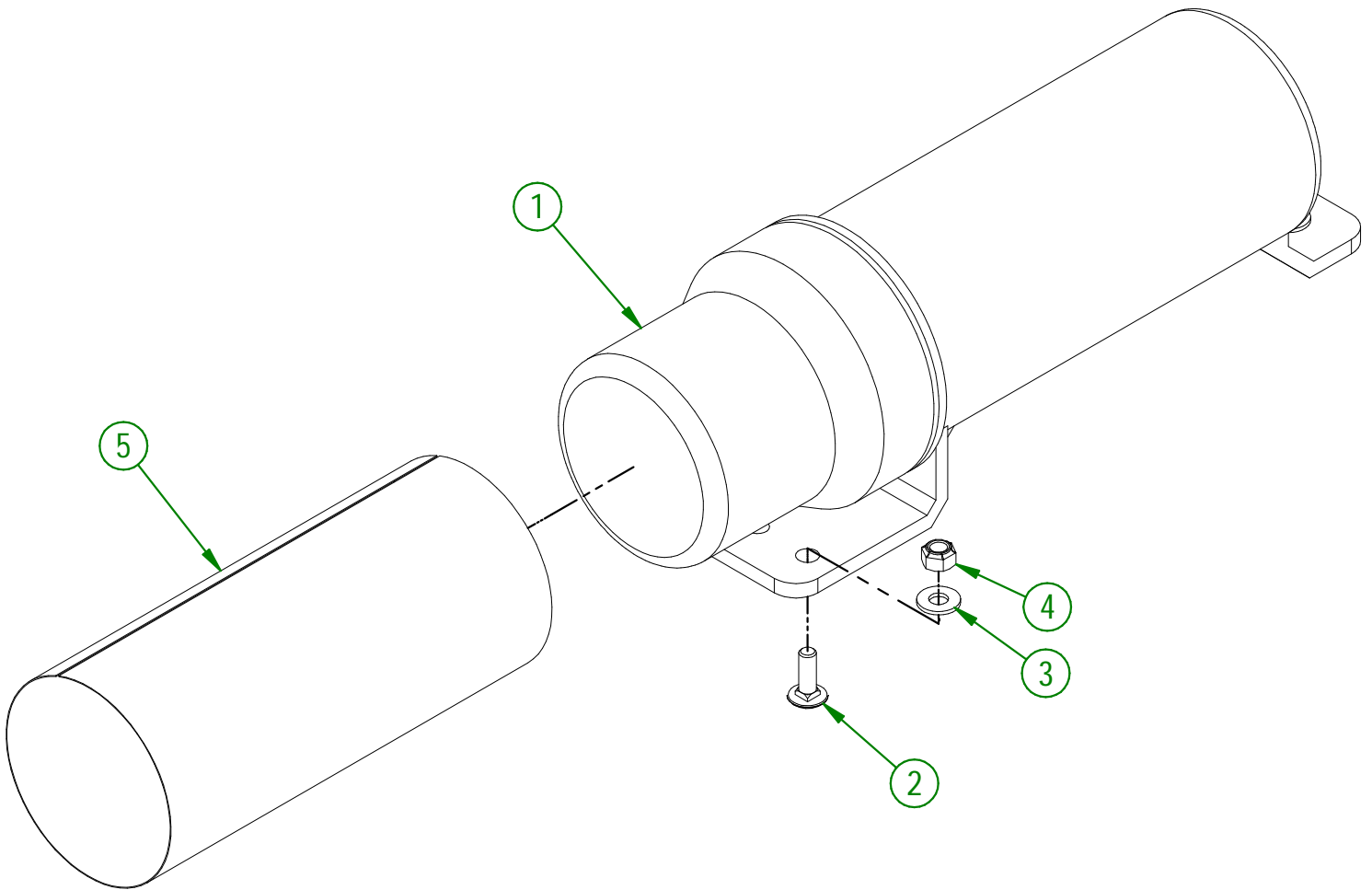

<b>AGRIMETAL</b>	
<b>OPERATOR MANUEL</b>	
CREATION : 13/03/17	ASSEMBLY : <b>32-57-1105</b>
REVISION : 16/06/22	AUTHOR : F.HÉLIE

#	PART #	QTY	TITLE
1	NCI3-33-0353	2	STICKER B-25
2	NCI3-33-0290	1	STICKER DANGER
3	NCI3-33-0163	1	STICKER LOW DECIBEL
4	NCI3-33-0024	6	STICKER GREASE HERE
5	NCI3-33-0186	1	STICKER (DANGER)
6	NCI3-33-0192	3	STICKER (PROJECTION RISK)
7	NCI3-33-2686	1	STICKER IMPORTANT
8	NCI3-33-0035	2	STICKER AGRIMETAL
9	NCI3-33-0183	1	STICKER CAUTION OPERATION MANUAL
10	NCI3-33-0305	1	STICKER 75 dB
11	NCI3-33-0187	1	STICKER DANGER (PTO AND PERSON)
12	NCI3-33-0287	1	STICKER WARNING
13	NCI3-33-0298	2	STICKER PULL THIS WAY TO OPEN
14	NCI3-33-0005	1	STICKER MAXIMUM 540 RPM
15	NCI3-33-0179	1	STICKER IMPORTANT GREASE DRIVE LINE

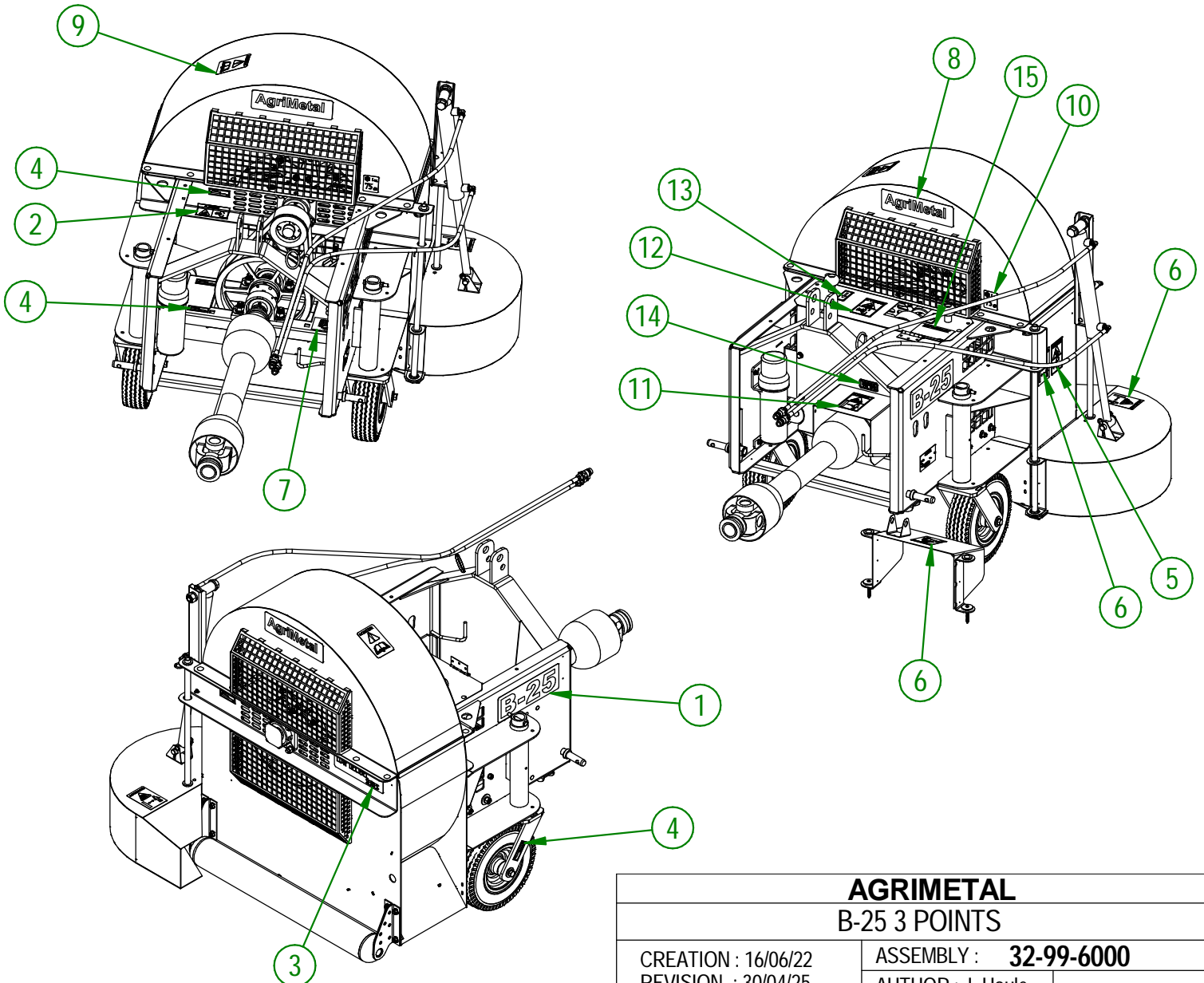

**AGRIMETAL**  
B-25 3 POINTS

CREATION : 16/06/22  
REVISION : 30/04/25

ASSEMBLY : **32-99-6000**  
AUTHOR : J. Houle