

AgriMetal

PARTS LIST

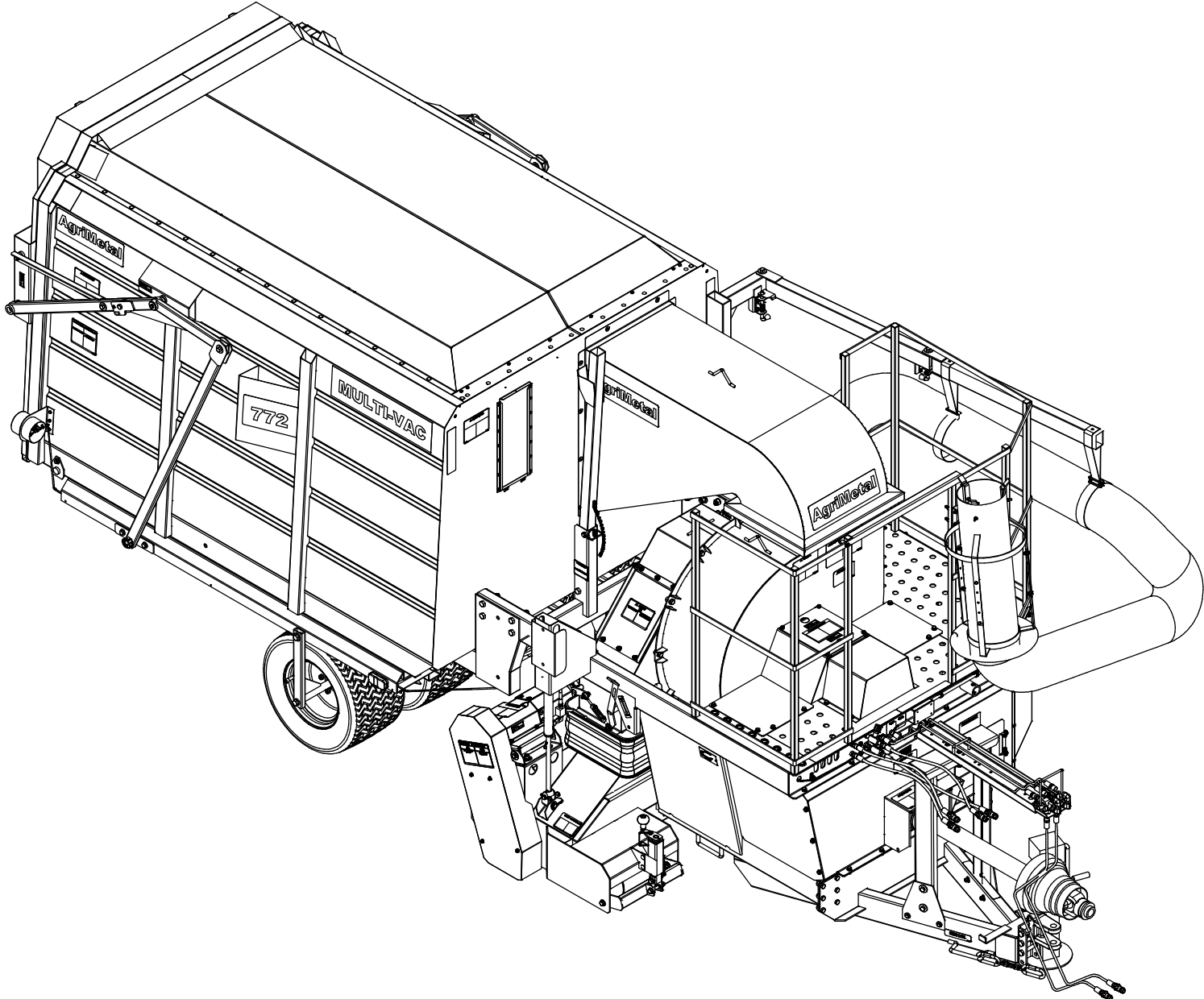

MULTI-VAC 772

#	PART #	Qty	TITLE
1	25-55-0710	1	SERIAL NUMBER PLATE
2	28-50-0016	1	JACK
3	16-41-0040	1	CHAIN 58"
4	NC01-75-0007	2	CONNECTING LINK APROUVED 1/2 3300/LBS WLL
5	NC13-80-0241	1	ADJUSTABLE 1" CLEVIS (3 HOLES)
6	NC02-32-0016	3	LOCK WASHER ZINC 5/8"
7	NC01-33-0406	3	HEX. BOLT GR8 ZINC 5/8-11 X 4 1/2" LG
8	NC02-07-0022	3	HEX. NUT ZINC 5/8-11
9	28-34-0030	1	PTO SHAFT T60 X 45.98"
10	29-34-0030	1	PTO SHAFT T20 X 48.35"
11	29-34-0035	1	PTO SHAFT T20 X 35.35"

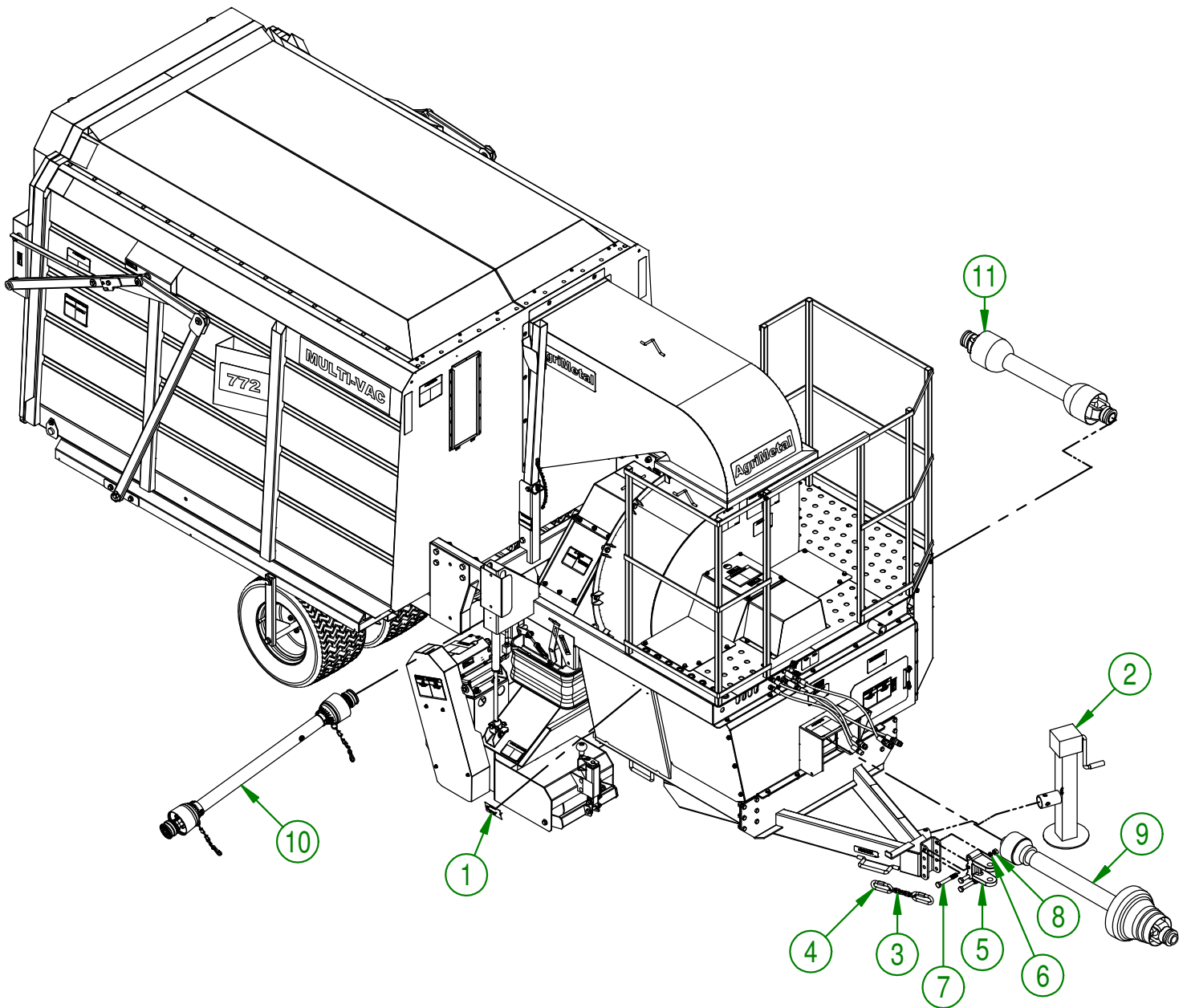

AGRIMETAL	
MULTI-VAC 772 PTO (RUBBER FINGER)	
CREATION : 31/07/17	ASSEMBLY : 29-99-0000
REVISION : 07/05/18	AUTHOR : J.KABWE Page 1 de 72

#AGRIMETAL : 28-34-0030

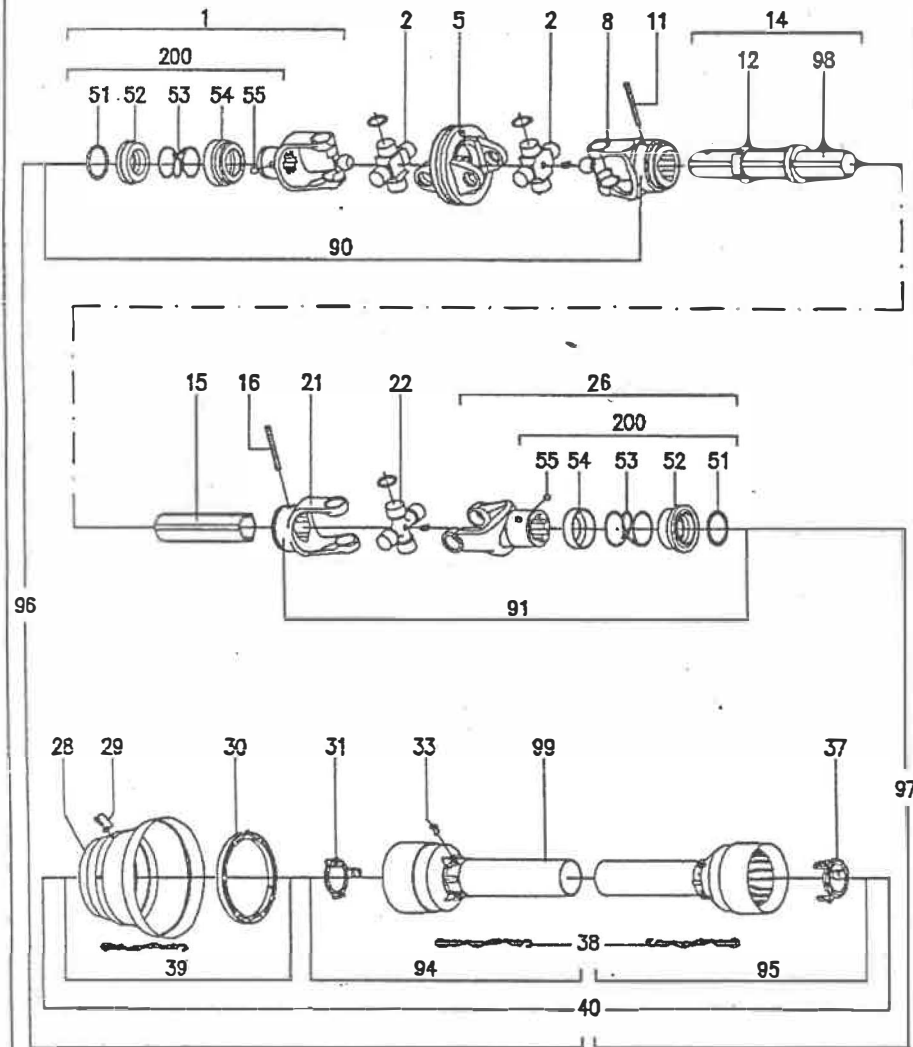

Pos.	Description	Q.ty	Code	Pos.
1	Complete collar yoke-C02- for CV-joint 1 3/8" Z6	1	141.026.503	1.
2	Cross journal set for CV-joint $\varnothing 30.2 \times 101.4$	2	180.016.228	2
5	Wide angle double yoke	1	141.026.224	5
8	Outer yoke for CV-joint	1	141.026.229	8
11	Roll pin for outer tube	1	190.000.018	11
12	Bush with grease fitting	1	180.016.316	12
14	Complete outer tube L=0650	1	152.160.579.7820	14
15	Inner tube L=0665	1	159.160.840	15
16	Roll pin for inner tube	1	190.000.016	16
21	Inner yoke	1	151.016.029	21
22	Cross journal set $\varnothing 30.2 \times 92$	1	180.016.004	22
26	Complete collar yoke C12 1 3/8" Z6	1	141.026.544	26
28	Guard cone for wide angle CV-joint	1	180.016.244	28
29	Screw	6	190.000.296	29
30	Bearing ring	1	180.016.245	30
31	Guard retaining collar for outer tube	1	180.016.016	31
33	Bolt	6	190.000.019	33
37	Guard retaining collar for inner tube	1	180.016.015	37
38	Safety chains	3	180.016.025	38
39	Guard cone set	1	165.000.570	39
40	Complete guard with Instruction Manual	1	142.761.039.3620	40
51	Outer circlip	2	190.000.451	51
52	Sliding sleeve collar	2	151.016.486	52
53	Spring	2	180.016.487	53
54	Fixed sleeve collar	2	180.016.483	54
55	Ball $\varnothing 1/2"$	6	190.000.078	55
90	Wide angle CV-joint for outer tube	1	121.026.658.00	90
91	U Joint for inner tube	1	121.026.900.00	91
94	Hoff female guard	1	142.261.032.3620	94
95	Half male guard	1	142.261.329.3620	95
96	Half female shaft with guarding	1	179610810FD2502	96
97	Half male shaft with guarding	1	123.460.996.00	97
98	"DANGER" Label for outer tube	1	190.000.216	98
99	"DANGER" Label for outer guard tube	1	190.000.215	99
100	Instruction manual	1	190.000.371	100
200	Kit collar 1 3/8"	2	165.000.628	200

Date:

Code:

Customer code:

Description:

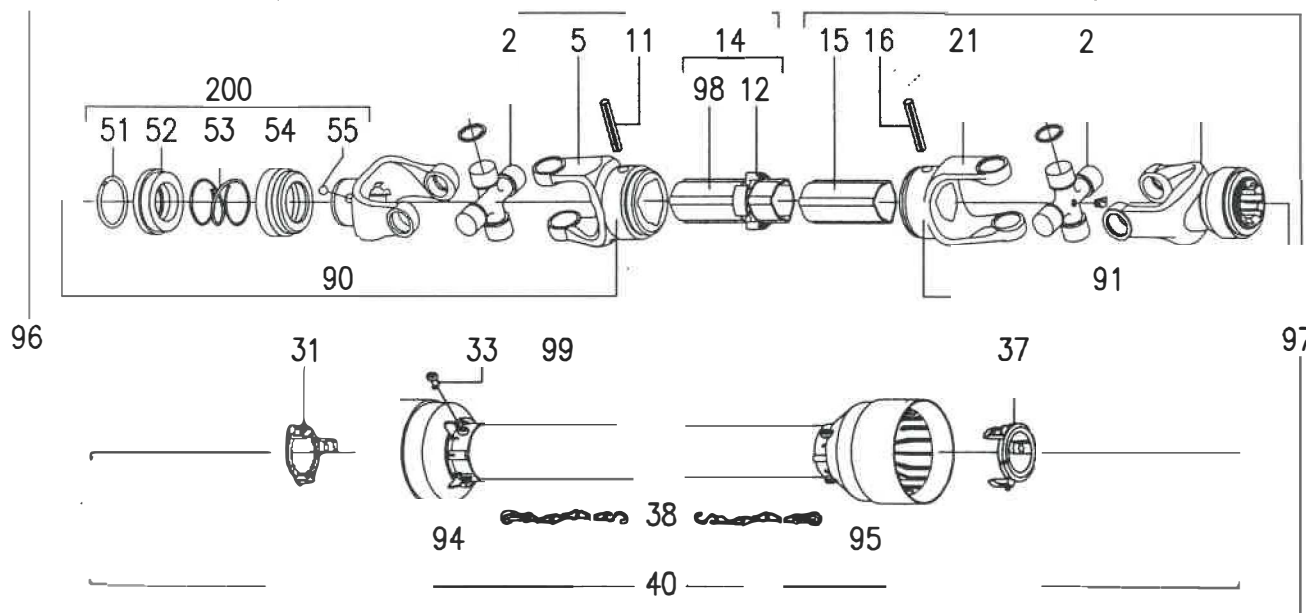

Pos.	Description	Q.t	Code	Pos.
1	Complete collar yoke C12	1 3/8" Z6	141.022.324	1
2	Cross journal set	23.8x61.3	180.012.130	2
5	Outer yoke		151.012.003	5
11	Roll pin for outer tube		190.000.012	11
12	Bush with grease fitting		180.012.180	12
14	Complete outer tube	L=0885	152.120.384.0720	14
15	Inner tube	L=0900	153.120.112	15
16	Roll pin for inner tube		190.000.011	16
21	Inner yoke		151.012.002	21
30				30
31	Guard retaining collar for outer tube		180.012.007	31
33	Bolt	6	190.000.019	33
37	Guard retaining collar for inner tube		180.012.006	37
38	Safety chains	2	180.016.025	38
40	Complete guard with instruction manual	1	142.220.333.7220	40
51	Outer circlip	2	190.000.451	51
52	Sliding sleeve collar	2	151.016.486	52
53	Spring	2	180.016.487	53
54	Fixed sleeve	2	180.016.483	54
55	Ball ø1\2"	6	190.000.078	55
90	U Joint for outer tube	1	121.022.644.10	90
91	U Joint for inner tube	1	121.022.645.10	91
94	Half female guarding	1	142.226.074.7220	94
95	Half male guarding	1	142.221.249.7220	95
96	Half female shaft with guarding	1	123.320.160.10	96
97	Half male shaft with guarding	1	123.420.364.10	97
98	"DANGER" Label for outer tube	1	190.000.216	98
99	"DANGER" Label for outer guard tube	1	190.000.215	99
100	Instruction manual	1	190.000.371	100
200	Kit collar 1 3/8"	2	165.000.628	200

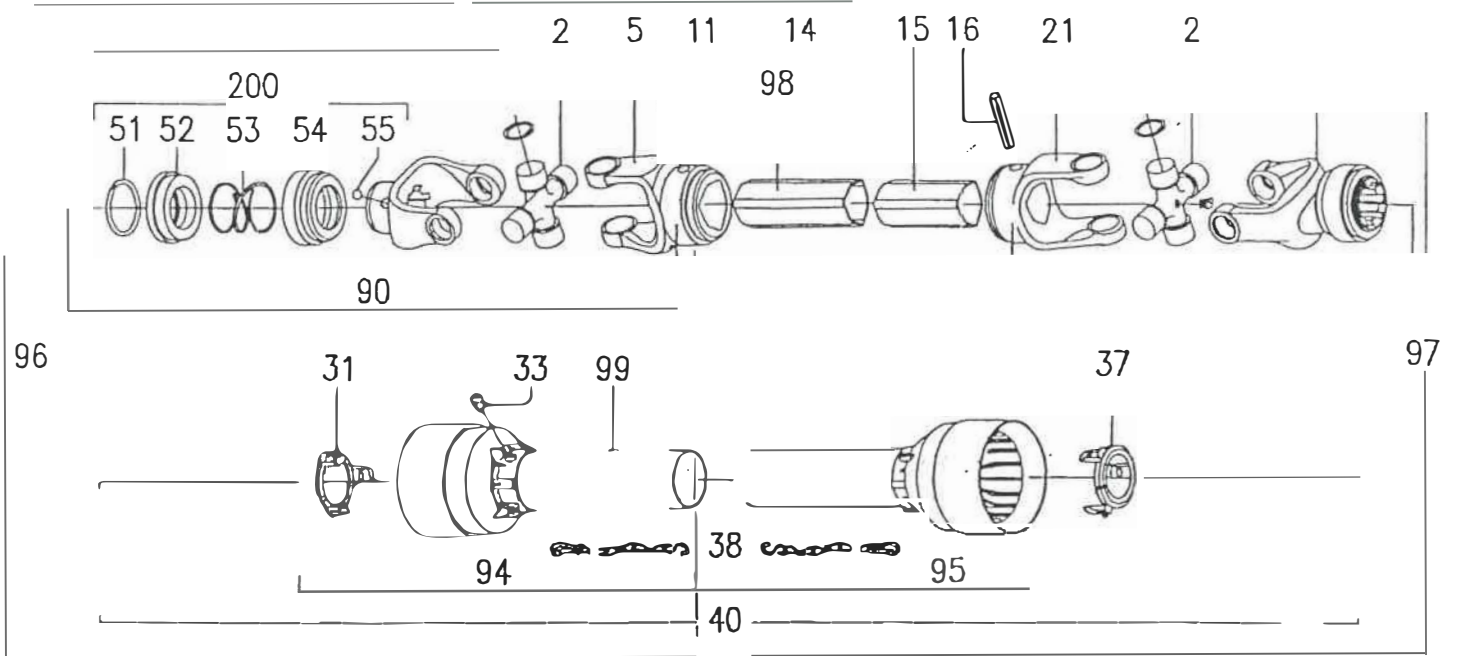

Pos.	Description		Q.ty	Code	Pos.
1	Complete collar yoke C12	1 3/8" Z6	2	141.022.324	1
2	Cross journal set	23.8x61.3	2	180.012.130	2
5	Outer yoke		1	151.012.003	5
11	Roll pin for outer tube		1	190.000.012	11
14	Complete outer tube	∅=0555	1	152.120.352.0720	14
15	Inner tube	∅=0570	1	153.120.132	15
16	Roll pin for inner tube		1	190.000.011	16
21	Inner yoke		1	151.012.002	21
30					30
31	Guard retaining collar for outer tube		1	180.012.007	31
33	Bolt		6	190.000.019	33
37	Guard retaining collar for inner tube		1	180.012.006	37
38	Safety chains		2	180.016.025	38
40	Complete guard with instruction manual		1	142.220.268.7220	40
51	Outer circlip		2	190.000.451	51
52	Sliding sleeve collar		2	151.016.486	52
53	Spring		2	180.016.487	53
54	Fixed sleeve		2	180.016.483	54
55	Ball ∅1 1/2"		6	190.000.078	55
90	U Joint for outer tube		1	121.022.644.10	90
91	U Joint for inner tube		1	121.022.645.10	91
94	Half female guarding		1	142.221.164.7220	94
95	Half male guarding		1	142.221.252.7220	95
96	Half female shaft with guarding		1	123.320.104.10	96
97	Half male shaft with guarding		1	123.420.237.10	97
98	"DANGER" Label for outer tube		1	190.000.216	98
99	"DANGER" Label for outer guard tube		1	190.000.215	99
100	Instruction manual		1	190.000.371	100
200	Kit collar 1 3/8"		2	165.000.628	200

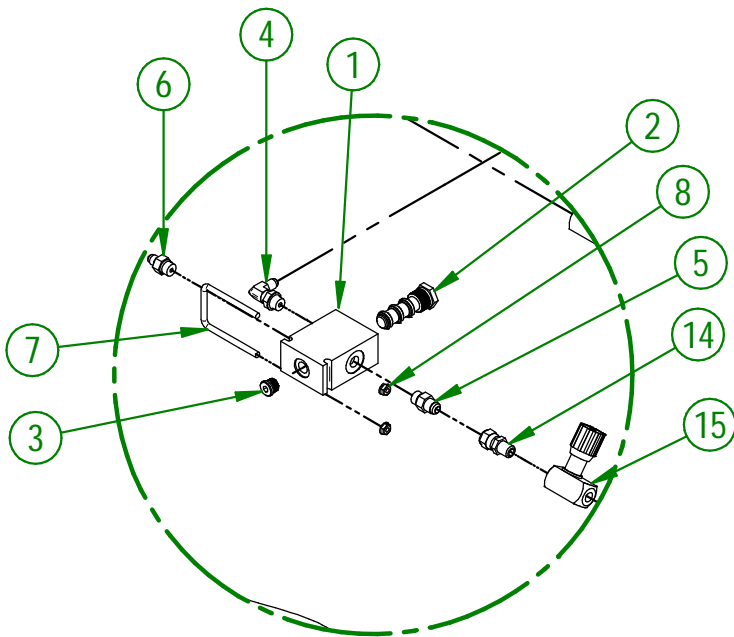
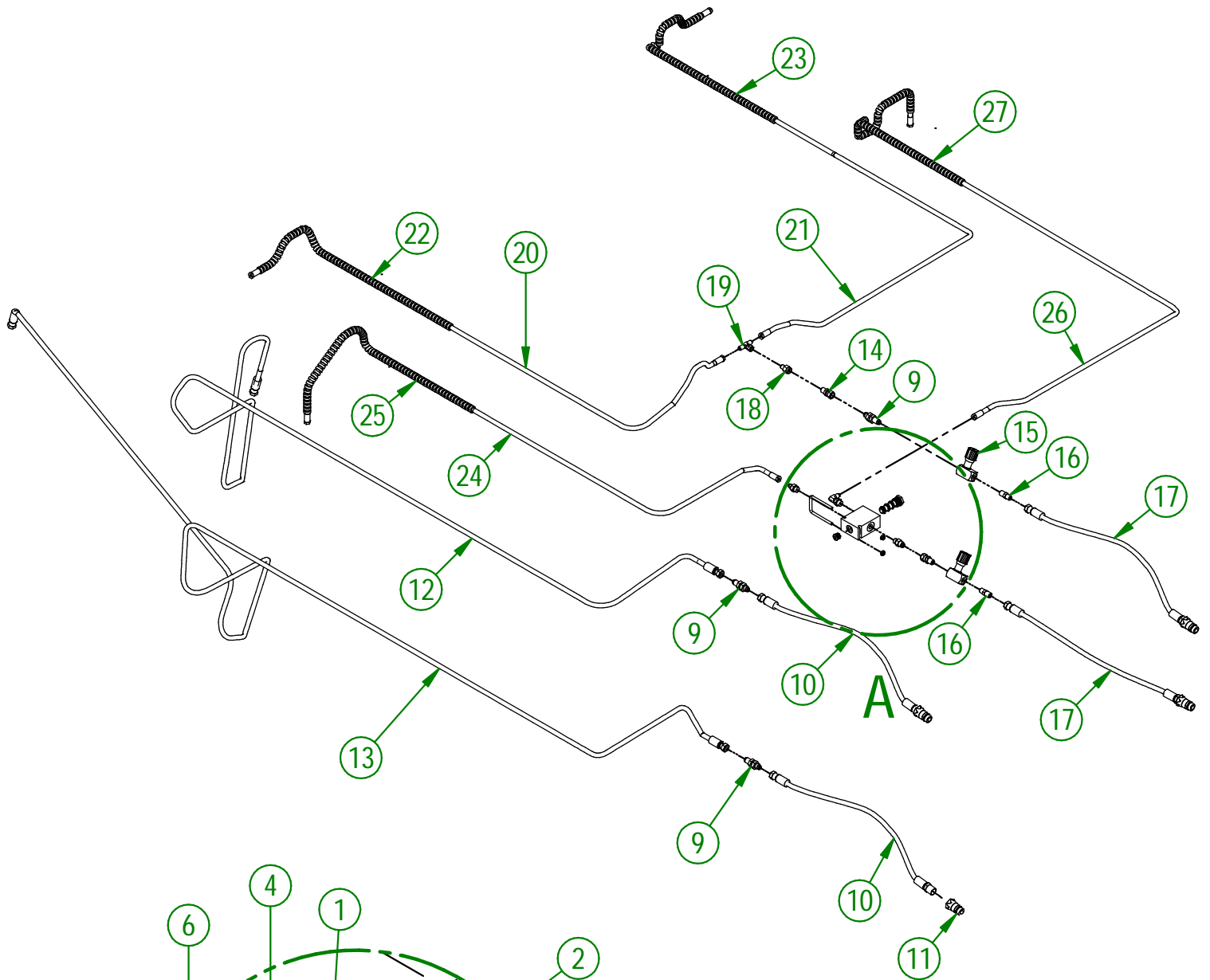

DETAIL A

AGRIMETAL	
DIVIDER/COMBINER BLOCK WITH HYDR. HOSE	
CREATION : 24/11/17	ASSEMBLY : 29-57-0105
REVISION : 16/01/26	AUTHOR : J.KABWE

#	PART #	Qty	TITLE
1	NCI3-45-0150	1	HYDRAULIC BLOC SAE 6
2	NCI3-45-0151	1	FLOW DIVIDER/COMBINER CARTRIDGE VALVE
3	NCI3-45-0145	1	MALE CAP WITH O'RING BOSS (SAE6)
4	NCI3-45-0160	1	90° MALE SAE O' RING X 1/4" X MALE JIC
5	NCI3-45-0165	1	UNION 3/8 MALE JIC X 3/8 MALE WITH O'RING BOSS
6	NCI3-45-0154	1	UNION 1/4 MALE JIC X 3/8 MALE O'RING BOSS
7	29-20-0005	1	HYDRAULIC BLOCK U BOLT
8	NC02-14-0017	2	FLANGED NUT GR. B 1/4-20
9	NCI3-45-0144	3	FLEXIBLE UNION 3/8 MALE JIC X 3/8 MALE JIC WITH NUT
10	NCI7-02-0334	2	HYDRAULIC HOSE 3/8 X 72" CUT 1/2 NPT MALE RIG. X 3/8 JIC FEM.
11	NCI3-45-0014	2	QUICK COUPLER 1/2-14 NPTF
12	NCI7-02-0341	1	HYDRAULIC HOSE 3/8 X 118"CUT 3/8 JIC 37 FEM.X 3/8 JIC 37 FEM.
13	NCI7-02-0342	1	HYDRAULIC HOSE 3/8 X 157"CUT 3/8 JIC 37 FEM.X 3/8 JIC 37 FEM.
14	NCI3-45-0164	2	UNION 1/4 MALE NPT X 3/8 FEM. TOUR. JIC
15	NCI3-45-0162	2	FLOW CONTROL 1/4 MALE NPT
16	NCI3-45-0163	2	UNION 1/4 MALE NPT X 3/8 MALE JIC
17	28-55-0335	2	HYDRAULIC HOSE QUICK COUPLER MALE X 1/2-14 NPT FEMALE X 72"
18	NCI3-45-0157	1	REDUCING 3/8 FEM JIC X 1/4 MÂLE JIC
19	NCI3-45-0156	1	T 1/4 MALE JIC X 1/4 FEM. SWIVEL JIC
20	NCI7-02-0337	1	HYDRAULIC HOSE 1/4 X 71" CUT 1/4 JIC 37 FEM. X 1/4 JIC 37 FEM.
21	NCI7-02-0339	1	HYDRAULIC HOSE 1/4 X 86" CUT 1/4 JIC 37 FEM. X 1/4 JIC 37 FEM.
22	29-42-0010	1	HOSE PROTECTOR
23	29-42-0010	1	HOSE PROTECTOR
24	NCI7-02-0338	1	HYDRAULIC HOSE 1/4 X 82"CUT 1/4 JIC 37 FEMALE X 1/4 JIC 37 FEMAL
25	29-42-0010	1	HOSE PROTECTOR
26	NCI7-02-0340	1	HYDRAULIC HOSE 1/4 X 100"CUT 1/4 JIC 37 FEM. X 1/4 JIC 37 FEM.
27	29-42-0010	1	HOSE PROTECTOR

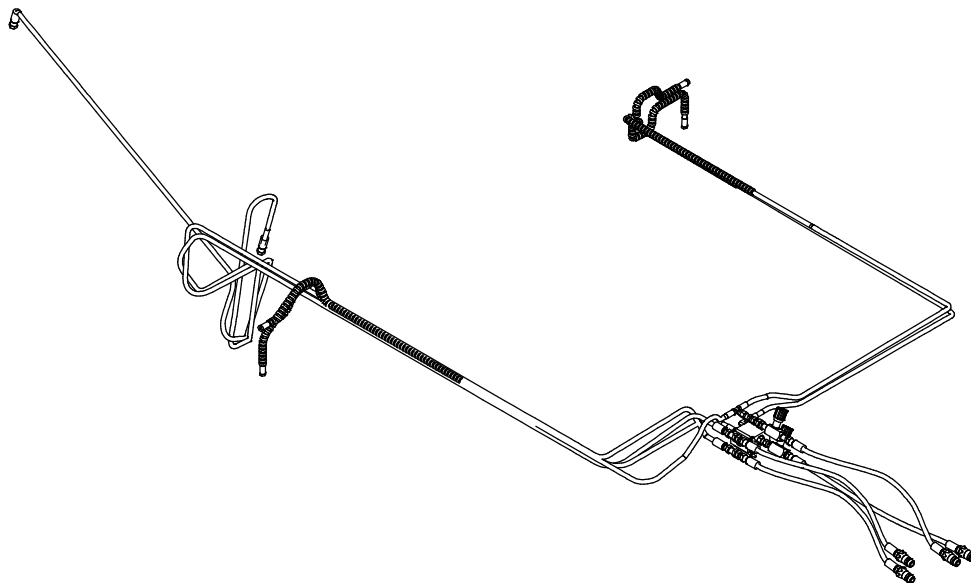

AGRIMETAL

DIVIDER/COMBINER BLOCK WITH HYDR. HOSE

CREATION : 24/11/17
REVISION : 16/01/26

ASSEMBLY : **29-57-0105**
AUTHOR : J.KABWE

29-57-0001

#	PART #	Qty	TITLE
1	29-57-0002	1	FRONT FRAME "STIKER INCLUDED"
2	29-57-0000	1	BACK FRAME " STICKER INCLUDED"
3	NC01-17-0402	8	HEX. BOLT GR2 ZINC 5/8-11 X 3 1/2"
4	NC02-32-0016	8	LOCK WASHER ZINC 5/8"
5	NC02-07-0022	8	HEX. NUT ZINC 5/8-11

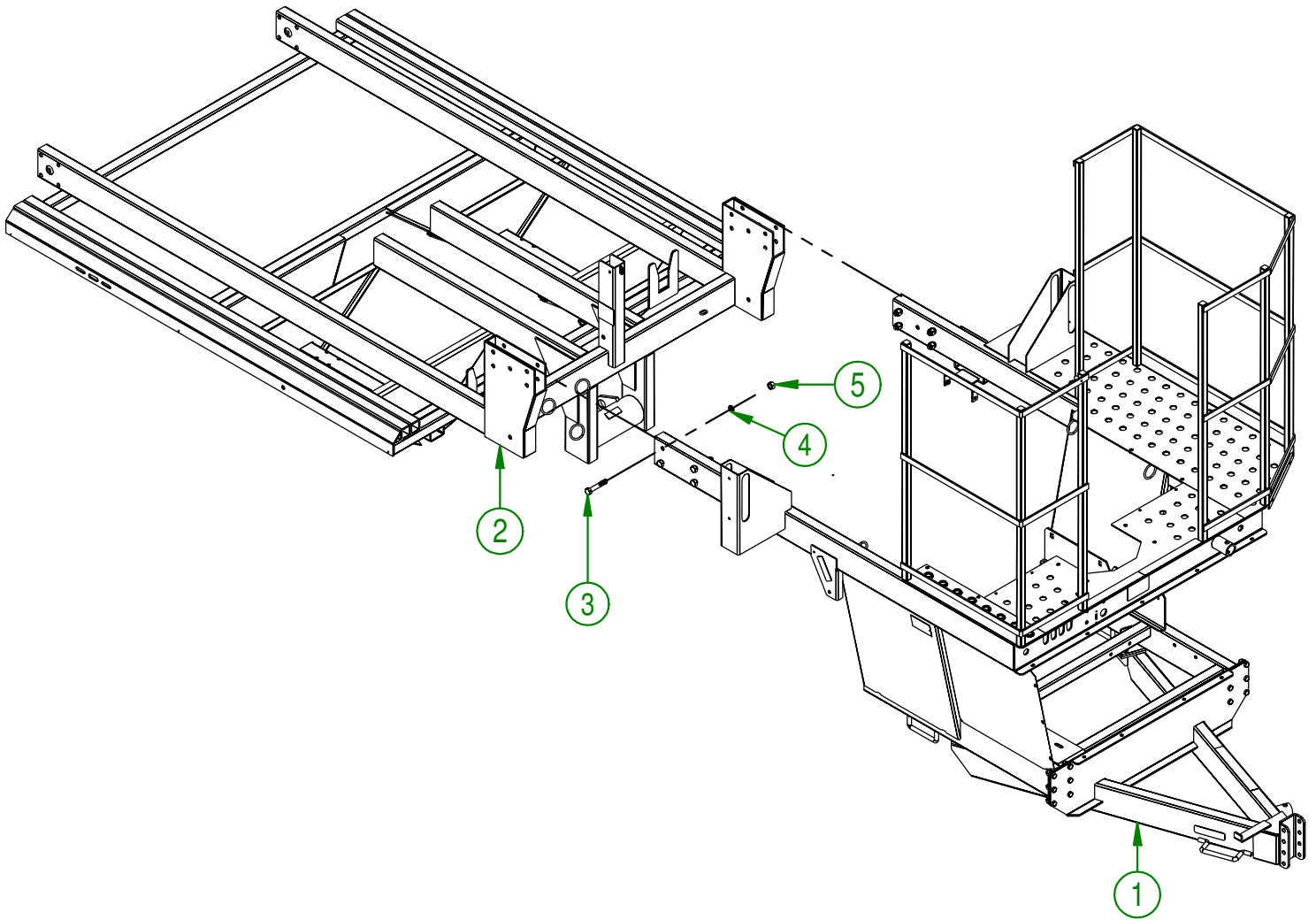

AGRIMETAL
FRONT & BACK FRAME

CREATION : 31/07/17
REVISION : 25/01/18

ASSEMBLY : **29-57-0001**

AUTHOR : J.KABWE Page 7 de 72

#	PART #	Qty	TITLE
1	28-01-1700	1	RAMP SAFETY GATE
2	NC01-17-0065	1	HEX. BOLT GR2. ZINC 5/16-18 X 2 1/4"
3	NC02-22-0008	2	WASHER ZINC 5/16"
4	NC01-96-0010	1	NYLON NUT HEX. ZINC 5/16-18

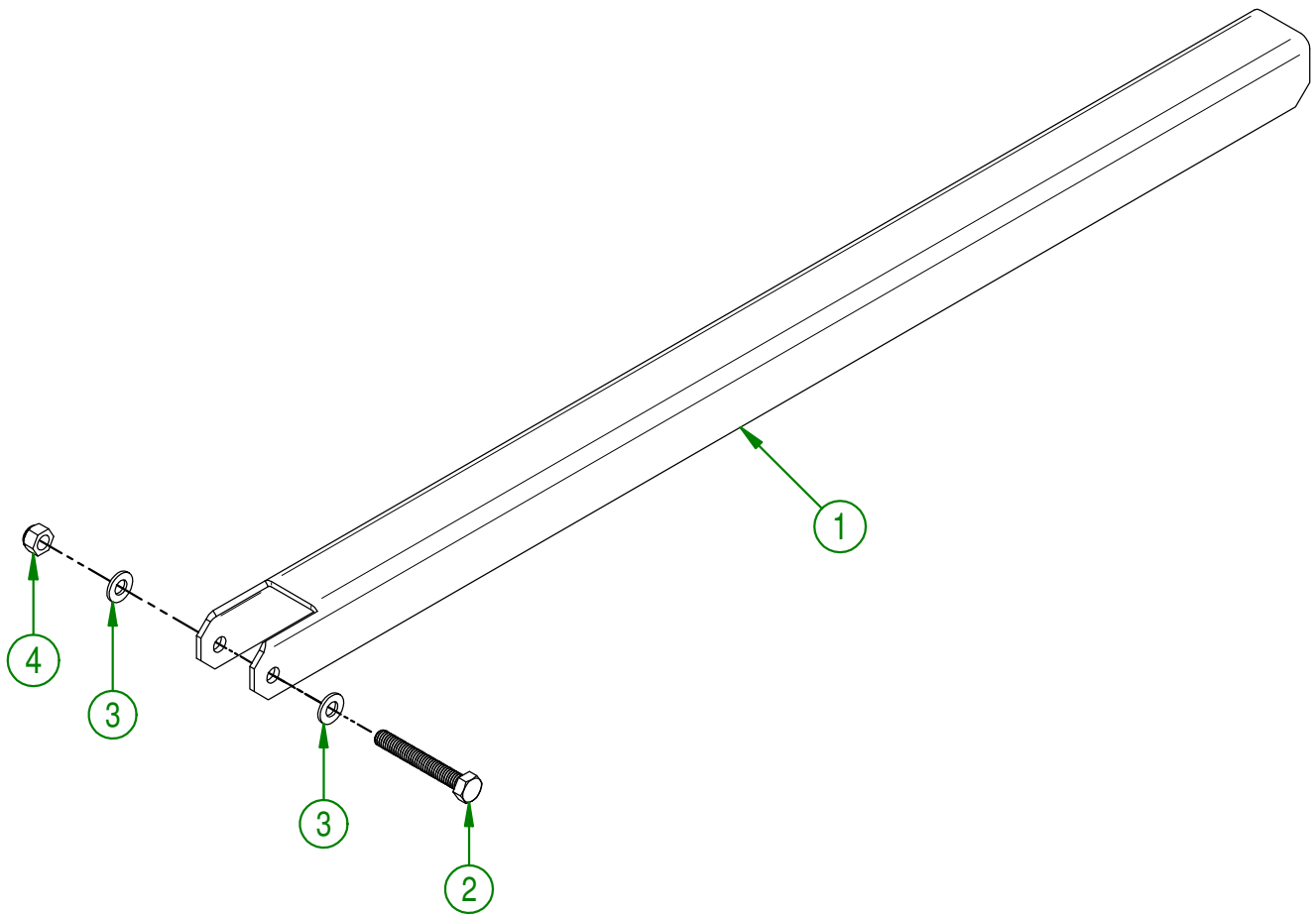

AGRIMETAL	
RAMP SECURITY DOOR ASSEMBLY	
CREATION : 03/07/17	ASSEMBLY : 28-57-0315
REVISION : 25/01/18	AUTHOR : J.KABWE Page 8 de 72

#	PART #	Qty	TITLE
1	16-01-0000	2	AXLE PLAT WASHER
2	16-50-0100	2	WHEEL HUB CAGE
3	28-01-0930	2	TANDEM END PLAT WASHER
4	28-42-0100	2	AXLE BUSHING (UHMW)
5	28-50-0140	1	AXLE
6	NC01-17-0248	2	HEX. BOLT GR2 ZINC 1/2-13 X 1 1/4"
7	NC01-17-0271	8	HEX BOLT GR2 NC ZINC 1/2-13 X 7"
8	NC01-29-0248	10	HEX. BOLT GR5 NF ZINC 1/2-20 X 1 1/4
9	NC01-69-0798	2	GREASE FITTING 1/4" NPT X RIGHT
10	NC01-98-0021	2	HEX. BLOC NUT 1 1/4-18
11	NC02-07-0020	8	HEX. NUT ZINC 1/2-13
12	NC02-25-0011	8	WASHER SAE ZINC 17/32 ID
13	NC02-32-0014	18	LOCK WASHER ZINC 1/2"
14	NC14-70-0302	2	24" DIA. WUEEL ASSY.
15	NC14-75-0071	4	BALL BEARING 6207-2RS KML ONLY

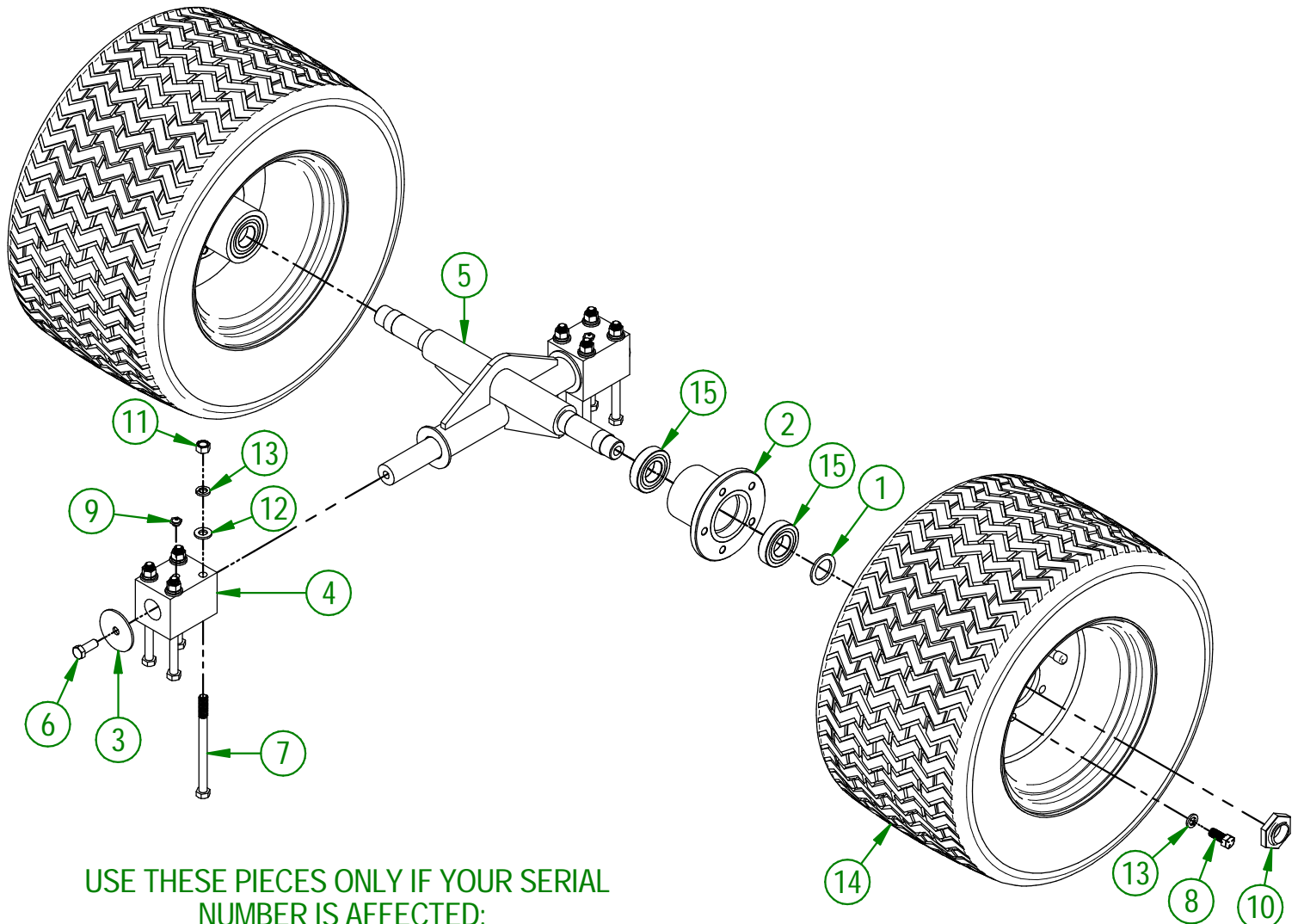

USE THESE PIECES ONLY IF YOUR SERIAL NUMBER IS AFFECTED:

#43816 AND MORE

AGRIMETAL
AXLE ASSY.

CREATION : 30/05/24
REVISION : 30/05/24

ASSEMBLY : **28-57-0095**
AUTHOR : M. HOULE

#	PART #	Qty	TITLE
1	28-50-0140	1	AXLE
2	16-50-0100	2	WHEEL HUB CAGE
3	NC14-75-0071	4	BALL BEARING 6207-2RS KML ONLY
4	NC01-29-0248	10	HEX. BOLT GR5 NF ZINC 1/2-20 X 1 1/4
5	NC14-70-0302	2	24" DIA. WUEEL ASSY.
6	NC02-32-0014	18	LOCK WASHER ZINC 1/2"
7	28-42-0101	2	AXLE BUSHING (UHMW)
8	NC01-69-0798	2	GREASE FITTING 1/4" NPT X RIGHT
9	28-01-0930	2	TANDEM END PLAT WASHER
10	NC01-17-0248	2	HEX. BOLT GR2 ZINC 1/2-13 X 1 1/4"
11	16-01-0000	2	AXLE PLAT WASHER
12	NC01-98-0021	2	HEX. BLOC NUT 1 1/4-18
13	NC01-17-0271	8	HEX BOLT GR2 NC ZINC 1/2-13 X 7"
14	NC02-25-0011	8	WASHER SAE ZINC 17/32 ID
15	NC02-07-0020	8	HEX. NUT ZINC 1/2-13

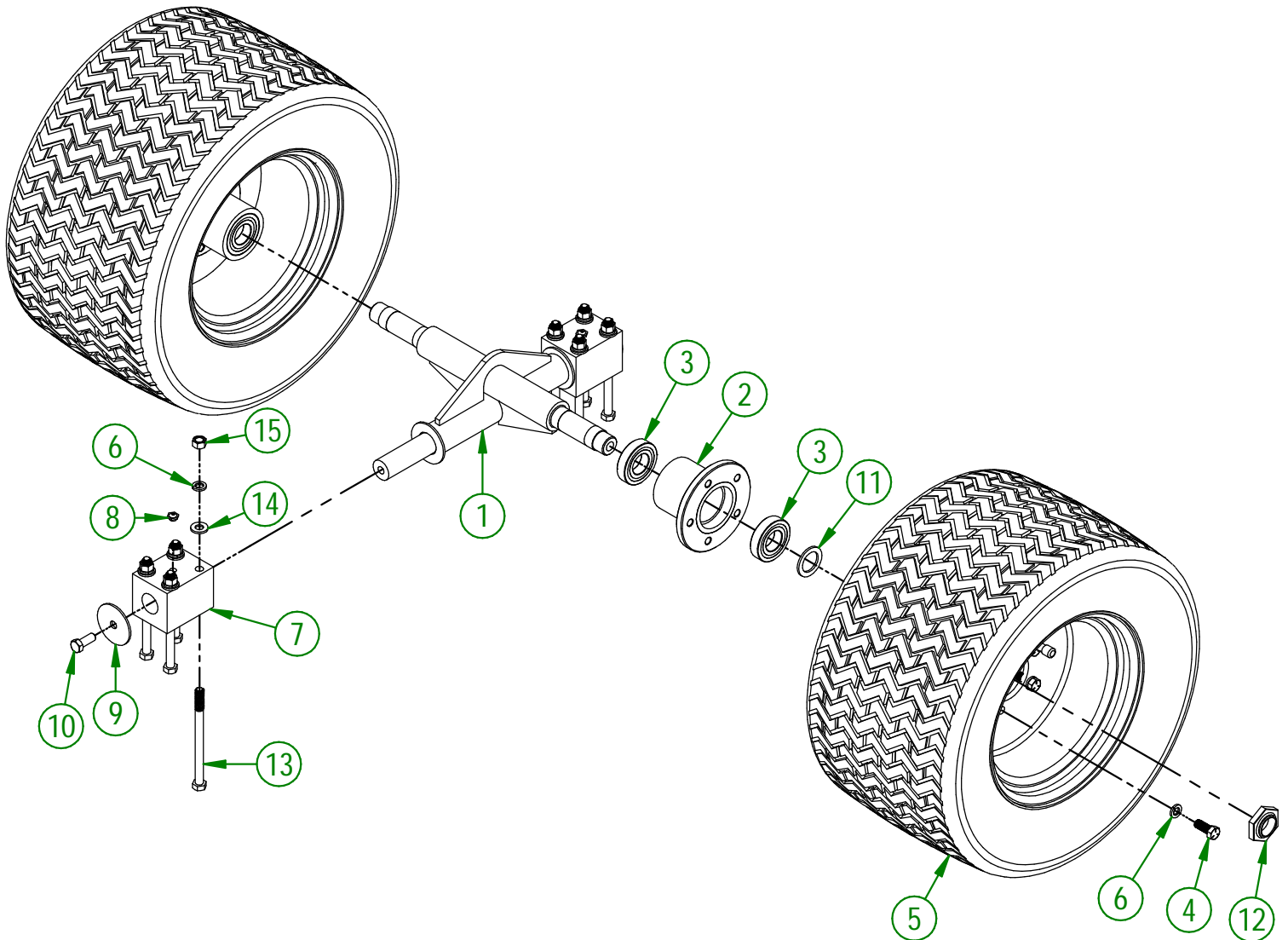

USE THESE PIECES ONLY IF YOUR SERIAL NUMBER IS AFFECTED:

#43816 AND MORE

**AGRIMETAL
AXLE ASSY.**

CREATION : 09/03/23
REVISION : 09/03/23

ASSEMBLY : **28-57-0096**
AUTHOR : J.KABWE

#	PART #	Qty	TITLE
1	29-57-0005	1	BOX "STICKER INCLUDED"
2	NC14-75-0024	4	FLANGE BEARING 4 HOLES UCF207-20 1 1/4" DIA.
3	NC01-17-0259	8	HEX. BOLT GR2 ZINC 1/2-13 X 4"
4	NC02-32-0014	8	LOCK WASHER ZINC 1/2"
5	NC02-07-0020	8	HEX. NUT ZINC 1/2-13
6	28-50-0085	2	BOX PIVOT </td
7	21-01-0950	2	FLAT WASHER 10GA 1.005" DIA X 25/64"
8	NC02-32-0012	2	LOCK WASHER ZINC 3/8"
9	NC01-17-0114	2	HEX. BOLT GR2 ZINC 3/8-16 X 1"
10	28-42-0000	1	CLEAR WITNESS WINDOW
11	29-42-0205	1	SPONGIOUS STICKER

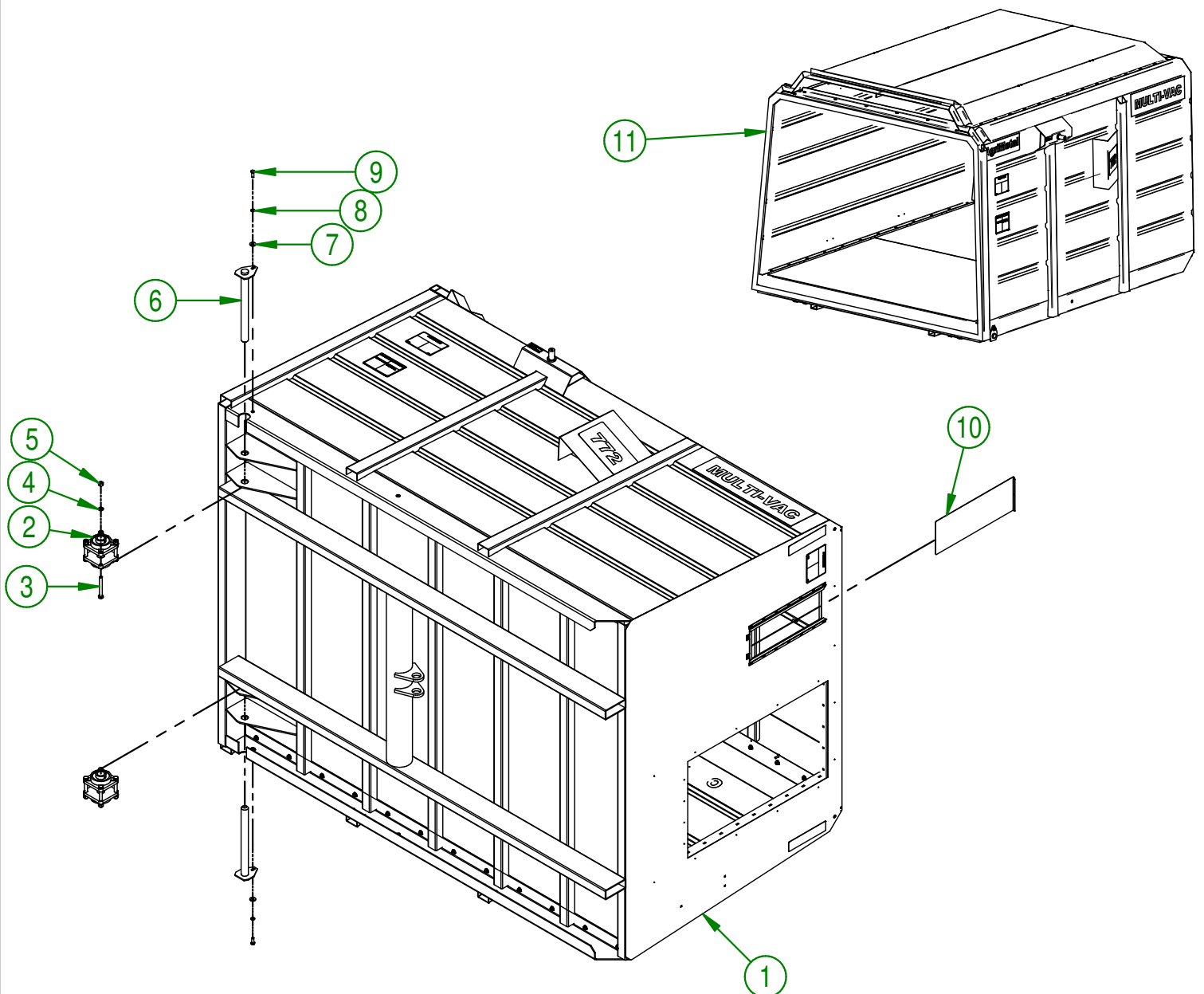

AGRIMETAL
BOX ASSY

CREATION : 04/07/17
REVISION : 07/05/18

ASSEMBLY : **29-57-0006**
AUTHOR : J.KABWE

#	PART #	Qty	TITLE
1	28-04-0015	1	DOOR ADJUSTMENT PLATE
2	NC01-17-0249	2	HEX. BOLT GR2 ZINC 1/2-13 X 1 1/2"
3	NC02-25-0011	2	WASHER SAE ZINC 17/32 ID
4	01-01-1660	2	WASHER SPACER
5	NC02-32-0014	2	LOCK WASHER ZINC 1/2"
6	NC02-07-0020	2	HEX. NUT ZINC 1/2-13
7	NC01-78-0011	1	STABILIZER ATTACHMENT PIN 5/8-18 3 1/8"
8	NC02-22-0013	1	WASHER ZINC 5/8 ID X 1 1/2 OD
9	NC02-32-0016	1	LOCK WASHER ZINC 5/8"

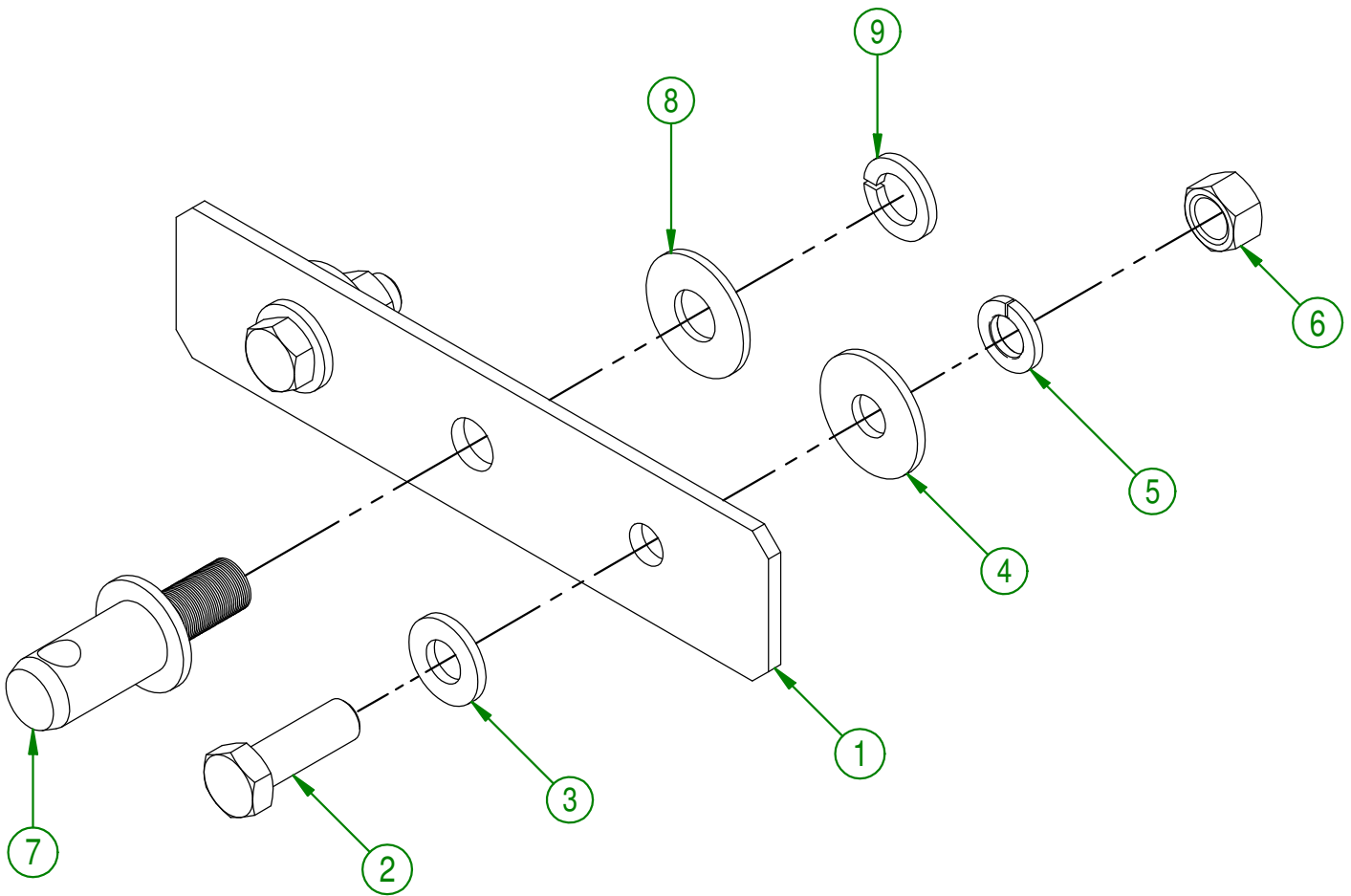

AGRIMETAL	
DOOR ADJUSTMENT PLATE ASSY.	
CREATION : 04/07/17	ASSEMBLY : 28-57-0107
REVISION : 25/01/18	AUTHOR : J.KABWE Page 11 de 72

#	PART #	Qty	TITLE
1	NCI3-45-0161	1	HYDRAULIC CYLINDER
2	28-13-2000	1	HYDRAULIC CYLINDER ROD
3	28-13-2005	1	HYDRAULIC CYLINDER ROD
4	NC01-69-0465	4	ZINC SPRING PIN TENDER DIA. 1/4" X 2" TL
5	NCI3-45-0242	2	90 DEG ELBOW

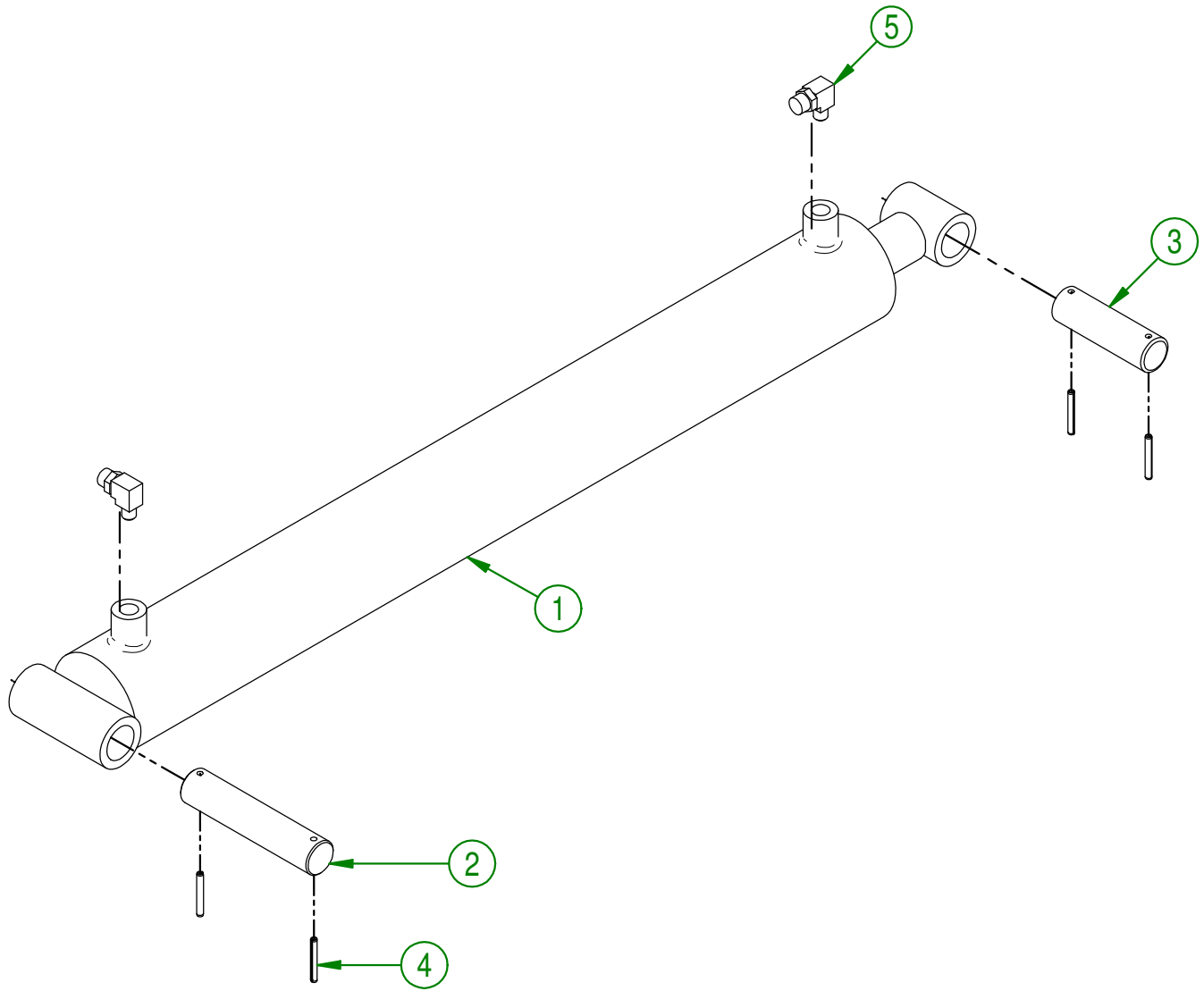

AGRIMETAL	
HYDRAULIC CYLINDER ASSY.	
CREATION : 10/07/17	ASSEMBLY : 28-57-0125
REVISION : 13/03/18	AUTHOR : J.KABWE Page 12 de 72

#	PART #	Qty	TITLE
1	28-50-0055	1	TANDEM LATCH
2	NC01-33-0424	1	HEX. BOLT GR8 NC ZINC 5/8-11 X 9" LG
3	NC01-17-0396	1	HEX. BOLT GR2 ZINC 5/8-11 X 2"
4	NC02-22-0013	1	WASHER ZINC 5/8 ID X 1 1/2 OD
5	NC02-32-0016	1	LOCK WASHER ZINC 5/8"
6	NC02-07-0022	1	HEX. NUT ZINC 5/8-11

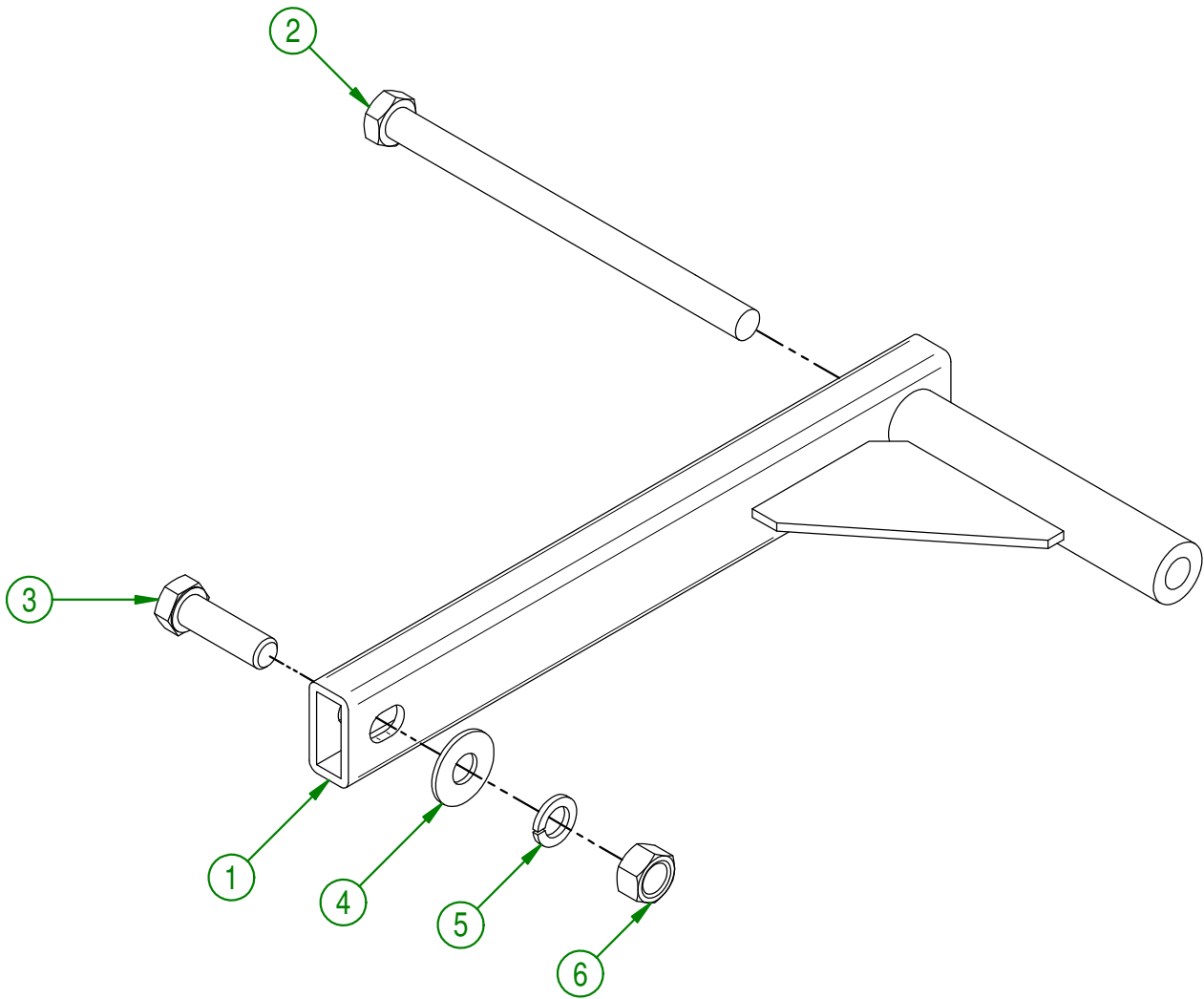

AGRIMETAL	
TANDEM LATCH ASSY.	
CREATION : 03/07/17	ASSEMBLY : 28-57-0097
REVISION : 25/01/18	AUTHOR : J.KABWE Page 13 de 72

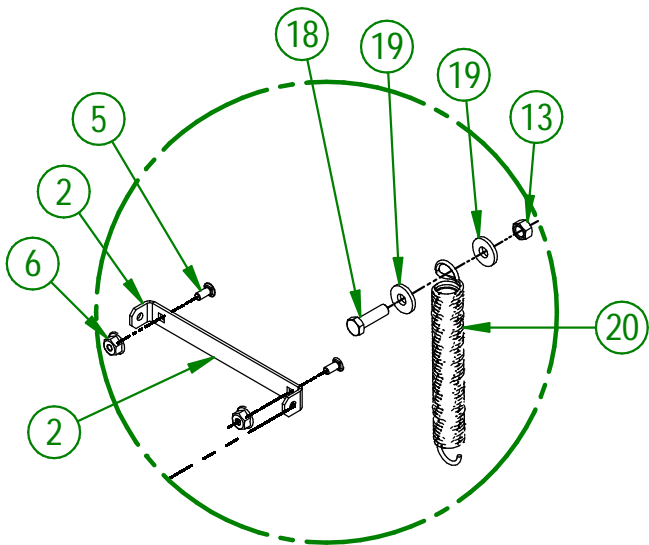
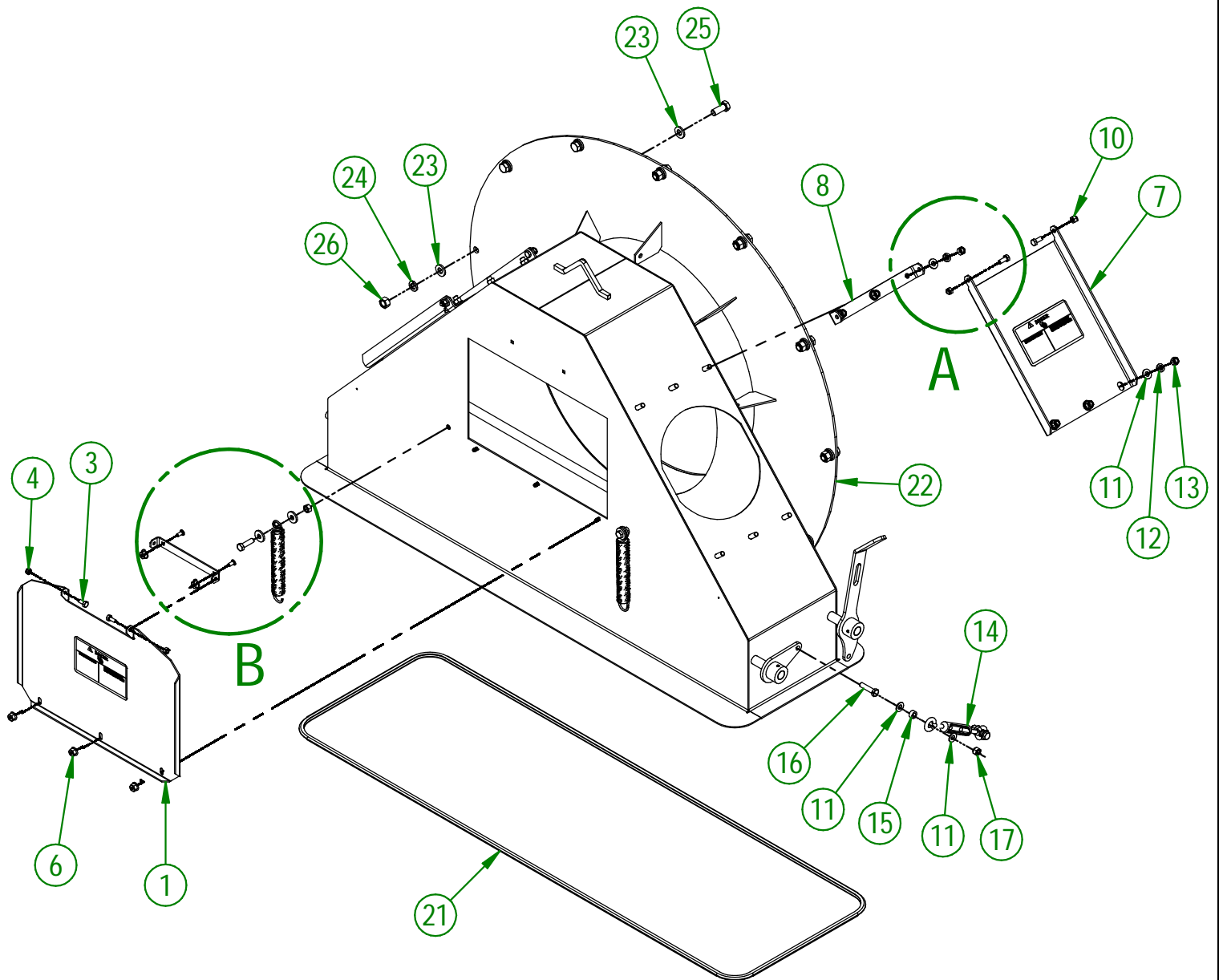

DETAIL B

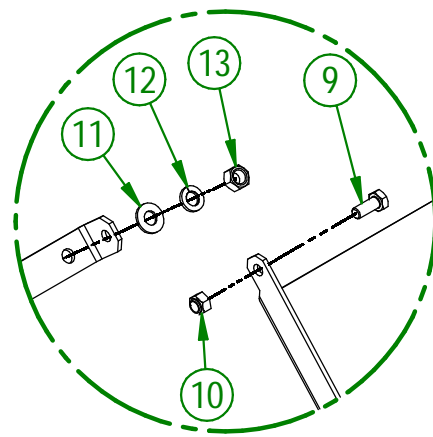

DETAIL A

AGRIMETAL	
SUCTION FUNNEL BOX GROUP.	
CREATION : 27/10/22	ASSEMBLY : 29-57-0023
REVISION : 27/10/22	AUTHOR : J.KABWE

29-57-0023

#	PART #	QTY	TITLE
1	28-57-0051	1	ACCESS DOOR "STICKER INCLUDED" (BACK)
2	28-01-7575	1	ACCESS DOOR HINGE (BACK)
3	NC01-17-0003	2	HEX. BOLT GR2 ZINC 1/4-20 X 5/8"
4	NC01-96-0009	2	NYLON-INSERT LOCKNUT ZINC 1/4-20
5	NC01-04-0001	2	CARR. BOLT GR2 ZINC 1/4-20 X 1/2"
6	NC02-14-0017	5	FLANGED NUT GR. B 1/4-20
7	28-57-0056	2	ACCESS DOOR "STICKER INCLUDED" (RIGHT & LEFT)
8	28-01-1050	2	ACCESS DOOR HINGE (RIGHT & LEFT)
9	NC01-17-0058	4	HEX. BOLT GR2 ZINC 5/16-18 X 3/4"
10	NC01-96-0010	4	NYLON NUT HEX. ZINC 5/16-18
11	01-01-2485	16	FLAT WASHER 14 GA X 13/16"OD X 25/64" ID
12	NC02-32-0012	14	LOCK WASHER ZINC 3/8"
13	NC02-07-0018	16	HEX. NUT ZINC 3/8-16
14	NC01-82-0005	1	TIGHTENER OEIL & OEIL ZINC 5/16"
15	01-09-0005	4	BUSHING
16	NC01-17-0116	2	HEX. BOLT GR2 ZINC 3/8-16 X 1 1/2"
17	NC01-96-0011	2	NYLON NUT 3/8-16
18	NC01-17-0115	2	HEX. BOLT GR2 ZINC 3/8-16 X 1 1/4"
19	21-01-0950	4	FLAT WASHER 10GA 1.005" DIA X 25/64"
20	NC13-85-0040	4	SPRING OUT GALV. .123" WIRE X 1" OD X 8" LENGTH
21	22-46-3750	1	GASKET
22	29-57-0205	1	SUCTION FUNNEL BOX GROUP
23	01-01-0925	22	WASHER
24	NC02-32-0014	12	LOCK WASHER ZINC 1/2"
25	NC01-17-0248	12	HEX. BOLT GR2 ZINC 1/2-13 X 1 1/4"
26	NC02-07-0020	10	HEX. NUT ZINC 1/2-13

#	PART #	Qty	TITLE
1	29-57-0110	1	AIR SUCTION ELBOW "STICKER INCLUDED"
2	29-01-3075	1	AIR DEFLECTOR
3	NC01-04-0001	28	CARR. BOLT GR2 ZINC 1/4-20 X1/2"
4	NC02-14-0017	28	FLANGED NUT GR. B 1/4-20
5	29-01-3100	1	ELBOW SEAL (BOTTOM)
6	29-01-3095	1	ELBOW SEAL (TOP)
7	29-01-3090	1	ELBOW SEAL (LEFT)
8	29-01-3093	1	ELBOW SEAL (RIGHT)
9	NC01-78-0016	14	ALUMINIUM BLIND POP RIVET STEEL MANDREL 0.187 X 0.690
10	16-01-2720	14	WASHER 13/16" DIA. X 13/64"

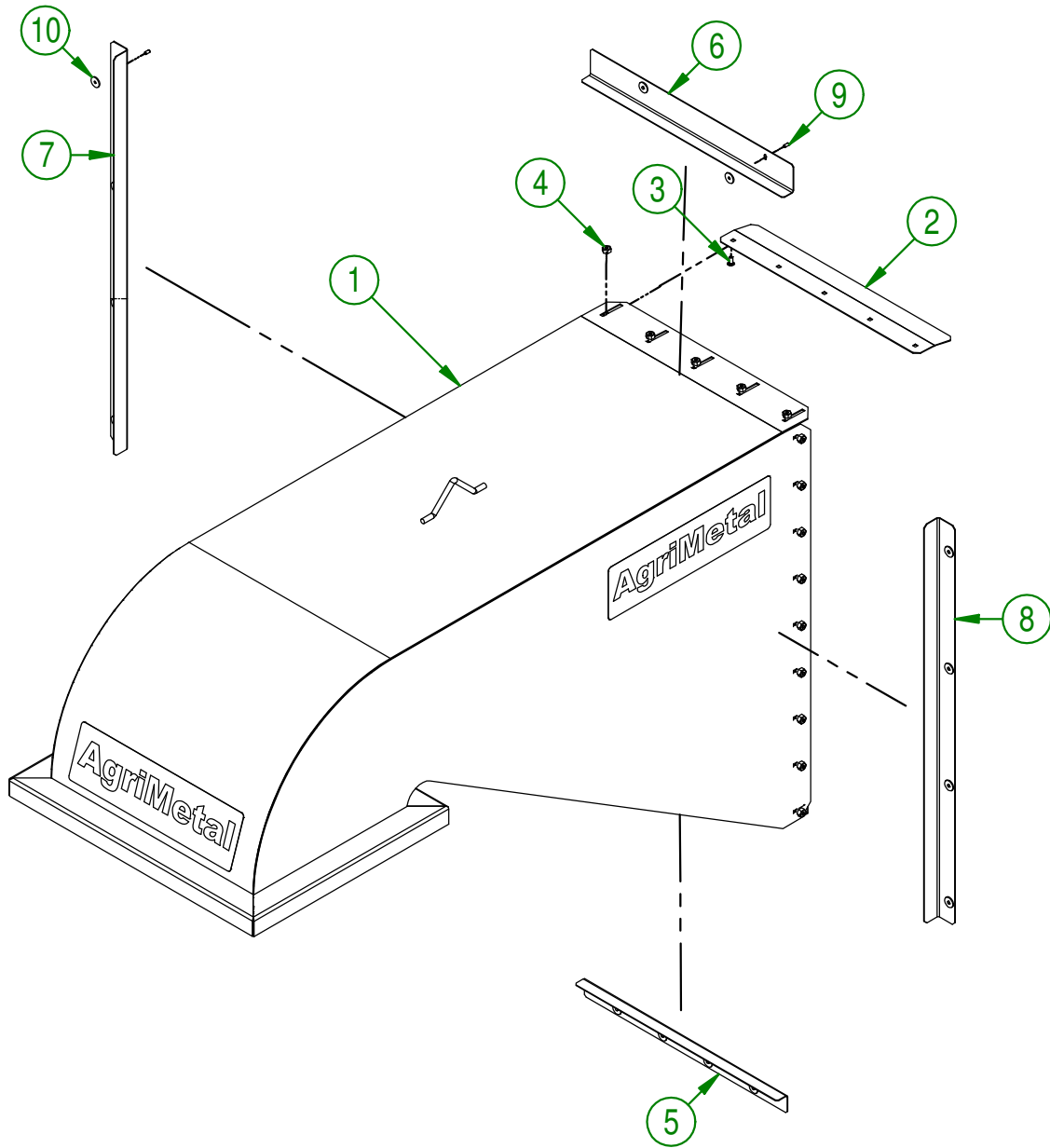

AGRIMETAL	
AIR SUCTION ELBOW ASSY.	
CREATION : 14/07/17	ASSEMBLY : 29-57-0111
REVISION : 26/01/18	AUTHOR : J.KABWE Page 17 de 72

28-57-0100

#	PART #	Qty	TITLE
1	28-55-0355	1	BALL BEARING BASE " 2B124 GEAR BOX TENDER"
2	01-01-1660	4	WASHER SPACER
3	NC01-17-0257	2	HEX. BOLT GR2 ZINC 1/2-13 X 3 1/2"
4	NC02-32-0014	2	LOCK WASHER ZINC 1/2"
5	NC02-07-0020	2	HEX. NUT ZINC 1/2-13

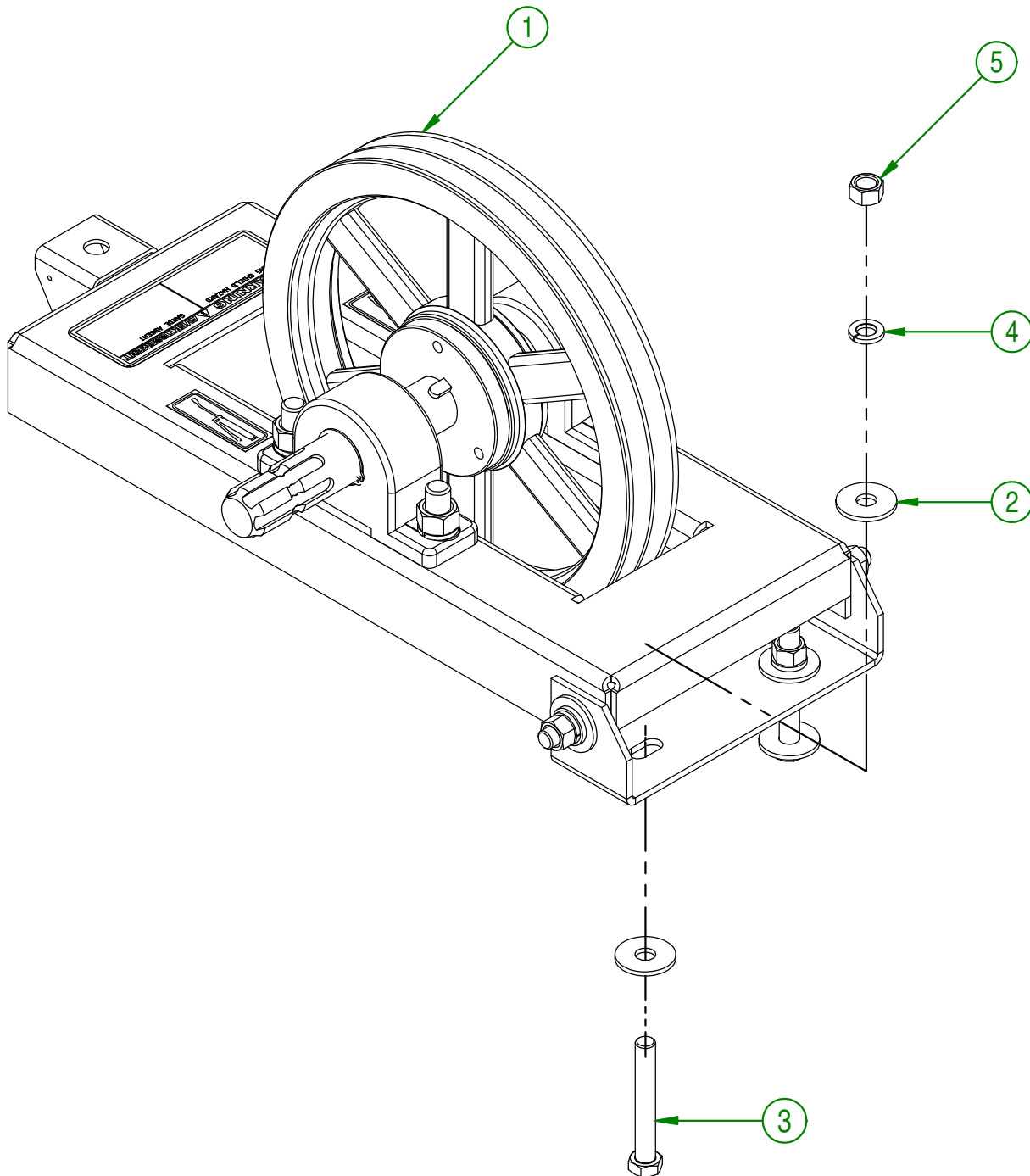

AGRIMETAL	
BALL BEARING BASE " GEAR BOX TENDER" ASSY.	
CREATION : 31/03/17	ASSEMBLY : 28-57-0100
REVISION : 25/01/18	AUTHOR : J.KABWE Page 18 de 72

28-55-0355

#	PART #	Qty	TITLE
1	28-57-0075	1	BEARING BASE GROUP.
2	28-55-0185	1	2B124 SK X I 3/8" KW PULLEY
3	28-41-0905	1	SQUARE KEY ROUND END
4	NC14-75-0113	2	PILLOW BLOCK UCP207-22 I 3/8" DIA. JAPAN ONLY
5	NC01-17-0396	4	HEX. BOLT GR2 ZINC 5/8-11 X 2"
6	NC02-32-0016	4	LOCK WASHER ZINC 5/8"
7	NC02-07-0022	4	HEX. NUT ZINC 5/8-11
8	28-20-0060	1	AUXILARY TRAINING SHAFT
9	NC01-64-0018	2	EXTERNAL RETAINING RING I 3/8" DIA. ROD
10	29-04-0400	2	PILLOW BLOCK GUIDE
11	NC02-22-0012	2	WASHER ZINC 1/2 BOLT = 9/16"Ø X I 3/8" OD
12	NC02-32-0014	2	LOCK WASHER ZINC 1/2"
13	NC01-25-0249	2	HEX. BOLT GR5 ZINC 1/2-13 X I 1/2" LG

28-55-0185

#	PART #	Qty	TITLE
14	NC14-62-0094	1	CAST IRON PULLEY 2B124
15	NC14-62-0020	1	TAPERED QD BUSHING SK I 3/8"

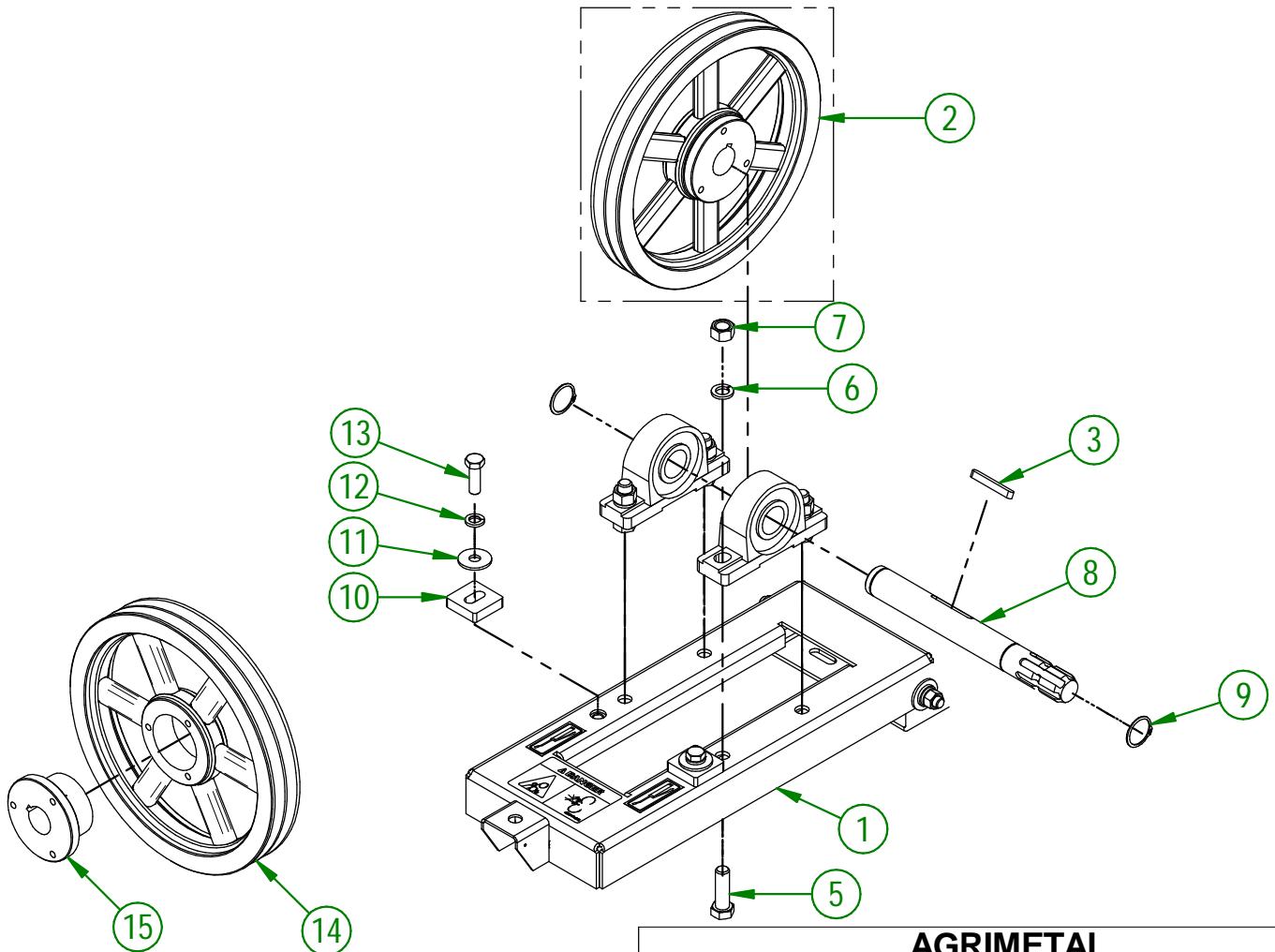

AGRIMETAL	
BALL BEARING BASE " 2B124 GEAR BOX TENDER"	
CREATION : 31/03/17	ASSEMBLY : 28-55-0355
REVISION : 16/12/25	AUTHOR : J.KABWE

28-57-0120

#	PART #	Qty	TITLE
1	28-55-0190	1	90° ANGLE GEAR BOX
2	NC02-25-0011	4	WASHER SAE ZINC 17/32 ID
3	NC02-32-0014	4	LOCK WASHER ZINC 1/2"
4	NC01-45-0258	4	GR8.8 METR. BOLT 12MM X 1.75 PITCH X 35MM

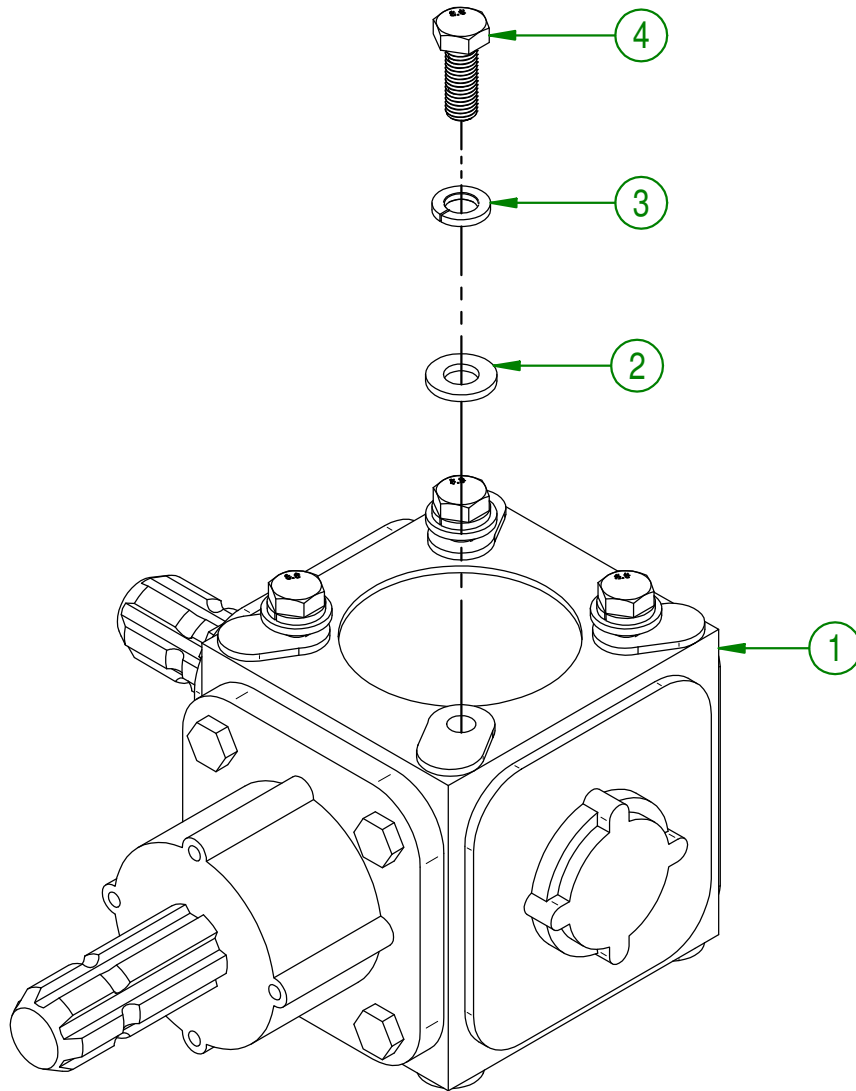

AGRIMETAL	
90° ANGLE GEAR BOX GROUP.	
CREATION : 30/03/17	ASSEMBLY : 28-57-0120
REVISION : 25/01/18	AUTHOR : J.KABWE Page 20 de 72

	REF.	DESIGNATION	T-19 A
	DATE	14-04-2008	CODE

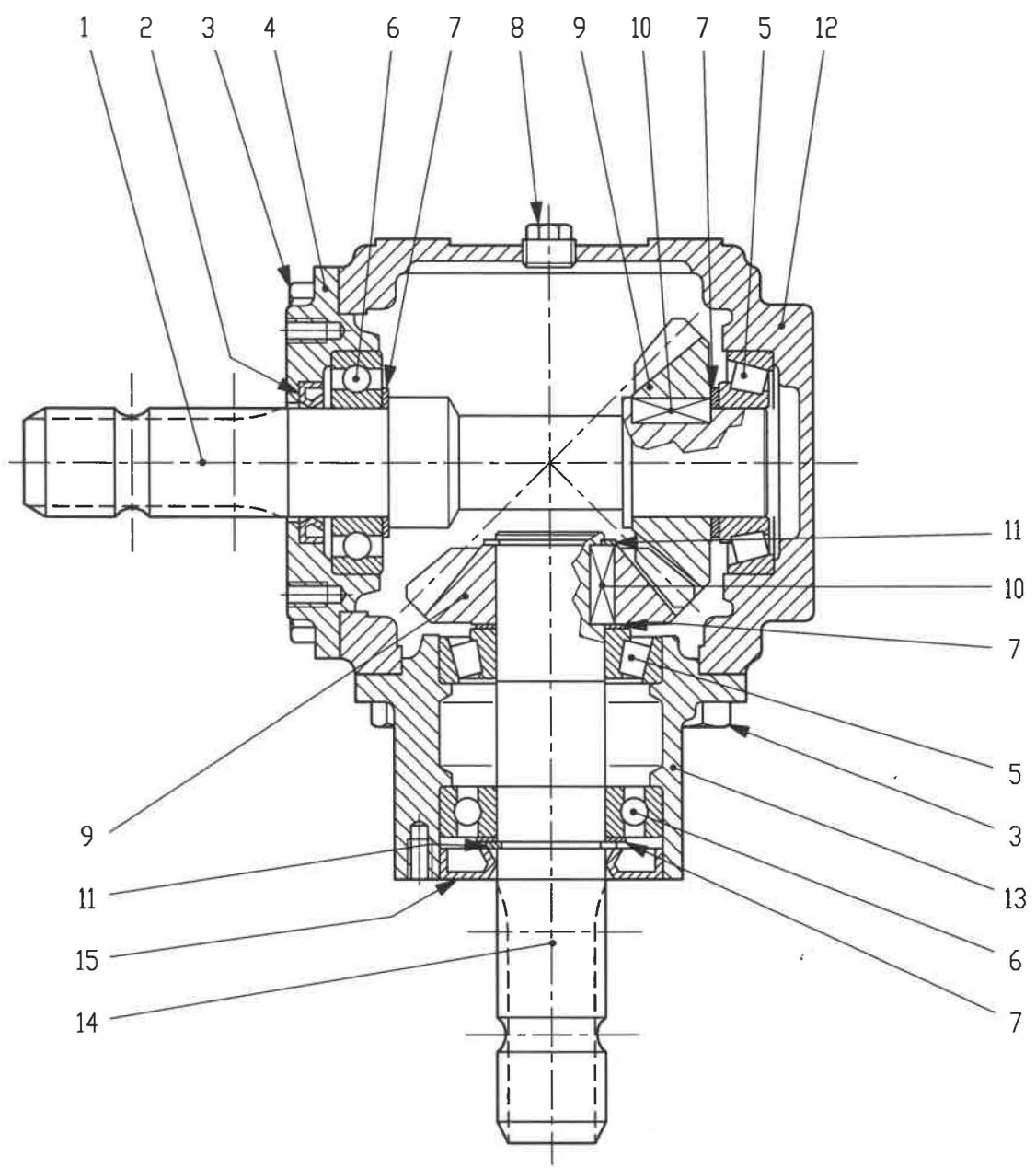

POS.	DRG. N.	PIEC	DESCRIPTION
1	0.259.3106.00	1	SHAFT 1"3/8
2	8.7.3.00028	1	OIL SEAL 35X52X7
3	8.1.1.00090	8	BOLT M12X25 8,8
4	0.259.1305.00	1	COVER
5	8.0.9.00026	2	BEARING 30207
6	8.0.1.00025	2	BEARING 6207
7	0.259.7500.00	4	SHIM 35.3x48.0
8	8.6.5.00006	1	PLUG 3/8"GAS
9	0.259.5020.00	2	GEAR Z18 M5
10	8.4.1.00232	2	PARALLEL KEY A 10X8X25
11	8.5.1.00005	2	SNAP RING 35 UNI7435
12	0.259.0300.00	1	CASING
13	0.259.1300.00	1	EXTENSION
14	0.259.2100.01	1	SHAFT
15	8.7.3.00055	1	OIL SEAL 35X72X10

28-57-0130

#	PART #	Qty	TITLE
1	28-55-0385	1	HYDRAULIC CYLINDER " PICK UP HEAD" ASSY
2	28-13-2015	1	HYDRAULIC CYLINDER HOLDER
3	28-01-0930	2	TANDEM END PLAT WASHER
4	NC02-32-0014	2	LOCK WASHER ZINC 1/2"
5	NC01-17-0247	2	HEX. BOLT GR2 ZINC 1/2-13 X 1"
6	NC01-96-0016	1	NYLON INSERT NUT 5/8-11

28-55-0385

#	PART #	Qty	TITLE
7	28-50-0110	1	PICK UP HEAD HYDRAULIC CYLINDER
8	NC13-45-0263	1	90° ELBOW 1/4 MALE NPT X 1/4 MALE NPT
9	NC13-45-0191	1	TURF ROLLER
10	NC13-45-0189	2	RIGHT UNION 1/4" X MALE NPT X 1/4" MALE JIC
11	NC13-45-0214	2	RIGHT UNION 7/16-20 MALE SAE4 ORING X 1/4 FEM. NPT

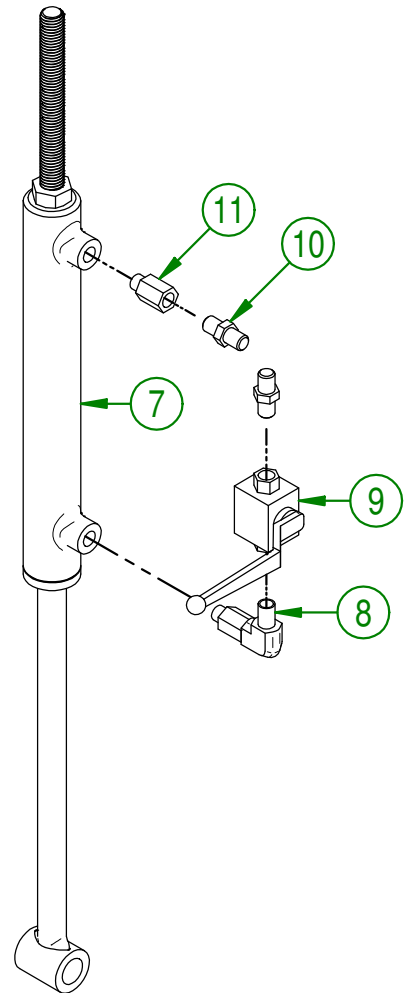
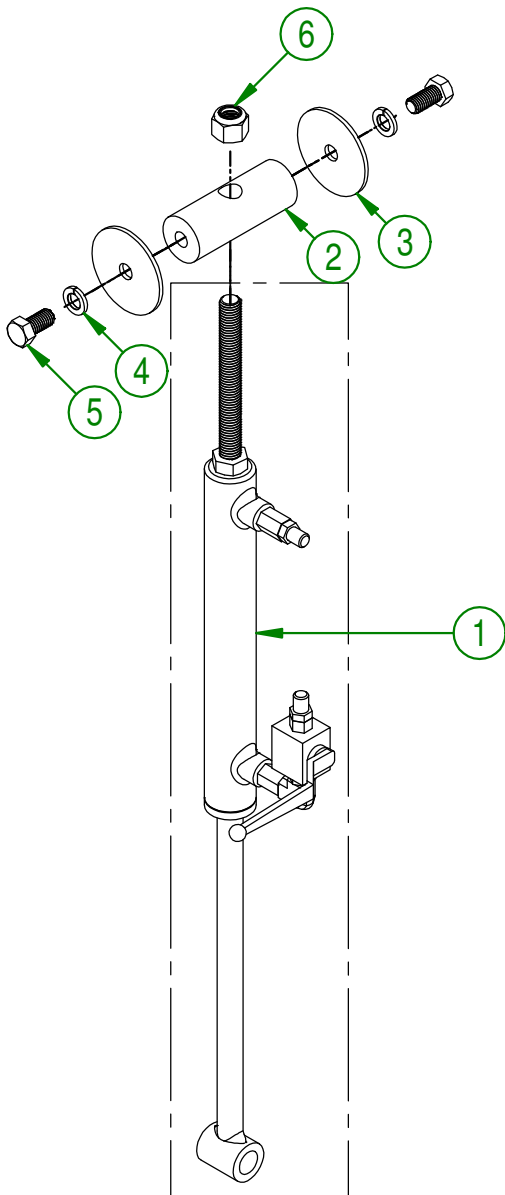

AGRIMETAL	
PICK UP HEAD HYDRAULIC CYLINDER	
CREATION : 10/07/17	ASSEMBLY : 28-57-0130
REVISION : 25/01/18	AUTHOR : J.KABWE Page 23 de 72

#	PART #	Qty	TITLE
1	28-42-0150	1	HYDRAULIC CYLINDER GUARD
2	NC01-04-0001	2	CARR. BOLT GR2 ZINC 1/4-20 X1/2"
3	NC02-14-0017	2	FLANGED NUT GR. B 1/4-20

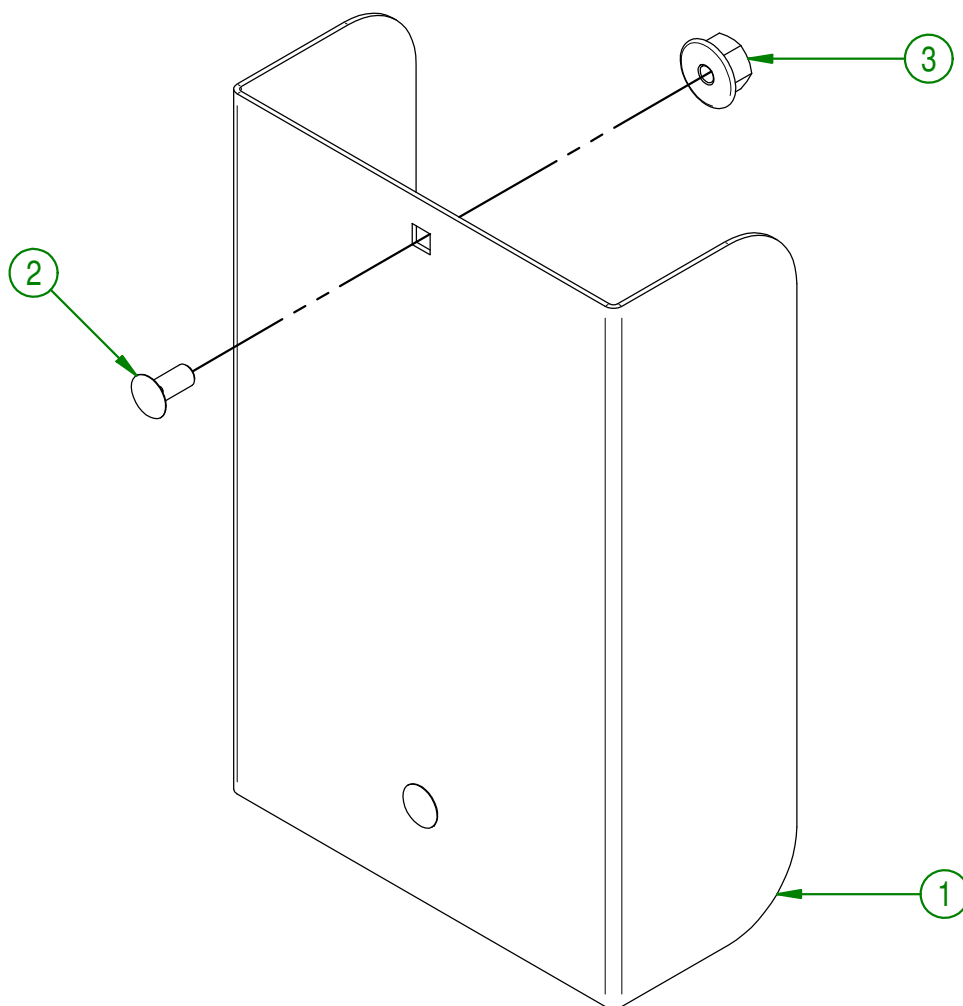

AGRIMETAL	
HYDRAULIC CYLINDER GUARD	
CREATION : 31/03/17	ASSEMBLY : 28-57-0135
REVISION : 25/01/18	AUTHOR : J.KABWE Page 24 de 72

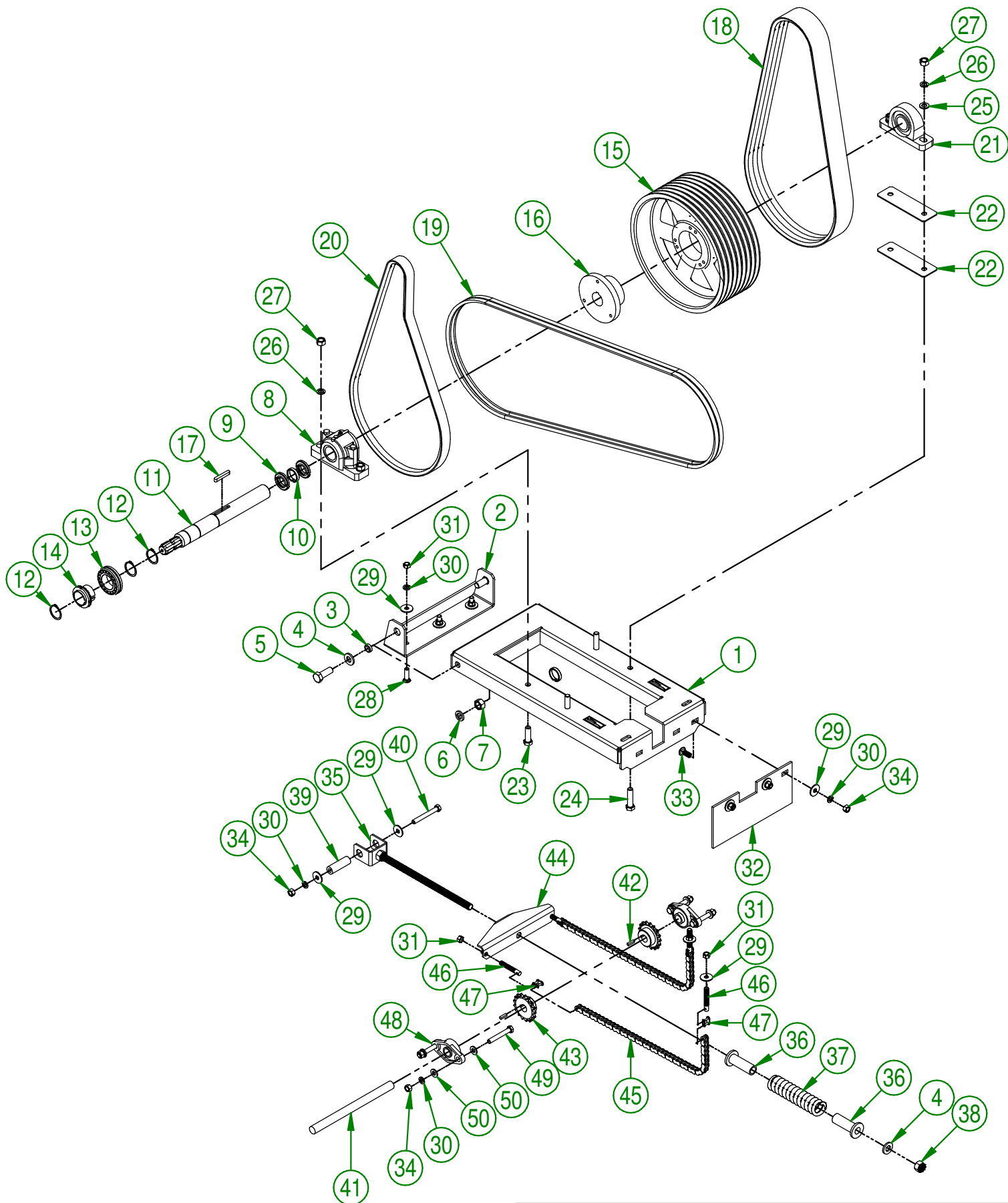

USE THESE PIECES ONLY IF YOUR SERIAL NUMBER IS AFFECTED:

#41343 AND UNDER

AGRIMETAL

8B154 BEARING BASE " STICKER INCLUDED"

CREATION : 22/11/17
REVISION : 02/11/21

ASSEMBLY : **29-57-0070**
AUTHOR : J.KABWE

29-57-0070

#	PART #	Qty	TITLE
1	28-57-0071	1	BEARING BASE "STICKER INCLUDED"
2	28-50-0285	1	8 V BELT ADJUSTABLE HINGE
3	22-09-1200	2	BUSHING
4	22-04-6805	3	FLAT WASHER BEARING BASE
5	NC01-17-0467	2	HEX. BOLT GR2 ZINC 3/4-10 X 2"
6	NC02-32-0017	2	LOCK WASHER ZINC 3/4"
7	NC02-07-0023	2	HEX. NUT ZINC 3/4-10
8	32-38-0000	1	INNER SHAFT CAST CASING
9	NC14-75-0123	1	SET JOINT I 3/4"
10	NC14-75-0122	2	BEARING SPACER I 3/4"
11	28-20-0070	1	IMPELLER SHAFT
12	NC01-64-0026	3	RETAINING RING I 3/4"
13	NC14-75-0125	1	BEARING SNK I 3/4"
14	NC14-75-0126	1	TAPER ADAPTER I 3/4"
15	NC14-62-0203	1	CAST IRON SHAVE PULLEY 8B154 E
16	NC14-62-0192	1	TAPERED QD BUSHING E I /3
17	28-41-0900	1	SQUARE KEY 3/8" X 3/8" X 2 1/2"
18	NC14-25-4591	1	V BELT 4RB-77 (5/8" X 80")
19	NC14-25-0613	2	V EBLT B-104 (5/8" X 107")
20	NC14-25-2386	1	V BELT 2RB-73 (5/8" X 76")
21	32-38-0005	1	BEARING UCP 209-28 Ø I 3/4"
22	28-01-1655	2	BEARING SHIM
23	NC01-17-0396	2	HEX. BOLT GR2 ZINC 5/8-11 X 2"
24	NC01-17-0398	2	HEX. BOLT GR2 NC ZINC 5/8-11 X 2 1/2"
25	32-01-1395	2	BEARING WHASER Ø 3/4"
26	NC02-32-0016	4	LOCK WASHER ZINC 5/8"
27	NC02-07-0022	4	HEX. NUT ZINC 5/8-11
28	NC01-04-0235	3	CARR. BOLT GR2 ZINC 1/2-13 X I 1/2"
29	01-01-1660	10	WASHER SPACER
30	NC02-32-0014	11	LOCK WASHER ZINC 1/2"
31	NC01-96-0014	7	NYLON-INSERT LOCKNUT ZINC 1/2-13
32	28-04-0335	1	STOPPER PLATE
33	NC01-04-0234	3	CARR. BOLT GR2 ZINC 1/2-13 X I 1/4
34	NC02-07-0020	8	HEX. NUT ZINC 1/2-13
35	28-50-0130	1	BELT-TIGHTENER
36	28-42-0135	2	SPRING CAP
37	12-44-0010	1	SPRING 2" DIA. X 8"
38	NC01-96-0017	1	HEX. LOCK NUT NYLO. NC 3/4-10
39	28-09-1210	1	BELT-TIGHTENER PIVOT
40	NC01-17-0259	1	HEX. BOLT GR2 ZINC 1/2-13 X 4"
41	28-13-1440	1	TENSION STABILIZING SHAFT

AGRIMETAL

8B154 BEARING BASE " STICKER INCLUDED"

CREATION : 22/11/17

REVISION : 02/11/21

ASSEMBLY : **29-57-0070**

AUTHOR : J.KABWE

29-57-0070

#	PART #	Qty	TITLE
42	16-41-0900	2	SQUARE KEY 1/4" X 1/4" X 1"
43	NC14-55-0239	2	SPROCKET 50B17 X 1" KW 1/4 2SS 5/16-18
44	28-50-0105	1	TIGHTENER STABILIZING
45	28-37-1000	2	CHAIN #50 X 25"
46	28-13-0605	4	CHAIN FERRULE 50-1
47	NC14-20-0028	4	CHAIN 50 MMC (MESH)
48	01-38-0000	2	FLANGE BEARING UCFL 205-16 X 1" DIA.
49	NC01-17-0257	4	HEX. BOLT GR2 ZINC 1/2-13 X 3 1/2"
50	NC02-25-0011	8	WASHER SAE ZINC 17/32 ID

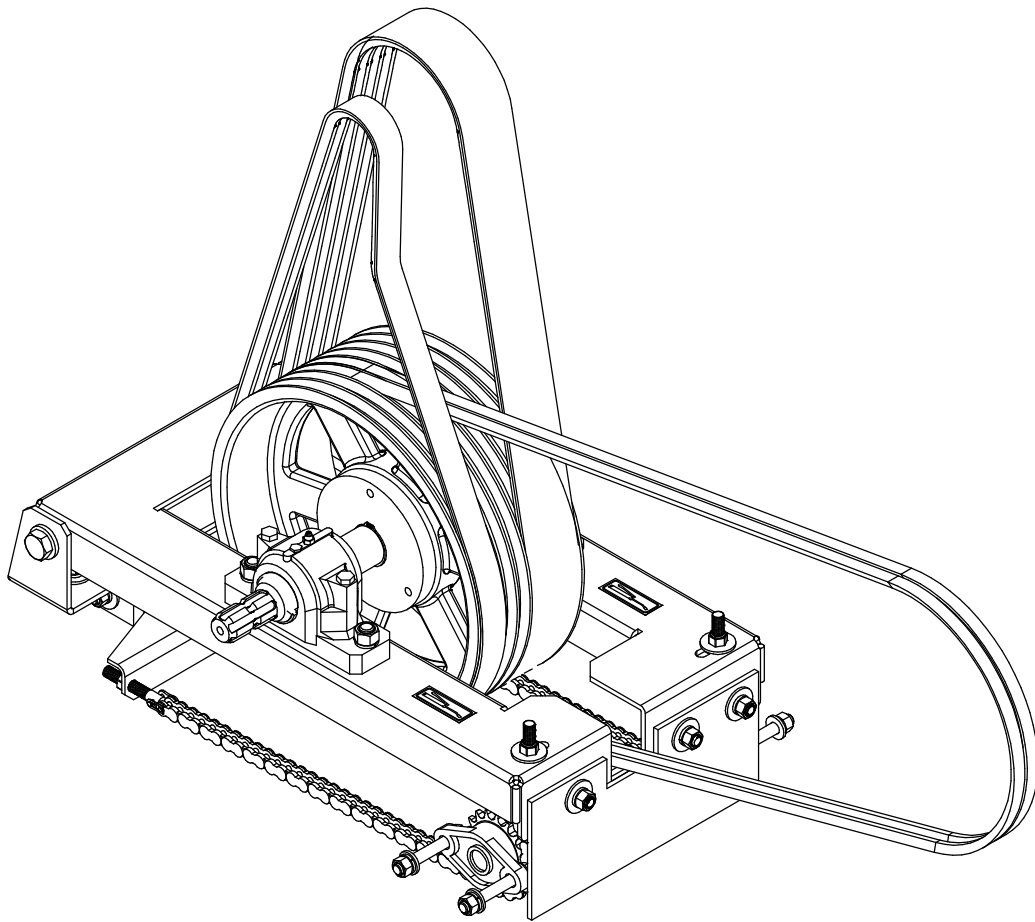

AGRIMETAL

8B154 BEARING BASE " STICKER INCLUDED"

CREATION : 22/11/17
 REVISION : 02/11/21

ASSEMBLY : **29-57-0070**
 AUTHOR : J.KABWE

IF YOU ORDER #18 BELT, YOU MUST ORDER THE 29-57-9000 REPLACEMENT KIT WITH YOUR BELT TO FACILITATE INSTALLATION

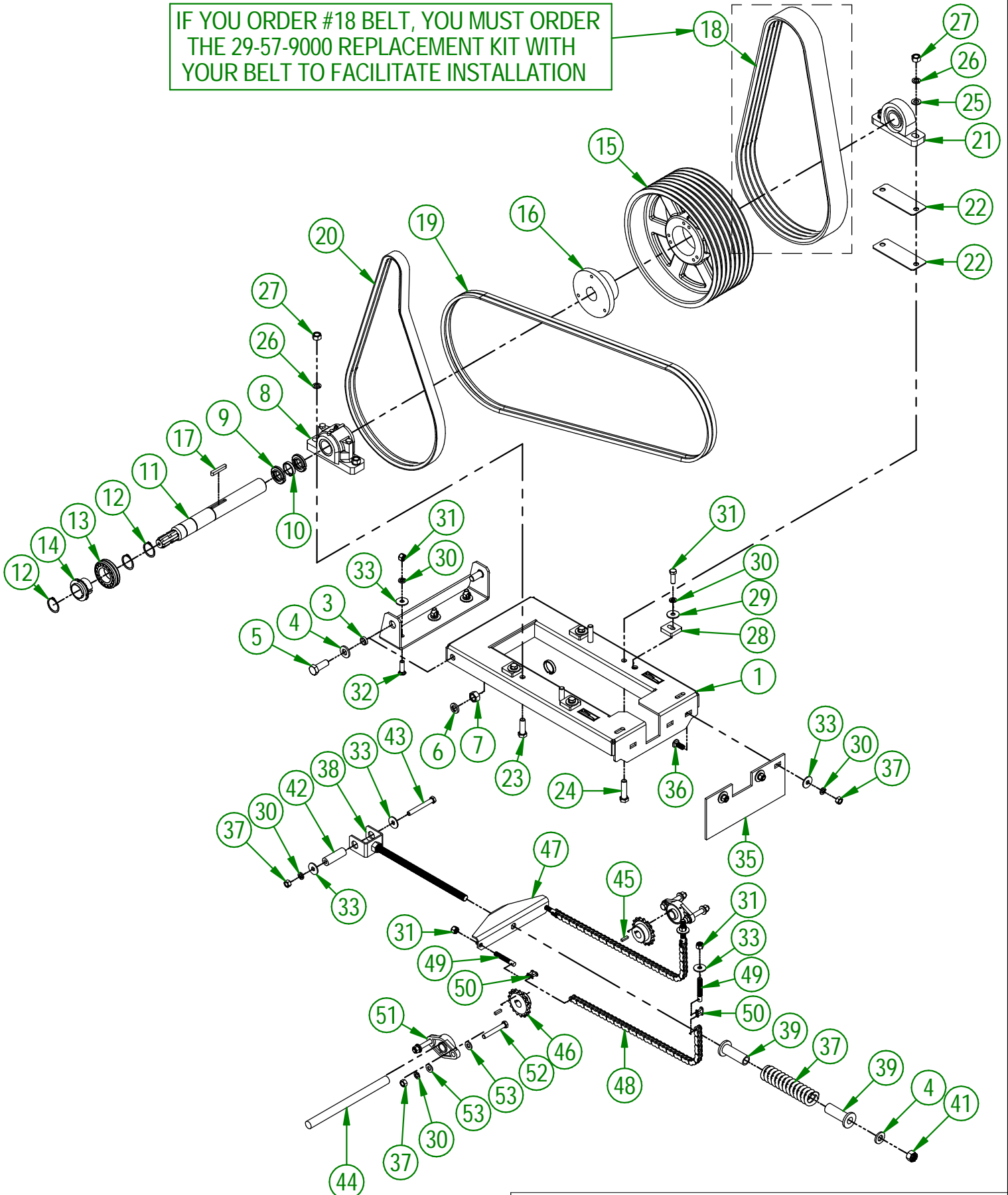

USE THESE PIECES ONLY IF YOUR SERIAL NUMBER IS AFFECTED:

BETWEEN #41344 AND #48699

AGRIMETAL

8B154 BEARING BASE " STICKER INCLUDED"

CREATION : 02/11/21
REVISION : 12/02/26

ASSEMBLY : **29-57-0071**
AUTHOR : J.KABWE

#	PART #	Qty	TITLE
1	28-57-0071	1	BEARING BASE "STICKER INCLUDED"
2*	28-50-0285	1	8 V BELT ADJUSTABLE HINGE
3	22-09-1200	2	BUSHING
4	22-04-6805	3	FLAT WASHER BEARING BASE
5	NC01-17-0467	2	HEX. BOLT GR2 ZINC 3/4-10 X 2"
6	NC02-32-0017	2	LOCK WASHER ZINC 3/4"
7	NC02-07-0023	2	HEX. NUT ZINC 3/4-10
8	32-38-0000	1	INNER SHAFT CAST CASING
9	NC14-75-0123	1	SET JOINT I 3/4"
10	NC14-75-0122	2	BEARING SPACER I 3/4"
11	28-20-0070	1	IMPELLER SHAFT
12	NC01-64-0026	3	RETAINING RING I 3/4"
13	NC14-75-0125	1	BEARING SNK I 3/4"
14	NC14-75-0126	1	TAPER ADAPTER I 3/4"
15	NC14-62-0203	1	CAST IRON SHAVE PULLEY 8BI54 E
16	NC14-62-0192	1	TAPERED QD BUSHING E I /3
17	28-41-0900	1	SQUARE KEY 3/8" X 3/8" X 2 1/2"
18	NC14-25-4388	1	V BELT 4RB-75
19	NC14-25-0613	2	V EBLT B-104 (5/8" X 107")
20	NC14-25-2386	1	V BELT 2RB-73 (5/8" X 76")
21	NC14-75-0115	1	PILLOW BLOCK UCP209-28 Ø I 3/4"
22	28-01-1655	2	BEARING SHIM
23	NC01-17-0396	2	HEX. BOLT GR2 ZINC 5/8-11 X 2"
24	NC01-17-0398	2	HEX. BOLT GR2 NC ZINC 5/8-11 X 2 1/2"
25	32-01-1395	2	BEARING WHASER Ø 3/4"
26	NC02-32-0016	4	LOCK WASHER ZINC 5/8"
27	NC02-07-0022	4	HEX. NUT ZINC 5/8-11
28	29-04-0400	4	PILLOW BLOCK GUIDE
29	NC02-22-0012	4	WASHER ZINC 1/2 BOLT = 9/16"Ø X I 3/8" OD
30	NC02-32-0014	15	LOCK WASHER ZINC 1/2"
31	NC01-25-0249	4	HEX. BOLT GR5 ZINC 1/2-13 X I 1/2" LG
32	NC01-04-0235	3	CARR. BOLT GR2 ZINC 1/2-13 X I 1/2"
33	01-01-1660	10	WASHER SPACER
34	NC01-96-0014	7	NYLON-INSERT LOCKNUT ZINC 1/2-13
35	28-04-0335	1	STOPPER PLATE
36	NC01-04-0234	3	CARR. BOLT GR2 ZINC 1/2-13 X I 1/4
37	NC02-07-0020	8	HEX. NUT ZINC 1/2-13
38	28-50-0130	1	BELT-TIGHTENER
39	28-42-0135	2	SPRING CAP
40	12-44-0010	1	SPRING 2" DIA. X 8"
41	NC01-96-0017	1	HEX. LOCK NUT NYLO. NC 3/4-10

AGRIMETAL

8B154 BEARING BASE " STICKER INCLUDED"

CREATION : 02/11/21
REVISION : 12/02/26

ASSEMBLY : **29-57-0071**
AUTHOR : J.KABWE

#	PART #	Qty	TITLE
42	28-09-1210	1	BELT-TIGHTENER PIVOT
43	NC01-17-0259	1	HEX. BOLT GR2 ZINC 1/2-13 X 4"
44	28-13-1440	1	TENSION STABILIZING SHAFT
45	NC01-65-0095	2	SQUARE KEY 1/4" X 1"
46	NC14-55-0239	2	SPROCKET 50B17 X 1" KW 1/4 2SS 5/16-18
47	28-50-0105	1	TIGHTENER STABILIZING
48	28-37-1000	2	CHAIN #50 X 25"
49	28-13-0605	4	CHAIN FERRULE 50-1
50	NC14-20-0028	4	CHAIN 50 MMC (MESH)
51	01-38-0000	2	FLANGE BEARING UCFL 205-16 X 1" DIA.
52	NC01-17-0257	4	HEX. BOLT GR2 ZINC 1/2-13 X 3 1/2"
53	NC02-25-0011	8	WASHER SAE ZINC 17/32 ID

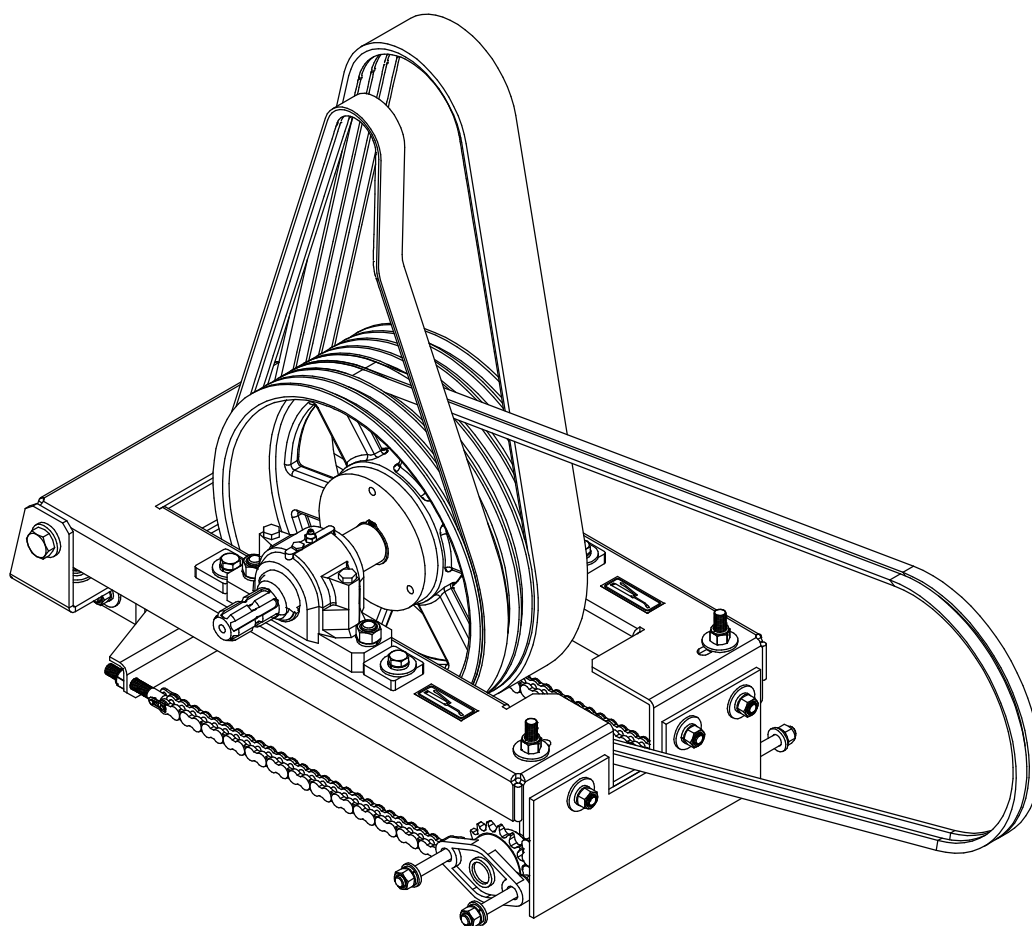

AGRIMETAL

8B154 BEARING BASE " STICKER INCLUDED"

CREATION : 02/11/21
REVISION : 12/02/26

ASSEMBLY : **29-57-0071**
AUTHOR : J.KABWE

#	PART #	Qty	TITLE
1	28-21-0020	1	IDLER PULLEY ONLY
2	NC14-75-0068	2	BALL BEARING 99502H
3	NC01-64-0142	1	SNAP RING HOLE 1 3/8"
4	28-21-0010	1	IDLER PULLEY BUSHING
5	21-01-0950	1	FLAT WASHER 10GA 1.005" DIA X 25/64"
6	28-50-0095	1	BELT-TIGHTENER ARM
7	01-01-2485	1	FLAT WASHER
8	NC01-04-0116	1	CARR. BOLT GR2 ZINC 3/8-16 X 2 3/4"
9	NC02-32-0012	1	LOCK WASHER ZINC 3/8"
10	NC02-07-0018	1	HEX. NUT ZINC 3/8-16
11	NC13-85-0026	1	SPRING GALVANIZED 0.120"W X 1.050"OD X 6"
12	NC02-25-0011	3	WASHER SAE ZINC 17/32 ID
13	NC01-17-0253	1	HEX. BOLT GR2 ZINC 1/2-13 X 2 1/2"
14	NC02-32-0014	1	LOCK WASHER ZINC 1/2"
15	NC01-96-0014	1	NYLON-INSERT LOCKNUT ZINC 1/2-13

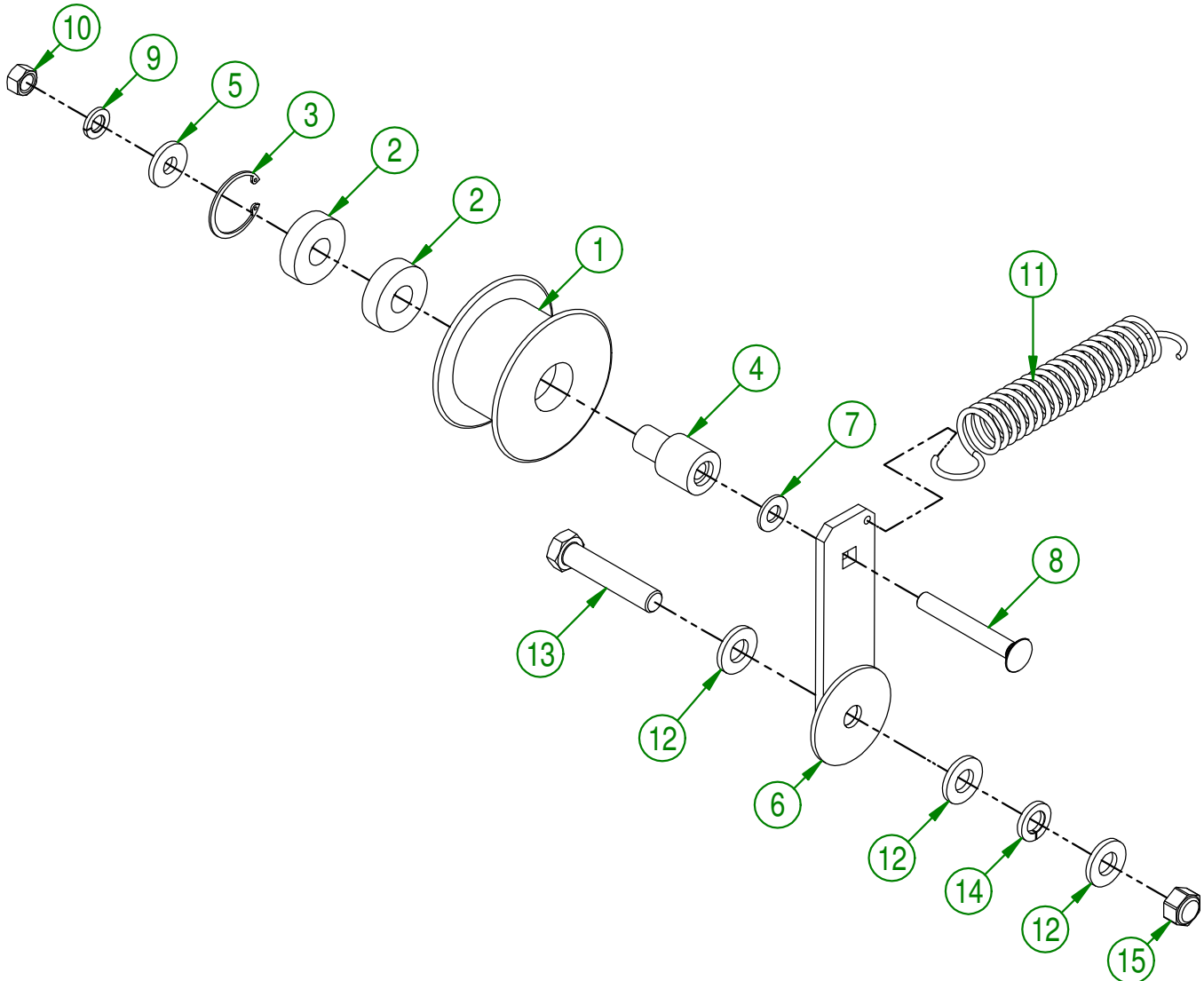

AGRIMETAL	
FRONT BLOWER TIGHTENER	
CREATION : 22/11/17	ASSEMBLY : 28-57-0150
REVISION : 25/01/18	AUTHOR : J.KABWE Page 28 de 72

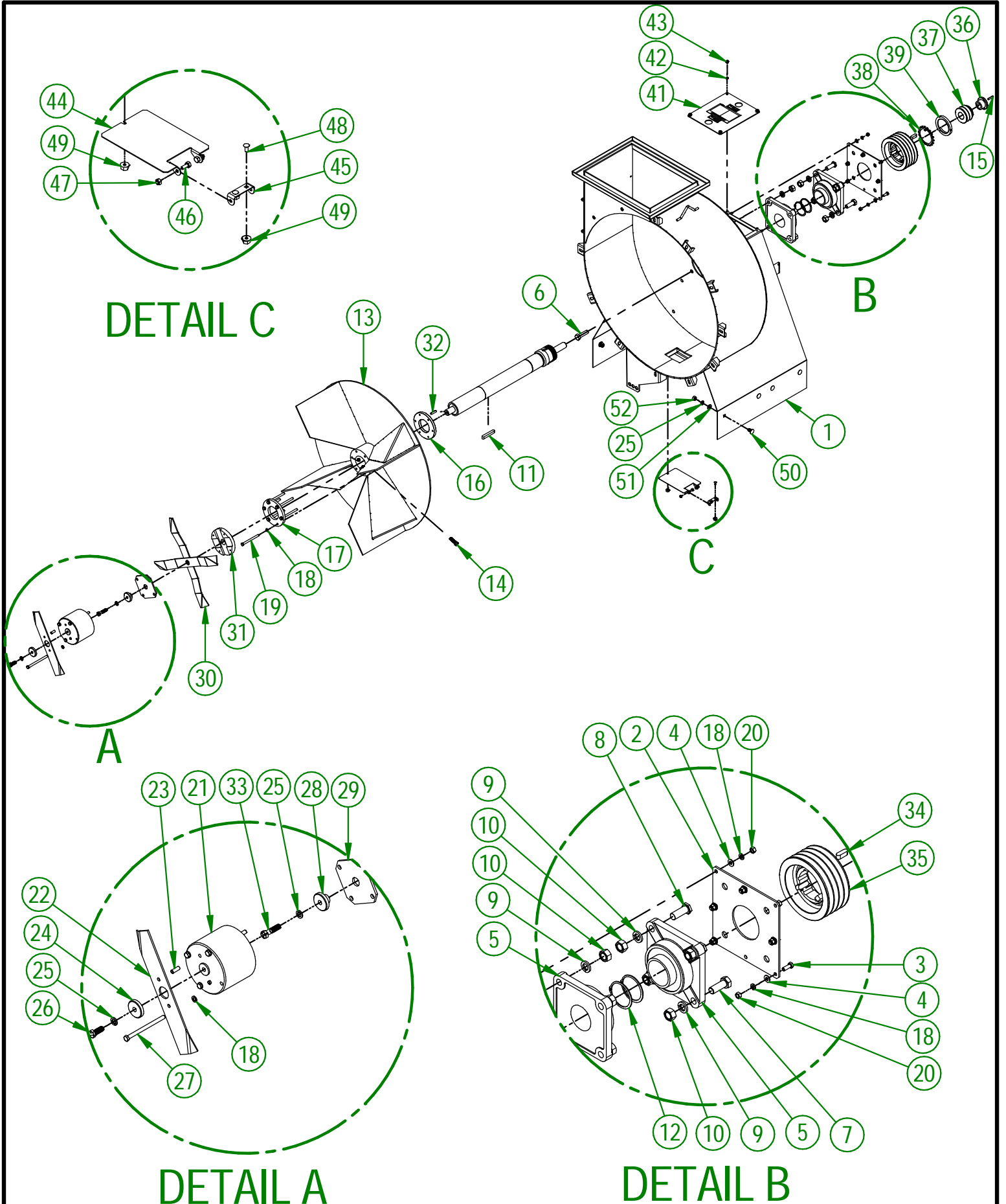

DETAIL C

B

A

C

DETAIL A

DETAIL B

USE THESE PIECES ONLY IF YOUR SERIAL NUMBER IS AFFECTED:

#41343 AND UNDER

AGRIMETAL	
BLOWER HOUSING ASSY.	
CREATION : 23/11/17	ASSEMBLY : 29-57-0016
REVISION : 08/02/22	AUTHOR : J.KABWE

29-57-0016

#	PART #	Qty	TITLE
1	29-57-0017	1	BLOWER HOUSING "STICKER INCLUDED"
2	28-04-0135	1	SUPPORT PLATE UCF215-48
3	NC01-17-0114	8	HEX. BOLT GR2 ZINC 3/8-16 X 1"
4	01-01-2485	8	FLAT WASHER 14 GA X 13/16"OD X 25/64" ID
5	NC14-75-0148	2	FLANGE ROLLER (3" DIA.)
6	NC01-17-0469	4	BOLT GR2 NC ZINC 3/4-10 X 2 1/2"
7	NC01-17-0467	2	HEX. BOLT GR2 ZINC 3/4-10 X 2"
8	28-30-9955	2	BOLT FOR UCF215-48 3/4-10 X 2"
9	NC02-32-0017	8	LOCK WASHER ZINC 3/4"
10	NC02-07-0023	8	HEX. NUT ZINC 3/4-10
11	NC01-65-0114	1	KEY 1/2" X 1/2" X 3 1/2"
12	NC01-64-0048	2	RETAINING RING 3" DIA.
13	29-50-0030	1	IMPELLER
14	NC01-29-0250	6	HEX. BOLT GR5 NF ZINC 1/2-20 X 1 3/4
15	NC01-65-0087	1	KEY 1/4 X 1/4 X 1 1/2"
16	28-04-0420	1	IMPELLER ANCHORAGE DISC (BACK)
17	28-04-0425	1	IMPELLER ANCHORAGE DISC. (FRONT)
18	NC02-32-0012	18	LOCK WASHER ZINC 3/8"
19	NC01-17-0128	6	HEX. BOLT GR2 ZINC 3/8-16 X 4 1/2"
20	NC02-07-0018	8	HEX. NUT ZINC 3/8-16
21	28-21-0025	1	BLADE HOLDER 6" DIA. X 4.750" LENGTH
22	NC13-22-0020	1	MOWER BLADE 14 9/16 " X 2 1/2 " LAR. X.170 "EP. X 1.375 DIA.
23	NC01-69-0491	2	SPRING TENSION PIN ZINC 3/8" X 1"
24	28-13-2815	1	BLADE RETAINING WASHER
25	NC02-32-0014	10	LOCK WASHER ZINC 1/2"
26	NC01-29-0248	1	HEX. BOLT GR5 NF ZINC 1/2-20 X 1 1/4
27	NC01-17-0132	4	HEX. BOLT GR2 NC 3/8-16 X 5 1/2" TL
28	28-13-2810	1	BLADE RETAINING FERRULE
29	28-04-0305	1	BLADE PLATE SUPPORT
30	28-46-0175	2	BLADE 20 1/8"
31	29-21-0005	1	BLADE SUPPORT
32	01-41-0915	1	KEY WAY 5/16" X 5/16" X 1 1/2"
33	NC01-29-0251	1	HEX. BOLT GR5 NF ZINC 1/2-20 X 2"
34	28-41-0915	3	AQUARE KEY 1/2" X 1/2" X 1 1/2"
35	28-39-0360	1	PULLEY 4B70 SK X 3.358" DIA. KW 1/2"
36	NC14-62-0016	1	QD BUSHING SH 1 1/4"
37	NC14-62-0197	1	PULLEY QD 2V 1/2-5/8 X 3.75 DE X SH 2B34
38	NC02-26-0517	1	STEEL NOTCHED WASHER MBI7
39	NC02-14-0517	1	NOTCHED NUTS KMI7
40	28-04-0180	1	SPRING SUPPORT
41	28-57-0091	1	COVER " STICKER INCLUDED"
42	NC02-32-0011	4	LOCK WASHER ZINC 5/16"
43	NC02-07-0017	4	HEX. NUT 5/16-18
44	38-01-2470	1	RIGHT AND LEFT DOOR
45	38-01-3020	1	HINGE
46	NC01-17-0003	2	HEX. BOLT GR2 ZINC 1/4-20 X 5/8"

29-57-0016

#	PART #	Qty	TITLE
47	NC01-96-0009	2	NYLON-INSERT LOCKNUT ZINC 1/4-20
48	NC01-04-0001	2	CARR. BOLT GR2 ZINC 1/4-20 X 1/2"
49	NC02-14-0017	3	FLANGED NUT GR. B 1/4-20
50	NC01-04-0233	8	CARR. BOLT GR2 ZINC 1/2-13 X 1"
51	NC02-25-0011	8	WASHER SAE ZINC 17/32 ID
52	NC02-07-0020	8	HEX. NUT ZINC 1/2-13

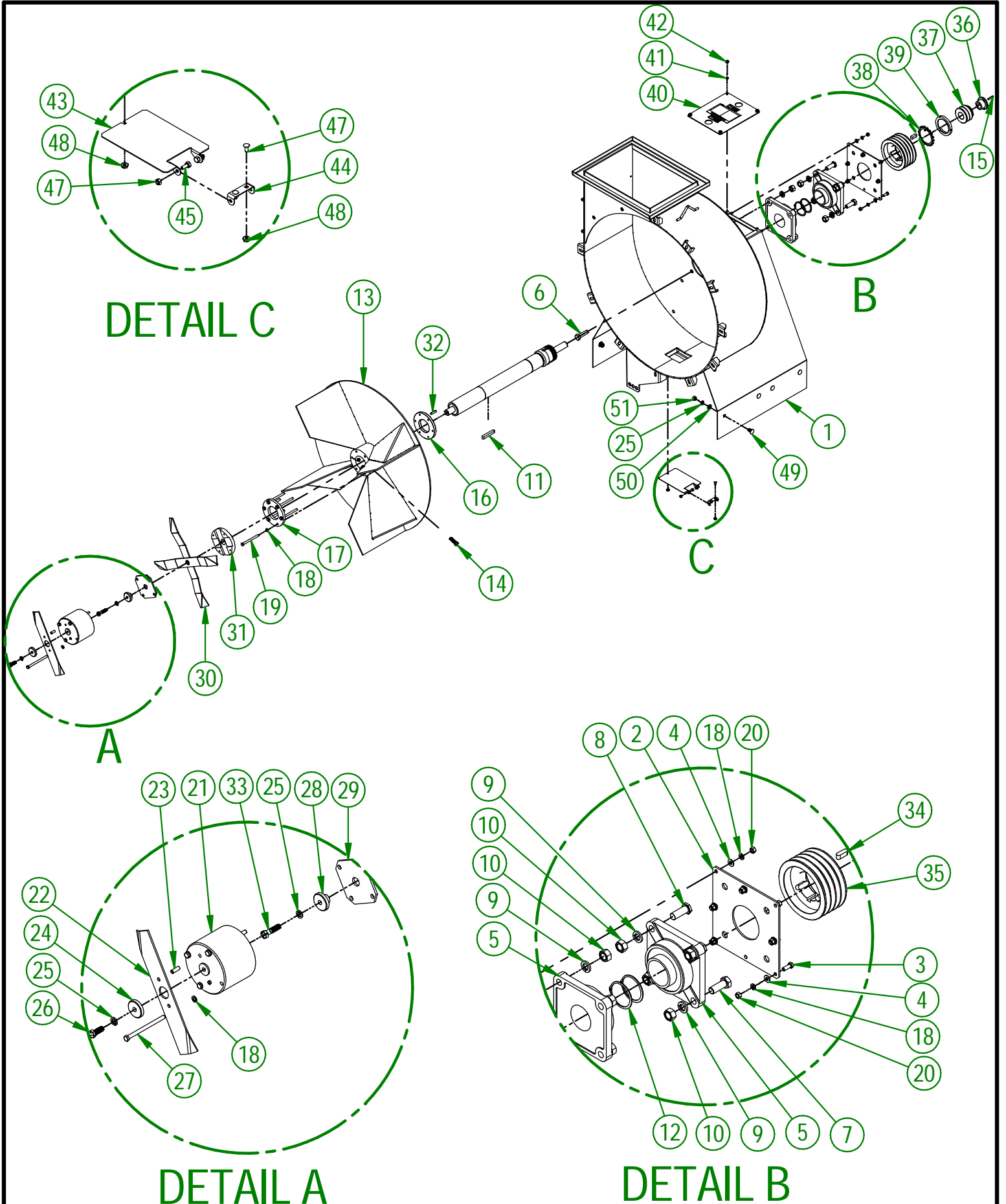

DETAIL C

B

A

DETAIL A

DETAIL B

USE THESE PIECES ONLY IF YOUR SERIAL NUMBER IS AFFECTED:

BETWEEN #41344 ET # 43304

AGRIMETAL	
BLOWER HOUSING ASSY.	
CREATION : 02/11/21	ASSEMBLY : 29-57-0018
REVISION : 30/05/24	AUTHOR : J.KABWE

29-57-0018

#	PART #	Qty	TITLE
1	29-57-0017	1	BLOWER HOUSING "STICKER INCLUDED"
2	28-04-0135	1	SUPPORT PLATE UCF215-48
3	NC01-17-0114	8	HEX. BOLT GR2 ZINC 3/8-16 X 1"
4	01-01-2485	8	FLAT WASHER 14 GA X 13/16"OD X 25/64" ID
5	NC14-75-0148	2	FLANGE ROLLER (3" DIA.)
6	NC01-17-0469	4	BOLT GR2 NC ZINC 3/4-10 X 2 1/2"
7	NC01-17-0467	2	HEX. BOLT GR2 ZINC 3/4-10 X 2"
8	28-30-9955	2	BOLT FOR UCF215-48 3/4-10 X 2"
9	NC02-32-0017	8	LOCK WASHER ZINC 3/4"
10	NC02-07-0023	8	HEX. NUT ZINC 3/4-10
11	NC01-65-0114	1	KEY 1/2" X 1/2" X 3 1/2"
12	NC01-64-0048	2	RETAINING RING 3" DIA.
13	29-50-0030	1	IMPELLER
14	NC01-29-0250	6	HEX. BOLT GR5 NF ZINC 1/2-20 X 1 3/4
15	NC01-65-0087	1	KEY 1/4 X 1/4 X 1 1/2"
16	28-04-0420	1	IMPELLER ANCHORAGE DISC (BACK)
17	28-04-0425	1	IMPELLER ANCHORAGE DISC. (FRONT)
18	NC02-32-0012	18	LOCK WASHER ZINC 3/8"
19	NC01-17-0128	6	HEX. BOLT GR2 ZINC 3/8-16 X 4 1/2"
20	NC02-07-0018	8	HEX. NUT ZINC 3/8-16
21	28-21-0025	1	BLADE HOLDER 6" DIA. X 4.750" LENGTH
22	NC13-22-0020	1	MOWER BLADE 14 9/16 " X 2 1/2 " LAR. X.170`EP. X 1.375 DIA.
23	NC01-69-0491	2	SPRING TENSION PIN ZINC 3/8" X 1"
24	28-13-2815	1	BLADE RETAINING WASHER
25	NC02-32-0014	10	LOCK WASHER ZINC 1/2"
26	NC01-29-0248	1	HEX. BOLT GR5 NF ZINC 1/2-20 X 1 1/4
27	NC01-17-0132	4	HEX. BOLT GR2 NC 3/8-16 X 5 1/2" TL
28	28-13-2810	1	BLADE RETAINING FERRULE
29	28-04-0305	1	BLADE PLATE SUPPORT
30	28-46-0175	2	BLADE 20 1/8"
31	29-21-0005	1	BLADE SUPPORT
32	01-41-0915	1	KEY WAY 5/16" X 5/16" X 1 1/2"
33	NC01-29-0251	1	HEX. BOLT GR5 NF ZINC 1/2-20 X 2"
34	28-41-0915	3	AQUARE KEY 1/2" X 1/2" X 1 1/2"
35	29-43-0000	1	6.6 PULLEY
36	NC14-62-0016	1	QD BUSHING SH 1 1/4"
37	NC14-62-0197	1	PULLEY QD 2V 1/2-5/8 X 3.75 DE X SH 2B34
38	NC02-26-0517	1	STEEL NOTCHED WASHER MBI7
39	NC02-14-0517	1	NOTCHED NUTS KMI7
40	28-57-0091	1	COVER " STICKER INCLUDED"
41	NC02-32-0011	4	LOCK WASHER ZINC 5/16"
42	NC02-07-0017	4	HEX. NUT 5/16-18
43	38-01-2470	1	RIGHT AND LEFT DOOR
44	38-01-3020	1	HINGE
45	NC01-17-0003	2	HEX. BOLT GR2 ZINC 1/4-20 X 5/8"
46	NC01-96-0009	2	NYLON-INSERT LOCKNUT ZINC 1/4-20

29-57-0018

#	PART #	Qty	TITLE
47	NC01-04-0001	2	CARR. BOLT GR2 ZINC 1/4-20 X 1/2"
48	NC02-14-0017	3	FLANGED NUT GR. B 1/4-20
49	NC01-04-0233	8	CARR. BOLT GR2 ZINC 1/2-13 X 1"
50	NC02-25-0011	8	WASHER SAE ZINC 17/32 ID
51	NC02-07-0020	8	HEX. NUT ZINC 1/2-13

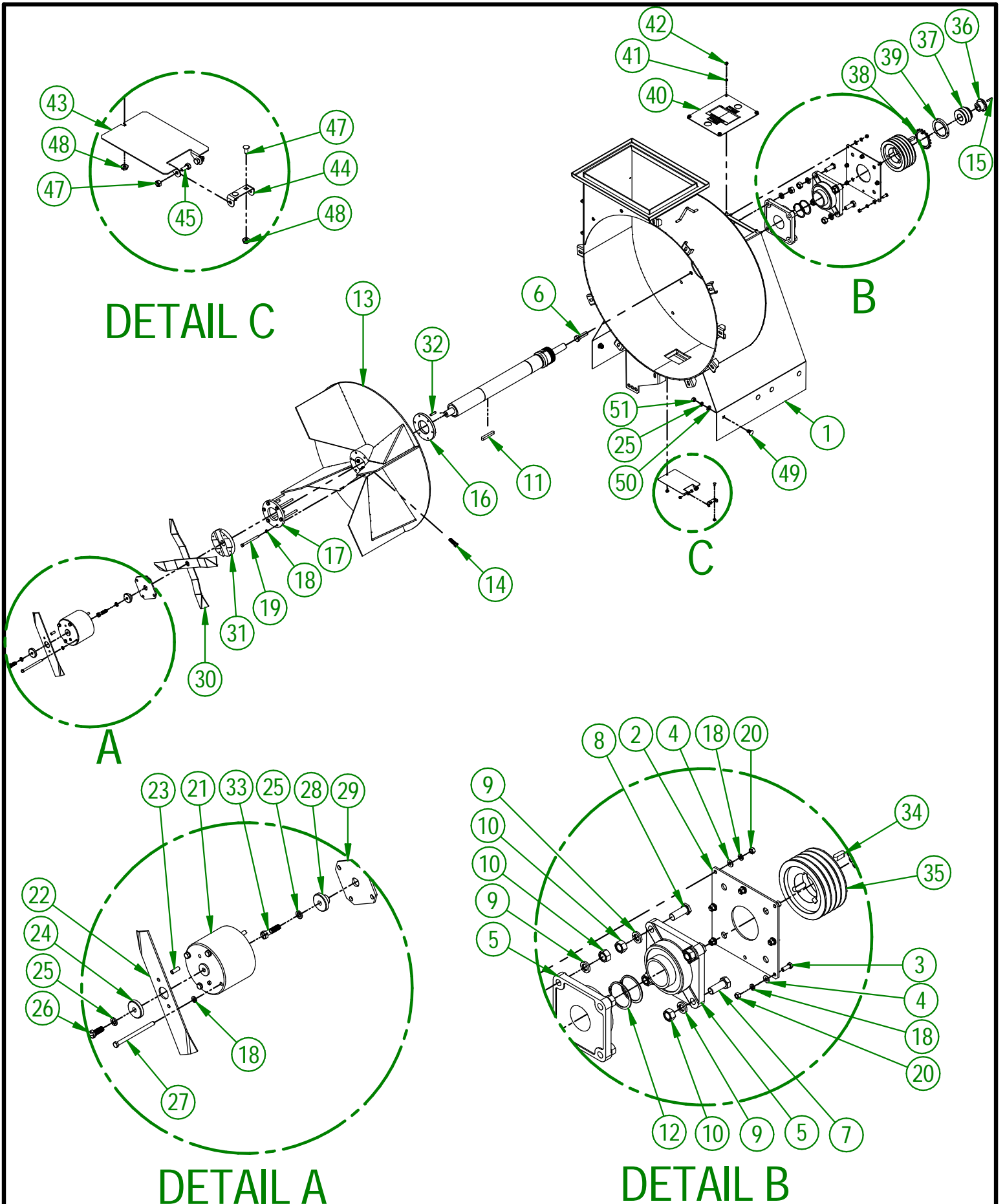

DETAIL C

B

A

C

DETAIL A

DETAIL B

USE THESE PIECES ONLY IF YOUR SERIAL NUMBER IS AFFECTED:

BETWEEN # 43816 & #48394

AGRIMETAL	
BLOWER HOUSING ASSY.	
CREATION : 10/03/23	ASSEMBLY : 29-57-0019
REVISION : 01/12/25	AUTHOR : J.KABWE

29-57-0019

#	PART #	Qty	TITLE
1	29-57-0017	1	BLOWER HOUSING "STICKER INCLUDED"
2	28-04-0135	1	SUPPORT PLATE UCF215-48
3	NC01-17-0114	8	HEX. BOLT GR2 ZINC 3/8-16 X 1"
4	01-01-2485	8	FLAT WASHER 14 GA X 13/16"OD X 25/64" ID
5	NC14-75-0148	2	FLANGE ROLLER (3" DIA.)
6	NC01-17-0469	4	BOLT GR2 NC ZINC 3/4-10 X 2 1/2"
7	NC01-17-0467	2	HEX. BOLT GR2 ZINC 3/4-10 X 2"
8	28-30-9955	2	BOLT FOR UCF215-48 3/4-10 X 2"
9	NC02-32-0017	8	LOCK WASHER ZINC 3/4"
10	NC02-07-0023	8	HEX. NUT ZINC 3/4-10
11	NC01-65-0114	1	KEY 1/2" X 1/2" X 3 1/2"
12	NC01-64-0048	2	RETAINING RING 3" DIA.
13	29-50-0030	1	IMPELLER
14	NC01-29-0250	6	HEX. BOLT GR5 NF ZINC 1/2-20 X 1 3/4
15	NC01-65-0087	1	KEY 1/4 X 1/4 X 1 1/2"
16	28-04-0420	1	IMPELLER ANCHORAGE DISC (BACK)
17	28-04-0425	1	IMPELLER ANCHORAGE DISC. (FRONT)
18	NC02-32-0012	18	LOCK WASHER ZINC 3/8"
19	NC01-17-0128	6	HEX. BOLT GR2 ZINC 3/8-16 X 4 1/2"
20	NC02-07-0018	8	HEX. NUT ZINC 3/8-16
21	28-21-0025	1	BLADE HOLDER 6" DIA. X 4.750" LENGTH
22	NC13-22-0020	1	MOWER BLADE 14 9/16 " X 2 1/2 " LAR. X.170`EP. X 1.375 DIA.
23	NC01-69-0491	2	SPRING TENSION PIN ZINC 3/8" X 1"
24	28-13-2815	1	BLADE RETAINING WASHER
25	NC02-32-0014	10	LOCK WASHER ZINC 1/2"
26	NC01-29-0248	1	HEX. BOLT GR5 NF ZINC 1/2-20 X 1 1/4
27	NC01-17-0132	4	HEX. BOLT GR2 NC 3/8-16 X 5 1/2" TL
28	28-13-2810	1	BLADE RETAINING FERRULE
29	28-04-0305	1	BLADE PLATE SUPPORT
30	28-46-0175	2	BLADE 20 1/8"
31	29-21-0005	1	BLADE SUPPORT
32	01-41-0915	1	KEY WAY 5/16" X 5/16" X 1 1/2"
33	NC01-29-0251	1	HEX. BOLT GR5 NF ZINC 1/2-20 X 2"
34	28-41-0915	3	AQUARE KEY 1/2" X 1/2" X 1 1/2"
35	29-39-0000	1	6.6 PULLEY
36	NC14-62-0016	1	QD BUSHING SH 1 1/4"
37	NC14-62-0197	1	PULLEY QD 2V 1/2-5/8 X 3.75 DE X SH 2B34
38	NC02-26-0517	1	STEEL NOTCHED WASHER MBI7
39	NC02-14-0517	1	NOTCHED NUTS KMI7
40	28-57-0091	1	COVER " STICKER INCLUDED"
41	NC02-32-0011	4	LOCK WASHER ZINC 5/16"
42	NC02-07-0017	4	HEX. NUT 5/16-18
43	38-01-2470	1	RIGHT AND LEFT DOOR
44	38-01-3020	1	HINGE
45	NC01-17-0003	2	HEX. BOLT GR2 ZINC 1/4-20 X 5/8"
46	NC01-96-0009	2	NYLON-INSERT LOCKNUT ZINC 1/4-20

29-57-0019

#	PART #	Qty	TITLE
47	NC01-04-0001	2	CARR. BOLT GR2 ZINC 1/4-20 X 1/2"
48	NC02-14-0017	3	FLANGED NUT GR. B 1/4-20
49	NC01-04-0233	8	CARR. BOLT GR2 ZINC 1/2-13 X 1"
50	NC02-25-0011	8	WASHER SAE ZINC 17/32 ID
51	NC02-07-0020	8	HEX. NUT ZINC 1/2-13

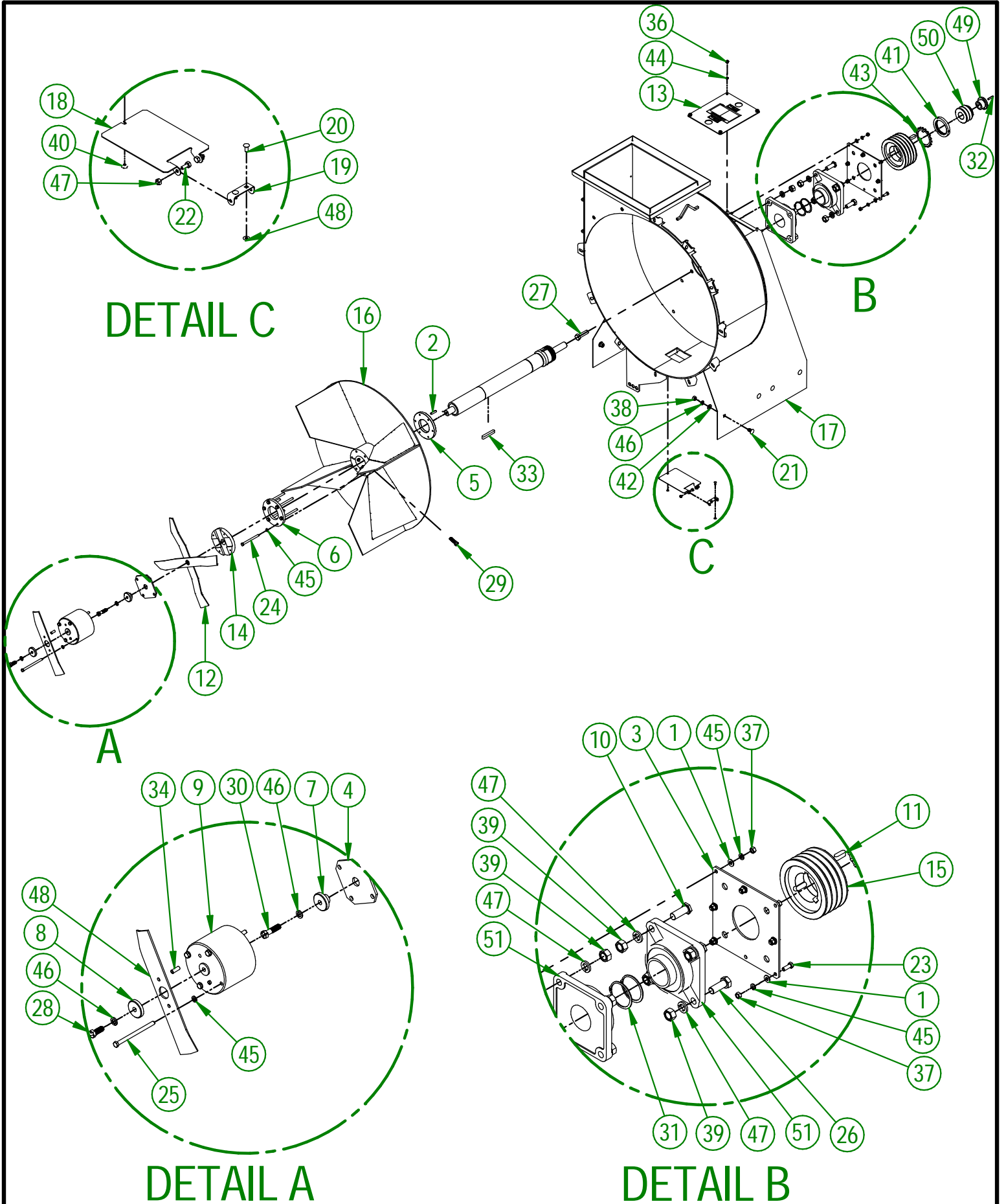

DETAIL C

B

A

C

DETAIL A

DETAIL B

USE THESE PIECES ONLY IF YOUR SERIAL NUMBER IS AFFECTED:

48394 & ABOVE

AGRIMETAL	
BLOWER HOUSING ASSY.	
CREATION : 01/12/25	ASSEMBLY : 29-57-0210
REVISION : 02/12/25	AUTHOR : J.KABWE

29-57-0210

#	PART #	Qty	TITLE
1	01-01-2485	8	FLAT WASHER 14 GA X 13/16"OD X 25/64" ID
2	01-41-0915	1	KEY WAY 5/16" X 5/16" X 1 1/2"
3	28-04-0135	1	SUPPORT PLATE UCF215-48
4	28-04-0305	1	BLADE PLATE SUPPORT
5	28-04-0420	1	IMPELLER ANCHORAGE DISC (BACK)
6	28-04-0425	1	IMPELLER ANCHORAGE DISC. (FRONT)
7	28-13-2810	1	BLADE RETAINING FERRULE
8	28-13-2815	1	BLADE RETAINING WASHER
9	28-21-0025	1	BLADE HOLDER 6" DIA. X 4.750" LENGTH
10	28-30-9955	2	BOLT FOR UCF215-48 3/4-10 X 2"
11	28-41-0915	3	AQUARE KEY 1/2" X 1/2" X 1 1/2"
12	28-46-0175	2	BLADE 20 1/8"
13	28-57-0091	1	COVER " STICKER INCLUDED"
14	29-21-0005	1	BLADE SUPPORT
15	29-39-0000	1	6.6 PULLEY
16	29-50-0031	1	IMPELLER
17	29-57-0215	1	BLOWER HOUSING "STICKER INCLUDED"
18	38-01-2470	1	RIGHT AND LEFT DOOR
19	38-01-3020	1	HINGE
20	NC01-04-0001	2	CARR. BOLT GR2 ZINC 1/4-20 X 1/2"
21	NC01-04-0233	8	CARR. BOLT GR2 ZINC 1/2-13 X 1"
22	NC01-17-0003	2	HEX. BOLT GR2 ZINC 1/4-20 X 5/8"
23	NC01-17-0114	8	HEX. BOLT GR2 ZINC 3/8-16 X 1"
24	NC01-17-0128	6	HEX. BOLT GR2 ZINC 3/8-16 X 4 1/2"
25	NC01-17-0132	4	HEX. BOLT GR2 NC 3/8-16 X 5 1/2" TL
26	NC01-17-0467	2	HEX. BOLT GR2 ZINC 3/4-10 X 2"
27	NC01-17-0469	4	BOLT GR2 NC ZINC 3/4-10 X 2 1/2"
28	NC01-29-0248	1	HEX. BOLT GR5 NF ZINC 1/2-20 X 1 1/4
29	NC01-29-0250	6	HEX. BOLT GR5 NF ZINC 1/2-20 X 1 3/4
30	NC01-29-0251	1	HEX. BOLT GR5 NF ZINC 1/2-20 X 2"
31	NC01-64-0048	2	RETAINING RING 3" DIA.
32	NC01-65-0087	1	KEY 1/4 X 1/4 X 1 1/2"
33	NC01-65-0114	1	KEY 1/2" X 1/2" X 3 1/2"
34	NC01-69-0491	2	SPRING TENSION PIN ZINC 3/8" X 1"
35	NC01-96-0009	2	NYLON-INSERT LOCKNUT ZINC 1/4-20
36	NC02-07-0017	4	HEX. NUT 5/16-18
37	NC02-07-0018	8	HEX. NUT ZINC 3/8-16
38	NC02-07-0020	8	HEX. NUT ZINC 1/2-13
39	NC02-07-0023	8	HEX. NUT ZINC 3/4-10
40	NC02-14-0017	3	FLANGED NUT GR. B 1/4-20
41	NC02-14-0517	1	NOTCHED NUTS KMI7
42	NC02-25-0011	8	WASHER SAE ZINC 17/32 ID
43	NC02-26-0517	1	STEEL NOTCHED WASHER MBI7
44	NC02-32-0011	4	LOCK WASHER ZINC 5/16"
45	NC02-32-0012	18	LOCK WASHER ZINC 3/8"
46	NC02-32-0014	10	LOCK WASHER ZINC 1/2"

29-57-0210

#	PART #	Qty	TITLE
47	NC02-32-0017	8	LOCK WASHER ZINC 3/4"
48	NC13-22-0020	1	MOWER BLADE 14 9/16 " X 2 1/2 " LAR. X.170`EP. X 1.375 DIA.
49	NC14-62-0016	1	QD BUSHING SH I 1/4"
50	NC14-62-0197	1	PULLEY QD 2V 1/2-5/8 X 3.75 DE X SH 2B34
51	NC14-75-0148	2	FLANGE ROLLER (3" DIA.)

#	PART #	Qty	TITLE
1	28-09-1500	1	IMPELLER SHAFT
2	28-20-0055	1	MULCHER SHAFT
3	28-55-0065	2	ROLLER (SER206-20)
4	NC01-64-0166	2	RETAINING RING 2 7/16"
5	NC01-64-0016	2	RETAINING RING 1 1/4"
6	NC13-80-0220	2	SEAL .312" X 1 1/4" X 2.445" OR 62 MM
7	NC02-44-0202	4	PRESSURE SCREW 6PANS NPTF 1/8-27

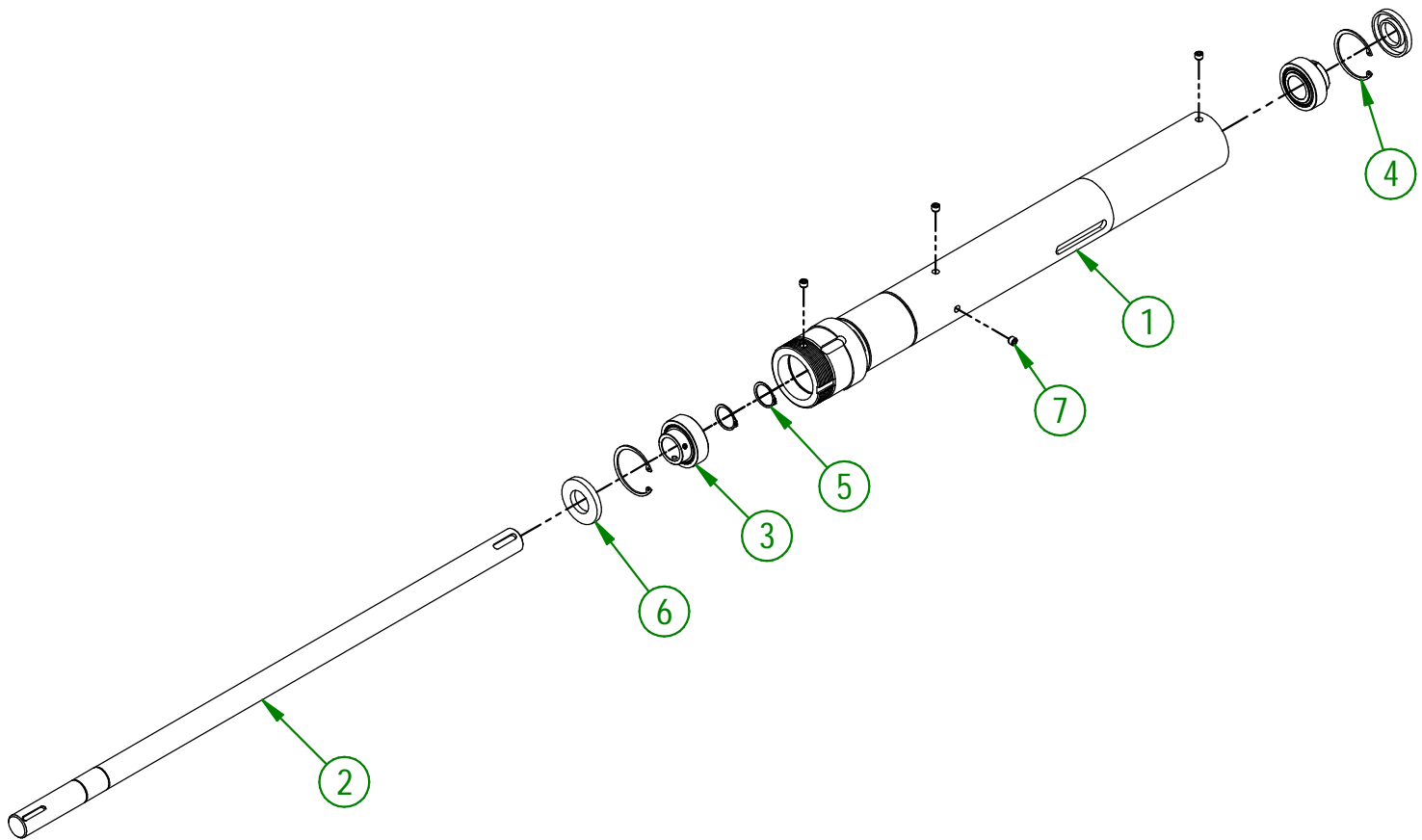

USE THESE PIECES ONLY IF YOUR SERIAL
NUMBER IS AFFECTED:

43304 AND UNDER

AGRIMETAL	
BLOWER SHAFT	
CREATION : 06/07/17	ASSEMBLY : 28-55-0380
REVISION : 30/05/24	AUTHOR : J.KABWE

#	PART #	Qty	TITLE
1	28-09-1501	1	IMPELLER SHAFT
2	28-20-0056	1	MULCHER SHAFT
3	28-55-0065	2	ROLLER (SER206-20)
4	NC01-64-0016	2	RETAINING RING 1 1/4"
5	NC01-64-0166	2	RETAINING RING 2 7/16"
6	NC02-44-0202	4	PRESSURE SCREW 6PANS NPTF 1/8-27
7	NC13-80-0220	2	SEAL .312" X 1 1/4" X 2.445" OR 62 MM

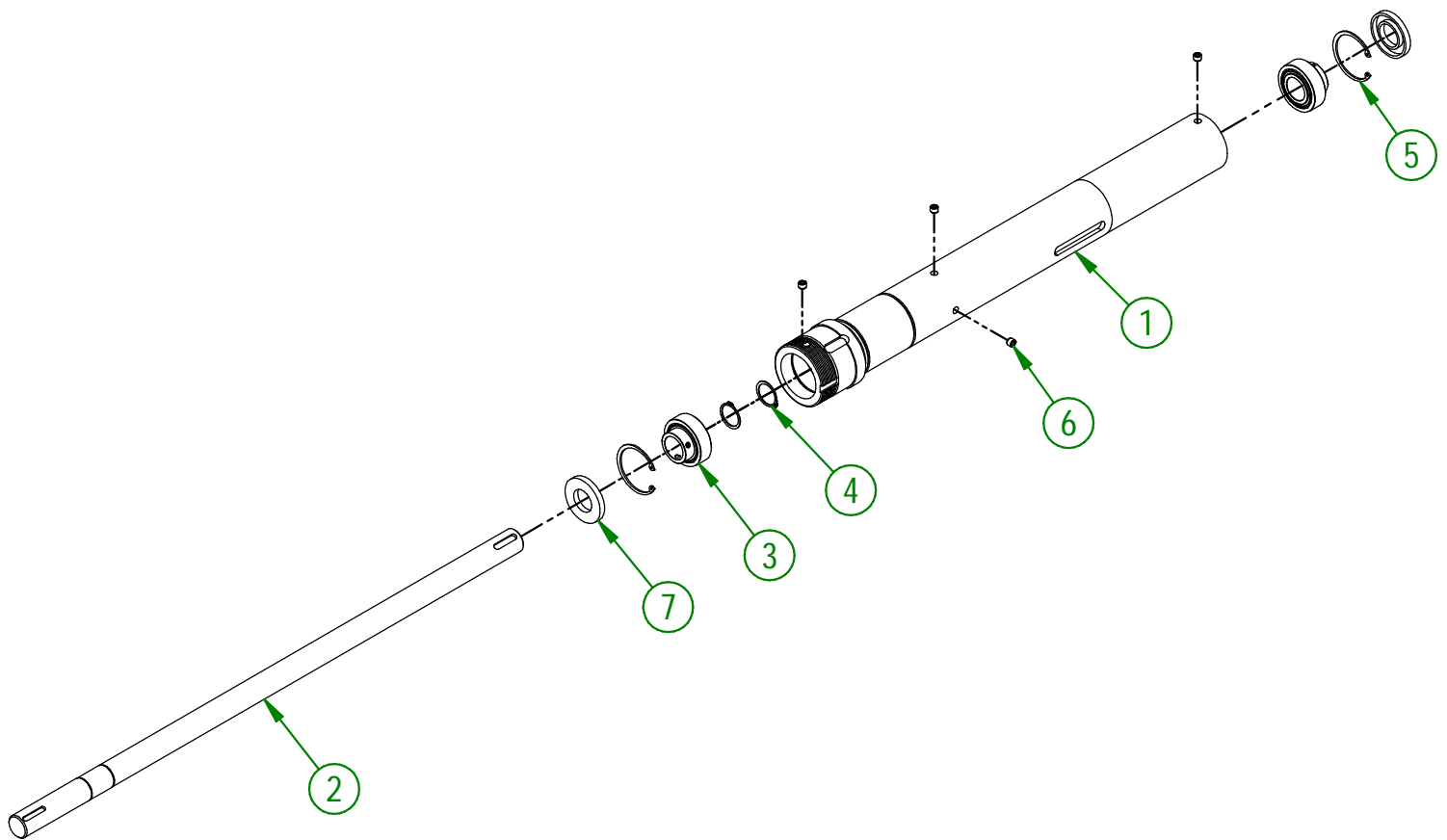

USE THESE PIECES ONLY IF YOUR SERIAL
NUMBER IS AFFECTED:

#43816 AND ABOVE

MACHINE: MULTI-VAC 1096-10120-772

AGRIMETAL
BLOWER SHAFT

CREATION : 30/05/24
REVISION : 30/05/24

ASSEMBLY : **28-55-0381**
AUTHOR : J.KABWE

#	PART #	Qty	TITLE
1	29-50-0090	1	BELT-TIGHTENER GUIDE
2	01-01-1660	4	WASHER SPACER
3	NC01-17-0257	2	HEX. BOLT GR2 ZINC 1/2-13 X 3 1/2"
4	NC02-32-0014	2	LOCK WASHER ZINC 1/2"
5	NC02-07-0020	2	HEX. NUT ZINC 1/2-13
6	28-50-0145	1	TIGHTENER STOPPER NUT
7	29-50-0100	1	BELT-TIGHTENER (B104)
8	12-44-0015	1	RED SPRING 1 1/2" OD 1" ID X 8 1/2"
9	NC02-22-0013	1	WASHER ZINC 5/8 ID X 1 1/2 OD
10	28-42-0155	2	SPRING GUIDE
11	28-42-0110	1	FLAT WASHER 1 1/4" DIA.
12	NC02-14-0304	1	HEX. NUT CHÂTEAU 5/8-11 NC ZINC
13	NC01-69-0423	2	SPRING PIN 3/16" X 1 1/4"

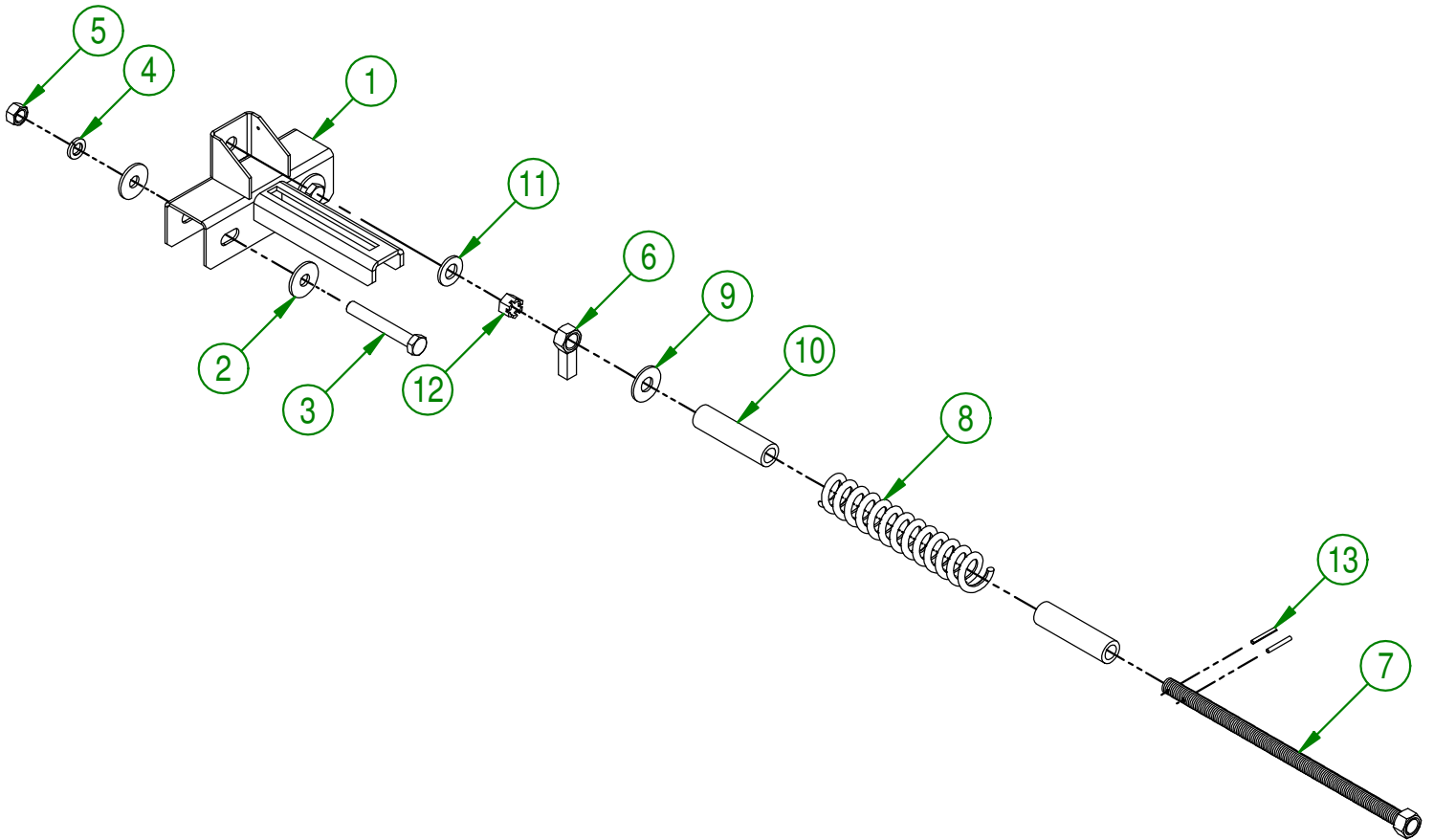
**AGRIMETAL****B 104 BELT TIGHTENER**

CREATION : 12/07/17
 REVISION : 25/01/18

ASSEMBLY : **29-57-0025**

AUTHOR : J.KABWE Page 32 de 72

#	PART #	Qty	TITLE
1	29-50-0020	1	FRONT GUARD
2	01-01-2485	12	FLAT WASHER
3	NC02-32-0012	12	LOCK WASHER ZINC 3/8"
4	NC01-17-0114	12	HEX. BOLT GR2 ZINC 3/8-16 X 1"
5	28-01-2500	1	GREASING ACCESS DOOR
6	23-01-2650	1	ACCESS DOOR IMPELLER HINGE
7	NC01-17-0003	2	HEX. BOLT GR2 ZINC 1/4-20 X 5/8"
8	NC01-96-0009	2	NYLON-INSERT LOCKNUT ZINC 1/4-20
9	NC01-04-0001	2	CARR. BOLT GR2 ZINC 1/4-20 X 1/2"
10	NC02-14-0017	3	FLANGED NUT GR. B 1/4-20

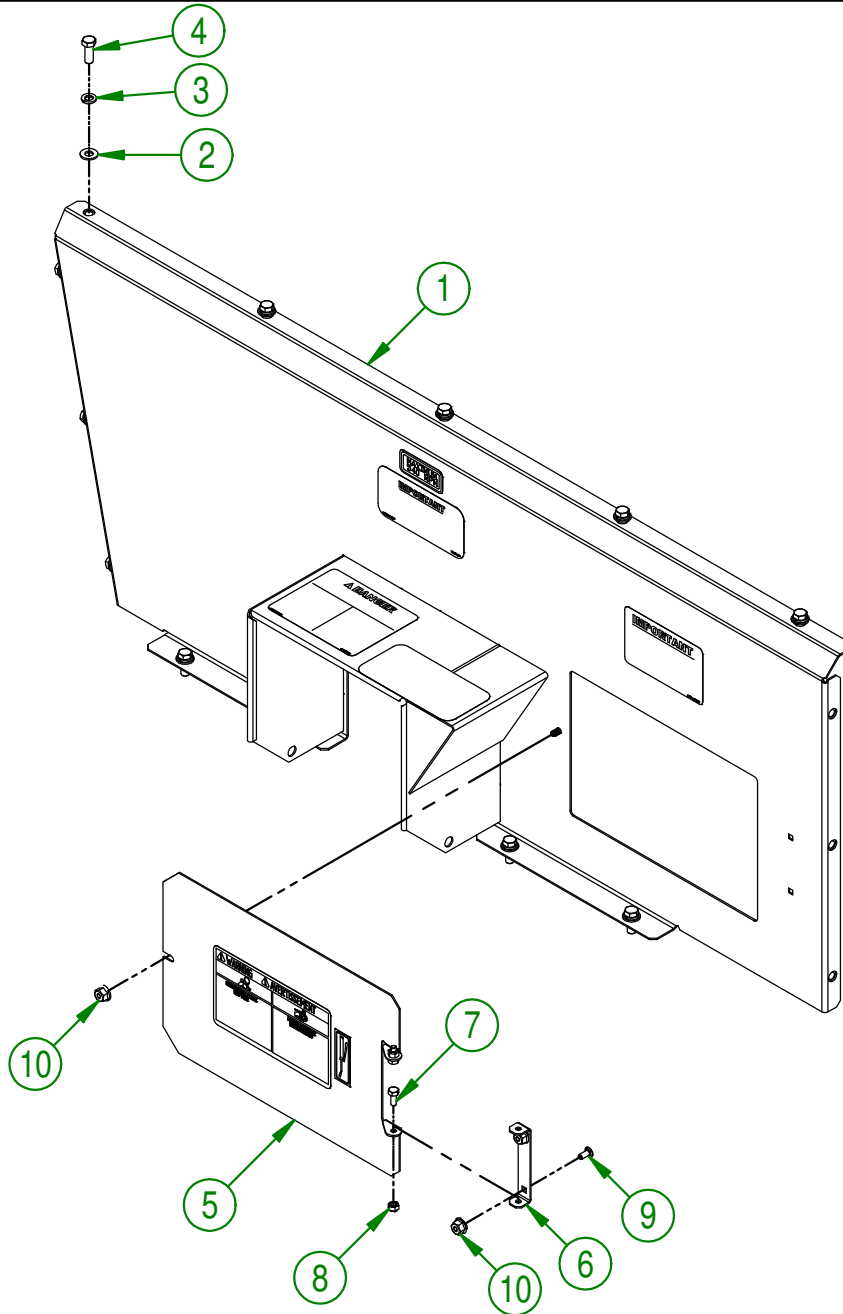

AGRIMETAL
PTO FRONT GUARD ASSY.

CREATION : 24/11/17
REVISION : 25/01/18

ASSEMBLY : **29-57-0051**

AUTHOR : J.KABWE Page 33 de 72

#	PART #	Qty	TITLE
1	28-50-0050	1	LEFT SIDE GUARD
2	01-01-2485	10	FLAT WASHER
3	NC02-32-0012	10	LOCK WASHER ZINC 3/8"
4	NC01-17-0114	10	HEX. BOLT GR2 ZINC 3/8-16 X 1"
5	28-01-2475	1	GREASING ACCESS DOOR
6	38-01-3020	1	HINGE
7	NC01-17-0003	2	HEX. BOLT GR2 ZINC 1/4-20 X 5/8"
8	NC01-96-0009	2	NYLON-INSERT LOCKNUT ZINC 1/4-20
9	NC01-04-0001	2	CARR. BOLT GR2 ZINC 1/4-20 X 1/2"
10	NC02-14-0017	3	FLANGED NUT GR. B 1/4-20

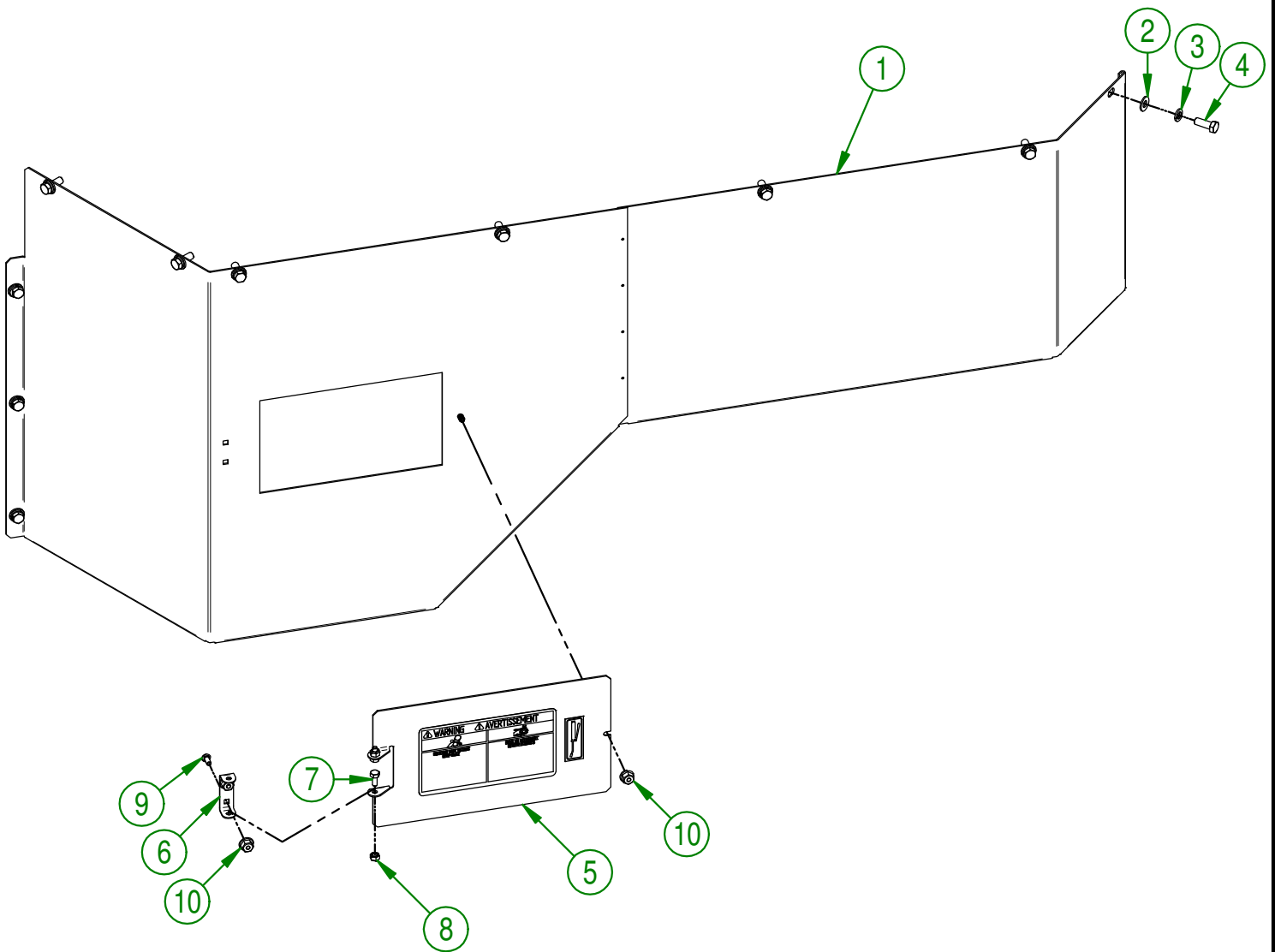

AGRIMETAL	
LEFT SIDE GUARD ASSY.	
CREATION : 24/11/17	ASSEMBLY : 28-57-0255
REVISION : 25/01/18	AUTHOR : J.KABWE Page 34 de 72

#	PART #	Qty	TITLE
1	29-50-0085	1	LEFT TRIANGLE GUARD
2	29-50-0086	1	RIGHT TRIANGLE GUARD
3	01-01-2485	2	FLAT WASHER
4	NC02-32-0012	2	LOCK WASHER ZINC 3/8"
5	NC01-17-0114	2	HEX. BOLT GR2 ZINC 3/8-16 X 1"

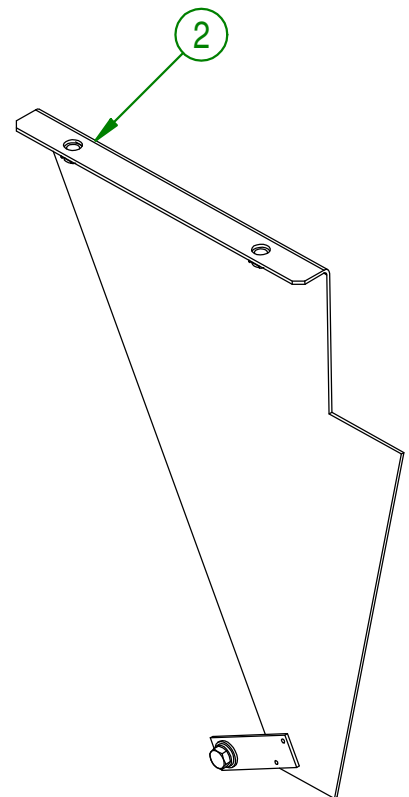
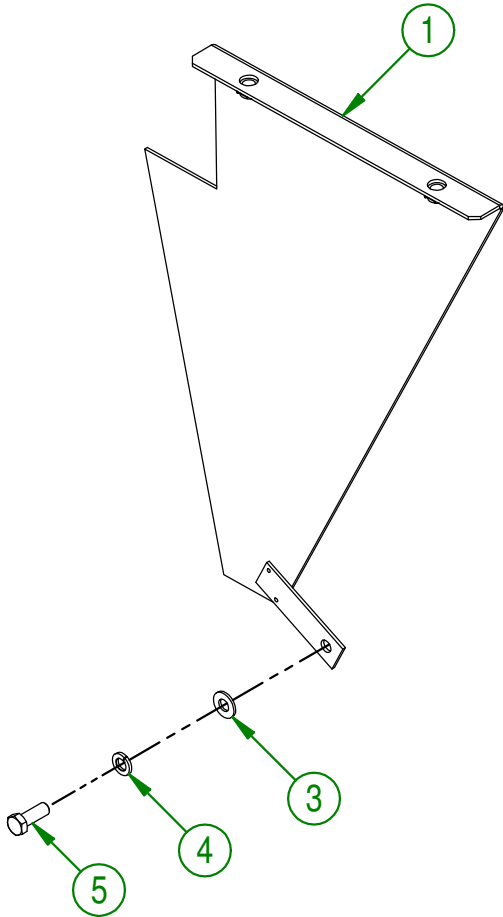

AGRIMETAL	
LEFT & RIGHT TRIANGLE GUARD	
CREATION : 13/07/17	ASSEMBLY : 29-57-0030
REVISION : 25/01/18	AUTHOR : J.KABWE Page 35 de 72

#	PART #	Qty	TITLE
1	29-01-0905	1	REMOVABLE STEP LEFT
2	01-01-2485	4	FLAT WASHER
3	NC02-32-0012	4	LOCK WASHER ZINC 3/8"
4	NC01-17-0114	4	HEX. BOLT GR2 ZINC 3/8-16 X 1"

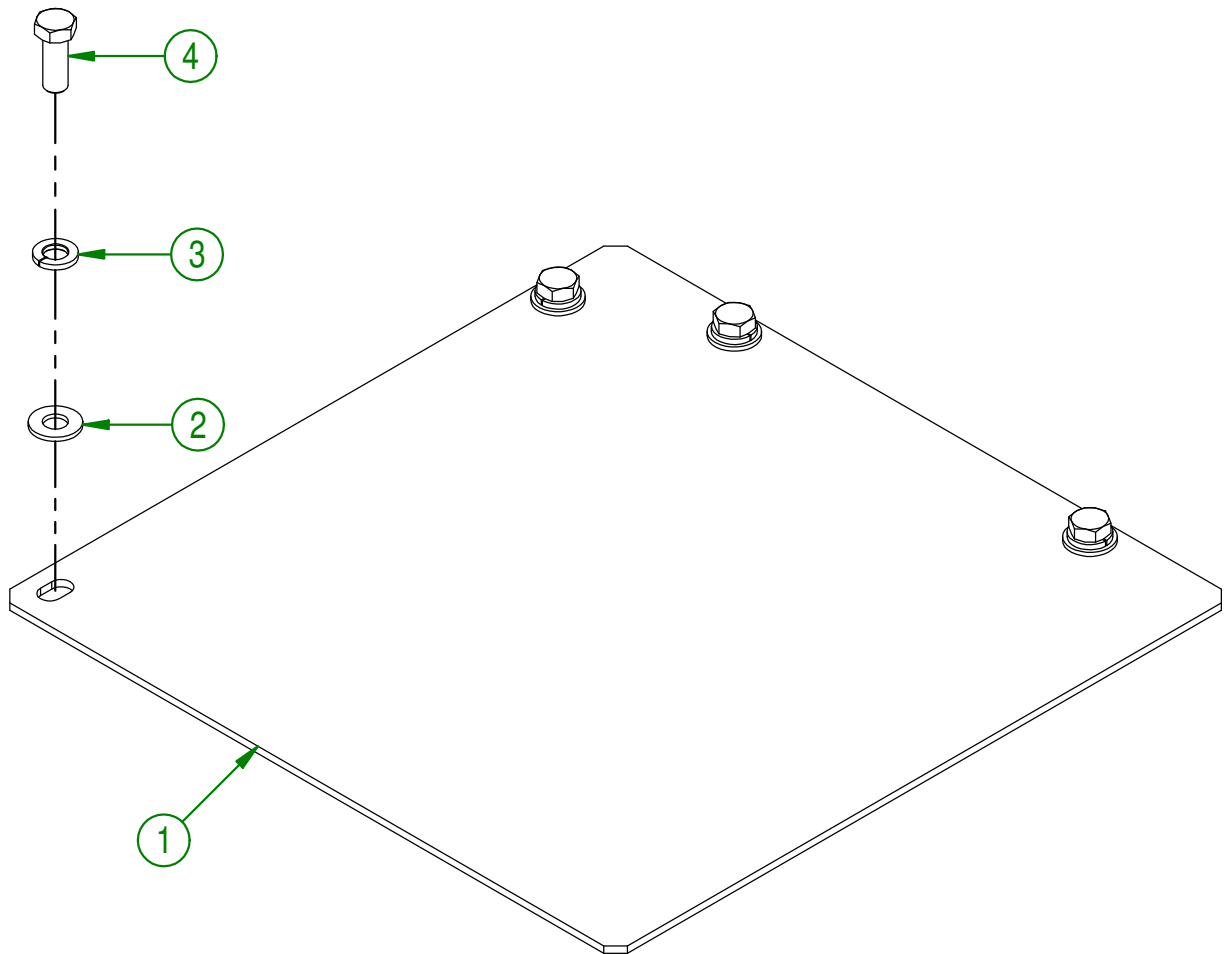

AGRIMETAL	
REMOVABLE STEP ASSY. (LEFT)	
CREATION : 13/07/17	ASSEMBLY : 29-57-0035
REVISION : 25/01/18	AUTHOR : J.KABWE Page 36 de 72

#	PART #	Qty	TITLE
1	29-01-0910	1	REMOVABLE STEP (RIGHT)
2	01-01-2485	4	FLAT WASHER
3	NC02-32-0012	4	LOCK WASHER ZINC 3/8"
4	NC01-17-0114	4	HEX. BOLT GR2 ZINC 3/8-16 X 1"

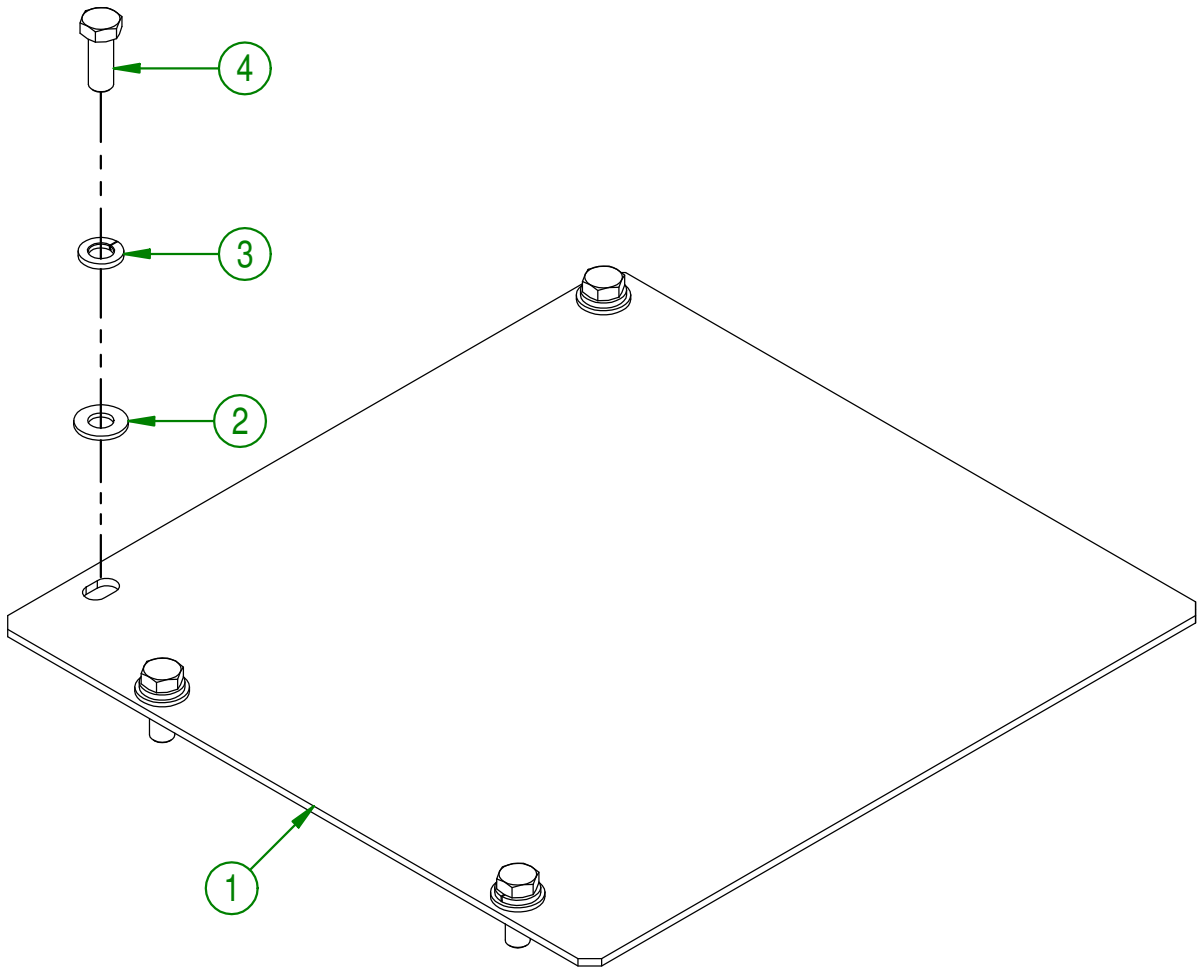

AGRIMETAL	
REMOVABLE STEP ASSY. (RIGHT)	
CREATION : 13/07/17	ASSEMBLY : 29-57-0040
REVISION : 25/01/18	AUTHOR : J.KABWE Page 37 de 72

28-57-0171

#	PART #	Qty	TITLE
1	28-50-0155	1	PULLEY ' S GUARD "4B70"
2	01-01-2485	4	FLAT WASHER
3	NC02-32-0012	4	LOCK WASHER ZINC 3/8"
4	NC01-17-0114	4	HEX. BOLT GR2 ZINC 3/8-16 X 1"

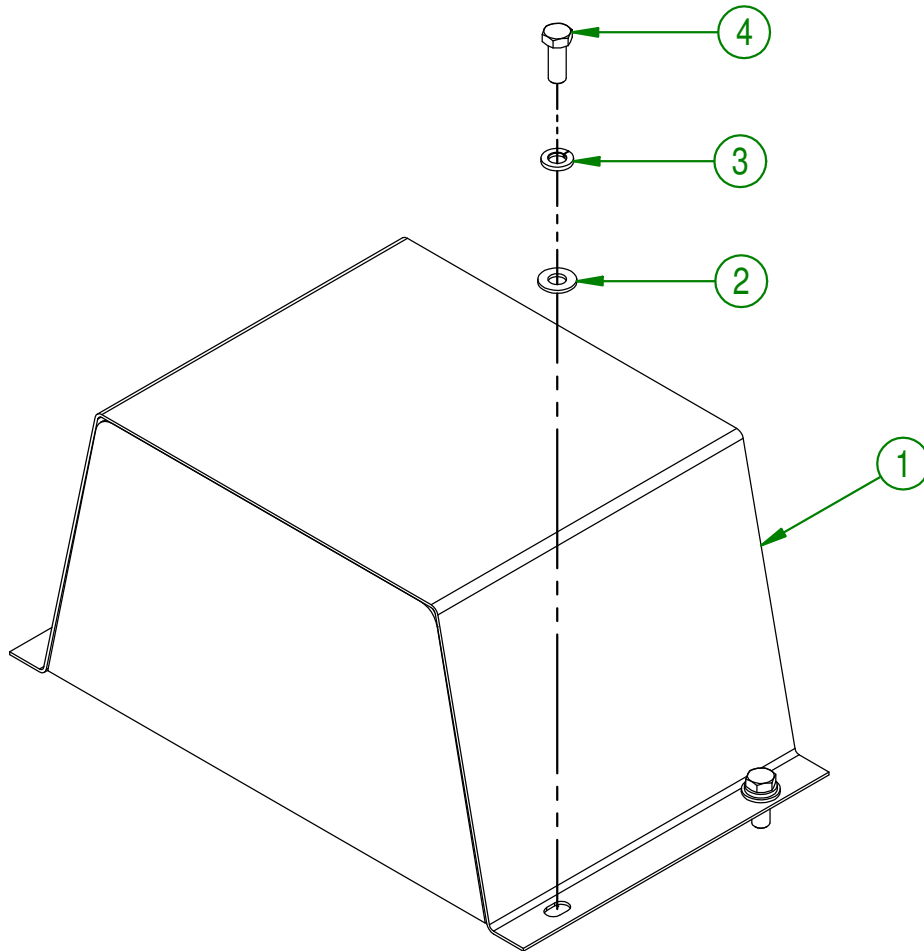

AGRIMETAL	
PULLEY ' S GUARD "4B70" ASSY.	
CREATION : 13/07/17	ASSEMBLY : 28-57-0171
REVISION : 25/01/18	AUTHOR : J.KABWE Page 38 de 72

#	PART #	Qty	TITLE
1	29-50-0115	1	SAFETY POST
2	NC01-17-0402	1	HEX. BOLT GR2 ZINC 5/8-11 X 3 1/2"
3	NC02-22-0013	1	WASHER ZINC 5/8 ID X 1 1/2 OD
4	NC01-96-0016	1	NYLON INSERT NUT 5/8-11
5	28-41-0010	1	CHAIN # 3 R560 (15 LINKS)
6	28-55-0205	1	LOCK PIN 3/8" DIA. X 2 3/8"GRIP ASSY.

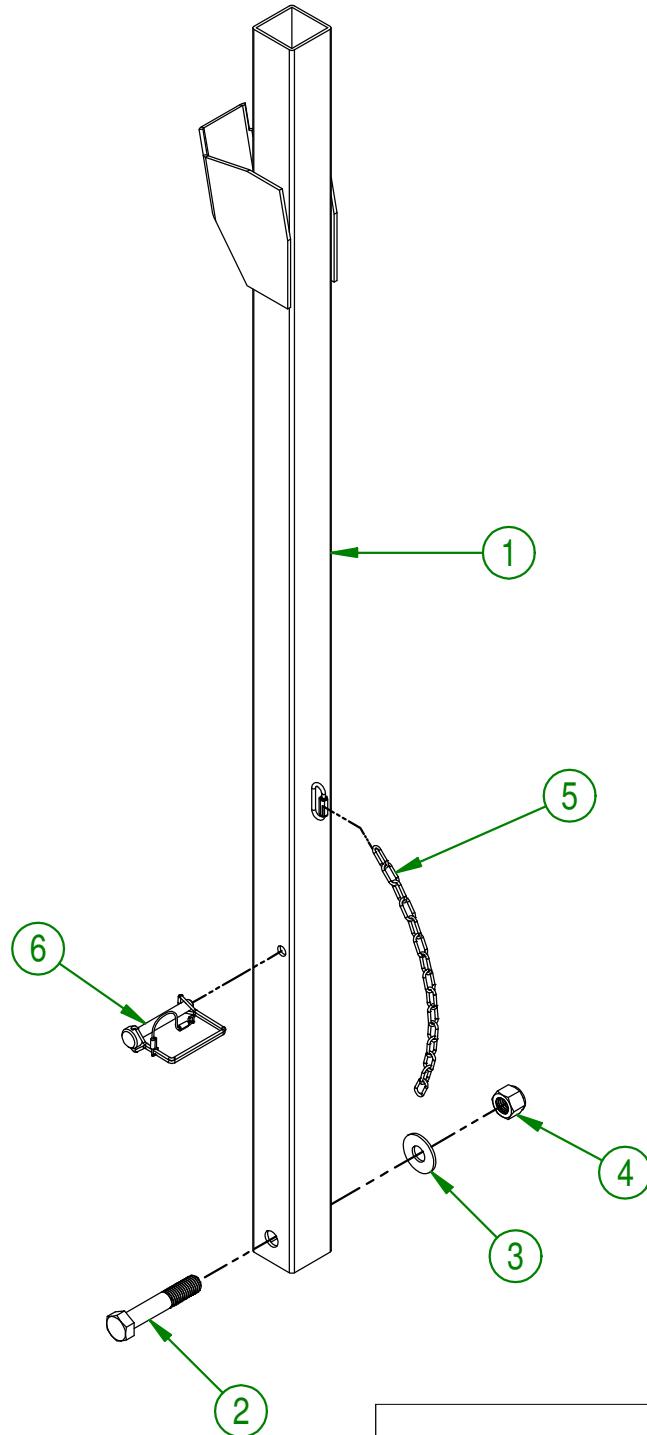

AGRIMETAL
BOX SAFETY POST ASSY.

CREATION : 13/07/17
 REVISION : 25/01/18

ASSEMBLY : **29-57-0060**

AUTHOR : J.KABWE | Page 39 de 72

#	PART #	Qty	TITLE
1	29-55-0025	1	OPT. 6' COMPLETE PICK-UP HEAD WITH RUBBER FINGER ROTARY BRU
2	28-50-0035	2	HYDRAULIC CYLINDER PIVOT
3	21-13-1000	2	PIN
4	28-13-1015	2	PICK-UP HEAD PIN
5	01-33-0035	4	FLAT WASHER 1 1/4" X 3/4"
6	NC01-63-0015	8	COTTER PIN Z 1/8" X 2 5/8"

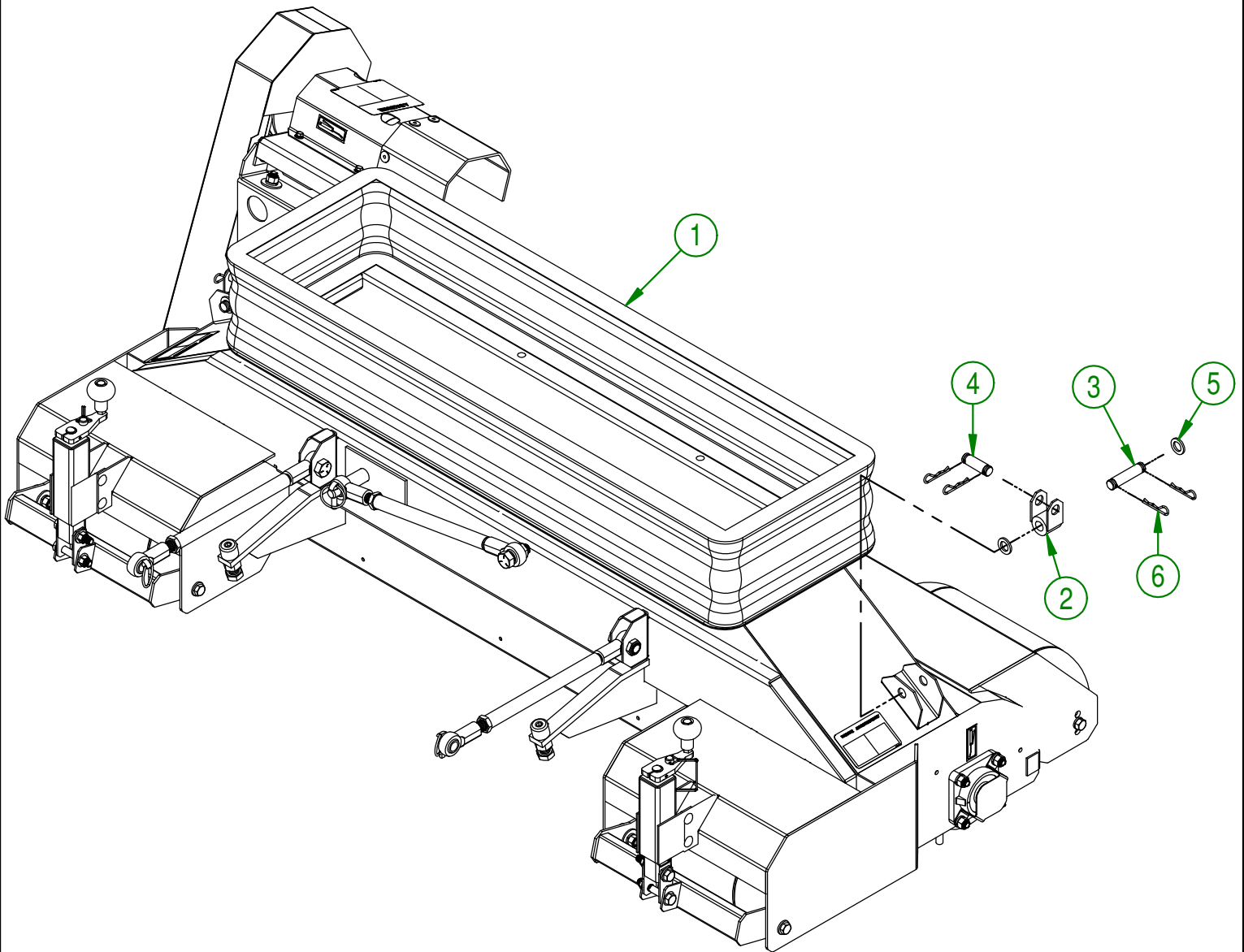
**AGRIMETAL****PICK-UP HEAD AND BRUSH GROUP.**

CREATION : 18/07/17
 REVISION : 25/01/18

ASSEMBLY : **29-57-0115**

AUTHOR : J.KABWE | Page 40 de 72

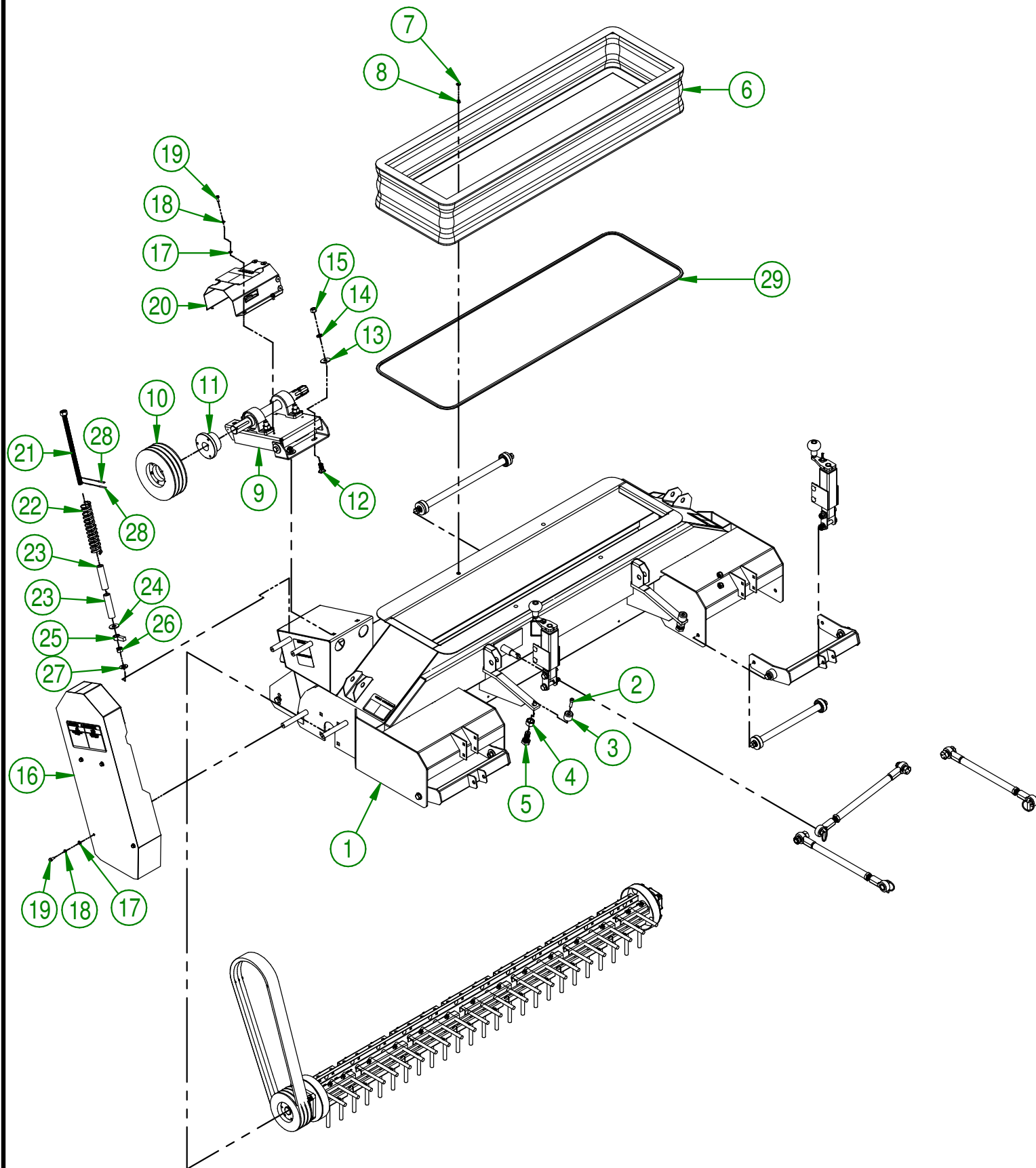

AGRIMETAL

OPT. 6' COMPLETE PICK-UP HEAD WITH RUBBER FINGER ROTARY BRU

CREATION : 18/07/17
 REVISION : 15/09/21

ASSEMBLY : **29-55-0025**
 AUTHOR : J.KABWE

#	PART #	Qty	TITLE
1	29-57-0010	1	PICK-UP HEAD "STICKER INCLUDED"
2	NC02-50-0101	2	ALLEN SET SCREWS 5/16-18 X 1 1/4"
3	28-13-1430	2	STABILIZING FERRULE
4	NC02-07-0023	2	HEX. NUT ZINC 3/4-10
5	28-30-9950	2	BOLT 3/4-10 1 3/4"
6	NC17-11-0013	1	EXPANDING BOOT 18 1/2"
7	NC02-22-0008	4	WASHER ZINC 5/16"
8	NC01-96-0009	4	NYLON-INSERT LOCKNUT ZINC 1/4-20
9	28-55-0360	1	BELT-TIGHTENER BASE MOUNT
10	NC14-62-0102	1	CAST IRON SHAVE PULLEY 3B80
11	NC14-62-0020	1	TAPERED QD BUSHING SK 1 3/8"
12	NC01-04-0234	2	CARR. BOLT GR2 ZINC 1/2-13 X 1 1/4
13	01-01-1660	2	WASHER SPACER
14	NC02-32-0014	2	LOCK WASHER ZINC 1/2"
15	NC02-07-0020	2	HEX. NUT ZINC 1/2-13
16	28-57-0030	1	BELT GUARD "STICKER INCLUDED"
17	NC02-25-0007	8	WASHER ZINC 0.281 = 9/32
18	NC02-32-0010	8	LOCK WASHER ZINC 1/4"
19	NC01-17-0003	8	HEX. BOLT GR2 ZINC 1/4-20 X 5/8"
20	28-55-0125	1	PILLOW BEARING GUARD" STICKER INCLUDED"
21	28-50-0225	1	BELT-TIGHTENER
22	12-44-0015	1	RED SPRING 1 1/2" OD 1" ID X 8 1/2"
23	28-42-0155	2	SPRING GUIDE
24	NC02-22-0013	1	WASHER ZINC 5/8 ID X 1 1/2 OD
25	28-50-0145	1	TIGHTENER STOPPER NUT
26	NC02-14-0304	1	HEX. NUT CHÂTEAU 5/8-11 NC ZINC
27	28-42-0110	1	FLAT WASHER 1 1/4" DIA.
28	NC01-69-0423	2	SPRING PIN 3/16" X 1 1/4"
29	29-46-3765	1	GASKET

AGRIMETAL

OPT. 6' COMPLETE PICK-UP HEAD WITH RUBBER FINGER ROTARY BRU

CREATION : 18/07/17
REVISION : 15/09/21

ASSEMBLY : **29-55-0025**
AUTHOR : J.KABWE

#	PART #	Qty	TITLE
1	29-55-0021	1	OPT.6' RUBBER FINGER ROTARY BRUSH
2	28-50-0305	2	BEARING GUARD AND REINFORCEMENT
3	NC14-75-0024	2	FLANGE BEARING 4 HOLES UCF207-20 1 1/4" DIA.
4	12-01-3051	1	REAR BEARING PROTECTOR
5	NC01-04-0236	8	CARR. BOLT GR2 NC ZINC 1/2-13 1 3/4"
6	NC02-32-0014	8	LOCK WASHER ZINC 1/2"
7	NC02-07-0020	8	HEX. NUT ZINC 1/2-13
8	NC14-62-0223	1	CAS IRON SHAVE PULLEY 3B60 SD
9	NC14-62-0005	1	QD BUSHING SD 1 1/4"
10	NC01-65-0087	1	KEY 1/4 X 1/4 X 1 1/2"
11	NC14-25-3376	1	V BELT 3RB-63 21/32

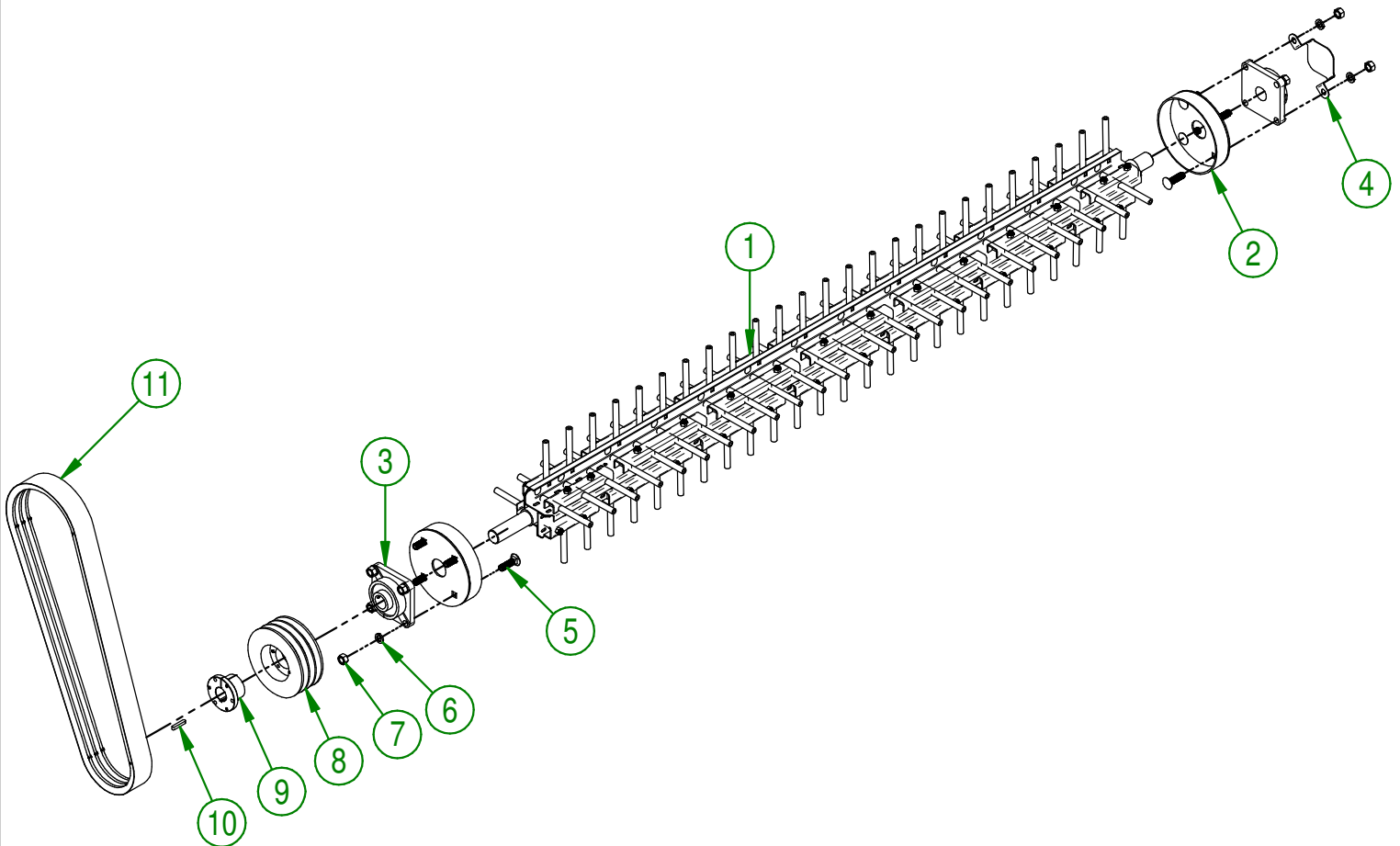

AGRIMETAL	
OPT.6' RUBBER FINGER ROTARY BRUSH	
CREATION : 17/07/17	ASSEMBLY : 29-57-0011
REVISION : 07/05/18	AUTHOR : J.KABWE

#	PART #	Qty	TITLE
1	29-50-0106	1	RUBBER FINGER ROTOR ONLY
2	28-01-7615	20	RUBBER FINGER HOLDER
3	28-01-7620	4	RUBBER FINGER HOLDER
4	29-01-7550	2	RUBBER FINGER HOLDER
5	29-01-7553	2	RUBBER FINGER STOP
6	NC13-15-0348	100	RUBBER FINGER
7	NC01-04-0059	56	CARR. BOLT GR2 5/16-18 X 1 1/4
8	NC01-96-0010	56	NYLON NUT HEX. ZINC 5/16-18
9	29-03-0000	2	RUBBER FINGER STOP
10	29-03-0005	2	RUBBER FINGER HOLDER
11	28-03-0005	4	RUBBER FINGER STOP
12	28-03-0000	20	RUBBER FINGER STOP

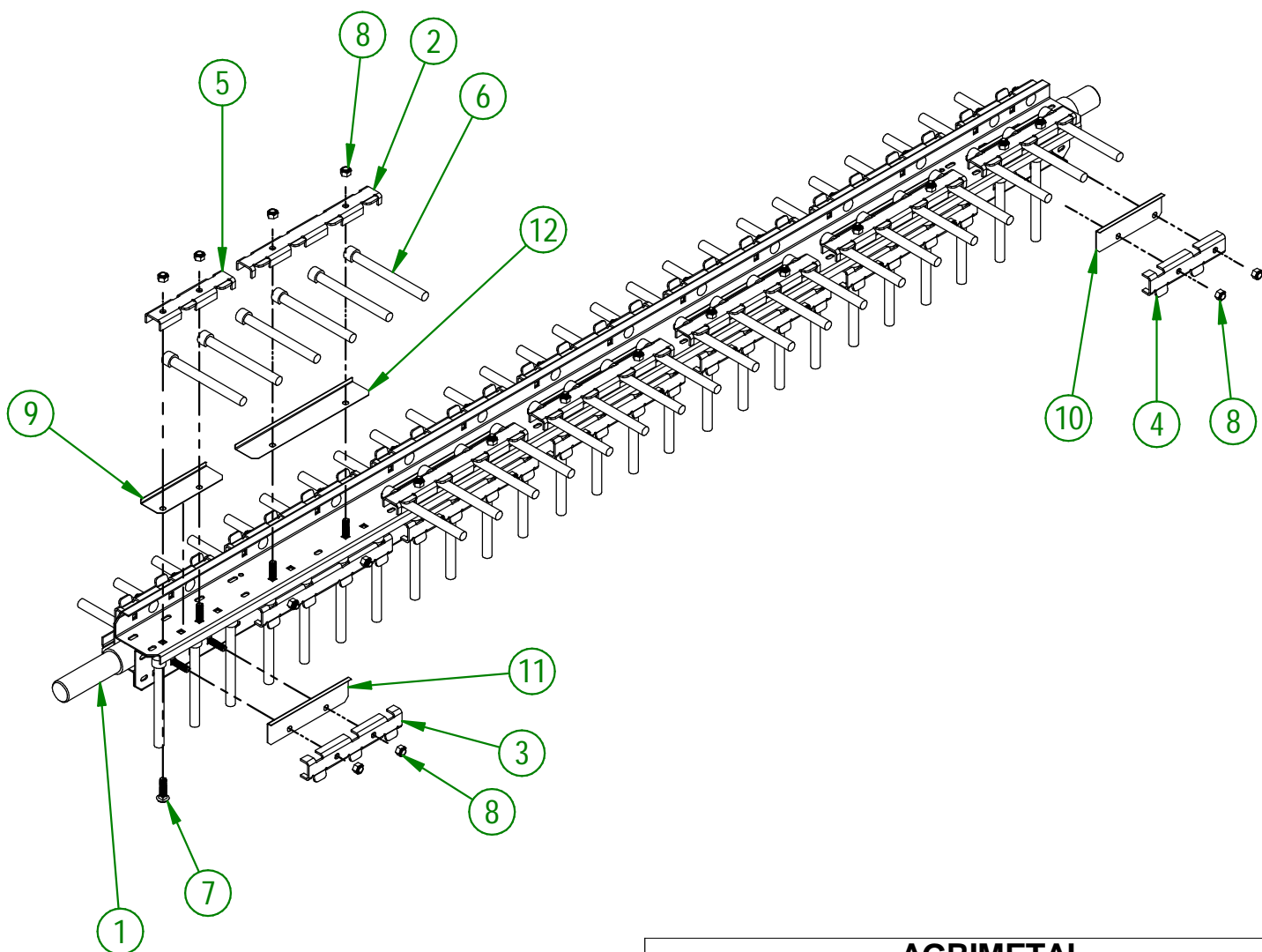

AGRIMETAL	
OPT.6' RUBBER FINGER ROTARY BRUSH	
CREATION : 17/07/17	ASSEMBLY : 29-55-0021
REVISION : 24/10/22	AUTHOR : J.KABWE

#	PART #	Qty	TITLE
1	29-13-1415	1	ROLLER SHAFT 1" DIA. X 14.313"
2	NC14-75-0070	2	6205-2RS BEARING
3	28-42-0120	2	SPACER
4	NC02-32-0014	2	LOCK WASHER ZINC 1/2"
5	NC01-17-0247	2	HEX. BOLT GR2 ZINC 1/2-13 X 1"
6	29-46-0050	1	ROLLER Ø 8"

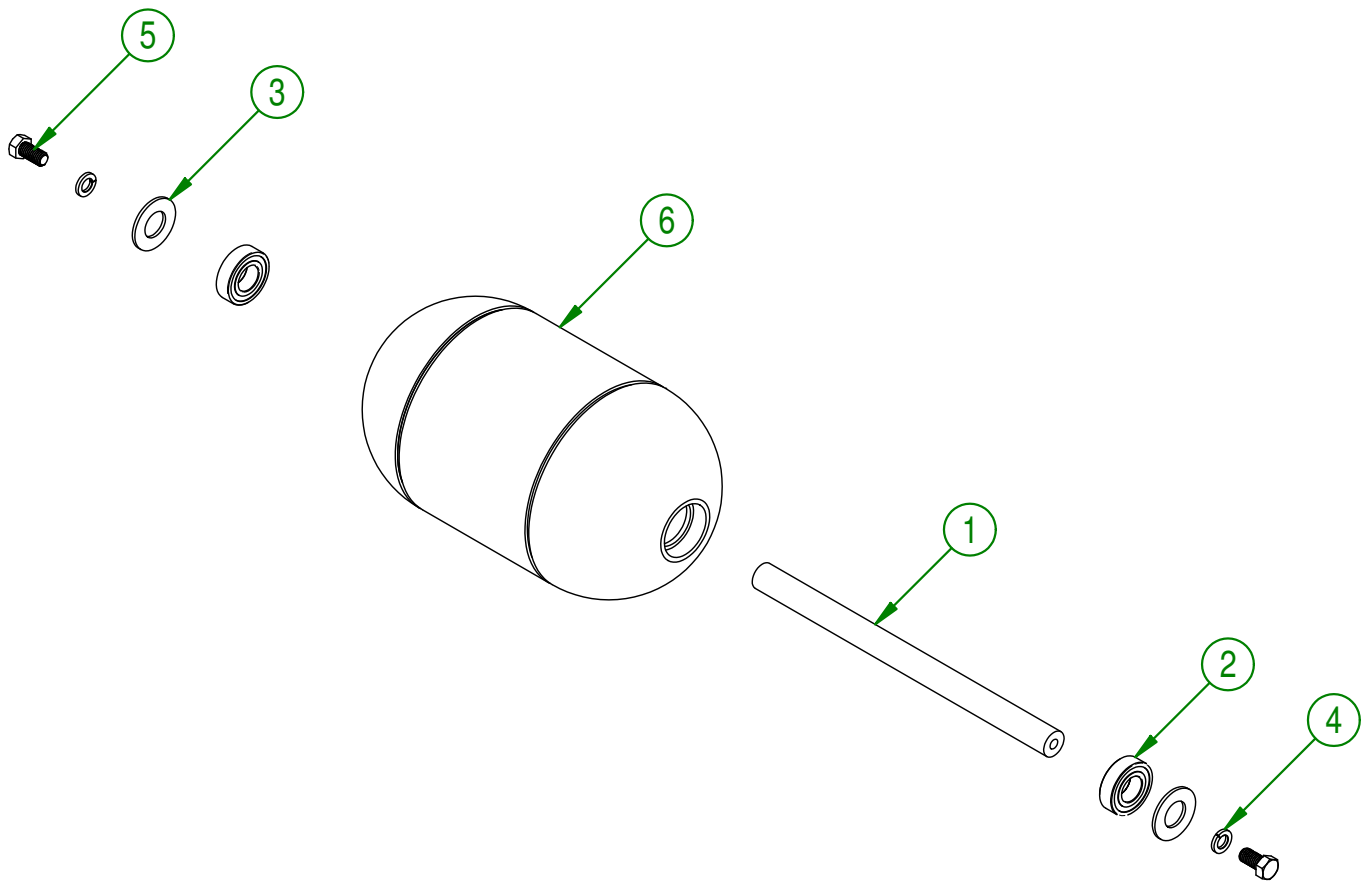

AGRIMETAL	
TURF ROLLER	
CREATION : 17/07/17	ASSEMBLY : 29-57-0013
REVISION : 15/11/18	AUTHOR : J.KABWE Page 45 de 72

#	PART #	Qty	TITLE
1	29-50-0070	1	ROLLER HOLDER
2	28-13-2040	2	PIVOT ROLLER
3	01-01-1660	2	WASHER SPACER
4	NC02-25-0011	2	WASHER SAE ZINC 17/32 ID
5	NC01-17-0251	2	HEX. BOLT GR2 ZINC 1/2-13 X 2"
6	NC02-32-0014	2	LOCK WASHER ZINC 1/2"
7	NC02-07-0020	2	HEX. NUT ZINC 1/2-13

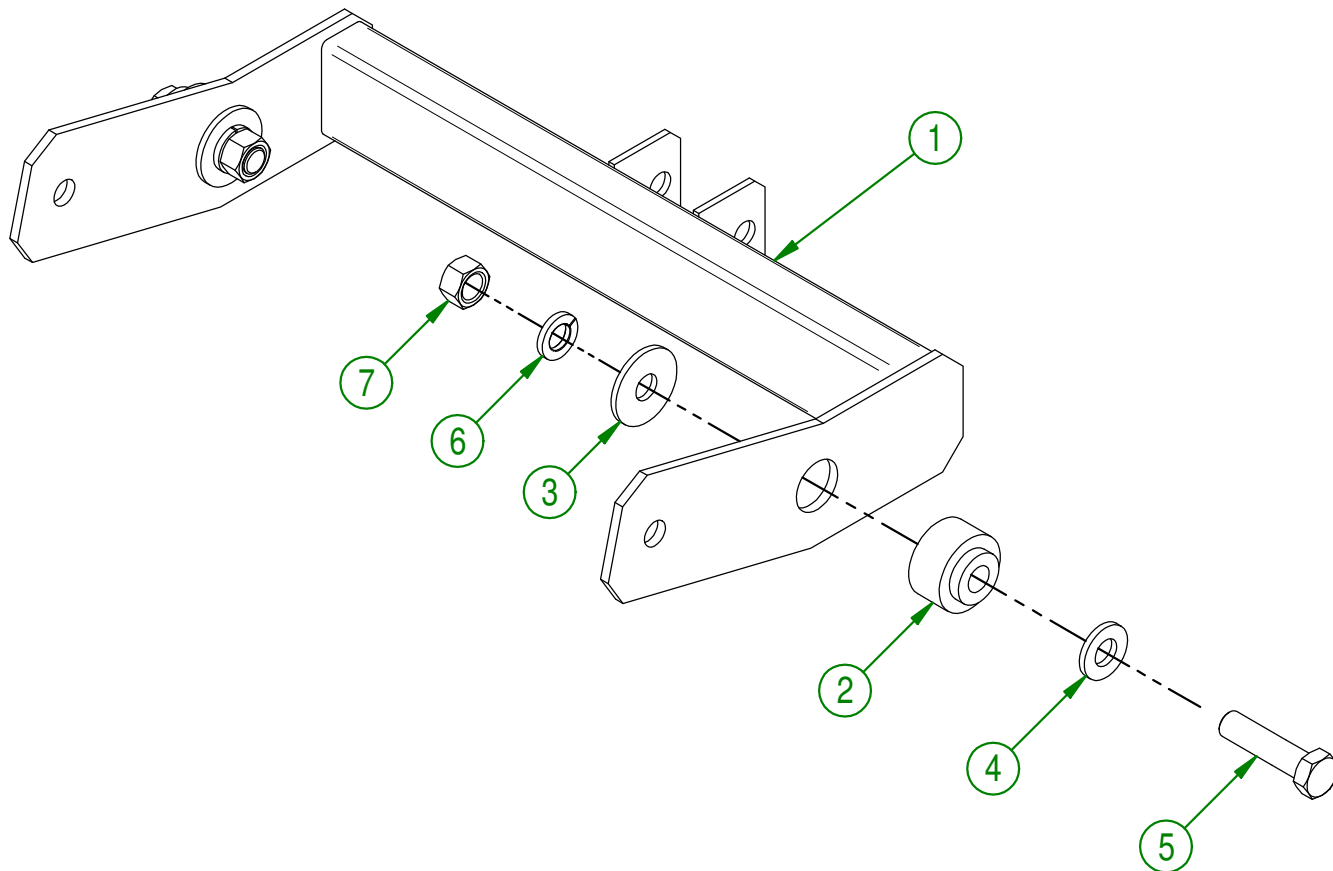

AGRIMETAL	
ROLLER HOLDER	
CREATION : 17/07/17	ASSEMBLY : 29-57-0014
REVISION : 25/01/18	AUTHOR : J.KABWE Page 46 de 72

28-57-0017

#	PART #	Qty	TITLE
1	28-57-0015	1	ADJUSTABLE JACK GROUP (LEFT)
2	28-57-0016	1	ADJUSTABLE JACK GROUP (RIGHT)
3	28-01-1035	4	UNION BRACKET
4	NC02-25-0011	8	WASHER SAE ZINC 17/32 ID
5	NC01-17-0253	2	HEX. BOLT GR2 ZINC 1/2-13 X 2 1/2"
6	NC01-17-0255	2	HEX. BOLT GR2 ZINC 1/2-13 X 3"
7	NC01-93-0014	4	LOCK NUT ZINC 1/2-13
8	NC01-69-1300	2	LOCKING PIN 1/4" DIA. X 2 1/2" GRIP X 1 5/8" H AC ZINC

28-57-0015 / 28-57-0016

#	PART #	Qty	TITLE
8	28-50-0070	1	MANUAL ACTUATOR MOBILE SQUARE TUBE
9	28-50-0075	1	MANUAL ACTUATOR FIXED TUBE
10	28-42-0105	2	TRUST WASHER
11	01-33-0035	2	FLAT WASHER Ø 1 1/4" X Ø 49/64" X 10 GA.
12	NC01-69-0419	2	SPRING TIGHTENER PIN ZINC 3/16 XI"
13	28-04-0600	1	ROTATING PLATE (MANUAL ACTUATOR)
14	NC17-46-0018	1	HANDLE KNOB
15	NC01-17-0122	1	HEX. BOLT GR2 ZINC 3/8-16 X 3"
16	01-01-2485	1	FLAT WASHER 14 GA X 13/16"OD X 25/64" ID
17	NC01-96-0011	1	NYLON NUT 3/8-16
18	NC01-69-0429	1	SPRING PIN ZINC 3/16" X 1 3/4"
19	28-31-1150	1	MANUAL ACTUATOR ACME ROD
20	NC01-04-0107	4	CARR. BOLT GR2 ZINC 3/8-16 X 3/4"
21	NC02-32-0012	4	LOCK WASHER ZINC 3/8"
22	NC02-07-0018	4	HEX. NUT ZINC 3/8-16

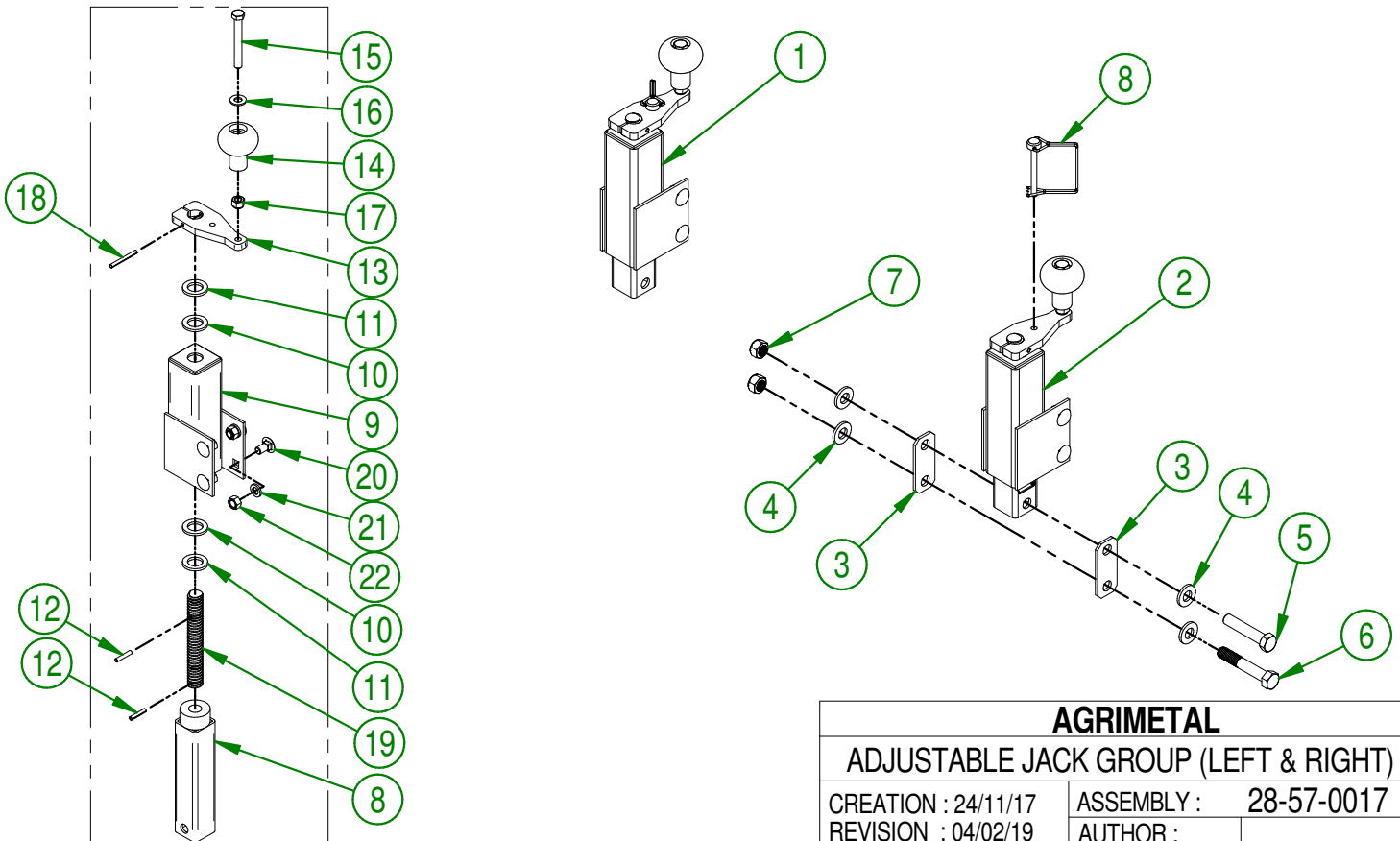

AGRIMETAL	
ADJUSTABLE JACK GROUP (LEFT & RIGHT)	
CREATION : 24/11/17	ASSEMBLY : 28-57-0017
REVISION : 04/02/19	AUTHOR :

#	PART #	Qty	TITLE
1	28-13-1435	1	ROLLER SHAFT 1" DIA. X 18.775"
2	NC14-75-0070	2	6205-2RS BEARING
3	28-42-0145	2	FLAT WASHER 2" DIA. X .313" (UHMW)
4	NC02-32-0014	2	LOCK WASHER ZINC 1/2"
5	NC01-17-0247	2	HEX. BOLT GR2 ZINC 1/2-13 X 1"
6	28-46-0000	1	ROLLER Ø 8"
7	NC02-25-0011	2	WASHER SAE ZINC 17/32 ID

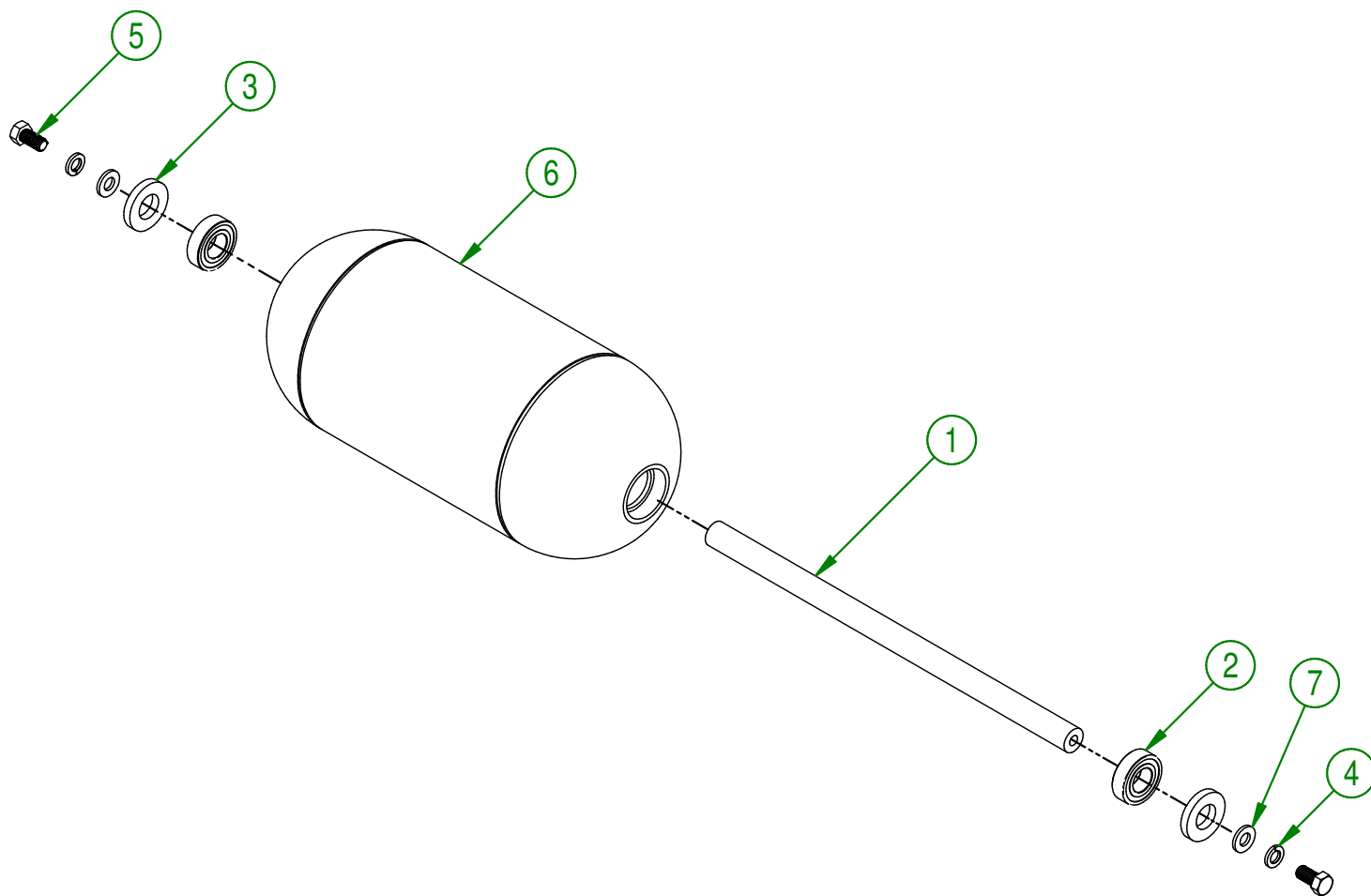

AGRIMETAL
TURF ROLLER ASSY.

CREATION : 17/07/17
REVISION : 15/11/18

ASSEMBLY : **28-57-0020**
AUTHOR : J.KABWE

28-57-0370

#	PART #	Qty	TITLE
1	28-55-0180	3	BRUSH TRACTION ARM
2	NC01-29-0466	3	HEX. BOLT GR5 NF ZINC 3/4-16 X I 3/4"
3	NC01-98-0017	3	HEX. BLOC NUT NYLO. SPEC. 3/4-16
4	NC01-69-1100	3	LINCH PIN 3/8"

28-55-0180

#	PART #	Qty	TITLE
5	28-20-0080	1	BRUSH TRACTION ARM
6	NC02-04-0017	1	HEX. NUT 3/4-16
7	NC01-67-0108	2	TIE ROD END 3/4-16

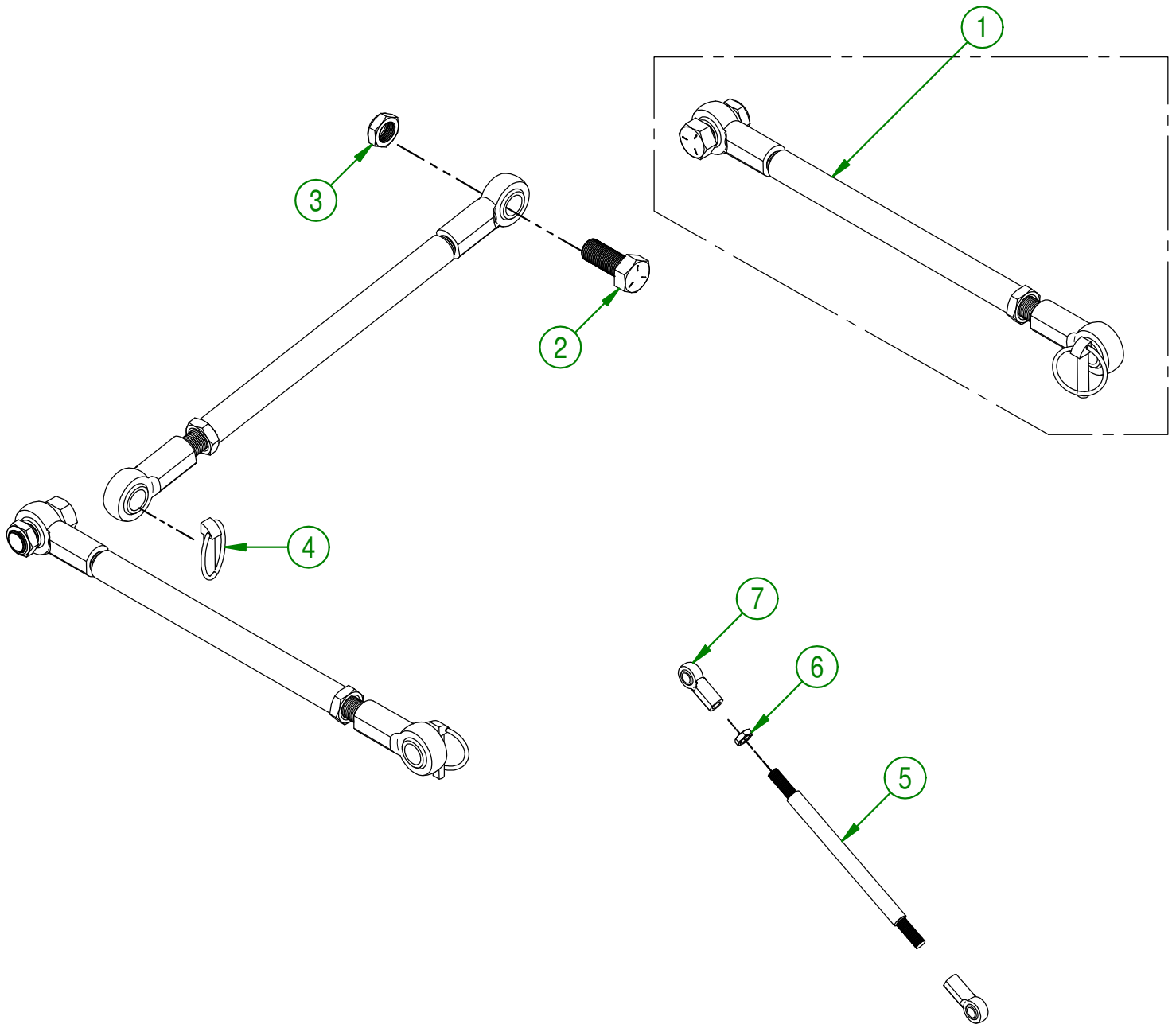

AGRIMETAL	
BRUSH TRACTION ARM REGROUP.	
CREATION : 17/07/17	ASSEMBLY : 28-57-0370
REVISION : 25/01/18	AUTHOR : J.KABWE Page 49 de 72

28-55-0360

#	PART #	Qty	TITLE
1	28-57-0080	1	BRUSH BELT-TIGHTENER BASE MOUNT
2	NC14-75-0113	2	PILLOW BLOCK UCP207-22 I 3/8" DIA. JAPAN ONLY
3	NC01-17-0396	4	HEX. BOLT GR2 ZINC 5/8-11 X 2"
4	NC02-32-0016	4	LOCK WASHER ZINC 5/8"
5	NC02-07-0022	4	HEX. NUT ZINC 5/8-11
6	28-20-0065	1	DRIVE SHAFT
7	28-41-0905	1	SQUARE KEY ROUND END
8	NC01-64-0018	2	EXTERNAL RETAINING RING I 3/8" DIA. ROD

28-57-0080

#	PART #	Qty	TITLE
9	28-50-0030	1	BELT-TIGHTENER BASE
10	28-04-0120	1	ADJUSTABLE HINGE
11	28-09-1220	2	BUSHING
12	01-01-1660	2	WASHER SPACER
13	NC01-17-0249	2	HEX. BOLT GR2 ZINC 1/2-13 X 1 1/2"
14	01-01-0925	2	WASHER
15	NC02-32-0014	2	LOCK WASHER ZINC 1/2"
16	NC02-07-0020	2	HEX. NUT ZINC 1/2-13

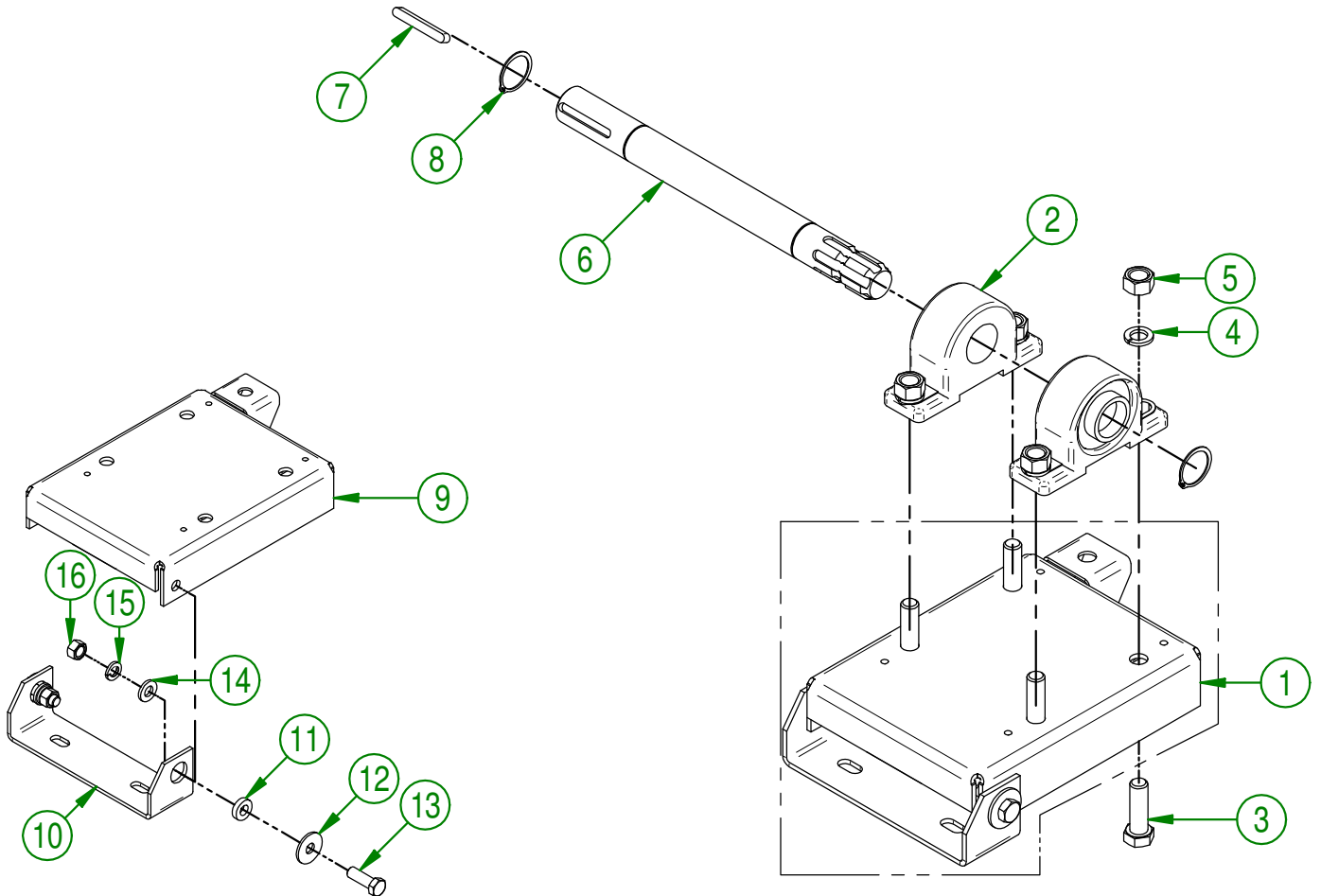

AGRIMETAL	
BELT-TIGHTENER BASE MOUNT	
CREATION : 18/07/17	ASSEMBLY : 28-55-0360
REVISION : 25/01/18	AUTHOR : J.KABWE Page 50 de 72

#	PART #	Qty	TITLE
1	29-57-0120	1	DOOR "STICKER INCLUDED"
2	29-55-0095	1	LEFT DOOR ARM
3	01-33-0010	2	WASHER
4	NC02-32-0012	4	LOCK WASHER ZINC 3/8"
5	NC01-17-0114	4	HEX. BOLT GR2 ZINC 3/8-16 X 1"
6	29-55-0096	1	RIGTH DOOR ARM
7	29-50-0050	2	VERTICAL DOOR ARM
8	28-09-1235	2	BUSHING
9	01-01-1660	8	WASHER SPACER
10	NC01-17-0252	4	HEX. BOLT GR2 ZINC 1/2-13 X 2 1/4"
11	NC02-32-0014	4	LOCK WASHER ZINC 1/2"
12	NC02-07-0020	4	HEX. NUT ZINC 1/2-13
13	NC01-69-1100	2	LINCH PIN 3/8"
14	28-09-1220	2	BUSHING
15	29-04-0170	1	DOOR GUIDE
16	21-01-0950	2	FLAT WASHER IOGA 1.005" DIA X 25/64"
17	29-04-0171	1	DOOR GUIDE (RIGHT)

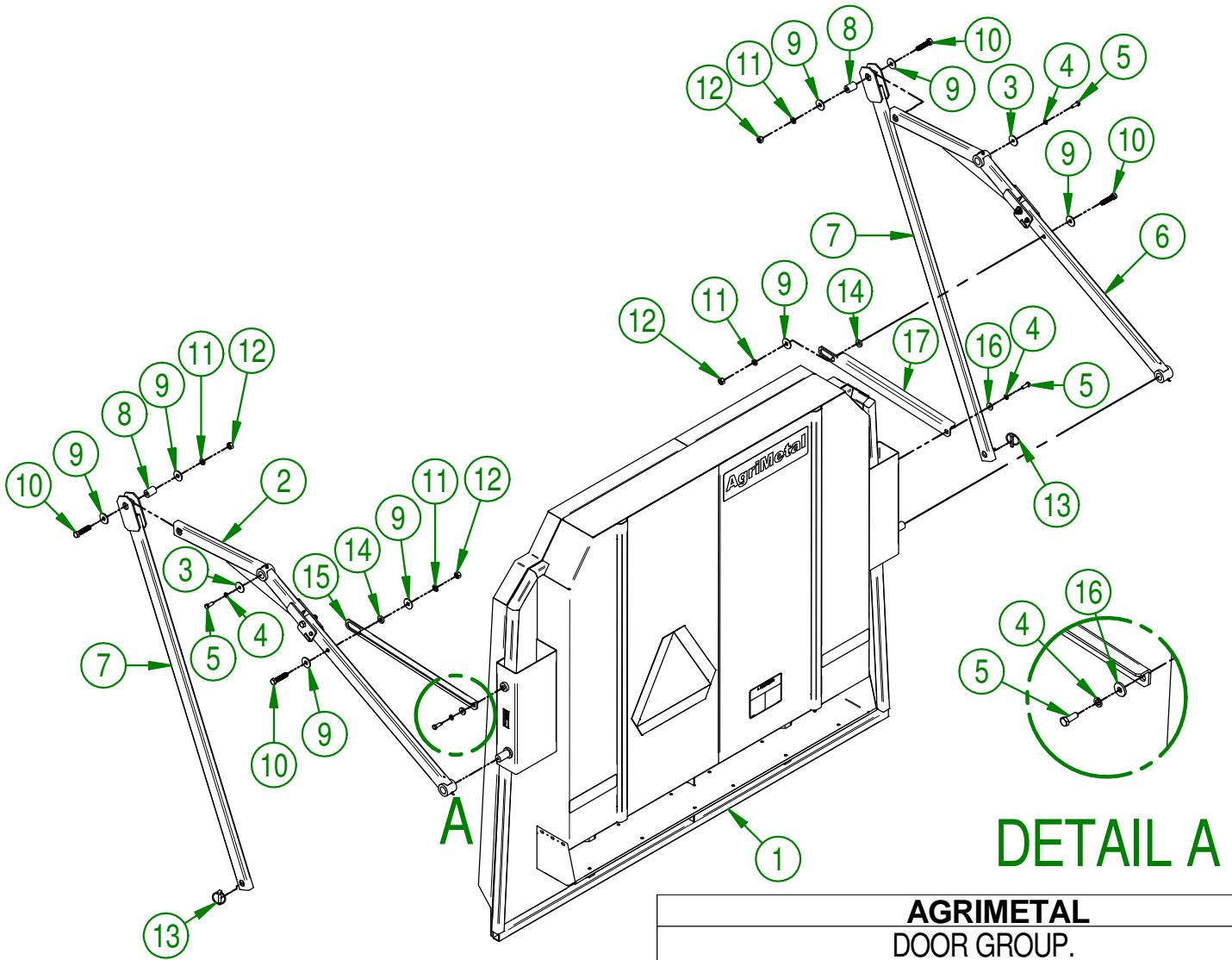

AGRIMETAL
DOOR GROUP.

CREATION : 20/07/17
REVISION : 25/01/18

ASSEMBLY : **29-57-0121**
AUTHOR : J.KABWE Page 51 de 72

29-57-0125

#	PART #	Qty	TITLE
1	29-55-0095	1	LEFT DOOR ARM
2	01-33-0010	1	WASHER
3	NC02-32-0012	1	LOCK WASHER ZINC 3/8"
4	NC01-17-0114	1	HEX. BOLT GR2 ZINC 3/8-16 X 1"

29-55-0095

#	PART #	Qty	TITLE
5	29-50-0080	1	DOOR ARM
6	28-50-0081	1	DOOR ARM
7	NC01-17-0252	1	HEX. BOLT GR2 ZINC 1/2-13 X 2 1/4"
8	NC02-25-0011	1	WASHER SAE ZINC 17/32 ID
9	NC01-96-0014	1	NYLON-INSERT LOCKNUT ZINC 1/2-13
10	NC01-17-0010	1	HEX. BOLT GR2 NC ZINC 1/4-20 X 2"
11	NC02-25-0007	1	WASHER ZINC 0.281 = 9/32
12	NC01-96-0009	1	NYLON-INSERT LOCKNUT ZINC 1/4-20
13	NC01-69-0785	2	STRAIGHT GREASE FITTING 1/4-28

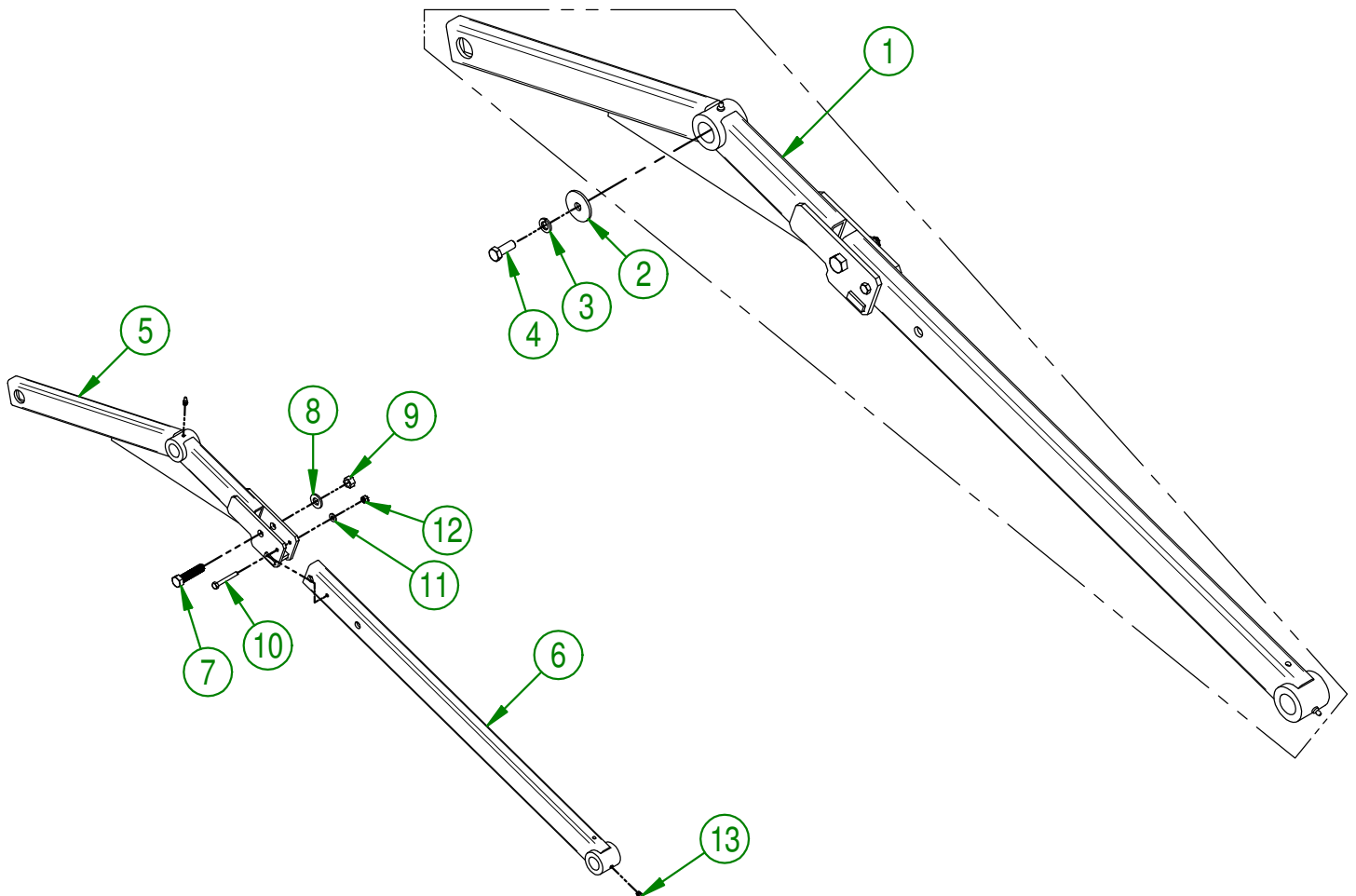

AGRIMETAL
LEFT DOOR ARM GROUP.

CREATION : 19/07/17
REVISION : 26/01/18

ASSEMBLY : **29-57-0125**

AUTHOR : J.KABWE | Page 52 de 72

29-57-0126

#	PART #	Qty	TITLE
1	29-55-0096	1	RIGTH DOOR ARM
2	01-33-0010	1	WASHER
3	NC02-32-0012	1	LOCK WASHER ZINC 3/8"
4	NC01-17-0114	1	HEX. BOLT GR2 ZINC 3/8-16 X 1"

29-55-0096

#	PART #	Qty	TITLE
5	29-50-0080	1	DOOR ARM
6	28-50-0081	1	DOOR ARM
7	NC01-17-0252	1	HEX. BOLT GR2 ZINC 1/2-13 X 2 1/4"
8	NC02-25-0011	1	WASHER SAE ZINC 17/32 ID
9	NC01-96-0014	1	NYLON-INSERT LOCKNUT ZINC 1/2-13
10	NC01-17-0010	1	HEX. BOLT GR2 NC ZINC 1/4-20 X 2"
11	NC02-25-0007	1	WASHER ZINC 0.281 = 9/32
12	NC01-96-0009	1	NYLON-INSERT LOCKNUT ZINC 1/4-20
13	NC01-69-0785	2	STRAIGHT GREASE FITTING 1/4-28

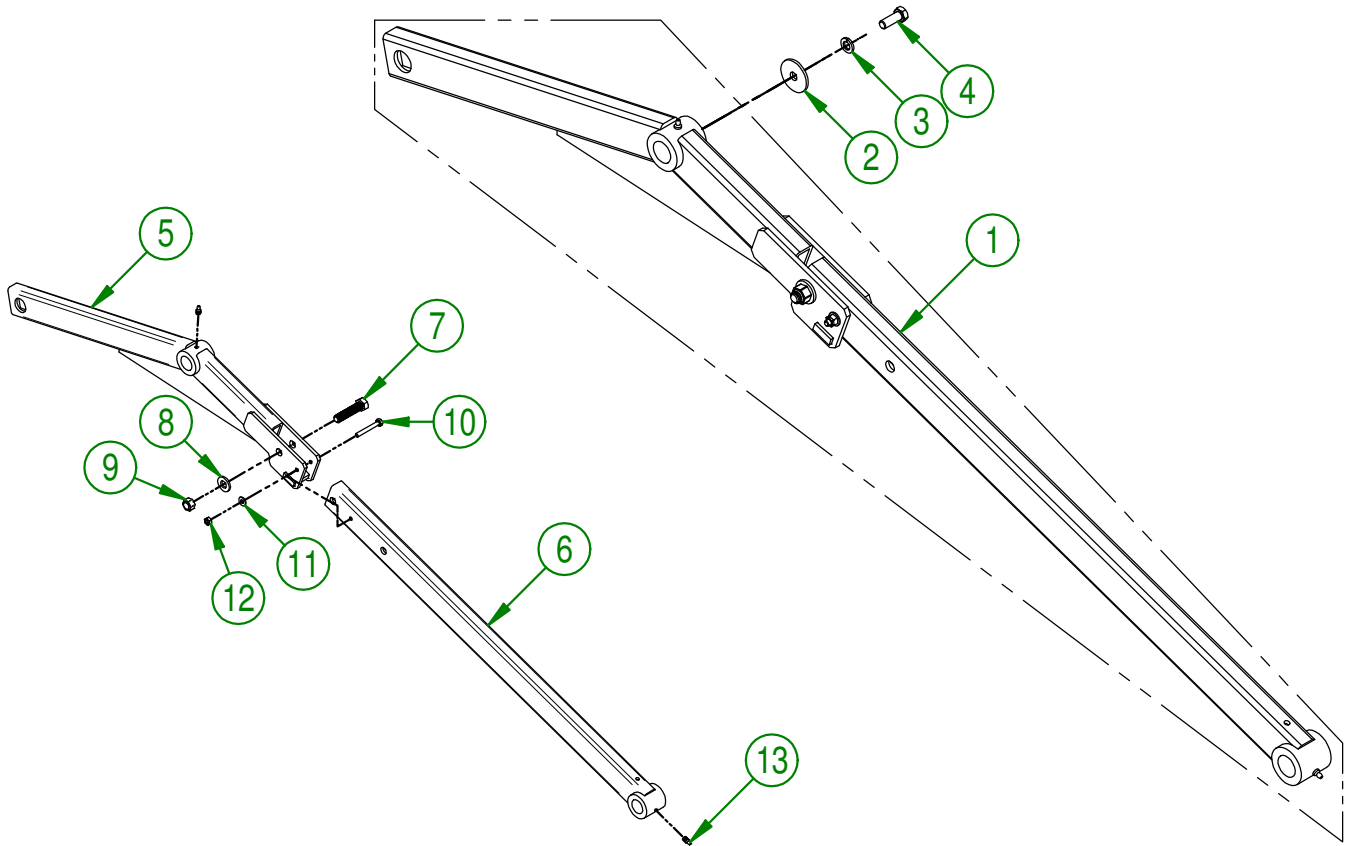

AGRIMETAL
RIGHT DOOR ARM GROUP.

CREATION : 19/07/17
 REVISION : 26/01/18

ASSEMBLY : **29-57-0126**

AUTHOR : J.KABWE Page 53 de 72

#	PART #	Qty	TITLE
1	29-57-0145	1	PICK-UP HEAD GUARD'S PTO (LEFT) "STICKER INCLUDED"
2	NC01-17-0114	4	HEX. BOLT GR2 ZINC 3/8-16 X 1"
3	01-01-2485	4	FLAT WASHER
4	NC02-32-0012	4	LOCK WASHER ZINC 3/8"

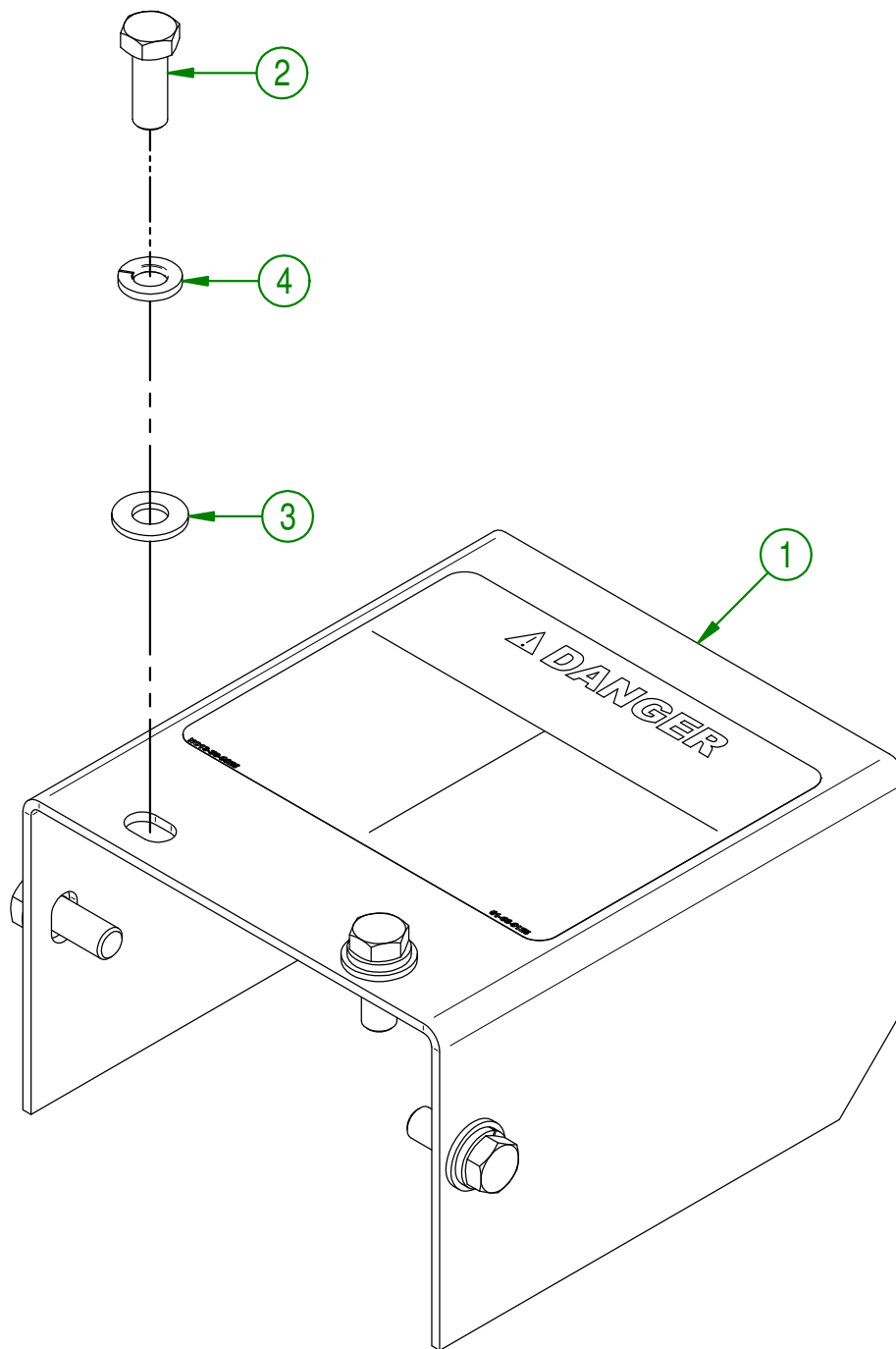
**AGRIMETAL****PICK-UP HEAD GUARD'S PTO (LEFT) GROUP.**

CREATION : 20/07/17
 REVISION : 26/01/18

ASSEMBLY : **29-57-0146**

AUTHOR : J.KABWE Page 54 de 72

28-57-0180

#	PART #	Qty	TITLE
1	NCI3-30-0237	1	PLASTIC TUBE FOR OPERATOR'S MANUAL
2	NC01-04-0002	3	CARR. BOLT GR2 ZINC 1/4-20 X 5/8"
3	NC02-14-0017	3	FLANGED NUT GR. B 1/4-20
4	28-98-0501	1	OPERATIONAL MANUAL

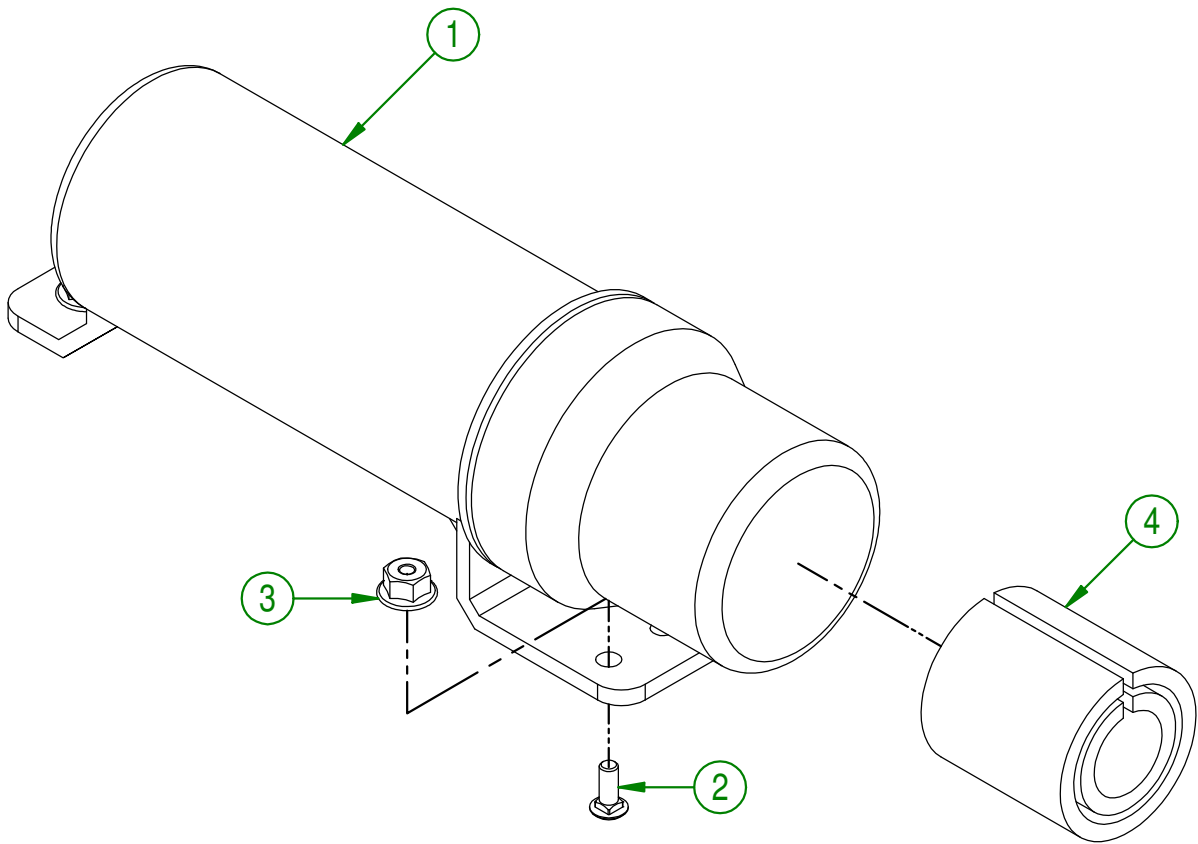

AGRIMETAL	
OPERATIONAL MANUAL GROUP.	
CREATION : 20/07/17	ASSEMBLY : 28-57-0180
REVISION : 26/01/18	AUTHOR : J.KABWE Page 55 de 72

#	PART #	Qty	TITLE
1	NC13-40-0008	1	FLEXIBLE HOSE 8" DIA. (16' LG)

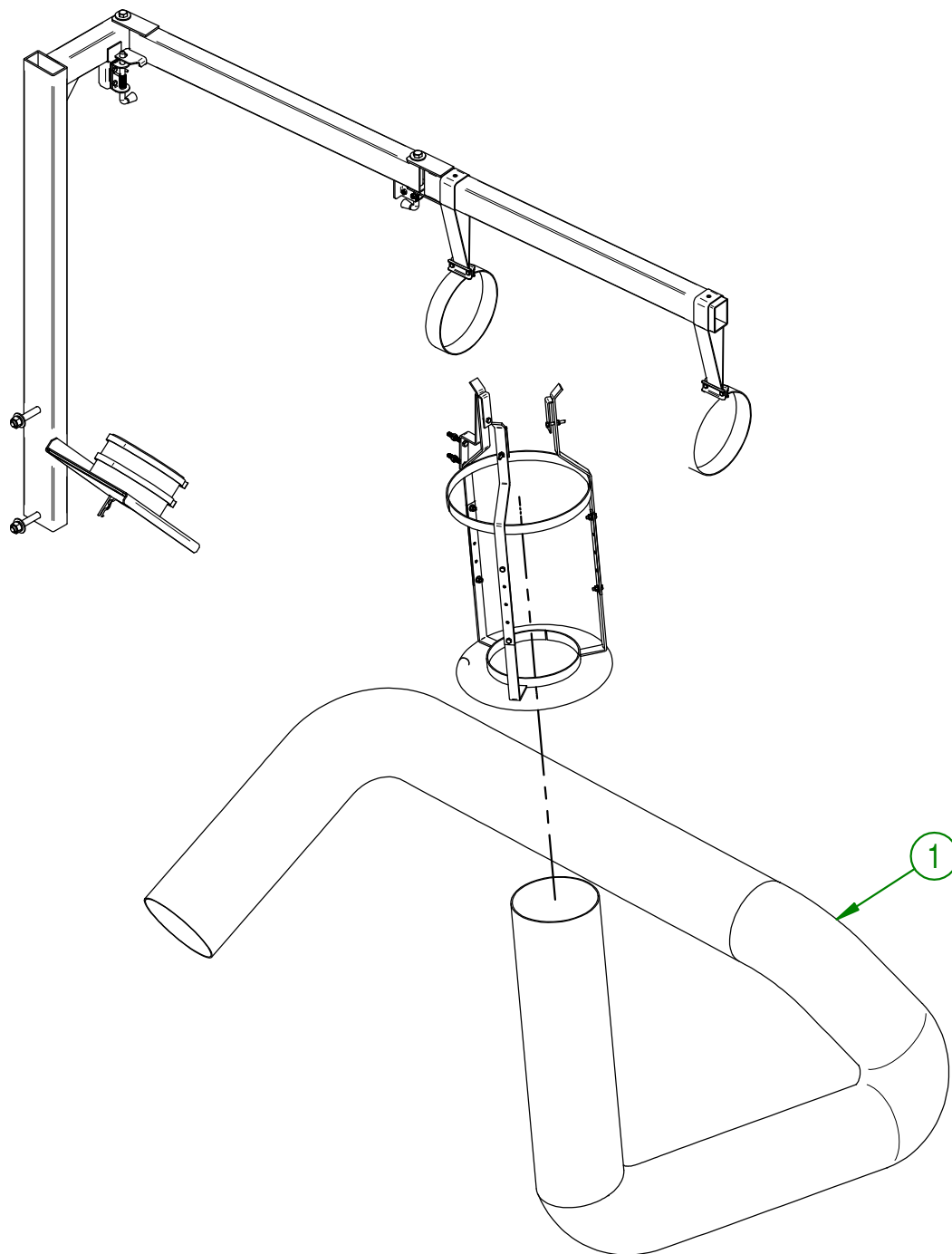

AGRIMETAL	
OPT. HOSE KIT	
CREATION : 05/09/17	ASSEMBLY : 29-55-0040
REVISION : 26/01/18	AUTHOR : J.KABWE Page 56 de 72

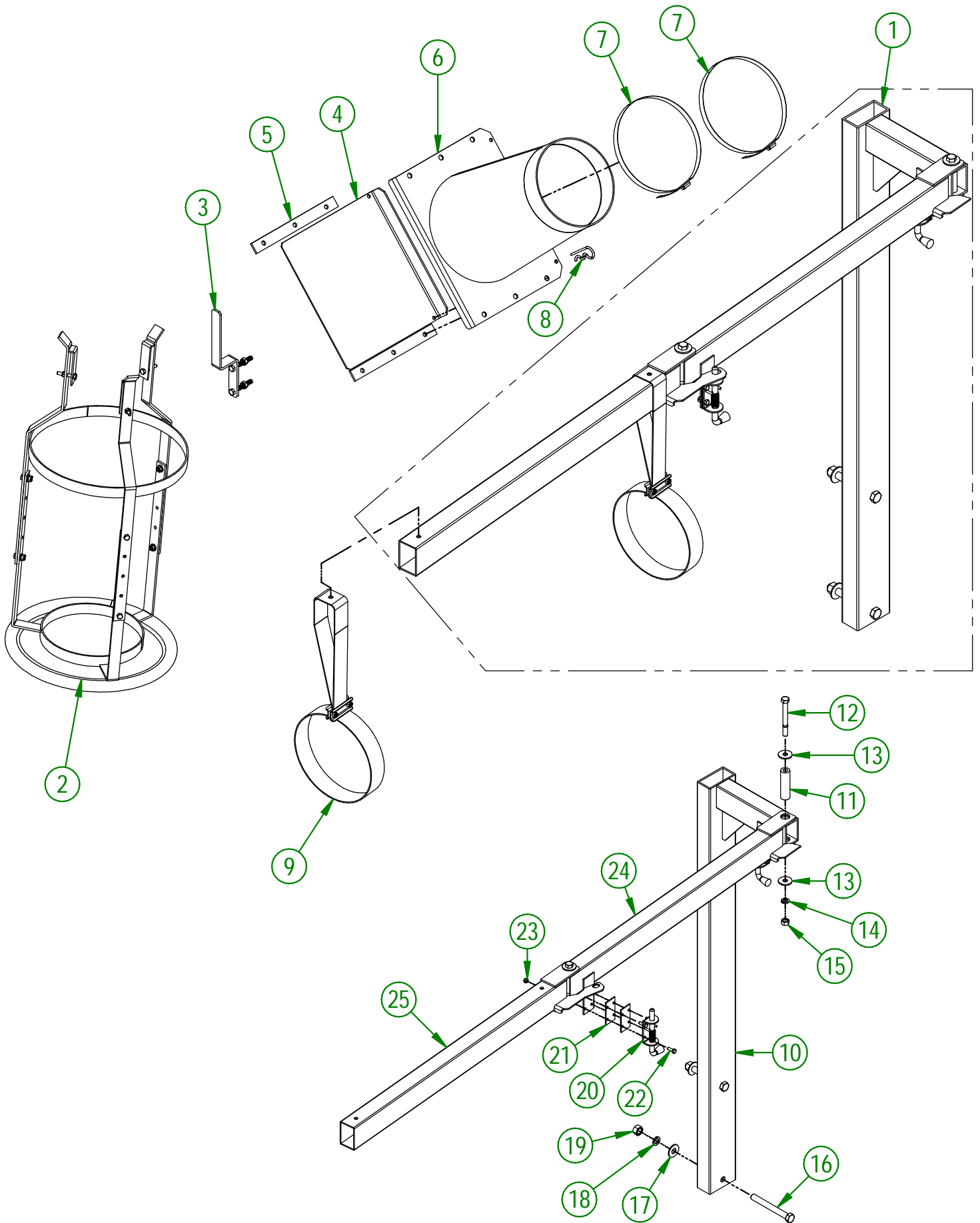

AGRIMETAL

HOSE KIT

CREATION : 23/08/17
 REVISION : 23/08/22

ASSEMBLY : **29-57-0160**

AUTHOR : J.KABWE

29-57-0160

#	PART #	Qty	TITLE
1	29-55-0105	1	STEM ASSY. (OPT.)
2	29-55-0113	1	HOSE HANDLE 8" DIA.
3	29-55-0115	1	HOSE HANDLE 8" SUPPORT
4	29-01-0955	1	HOSE TRAP
5	29-04-0165	2	SHIM FOR HOSE ADAPTOR 8" Dia.
6	29-50-0039	1	HOSE ADAPTOR 8" DIA.
7	NC01-65-0077	2	HOSE CLAMPS (HSI28)
8	NC01-63-0026	1	COTTER PIN ZC 5/32" X 3"
9	16-55-0180	2	HOSE STRAP ASSY.

29-55-0105

#	PART #	Qty	TITLE
10	28-50-0100	1	HOSE SUPPORT
11	28-09-1230	2	PIVOT PIN
12	NC01-17-0261	2	HEX. BOLT GR2 NC ZINC 1/2-13 X 4 1/2" LG
13	01-01-1660	4	WASHER SPACER
14	NC02-32-0014	2	LOCK WASHER ZINC 1/2"
15	NC02-07-0020	2	HEX. NUT ZINC 1/2-13
16	NC01-17-0410	2	HEX. BOLT GR2 NC ZINC 5/8-11 5 1/2"
17	NC02-22-0013	2	WASHER ZINC 5/8 ID X 1 1/2 OD
18	NC02-32-0016	2	LOCK WASHER ZINC 5/8"
19	NC02-07-0022	2	HEX. NUT ZINC 5/8-11
20	NC13-80-0213	2	SPRING ROUND PIN LOCK 1/2" X 1 1/8" COURSE X 6.300" LG
21	28-01-7580	4	SHIM
22	NC01-17-0004	8	HEX. BOLT GR2 ZINC 1/4-20 X 3/4"
23	NC01-97-0004	8	NYLON-INSERT LOCKNUT ZINC 1/4-28
24	28-50-0295	1	FLEXIBLE HOSE SUPPORT (CENTRAL)
25	28-50-0300	1	FLEXIBLE HOSE SUPPORT (END)

AGRIMETAL**HOSE KIT**

CREATION : 23/08/17
 REVISION : 23/08/22

ASSEMBLY : **29-57-0160**
 AUTHOR : J.KABWE

#	PART #	Qty	TITLE
1	NCI3-25-0278	1	FIXING LIGHT REGISTRATION PLATE
2	16-55-0290	2	LIGHT SUPPORT ASSY
3	NCI3-25-0284	1	KRALOY TERMINAL BOX 2" X 2 13/16" X 4 9/16"
4	NCI3-25-0285	1	KRALOY BOX COVER 2 13/16" X 4 9/16"
5	NC02-40-0080	2	MACHINE SCREWS SQUARE SOCKET #10-24 X 1/2" LG
6	16-55-0043	1	TRAILER CONNECTION 4 SPRIGS
7	NCI3-25-0352	2	YELLOW LIGHT SIDE 1 1/8" X 2" X 4"
8	NCI3-25-0110	10	SNUG-FIT DAMPING LOOP CLAMP
9	NC01-78-0016	10	ALUMINIUM BLIND POP RIVET STEEL MANDREL 0.187 X 0.690
10	29-55-0210	1	RIGHT TRAILER WIRE 3 BRINS
11	29-55-0215	1	LEFT TRAILER WIRE 3 BRINS
12	NCI3-25-0228	4	VINYL UNION TERMINAL 16-14
13	NCI3-25-0226	1	BROWN WIRE 16 GA TEW (140")
14	NCI3-25-0108	1	TERMINAL PIN ROUND FEMALE INSULATED FOR WIRE 16 GA
15	NCI3-25-0127	1	WHITE WIRE 16 GA TEW (140")
16	NCI3-25-0007	1	RING TERMINAL 16GA X 1/4" Ø
17	29-46-0000	1	TRANSPARENT VINYL HOSE 5/8" OD X 1/2" ID X 220" LG
18	29-46-0001	1	TRANSPARENT VINYL HOSE 5/8" OD X 1/2" ID X 220" LG
19	29-46-0005	1	TRANSPARENT VINYL HOSE 5/8" OD X 1/2" ID X 130" LG

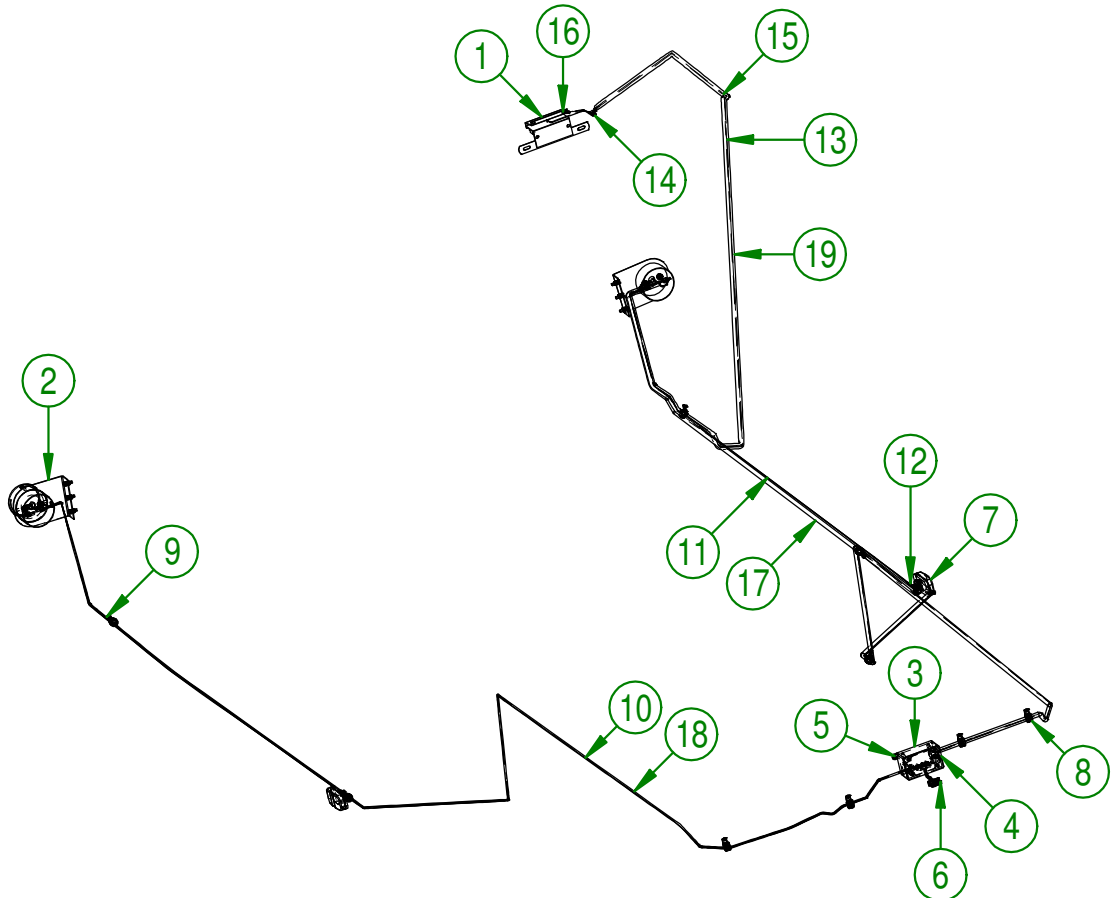

AGRIMETAL	
(OPT) STOP AND TURN LIGHT KIT	
CREATION : 22/08/17	ASSEMBLY : 29-55-0050
REVISION : 26/01/18	AUTHOR : J.KABWE Page 59 de 72

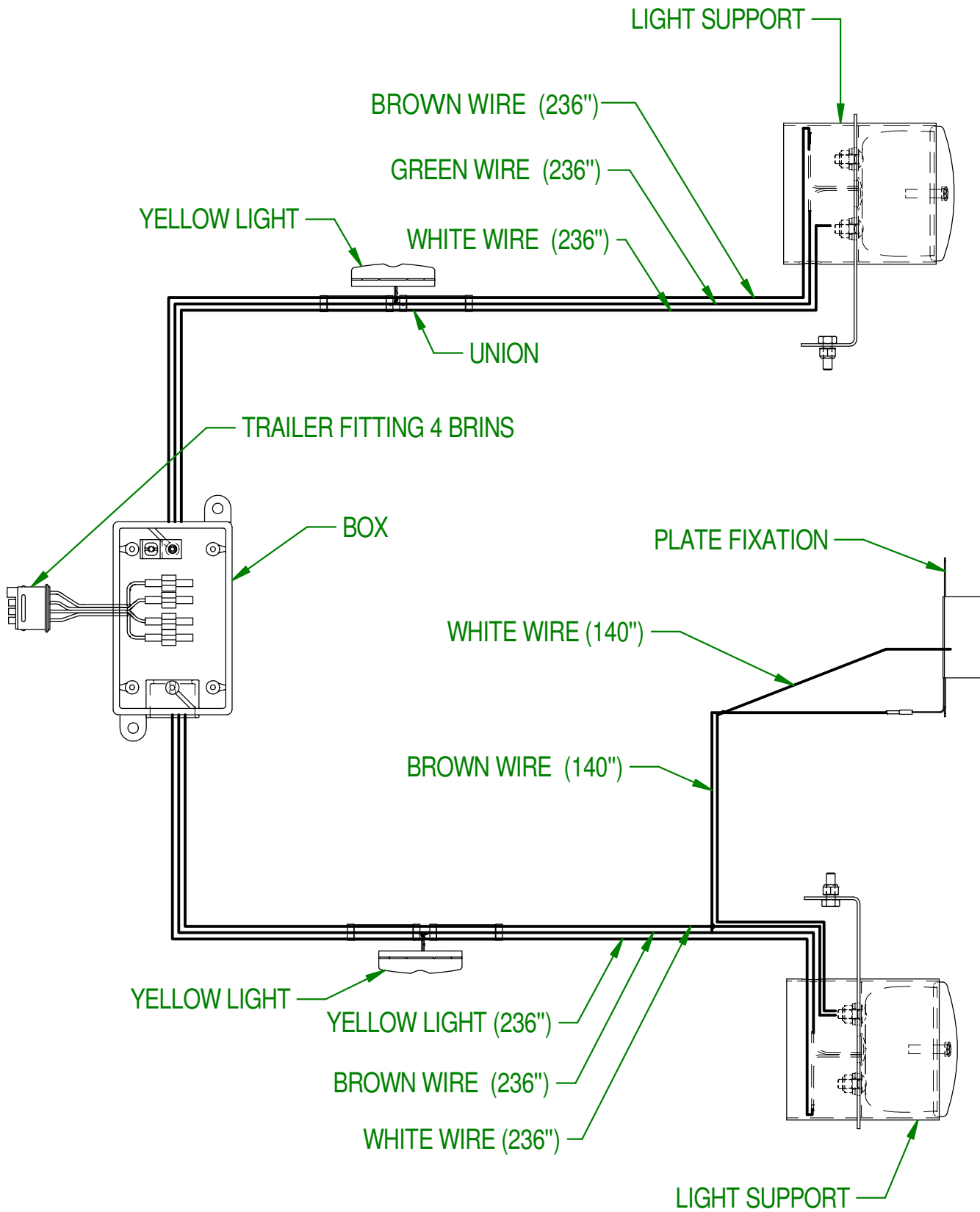

AGRIMETAL	
(OPT) STOP AND TURN LIGHT KIT	
CREATION : 17/11/17	ASSEMBLY : 29-55-0050
REVISION : 26/01/18	AUTHOR : J.KABWE Page 60 de 72

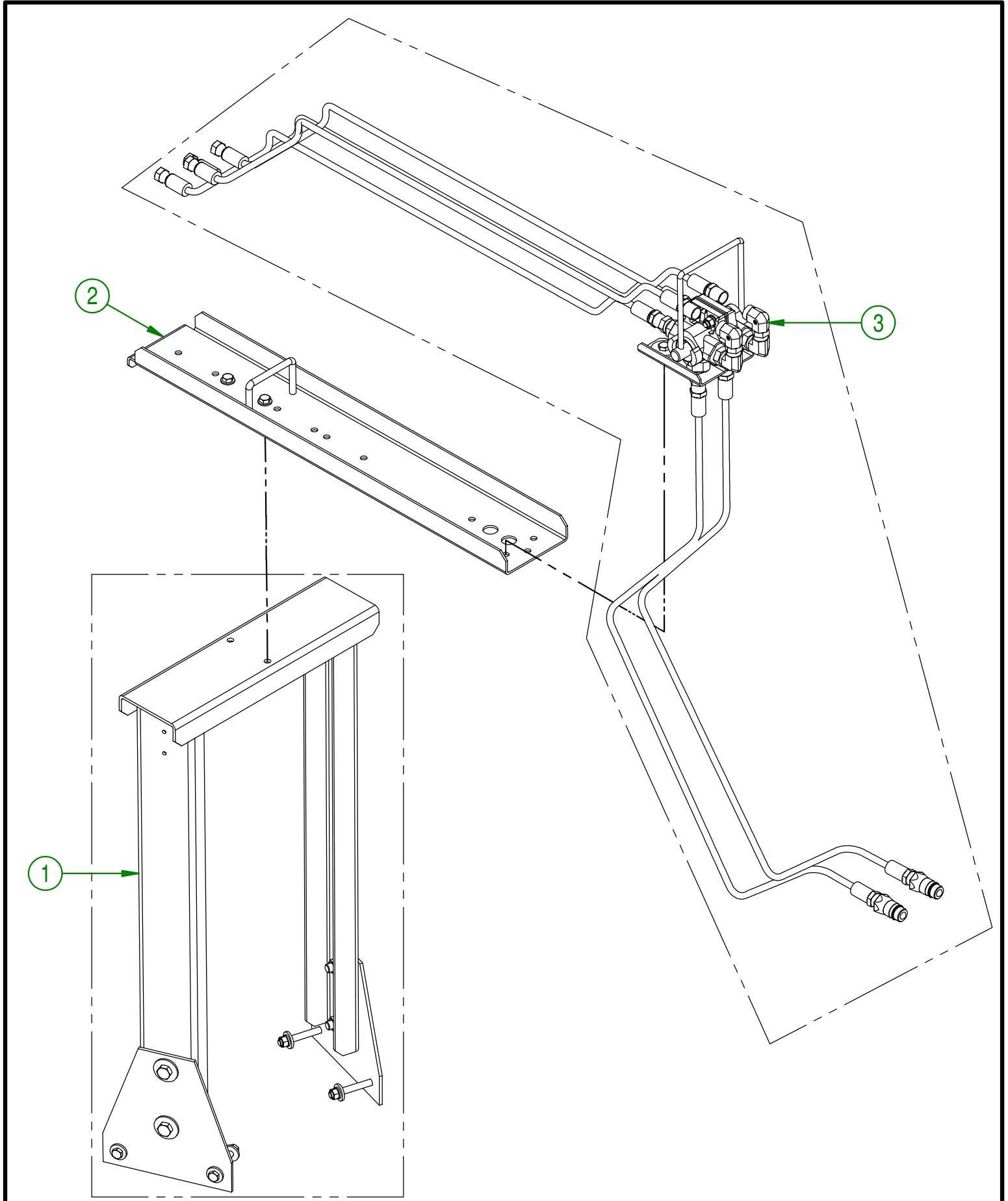

AGRIMETAL	
2-WAYS SPLITTER VALVE (HYDRAULIC)	
CREATION : 28/08/17	ASSEMBLY : 28-55-0055
REVISION : 07/05/18	AUTHOR : J.KABWE Page 61 de 72

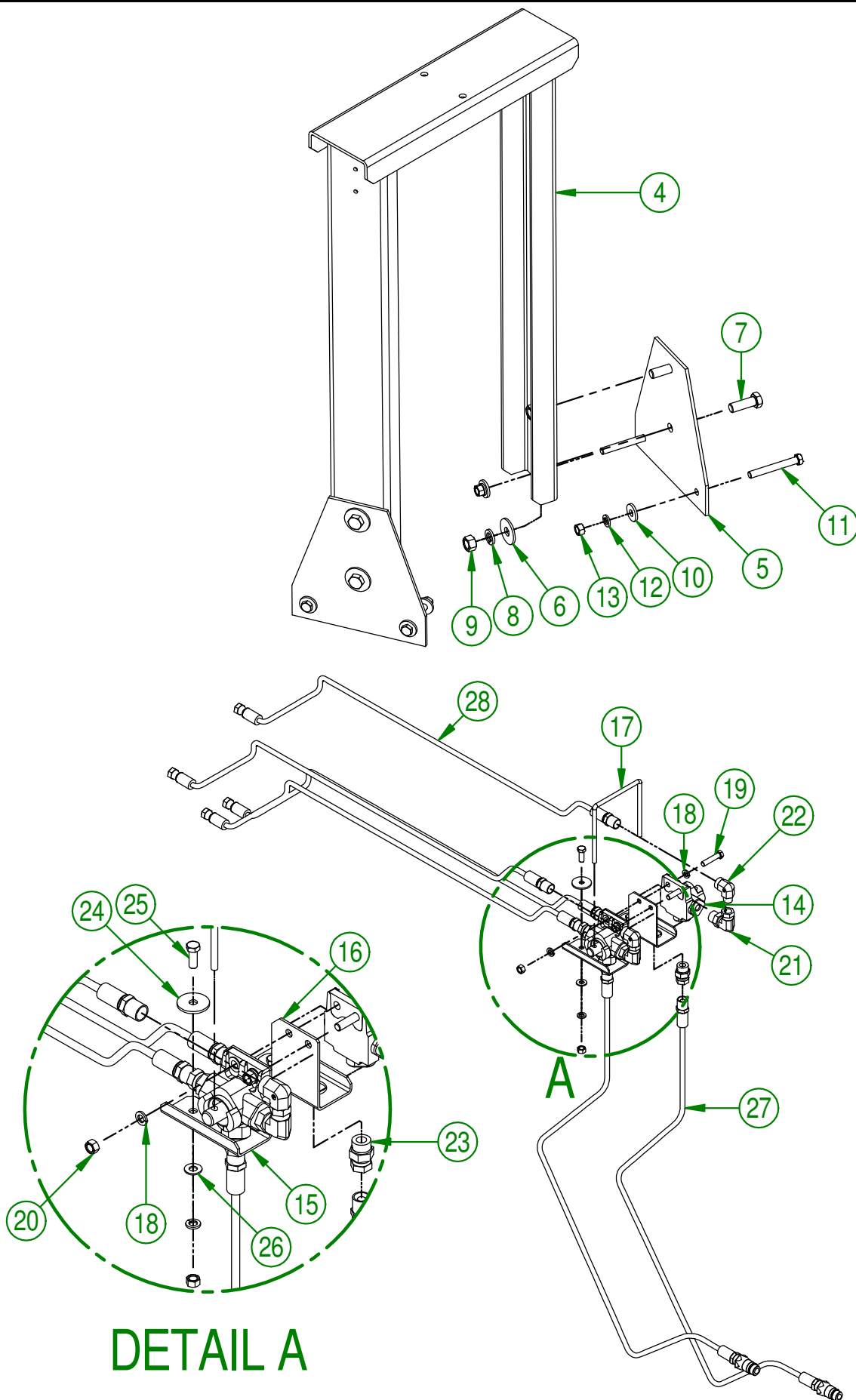

AGRIMETAL	
2-WAYS SPLITTER VALVE (HYDRAULIC)	
CREATION : 28/08/17	ASSEMBLY : 28-55-0055
REVISION : 07/05/18	AUTHOR : J.KABWE Page 62 de 72

28-55-0055

#	PART #	Qty	TITLE
1	28-55-0250	1	HITCH HYDRAULIC HOSE CONTROL SUPPORT
2	16-55-1130	1	ADJUSTABLE HYDRAULIC HOSE SUPPORT ASSY
3	28-55-0255	1	HYDRAULIC VALVE 2 INPUTS / OUTPUTS COMPL.

28-55-0250

#	PART #	Qty	TITLE
4	16-50-2075	1	HYDRAULIC VALVE SUPPORT
5	28-04-0017	2	SUPPORT ADAPTER SPLITTER VALVE
6	01-01-1660	8	WASHER SPACER
7	NC01-17-0249	4	HEX. BOLT GR2 ZINC 1/2-13 X 1 1/2"
8	NC02-32-0014	4	LOCK WASHER ZINC 1/2"
9	NC02-07-0020	4	HEX. NUT ZINC 1/2-13
10	21-01-0950	8	FLAT WASHER 10GA 1.005" DIA X 25/64"
11	NC01-17-0122	4	HEX. BOLT GR2 ZINC 3/8-16 X 3"
12	NC02-32-0012	4	LOCK WASHER ZINC 3/8"
13	NC02-07-0018	4	HEX. NUT ZINC 3/8-16

28-55-0255

#	PART #	Qty	TITLE
14	15-45-0161	2	3 DIRECTIONS CONTROL VALVE (7/8-14 SAE)
15	16-01-2280	1	HYDRAULIC HOSE SUPPORT (LEFT)
16	16-01-2285	1	HYDRAULIC HOSE SUPPORT (RIGHT)
17	16-13-0300	1	HYDRAULIC VALVE SELECTOR
18	NC02-32-0012	6	LOCK WASHER ZINC 3/8"
19	NC01-17-0117	2	HEX. BOLT GR2 ZINC 3/8-16 X 1 3/4"
20	NC02-07-0018	4	HEX. NUT ZINC 3/8-16
21	NC13-45-0072	2	ELBOW 90 7/8-14 MALE SAE10 O-RING X 3/8 FEM. TOUR. NPT
22	NC13-45-0038	2	ELBOW 90 3/8 FEM. NPT X 3/8 MALE NPT
23	NC13-45-0073	4	STRAIGHT 7/8-14 MALE SAE10 O-RING X 3/8 FEM. TOUR. NPT
24	01-33-0010	2	WASHER
25	NC01-17-0114	2	HEX. BOLT GR2 ZINC 3/8-16 X 1"
26	01-01-2485	2	FLAT WASHER
27	16-55-0179	2	HYDR.HOSE 3/8" DIA. X ASSY. "3 WAYS SPLITER VALVE 7/8-14 SA
28	NC17-02-0390	4	HYDRAULIC HOSE 3/8 X 60" X CUT 3/8 NPT MAL. RIG. X 3/8 JIC 37 FEM.

AGRIMETAL**2-WAYS SPLITTER VALVE (HYDRAULIC)**

CREATION : 28/08/17
REVISION : 07/05/18

ASSEMBLY : **28-55-0055**

AUTHOR : J.KABWE Page 63 de 72

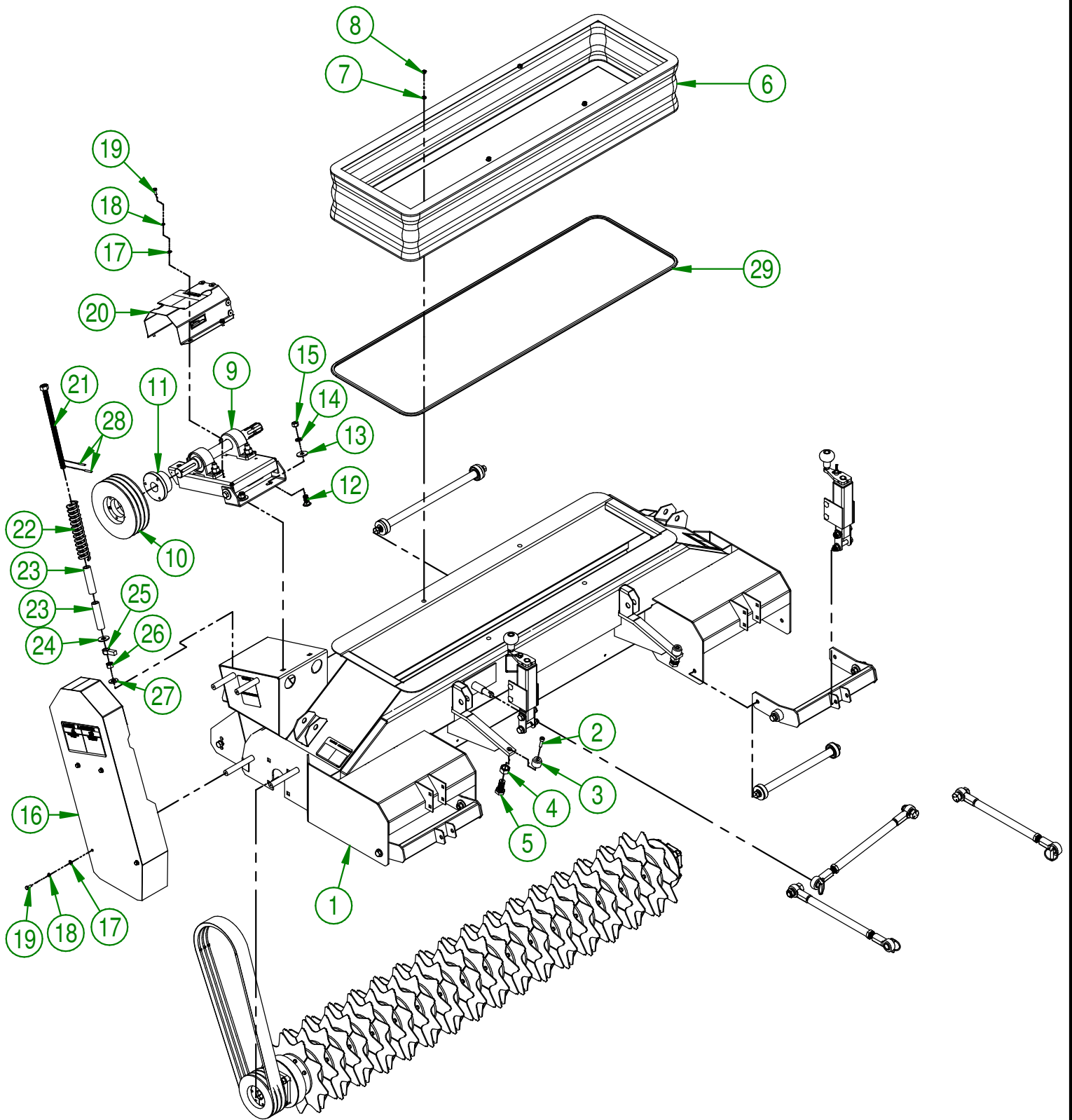

AGRIMETAL

(OPT.) 6' COMPLETE PICK-UP HEAD VERTI-CUT

CREATION : 23/08/17
 REVISION : 16/09/21

ASSEMBLY : **29-55-0036**
 AUTHOR : J.KABWE

#	PART #	Qty	TITLE
1	29-57-0010	1	PICK-UP HEAD "STICKER INCLUDED"
2	NC02-50-0101	2	ALLEN SET SCREWS 5/16-18 X 1 1/4"
3	28-13-1430	2	STABILIZING FERRULE
4	NC02-07-0023	2	HEX. NUT ZINC 3/4-10
5	28-30-9950	2	BOLT 3/4-10 1 3/4"
6	NC17-11-0013	1	EXPANDING BOOT 18 1/2"
7	NC02-22-0008	4	WASHER ZINC 5/16"
8	NC01-96-0009	4	NYLON-INSERT LOCKNUT ZINC 1/4-20
9	28-55-0360	1	BELT-TIGHTENER BASE MOUNT
10	NC14-62-0102	1	CAST IRON SHAVE PULLEY 3B80
11	NC14-62-0020	1	TAPERED QD BUSHING SK 1 3/8"
12	NC01-04-0234	2	CARR. BOLT GR2 ZINC 1/2-13 X 1 1/4
13	01-01-1660	2	WASHER SPACER
14	NC02-32-0014	2	LOCK WASHER ZINC 1/2"
15	NC02-07-0020	2	HEX. NUT ZINC 1/2-13
16	28-57-0030	1	BELT GUARD "STICKER INCLUDED"
17	NC02-25-0007	8	WASHER ZINC 0.281 = 9/32
18	NC02-32-0010	8	LOCK WASHER ZINC 1/4"
19	NC01-17-0003	8	HEX. BOLT GR2 ZINC 1/4-20 X 5/8"
20	28-55-0125	1	PILLOW BEARING GUARD" STICKER INCLUDED"
21	28-50-0225	1	BELT-TIGHTENER
22	12-44-0015	1	RED SPRING 1 1/2" OD 1" ID X 8 1/2"
23	28-42-0155	2	SPRING GUIDE
24	NC02-22-0013	1	WASHER ZINC 5/8 ID X 1 1/2 OD
25	28-50-0145	1	TIGHTENER STOPPER NUT
26	NC02-14-0304	1	HEX. NUT CHÂTEAU 5/8-11 NC ZINC
27	28-42-0110	1	FLAT WASHER 1 1/4" DIA.
28	NC01-69-0423	2	SPRING PIN 3/16" X 1 1/4"
29	29-46-3765	1	GASKET

AGRIMETAL

(OPT.) 6' COMPLETE PICK-UP HEAD VERTI-CUT

CREATION : 23/08/17
REVISION : 16/09/21

ASSEMBLY : **29-55-0036**
AUTHOR : J.KABWE

#	PART #	Qty	TITLE
1	29-55-0031	1	6' VERTI-CUT ROTARY ROTOR ONLY
2	28-50-0305	2	BEARING GUARD AND REINFORCEMENT
3	NC14-75-0024	2	FLANGE BEARING 4 HOLES UCF207-20 1 1/4" DIA.
4	NC01-04-0236	8	CARR. BOLT GR2 NC ZINC 1/2-13 1 3/4"
5	NC02-32-0014	8	LOCK WASHER ZINC 1/2"
6	12-01-3051	1	REAR BEARING PROTECTOR
7	NC02-07-0020	8	HEX. NUT ZINC 1/2-13
8	NC14-62-0223	1	CAS IRON SHAVE PULLEY 3B60 SD
9	NC14-62-0005	1	QD BUSHING SD 1 1/4"
10	NC01-65-0087	1	KEY 1/4 X 1/4 X 1 1/2"
11	NC14-25-3376	1	V BELT 3RB-63 21/32

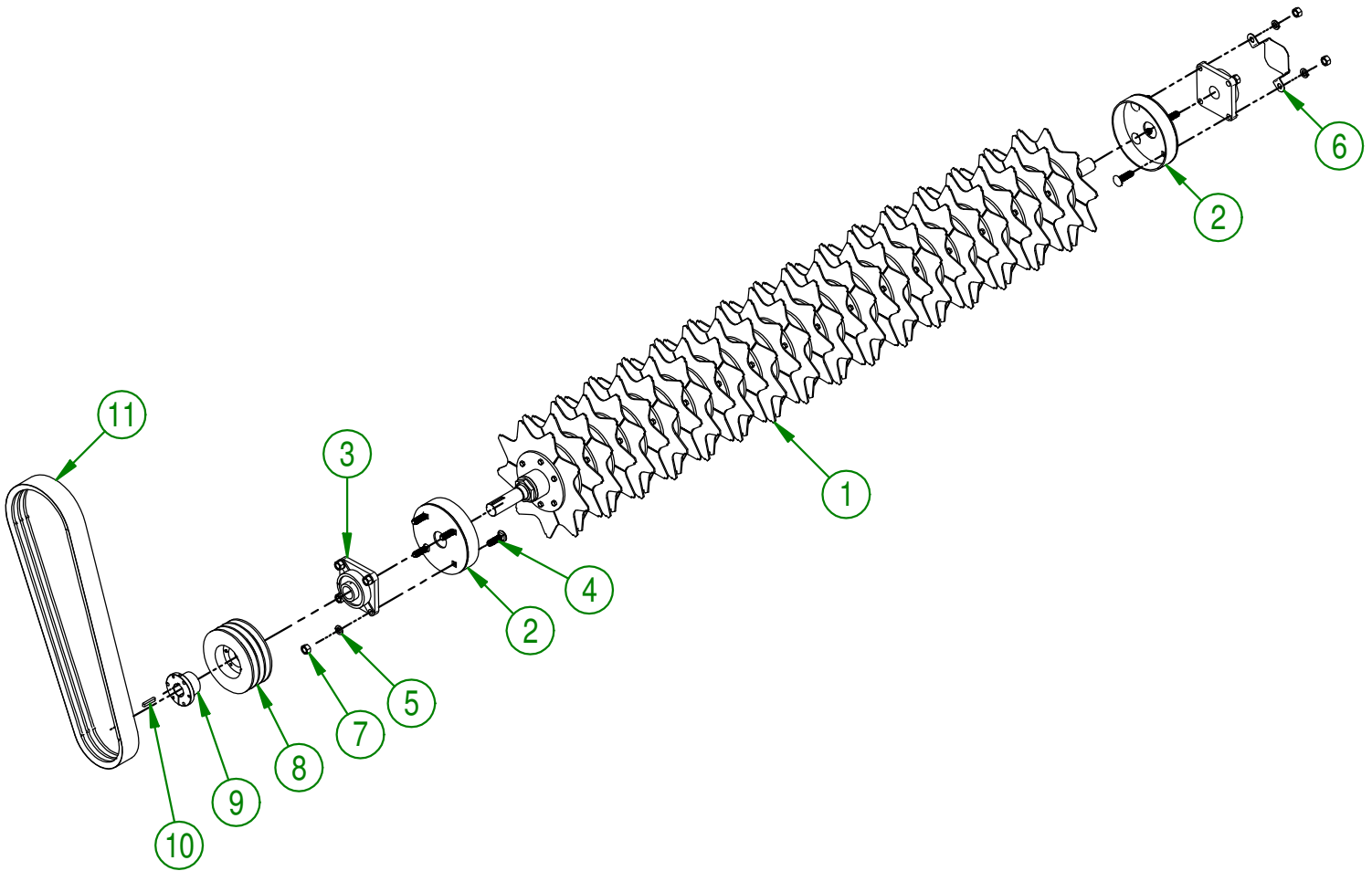

AGRIMETAL	
(OPT.) 6' RIGID DISC ROTOR GROUP. (VERTICUT)	
CREATION : 23/08/17	ASSEMBLY : 29-57-0195
REVISION : 26/01/18	AUTHOR : J.KABWE Page 66 de 72

#	PART #	Qty	TITLE
1	29-25-2405	1	ROTOR VERTICUT SHAFT
2	29-13-3600	2	ROTOR WASHER
3	NC01-98-0022	2	NYLON NUT HEX. I 3/8-12 THIN
4	29-09-1100	33	BLADE SPACER
5	29-55-0055	32	VERTI-TATCH KNIFE

#	PART #	Qty	TITLE
6	29-04-0305	2	KNIFE HOLDER
7	150-01-0110	1	SPACER
8	NC13-22-0025	1	VERTICUT KNIFE
9	NC01-17-0006	6	HEX. BOLT 1/4-20 X 1"
10	NC01-96-0009	6	NYLON-INSERT LOCKNUT ZINC 1/4-20

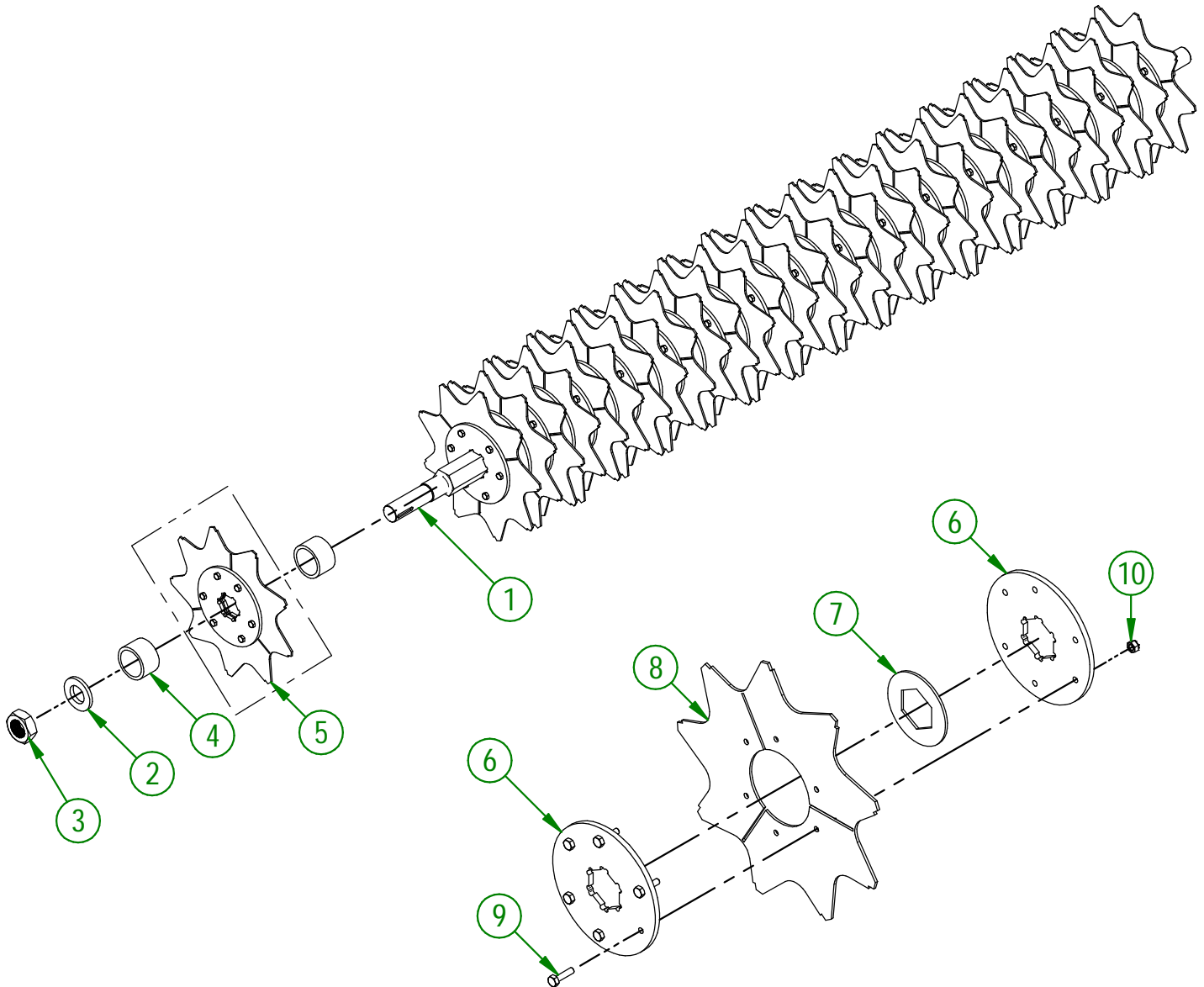

AGRIMETAL	
(OPT.) 6' VERTI-CUT ROTARY ROTOR ONLY	
CREATION : 23/08/17	ASSEMBLY : 29-55-0031
REVISION : 11/10/23	AUTHOR : J.KABWE

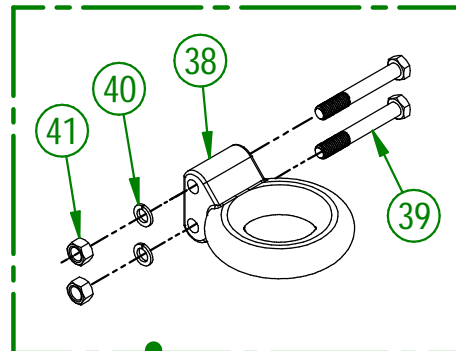
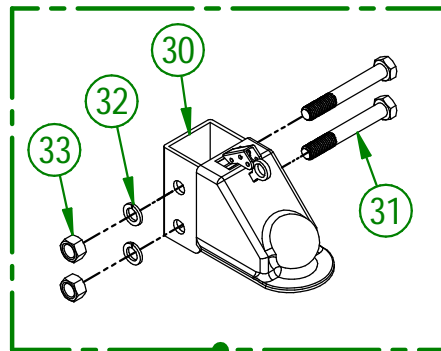
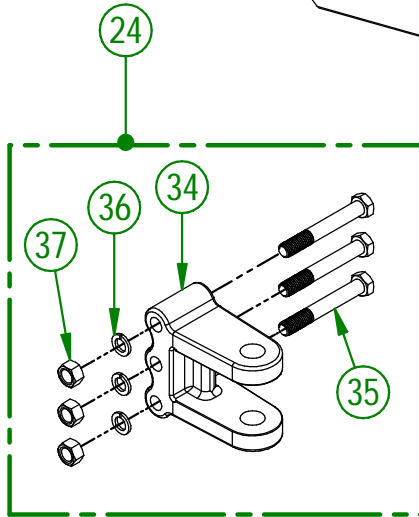
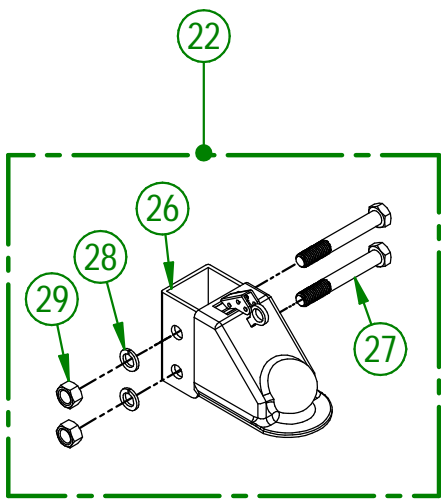
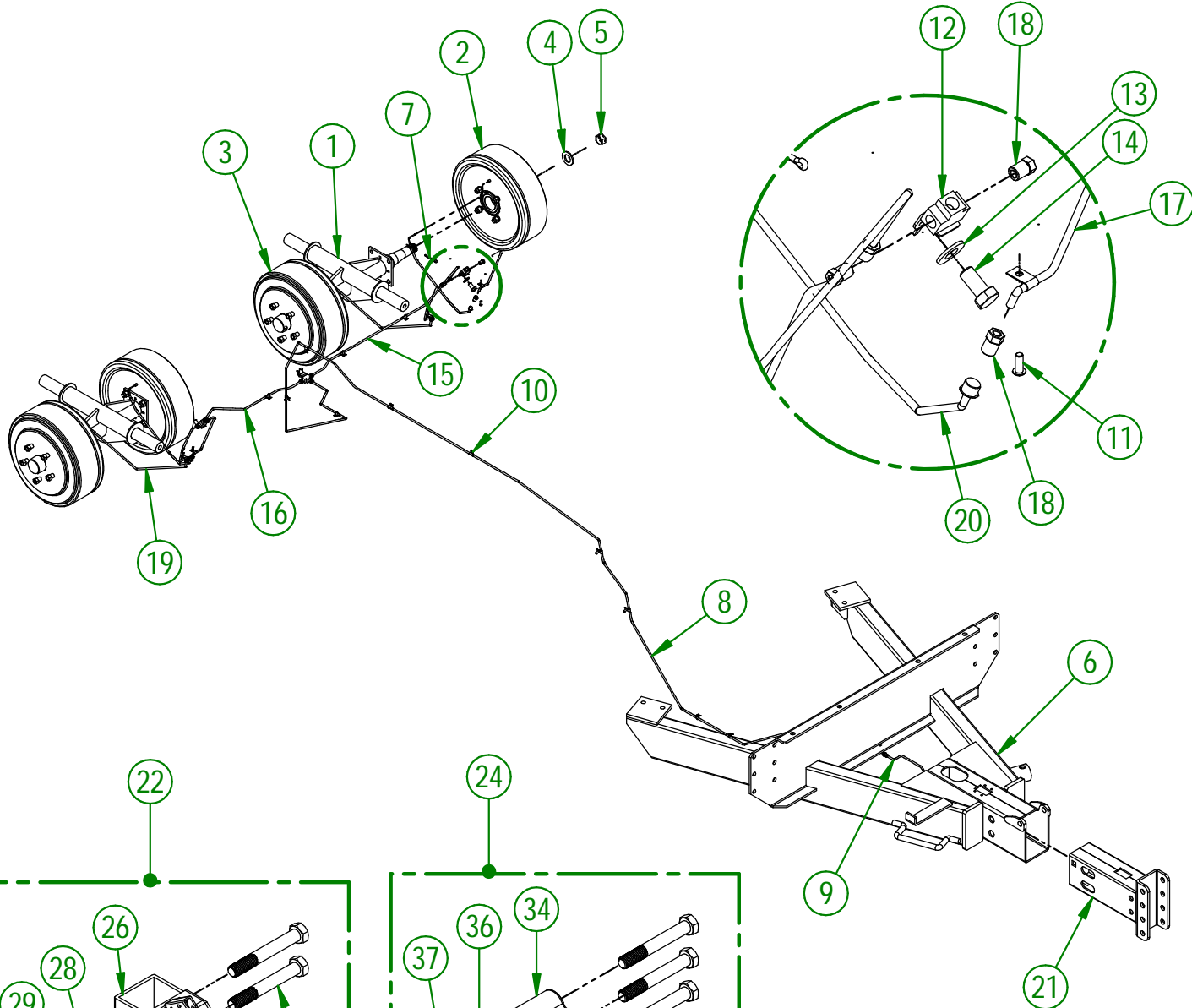

AGRIMETAL
HYDRAULIC BRAKE GROUP.

CREATION : 14/03/18
 REVISION : 08/03/23

ASSEMBLY : **29-57-0185**
 AUTHOR : J.KABWE

#	PART #	QTY	TITLE
1	28-50-0143	2	AXLE (HYDRAULIC BRAKE)
2	NC14-70-0627	2	BRAKE 8 1/2" X 2 1/4" FREE LH (2XKIT MV)
3	NC14-70-0626	2	BRAKE 8 1/2" X 2 1/4" FREE RH (2XKIT MV)
4	NC14-70-0632	4	SPACER
5	NC14-70-0633	4	HEX. NUT CHÂTEAU 1"-14 NC ZINC
6	29-50-0125	1	DRAW BAR (OPTION)
7	NC14-70-0603	4	G6 COTTER PIN 5/32" X 2"
8	29-46-0010	1	RIGID HOSE 3/16" X 150"
9	NC14-70-0624	1	FLEXIBLE HOSE BRAKE MF 18"
10	NC13-25-0391	18	LOOP CLAMPS
11	NC02-40-0082	18	MACHINE SCREW PHILLIPS ZINC 10-24 OU 3/16"
12	NC14-70-0630	3	T UNION 3/16" WITH BRACKET (3XKIT MV)
13	01-01-2485	3	FLAT WASHER 14 GA X 13/16"OD X 25/64" ID
14	NC01-17-0112	3	HEX. BOLT GR2 ZINC 3/8-16 X 3/4"
15	29-46-0015	1	RIGID HOSE 3/16" X 35"
16	29-46-0020	1	RIGID HOSE 3/16" X 16"
17	29-46-0025	4	RIGID HOSE 3/16" X 12"
18	NC14-70-0623	14	BOLT FOR RIGID HOSE 3/16"
19	NC14-70-0631	2	FLEXIBLE HOSE 18" 90 TORFLEX (4X KIT MV)
20	NC14-70-0631	2	FLEXIBLE HOSE 18" 90 TORFLEX (4XKIT MV)
21	NC14-70-0612	1	BRAKE ADJUSTABLE ACTIVATOR 10000 LBS
22	22-57-0700	1	MAIN AJUSTABLE BOULE 2 5/16"
23	22-57-0705	1	MAIN AJUSTABLE BOULE 2"
24	22-57-0710	1	CLEVIS 1" AJUSTABLE
25	22-57-0715	1	ANNEAU 3" AJUSTABLE

22-57-0700

#	PART #	QTY	TITLE
26	NC14-70-0602	1	ADJUSTABLE 2-5/16" BALL COUPLER (2 HOLES)
27	NC01-33-0406	2	HEX. BOLT GR8 ZINC 5/8-11 X 4 1/2" LG
28	NC02-32-0016	2	LOCK WASHER ZINC 5/8"
29	NC02-07-0022	2	HEX. NUT ZINC 5/8-11

22-57-0705

#	PART #	QTY	TITLE
30	NC14-70-0620	1	ADJUSTABLE 2" BALL COUPLER
31	NC01-33-0406	2	HEX. BOLT GR8 ZINC 5/8-11 X 4 1/2" LG
32	NC02-32-0016	2	LOCK WASHER ZINC 5/8"
33	NC02-07-0022	2	HEX. NUT ZINC 5/8-11

22-57-0710

#	PART #	QTY	TITLE
34	NC13-80-0241	1	ADJUSTABLE 1" CLEVIS (3 HOLES)
35	NC01-33-0406	3	HEX. BOLT GR8 ZINC 5/8-11 X 4 1/2" LG
36	NC02-32-0016	3	LOCK WASHER ZINC 5/8"
37	NC02-07-0022	3	HEX. NUT ZINC 5/8-11

22-57-0715

#	PART #	QTY	TITLE
38	NC14-70-0601	1	ADJUSTABLE 3" LUNETTE RING (2 HOLES)
39	NC01-33-0406	2	HEX. BOLT GR8 ZINC 5/8-11 X 4 1/2" LG
40	NC02-32-0016	2	LOCK WASHER ZINC 5/8"
41	NC02-07-0022	2	HEX. NUT ZINC 5/8-11

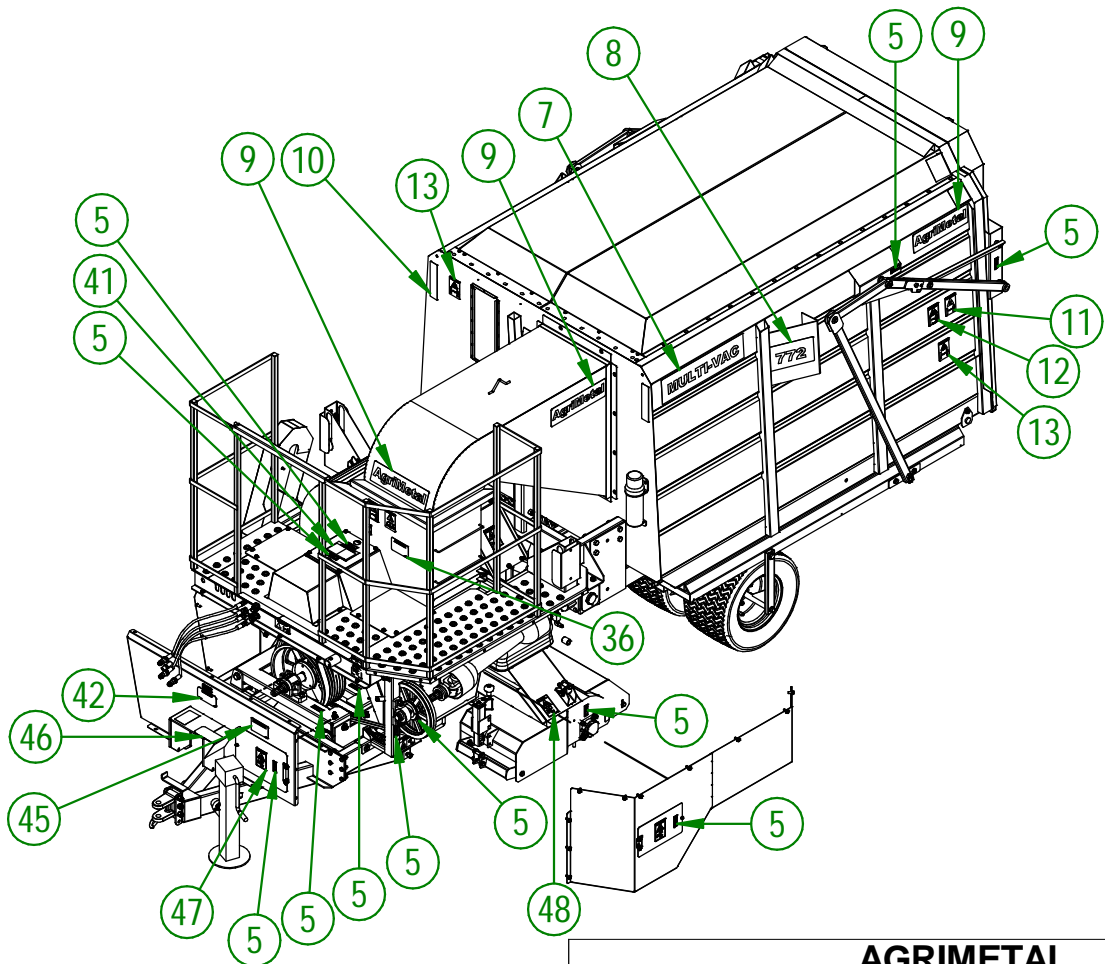
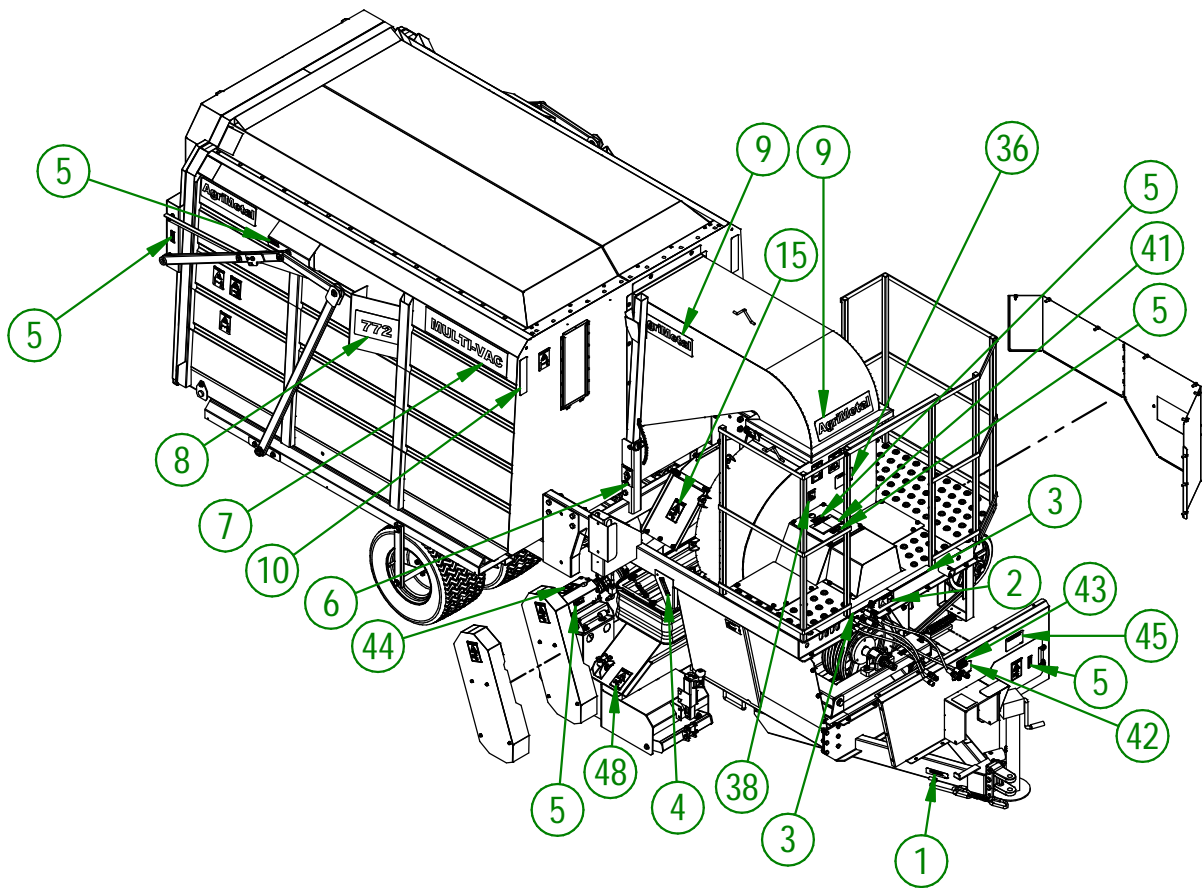

AGRIMETAL	
MULTI-VAC 772 PTO (RUBBER FINGER)	
CREATION : 27/11/17	ASSEMBLY : 29-99-0000
REVISION : 23/05/24	AUTHOR : J.KABWE

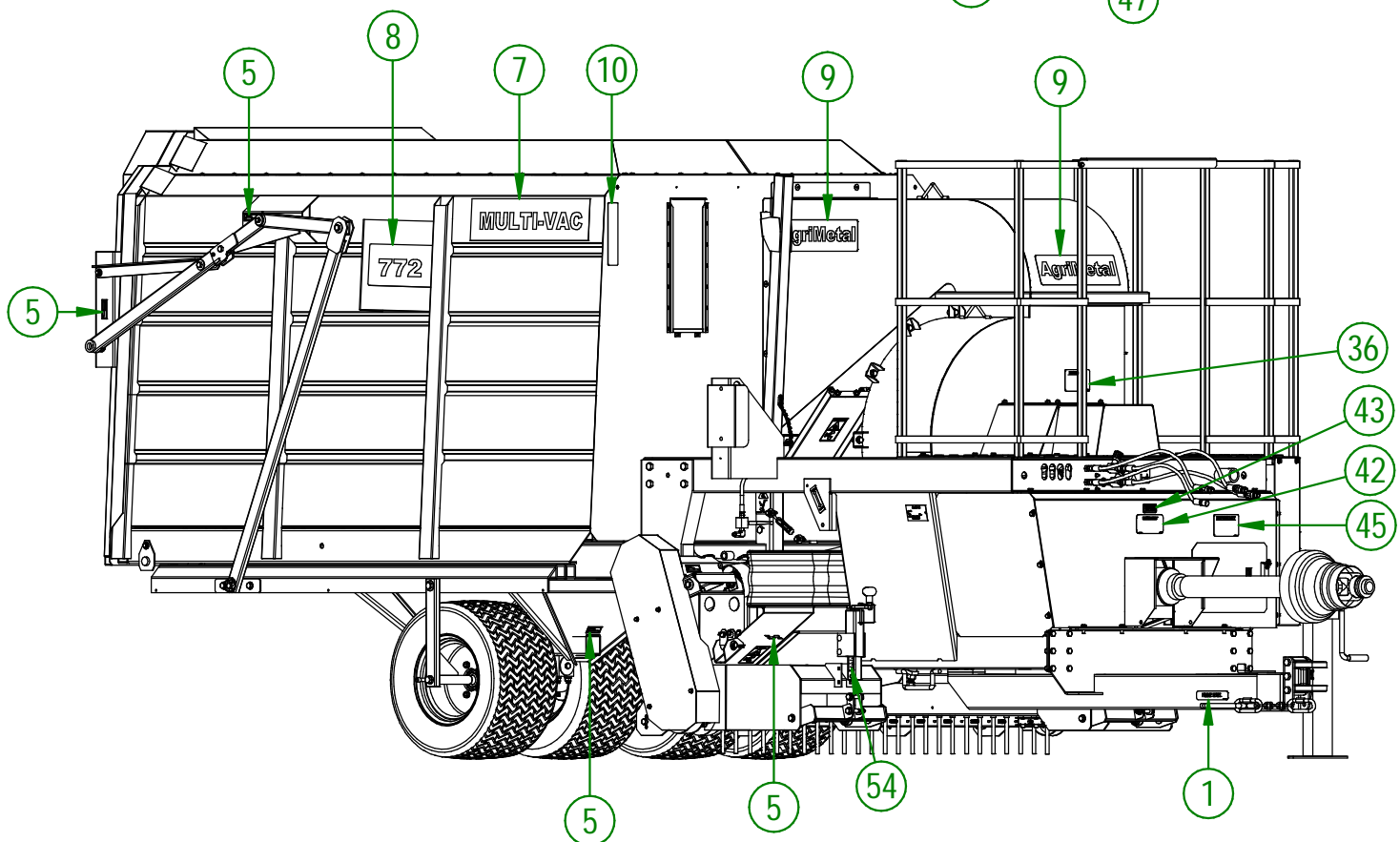
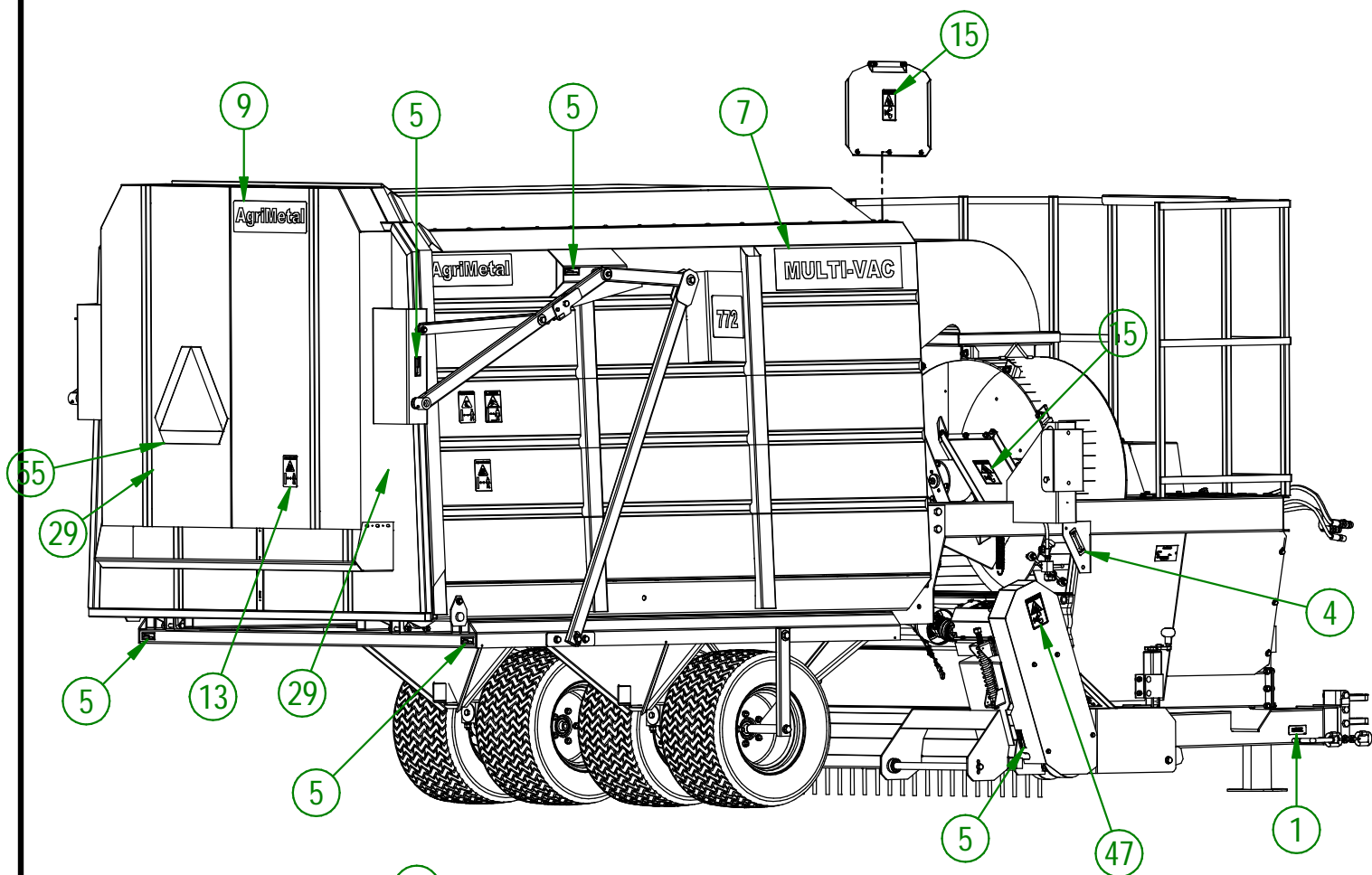

AGRIMETAL	
MULTI-VAC 772 PTO (RUBBER FINGER)	
CREATION : 27/11/17	ASSEMBLY : 29-99-0000
REVISION : 23/05/24	AUTHOR : J.KABWE

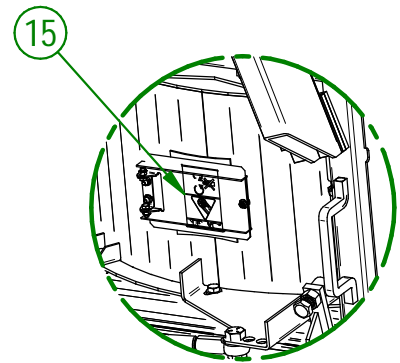
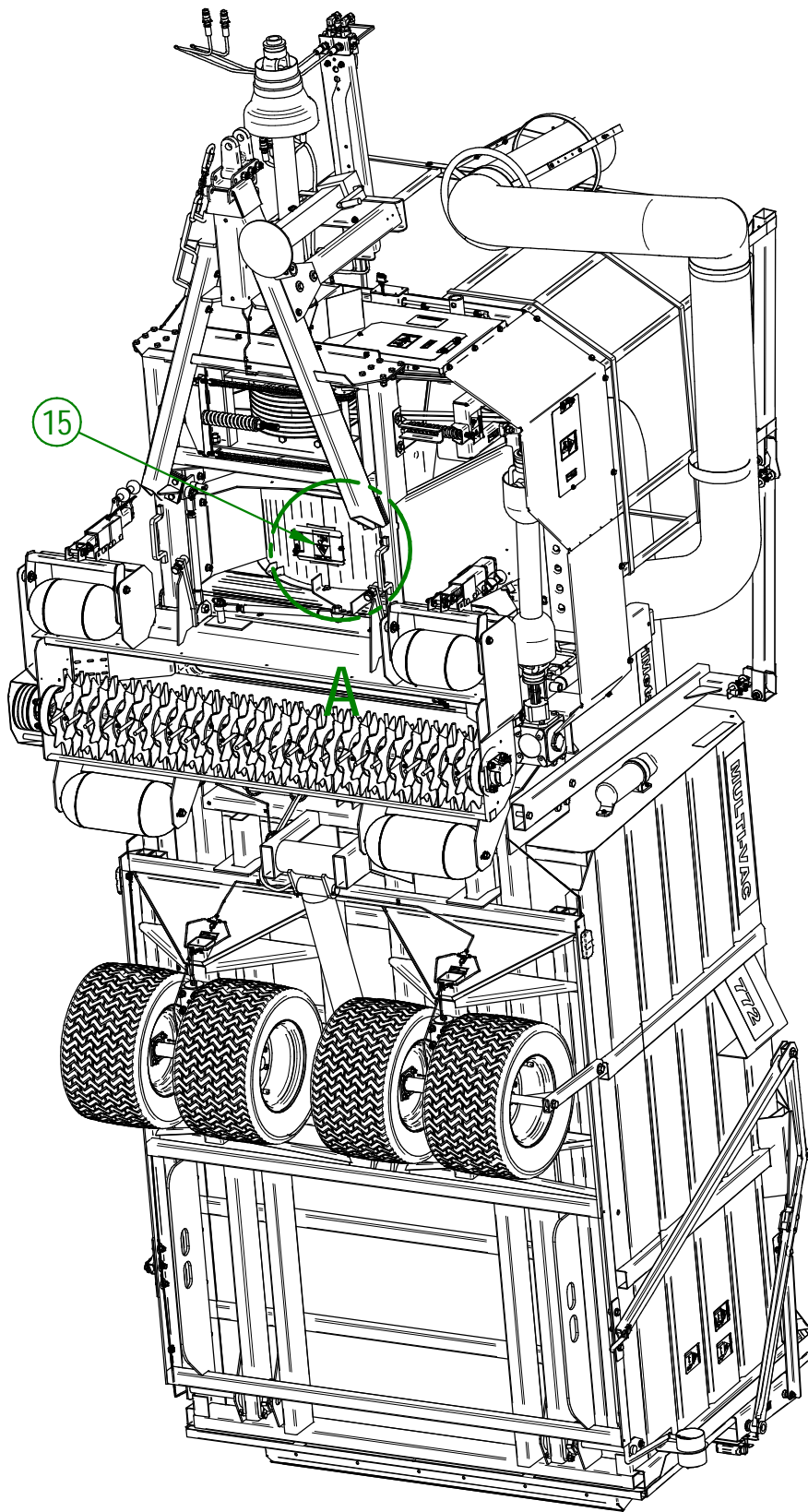

DETAIL A

AGRIMETAL	
MULTI-VAC 772 PTO (RUBBER FINGER)	
CREATION : 27/11/17	ASSEMBLY : 29-99-0000
REVISION : 23/05/24	AUTHOR : J.KABWE

#	# DE PIÈCE	QTÉ	TITRE
1	NC13-33-0052	2	STICKER FRAME LEVEL
2	NC13-33-0288	1	STICKER WARNING HIGH-PRESSURE LIQUID
3	NC13-80-0081	3	STICKER ANTI-SLIP ROUND CORNER BLACK 1 1/2" X 12"
4	NC13-33-0119	1	STICKER HEAD HOSE
5	NC13-33-0024	23	STICKER GREASE HERE
6	NC13-33-0261	1	STICKER WARNING
7	NC13-33-0165	2	STICKER MULTI-VAC 6" X 24"
8	NC13-33-0164	2	STICKER FOR MULTI-VAC 6" X 10" (772)
9	NC13-33-0001	6	STICKER AGRIMETAL
10	NC13-33-0170	2	STICKER SCOTCHLITE BAND 2" X 9"
11	NC13-33-0268	2	STICKER WARNING
12	NC13-33-0260	2	STICKER WARNING
13	NC13-33-0192	4	STICKER (PROJECTION RISK)
15	NC13-33-0186	5	STICKER (DANGER)
34	NC01-69-0427	2	SPRING TIGHTENER PIN ZINC 3/16 X 1 1/2"
35	NC13-33-0290	1	STICKER DANGER
36	NC13-33-0176	1	STICKER IMPORTANT
37	NC13-33-0282	3	STICKER DANGER
38	NC13-33-0305	1	STICKER 75 dB
39	NC13-33-0183	1	STICKER CAUTION OPERATION MANUAL
40	NC13-33-0259	1	STICKER DANGER ELECTRIC LIGNE
41	NC13-33-0181	1	STICKER IMPORTANT GREASE PERIODICALLY THE TWO BEARING
42	NC13-33-0072	1	STICKER IMPORTANT ADJUST TRACTOR AND/OR PTO SHAFT LENGTH
43	NC13-33-0005	1	STICKER MAXIMUM 540 RPM
44	NC13-33-0187	3	STICKER DANGER (PTO AND PERSON)
45	NC13-33-0179	1	STICKER IMPORTANT GREASE DRIVE LINE
46	NC13-80-0082	1	STICKER ANTI-SCRATCH 3" X 6"
47	NC13-33-0287	4	STICKER WARNING
48	NC13-33-0190	4	STICKER WARNING ROTATING BLADE HAZARD
54	NC13-33-0155	4	STICKER RULES 3"
55	NC13-33-0102	1	STICKER TRIANGLE FOR SLOW MACHINERY
56	16-60-0050	2	STICKER RED SCOTCHLITE 2" HIGH X 9" LENGTH

AGRIMETAL

MULTI-VAC 772 PTO (RUBBER FINGER)

CREATION : 27/11/17
REVISION : 23/05/24

ASSEMBLY : **29-99-0000**
AUTHOR : J.KABWE