

# AgriMetal

## PARTS LIST

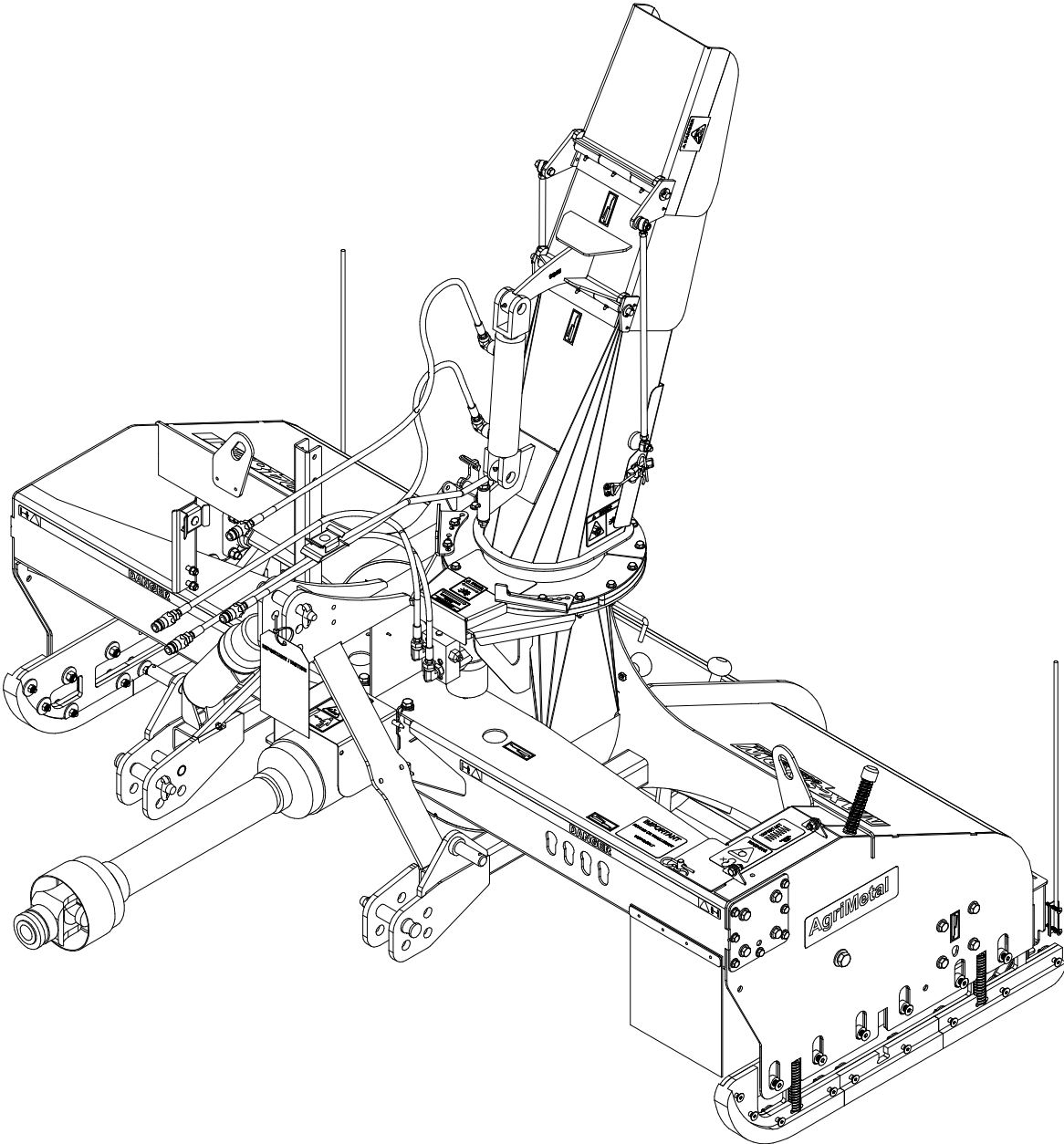

**MS 2482-i**

#	PART #	Qty	TITLE
1	NC13-15-0317	1	CENTER KNIFE (RUBBER)
2	84-42-0001	1	LEFT KNIFE (RUBBER)
3	84-42-0000	1	RIGHT KNIFE (RUBBER)
4	91-20-0150	17	WASHER
5	NC01-96-0014	17	NYLON INSERT LOCKNUT 1/2-13"
6	NC01-54-1252	17	HEX BOLT. GR2 STAINLESS 1/2-13 X 2 1/4"
7	84-04-0050	1	LEFT KNIFE BRACE
8	84-04-0052	1	RIGHT KNIFE BRACE

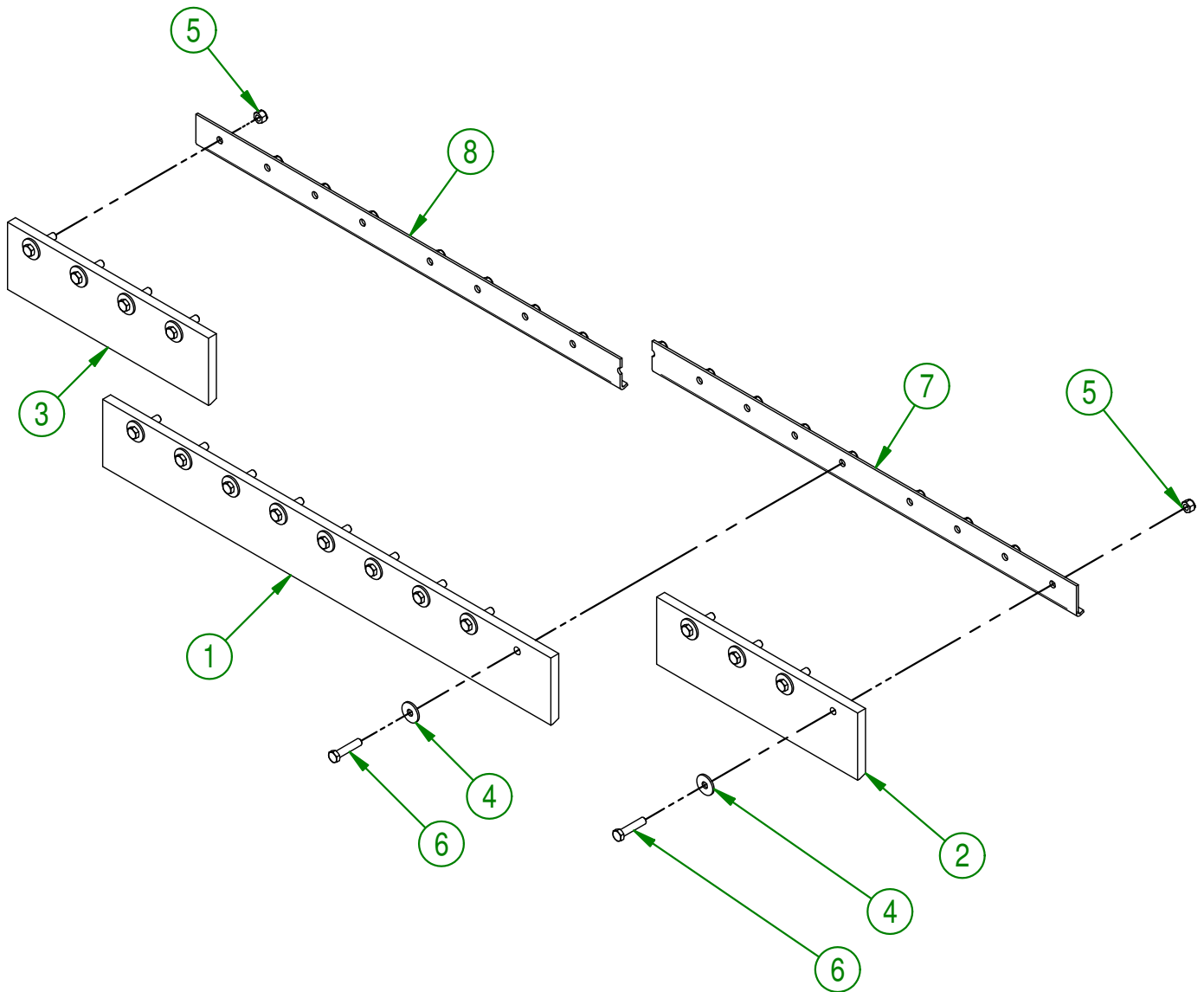

**AGRIMETAL**  
**RUBBER BLADES KIT**

CREATION : 05/12/17  
 REVISION : 05/03/19

ASSEMBLY : **84-57-0005**

AUTHOR : F.HÉLIE

Page 1 de 19

#	PART #	Qty	TITLE
1	84-42-0160	1	CENTER KNIFE (UHMW)
2	84-42-0165	2	KNIFE (UHMW)
3	91-20-0150	17	WASHER
4	NC01-96-0014	17	NYLON INSERT LOCKNUT 1/2-13"
5	NC01-54-1252	17	HEX BOLT. GR2 STAINLESS 1/2-13 X 2 1/4"
6	84-04-0050	1	LEFT KNIFE BRACE
7	84-04-0052	1	RIGHT KNIFE BRACE

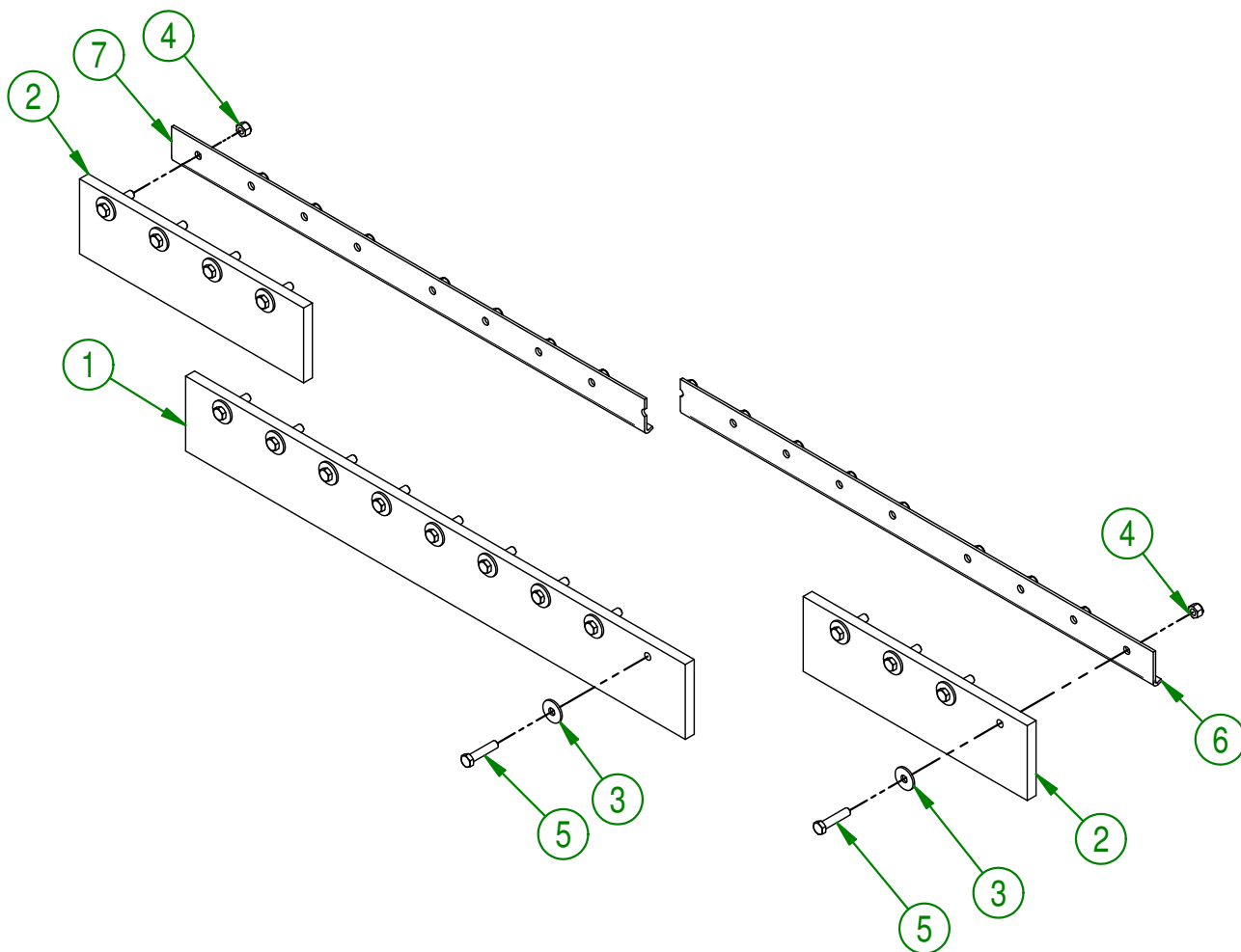

<b>AGRIMETAL</b>	
UHMW BLADES KIT (OPTION)	
CREATION : 05/12/17	ASSEMBLY : <b>84-57-0010</b>
REVISION : 05/03/19	AUTHOR : F.HÉLIE   Page 2 de 19

84-57-9005

#	PART #	Qty	TITLE
1	84-04-0927	2	KNIFE SUPPORT BRACE (CONVERSION)
2	84-20-0120	1	KNIFE BRACE
3	NC01-25-0250	17	HEX.BOLT GR5 NC ZINC 1/2-13 X 1 3/4"
4	84-50-9010	1	KNIFE SUPPORT (CONVERSION)
5	NC01-09-0033	12	PLOW BOLT GR5 1/2-13 X 2" LG
6	NC01-93-0014	29	LOCK NUT ZINC 1/2-13
7	84-04-0542	1	RUBBER KNIFE BRACE
8	NC02-48-0109	13	FLAT SOCKET CAP SCREWS 1/2-20 X 1 1/4" GRADE 8
9	84-42-0100	1	RIGHT KNIFE (RUBBER) MS24-i
10	84-42-0105	1	LEFT KNIFE (RUBBER) MS24-i

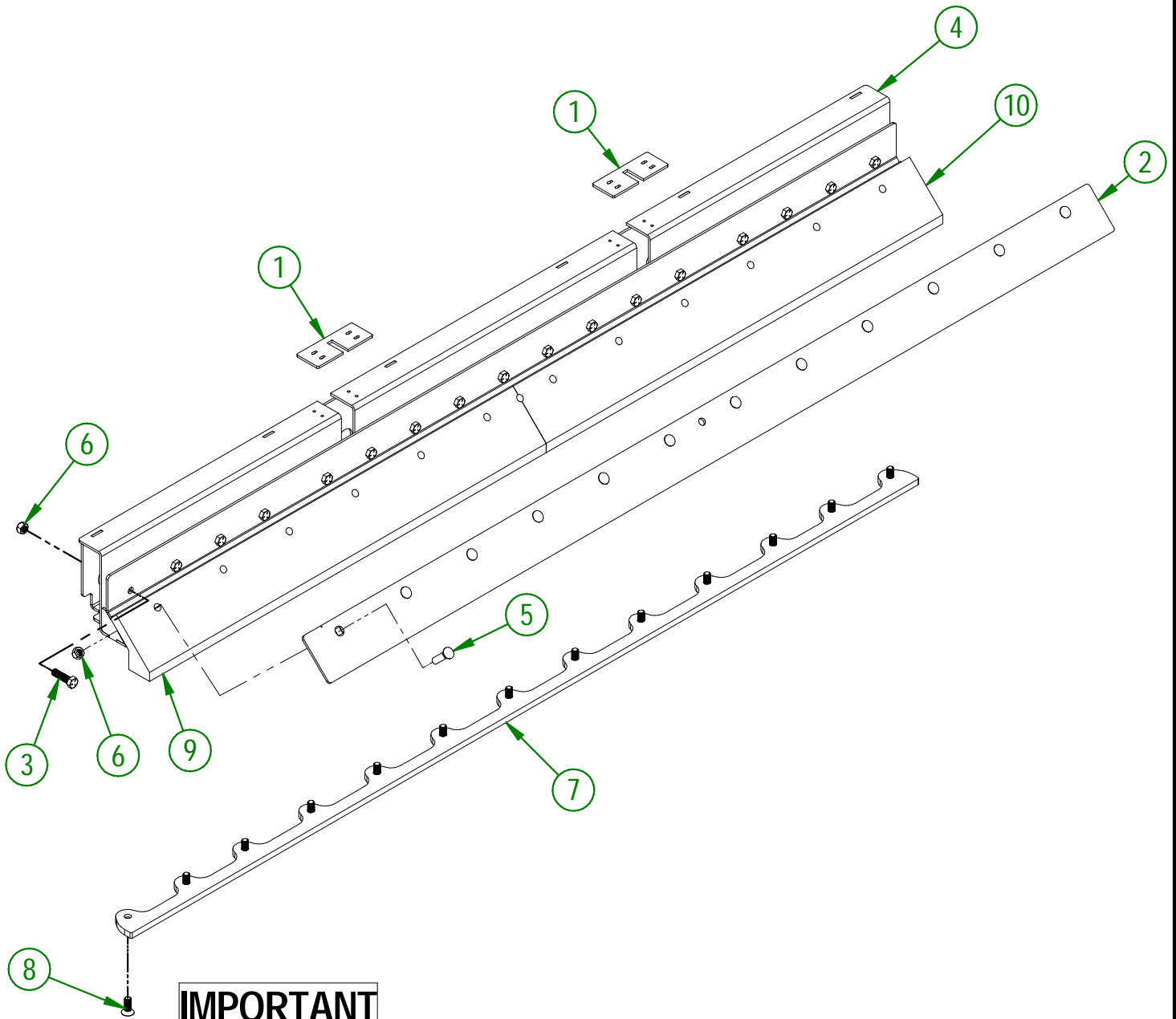

**IMPORTANT**

USE THIS PARTS ONLY IF YOUR SERIAL NUMBER IS INVOLVED:

#36421 AND LESS

**AGRIMETAL**  
CONVERSION KIT (45° KNIFE)

CREATION : 07/11/18  
REVISION : 13/12/23

ASSEMBLY : **84-57-9005**  
AUTHOR : F.HÉLIE

84-57-1315

#	PART #	Qty	TITLE
1	84-50-1310	1	PTO SUPPORT
2	01-01-2485	2	FLAT WASHER
3	NC02-32-0012	2	LOCK WASHER ZINC 3/8"
4	NC02-07-0018	2	HEX. NUT ZINC 3/8-16

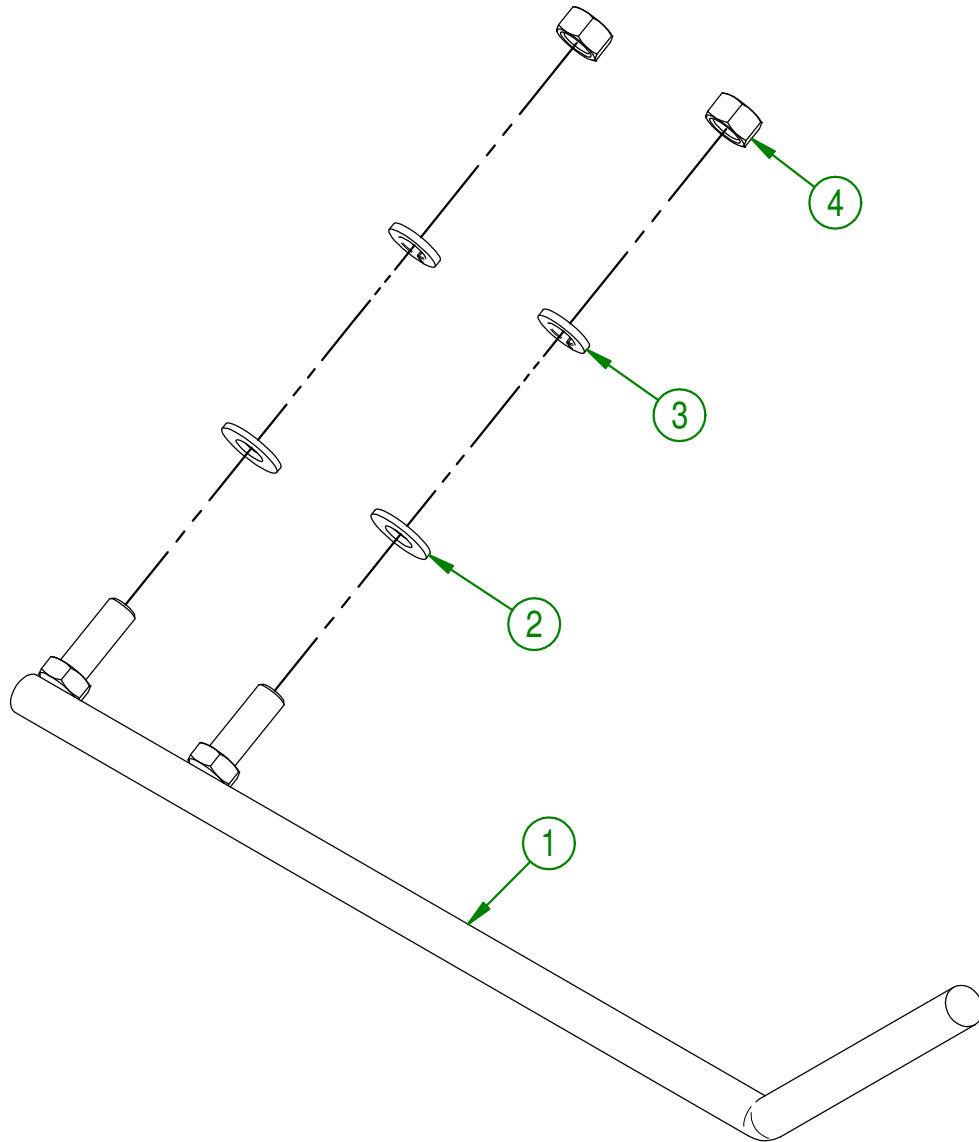

<b>AGRIMETAL</b>	
PTO SUPPORT GROUP (OPTION)	
CREATION : 06/12/17	ASSEMBLY : <b>84-57-1315</b>
REVISION : 03/01/18	AUTHOR : J.KABWE   Page 4 de 19

#	PART #	Qty	TITLE
1	NC01-93-0014	21	LOCK NUT ZINC 1/2-13
2	91-20-0150	39	WASHER
3	NC01-54-1251	15	HEX BOLT.GR2 STAINLESS 1/2-13 X 2"
4	NC01-54-1257	4	HEX BOLT. GR2 STAINLESS 1/2-13 X 3 1/2"
5	NC02-48-0547	2	FLAT HEAD SOCKET CAP SCREW STAINLESS 1/2-13 X 1 3/4
6	84-42-0130	2	FLOATING SKATE
7	NC02-48-0546	2	HEX DRIVE FLAT HEAD STAINLESS 1/2-13 X 1 1/2"
8	84-42-0147	1	FIXED SABOT (RIGHT)
9	NC01-96-0014	8	NYLON-INSERT LOCKNUT ZINC 1/2-13
10	NC01-54-1253	8	HEX BOLT. GR2 STAINLESS 1/2-13 X 2 1/2"
11	84-13-1400	8	FLOATING SKATE BUSHING
12	NC13-15-0318	1	EXTERIOR RUBBER KNIFE
13	84-42-0063	1	RIGHT KNIFE (VERSION I)
14	84-42-0060	1	LEFT KNIFE (VERSION I)
15	84-42-0065	1	RIGHT KNIFE DOUBLING (VERSION I)
16	84-42-0067	1	LEFT KNIFE DOUBLING (VERSION I)
17	84-42-0145	1	FIXED SABOT (LEFT)
18	NC13-85-0057	2	TENSIONER ROD
19	01-33-0010	10	WASHER
20	NC01-96-0011	4	NYLON NUT 3/8-16
21	NC01-17-0117	4	HEX. BOLT GR2 ZINC 3/8-16 X 1 3/4"

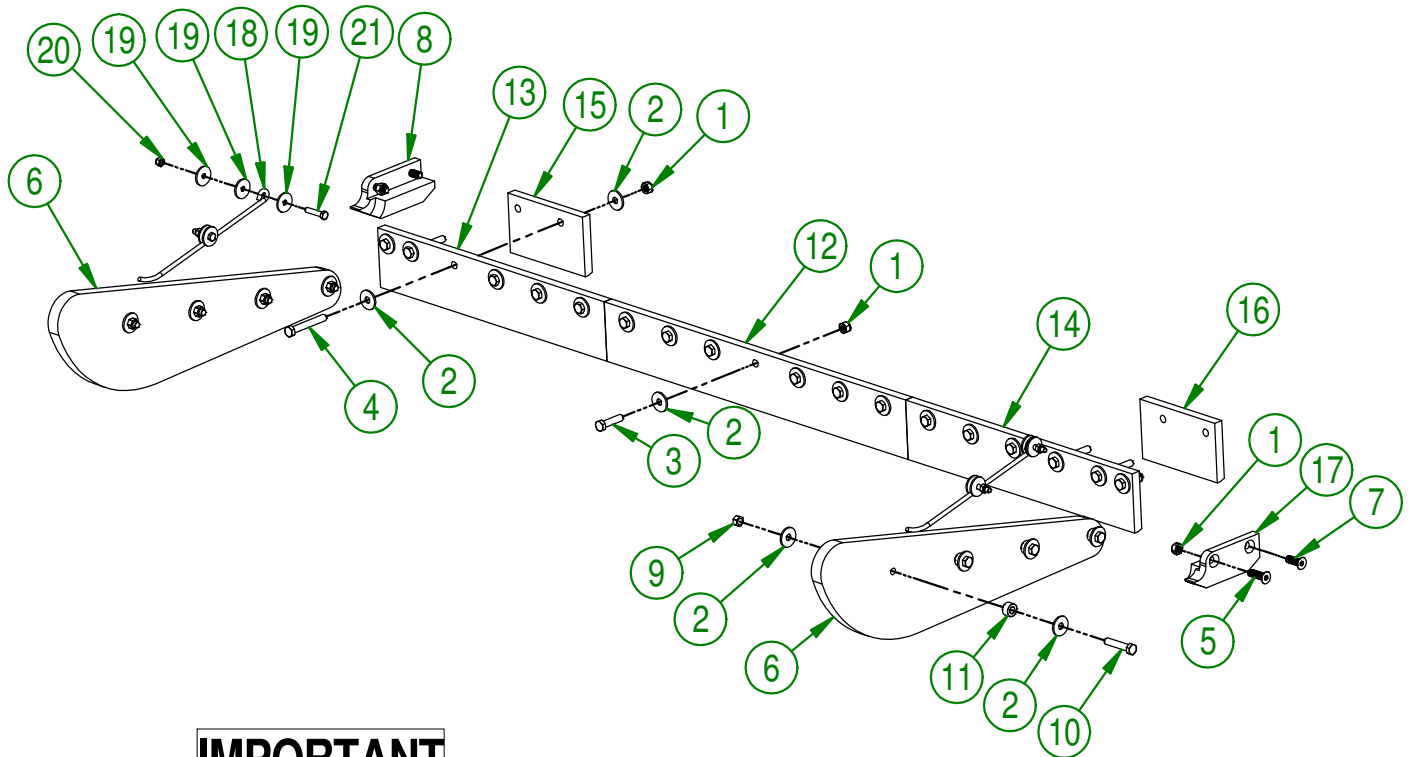

### IMPORTANT

USE THIS PARTS ONLY IF YOUR SERIAL NUMBER IS INVOLVED:

#35574 TO 35580

### AGRIMETAL FLOATING SKATE

CREATION : 20/12/17  
REVISION : 22/01/19

ASSEMBLY : **84-57-0040**

AUTHOR : F.HÉLIE

Page 5 de 19

#	PART #	Qty	TITLE
1	91-42-0138	2	FLOATING SKATE (MIDDLE FRONT)
2	91-42-0150	2	FLOATING SKATE (MIDDLE BACK)
3	84-04-1100	1	FLOATING SKATE (INSIDE LEFT)
4	84-42-0010	2	FLOATING SKATE (MIDDLE)
5	NC01-96-0014	12	NYLON INSERT LOCKNUT 1/2-13"
6	NC02-48-0548	12	FLAT HEAD SOCKET CAP SCREW STAINLESS 1/2-13 X 2"
7	NC02-48-0535	18	STAINLESS FLAT HEAD SOCKET CAP SREW 3/8-16 X 1 3/4
8	NC01-96-0011	18	NYLON NUT 3/8-16
9	84-04-1105	1	FLOATING SKATE (INSIDE RIGHT)
10	91-09-0000	12	BUSHING
11	NC13-86-0052	4	SPRING 1/2" ID X 1" OD X 5" LG
12	39-01-2440	2	GUIDE ROD CLAMP
13	NC01-96-0009	4	NYLON-INSERT LOCKNUT ZINC 1/4-20
14	39-42-0600	2	GUIDE ROD
15	NC02-48-0513	4	HEX DRIVE FLAT HEAD SCREW 1/4-20 X 1 1/2"
16	84-04-1115	1	FLOATING SKATE (OUTSIDE RIGHT)
17	84-04-1110	1	FLOATING SKATE (OUTSIDE LEFT)

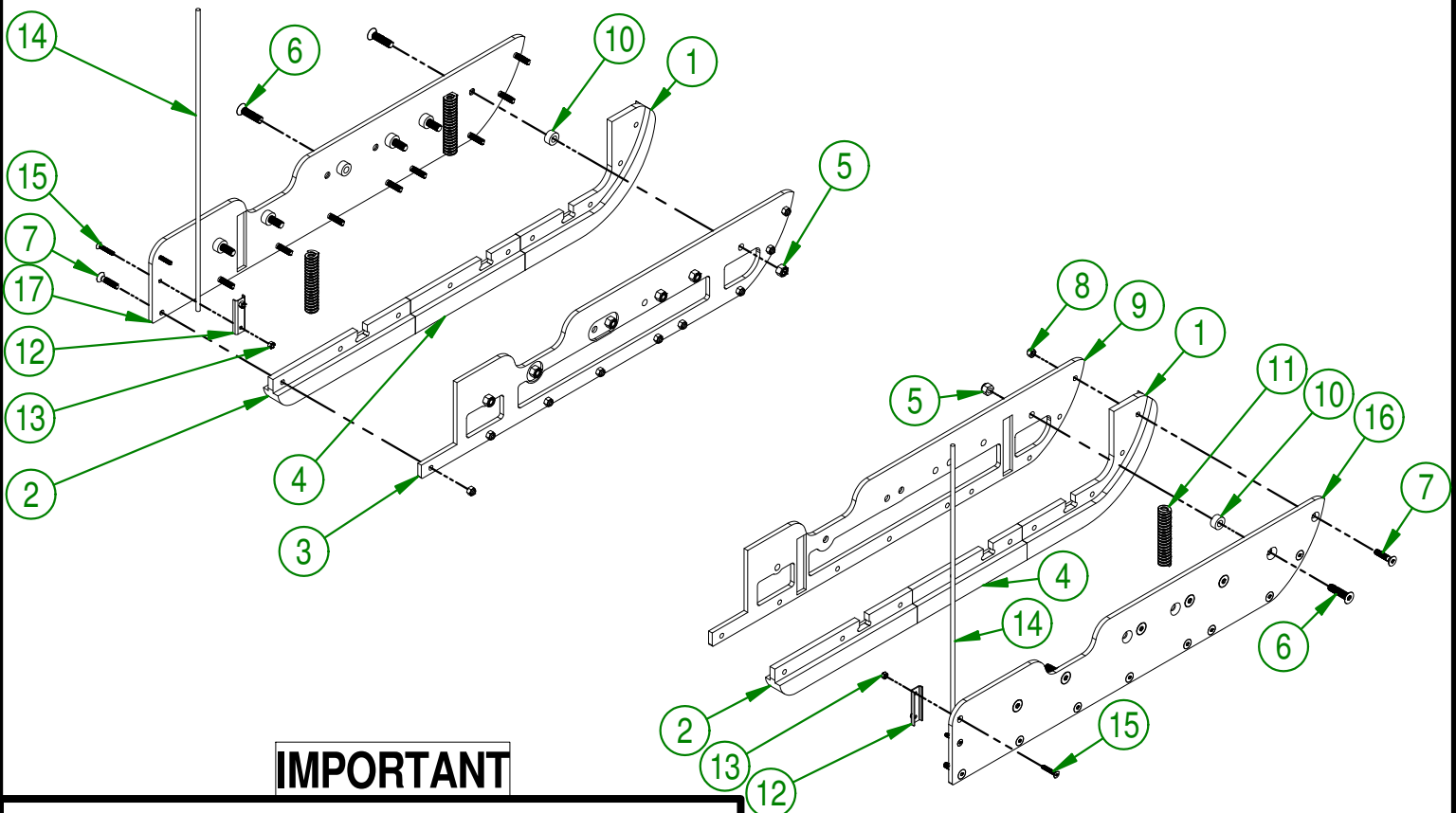
**IMPORTANT**

USE THIS PARTS ONLY IF YOUR SERIAL NUMBER IS INVOLVED:

#36245 TO 36421

**AGRIMETAL**  
FLOATING SKATE GROUP

CREATION : 19/12/17  
REVISION : 11/02/19

ASSEMBLY : **84-57-0050**

AUTHOR : F.HÉLIE

Page 6 de 19

84-57-0066

#	PART #	Qty	TITLE
1	48-20-0075	1	3 POINT PIN
2	48-20-0070	2	3 POINT PIN
3	NC01-69-1100	3	LINCH PIN 3/8"
4	82-13-1300	2	HITCH CONVERSION BUSHING (CATEGORY 2)
5	82-09-1210	1	HITCH CONVERSION BUSHING (CATEGORY 2)
6	NC01-63-0026	1	COTTER PIN ZC 5/32" X 3"
7	84-50-0090	1	STAND
8	NC01-69-1306	1	LOCKING PIN 3/8" X 2 1/2" LG
9	NC13-15-0315	1	SNOW GUARD
10	82-01-0970	1	SNOW GUARD BRACE
11	NC01-78-0041	4	POP RIVET STAINLESS STEEL ROD STEEL .187" X .690"
12	84-57-0001	1	FRAME

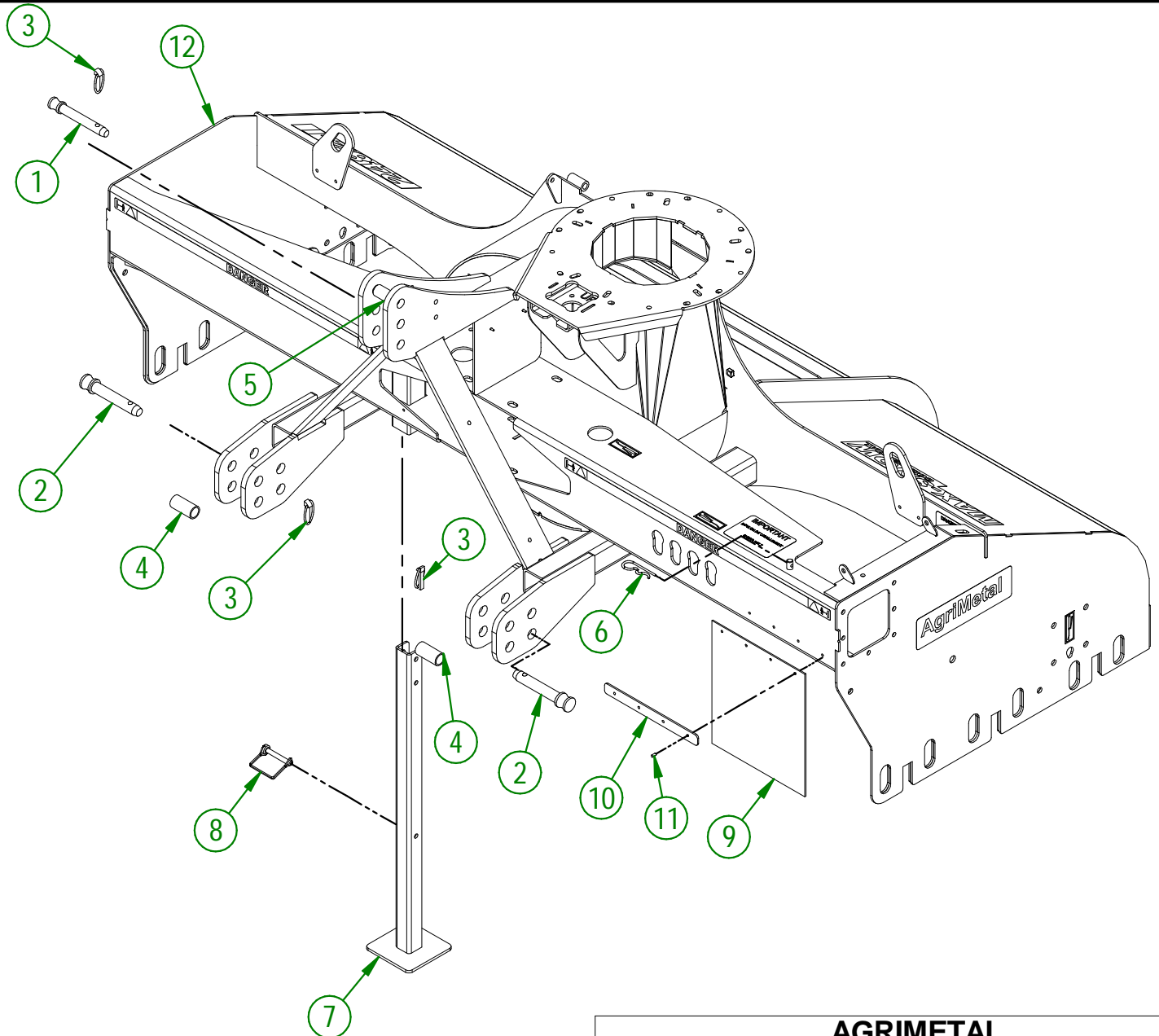

**AGRIMETAL**  
**FRAME GROUP**

CREATION : 05/12/17  
REVISION : 06/01/26

ASSEMBLY : **84-57-0066**  
AUTHOR : F.HÉLIE

#	PART #	Qty	TITLE
1	NC01-17-0255	2	HEX. BOLT GR2 ZINC 1/2-13 X 3"
2	NC01-96-0014	2	NYLON-INSERT LOCKNUT ZINC 1/2-13
3	NC17-46-0018	4	HANDLE KNOB
4	NC01-17-0119	4	HEX. BOLT GR2 ZINC 3/8-16 X 2 1/4"
5	84-57-0075	1	IMPELLER ACCESS DOOR
6	NC01-69-1100	1	LINCH PIN 3/8"
7	NC02-26-1525	4	WASHER INOX .406" D.I. X .815" D.E.

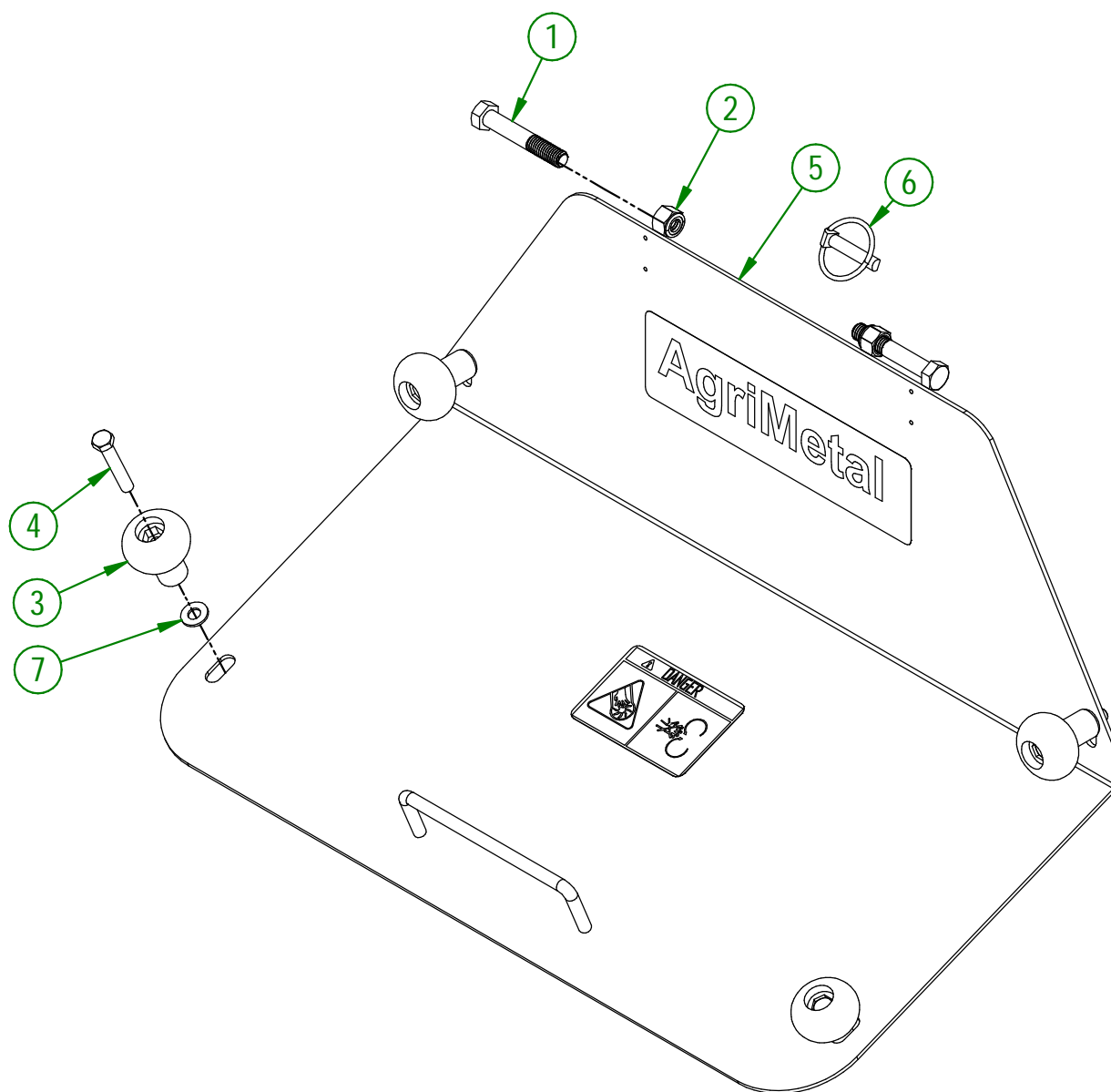

<b>AGRIMETAL</b>	
<b>IMPELLER ACCESS DOOR GROUP</b>	
CREATION : 04/12/17	ASSEMBLY : <b>84-57-0035</b>
REVISION : 22/12/25	AUTHOR :

#	PART #	Qty	TITLE
1	82-50-0051	1	IMPELLER
2	NC01-37-0121	2	HEX. BOLT GR8 ZINC 3/8-24 X 2 3/4" LG
3	NC01-94-0011	2	LOCK NUT 3/8-24
4	80-04-0185	1	WASHER
5	NC01-25-0395	1	HEX. BOLT GR5 ZINC 5/8-11 X 1 3/4" LG
6	NC02-32-0016	1	LOCK WASHER ZINC 5/8"

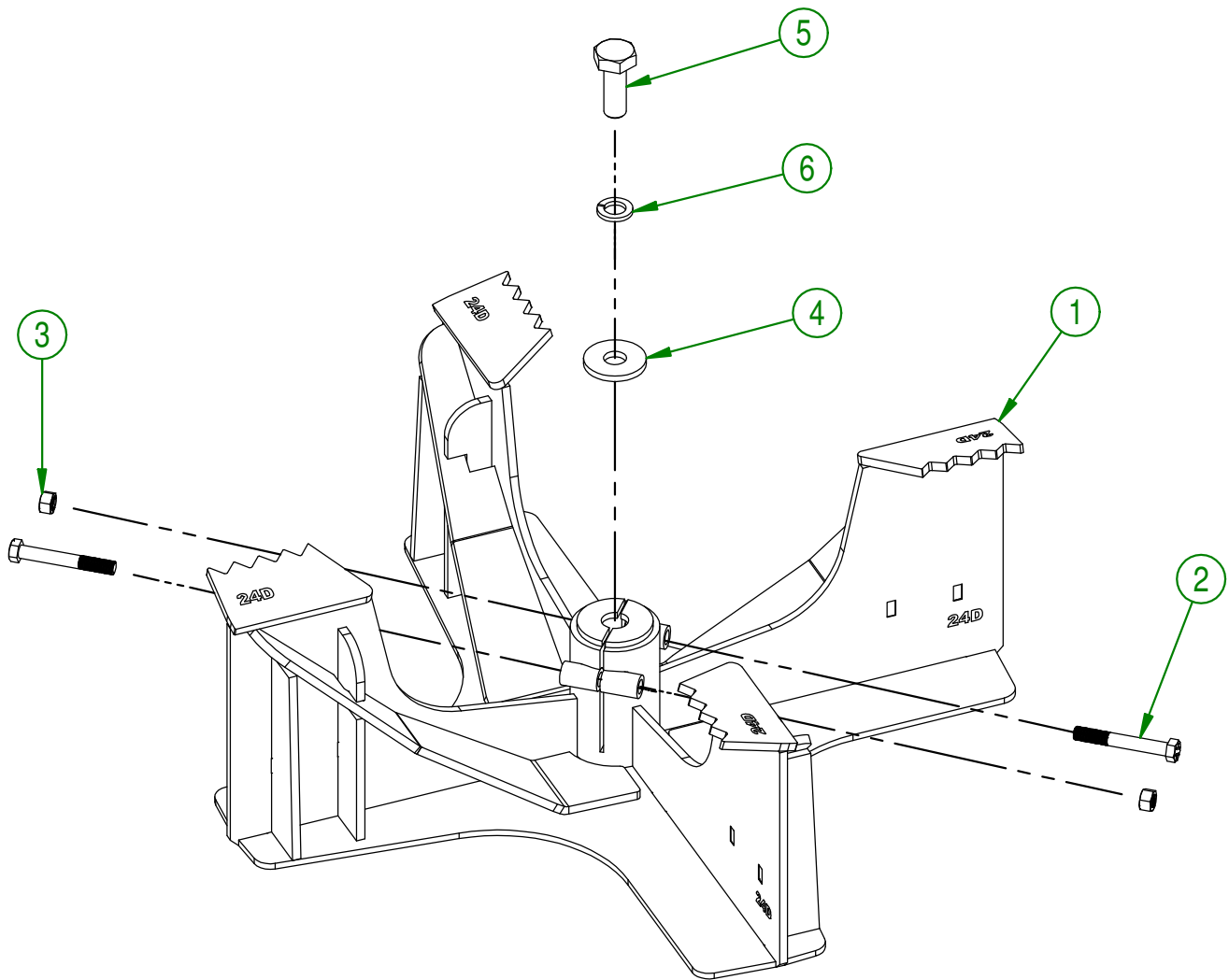

<b>AGRIMETAL</b>	
<b>IMPELLER GROUP</b>	
CREATION : 16/04/18	ASSEMBLY : <b>82-57-1926</b>
REVISION : 25/06/20	AUTHOR : F.HÉLIE
	Page 9 de 19

#	PART #	Qty	TITLE
1	NC14-75-0160	2	FLANGE BEARING 4 HOLES UCF 207-20 X 1 1/4"
2	NC02-25-0011	8	WASHER SAE ZINC 17/32 ID
3	84-50-0580	1	SPIRAL
4	NC01-17-0251	4	HEX. BOLT GR2 ZINC 1/2-13 X 2"
5	NC01-17-0250	4	HEX. BOLT GR2 ZINC 1/2-13 X 1 3/4"
6	NC02-32-0014	8	LOCK WASHER ZINC 1/2"
7	NC02-07-0020	8	HEX. NUT ZINC 1/2-13
8	84-01-3000	1	SPIRAL BEARING SHIM
9	NC14-55-0294	1	60A32H SPROCKET
10	NC01-37-0115	4	HEX. BOLT GR8 ZINC 3/8-24 X 1 1/4
11	NC01-94-0011	4	JAM NUT 3/8-24
12	82-51-0086	1	SHAFT OF THE SPIRAL
13	82-51-0091	1	SHAFT OF THE SPIRAL (SPROCKET)

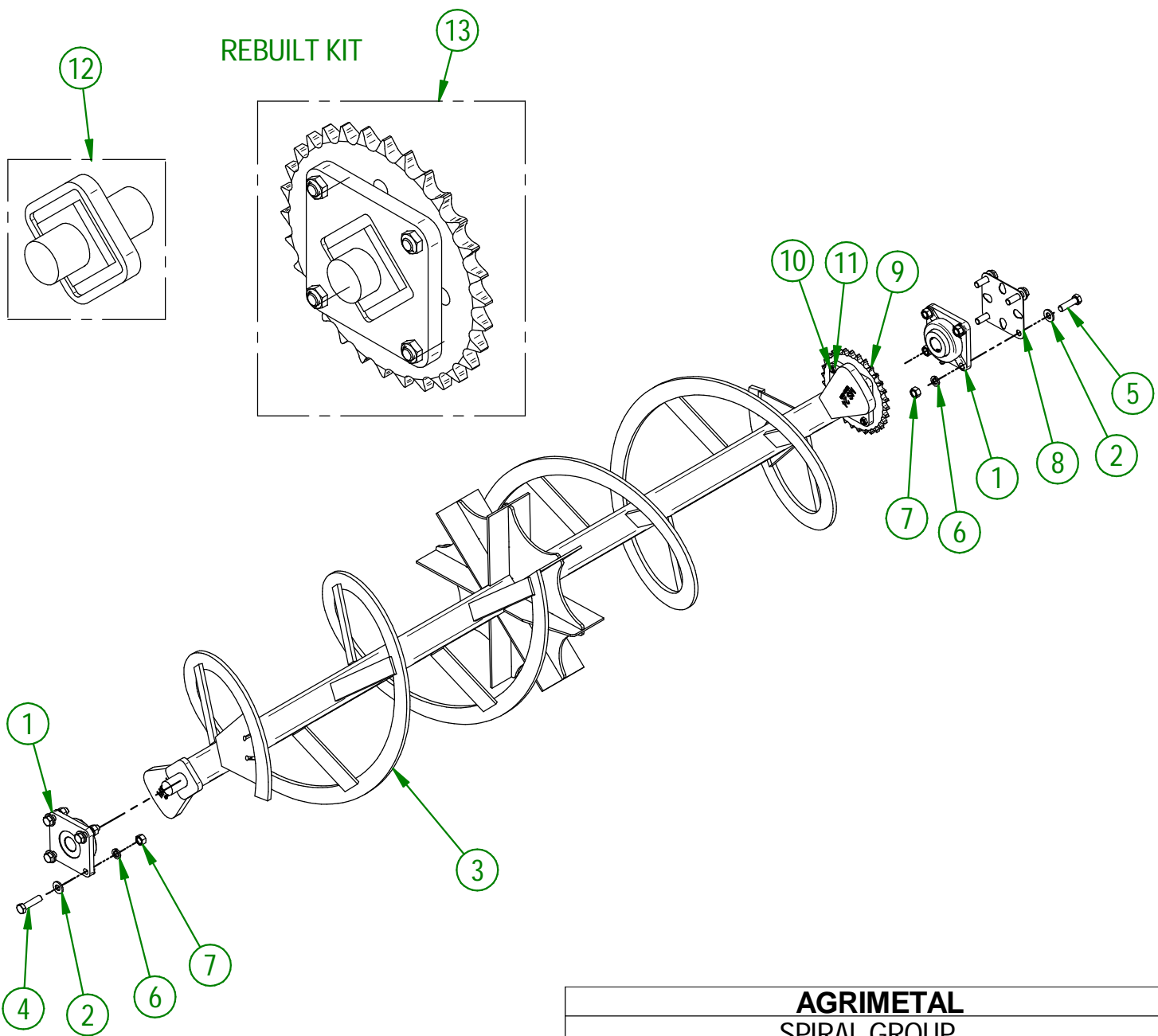

<b>AGRIMETAL</b>	
<b>SPIRAL GROUP</b>	
CREATION : 04/12/17	ASSEMBLY : <b>84-57-0025</b>
REVISION : 09/12/25	AUTHOR : Dessin2

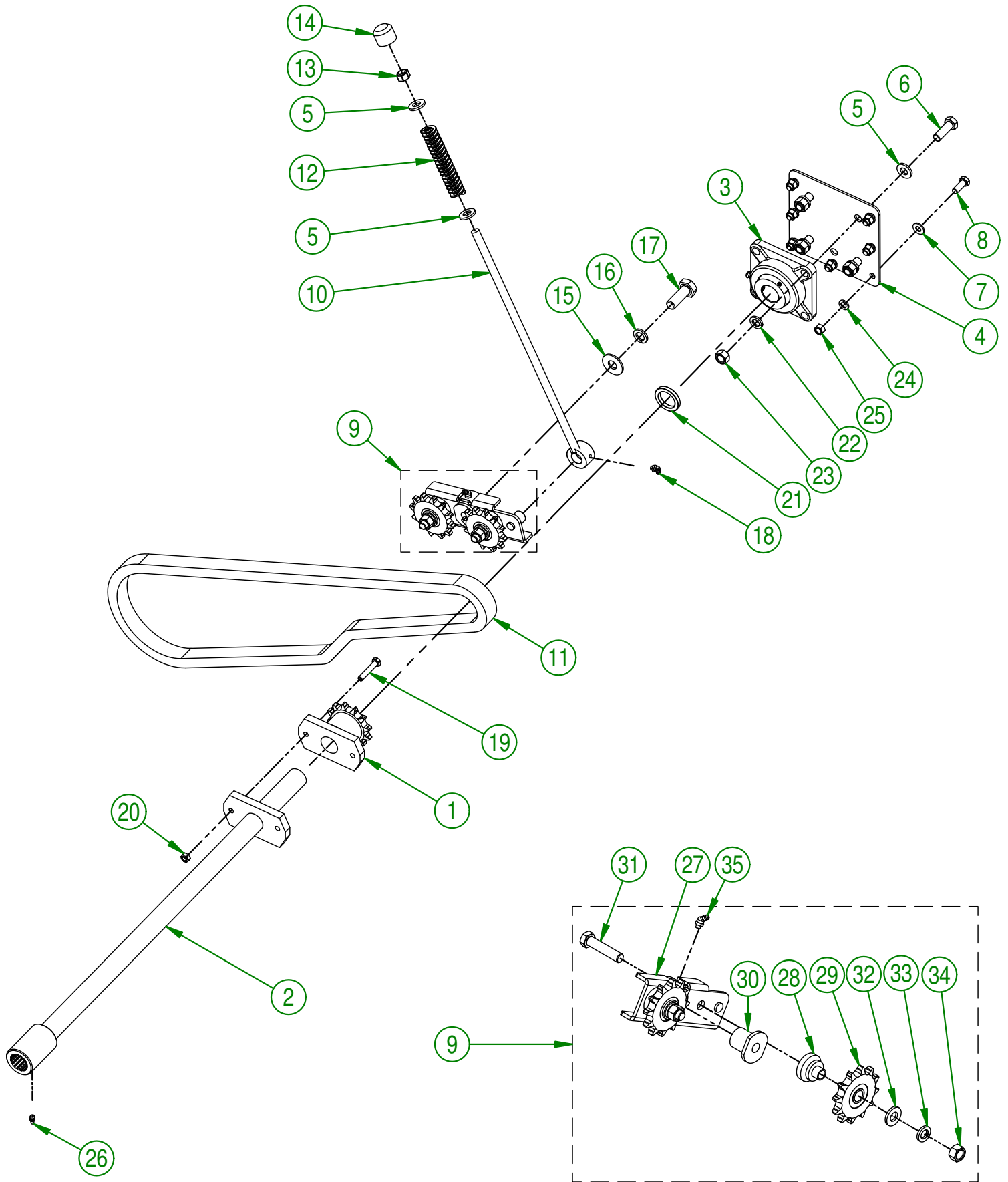

<b>AGRIMETAL</b>	
<b>SPIRAL DRIVE TRAIN GROUP</b>	
CREATION : 04/12/17	ASSEMBLY : <b>84-57-0030</b>
REVISION : 24/01/19	AUTHOR : <span style="float: right;">Page 11 de 19</span>

## 84-57-0030

#	PART #	Qty	TITLE
1	NC14-55-0293	1	60BI2H SPROCKET
2	84-50-0565	1	SPIRAL DRIVE TRAIN SHAFT
3	NC14-75-0160	1	FLANGE BEARING 4 HOLES UCF 207-20 X 1 1/4"
4	84-01-0905	1	COUNTER SHAFT BEARING SUPPORT
5	NC02-25-0011	6	WASHER SAE ZINC 17/32 ID
6	NC01-17-0249	4	HEX. BOLT GR2 ZINC 1/2-13 X 1 1/2"
7	01-01-2485	7	FLAT WASHER 14 GA X 13/16"OD X 25/64" ID
8	NC01-17-0114	7	HEX. BOLT GR2 ZINC 3/8-16 X 1"
9	80-55-0025	1	CHAIN TENSIONER GROUP
10	84-50-0040	1	THREADED ROD
11	84-37-1000	1	#60 HD CHAIN
12	NC13-86-0052	1	SPRING 1/2" ID X 1" OD X 5" LG
13	NC01-96-0014	1	NYLON-INSERT LOCKNUT ZINC 1/2-13
14	80-42-0110	1	THREADED ROD CAP
15	NC02-22-0013	1	WASHER ZINC 5/8 ID X 1 1/2 OD
16	NC02-32-0016	1	LOCK WASHER ZINC 5/8"
17	NC01-17-0395	1	HEX. BOLT GR2 ZINC 5/8-11 X 1 3/4"
18	NC01-69-0786	1	GREASE FITTING 1/4-28 X 45
19	NC01-17-0063	1	CAP SCREW GR2 NC ZINC 5/16-18 X 1 3/4"
20	NC01-93-0010	1	LOCK NUT ZINC 5/16-18
21	84-24-0000	1	SPIRAL DRIVE TRAIN BUSHING
22	NC02-32-0014	4	LOCK WASHER ZINC 1/2"
23	NC02-07-0020	4	HEX. NUT ZINC 1/2-13
24	NC02-32-0012	7	LOCK WASHER ZINC 3/8"
25	NC02-07-0018	7	HEX. NUT ZINC 3/8-16
26	NC01-69-0785	1	STRAIGHT GREASE FITTING 1/4-28

## 80-55-0025

#	PART #	Qty	TITLE
27	80-50-0045	1	CHAIN TENSIONER
28	80-21-0020	2	CHAIN TENSIONER BUSHING (SPROCKET)
29	NC14-55-0295	2	SPROCKET 60A12H
30	80-13-2400	1	CHAIN TENSIONER BUSHING
31	NC01-29-0252	2	HEX. BOLT GR2 ZINC 1/2-20 X 2 1/4" LG
32	NC02-25-0011	2	WASHER SAE ZINC 17/32 ID
33	NC02-32-0014	2	LOCK WASHER ZINC 1/2"
34	NC02-10-0020	2	HEX. NUT ZINC 1/2-20
35	NC01-69-0786	1	GREASE FITTING 1/4-28 X 45

#	PART #	Qty	TITLE
1	01-01-2485	4	FLAT WASHER
2	NC01-17-0114	2	HEX. BOLT GR2 ZINC 3/8-16 X 1"
3	NC01-96-0011	2	NYLON NUT 3/8-16
4	84-57-0055	1	CHAIN GUARD

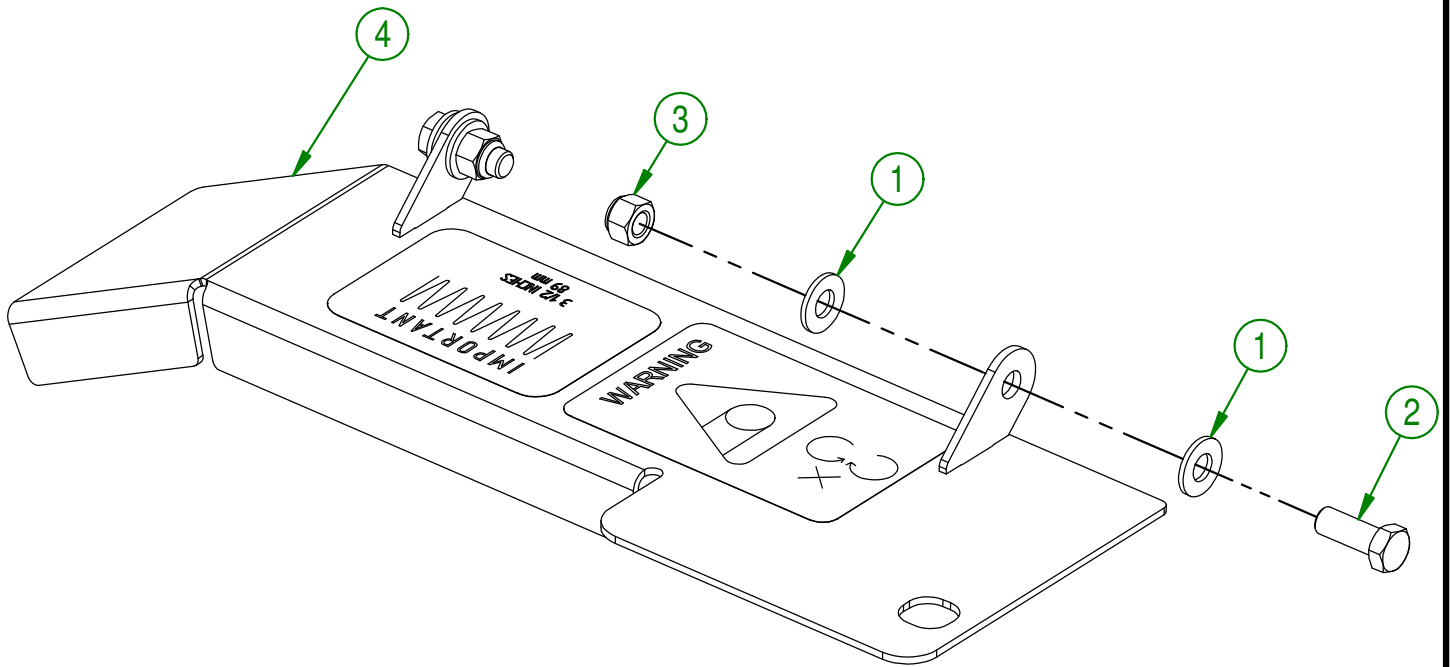

<b>AGRIMETAL</b>	
<b>CHAIN GUARD GROUP</b>	
CREATION : 05/12/17	ASSEMBLY : <b>84-57-0060</b>
REVISION : 05/12/17	AUTHOR : F.HÉLIE Page 13 de 19

#	PART #	Qty	TITLE
1	84-55-0010	1	GEARBOX
2	80-57-0040	1	PTO GUARD
3	NC02-25-0011	14	WASHER SAE ZINC 17/32 ID
4	NC02-32-0014	12	LOCK WASHER ZINC 1/2"
5	NC01-33-0248	8	HEX. BOLT .GR8 NC ZINC 1/2-13 X 1 1/4"
6	NC01-63-0027	1	HAIRPIN COTTER
7	80-41-0135	1	PTO GUARD STEEL CABLE
8	NC01-64-0005	2	OVAL SLEEVE (ALUMINUM)
9	80-41-0900	1	IMPELLER KEY
10	NCI3-50-0110	1	IMPORTANT/NOTICE PTO POSTER
11	NCI3-25-0019	1	BLACK TIE RAP
12	80-34-0030	1	PTO SHAFT T60
13	84-01-0090	1	PTO GUARD SUPPORT
14	80-04-0485	1	GEARBOX BRACE
15	NC01-33-0249	4	CAP SCREW GR8 NC ZINC 1/2-13 X 1 1/2" LG
16	NC02-07-0020	4	HEX. NUT ZINC 1/2-13
17	80-04-0480	1	GEARBOX BRACE
18	84-04-0660	2	GEARBOX SPACER

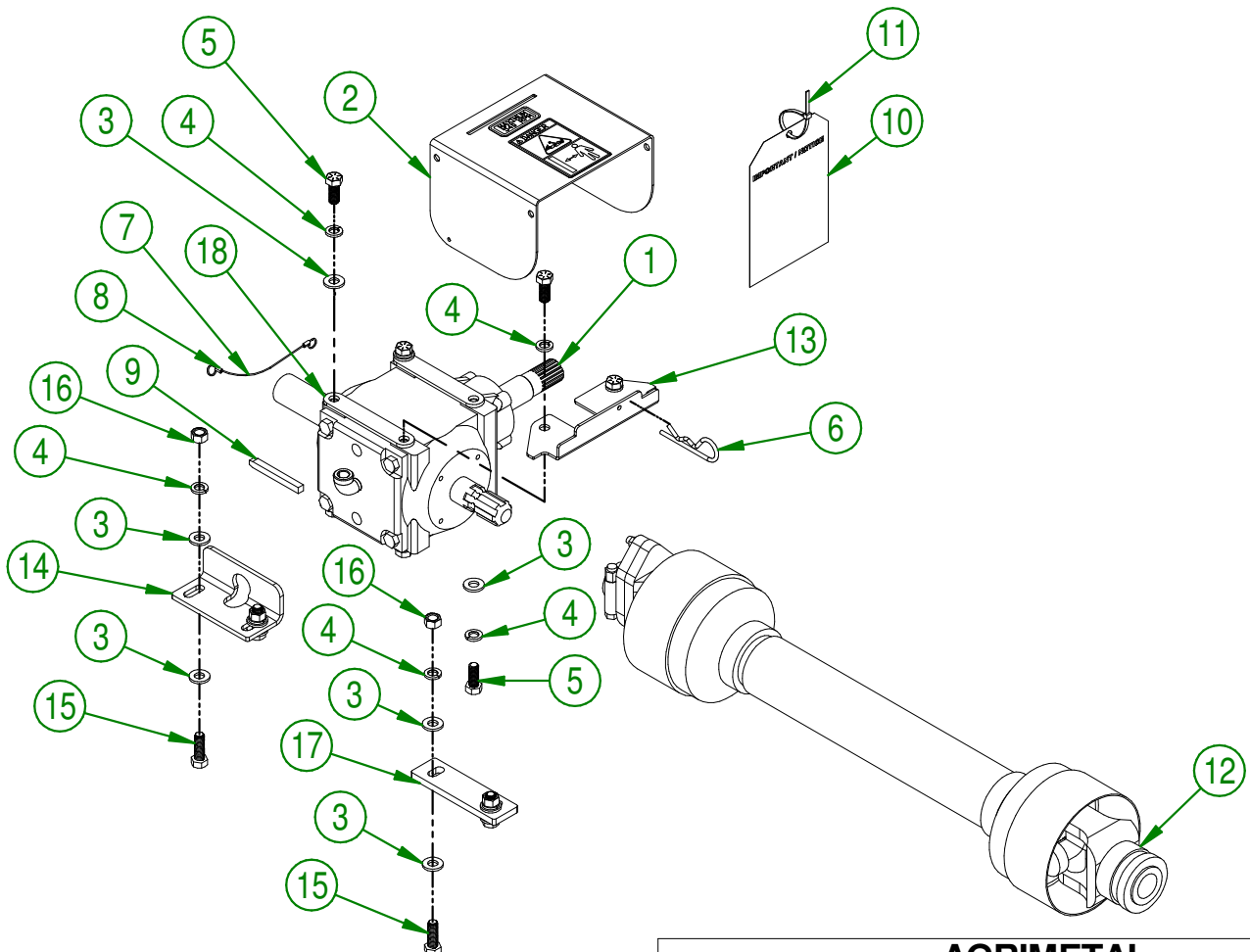

**AGRIMETAL**  
GEARBOX GROUP

CREATION : 05/12/17  
REVISION : 11/11/20

ASSEMBLY : **84-57-0080**  
AUTHOR : F.HÉLIE

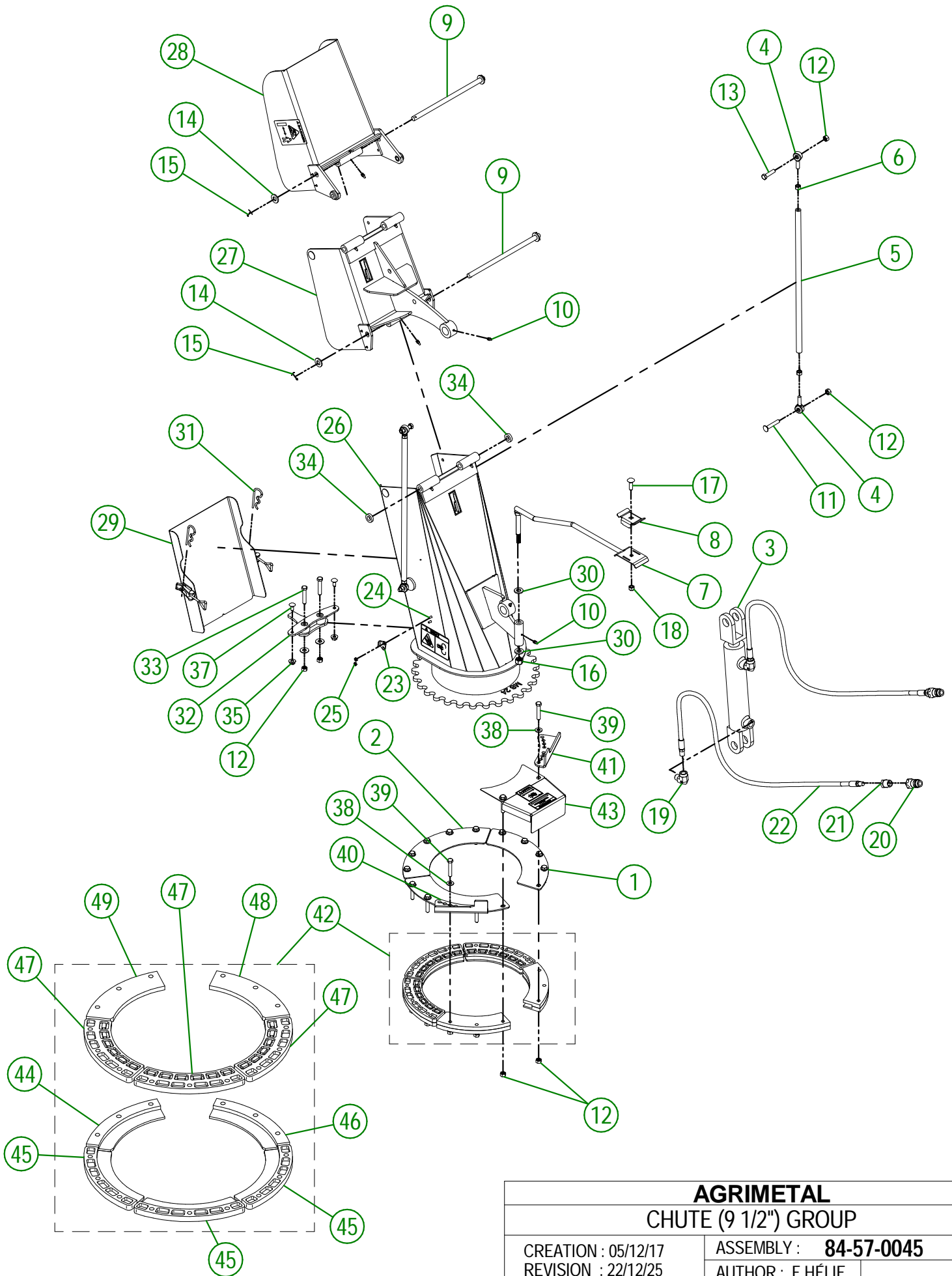

**AGRIMETAL**  
**CHUTE (9 1/2") GROUP**

CREATION : 05/12/17  
 REVISION : 22/12/25

ASSEMBLY : **84-57-0045**  
 AUTHOR : F.HÉLIE

## 84-57-0045

#	PART #	Qty	TITLE
1	82-01-0965	2	BRACE
2	82-01-0955	1	BRACE
3	NC13-45-0404	1	HYDRAULIC CYLINDER 6"
4	NC01-67-0304	4	ROD END 3/8-24
5	48-13-0600	2	CHUTE ROD (DOUBLE)
6	NC02-10-0018	4	NUT 3/8-24
7	48-50-1030	1	HYDRAULIC HOSE SUPPORT
8	48-01-7530	1	HYDRAULIC HOSE SUPPORT
9	82-20-0250	2	PIVOT
10	NC01-69-0785	9	STRAIGHT GREASE FITTING 1/4-28
11	NC01-07-0113	2	CARR. BOLT GR5 ZINC 3/8-16 X 2" LG
12	NC01-93-0011	21	LOCK NUT 3/8-16
13	NC01-25-0116	2	HEX. BOLT GR5 ZINC 3/8-16 X 1 1/2"
14	NC02-25-0011	4	WASHER SAE ZINC 17/32 ID
15	NC01-69-0139	4	COTTER PIN ZINC 1/8" X 3/4"
16	NC01-96-0014	1	NYLON-INSERT LOCKNUT ZINC 1/2-13
17	NC01-07-0110	1	CARR. BOLT GR5 ZINC 3/8-16 X 1 1/4"
18	NC01-96-0011	1	NYLON NUT 3/8-16
19	NC13-45-0038	2	ELBOW 90 3/8 FEM. NPT X 3/8 MALE NPT
20	NC13-45-0369	2	QUICK COUPLER 1/2-14 NPTF
21	NC13-45-0153	2	HEX. REDUCER 1/4 NPT X 1/2 NPT
22	NC17-02-0329	2	HYDRAULIC HOSE (87" LG)
23	NC01-63-0052	2	ADJUSTABLE LATCH (STRIKE)
24	NC02-40-0080	4	MACHINE SCREWS SQUARE SOCKET #10-24 X 1/2" LG
25	NC01-96-0006	4	NYLON NUT ZINC 3/16
26	84-57-0300	1	CHUTE (BOTTOM SECTION)
27	82-57-0311	1	CHUTE (MIDDLE SECTION)
28	82-57-0321	1	CHUTE (TOP SECTION)
29	82-57-0352	1	CHUTE DOOR
30	NC02-25-0011	2	WASHER SAE ZINC 17/32 ID
31	NC01-63-0026	2	COTTER PIN ZC 5/32" X 3"
32	84-50-0600	1	STOPPER
33	NC01-37-0118	2	HEX. BOLT GR8 ZINC 3/8-24 X 2"
34	NC13-15-0334	2	PIVOT WASHER
35	NC02-14-0006	2	HEX. NUT SPECIAL FLANGET NC 5/16-18 B GRADE
36	NC02-22-0010	2	WASHER 13/32" ID
37	NC01-07-0056	2	CARR. BOLT GR5 NC ZINC 5/16-18 X 3/4"
38	NC02-26-1525	15	WASHER INOX .406" D.I. X .815" D.E.
39	NC01-25-0118	15	HEX. BOLT GR5 NC ZINC 3/8-16 X 2"
40	84-04-0180	1	ADJUSTABLE STOPPER
41	84-04-0183	1	ADJUSTABLE STOPPER
42	84-57-1325	1	CHUTE GUIDE GROUP
43	84-57-0500	1	SPROCKET GUARD GROUP "STICKER INCLUDED"

84-57-1325

#	PART #	Qty	TITLE
44	46-42-0107	1	CHUTE GUIDE (UNDER)
45	NC17-46-0030	3	CHUTE GUIDE (UNDER)
46	46-42-0106	1	CHUTE GUIDE (UNDER)
47	NC17-46-0029	3	CHUTE GUIDE (TOP)
48	46-42-0101	1	CHUTE GUIDE (TOP)
49	46-42-0102	1	CHUTE GUIDE (TOP)

#	PART #	Qty	TITLE
1	48-01-7527	1	HYDRAULIC HOSE SUPPORT
2	48-50-1025	1	HYDRAULIC ENGINE SPROCKET
3	80-13-0100	2	HYDRAULIC RESTRICTOR
4	80-45-0000	2	HEX. REDUCER 1/4 NPT X 1/2 NPT
5	81-01-7600	1	HYDRAULIC HOSE SUPPORT
6	NC01-07-0111	1	CARR. BOLT GR5 ZINC 3/8-16 X 1 1/2"
7	NC01-17-0115	2	HEX. BOLT GR2 ZINC 3/8-16 X 1 1/4"
8	NC01-33-0113	4	HEX.BOLT GR8 ZINC 3/8-16 X 3/4"
9	NC01-45-0184	1	HEX. BOLT GR8.8 ZINC 8MM X 20MM
10	NC01-96-0011	1	NYLON NUT 3/8-16
11	NC02-07-0018	2	HEX. NUT ZINC 3/8-16
12	NC02-26-0504	1	WASHER
13	NC02-26-1525	2	WASHER INOX .406" D.I. X .815" D.E.
14	NC02-32-0011	1	LOCK WASHER ZINC 5/16"
15	NC02-32-0012	6	LOCK WASHER ZINC 3/8"
16	NC02-44-0103	2	SET SCREW 5/16-18 X 3/8"
17	NC13-45-0367	2	45°-7/8-14 MALE O RING X 1/2 FEM.TOUR.NPT PT
18	NC13-45-0369	2	QUICK COUPLER 1/2-14 NPTF
19	NC13-45-0378	2	HYDRAULIC RESTRICTOR BUSHING
20	NC14-45-0156	1	HYDRAULIC MOTOR
21	NC17-02-0328	2	HYDRAULIC HOSE (63" LG)
22	NC17-46-0031	1	HYDRAULIC MOTOR BUSHING

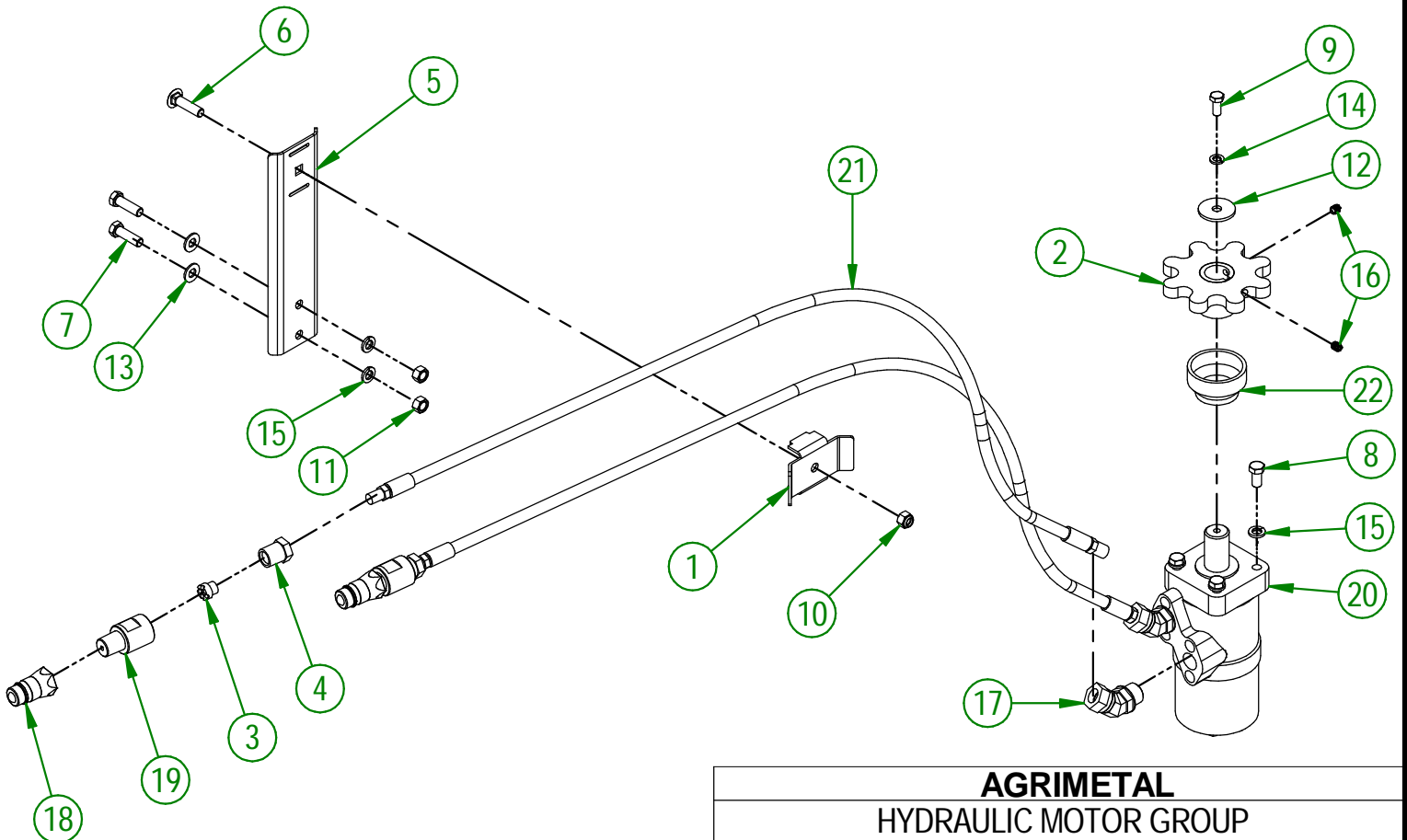

**AGRIMETAL**  
**HYDRAULIC MOTOR GROUP**

CREATION : 05/08/19  
 REVISION : 25/03/26

ASSEMBLY : **84-57-0410**  
 AUTHOR : F.HÉLIE

84-57-0070

#	PART #	Qty	TITLE
1	NCI3-30-0237	1	PLASTIC TUBE FOR OPERATOR'S MANUAL
2	NC02-22-0008	2	WASHER ZINC 5/16"
3	NC01-17-0007	2	HEX. BOLT GR2 ZINC 1/4-20 X 1 1/4"
4	NC01-96-0009	2	NYLON-INSERT LOCKNUT ZINC 1/4-20
5	80-57-0030	1	SET OF 6 SHEAR BOLT WITH NUT
6	84-98-0520	1	ENGLISH OPERATOR'S MANUAL (MS2692-i, MS2482-i)

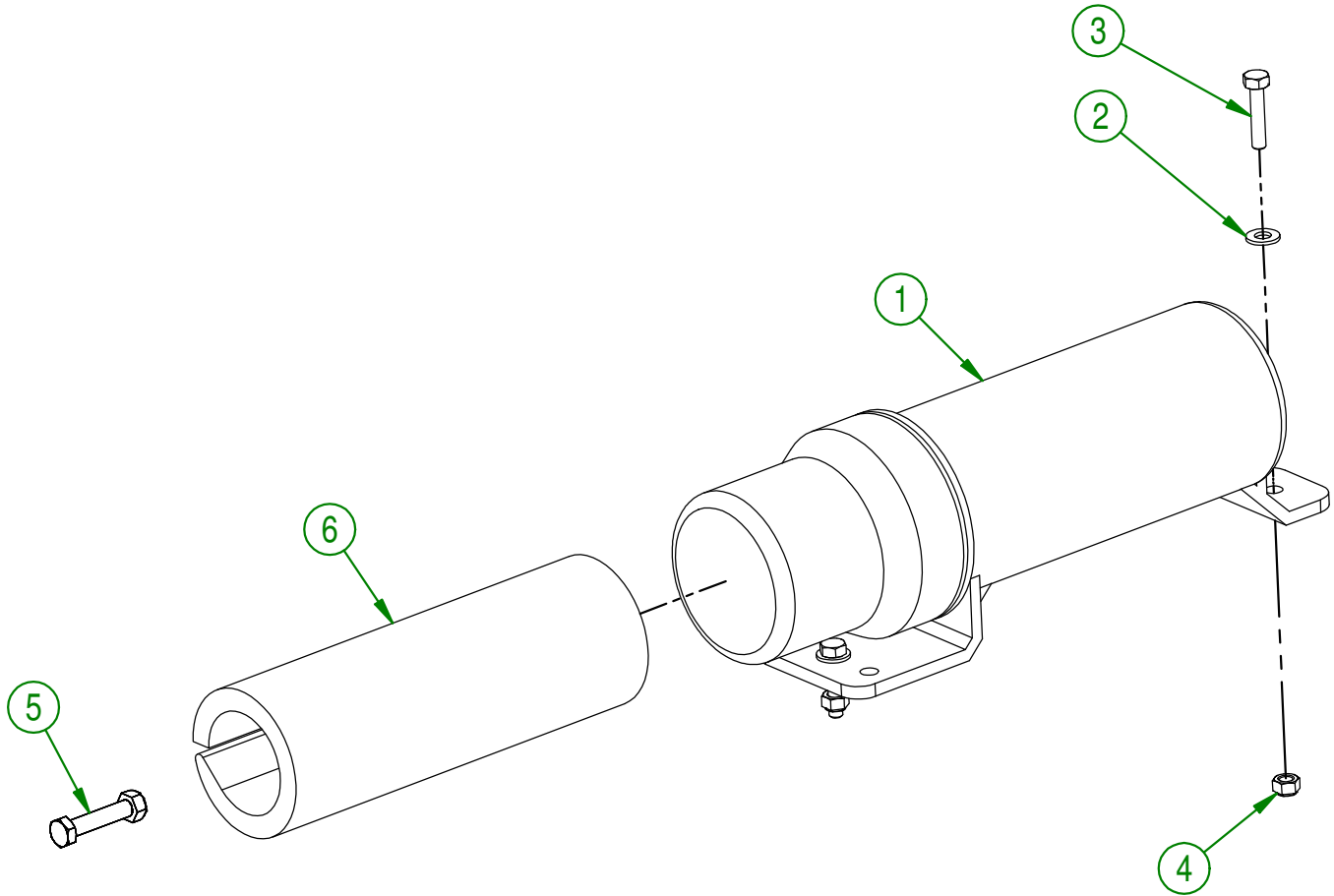

<b>AGRIMETAL</b>	
<b>OPERATOR'S MANUAL TUBE GROUP</b>	
CREATION : 05/12/17	ASSEMBLY : <b>84-57-0070</b>
REVISION : 03/01/18	AUTHOR : F.HÉLIE   Page 18 de 19

#	PART #	QTY	TITLE
1	NCI3-33-0249	4	STICKER DANGER
2	NCI3-33-0035	3	STICKER AGRIMETAL
3	NCI3-33-0024	6	STICKER GREASE HERE
4	NCI3-33-0192	2	STICKER (PROJECTION RISK)
5	NCI3-33-0327	1	STICKER END ROTATION ADJUSTMENT
6	NCI3-33-0326	1	STICKER DANGER (HAND)
7	NCI3-33-0283	1	STICKER DANGER (PERSON AND CHAIN DRIVE)
8	NCI3-33-0070	1	STICKER SPRING IMPORTANT STICKER AT 3 1/2 INCHES, 89 MM
9	NCI3-33-0241	1	STICKER MAX-SNOW COMMERCIAL
10	NCI3-33-0302	1	STICKER 2482-i
11	NCI3-33-0280	1	STICKER SHEAR BOLT
12	NCI3-33-0274	2	STICKER DANGER
13	NCI3-33-0189	1	STICKER DANGER (PERSON AND CHAIN DRIVE)
14	NCI3-50-0086	1	SERIAL NUMBER PLATE
15	NCI3-33-0317	1	STICKER GREASE DRIVE LINE TELESCOPIC SHAFT
16	NCI3-33-0187	1	STICKER DANGER (PTO AND PERSON)
17	NCI3-33-0005	1	STICKER MAXIMUM 540 RPM

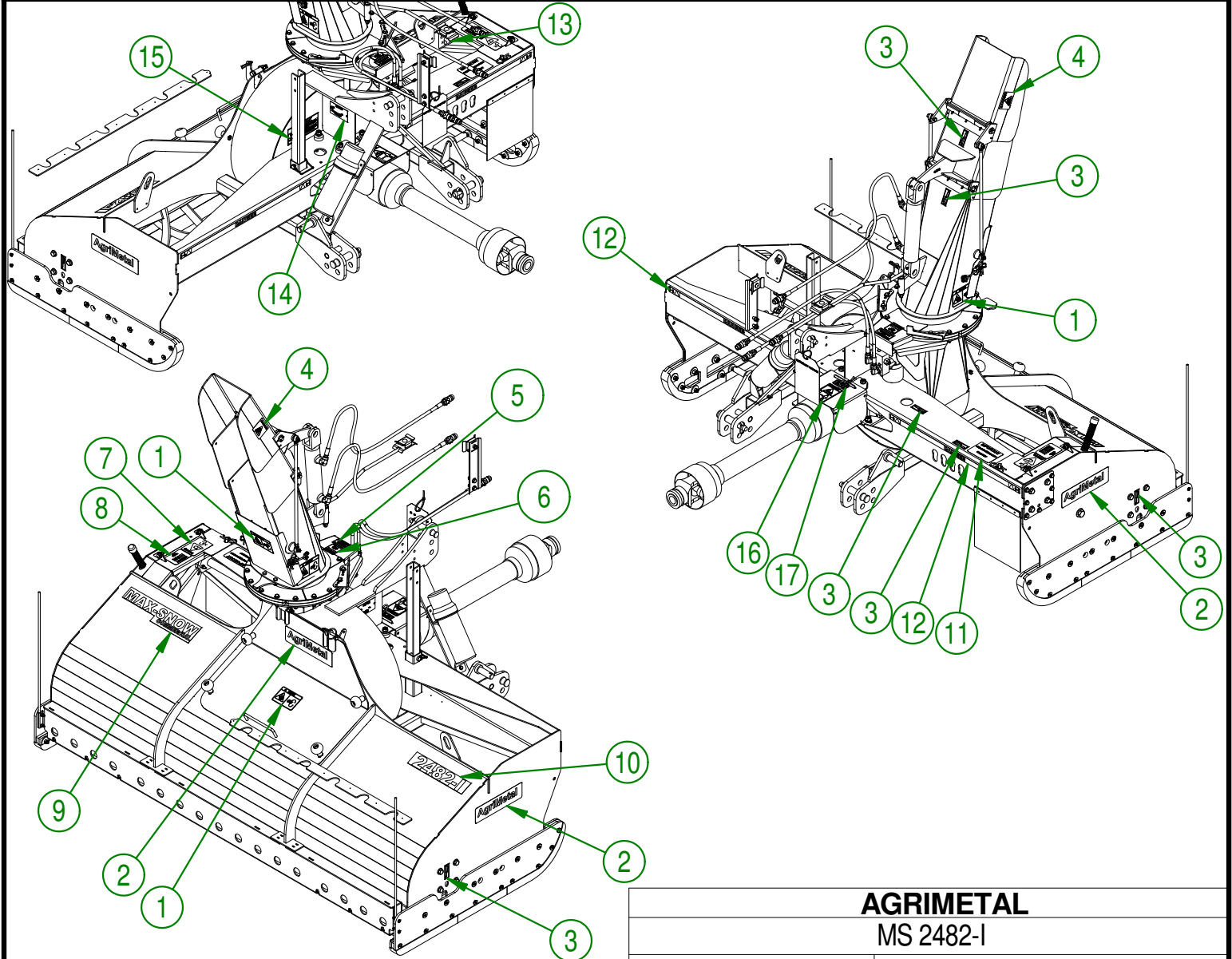

**AGRIMETAL**

MS 2482-I

CREATION : 07/12/17  
 REVISION : 25/04/19

ASSEMBLY : **84-99-0001**

AUTHOR : F.HÉLIE Page 19 de 19