

AgriMetal

PARTS LIST

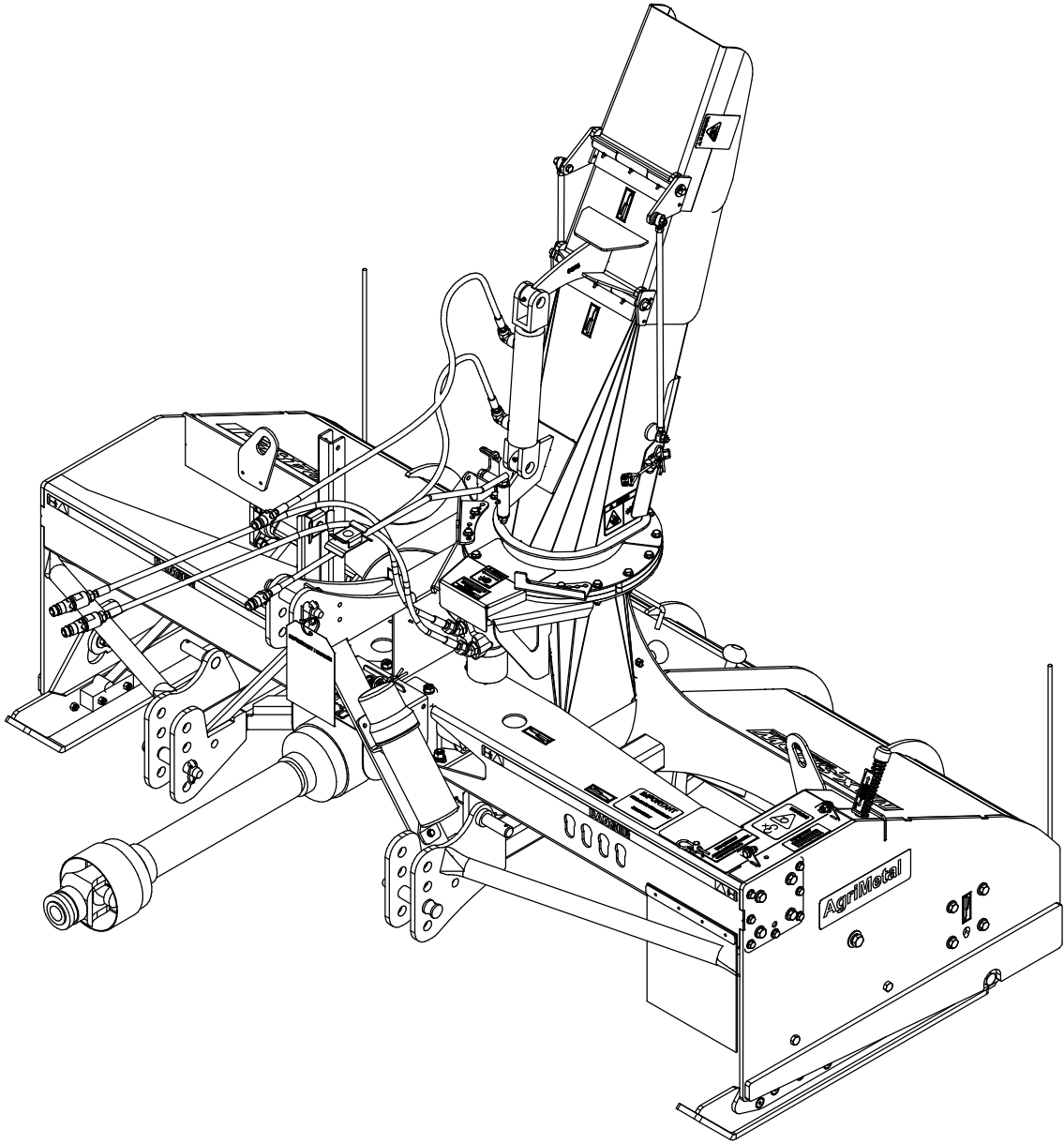

MS 2482-i

#	PART #	Qty	TITLE
1	84-20-0135	2	QT-400 KNIFE
2	NC01-25-0250	12	HEX.BOLT GR5 NC ZINC 1/2-13 X 1 3/4"
3	NC01-93-0014	12	LOCK NUT ZINC 1/2-13
4	NC02-48-0533	8	STAINLESS FLAT HEAD SOCKET CAP SREW 3/8-16 X 1 1/4"
5	NC01-96-0011	12	NYLON NUT 3/8-16
6	84-50-0441	1	GAUCHE FLOATING SKATE (QT-450)
7	84-42-0341	2	WEAR STRIP FOR SPRING BLADE
8	NC01-69-0785	2	STRAIGHT GREASE FITTING 1/4-28
9	84-50-0442	1	RIGHT FLOATING SKATE (QT-450)
10	NC02-48-0539	4	STAINLESS FLAT HEAD SOCKET CAP SREW 3/8-16 X 2 3/4"

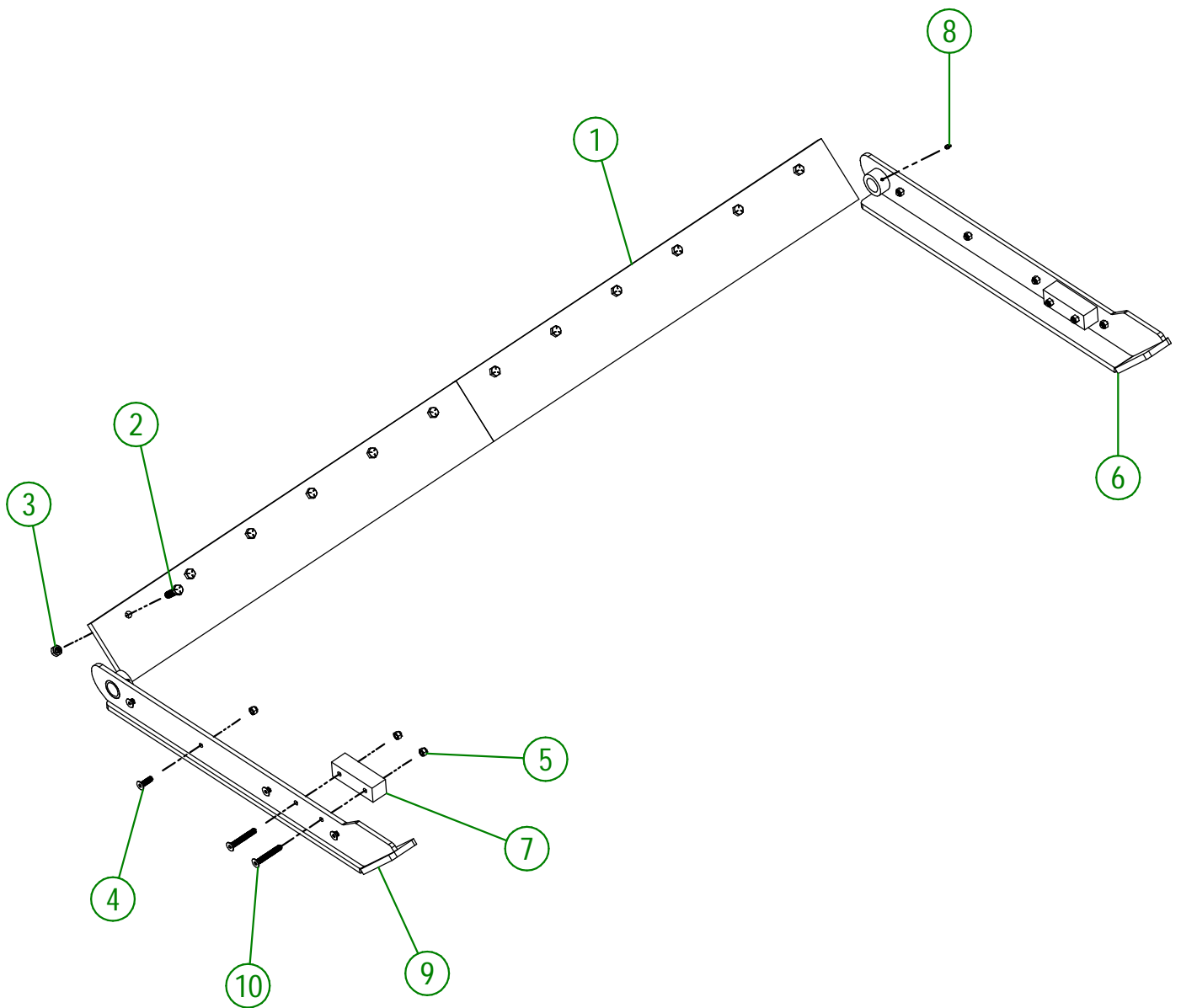

AGRIMETAL	
QT-400 KNIFE GROUP	
CREATION : 17/01/22	ASSEMBLY : 84-57-0257
REVISION : 07/12/22	AUTHOR : J. Houle

84-57-0390

#	PART #	QTY	TITLE
1	84-50-0310	1	KNIFE HOLDER
2	84-20-0245	2	KNIFE (QT-450)
3	NC01-93-0014	24	LOCK NUT ZINC 1/2-13
4	NC01-25-0249	12	HEX. BOLT GR5 ZINC 1/2-13 X 1 1/2" LG
5	NC02-48-0545	13	FLAT HEAD SOCKET CAP SCREW 1/2"-13 X 1 1/4" (STAINLESS STEEL)
6	84-50-0610	1	LEFT FLOATING SKATE (QT-450)
7	84-42-0341	2	WEAR STRIP FOR SPRING BLADE
8	NC01-96-0011	12	NYLON NUT 3/8-16
9	NC02-48-0533	8	STAINLESS FLAT HEAD SOCKET CAP SREW 3/8-16 X 1 1/4"
10	NC02-48-0539	4	STAINLESS FLAT HEAD SOCKET CAP SREW 3/8-16 X 2 3/4"
11	NC01-69-0785	2	STRAIGHT GREASE FITTING 1/4-28
12	84-50-0613	1	RIGHT FLOATING SKATE (QT-450)
13	NC01-09-0029	12	PLOW BOLT GR5 1/2-13 X 1 1/4" LG

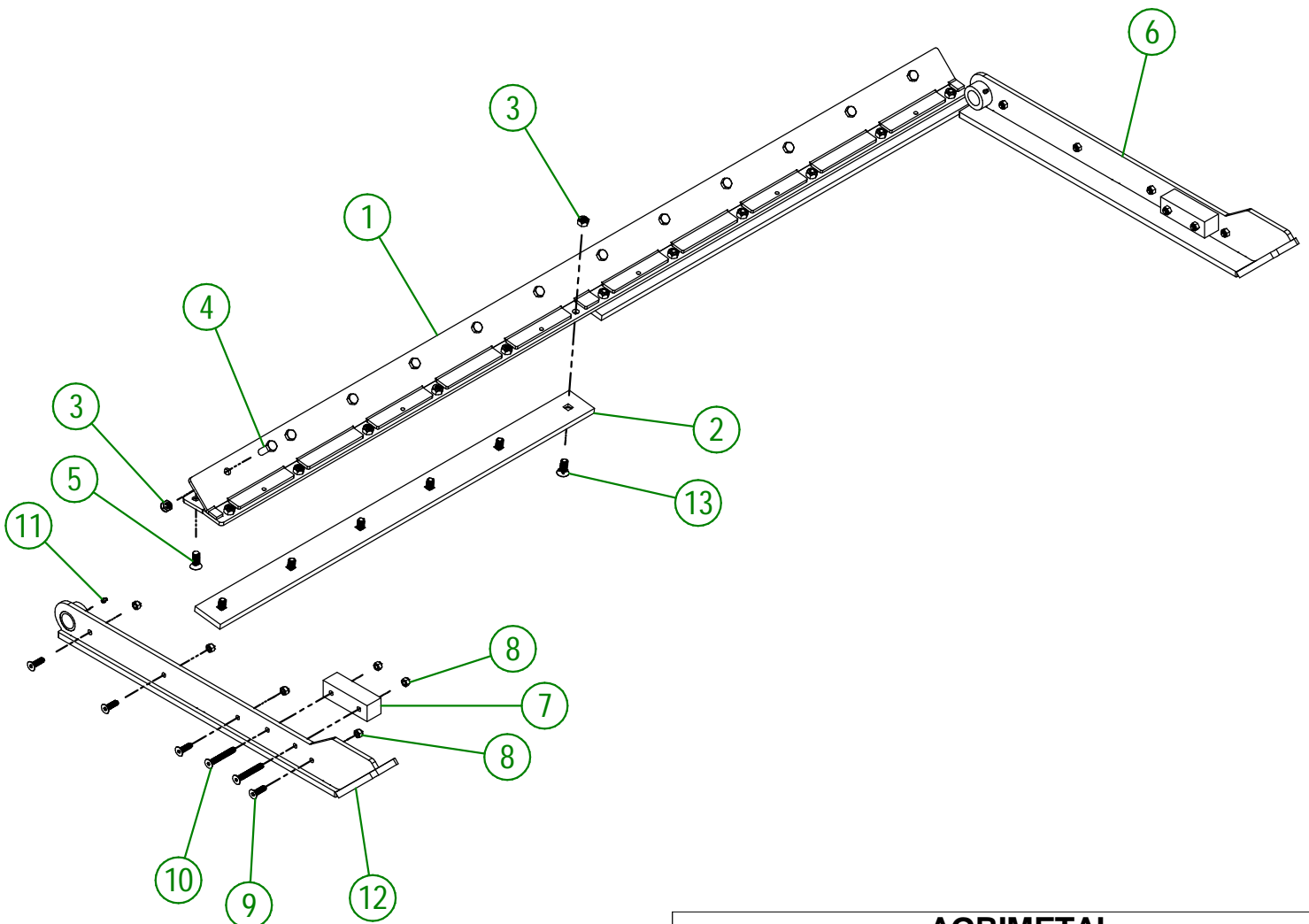

AGRIMETAL	
QT-450 KNIFE KIT	
CREATION : 13/05/25	ASSEMBLY : 84-57-0390
REVISION : 13/05/25	AUTHOR : J. Houle

#	PART #	Qty	TITLE
1	84-20-0140	2	STAINLESS KNIFE
2	NC01-25-0250	12	HEX. BOLT GR5 ZINC 1/2-13 X 1 3/4"
3	NC01-93-0014	12	LOCK NUT ZINC 1/2-13
4	NC02-48-0533	8	STAINLESS FLAT HEAD SOCKET CAP SREW 3/8-16 X 1 1/4"
5	NC01-96-0011	12	NYLON NUT 3/8-16
6	84-42-0341	2	WEAR STRIP FOR SPRING BLADE
7	NC01-69-0785	2	STRAIGHT GREASE FITTING 1/4-28
8	NC02-48-0539	4	STAINLESS FLAT HEAD SOCKET CAP SREW 3/8-16 X 2 3/4"
9	84-50-0466	1	RIGHT FLOATING SKATE (STAINLESS)
10	84-50-0465	1	LEFT FLOATING SKATE (STAINLESS)

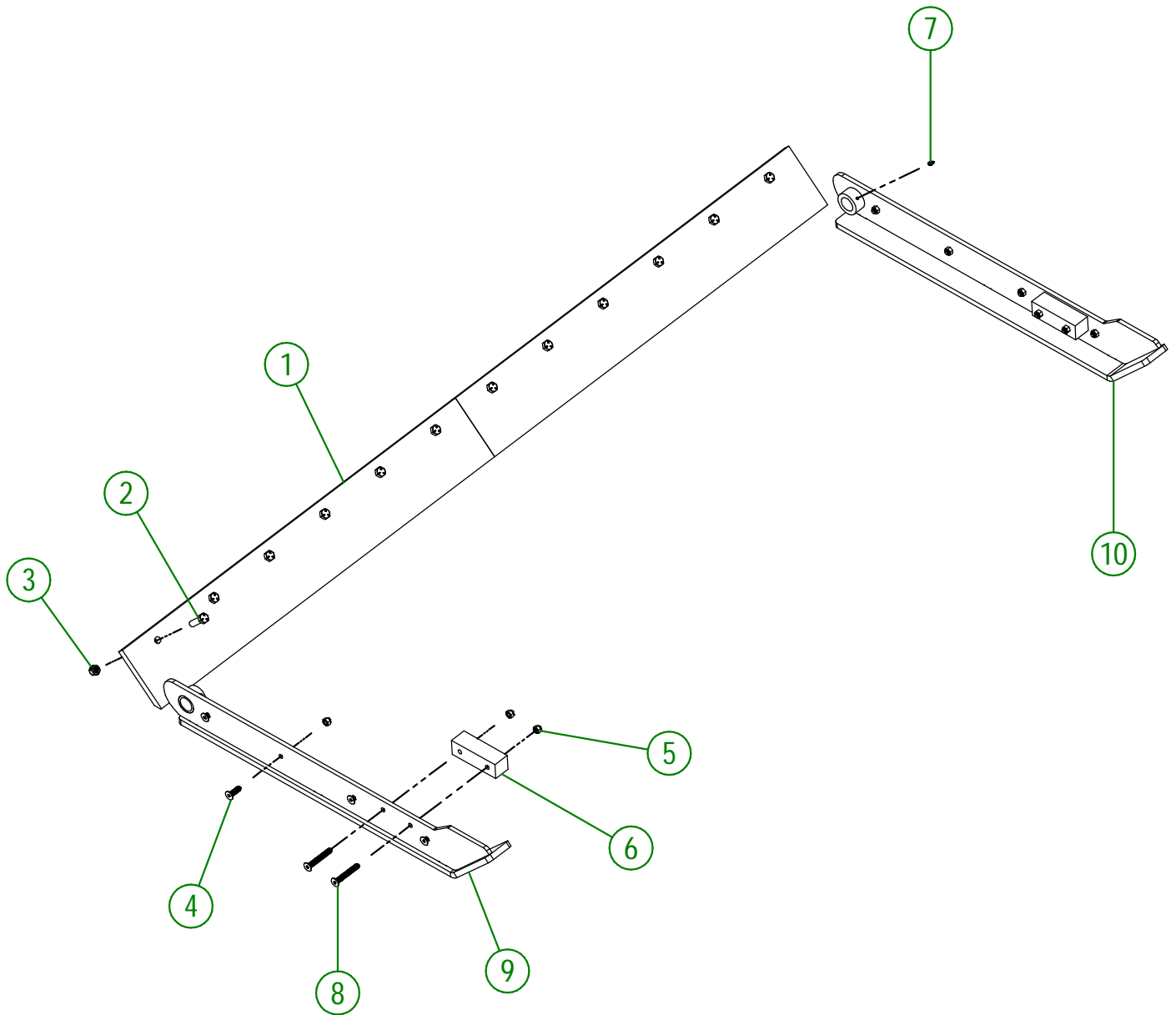

AGRIMETAL	
STAINLESS KNIFE GROUP	
CREATION : 17/01/22	ASSEMBLY : 84-57-0267
REVISION : 11/04/25	AUTHOR : J. Houle

84-57-0385

#	PART #	QTY	TITLE
1	84-50-0310	1	KNIFE HOLDER
2	84-20-0240	2	KNIFE (STAINLESS STEEL)
3	NC02-48-0545	25	FLAT HEAD SOCKET CAP SCREW 1/2"-13 X 1 1/4" (STAINLESS STEEL)
4	NC01-93-0014	24	LOCK NUT ZINC 1/2-13
5	NC01-25-0249	12	HEX. BOLT GR5 ZINC 1/2-13 X 1 1/2" LG
6	84-50-0605	1	LEFT FLOATING SKATE (QT-450)
7	84-42-0341	2	WEAR STRIP FOR SPRING BLADE
8	NC01-96-0011	12	NYLON NUT 3/8-16
9	NC02-48-0533	8	STAINLESS FLAT HEAD SOCKET CAP SREW 3/8-16 X 1 1/4"
10	NC02-48-0539	4	STAINLESS FLAT HEAD SOCKET CAP SREW 3/8-16 X 2 3/4"
11	NC01-69-0785	2	STRAIGHT GREASE FITTING 1/4-28
12	84-50-0607	1	RIGHT FLOATING SKATE (QT-450)

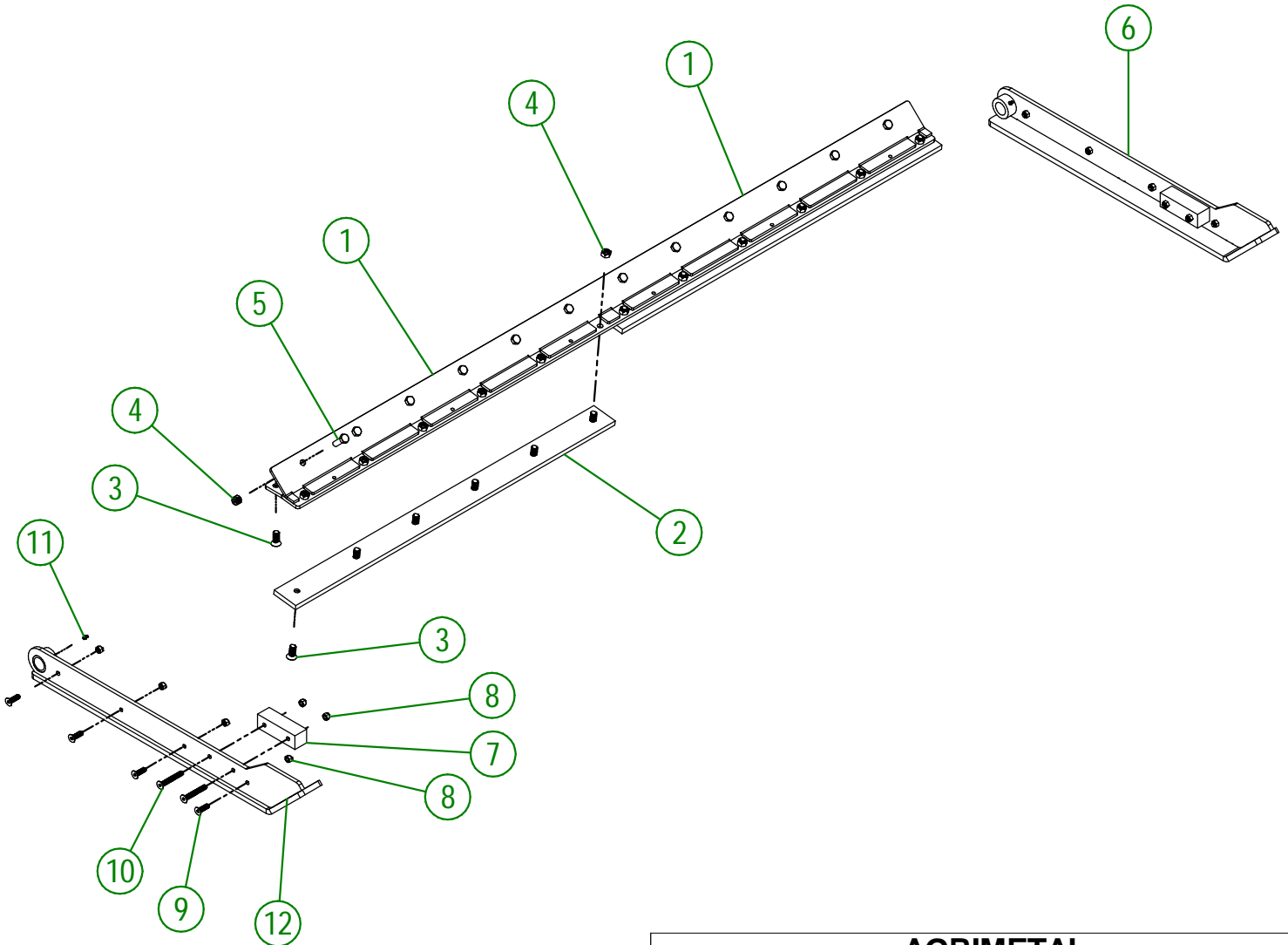

AGRIMETAL
STAINLESS STEEL KNIFE KIT

CREATION : 13/05/25
 REVISION : 13/05/25

ASSEMBLY : **84-57-0385**
 AUTHOR : J. Houle

#	PART #	Qty	TITLE
1	84-42-0251	2	UHMW KNIFE
2	84-20-0121	2	KNIFE BRACE
3	NC01-09-0032	12	PLOW BOLT GR5 1/2-13 X 2" LG
4	NC01-93-0014	12	LOCK NUT ZINC 1/2-13
5	84-42-2015	2	FLOATING SKATE
6	84-01-2021	2	FLOATING SKATE REINFORCEMENT
7	NC02-48-0037	8	FLAT HEAD SOCKET CAP SCREW 3/8-16 X 2 1/2" LG
8	NC01-96-0011	8	NYLON NUT 3/8-16

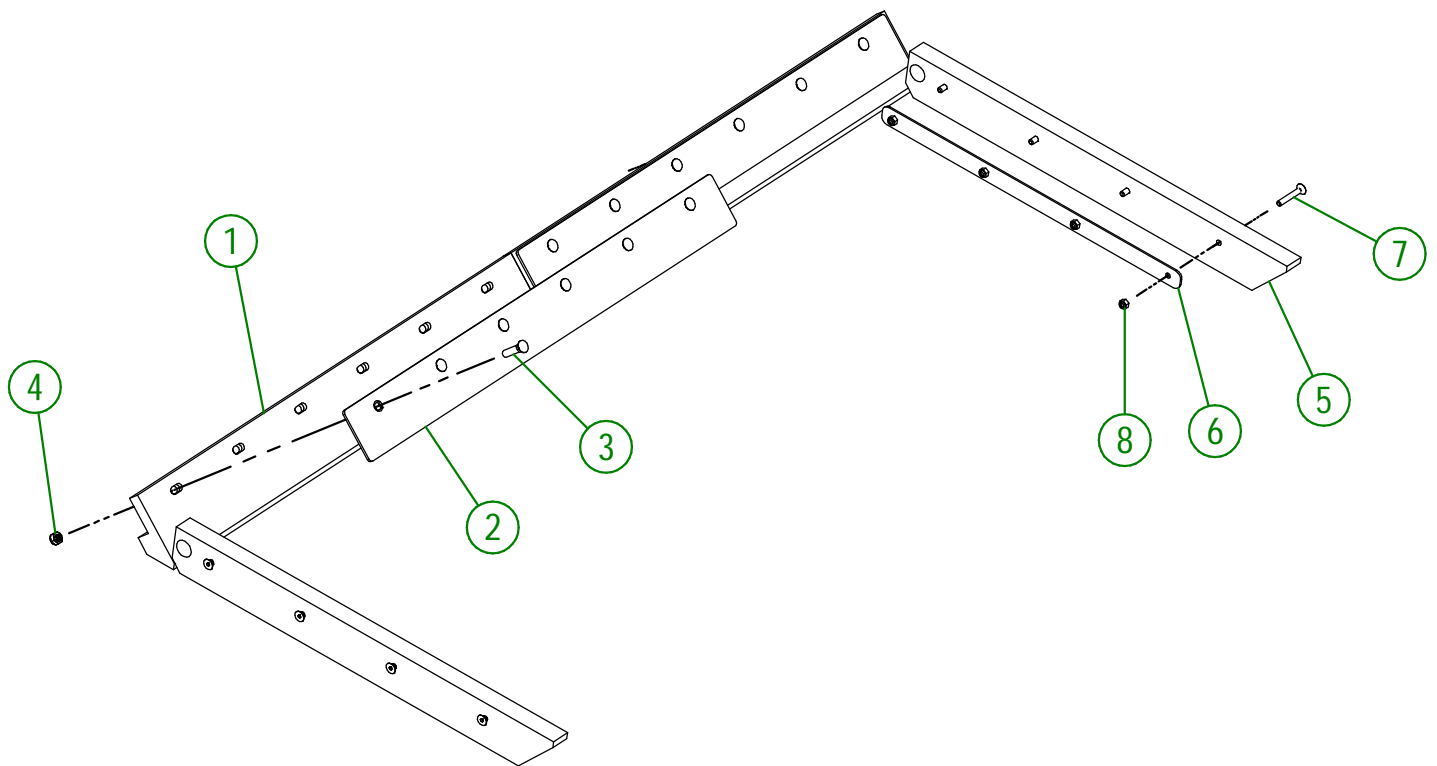

AGRIMETAL	
UHMW KNIFE GROUP	
CREATION : 17/01/22	ASSEMBLY : 84-57-0252
REVISION : 07/12/22	AUTHOR : J. Houle

#	PART #	Qty	TITLE
1	84-04-0541	2	RUBBER KNIFE BRACE
2	84-42-0075	2	KNIFE MS 24-i (RUBBER)
3	NC02-48-0045	13	FLAT SOCKET CAP SCREWS 1/2-13 X 1 1/4" GRADE 8
4	84-20-0121	2	KNIFE BRACE
5	NC01-09-0032	12	PLOW BOLT GR5 1/2-13 X 2" LG
6	NC01-93-0014	12	LOCK NUT ZINC 1/2-13
7	84-04-0543	1	RUBBER KNIFE BRACE
8	84-42-2015	2	FLOATING SKATE
9	84-01-2021	2	FLOATING SKATE REINFORCEMENT
10	NC02-48-0037	8	FLAT HEAD SOCKET CAP SCREW 3/8-16 X 2 1/2" LG
11	NC01-96-0011	8	NYLON NUT 3/8-16

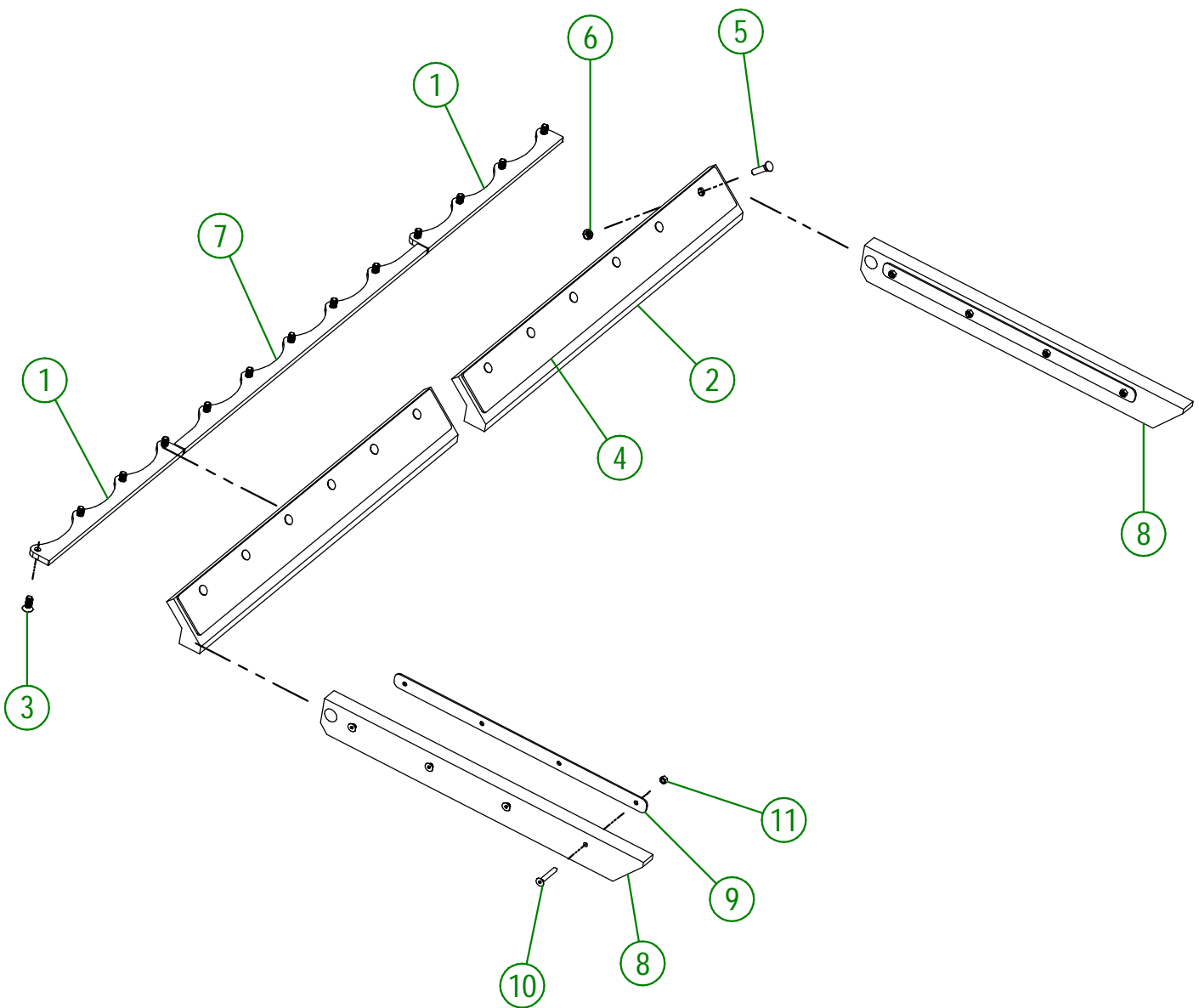

AGRIMETAL	
RUBBER KNIFE GROUP	
CREATION : 17/01/22	ASSEMBLY : 84-57-0270
REVISION : 07/12/22	AUTHOR : J. Houle

#	PART #	Qty	TITLE
1	84-01-9155	2	COLLAR SUPPORT GUIDE ROD CLAMPING
2	84-20-9045	1	HYDRAULIC SKI PLATE
3	84-25-0000	5	HYDRAULIC SKI PIVOT WEAR RING
4	84-50-9041	1	HYDRAULIC SKI
5	84-50-9047	2	HYDRAULIC CYLINDER SUPPORT
6	84-50-9060	1	ADJUSTABLE SKI RACK
7	84-50-9065	1	HYDRAULIC CYLINDER REINFORCEMENT
8	NC01-25-0114	14	HEX. BOLT GR5 ZINC 3/8-16 X 1"
9	NC01-25-0116	8	HEX. BOLT GR5 ZINC 3/8-16 X 1 1/2"
10	NC01-25-0248	4	HEX. BOLT GR5 ZINC 1/2-13 X 1 1/4"
11	NC01-25-0398	5	HEX. BOLT GR5 ZINC 5/8-11 X 2 1/2" LG
12	NC01-69-0785	4	STRAIGHT GREASE FITTING 1/4-28
13	NC01-93-0010	12	LOCK NUT ZINC 5/16-18
14	NC01-93-0011	12	LOCK NUT 3/8-16
15	NC01-96-0016	5	NYLON INSERT NUT 5/8-11
16	NC02-22-0008	12	WASHER ZINC 5/16"
17	NC02-25-0009	10	FLAT WASHER 14 GA X 13/16"OD X 25/64" ID
18	NC02-25-0011	4	WASHER SAE ZINC 17/32 ID
19	NC02-32-0012	10	LOCK WASHER ZINC 3/8"
20	NC02-32-0014	4	LOCK WASHER ZINC 1/2"
21	NC02-48-0021	12	FLAT HEAD SOCKET CAP SCREW 5/16-18 X 1"
22	NC13-45-0209	2	HYDRAULIC CYLINDER 6"

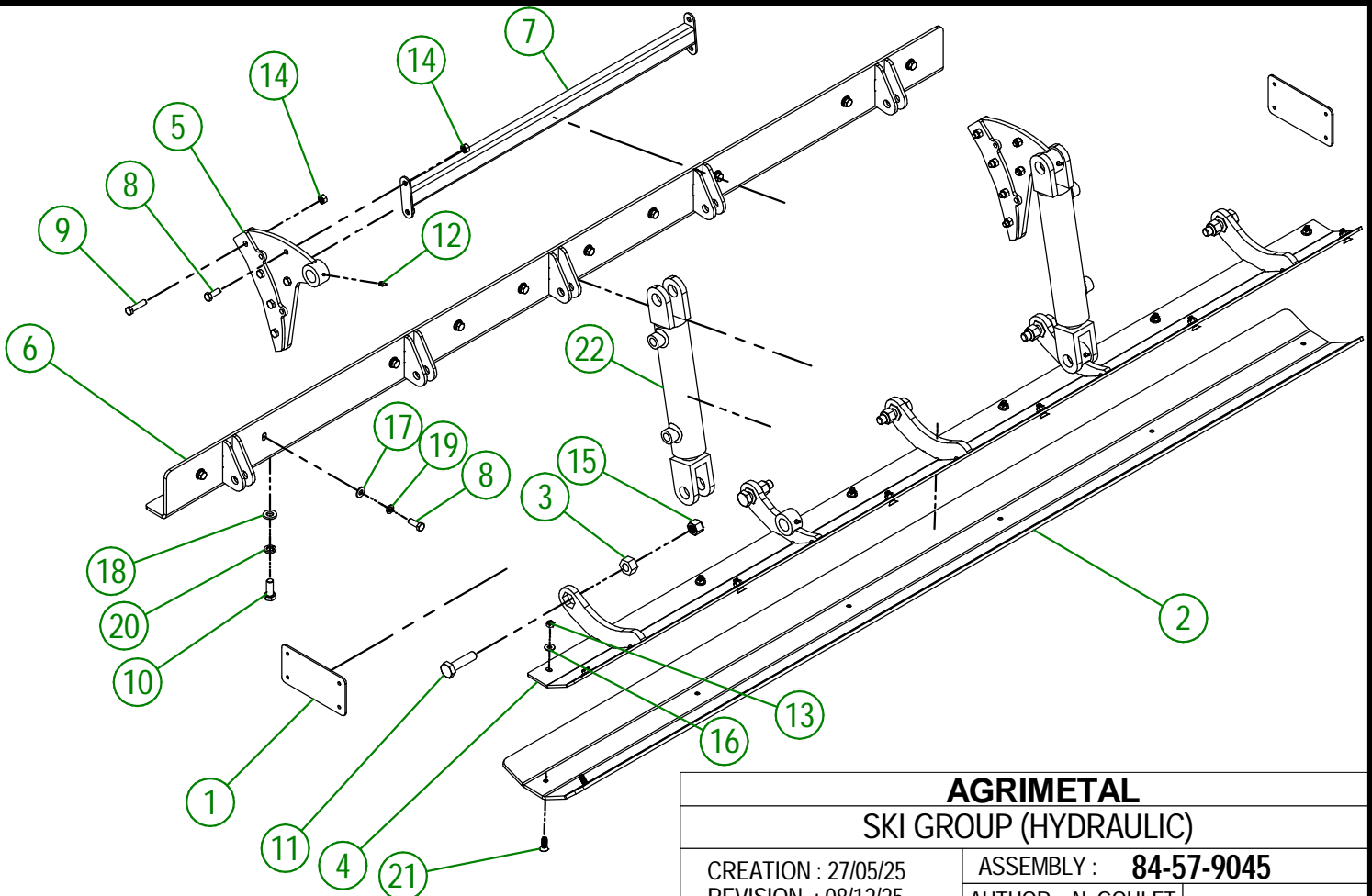

AGRIMETAL
SKI GROUP (HYDRAULIC)

CREATION : 27/05/25
REVISION : 08/12/25

ASSEMBLY : **84-57-9045**
AUTHOR : N. GOULET

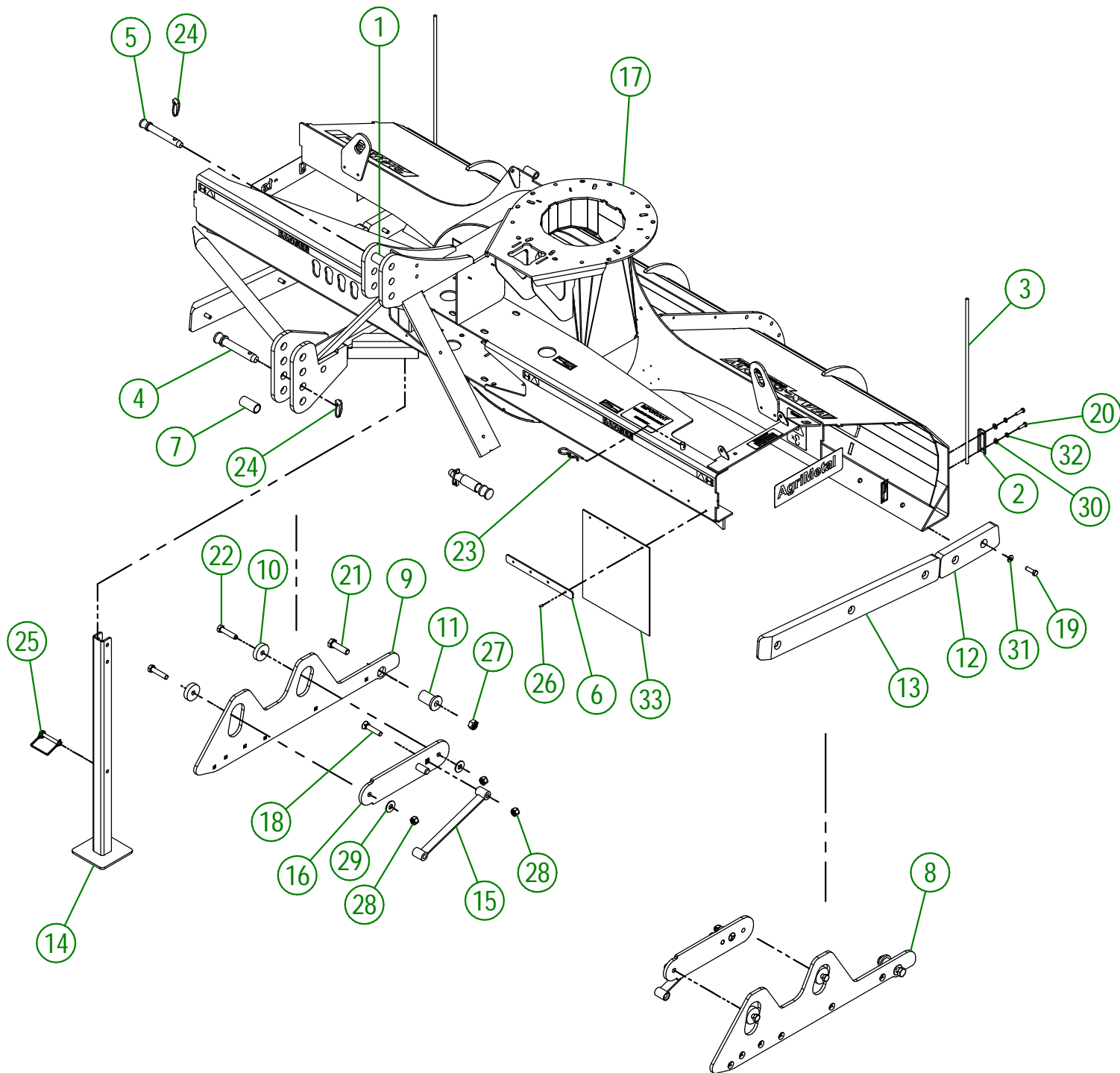

AGRIMETAL
FRAME GROUP

CREATION : 17/01/22
 REVISION : 04/03/26

ASSEMBLY : **84-57-0071**
 AUTHOR : J. Houle

84-57-0071

#	PART #	Qty	TITLE
1	21-09-1205	1	BUSHING
2	39-01-2440	2	GUIDE ROD CLAMP
3	39-42-0600	2	GUIDE ROD
4	48-20-0070	2	3 POINT PIN
5	48-20-0075	1	3 POINT PIN
6	82-01-0970	1	SNOW GUARD BRACE
7	82-13-1300	2	HITCH CONVERSION BUSHING (CATEGORY 2)
8	84-04-2054	1	LEFT FLOATING KNIFE PIVOT
9	84-04-2055	1	RIGHT FLOATING KNIFE PIVOT
10	84-13-2065	4	FLOATING SKATE BUSHING
11	84-13-2076	2	PIVOT BUSHING
12	84-42-0385	2	SIDE PROTECTION
13	84-42-0390	2	SIDE PROTECTION
14	84-50-0090	1	STAND
15	84-50-2005	2	SPRING BLADE
16	84-50-2025	2	SPRING BLADE TENSIONER SUPPORT
17	84-57-0015	1	FRAME
18	NC01-09-0034	2	PLOW BOLT GR5 1/2-13 X 2 1/2" LG
19	NC01-17-0115	10	HEX. BOLT GR2 ZINC 3/8-16 X 1 1/4"
20	NC01-29-0006	4	HEX. BOLT GR5 NF ZINC 1/4-28 X 1 1/2"
21	NC01-33-0397	2	HEX. BOLT GR8 NC ZINC 5/8-11 X 2 1/4"
22	NC01-33-0514	4	HEX. BOLT GR8 ZINC 1/2-13 X 2 1/4"
23	NC01-63-0026	1	COTTER PIN ZC 5/32" X 3"
24	NC01-69-1100	3	LINCH PIN 3/8"
25	NC01-69-1306	1	LOCKING PIN 3/8" X 2 1/2" LG
26	NC01-78-0041	4	POP RIVET STAINLESS STEEL ROD STEEL .187" X .690"
27	NC01-93-0016	2	LOCK NUT ZINC 5/8-11
28	NC01-96-0014	6	NYLON-INSERT LOCKNUT ZINC 1/2-13
29	NC02-22-0012	4	WASHER ZINC 1/2 BOLT = 9/16"Ø X 1 3/8" OD
30	NC02-25-0007	4	WASHER ZINC 0.281 = 9/32
31	NC02-26-1525	10	WASHER INOX .406" D.I. X .815" D.E.
32	NC02-32-0010	4	LOCK WASHER ZINC 1/4"
33	NCI3-15-0315	1	SNOW GUARD

#	PART #	Qty	TITLE
1	NC01-17-0255	2	HEX. BOLT GR2 ZINC 1/2-13 X 3"
2	NC01-96-0014	2	NYLON-INSERT LOCKNUT ZINC 1/2-13
3	NC17-46-0018	4	HANDLE KNOB
4	NC01-17-0119	4	HEX. BOLT GR2 ZINC 3/8-16 X 2 1/4"
5	84-57-0075	1	IMPELLER ACCESS DOOR
6	NC01-69-1100	1	LINCH PIN 3/8"
7	NC02-26-1525	4	WASHER INOX .406" D.I. X .815" D.E.

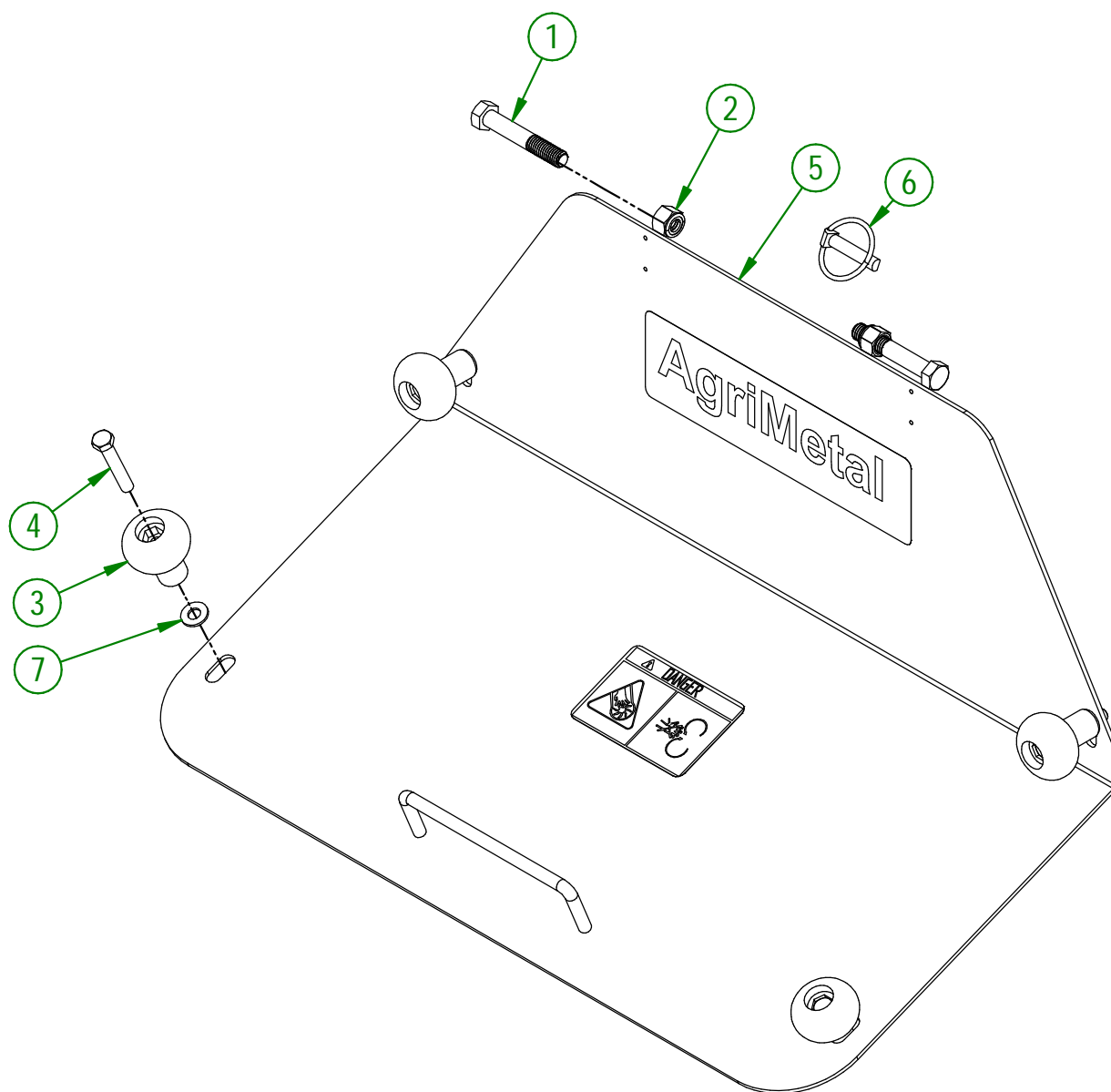

AGRIMETAL	
IMPELLER ACCESS DOOR GROUP	
CREATION : 04/12/17	ASSEMBLY : 84-57-0035
REVISION : 22/12/25	AUTHOR :

82-57-1926

#	PART #	Qty	TITLE
1	82-50-0051	1	IMPELLER
2	NC01-37-0121	2	HEX. BOLT GR8 ZINC 3/8-24 X 2 3/4" LG
3	NC01-94-0011	2	LOCK NUT 3/8-24
4	80-04-0185	1	WASHER
5	NC01-25-0395	1	HEX. BOLT GR5 ZINC 5/8-11 X 1 3/4" LG
6	NC02-32-0016	1	LOCK WASHER ZINC 5/8"

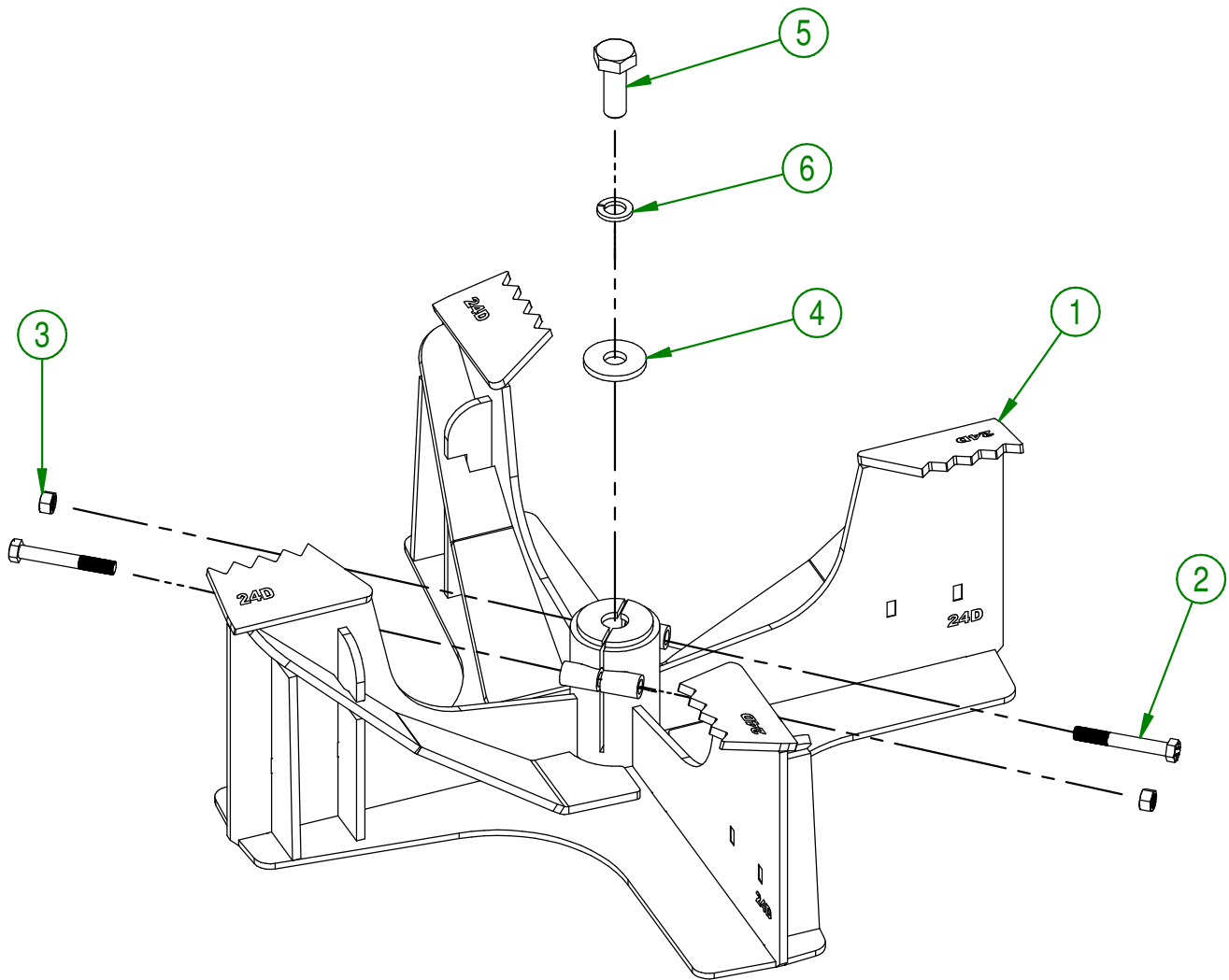

AGRIMETAL	
IMPELLER GROUP	
CREATION : 16/04/18	ASSEMBLY : 82-57-1926
REVISION : 25/06/20	AUTHOR : F.HÉLIE

#	PART #	Qty	TITLE
1	NC14-75-0160	2	FLANGE BEARING 4 HOLES UCF 207-20 X 1 1/4"
2	NC02-25-0011	8	WASHER SAE ZINC 17/32 ID
3	84-50-0580	1	SPIRAL
4	NC01-17-0251	4	HEX. BOLT GR2 ZINC 1/2-13 X 2"
5	NC01-17-0250	4	HEX. BOLT GR2 ZINC 1/2-13 X 1 3/4"
6	NC02-32-0014	8	LOCK WASHER ZINC 1/2"
7	NC02-07-0020	8	HEX. NUT ZINC 1/2-13
8	84-01-3000	1	SPIRAL BEARING SHIM
9	NC14-55-0294	1	60A32H SPROCKET
10	NC01-37-0115	4	HEX. BOLT GR8 ZINC 3/8-24 X 1 1/4
11	NC01-94-0011	4	JAM NUT 3/8-24
12	82-51-0086	1	SHAFT OF THE SPIRAL
13	82-51-0091	1	SHAFT OF THE SPIRAL (SPROCKET)

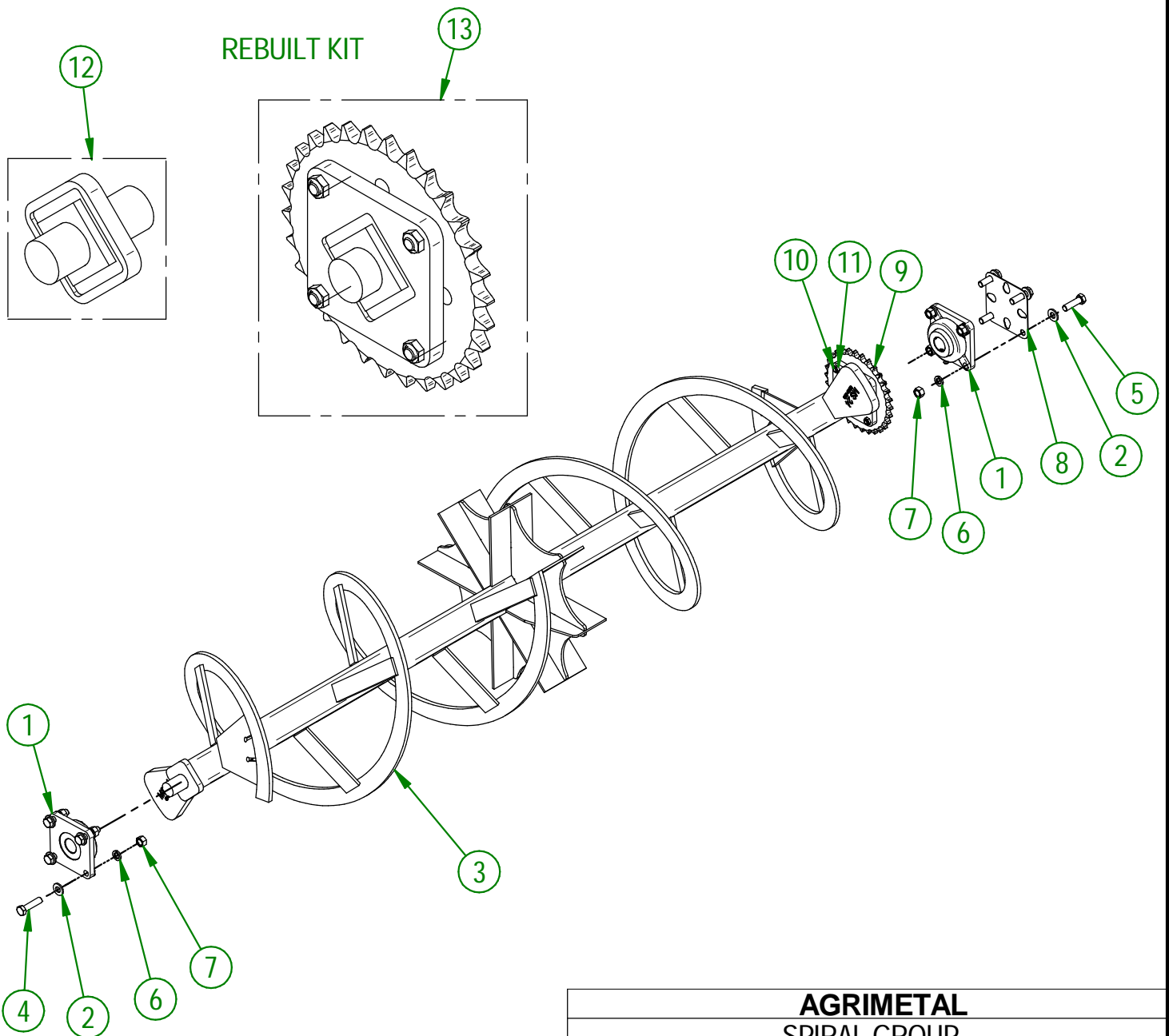

AGRIMETAL
SPIRAL GROUP

CREATION : 04/12/17
REVISION : 09/12/25

ASSEMBLY : **84-57-0025**
AUTHOR : Dessin2

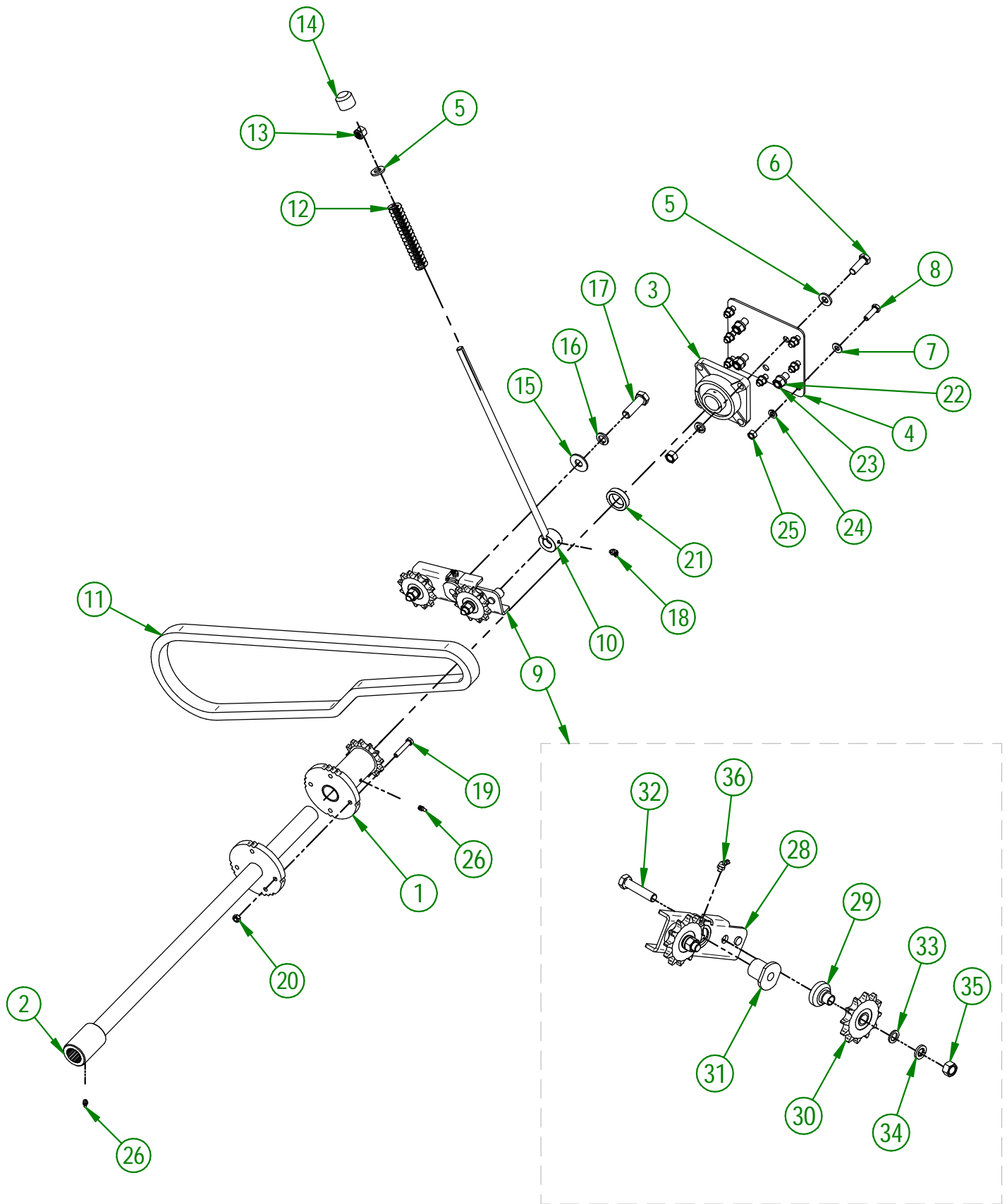

AGRIMETAL	
SPIRAL DRIVE TRAIN GROUP	
CREATION : 10/05/21	ASSEMBLY : 84-57-0032
REVISION : 22/12/25	AUTHOR : G.HUBERDEAU

84-57-0032

#	PART #	Qty	TITLE
1	NC14-55-0327	1	60BI2H SPROCKET
2	84-50-0567	1	SPIRAL DRIVE TRAIN SHAFT
3	NC14-75-0024	1	FLANGE BEARING 4 HOLES UCF207-20 1 1/4" DIA.
4	84-01-0905	1	COUNTER SHAFT BEARING SUPPORT
5	NC02-25-0011	5	WASHER SAE ZINC 17/32 ID
6	NC01-17-0249	4	HEX. BOLT GR2 ZINC 1/2-13 X 1 1/2"
7	NC02-26-1525	7	WASHER INOX .406" D.I. X .815" D.E.
8	NC01-17-0115	7	HEX. BOLT GR2 ZINC 3/8-16 X 1 1/4"
9	80-55-0025	1	CHAIN TENSIONER GROUP
10	84-50-0040	1	THREADED ROD
11	84-37-1000	1	#60 HD CHAIN
12	NC13-86-0053	1	BLUE SPRING 1/2" ID X 1" OD X 6" LG
13	NC01-96-0014	1	NYLON-INSERT LOCKNUT ZINC 1/2-13
14	80-42-0110	1	THREADED ROD CAP
15	NC02-22-0013	1	WASHER ZINC 5/8 ID X 1 1/2 OD
16	NC02-32-0016	1	LOCK WASHER ZINC 5/8"
17	NC01-17-0396	1	HEX. BOLT GR2 ZINC 5/8-11 X 2"
18	NC01-69-0786	1	GREASE FITTING 1/4-28 X 45
19	NC01-17-0063	1	CAP SCREW GR2 NC ZINC 5/16-18 X 1 3/4"
20	NC01-93-0010	1	LOCK NUT ZINC 5/16-18
21	84-21-0001	1	SPIRAL DRIVE TRAIN BUSHING
22	NC02-32-0014	4	LOCK WASHER ZINC 1/2"
23	NC02-07-0020	4	HEX. NUT ZINC 1/2-13
24	NC02-32-0012	7	LOCK WASHER ZINC 3/8"
25	NC02-07-0018	7	HEX. NUT ZINC 3/8-16
26	NC01-69-0785	2	STRAIGHT GREASE FITTING 1/4-28
27	80-57-0160	1	ADJUSTEMENT INDICATOR

80-55-0025

#	PART #	Qty	TITLE
28	80-50-0045	1	CHAIN TENSIONER
29	80-21-0020	2	CHAIN TENSIONER BUSHING (SPROCKET)
30	NC14-55-0295	2	SPROCKET 60A12H
31	80-13-2400	1	CHAIN TENSIONER BUSHING
32	NC01-29-0252	2	HEX. BOLT GR2 ZINC 1/2-20 X 2 1/4" LG
33	NC02-26-1100	2	WASHER SAE ZINC 17/32 ID X 13/16" OD
34	NC02-32-0014	2	LOCK WASHER ZINC 1/2"
35	NC02-10-0020	2	HEX. NUT ZINC 1/2-20
36	NC01-69-0786	1	GREASE FITTING 1/4-28 X 45

AGRIMETAL**SPIRAL DRIVE TRAIN GROUP**

CREATION : 10/05/21

REVISION : 22/12/25

ASSEMBLY : **84-57-0032**

AUTHOR : G.HUBERDEAU

84-57-0062

#	PART #	Qty	TITLE
1	NC02-26-1525	4	WASHER INOX .406" D.I. X .815" D.E.
2	NC01-17-0114	2	HEX. BOLT GR2 ZINC 3/8-16 X 1"
3	NC01-96-0011	2	NYLON NUT 3/8-16
4	84-57-0057	1	CHAIN GUARD

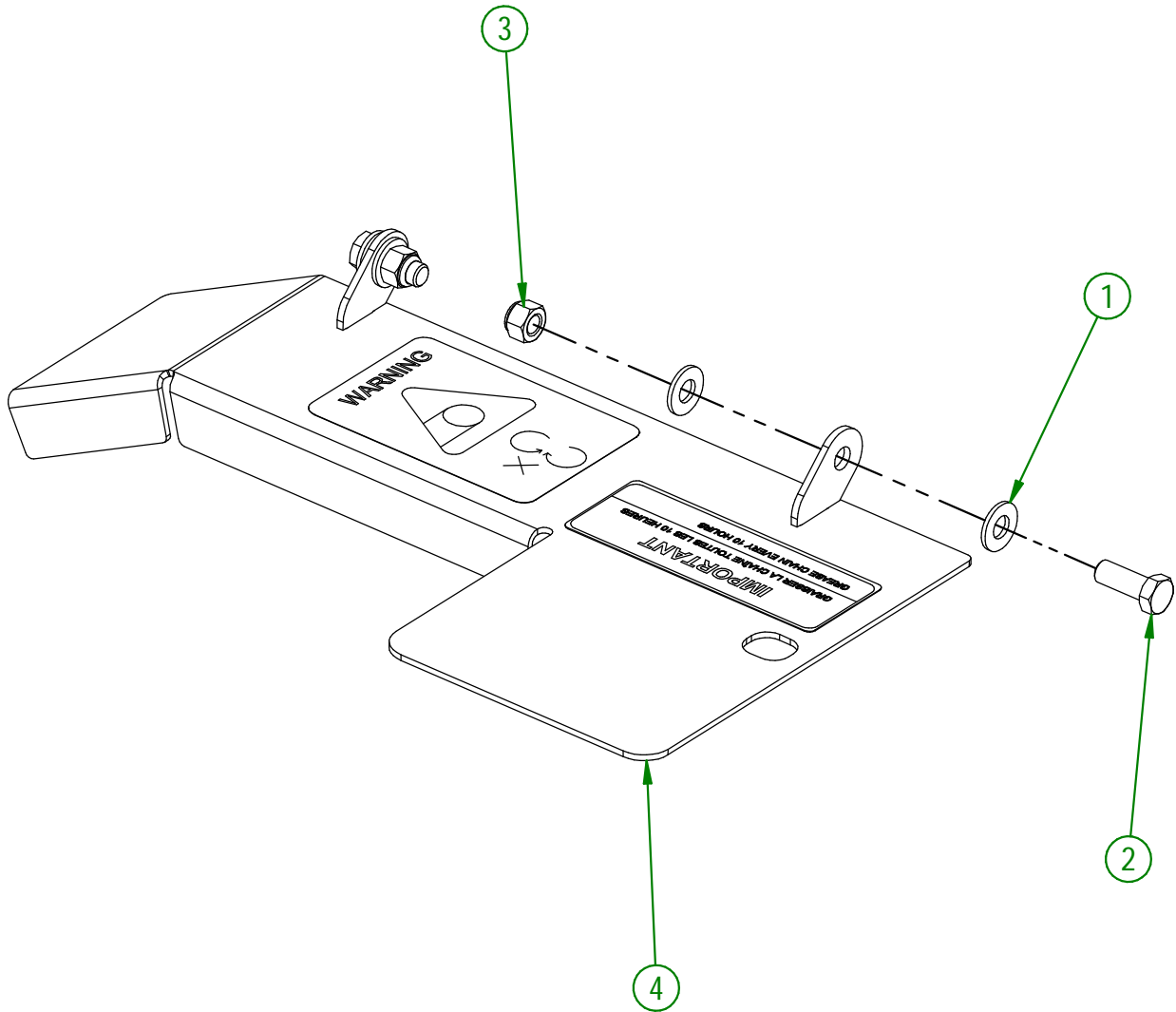

AGRIMETAL	
CHAIN GUARD GROUP	
CREATION : 04/05/21	ASSEMBLY : 84-57-0062
REVISION : 22/12/25	AUTHOR : G.HUBERDEAU

#	PART #	Qty	TITLE
1	84-55-0010	1	GEARBOX
2	80-57-0040	1	PTO GUARD
3	NC02-25-0011	14	WASHER SAE ZINC 17/32 ID
4	NC02-32-0014	12	LOCK WASHER ZINC 1/2"
5	NC01-33-0248	8	HEX. BOLT .GR8 NC ZINC 1/2-13 X 1 1/4"
6	NC01-63-0027	1	HAIRPIN COTTER
7	80-41-0135	1	PTO GUARD STEEL CABLE
8	NC01-64-0005	2	OVAL SLEEVE (ALUMINUM)
9	80-41-0900	1	IMPELLER KEY
10	NCI3-50-0110	1	IMPORTANT/NOTICE PTO POSTER
11	NCI3-25-0019	1	BLACK TIE RAP
12	80-34-0030	1	PTO SHAFT T60
13	84-01-0090	1	PTO GUARD SUPPORT
14	80-04-0485	1	GEARBOX BRACE
15	NC01-33-0249	4	CAP SCREW GR8 NC ZINC 1/2-13 X 1 1/2" LG
16	NC02-07-0020	4	HEX. NUT ZINC 1/2-13
17	80-04-0480	1	GEARBOX BRACE
18	84-04-0660	2	GEARBOX SPACER

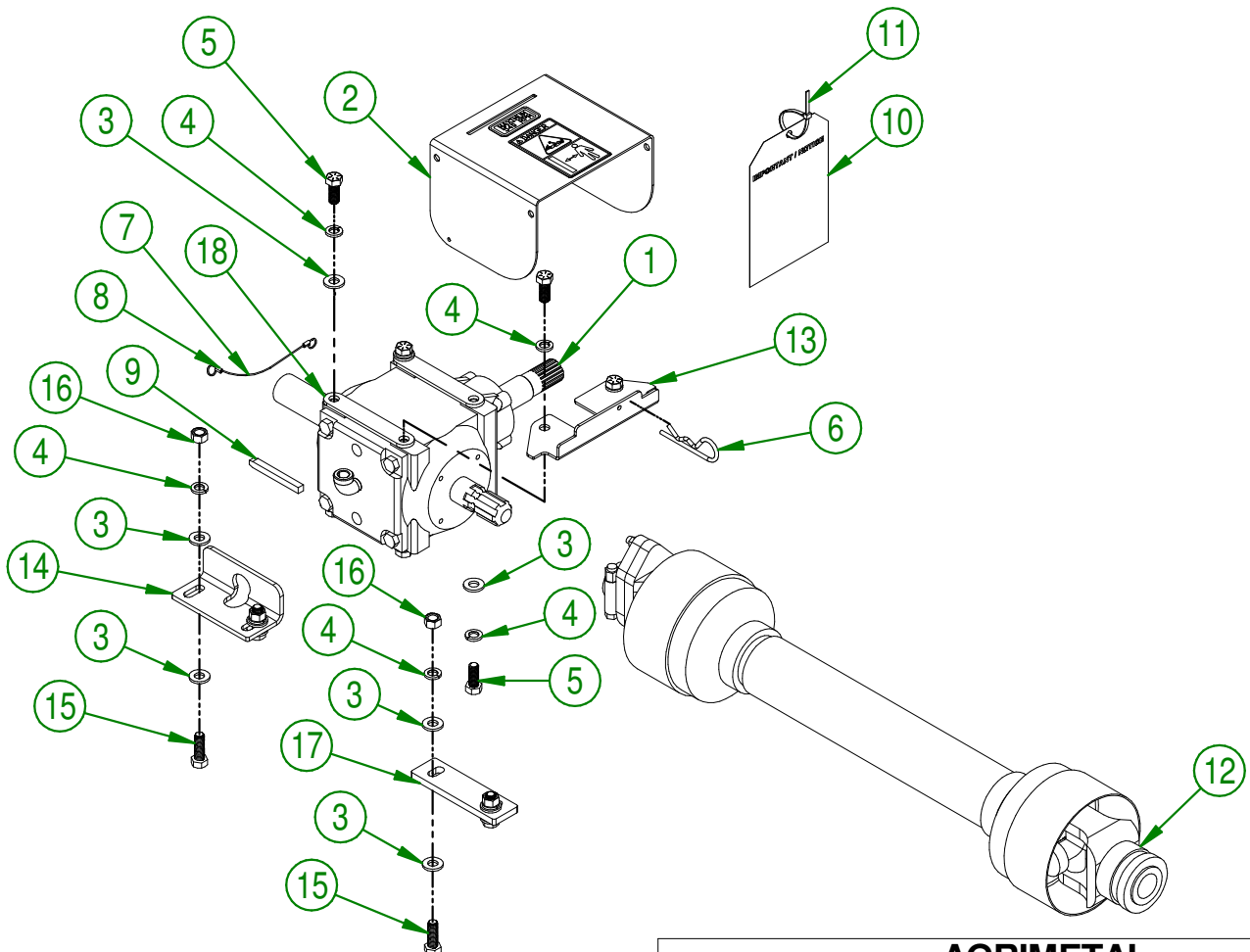

AGRIMETAL
GEARBOX GROUP

CREATION : 05/12/17
REVISION : 11/11/20

ASSEMBLY : **84-57-0080**
AUTHOR : F.HÉLIE

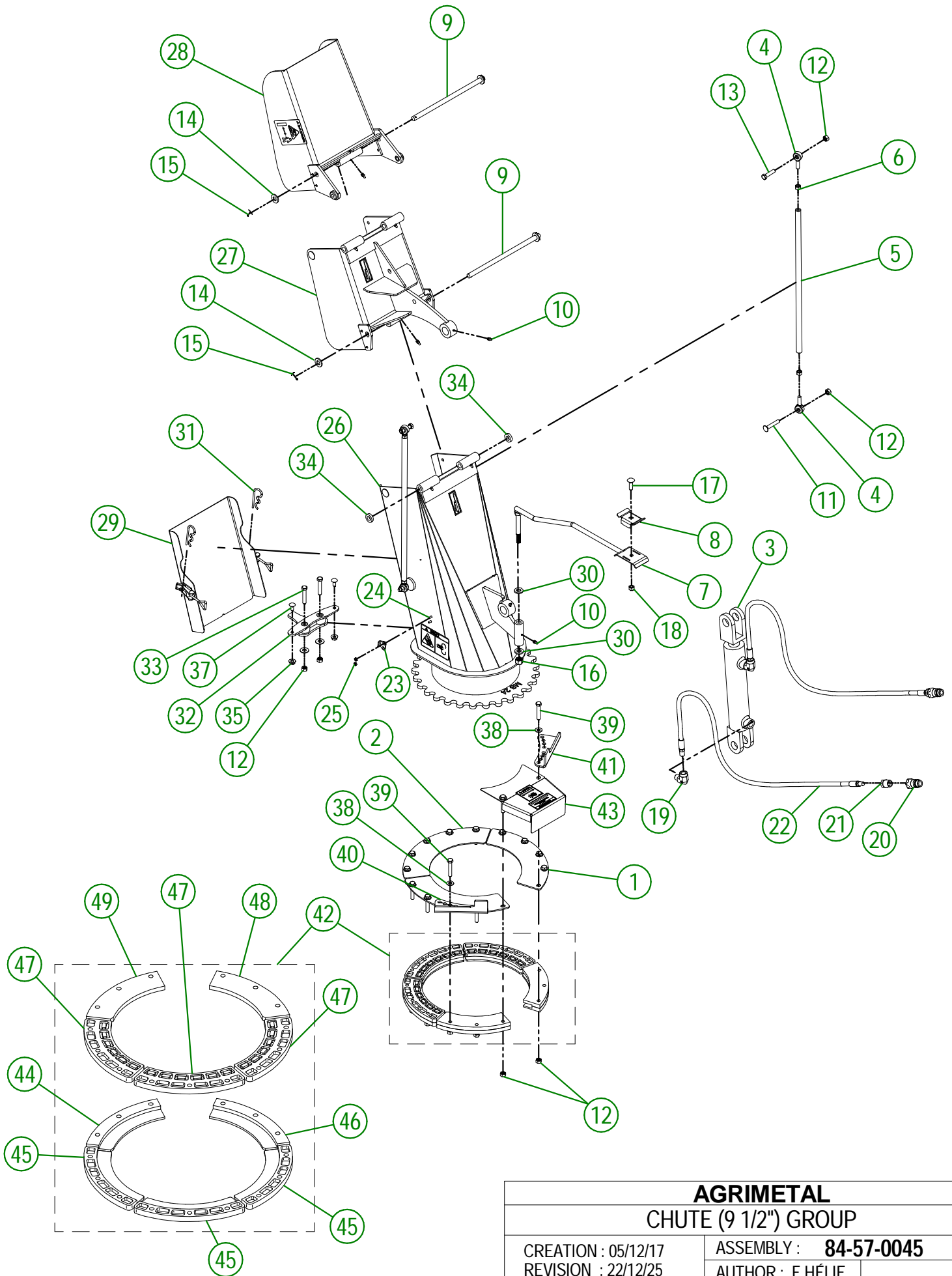

AGRIMETAL
CHUTE (9 1/2") GROUP

CREATION : 05/12/17
 REVISION : 22/12/25

ASSEMBLY : **84-57-0045**
 AUTHOR : F.HÉLIE

84-57-0045

#	PART #	Qty	TITLE
1	82-01-0965	2	BRACE
2	82-01-0955	1	BRACE
3	NC13-45-0404	1	HYDRAULIC CYLINDER 6"
4	NC01-67-0304	4	ROD END 3/8-24
5	48-13-0600	2	CHUTE ROD (DOUBLE)
6	NC02-10-0018	4	NUT 3/8-24
7	48-50-1030	1	HYDRAULIC HOSE SUPPORT
8	48-01-7530	1	HYDRAULIC HOSE SUPPORT
9	82-20-0250	2	PIVOT
10	NC01-69-0785	9	STRAIGHT GREASE FITTING 1/4-28
11	NC01-07-0113	2	CARR. BOLT GR5 ZINC 3/8-16 X 2" LG
12	NC01-93-0011	21	LOCK NUT 3/8-16
13	NC01-25-0116	2	HEX. BOLT GR5 ZINC 3/8-16 X 1 1/2"
14	NC02-25-0011	4	WASHER SAE ZINC 17/32 ID
15	NC01-69-0139	4	COTTER PIN ZINC 1/8" X 3/4"
16	NC01-96-0014	1	NYLON-INSERT LOCKNUT ZINC 1/2-13
17	NC01-07-0110	1	CARR. BOLT GR5 ZINC 3/8-16 X 1 1/4"
18	NC01-96-0011	1	NYLON NUT 3/8-16
19	NC13-45-0038	2	ELBOW 90 3/8 FEM. NPT X 3/8 MALE NPT
20	NC13-45-0369	2	QUICK COUPLER 1/2-14 NPTF
21	NC13-45-0153	2	HEX. REDUCER 1/4 NPT X 1/2 NPT
22	NC17-02-0329	2	HYDRAULIC HOSE (87" LG)
23	NC01-63-0052	2	ADJUSTABLE LATCH (STRIKE)
24	NC02-40-0080	4	MACHINE SCREWS SQUARE SOCKET #10-24 X 1/2" LG
25	NC01-96-0006	4	NYLON NUT ZINC 3/16
26	84-57-0300	1	CHUTE (BOTTOM SECTION)
27	82-57-0311	1	CHUTE (MIDDLE SECTION)
28	82-57-0321	1	CHUTE (TOP SECTION)
29	82-57-0352	1	CHUTE DOOR
30	NC02-25-0011	2	WASHER SAE ZINC 17/32 ID
31	NC01-63-0026	2	COTTER PIN ZC 5/32" X 3"
32	84-50-0600	1	STOPPER
33	NC01-37-0118	2	HEX. BOLT GR8 ZINC 3/8-24 X 2"
34	NC13-15-0334	2	PIVOT WASHER
35	NC02-14-0006	2	HEX. NUT SPECIAL FLANGET NC 5/16-18 B GRADE
36	NC02-22-0010	2	WASHER 13/32" ID
37	NC01-07-0056	2	CARR. BOLT GR5 NC ZINC 5/16-18 X 3/4"
38	NC02-26-1525	15	WASHER INOX .406" D.I. X .815" D.E.
39	NC01-25-0118	15	HEX. BOLT GR5 NC ZINC 3/8-16 X 2"
40	84-04-0180	1	ADJUSTABLE STOPPER
41	84-04-0183	1	ADJUSTABLE STOPPER
42	84-57-1325	1	CHUTE GUIDE GROUP
43	84-57-0500	1	SPROCKET GUARD GROUP "STICKER INCLUDED"

84-57-1325

#	PART #	Qty	TITLE
44	46-42-0107	1	CHUTE GUIDE (UNDER)
45	NC17-46-0030	3	CHUTE GUIDE (UNDER)
46	46-42-0106	1	CHUTE GUIDE (UNDER)
47	NC17-46-0029	3	CHUTE GUIDE (TOP)
48	46-42-0101	1	CHUTE GUIDE (TOP)
49	46-42-0102	1	CHUTE GUIDE (TOP)

#	PART #	Qty	TITLE
1	48-01-7527	1	HYDRAULIC HOSE SUPPORT
2	48-50-1025	1	HYDRAULIC ENGINE SPROCKET
3	80-13-0100	2	HYDRAULIC RESTRICTOR
4	80-45-0000	2	HEX. REDUCER 1/4 NPT X 1/2 NPT
5	81-01-7600	1	HYDRAULIC HOSE SUPPORT
6	NC01-07-0111	1	CARR. BOLT GR5 ZINC 3/8-16 X 1 1/2"
7	NC01-17-0115	2	HEX. BOLT GR2 ZINC 3/8-16 X 1 1/4"
8	NC01-33-0113	4	HEX.BOLT GR8 ZINC 3/8-16 X 3/4"
9	NC01-45-0184	1	HEX. BOLT GR8.8 ZINC 8MM X 20MM
10	NC01-96-0011	1	NYLON NUT 3/8-16
11	NC02-07-0018	2	HEX. NUT ZINC 3/8-16
12	NC02-26-0504	1	WASHER
13	NC02-26-1525	2	WASHER INOX .406" D.I. X .815" D.E.
14	NC02-32-0011	1	LOCK WASHER ZINC 5/16"
15	NC02-32-0012	6	LOCK WASHER ZINC 3/8"
16	NC02-44-0103	2	SET SCREW 5/16-18 X 3/8"
17	NC13-45-0367	2	45°-7/8-14 MALE O RING X 1/2 FEM.TOUR.NPT PT
18	NC13-45-0369	2	QUICK COUPLER 1/2-14 NPTF
19	NC13-45-0378	2	HYDRAULIC RESTRICTOR BUSHING
20	NC14-45-0156	1	HYDRAULIC MOTOR
21	NC17-02-0328	2	HYDRAULIC HOSE (63" LG)
22	NC17-46-0031	1	HYDRAULIC MOTOR BUSHING

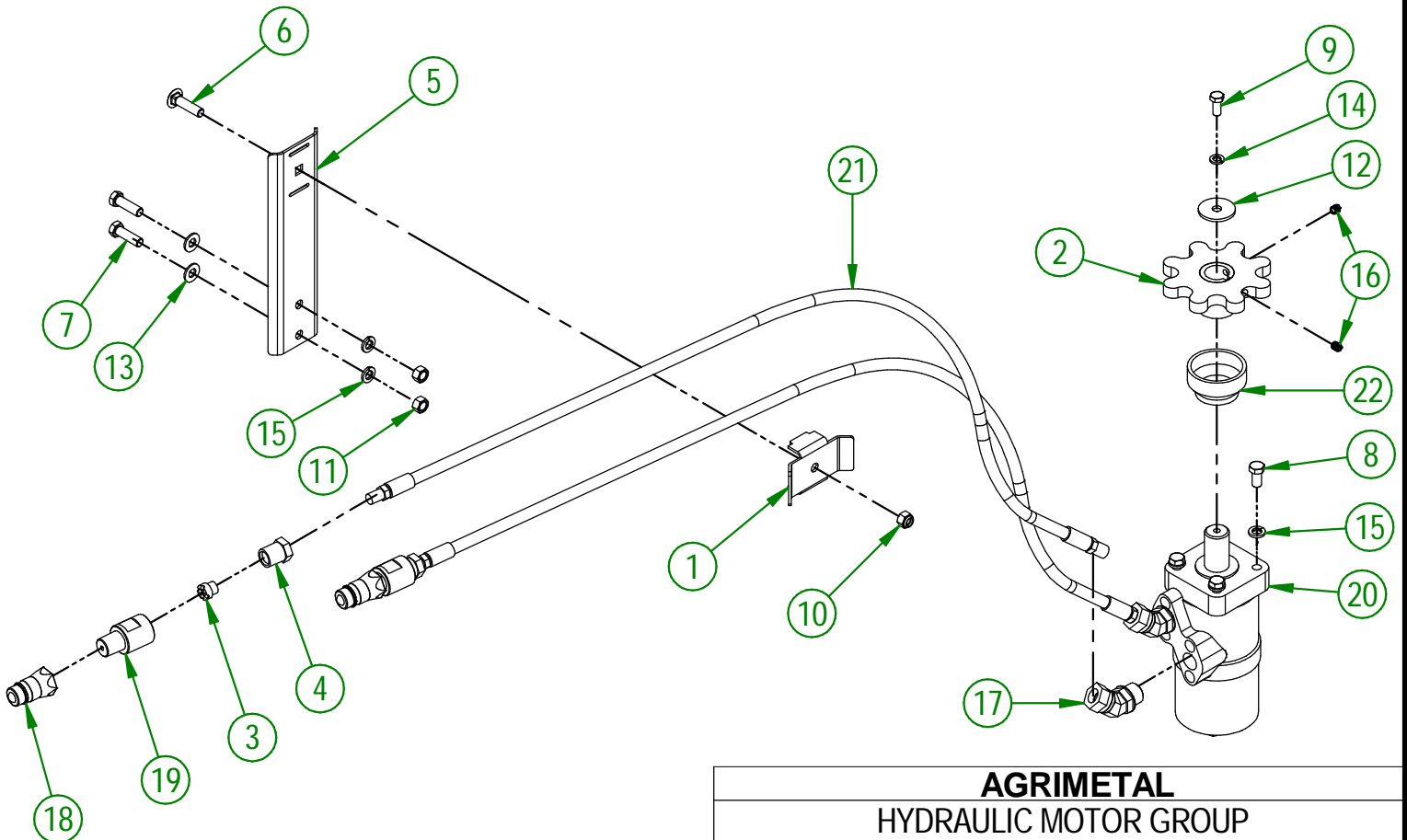
**AGRIMETAL****HYDRAULIC MOTOR GROUP**

CREATION : 05/08/19
 REVISION : 25/03/26

ASSEMBLY : **84-57-0410**
 AUTHOR : F.HÉLIE

#	PART #	Qty	TITLE
1	NCI3-30-0237	1	PLASTIC TUBE FOR OPERATOR'S MANUAL
2	NC02-22-0008	2	WASHER ZINC 5/16"
3	NC01-17-0007	2	HEX. BOLT GR2 ZINC 1/4-20 X 1 1/4"
4	NC01-96-0009	2	NYLON-INSERT LOCKNUT ZINC 1/4-20
5	80-57-0030	1	SET OF 6 SHEAR BOLT WITH NUT
6	84-98-0520	1	ENGLISH OPERATOR'S MANUAL (MS2692-i, MS2482-i)

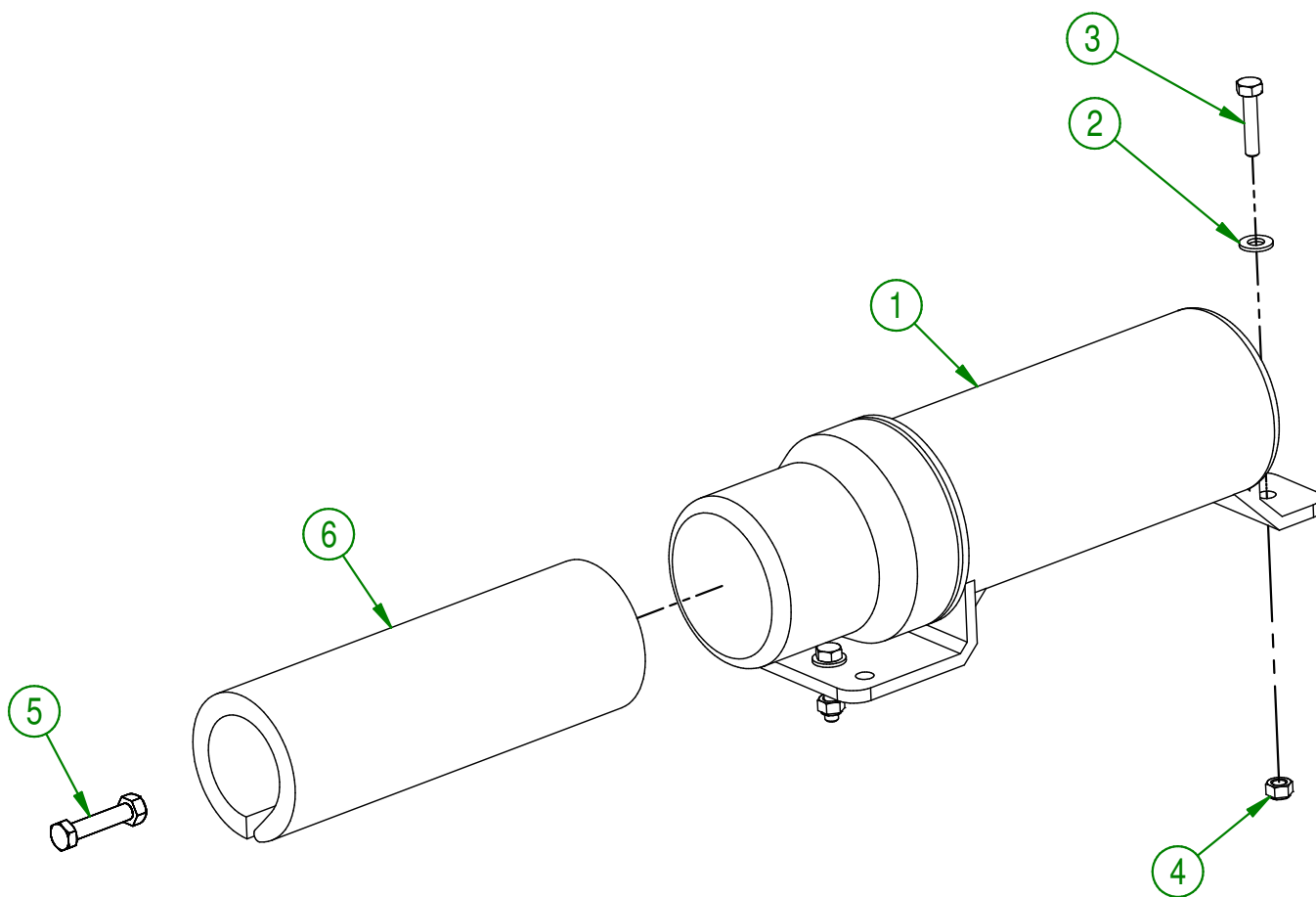

AGRIMETAL	
OPERATOR'S MANUAL TUBE GROUP	
CREATION : 05/12/17	ASSEMBLY : 84-57-0070
REVISION : 06/08/19	AUTHOR : F.HÉLIE

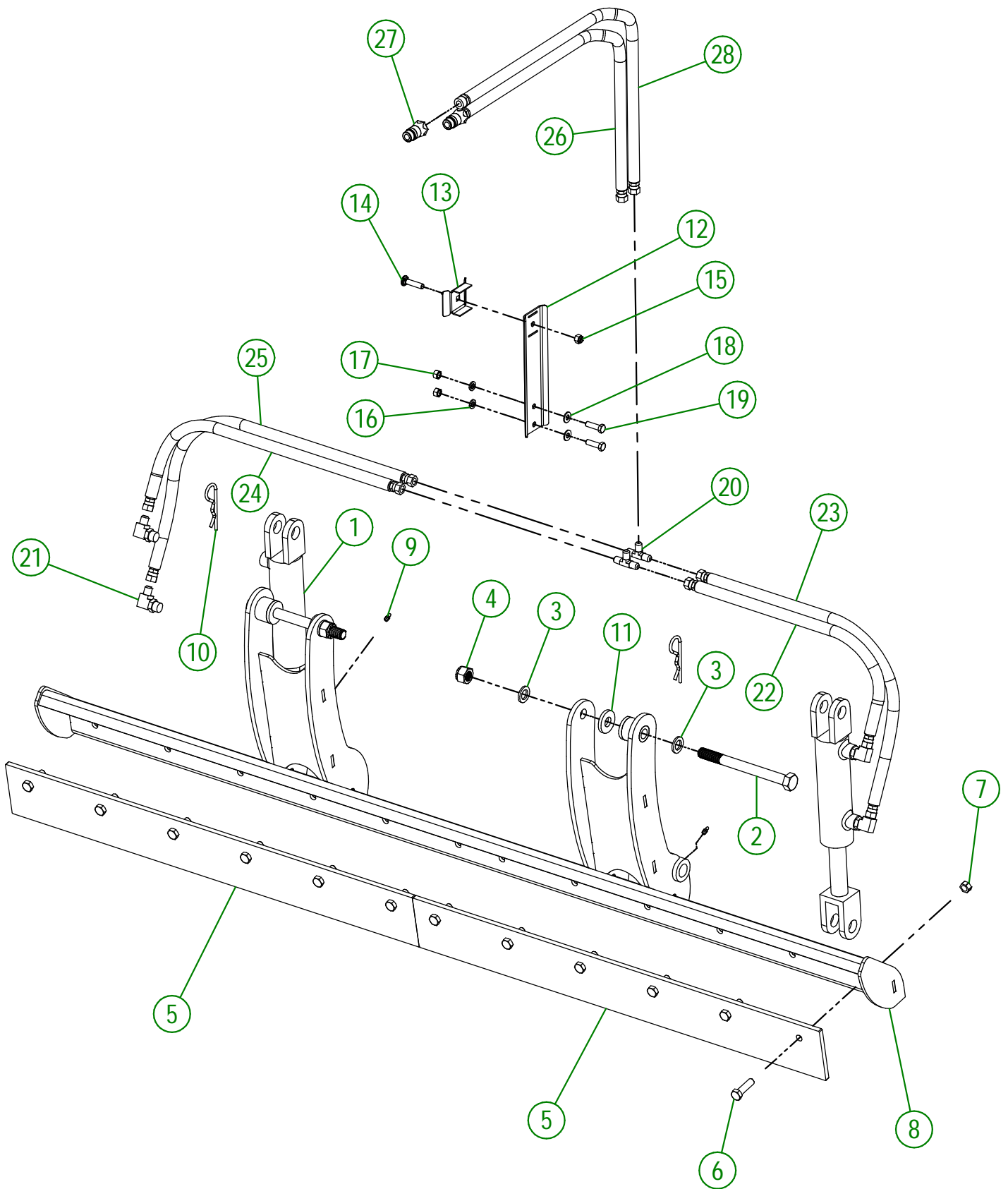

AGRIMETAL		
ICE SCRAPER GROUP		
CREATION : 04/10/22	ASSEMBLY :	84-57-0207
REVISION : 04/10/22	AUTHOR :	J. Houle

84-57-0207

#	PART #	Qty	TITLE
1	NC13-45-0217	2	HYDRAULIC CYLINDER 4" STROKE
2	NC01-33-0486	2	HEX. BOLT GR8 NC ZINC 3/4-10 X 8"
3	01-33-0035	4	FLAT WASHER \varnothing 1 1/4" X \varnothing 49/64" X 10 GA.
4	NC01-96-0017	2	HEX. LOCK NUT NYLO. NC 3/4-10
5	84-20-0091	2	SNOW BLADE
6	NC01-17-0250	12	HEX. BOLT GR2 ZINC 1/2-13 X 1 3/4"
7	NC01-96-0014	12	NYLON-INSERT LOCKNUT ZINC 1/2-13
8	84-50-0206	1	BLADE SUPPORT
9	NC01-69-0785	2	STRAIGHT GREASE FITTING 1/4-28
10	NC01-63-0027	2	HAIRPIN COTTER
11	84-42-0240	4	BLADE WASHER
12	81-01-7600	1	HYDRAULIC HOSE SUPPORT
13	80-01-0020	1	HYDRAULIC HOSE SUPPORT
14	NC01-04-0111	1	CARR. BOLT GR2 ZINC 3/8-16 X 1 1/2"
15	NC01-96-0011	1	NYLON NUT 3/8-16
16	NC02-32-0012	2	LOCK WASHER ZINC 3/8"
17	NC02-07-0018	2	HEX. NUT ZINC 3/8-16
18	01-01-2485	2	FLAT WASHER 14 GA X 13/16"OD X 25/64" ID
19	NC01-17-0115	2	HEX. BOLT GR2 ZINC 3/8-16 X 1 1/4"
20	NC13-45-0289	2	T 3/8 MALE JIC X 3/8 MALE JIC X 3/8 MALE JIC
21	NC13-45-0242	4	90 DEG ELBOW
22	NC17-02-0412	1	HYDRAULIC HOSE 3/8 X 24 1/2" LG
23	NC17-02-0409	1	HYDRAULIC HOSE 3/8 X 29 1/4" LG
24	NC17-02-0409	1	HYDRAULIC HOSE 3/8 X 29 1/4" LG
25	NC17-02-0411	1	HYDRAULIC HOSE 3/8 X 32" LG
26	NC17-02-0410	1	HYDRAULIC HOSE 3/8 X 63"
27	NC13-45-0014	2	QUICK COUPLER 1/2-14 NPTF
28	NC17-02-0410	1	HYDRAULIC HOSE 3/8 X 63" LG.

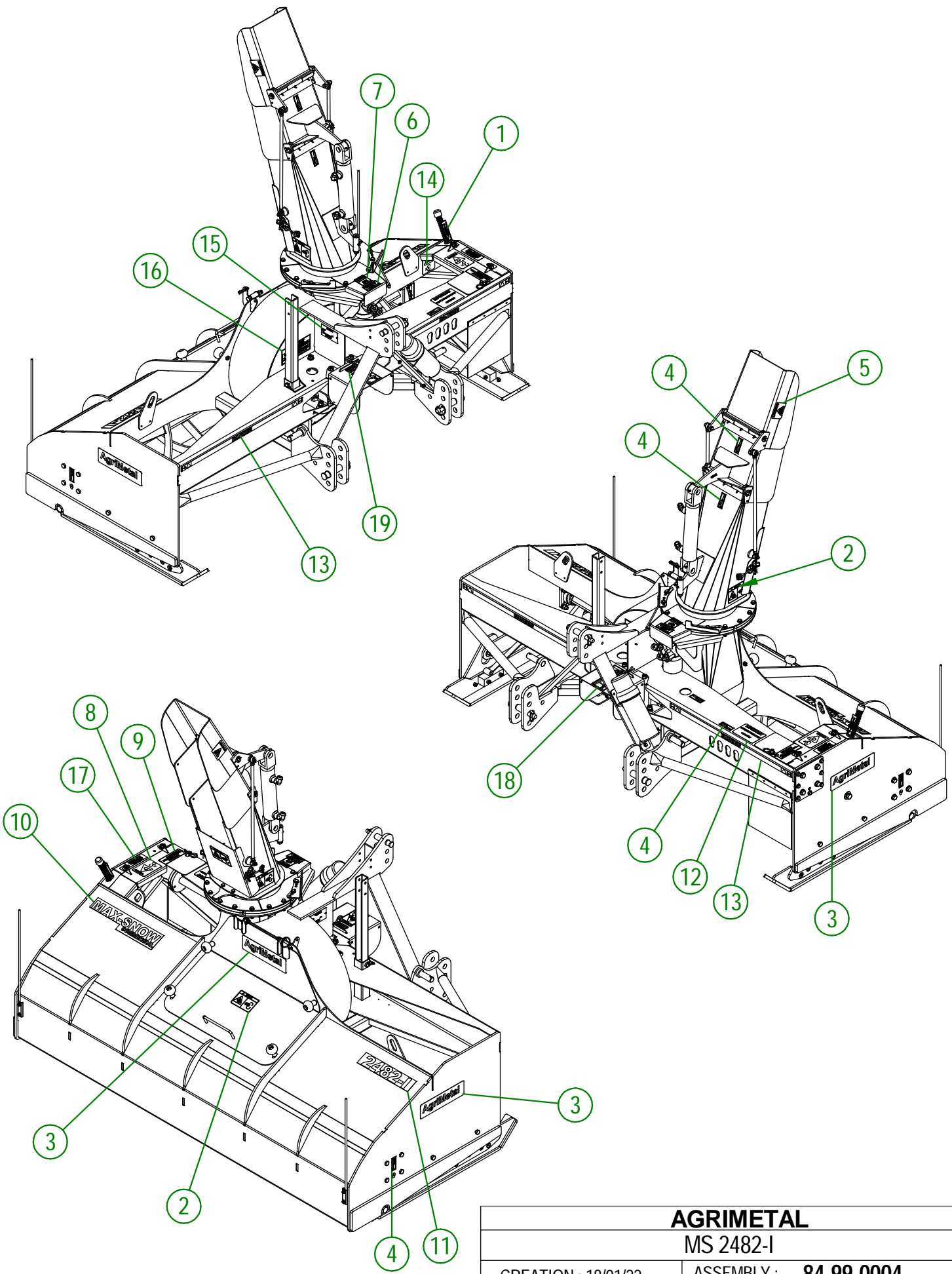

AGRIMETAL	
MS 2482-I	
CREATION : 18/01/22	ASSEMBLY : 84-99-0004
REVISION : 18/01/22	AUTHOR : J. Houle

84-99-0004

#	PART #	Qty	TITLE
1	NC13-33-0344	1	ADJUSTEMENT INDICATOR STICKER
2	NC13-33-0249	4	STICKER DANGER
3	NC13-33-0035	3	STICKER AGRIMETAL
4	NC13-33-0024	6	STICKER GREASE HERE
5	NC13-33-0192	2	STICKER (PROJECTION RISK)
6	NC13-33-0327	1	STICKER END ROTATION ADJUSTMENT
7	NC13-33-0326	1	STICKER DANGER (HAND)
8	NC13-33-0283	1	STICKER DANGER (PERSON AND CHAIN DRIVE)
9	NC13-33-0343	1	GREASE CHAIN EVERY 10 HOURS STICKER
10	NC13-33-0241	1	STICKER MAX-SNOW COMMERCIAL
11	NC13-33-0302	1	STICKER 2482-i
12	NC13-33-0280	1	STICKER SHEAR BOLT
13	NC13-33-0274	2	STICKER DANGER
14	NC13-33-0189	1	STICKER DANGER (PERSON AND CHAIN DRIVE)
15	NC13-50-0086	1	SERIAL NUMBER PLATE
16	NC13-33-0317	1	STICKER GREASE DRIVE LINE TELESCOPIC SHAFT
17	NC13-33-0104	1	STICKER IMPORTANT 4 INCHES 100 MM
18	NC13-33-0187	1	STICKER DANGER (PTO AND PERSON)
19	NC13-33-0005	1	STICKER MAXIMUM 540 RPM