

AgriMetal

PARTS LIST

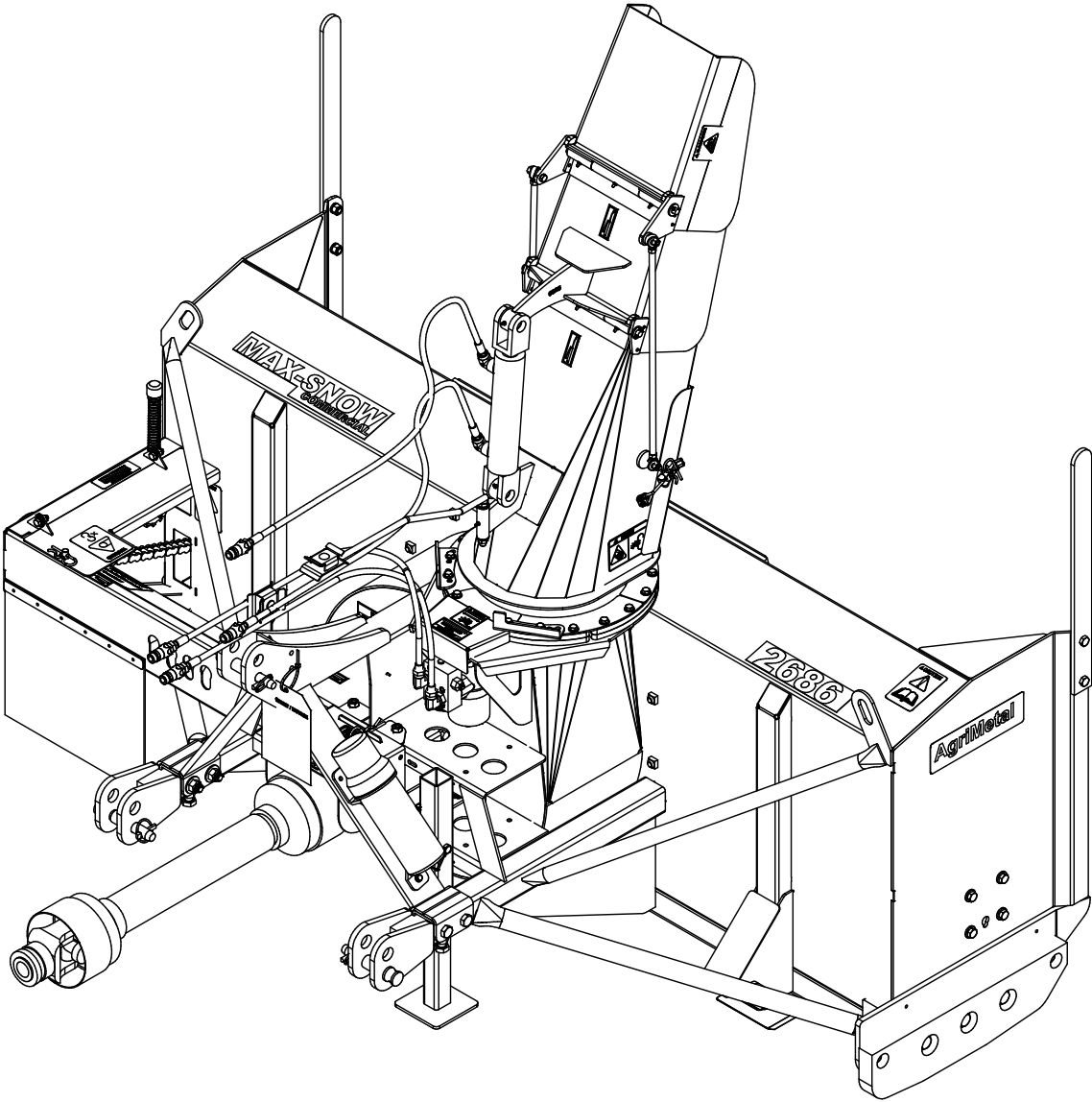

MS 2686

80-57-1207

#	PART #	Qty	TITLE
1	80-42-0155	1	LATERAL HOOF (LEFT)
2	80-42-0157	1	LATERAL HOOF (RIGHT)
3	80-50-1201	2	KNIFE BRACE (TOP)
4	NC01-17-0250	2	HEX. BOLT GR2 ZINC 1/2-13 X 1 3/4"
5	NC01-17-0251	2	HEX. BOLT GR2 ZINC 1/2-13 X 2"
6	NC01-17-0394	6	HEX. BOLT GR2 ZINC 5/8-11 X 1 1/2"
7	NC01-25-0247	8	HEX. BOLT GR5 ZINC 1/2-13 X 1" LG
8	NC01-93-0014	22	LOCK NUT ZINC 1/2-13
9	NC02-22-0014	6	WASHER
10	NC02-25-0011	4	WASHER SAE ZINC 17/32 ID
11	NC02-32-0014	8	LOCK WASHER ZINC 1/2"
12	NC02-48-0548	18	FLAT HEAD SOCKET CAP SCREW STAINLESS 1/2-13 X 2"
13	80-57-1014	1	SET KNIFE (LEFT)
14	80-57-1015	1	SET KNIFE (RIGHT)
15	80-57-57-1022	1	SET OF KNIVES (UHMW)

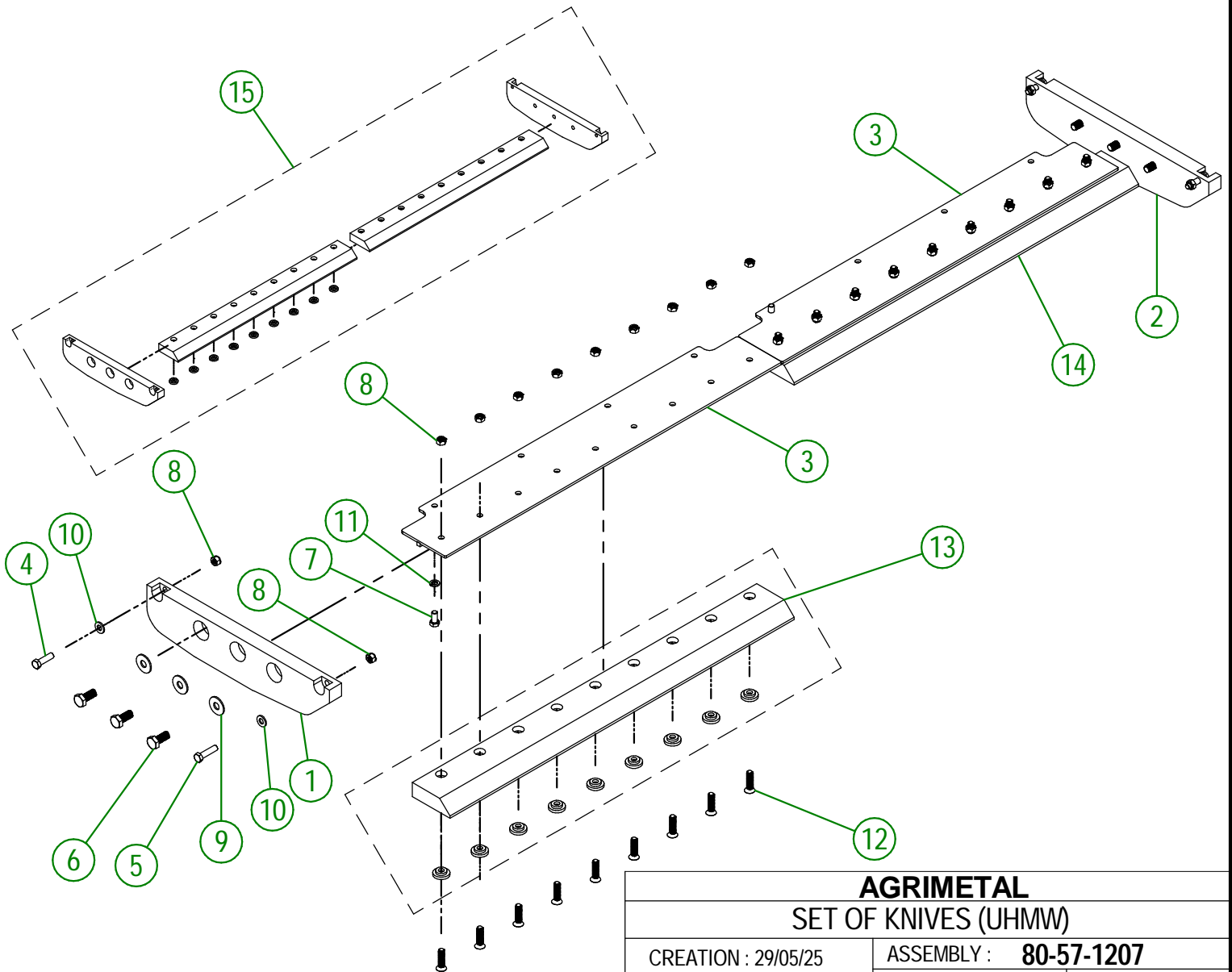

AGRIMETAL
SET OF KNIVES (UHMW)

CREATION : 29/05/25
 REVISION : 18/12/25

ASSEMBLY : **80-57-1207**
 AUTHOR : N. GOULET

80-57-1200

#	PART #	Qty	TITLE
1	80-50-0085	2	LATERAL SKATE (#450 HARDNESS STEEL)
2	80-50-0055	2	ADJUSTABLE SKATE (STEEL)
3	NC02-48-0586	4	FLAT HEAD SOCKET CAP SCREW 5/8-11 X 1" LG
4	80-57-0075	2	KNIFE (#450 HARDNESS STEEL) GROUP (BOLTS AND NUTS INCLUDED)
5	NC01-25-0481	2	HEX. BOLT GR5 NC 3/4-10 X 5"
6	NC01-96-0017	2	HEX. LOCK NUT NYLO. NC 3/4-10

80-57-0075

#	PART #	Qty	TITLE
7	NC01-09-0029	5	PLOW BOLT GR5 1/2-13 X 1 1/4" LG
8	NC01-93-0014	5	LOCK NUT ZINC 1/2-13

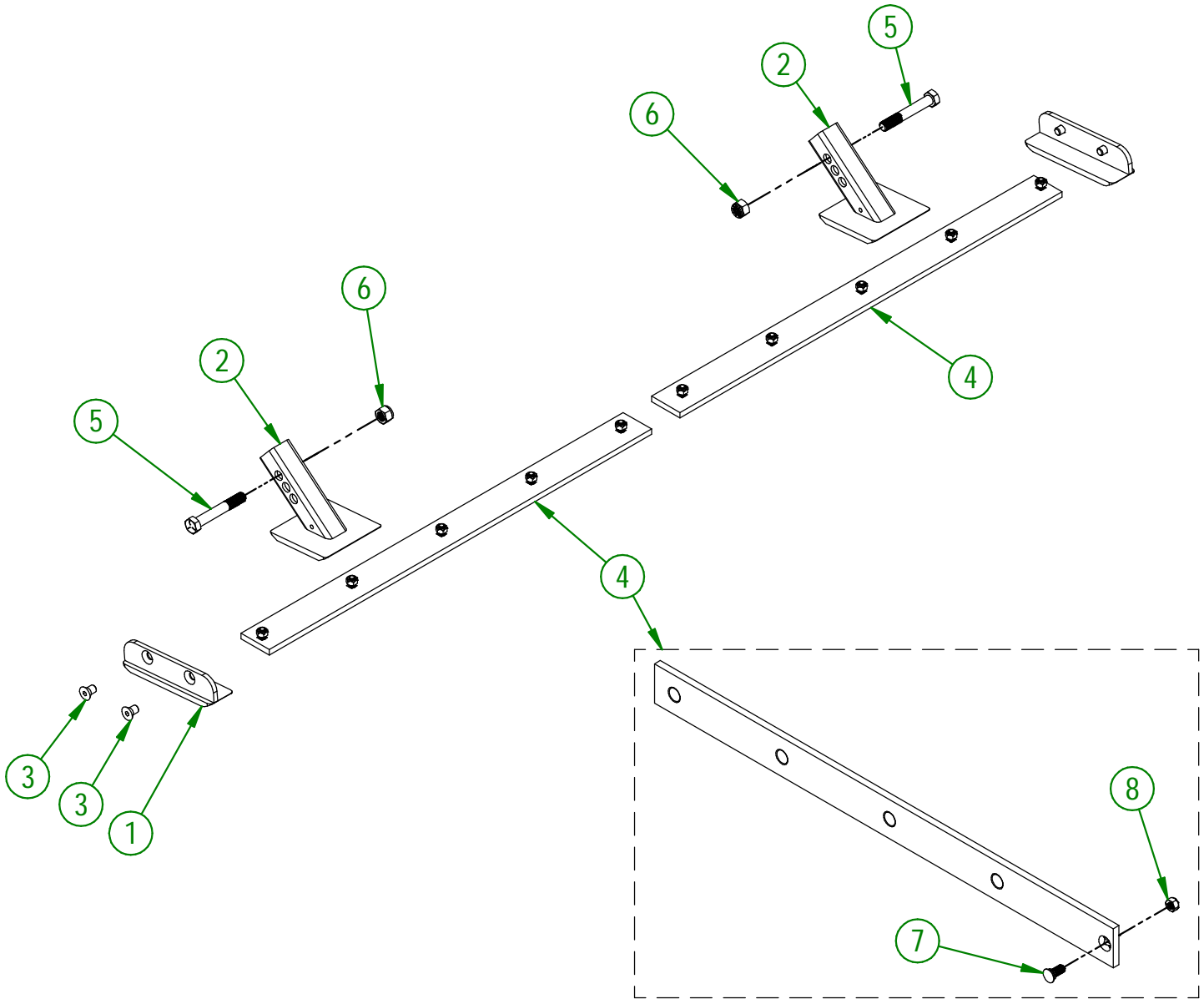

AGRIMETAL	
SET OF KNIVES (#450 HARDNESS STEEL)	
CREATION : 26/01/22	ASSEMBLY : 80-57-1200
REVISION : 20/05/25	AUTHOR : Dessin2

80-57-1210

#	PART #	Qty	TITLE
1	80-50-0087	2	LATERAL SKATE (STAINLESS STEEL)
2	80-50-0058	2	ADJUSTABLE SKATE (STAINLESS STEEL)
3	NC02-48-0586	4	FLAT HEAD SOCKET CAP SCREW 5/8-11 X 1" LG
4	80-57-0080	2	KNIFE (STAINLESS STEEL) GROUP (BOLTS AND NUTS INCLUDED)
5	NC01-25-0481	2	HEX. BOLT GR5 NC 3/4-10 X 5"
6	NC01-96-0017	2	HEX. LOCK NUT NYLO. NC 3/4-10

80-57-0080

#	PART #	Qty	TITLE
7	NC01-93-0014	9	LOCK NUT ZINC 1/2-13
8	NC02-48-0545	9	FLAT HEAD SOCKET CAP SCREW 1/2"-13 X 1 1/4" (STAINLESS STEEL)

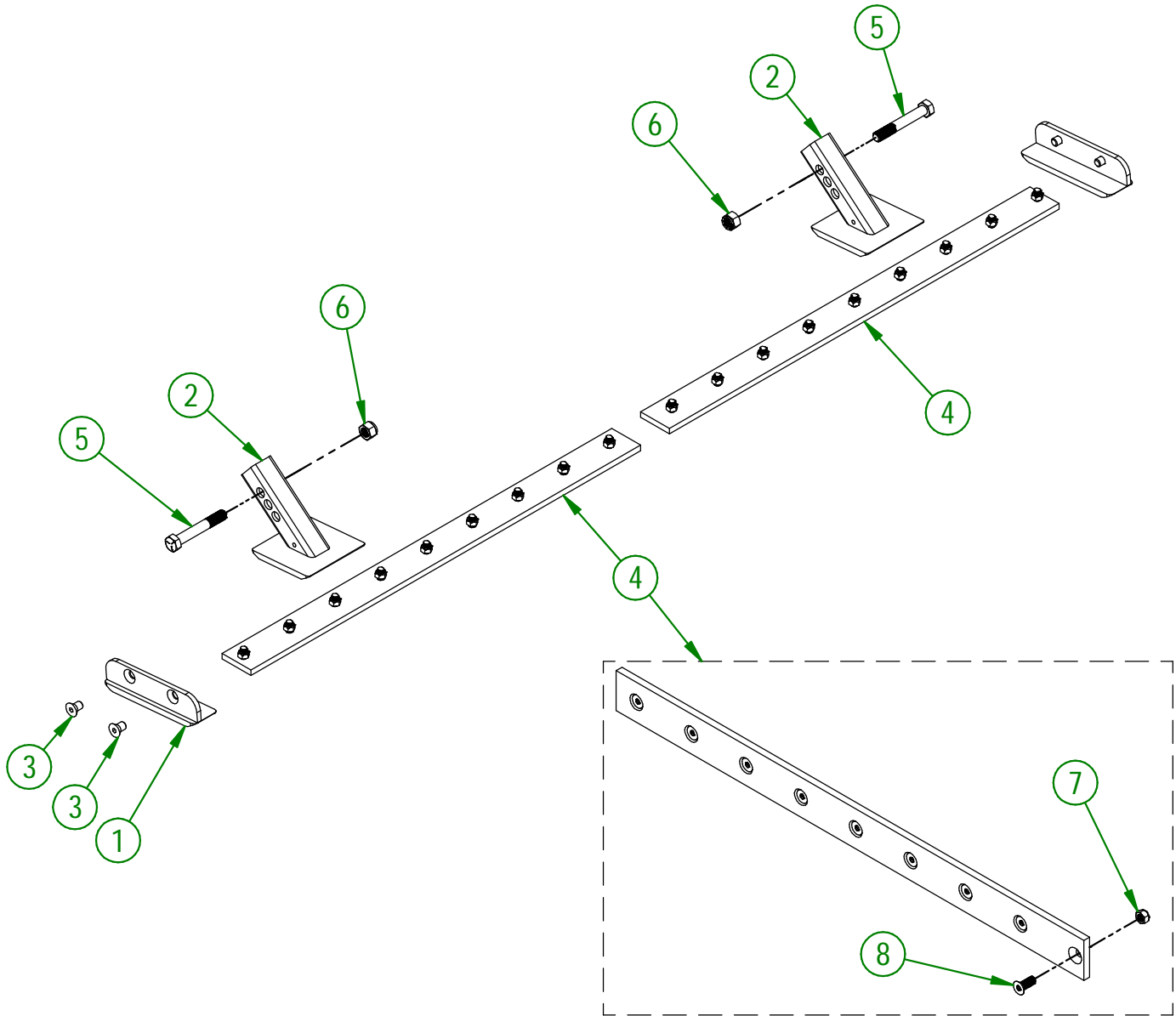

AGRIMETAL	
SET OF KNIVES (STAINLESS STEEL)	
CREATION : 26/01/22	ASSEMBLY : 80-57-1210
REVISION : 20/05/25	AUTHOR : Dessin2

#	PART #	Qty	TITLE
1	48-05-2105	2	LATERAL CUTTER BLADES
2	NC01-25-0248	4	HEX. BOLT GR5 ZINC 1/2-13 X 1 1/4"
3	NC02-32-0014	4	LOCK WASHER ZINC 1/2"
4	NC02-07-0020	4	HEX. NUT ZINC 1/2-13

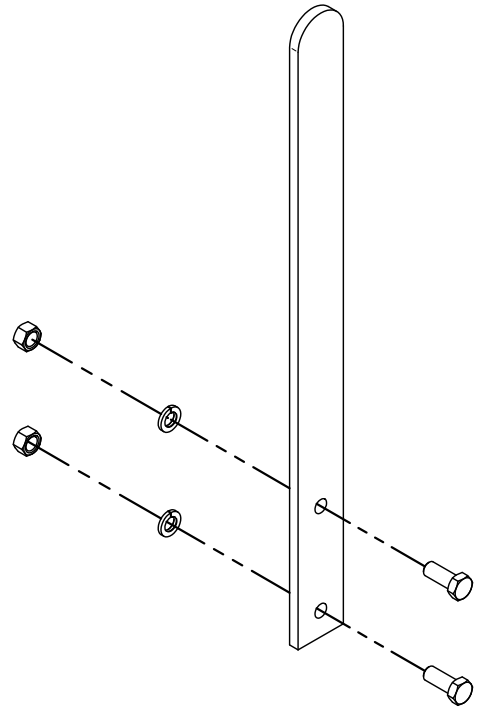
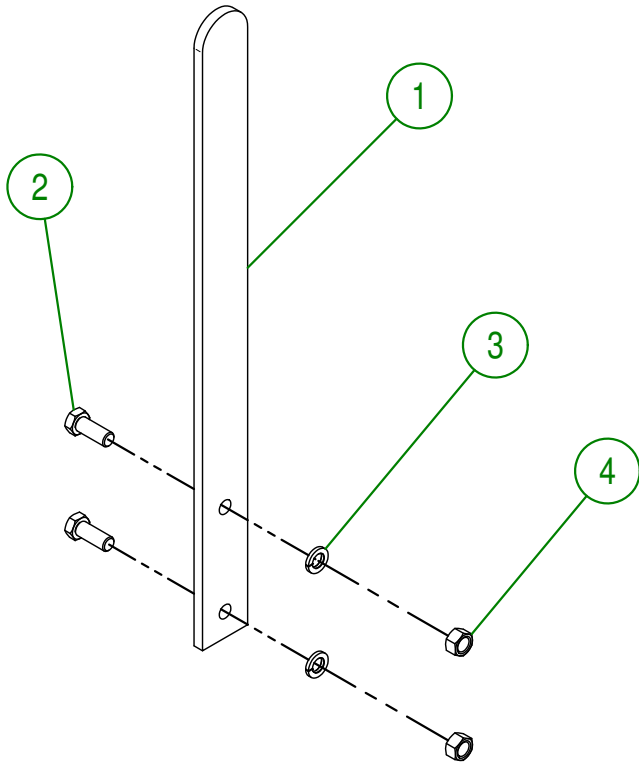

AGRIMETAL	
LATERAL CUTTER BLADES	
CREATION : 24/11/17	ASSEMBLY : 48-57-1235
REVISION : 22/10/18	AUTHOR : J. Houle Page 4 de 20

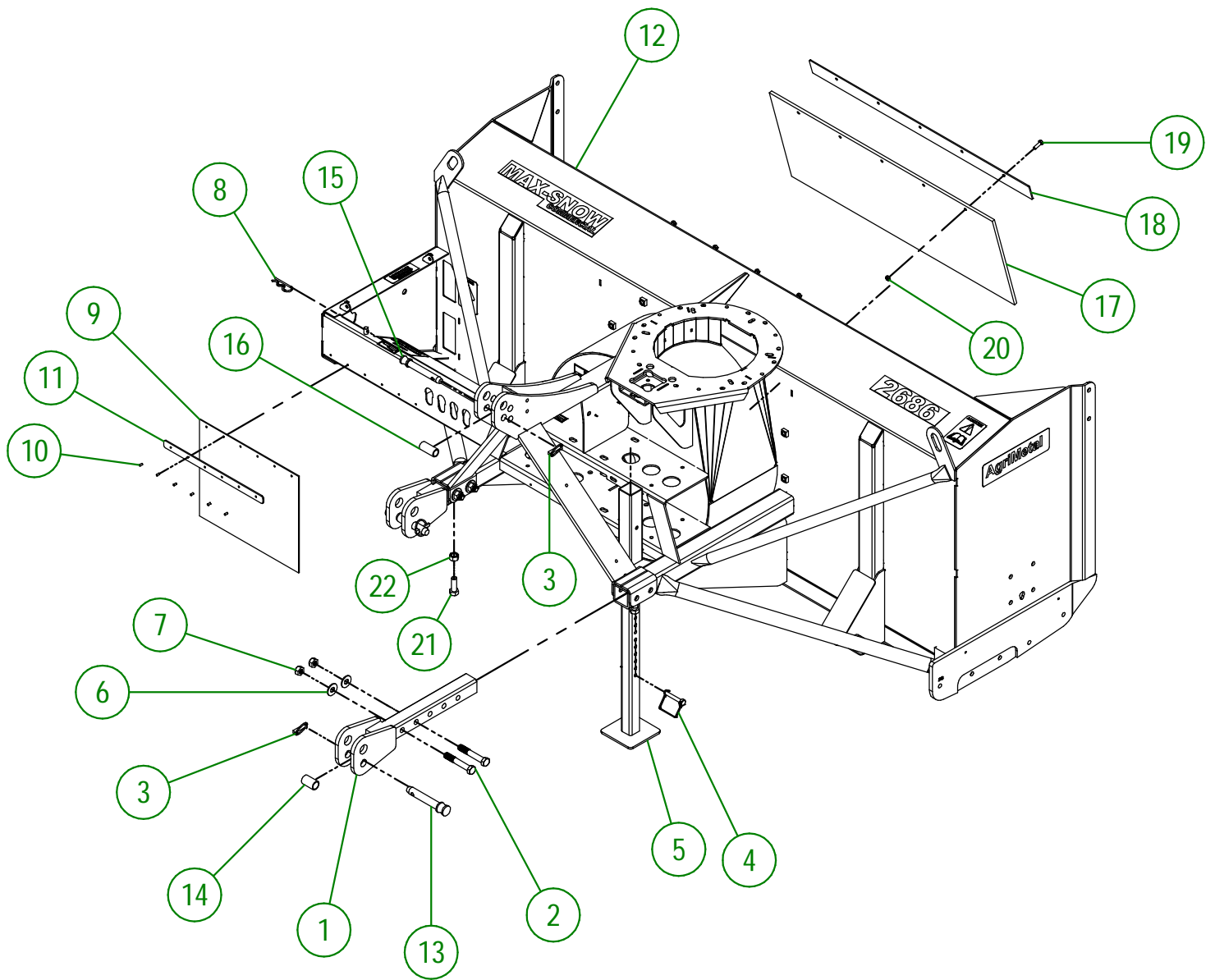

AGRIMETAL
FRAME GROUP

CREATION : 26/01/22
 REVISION : 05/01/26

ASSEMBLY : **80-57-1440**
 AUTHOR : Dessin2

80-57-1440

#	PART #	Qty	TITLE
1	80-50-5020	2	3 POINTS HITCH
2	NC01-33-0404	4	HEX. BOLT GR8 ZINC 5/8-11 X 4" LG
3	NC01-69-1100	3	LINCH PIN 3/8"
4	NC01-69-1306	1	LOCKING PIN 3/8" X 2 1/2" LG
5	80-50-0093	1	STAND
6	NC02-22-0013	4	WASHER ZINC 5/8 ID X 1 1/2 OD
7	NC01-93-0016	4	LOCK NUT ZINC 5/8-11
8	NC01-63-0026	1	COTTER PIN ZC 5/32" X 3"
9	NC13-15-0300	1	SNOW GUARD
10	NC01-78-0041	6	POP RIVET STAINLESS STEEL ROD STEEL .187" X .690"
11	80-01-1075	1	SNOW GUARD BRACE
12	80-57-1000	1	FRAME
13	48-20-0070	2	3 POINT PIN
14	80-13-0105	2	BUSHING
15	48-20-0075	1	3 POINT PIN
16	21-09-1205	1	BUSHING
17	NC13-15-0349	1	RUBBER
18	80-57-0060	1	RUBBER REINFORCEMENT
19	NC01-17-0060	5	HEX. BOLT GR2 ZINC 5/16-18 X 1"
20	NC01-93-0010	5	LOCK NUT ZINC 5/16-18
21	NC01-17-0395	2	HEX. BOLT GR2 ZINC 5/8-11 X 1 3/4"
22	NC02-07-0022	2	HEX. NUT ZINC 5/8-11

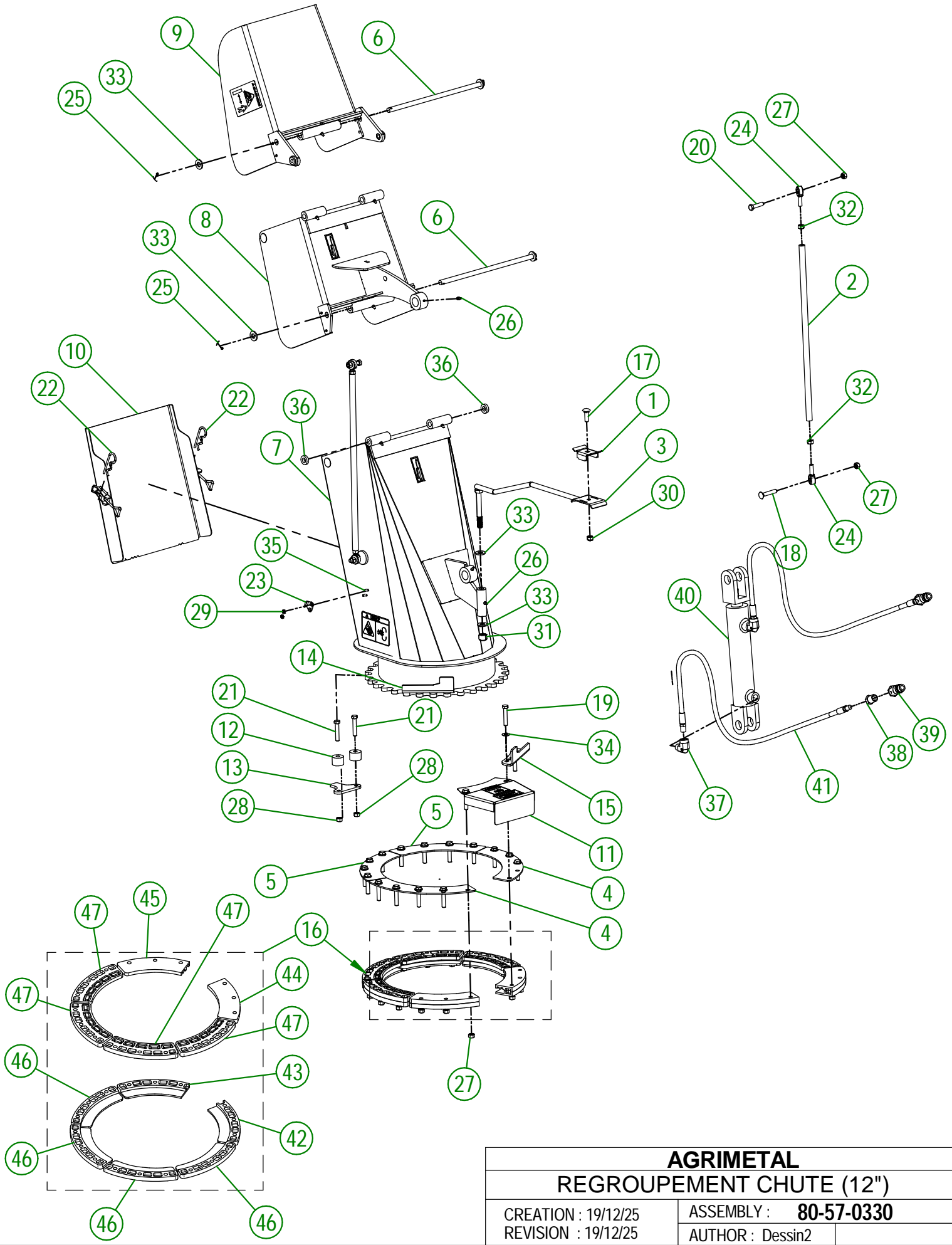

80-57-0330

#	PART #	Qty	TITLE
1	48-01-7530	1	HYDRAULIC HOSE SUPPORT
2	48-13-0600	2	CHUTE ROD (DOUBLE)
3	48-50-1030	1	HYDRAULIC HOSE SUPPORT
4	80-01-1010	2	BRACE
5	80-01-1015	2	BRACE
6	80-20-0260	2	PIVOT
7	80-57-0303	1	CHUTE (BOTTOM SECTION)
8	80-57-0312	1	CHUTE (MIDDLE SECTION)
9	80-57-0322	1	CHUTE (TOP SECTION)
10	80-57-0353	1	CHUTE DOOR
11	80-57-0550	1	SPROCKET GUARD GROUP "STICKER INCLUDED"
12	81-21-0040	2	ADJUSTABLE STOPPER SPACER
13	84-04-0170	1	STOPPER
14	84-04-0175	1	ADJUSTABLE STOPPER
15	84-04-0177	1	ADJUSTABLE STOPPER
16	84-57-1330	1	GUIDE CHUTE GROUP
17	NC01-04-0110	1	CARR. BOLT GR2 ZINC 3/8-16 X 1 1/4"
18	NC01-07-0113	2	CARR. BOLT GR5 ZINC 3/8-16 X 2" LG
19	NC01-17-0118	18	HEX. BOLT GR2 ZINC 3/8-16 X 2"
20	NC01-25-0116	2	HEX. BOLT GR5 ZINC 3/8-16 X 1 1/2"
21	NC01-37-0118	2	HEX. BOLT GR8 ZINC 3/8-24 X 2"
22	NC01-63-0026	2	COTTER PIN ZC 5/32" X 3"
23	NC01-63-0052	2	ADJUSTABLE LATCH (STRIKE)
24	NC01-67-0304	4	ROD END 3/8-24
25	NC01-69-0139	4	COTTER PIN ZINC 1/8" X 3/4"
26	NC01-69-0785	9	STRAIGHT GREASE FITTING 1/4-28
27	NC01-93-0011	22	LOCK NUT 3/8-16
28	NC01-94-0011	2	LOCK NUT 3/8-24
29	NC01-96-0006	4	NYLON NUT ZINC 3/16
30	NC01-96-0011	1	NYLON NUT 3/8-16
31	NC01-96-0014	1	NYLON-INSERT LOCKNUT ZINC 1/2-13
32	NC02-10-0018	4	NUT 3/8-24
33	NC02-25-0011	6	WASHER SAE ZINC 17/32 ID
34	NC02-26-1525	18	WASHER INOX .406" D.I. X .815" D.E.
35	NC02-40-0080	4	MACHINE SCREWS SQUARE SOCKET #10-24 X 1/2" LG
36	NC13-15-0334	2	PIVOT WASHER
37	NC13-45-0038	2	ELBOW 90 3/8 FEM. NPT X 3/8 MALE NPT
38	NC13-45-0153	2	HEX. REDUCER 1/4 NPT X 1/2 NPT
39	NC13-45-0369	2	QUICK COUPLER 1/2-14 NPTF
40	NC13-45-0404	1	HYDRAULIC CYLINDER 6"
41	NC17-02-0329	2	HYDRAULIC HOSE (87" LG)

84-57-1330

#	PART #	Qty	TITLE
42	80-42-0305	1	CHUTE GUIDE (UNDER)
43	80-42-0310	1	CHUTE GUIDE (UNDER)
44	80-42-0315	1	CHUTE GUIDE (TOP)
45	80-42-0320	1	CHUTE GUIDE (TOP)
46	NC17-46-0027	4	CHUTE GUIDE (UNDER)
47	NC17-46-0028	4	CHUTE GUIDE (TOP)

#	PART #	Qty	TITLE
1	48-01-7527	1	HYDRAULIC HOSE SUPPORT
2	48-50-1025	1	HYDRAULIC ENGINE SPROCKET
3	80-13-0100	2	HYDRAULIC RESTRICTOR
4	80-45-0000	2	HEX. REDUCER 1/4 NPT X 1/2 NPT
5	81-01-7600	1	HYDRAULIC HOSE SUPPORT
6	NC01-07-0111	1	CARR. BOLT GR5 ZINC 3/8-16 X 1 1/2"
7	NC01-17-0114	2	HEX. BOLT GR2 ZINC 3/8-16 X 1"
8	NC01-33-0113	4	HEX.BOLT GR8 ZINC 3/8-16 X 3/4"
9	NC01-45-0184	1	HEX. BOLT GR8.8 ZINC 8MM X 20MM
10	NC01-96-0011	1	NYLON NUT 3/8-16
11	NC02-07-0018	2	HEX. NUT ZINC 3/8-16
12	NC02-26-0504	1	WASHER
13	NC02-26-1525	2	WASHER INOX .406" D.I. X .815" D.E.
14	NC02-32-0011	1	LOCK WASHER ZINC 5/16"
15	NC02-32-0012	6	LOCK WASHER ZINC 3/8"
16	NC02-44-0103	2	SET SCREW 5/16-18 X 3/8"
17	NC13-45-0367	2	45°-7/8-14 MALE O RING X 1/2 FEM.TOUR.NPT PT
18	NC13-45-0369	2	QUICK COUPLER 1/2-14 NPTF
19	NC13-45-0378	2	HYDRAULIC RESTRICTOR BUSHING
20	NC14-45-0156	1	HYDRAULIC MOTOR
21	NC17-02-0328	2	HYDRAULIC HOSE (63" LG)
22	NC17-46-0031	1	HYDRAULIC MOTOR BUSHING

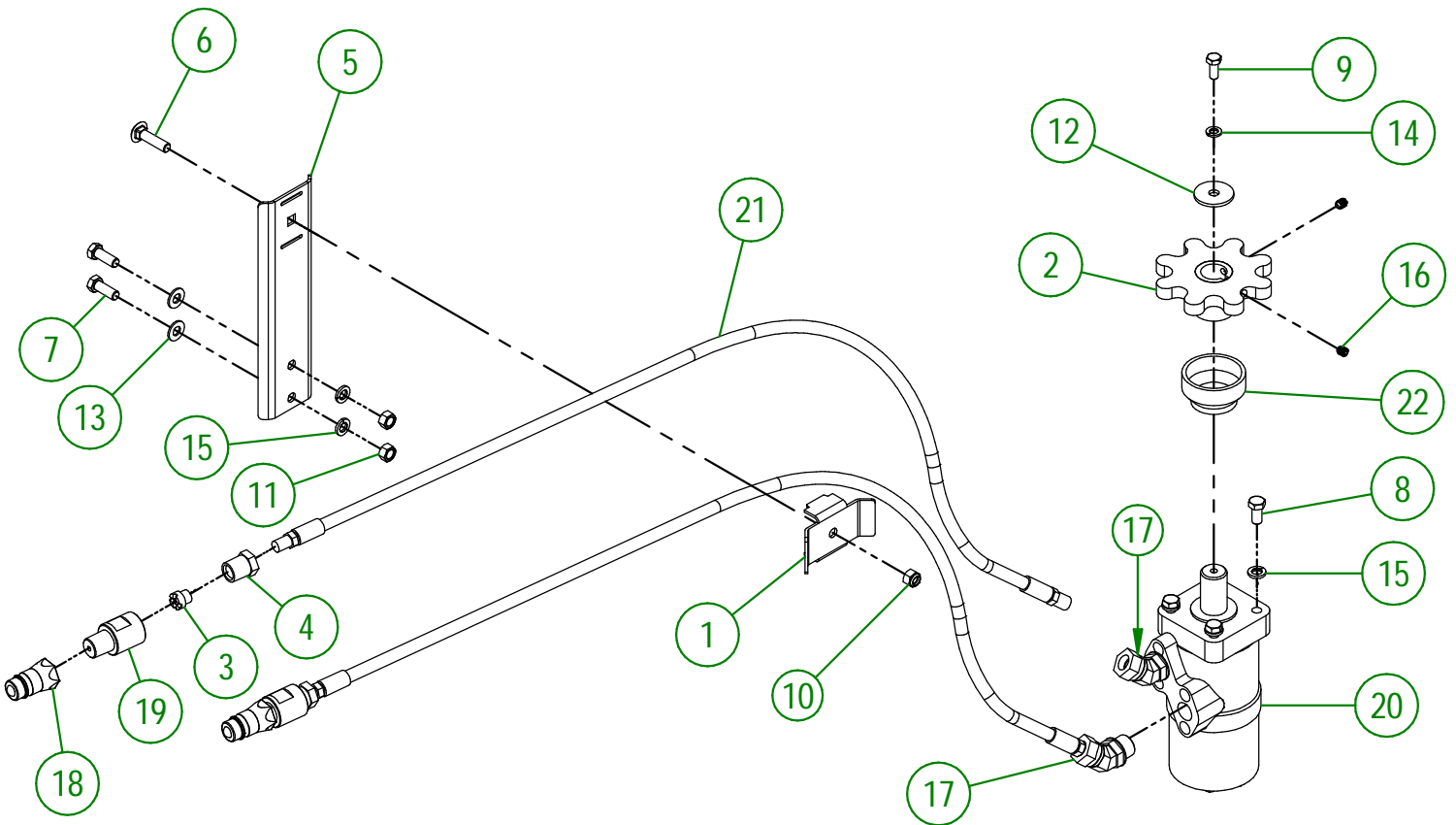

AGRIMETAL
HYDRAULIC MOTOR GROUP

CREATION : 2022-01-26
REVISION : 2026-03-25

ASSEMBLY : **80-57-0410**
AUTHOR : J. HOULE

#	PART #	Qty	TITLE
1	80-55-0010	1	GEARBOX
2	NC02-25-0011	14	WASHER SAE ZINC 17/32 ID
3	80-21-0010	4	TRANSMISSION BUSHING
4	NC02-32-0014	12	LOCK WASHER ZINC 1/2"
5	NC01-33-0248	4	HEX. BOLT .GR8 NC ZINC 1/2-13 X 1 1/4"
6	NC01-33-0251	4	HEX. BOLT GR8 NC ZINC 1/2-13 X 2"
7	80-41-0135	1	PTO GUARD STEEL CABLE
8	NC01-64-0005	2	OVAL SLEEVE (ALUMINUM)
9	80-41-0900	1	IMPELLER KEY
10	80-57-0040	1	PTO GUARD
11	NC13-50-0110	1	IMPORTANT/NOTICE PTO POSTER
12	NC13-25-0019	1	BLACK TIE RAP
13	80-34-0030	1	PTO SHAFT T60
14	NC01-63-0027	1	HAIRPIN COTTER
15	80-01-7526	1	PTO GUARD SUPPORT
16	80-04-0480	1	GEARBOX BRACE
17	80-04-0485	1	GEARBOX BRACE
18	NC01-33-0249	4	CAP SCREW GR8 NC ZINC 1/2-13 X 1 1/2" LG
19	NC02-07-0020	4	HEX. NUT ZINC 1/2-13

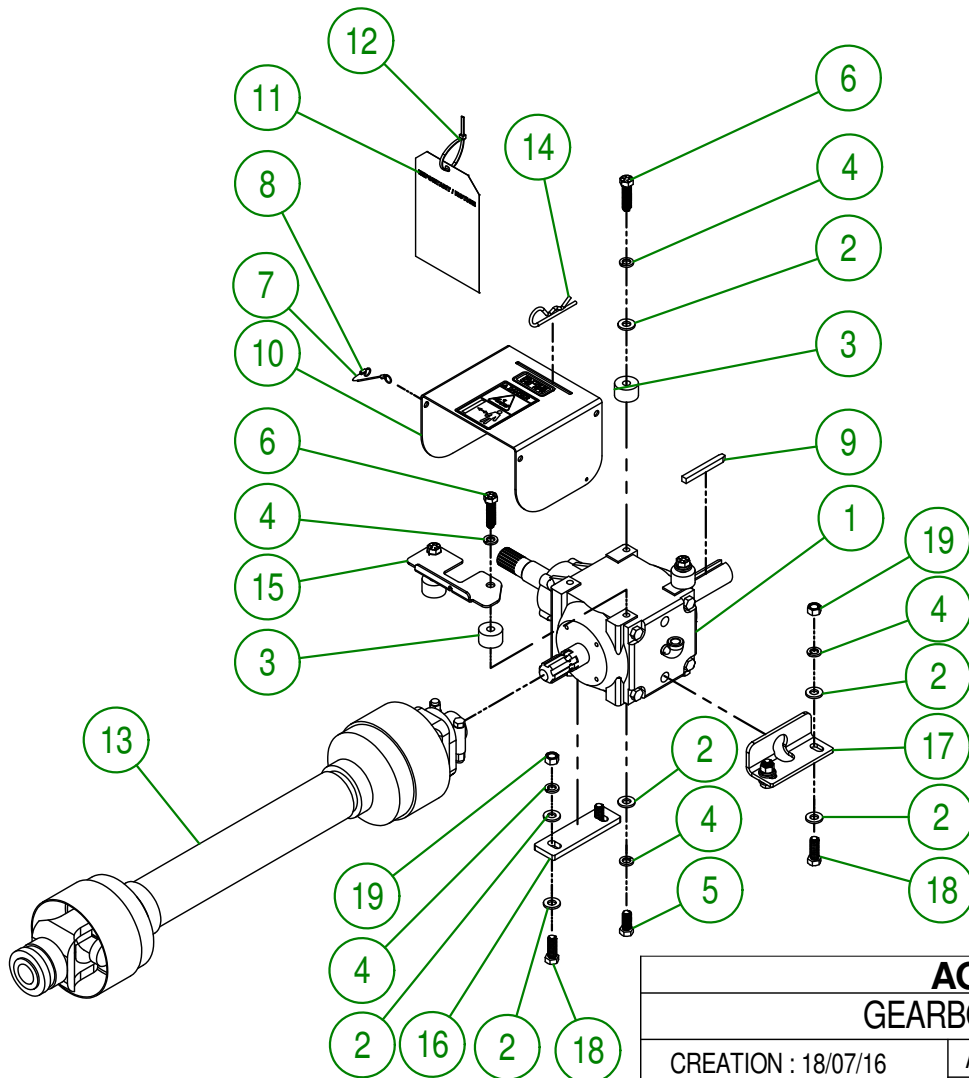

AGRIMETAL
GEARBOX GROUPING

CREATION : 18/07/16
 REVISION : 11/04/19

ASSEMBLY : **80-57-0430**
 AUTHOR : Dessin2 | Page 10 de 20

#	PART #	Qty	TITLE
1	80-50-0050	1	IMPELLER
2	NC01-94-0011	2	LOCK NUT 3/8-24
3	NC01-37-0121	2	HEX. BOLT GR8 ZINC 3/8-24 X 2 3/4" LG
4	NC02-32-0016	1	LOCK WASHER ZINC 5/8"
5	NC01-25-0395	1	HEX. BOLT GR5 ZINC 5/8-11 X 1 3/4" LG
6	80-04-0185	1	WASHER

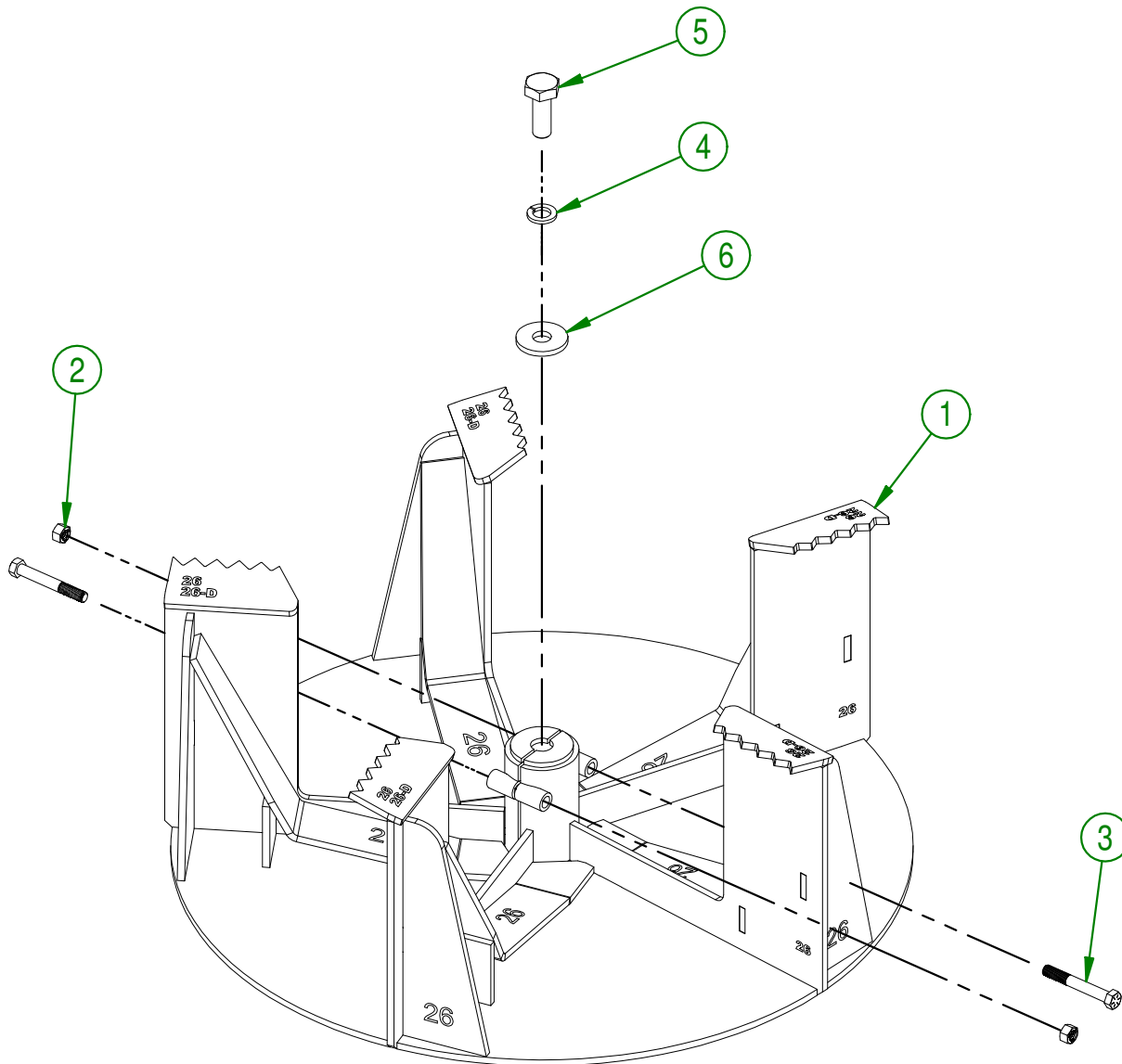

AGRIMETAL	
IMPELLER GROUP	
CREATION : 13/04/18	ASSEMBLY : 80-57-0426
REVISION : 25/06/20	AUTHOR : F.HÉLIE Page 11 de 20

#	PART #	Qty	TITLE
1	NC01-25-0247	6	HEX. BOLT GR5 ZINC 1/2-13 X 1" LG
2	NC02-32-0014	6	LOCK WASHER ZINC 1/2"
3	80-50-0111	1	LEFT SNOW GUARD
4	80-50-0113	1	RIGHT SNOW GUARD

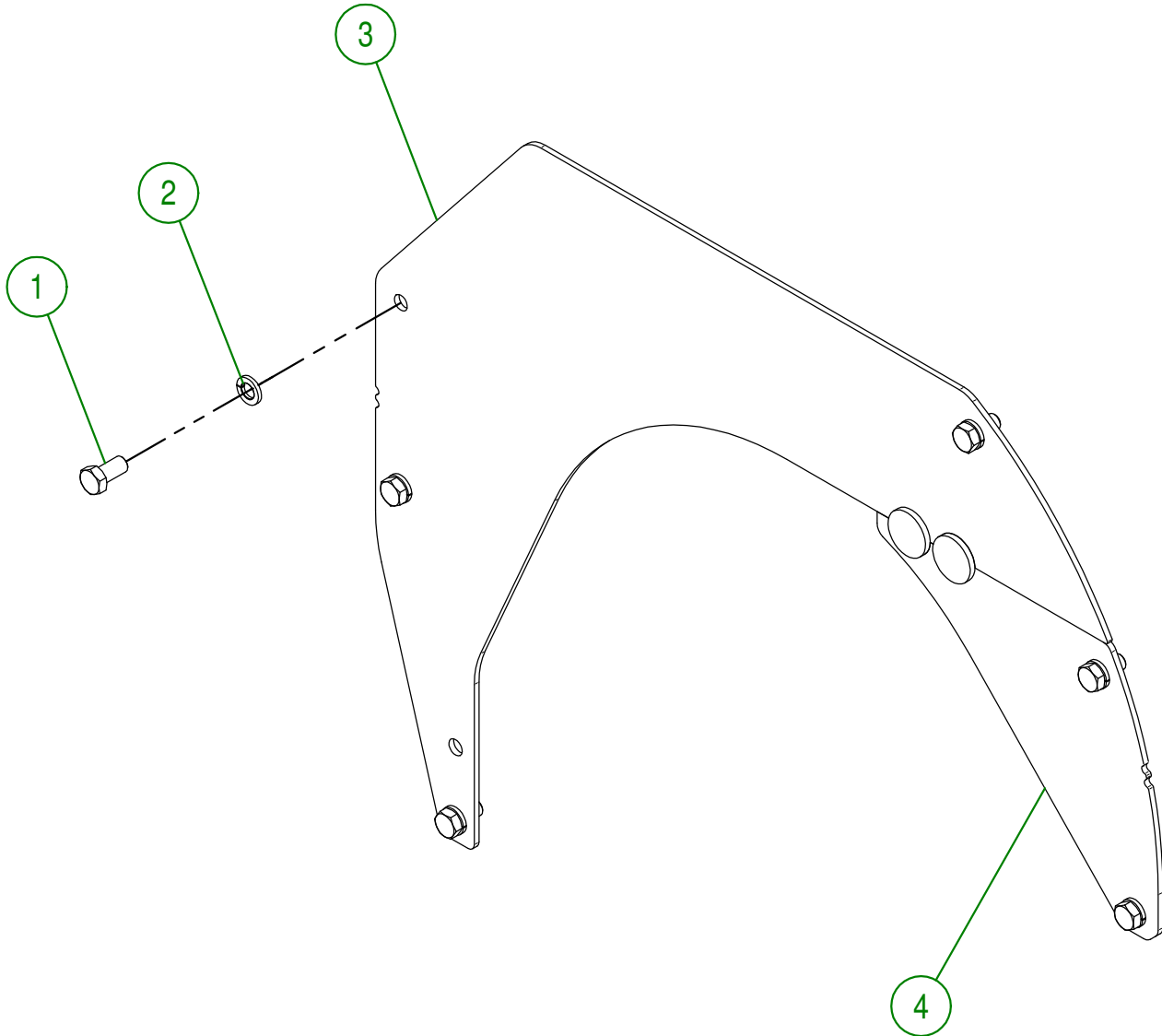

AGRIMETAL	
SNOW GUARD GROUP	
CREATION : 18/07/16	ASSEMBLY : 80-57-0420
REVISION : 03/04/18	AUTHOR : J. HOULE Page 12 de 20

80-57-1415

#	PART #	Qty	TITLE
1	NC14-75-0160	2	FLANGE BEARING UCF207-20 1 1/4" ID
2	80-50-1080	1	SPIRAL
3	NC02-25-0011	8	WASHER SAE ZINC 17/32 ID
4	NC01-17-0250	8	HEX. BOLT GR2 ZINC 1/2-13 X 1 3/4"
5	NC02-32-0014	8	LOCK WASHER ZINC 1/2"
6	NC02-07-0020	8	HEX. NUT ZINC 1/2-13
8	NC14-55-0294	1	60A32H SPROCKET
9	NC01-37-0115	4	HEX. BOLT GR8 ZINC 3/8-24 X 1 1/4" LG
10	NC01-94-0011	4	LOCK NUT 3/8-24
11	80-51-0140	1	SHAFT OF THE SPIRAL
12	80-510-0091	1	SHAFT OF THE SPIRAL (SPROCKET)

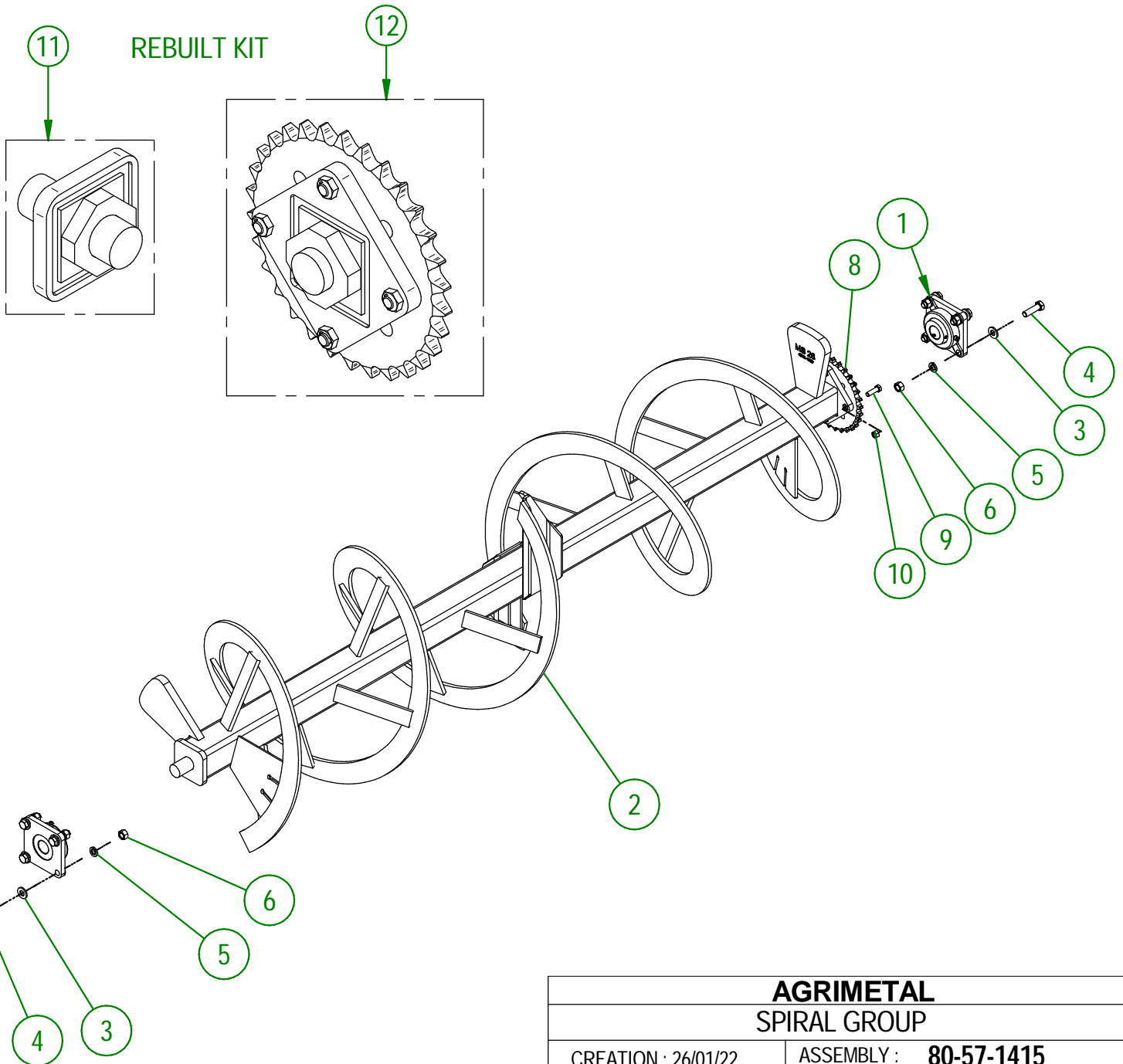

AGRIMETAL	
SPIRAL GROUP	
CREATION : 26/01/22	ASSEMBLY : 80-57-1415
REVISION : 09/12/25	AUTHOR : J. HOULE

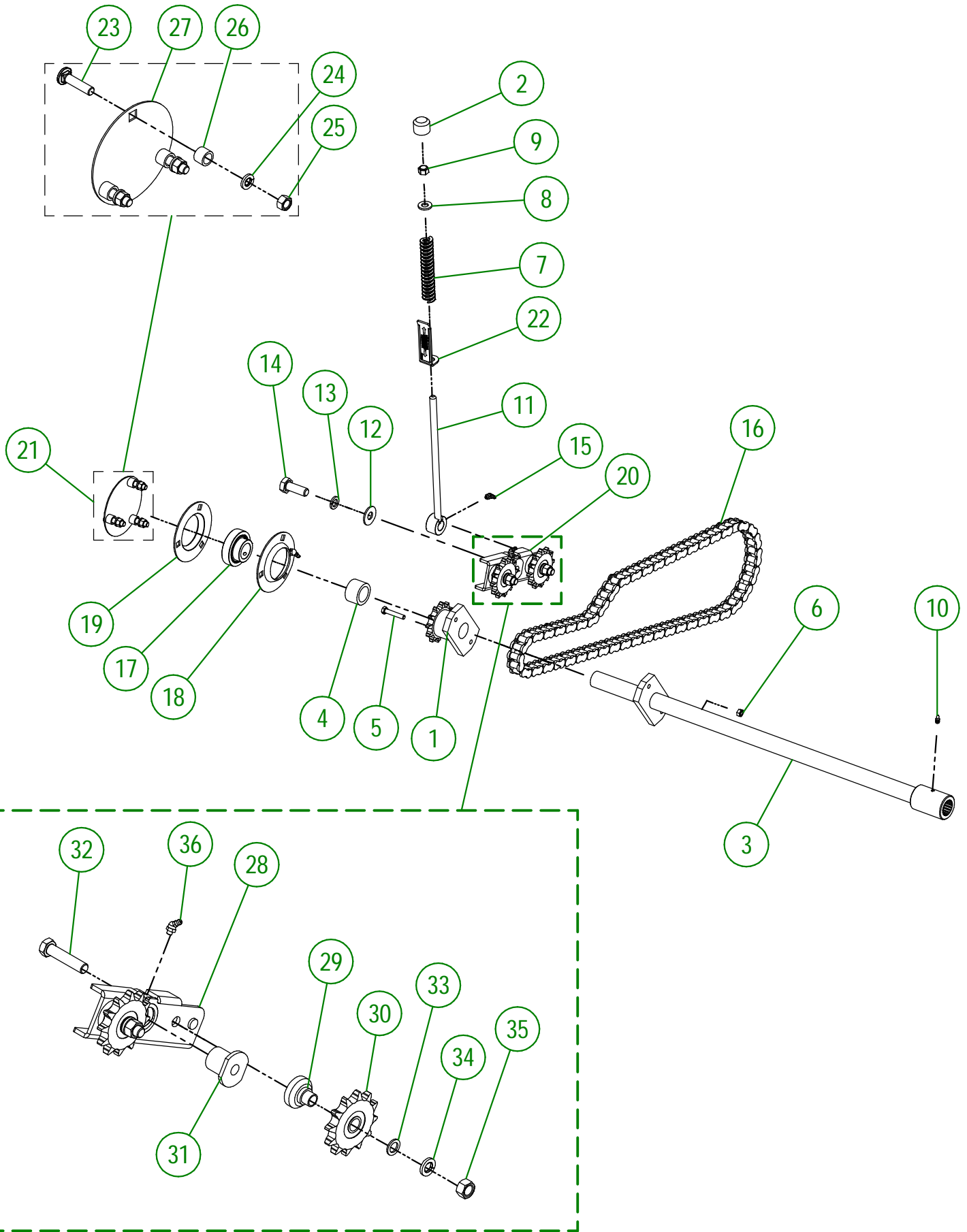

AGRIMETAL	
DRIVE TRAIN SPIRAL GROUP	
CREATION : 26/01/22	ASSEMBLY : 80-57-1435
REVISION : 13/04/23	AUTHOR : Dessin2

80-57-1435

#	PART #	Qty	TITLE
1	NC14-55-0293	1	60B12H SPROCKET
2	80-42-0110	1	THREADED ROD CAP
3	80-50-1065	1	DRIVE TRAIN SPIRAL
4	80-21-0025	1	SPIRAL DRIVE TRAIN BUSHING
5	NC01-17-0063	1	CAP SCREW GR2 NC ZINC 5/16-18 X 1 3/4"
6	NC01-93-0010	1	LOCK NUT ZINC 5/16-18
7	NC13-86-0053	1	BLUE SPRING 1/2" ID X 1" OD X 6" LG
8	NC02-25-0011	1	WASHER SAE ZINC 17/32 ID
9	NC01-96-0014	1	NYLON-INSERT LOCKNUT ZINC 1/2-13
10	NC01-69-0785	1	STRAIGHT GREASE FITTING 1/4-28
11	80-50-0040	1	THREADED ROD
12	NC02-22-0013	1	WASHER ZINC 5/8 ID X 1 1/2 OD
13	NC02-32-0016	1	LOCK WASHER ZINC 5/8"
14	NC01-17-0395	1	HEX. BOLT GR2 ZINC 5/8-11 X 1 3/4"
15	NC01-69-0787	1	GREASE FITTING STRAIGHT 1/4-28 X 90
16	80-37-1005	1	#60 HD CHAIN
17	NC14-75-0164	1	SB207-20 BEARING
18	80-55-0030	1	PRESSED STEEL FLANGE WITH GREASE FITTING
19	NC14-75-0093	1	PRESSED STEEL FLANGE
20	80-55-0025	1	CHAIN TENSIONER GROUP
21	82-57-2950	1	BEARING GUARD GROUP.
22	80-57-0160	1	ADJUSTEMENT INDICATOR

82-57-2950

#	PART #	Qty	TITLE
23	NC01-04-0111	3	CARR. BOLT GR2 ZINC 3/8-16 X 1 1/2"
24	NC02-32-0012	3	LOCK WASHER ZINC 3/8"
25	NC02-07-0018	3	HEX. NUT ZINC 3/8-16
26	82-21-0000	3	BEARING BUSHING GUARD
27	82-01-7540	1	BEARING GUARD

80-55-0025

#	PART #	Qty	TITLE
28	80-50-0045	1	CHAIN TENSIONER
29	80-21-0020	2	CHAIN TENSIONER BUSHING (SPROCKET)
30	NC14-55-0295	2	SPROCKET 60A12H
31	80-13-2400	1	CHAIN TENSIONER BUSHING
32	NC01-29-0252	2	HEX. BOLT GR2 ZINC 1/2-20 X 2 1/4" LG
33	NC02-26-1100	2	WASHER SAE ZINC 17/32 ID X 13/16" OD
34	NC02-32-0014	2	LOCK WASHER ZINC 1/2"
35	NC02-10-0020	2	HEX. NUT ZINC 1/2-20
36	NC01-69-0786	1	GREASE FITTING 1/4-28 X 45

#	PART #	Qty	TITLE
1	NC01-04-0107	4	CARR. BOLT GR2 ZINC 3/8-16 X 3/4"
2	NC02-14-0019	4	FLANGE NUT HEX. NC 3/8-16 GR. B
3	80-50-0070	1	CHAIN GUARD

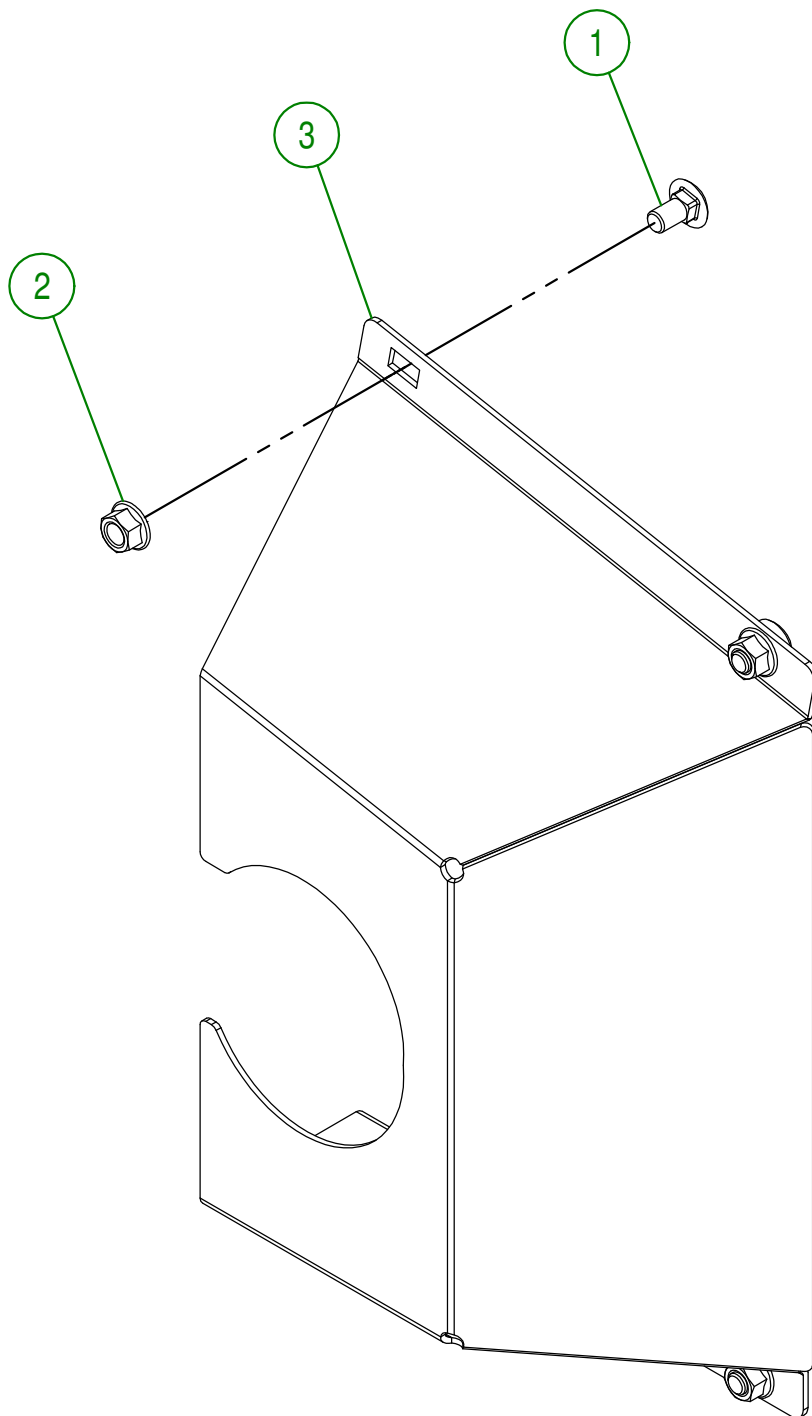
**AGRIMETAL****SPIRAL CHAIN GUARD GROUP**CREATION : 18/07/16
REVISION : 03/04/18ASSEMBLY : **80-57-0405**
AUTHOR : J. HOULE | Page 16 de 20

#	PART #	Qty	TITLE
1	NC02-26-1525	4	WASHER INOX .406" D.I. X .815" D.E.
2	NC01-17-0114	2	HEX. BOLT GR2 ZINC 3/8-16 X 1"
3	NC01-96-0011	2	NYLON NUT 3/8-16
4	80-57-0036	1	CHAIN GUARD

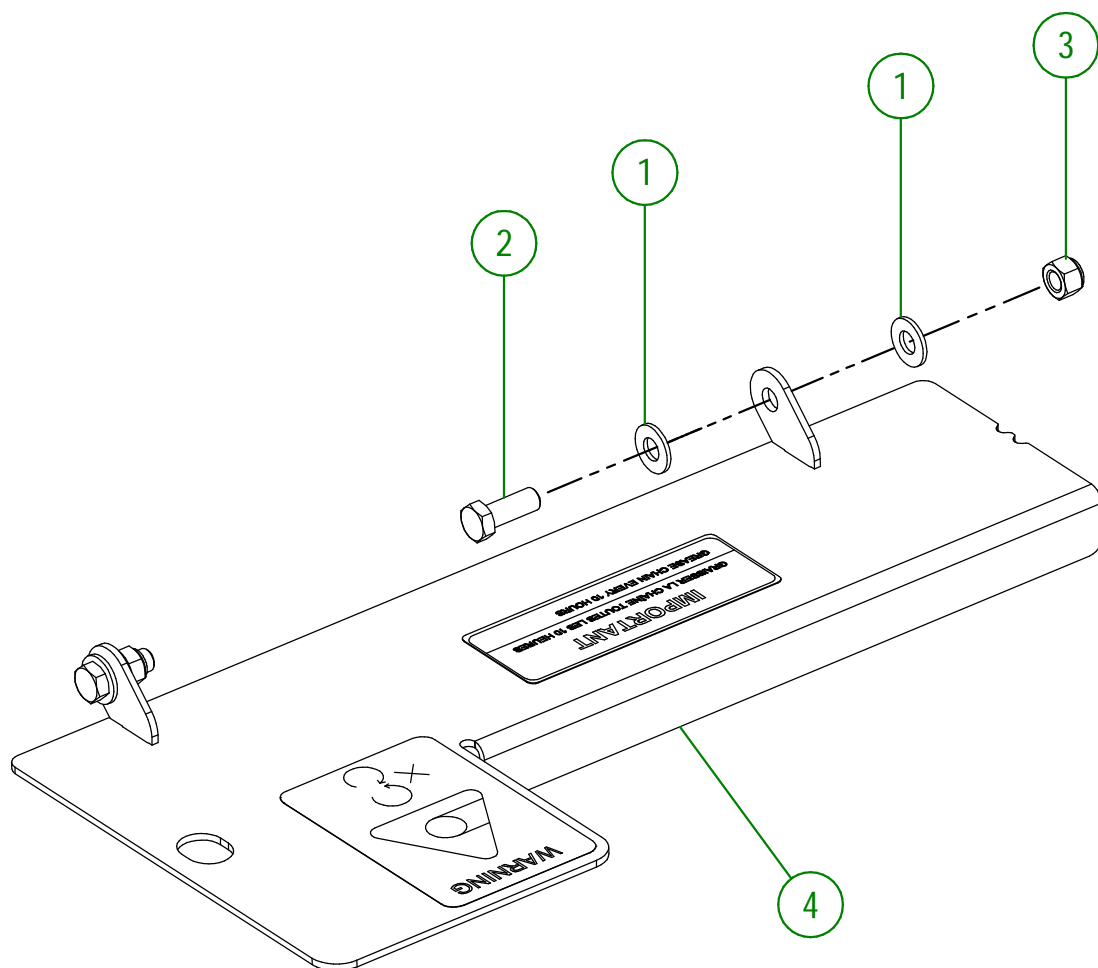

AGRIMETAL	
CHAIN GUARD GROUP	
CREATION : 26/01/22	ASSEMBLY : 80-57-0445
REVISION : 19/12/25	AUTHOR : J. HOULE

#	PART #	Qty	TITLE
1	NCI3-30-0237	1	PLASTIC TUBE FOR OPERATOR'S MANUAL
2	NC02-22-0008	2	WASHER ZINC 5/16"
3	NC01-17-0007	2	HEX. BOLT GR2 ZINC 1/4-20 X 1 1/4"
4	NC01-96-0009	2	NYLON-INSERT LOCKNUT ZINC 1/4-20
5	80-57-0030	1	SET OF 6 SHEAR BOLT WITH NUT
6	80-98-0522	1	ENGLISH OPERATOR'S MANUAL (MS26, 26-D, 24-D)

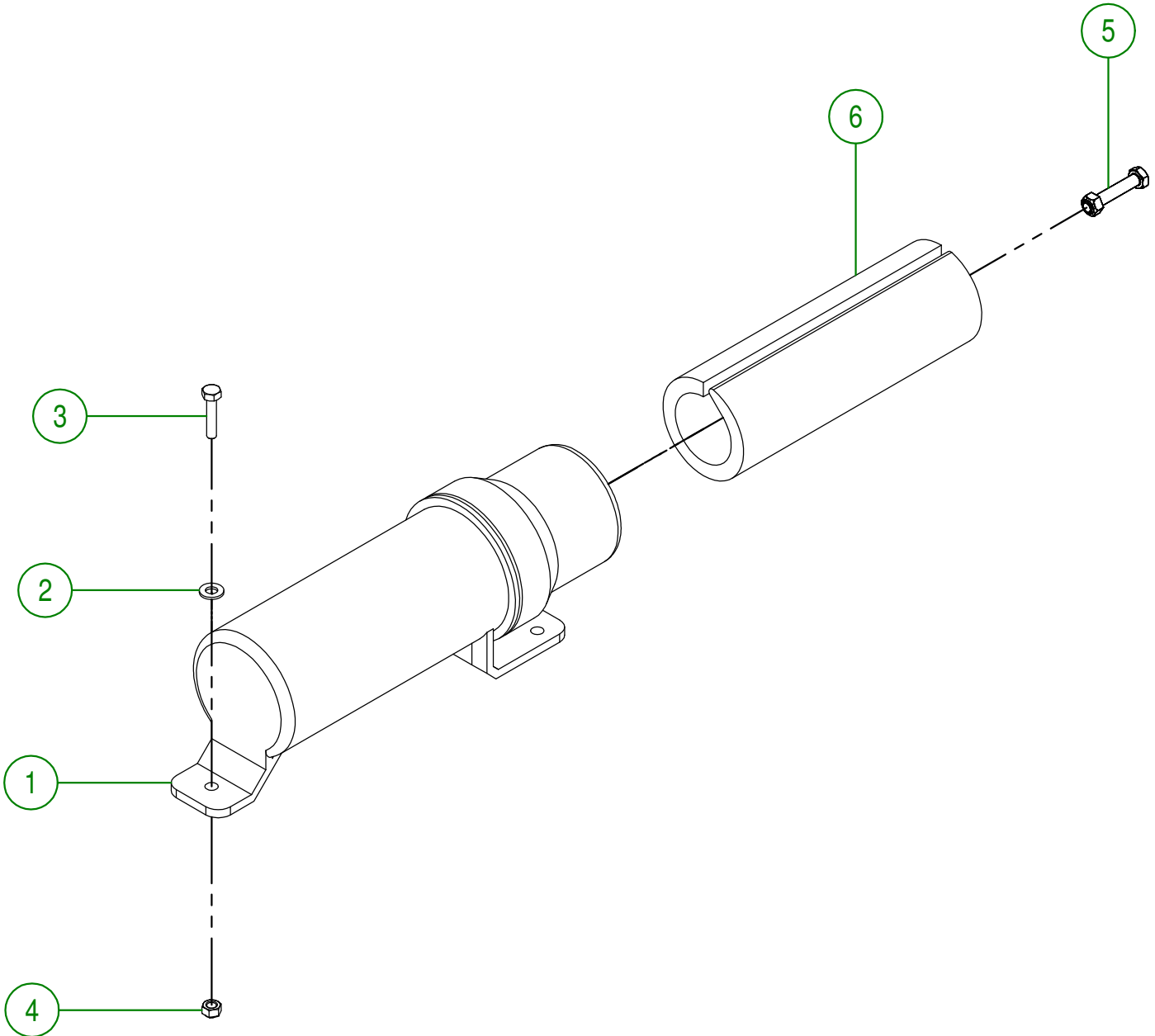

AGRIMETAL	
OPERATOR'S MANUAL TUBE GROUP	
CREATION : 18/07/16	ASSEMBLY : 80-57-0400
REVISION : 08/05/18	AUTHOR : J. HOULE Page 18 de 20

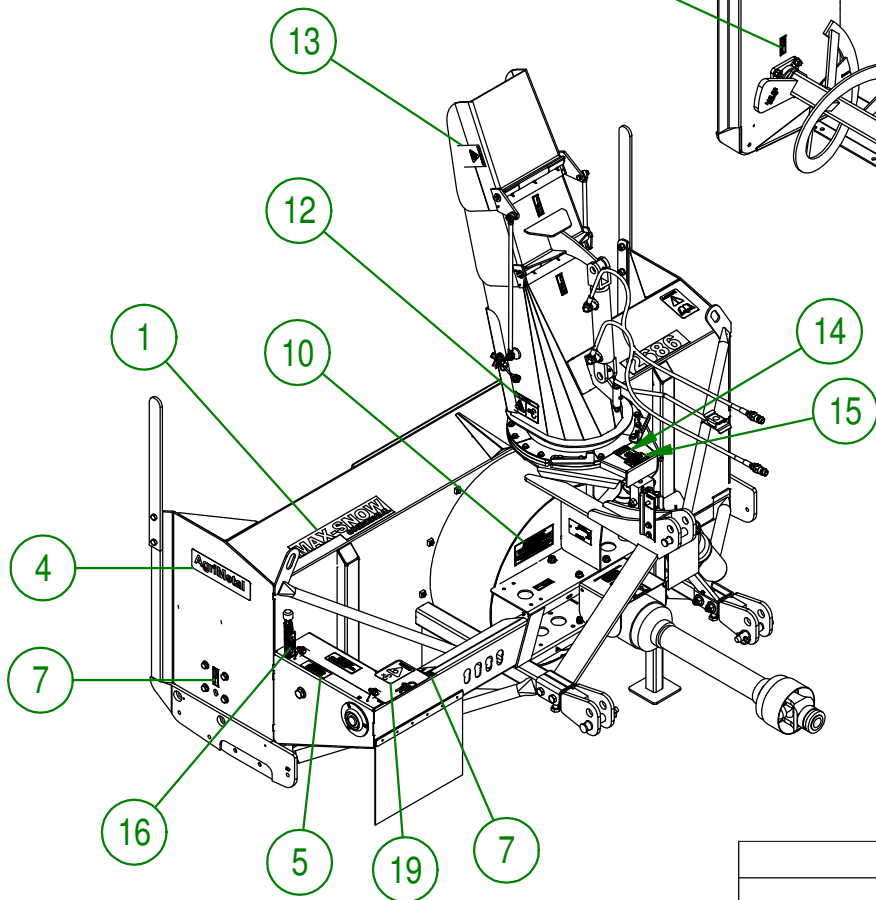
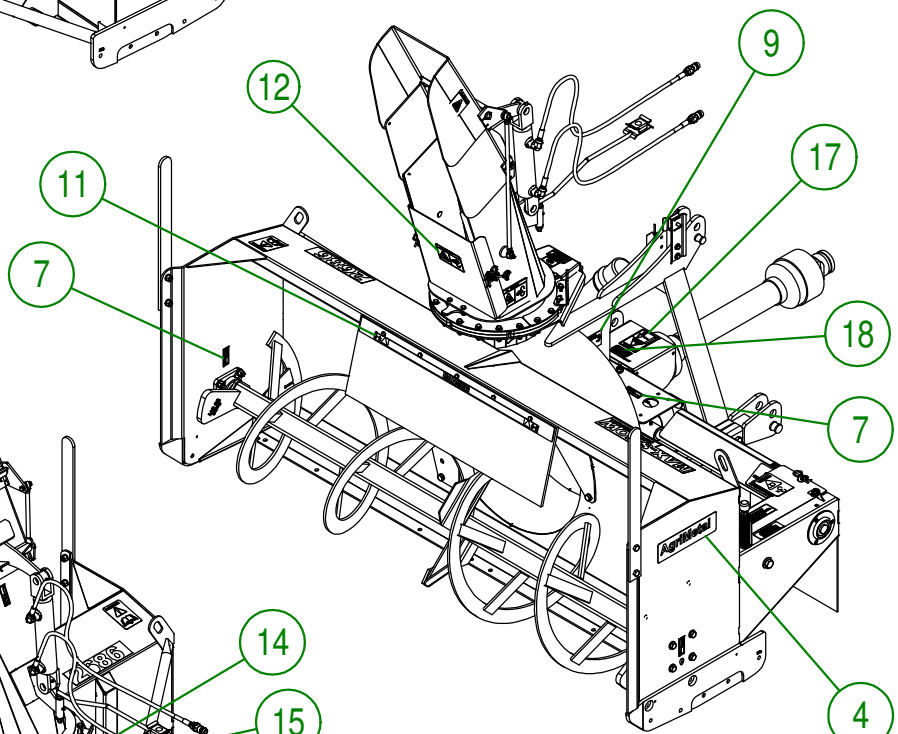
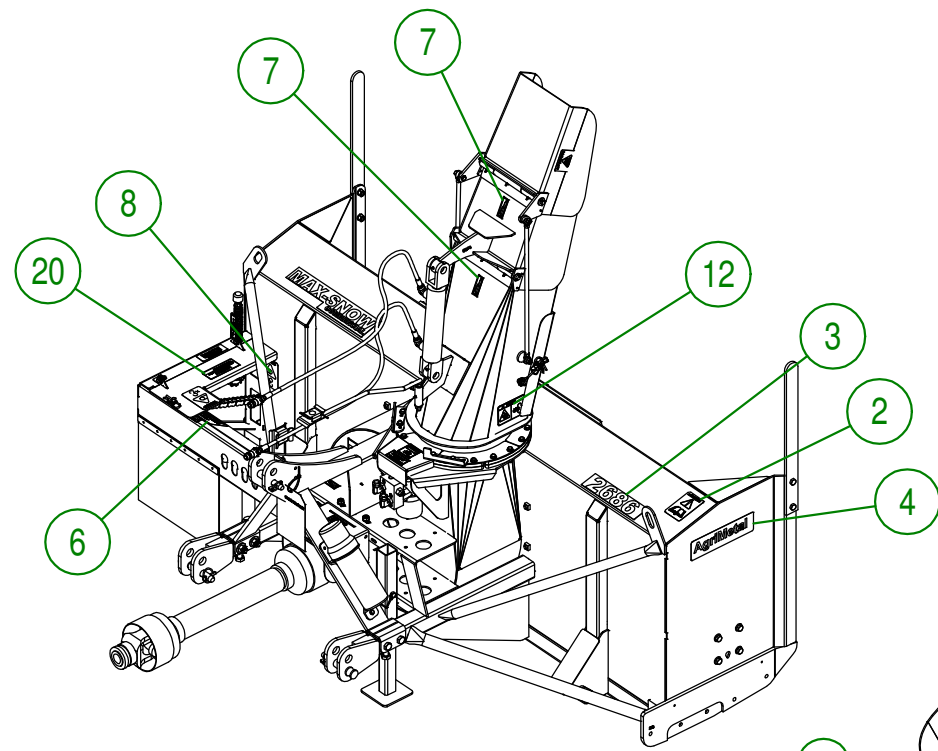

AGRIMETAL

MS 2686

CREATION : 18/07/16
 REVISION : 18/11/19

ASSEMBLY : **80-99-1000**

AUTHOR : J. HOULE Page 19 de 20

#	PART #	Qty	TITLE
1	NC13-33-0241	1	STICKER MAX-SNOW COMMERCIAL
2	NC13-33-0183	1	STICKER CAUTION OPERATION MANUAL
3	NC13-33-0244	1	STICKER 2682
4	NC13-33-0035	2	STICKER AGRIMETAL
5	NC13-33-0104	1	STICKER IMPORTANT 4 INCHES 100 MM
6	NC13-33-0280	1	STICKER SHEAR BOLT
7	NC13-33-0024	6	STICKER GREASE HERE
8	NC13-33-0189	1	STICKER DANGER (PERSON AND CHAIN DRIVE)
9	NC13-50-0086	1	SERIAL NUMBER PLATE
10	NC13-33-0317	1	STICKER GREASE DRIVE LINE TELESCOPIC SHAFT
11	NC13-33-0274	1	STICKER DANGER
12	NC13-33-0249	3	STICKER DANGER
13	NC13-33-0192	2	STICKER (PROJECTION RISK)
14	NC13-33-0326	1	STICKER DANGER (HAND)
15	NC13-33-0327	1	STICKER END ROTATION ADJUSTMENT
16	NC13-33-0344	1	ADJUSTEMENT INDICATOR STICKER
17	NC13-33-0187	1	STICKER DANGER (PTO AND PERSON)
18	NC13-33-0005	1	STICKER MAXIMUM 540 RPM
19	NC13-33-0283	1	STICKER DANGER (PERSON AND CHAIN DRIVE)
20	NC13-33-0343	1	GREASE CHAIN EVERY 10 HOURS STICKER

AGRIMETAL**MS 2686**

CREATION : 18/07/16
 REVISION : 18/11/19

ASSEMBLY : **80-99-1000**
 AUTHOR : J. HOULE Page 20 de 20