

# AgriMetal

## PARTS LIST

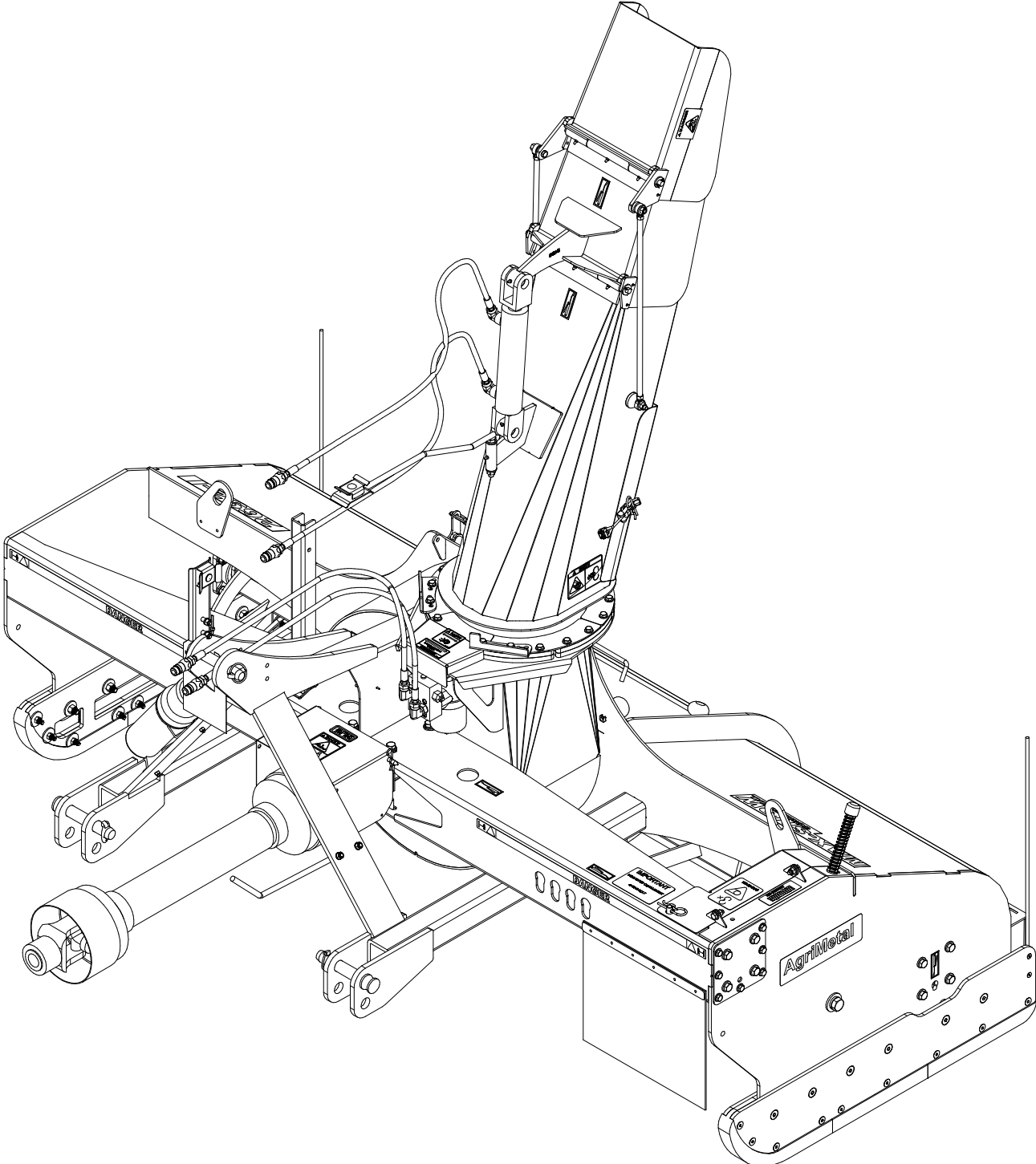

**MS 2692-i**

#	PART #	Qty	TITLE
1	NC13-15-0317	1	CENTER KNIFE (RUBBER)
2	84-42-0036	1	LEFT KNIFE (RUBBER)
3	84-42-0035	1	RIGHT KNIFE (RUBBER)
4	91-20-0150	19	WASHER
5	NC01-54-1252	19	HEX BOLT. GR2 STAINLESS 1/2-13 X 2 1/4"
6	NC01-96-0014	19	NYLON INSERT LOCKNUT 1/2-13"
7	84-04-0070	1	KNIFE BRACE
8	84-04-0072	1	RIGHT KNIFE BRACE

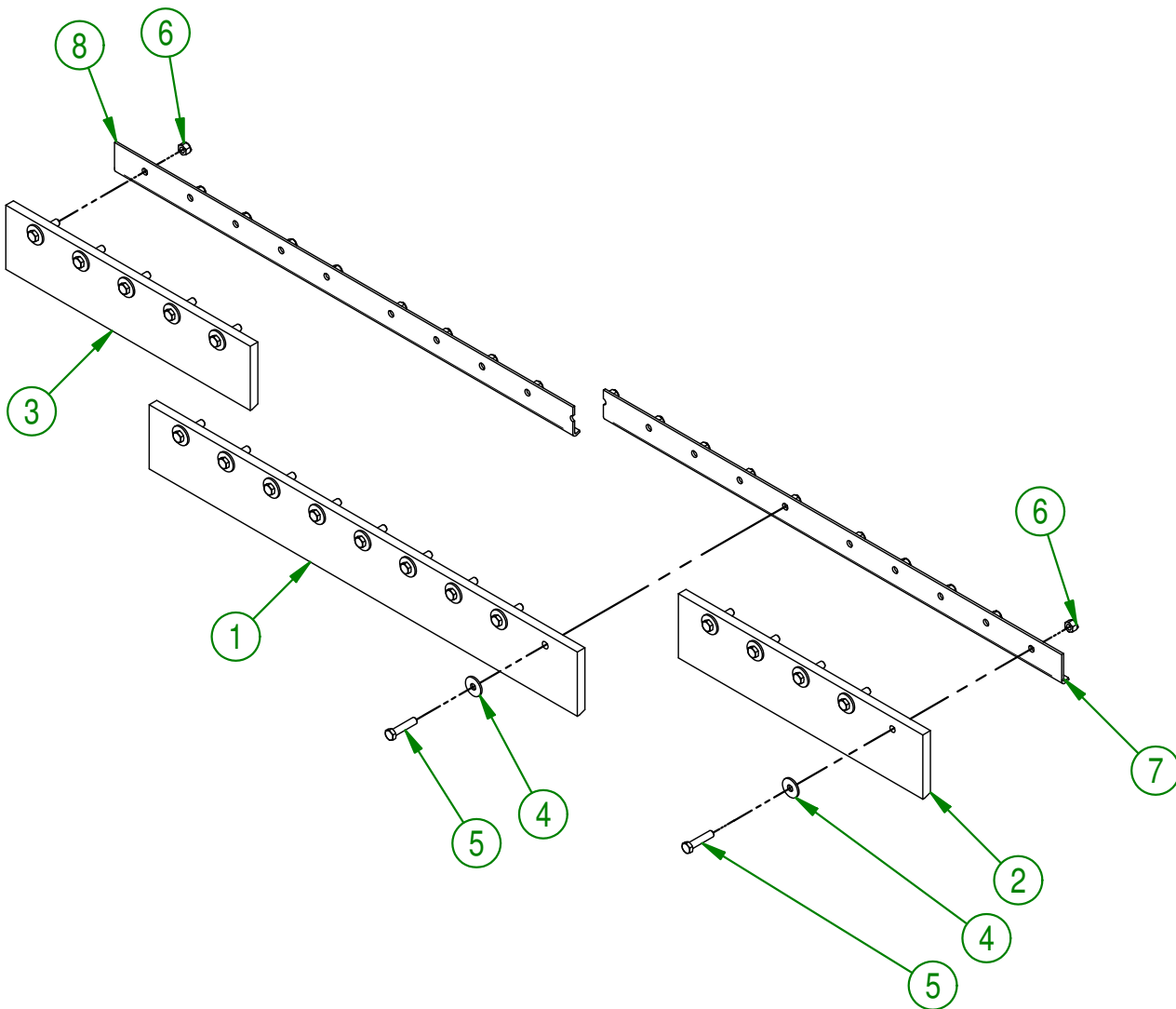

<b>AGRIMETAL</b>	
<b>BLADES KIT (RUBBER) ( 90°)</b>	
CREATION : 06/12/17	ASSEMBLY : <b>84-57-0105</b>
REVISION : 05/03/19	AUTHOR : F.HÉLIE   Page 1 de 17

#	PART #	Qty	TITLE
1	84-04-0925	2	KNIFE SUPPORT BRACE (CONVERSION)
2	84-20-0115	1	KNIFE BRACE
3	NC01-09-0032	12	PLOW BOLT GR5 1/2-13 X 2" LG
4	NC01-93-0014	31	LOCK NUT ZINC 1/2-13
5	NC01-25-0250	19	HEX.BOLT GR5 NC ZINC 1/2-13 X 1 3/4"
6	84-50-9100	1	KNIFE SUPPORT (CONVERSION)
7	84-42-0090	1	RIGHT KNIFE (RUBBER) MS26-i
8	84-42-0095	1	LEFT KNIFE (RUBBER) MS26-i
9	84-04-0547	1	RUBBER KNIFE BRACE
10	NC02-48-0109	13	FLAT SOCKET CAP SCREWS 1/2-20 X 1 1/4" GRADE 8

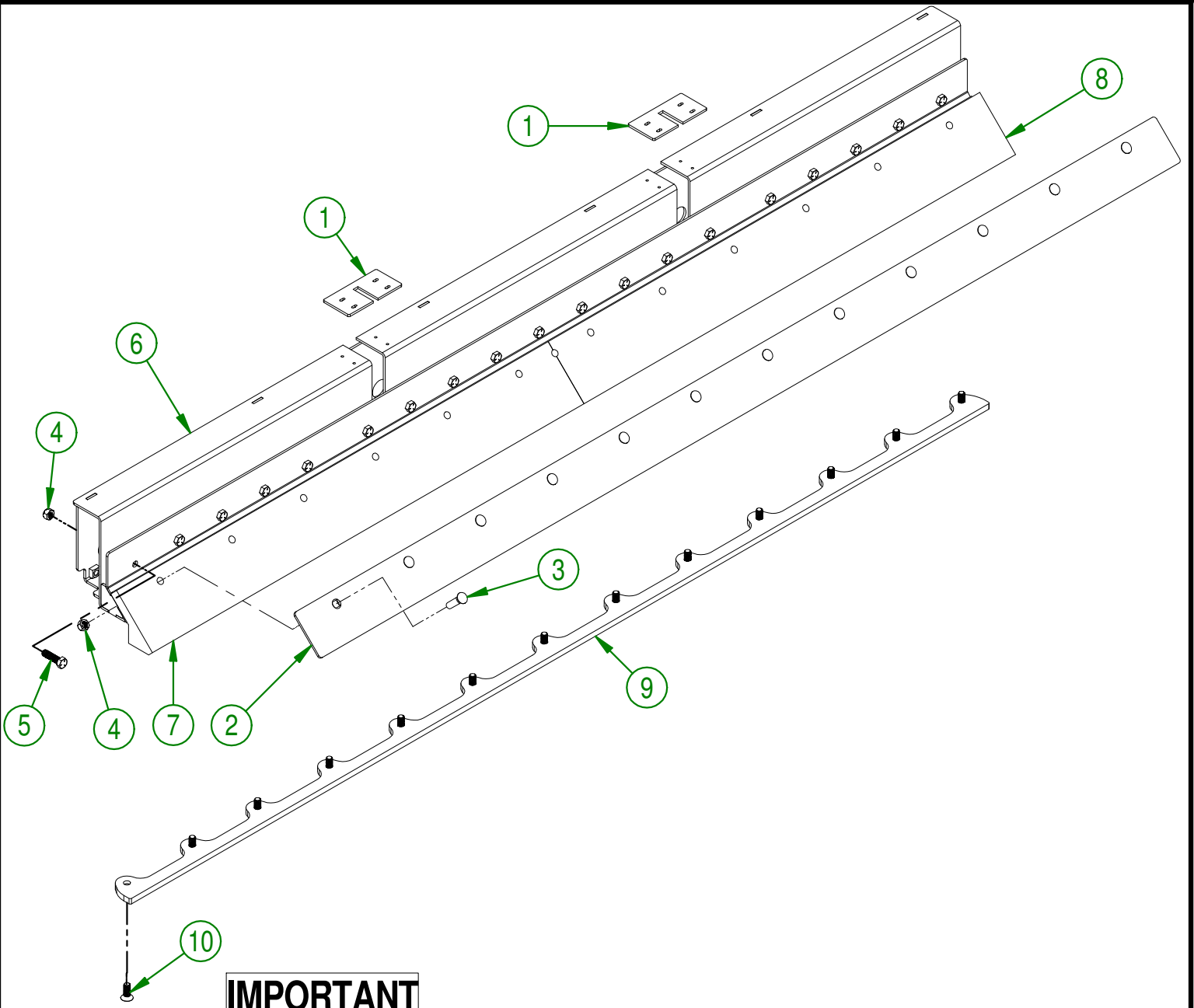

**IMPORTANT**

USE THIS PARTS ONLY IF YOUR SERIAL NUMBER IS INVOLVED:

#37382 AND LESS

**AGRIMETAL**  
CONVERSION KIT (45° KNIFE)

CREATION : 31/10/18  
REVISION : 26/09/19

ASSEMBLY : **84-57-9100**  
AUTHOR : F.HÉLIE

#	PART #	Qty	TITLE
1	84-20-0020	1	FLOATING SKATE (OUTSIDE LEFT)
2	91-42-0150	2	FLOATING SKATE (MIDDLE BACK)
3	91-42-0138	2	FLOATING SKATE (MIDDLE FRONT)
4	84-42-0044	2	FLOATING SKATE (MIDDLE)
5	84-50-0185	1	FLOATING SKATE (INSIDE LEFT)
6	84-20-0023	1	FLOATING SKATE (OUTSIDE RIGHT)
7	84-50-0180	1	FLOATING SKATE (INSIDE RIGHT)
8	NC02-48-0537	18	STAINLESS FLAT HEAD SOCKET CAP SCREW 3/8-16 X 2 1/4"
9	91-20-0163	4	WASHER
10	91-20-0160	14	WASHER
11	NC02-48-0549	12	STAINLESS FLAT HEAD SOCKET CAP SCREW 1/2-13 X 2 1/4"
12	91-20-0150	12	WASHER
13	NC01-96-0014	12	NYLON INSERT LOCKNUT 1/2-13"
14	NC01-96-0011	18	NYLON NUT 3/8-16
15	39-01-2440	2	GUIDE ROD CLAMP
16	39-42-0600	2	GUIDE ROD
17	NC02-48-0513	4	HEX DRIVE FLAT HEAD SCREW 1/4-20 X 1 1/2"
18	NC01-96-0009	4	NYLON-INSERT LOCKNUT ZINC 1/4-20
19	91-09-0000	12	BUSHING
20	NC13-86-0052	6	SPRING 1/2" ID X 1" OD X 5" LG

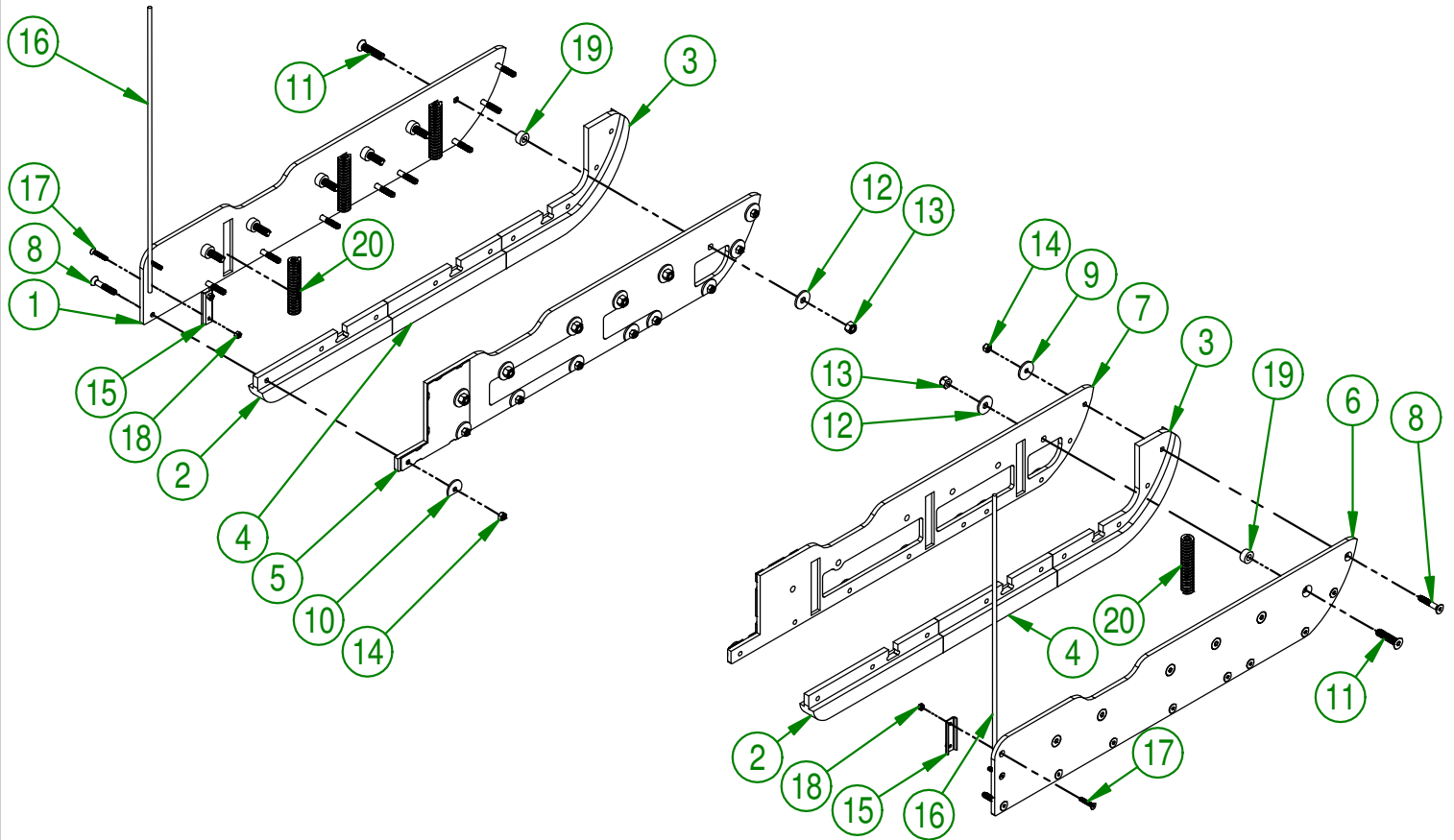

## AGRIMETAL

### FLOATING SKATE GROUP

CREATION : 06/12/17  
REVISION : 25/10/19

ASSEMBLY : **84-57-0150**

AUTHOR : F.HÉLIE

Page 3 de 17

84-57-1315

#	PART #	Qty	TITLE
1	84-50-1310	1	PTO SUPPORT
2	01-01-2485	2	FLAT WASHER
3	NC02-32-0012	2	LOCK WASHER ZINC 3/8"
4	NC02-07-0018	2	HEX. NUT ZINC 3/8-16

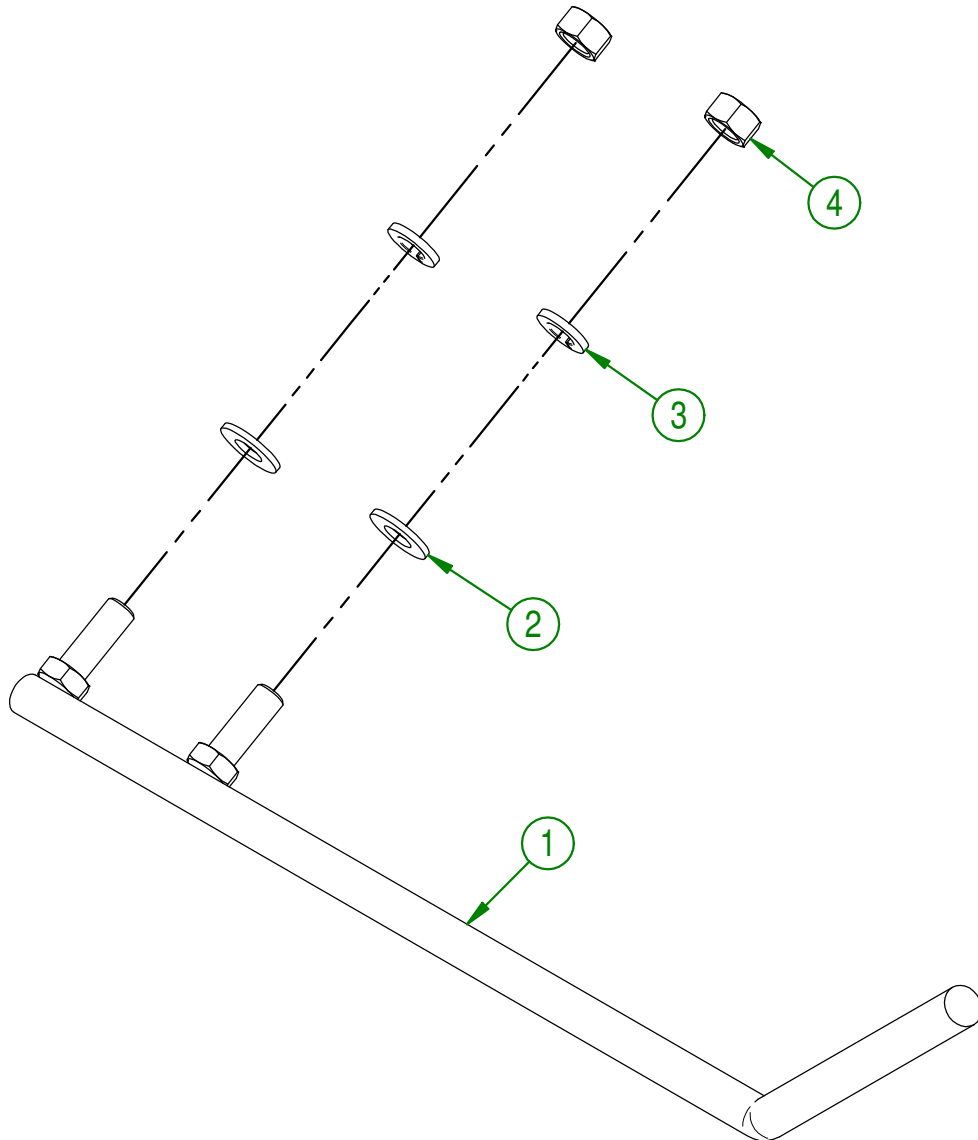

<b>AGRIMETAL</b>	
PTO SUPPORT GROUP (OPTION)	
CREATION : 06/12/17	ASSEMBLY : <b>84-57-1315</b>
REVISION : 03/01/18	AUTHOR : J.KABWE   Page 4 de 17

84-57-0125

#	PART #	Qty	TITLE
1	NC01-63-0026	1	COTTER PIN ZC 5/32" X 3"
2	NC13-15-0300	1	SNOW GUARD
3	80-01-1075	1	SNOW GUARD BRACE
4	NC01-78-0041	6	POP RIVET STAINLESS STEEL ROD STEEL .187" X .690"
5	48-20-0065	2	3 POINT PIN
6	48-20-0060	1	3 POINT PIN
7	NC01-69-1100	3	LINCH PIN 3/8"
8	84-50-0090	1	STAND
9	NC01-69-1306	1	LOCKING PIN 3/8" X 2 1/2" LG
10	84-57-0120	1	FRAME

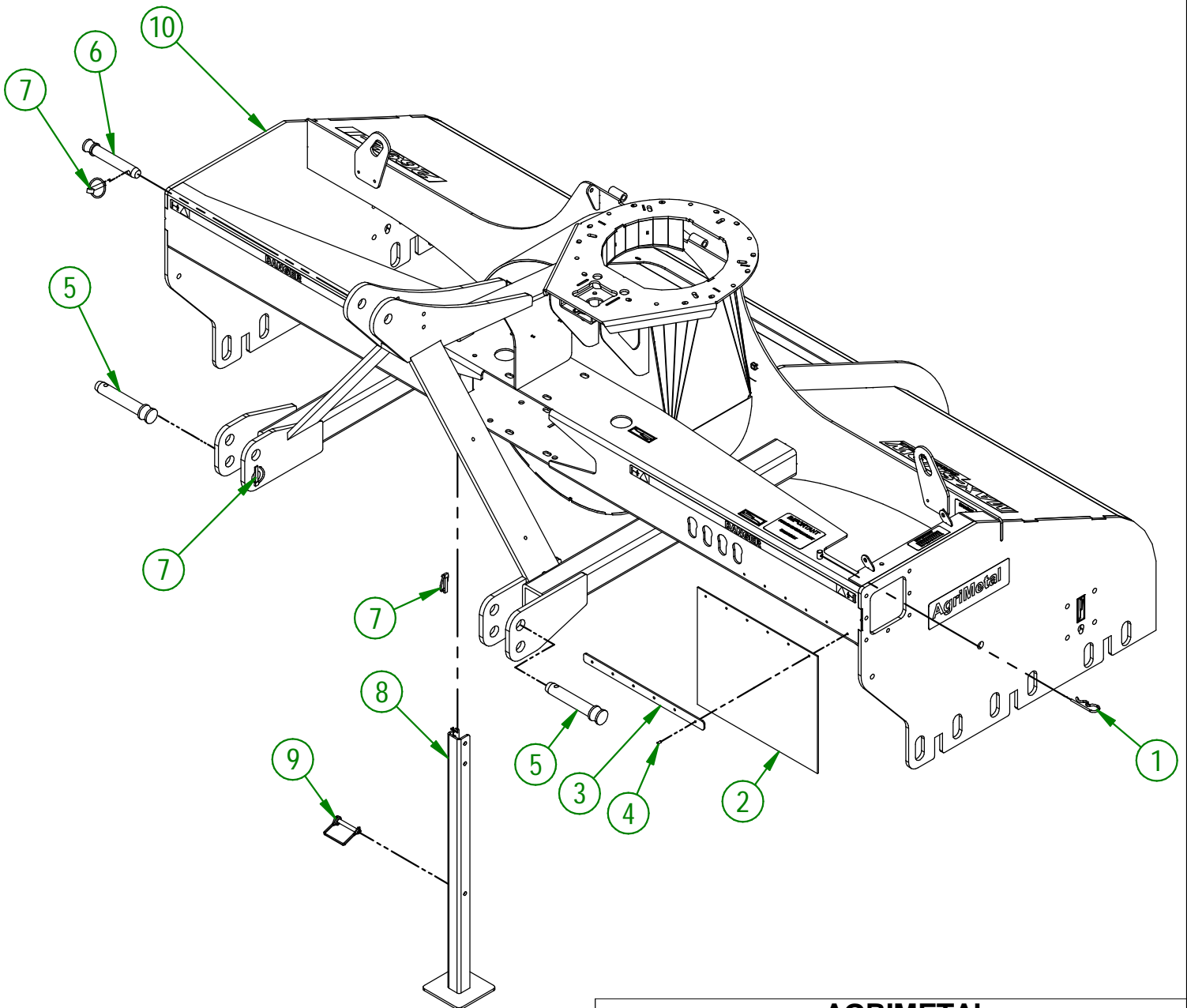

**AGRIMETAL**  
**FRAME GROUP**

CREATION : 07/12/17  
REVISION : 06/01/26

ASSEMBLY : **84-57-0125**  
AUTHOR : F.HÉLIE

84-57-0135

#	PART #	Qty	TITLE
1	NC01-17-0259	2	BOLT HEX. GR2 ZINC 1/2-13 X 4"
2	NC01-96-0014	2	NYLON-INSERT LOCKNUT ZINC 1/2-13
3	NC17-46-0018	4	HANDLE KNOB
4	NC01-17-0119	4	HEX. BOLT GR2 ZINC 3/8-16 X 2 1/4"
5	84-57-0175	1	IMPELLER ACCESS DOOR
6	NC01-69-1100	1	LINCH PIN 3/8"
7	01-01-2485	4	FLAT WASHER

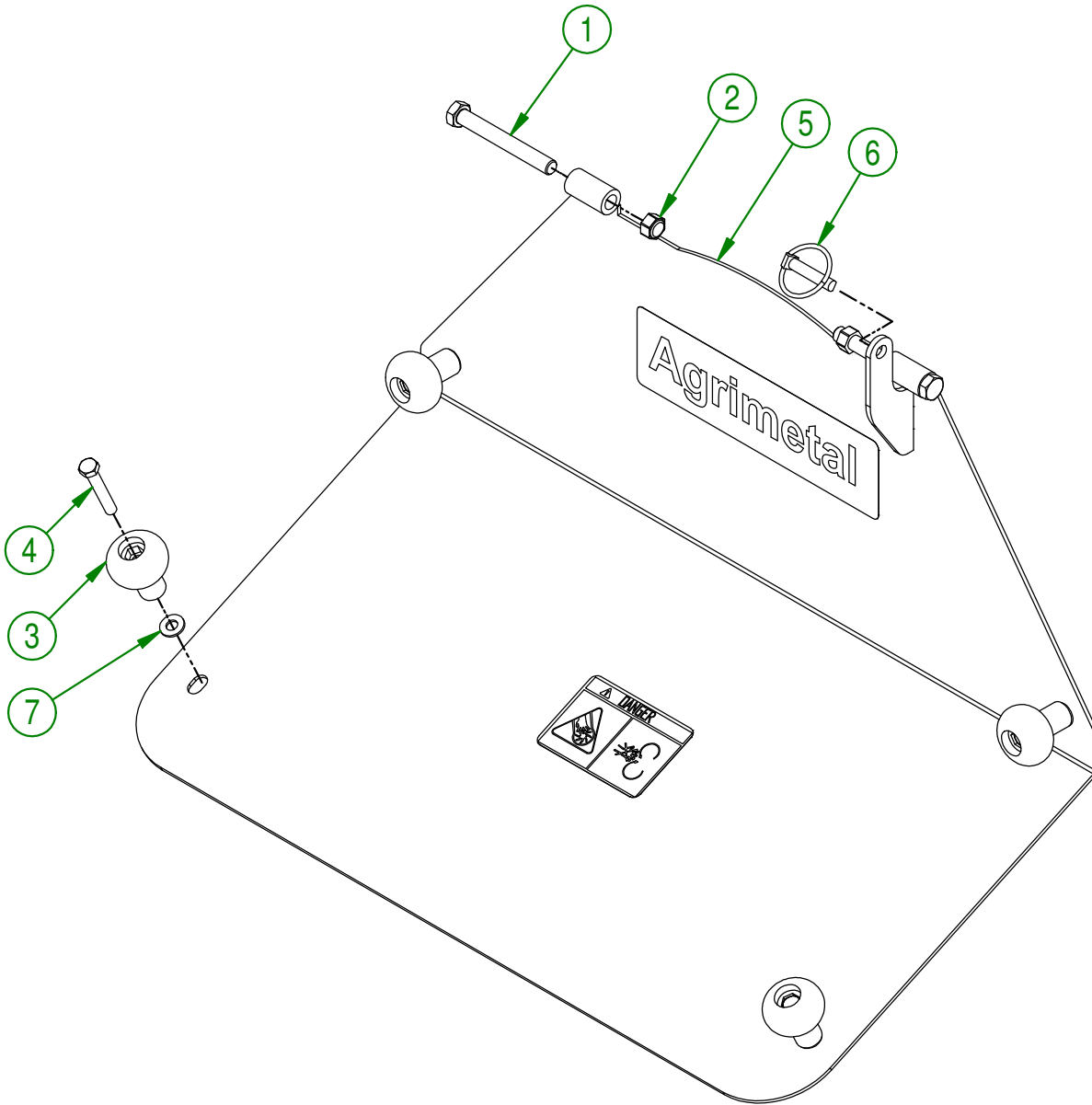

<b>AGRIMETAL</b>	
<b>IMPELLER ACCESS DOOR GROUP</b>	
CREATION : 07/12/17	ASSEMBLY : <b>84-57-0135</b>
REVISION : 28/12/17	AUTHOR : F.HÉLIE   Page 6 de 17

#	PART #	Qty	TITLE
1	80-50-0050	1	IMPELLER
2	NC01-94-0011	2	LOCK NUT 3/8-24
3	NC01-37-0121	2	HEX. BOLT GR8 ZINC 3/8-24 X 2 3/4" LG
4	NC02-32-0016	1	LOCK WASHER ZINC 5/8"
5	NC01-25-0395	1	HEX. BOLT GR5 ZINC 5/8-11 X 1 3/4" LG
6	80-04-0185	1	WASHER

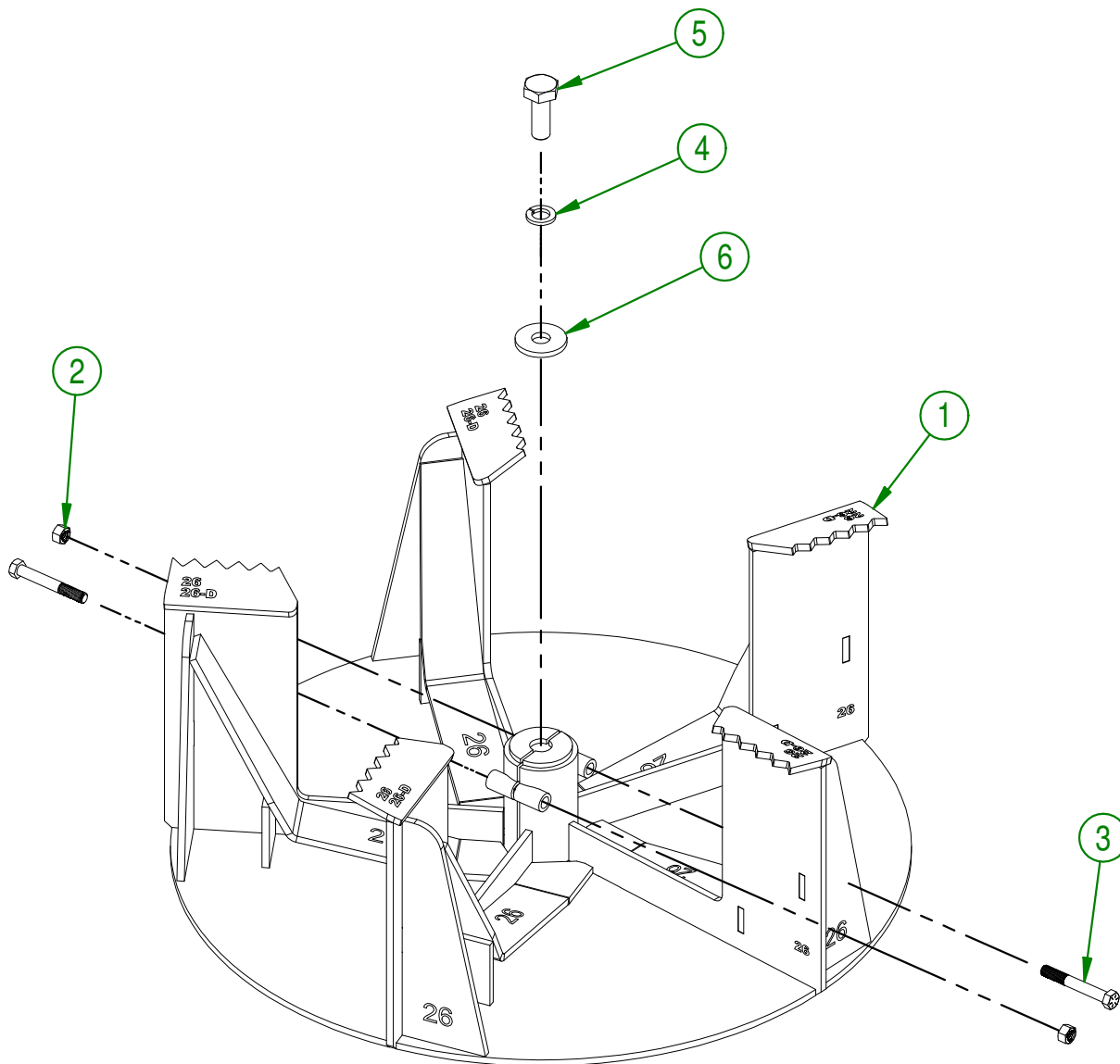

<b>AGRIMETAL</b>	
<b>IMPELLER GROUP</b>	
CREATION : 13/04/18	ASSEMBLY : <b>80-57-0426</b>
REVISION : 25/06/20	AUTHOR : F.HÉLIE
	Page 7 de 17

#	# PART	QTY	TITLE
1	NC14-75-0160	2	FLANGE BEARING UCF207-20 1 1/4" ID
2	84-50-0170	1	SPIRAL
3	NC02-25-0011	8	WASHER SAE ZINC 17/32 ID
4	NC01-17-0251	4	HEX. BOLT GR2 ZINC 1/2-13 X 2"
5	NC01-17-0250	4	HEX. BOLT GR2 ZINC 1/2-13 X 1 3/4"
6	NC02-32-0014	8	LOCK WASHER ZINC 1/2"
7	NC02-07-0020	8	HEX. NUT ZINC 1/2-13
8	84-04-0450	1	SPIRAL BEARING SHIM
9	NC14-55-0275	1	80A34 SPROCKET
10	NC01-29-0249	4	HEX. BOLT GR5 ZINC 1/2-20 X 1 1/2
11	NC01-94-0013	4	JAM NUT 1/2-20
12	84-51-0118	1	SPIRAL SHAFT (SPROCKET)
13	84-51-0155	1	SPIRAL SHAFT

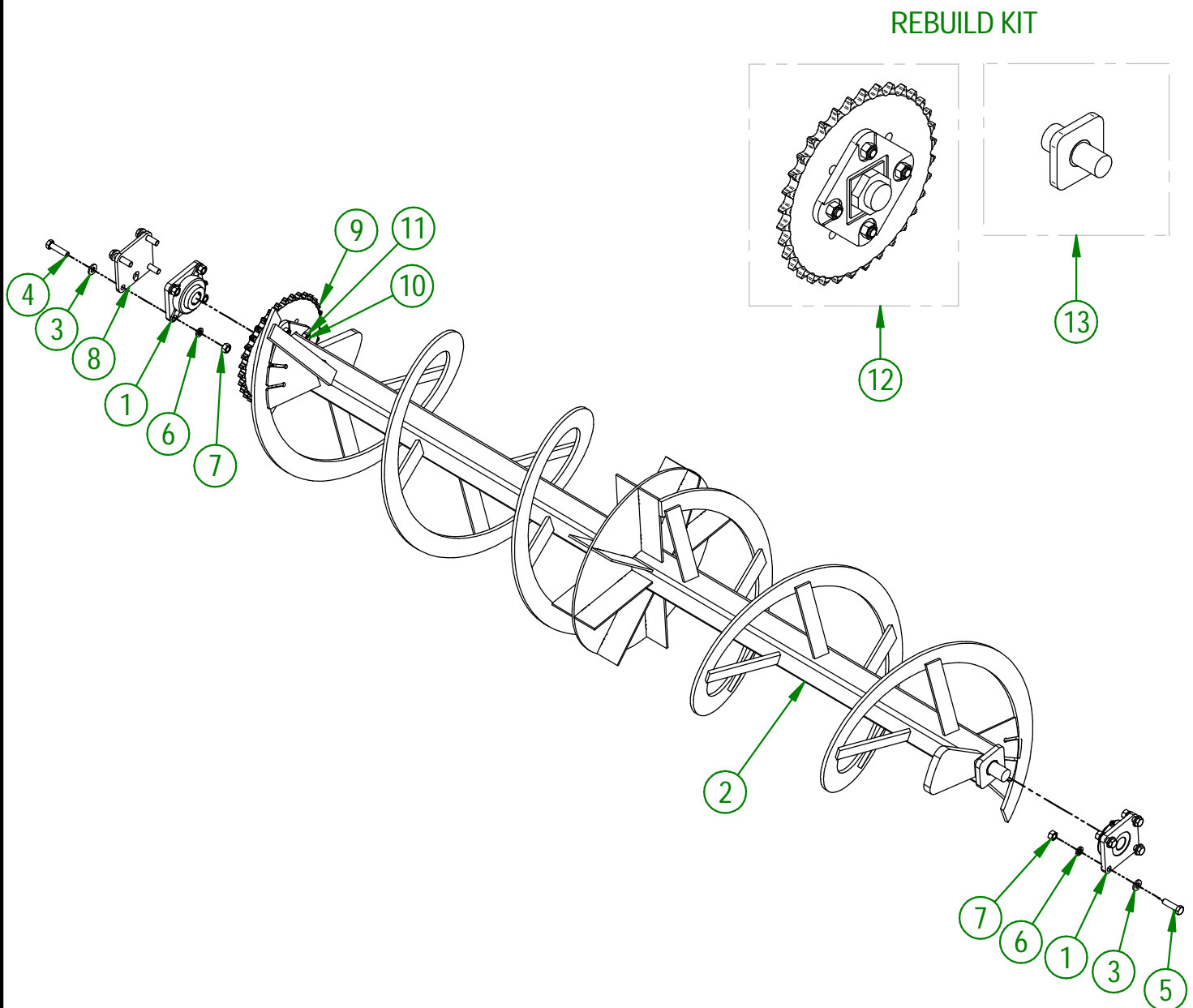

<b>AGRIMETAL</b>	
<b>SPIRAL GROUP</b>	
CREATION : 06/12/17	ASSEMBLY : <b>84-57-0180</b>
REVISION : 02/12/25	AUTHOR : F.HÉLIE

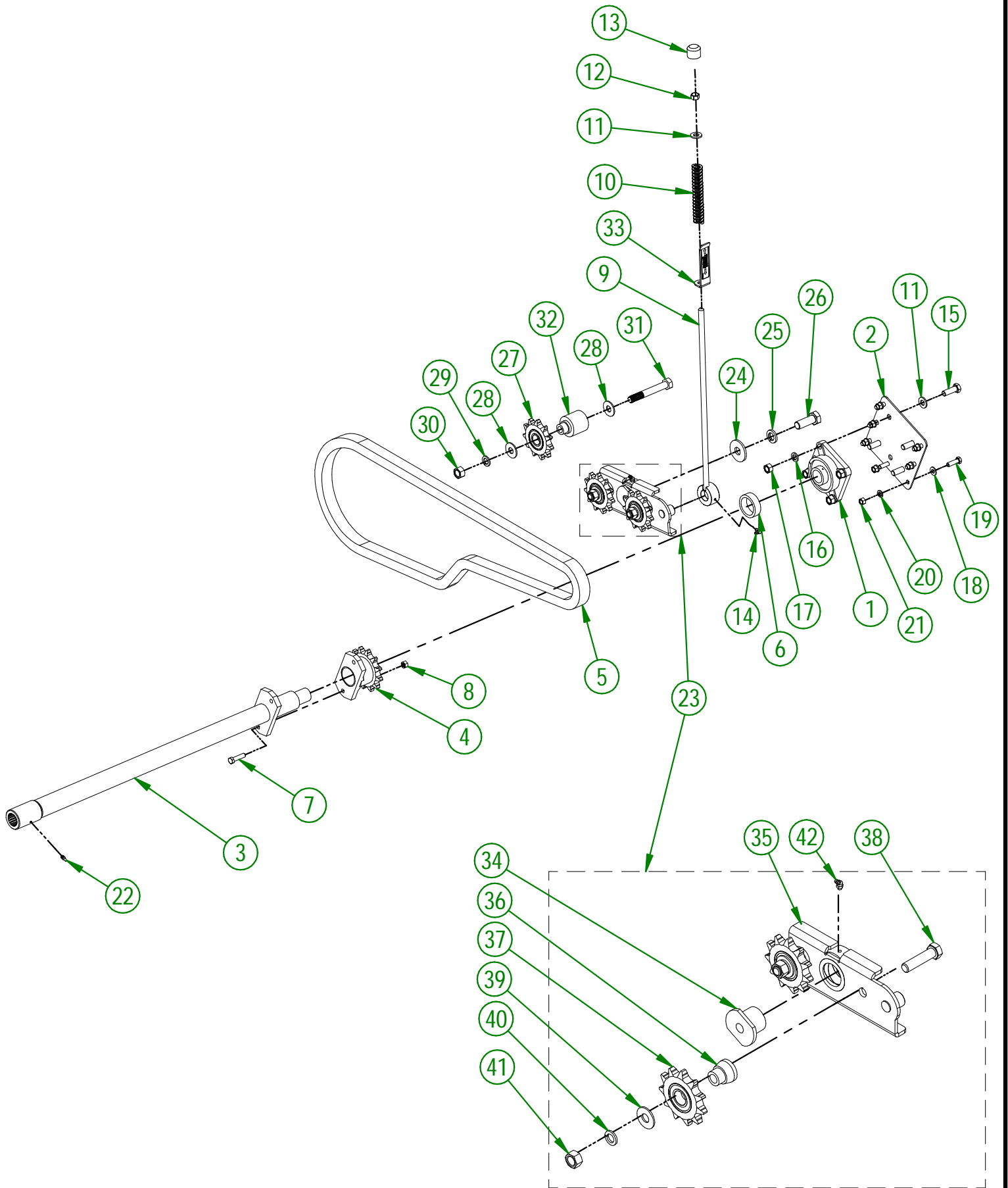

**AGRIMETAL**  
**SPIRAL DRIVE TRAIN GROUP**

CREATION : 07/12/17  
 REVISION : 24/02/22

ASSEMBLY : **84-57-0130**  
 AUTHOR : F.HÉLIE

84-57-0130

#	PART #	Qty	TITLE
1	NC14-75-0024	1	FLANGE BEARING 4 HOLES UCF207-20 1 1/4" DIA.
2	84-01-0905	1	COUNTER SHAFT BEARING SUPPORT
3	84-50-0165	1	SPIRAL DRIVE TRAIN
4	NC14-55-0276	1	80B12H SPROCKET
5	84-37-1005	1	CHAIN #80
6	84-24-0005	1	SPIRAL DRIVE TRAIN BUSHING
7	NC01-25-0116	1	HEX. BOLT GR5 ZINC 3/8-16 X 1 1/2"
8	NC01-93-0011	1	LOCK NUT 3/8-16
9	84-50-0140	1	THREADED ROD
10	NC13-86-0054	1	BLUE SPRING 1/2" ID X 1" OD X 6" LG
11	NC02-25-0011	5	WASHER SAE ZINC 17/32 ID
12	NC01-96-0014	1	NYLON-INSERT LOCKNUT ZINC 1/2-13
13	80-42-0110	1	THREADED ROD CAP
14	NC01-69-0787	1	GREASE FITTING STRAIGHT 1/4-28 X 90
15	NC01-17-0249	4	HEX. BOLT GR2 ZINC 1/2-13 X 1 1/2"
16	NC02-32-0014	4	LOCK WASHER ZINC 1/2"
17	NC02-07-0020	4	HEX. NUT ZINC 1/2-13
18	01-01-2485	7	FLAT WASHER 14 GA X 13/16"OD X 25/64" ID
19	NC01-17-0115	7	HEX. BOLT GR2 ZINC 3/8-16 X 1 1/4"
20	NC02-32-0012	7	LOCK WASHER ZINC 3/8"
21	NC02-07-0018	7	HEX. NUT ZINC 3/8-16
22	NC01-69-0785	1	STRAIGHT GREASE FITTING 1/4-28
23	81-55-0400	1	CHAIN TENSIONER GROUP
24	80-04-0170	1	WASHER
25	NC02-32-0017	1	LOCK WASHER ZINC 3/4"
26	NC01-25-0467	1	HEX. BOLT GR2 ZINC 3/4-10 X 2 " LG.
27	81-55-0005	1	CHAIN TENSIONER SPROCKET
28	NC02-22-0013	2	WASHER ZINC 5/8 ID X 1 1/2 OD
29	NC02-32-0016	1	LOCK WASHER ZINC 5/8"
30	NC02-10-0022	1	HEX. NUT ZINC 5/8-18
31	NC01-17-0406	1	HEX. BOLT GR2 ZINC 5/8-11 X 4 1/2"
32	81-21-0002	1	CHAIN TENSIONER BUSHING
33	83-57-0160	1	ADJUSTEMENT INDICATOR

81-55-0400

#	PART #	Qty	TITLE
34	88-13-0005	1	CHAIN TENSIONER BUSHING
35	81-50-5005	1	CHAIN TENSIONER
36	81-21-0020	2	CHAIN TENSIONER BUSHING
37	81-55-0005	2	CHAIN TENSIONER SPROCKET
38	NC01-17-0398	2	HEX. BOLT GR2 NC ZINC 5/8-11 X 2 1/2"
39	NC02-22-0013	2	WASHER ZINC 5/8 ID X 1 1/2 OD
40	NC02-32-0016	2	LOCK WASHER ZINC 5/8"
41	NC02-10-0022	2	HEX. NUT ZINC 5/8-18
42	NC01-69-0786	1	GREASE FITTING 1/4-28 X 45

#	PART #	Qty	TITLE
1	01-01-2485	4	FLAT WASHER 14 GA X 13/16"OD X 25/64" ID
2	NC01-17-0114	2	HEX. BOLT GR2 ZINC 3/8-16 X 1"
3	NC01-96-0011	2	NYLON NUT 3/8-16
4	84-57-0155	1	CHAIN GUARD

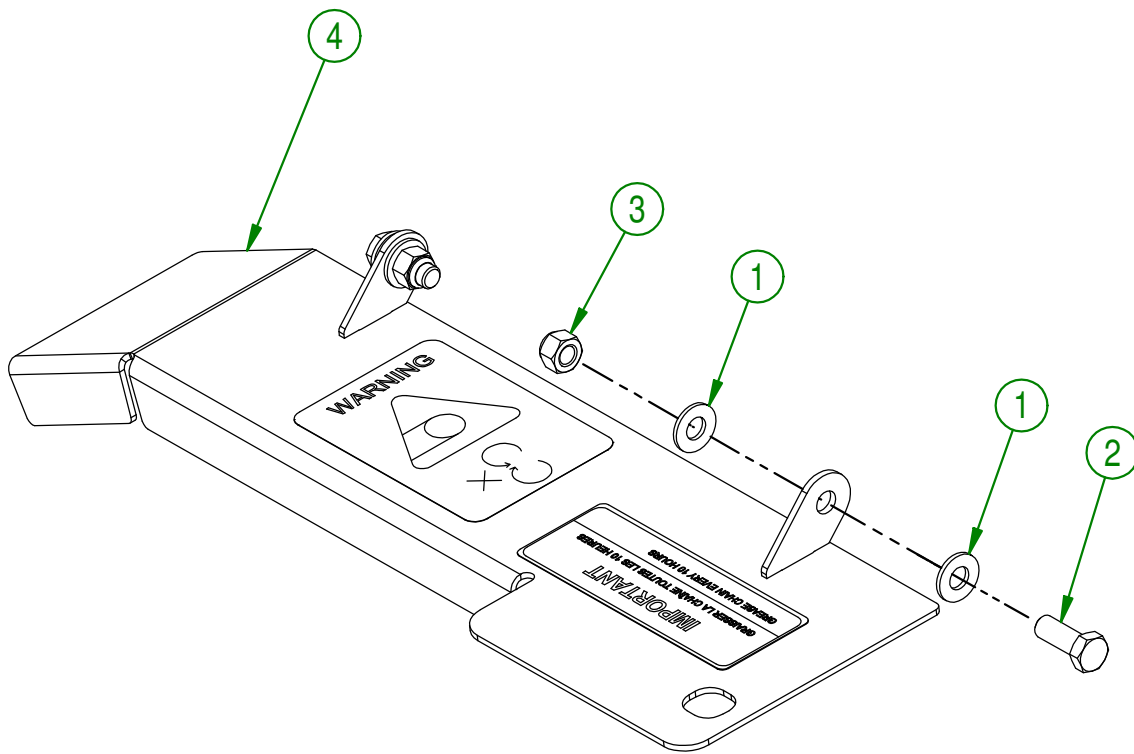

<b>AGRIMETAL</b>	
<b>CHAIN GUARD GROUP</b>	
CREATION : 07/12/17	ASSEMBLY : <b>84-57-0160</b>
REVISION : 18/11/19	AUTHOR : F.HÉLIE Page 11 de 17

#	PART #	Qty	TITLE
1	84-55-0010	1	GEARBOX
2	NC02-25-0011	14	WASHER SAE ZINC 17/32 ID
3	NC02-32-0014	12	LOCK WASHER ZINC 1/2"
4	NC01-33-0248	8	HEX. BOLT .GR8 NC ZINC 1/2-13 X 1 1/4"
5	80-41-0135	1	PTO GUARD STEEL CABLE
6	NC01-64-0005	2	OVAL SLEEVE (ALUMINUM)
7	80-41-0900	1	IMPELLER KEY
8	NC13-25-0019	1	BLACK TIE RAP
9	NC13-50-0110	1	IMPORTANT/NOTICE PTO POSTER
10	81-57-0040	1	PTO GUARD
11	80-34-0030	1	PTO SHAFT T60
12	84-01-0095	1	PTO GUARD SUPPORT
13	80-04-0485	1	GEARBOX BRACE
14	80-04-0480	1	GEARBOX BRACE
15	NC01-33-0249	4	CAP SCREW GR8 NC ZINC 1/2-13 X 1 1/2" LG
16	NC02-07-0020	4	HEX. NUT ZINC 1/2-13
17	NC01-63-0027	1	HAIRPIN COTTER
18	84-04-0660	2	GEARBOX SPACER

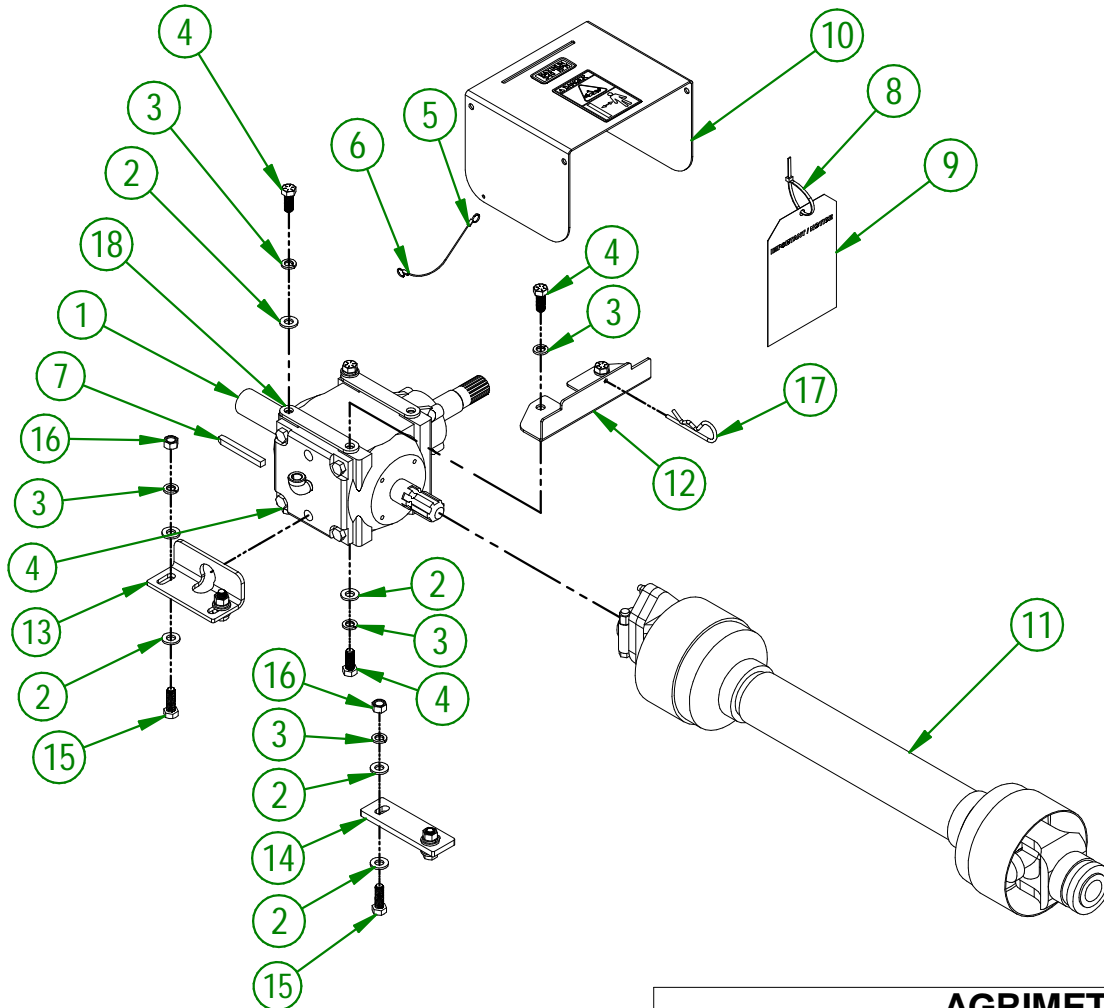

**AGRIMETAL**  
GEARBOX GROUPING

CREATION : 06/12/17  
REVISION : 25/05/22

ASSEMBLY : **84-57-0100**  
AUTHOR : F.HÉLIE

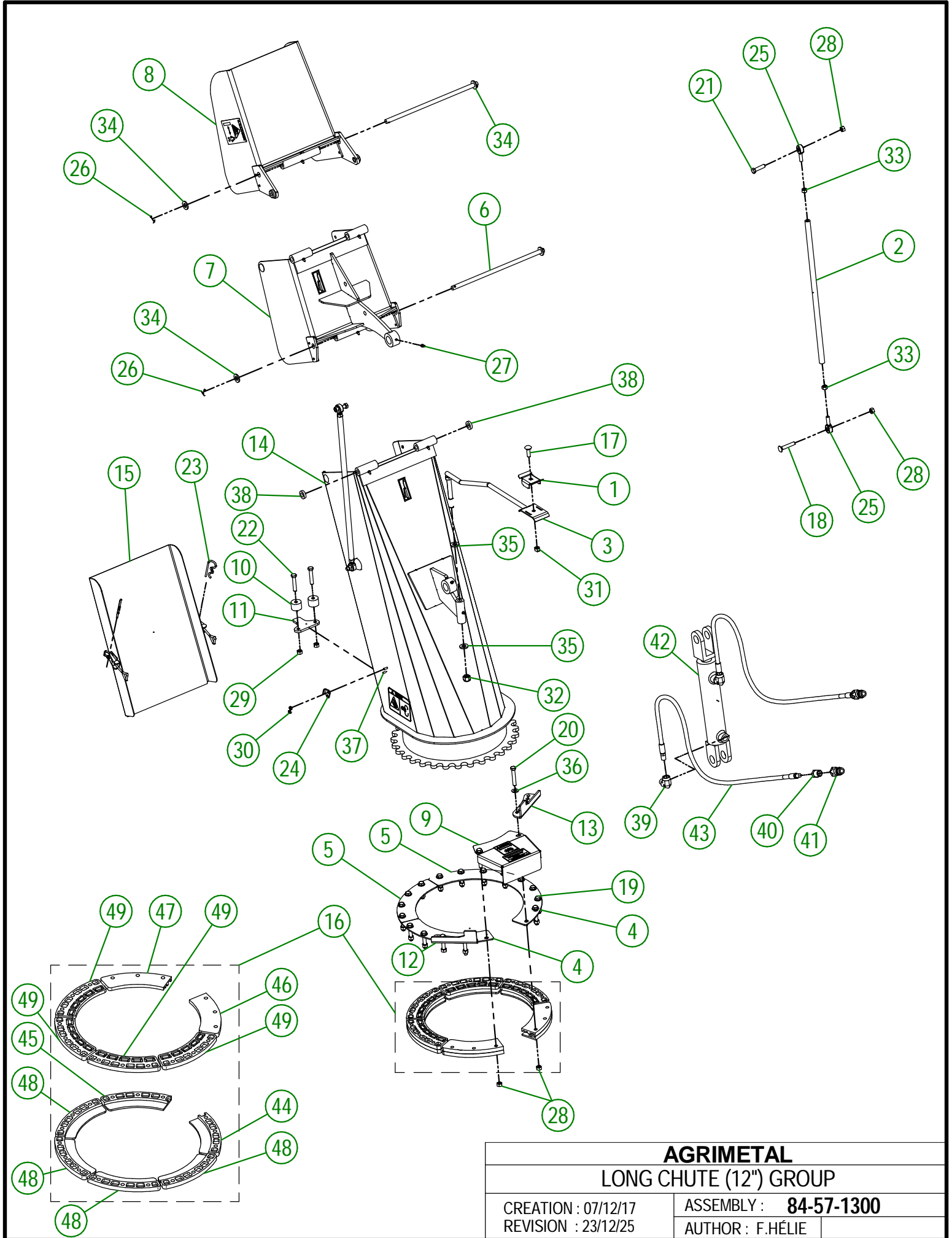

**AGRIMETAL**

**LONG CHUTE (12") GROUP**

CREATION : 07/12/17  
 REVISION : 23/12/25

ASSEMBLY : **84-57-1300**  
 AUTHOR : F.HÉLIE

## 84-57-1300

#	PART #	Qty	TITLE
1	48-01-7530	1	HYDRAULIC HOSE SUPPORT
2	48-13-0600	2	CHUTE ROD (DOUBLE)
3	48-50-1030	1	HYDRAULIC HOSE SUPPORT
4	80-01-1010	2	BRACE
5	80-01-1015	2	BRACE
6	80-20-0260	2	PIVOT
7	80-57-0312	1	CHUTE (MIDDLE SECTION)
8	80-57-0322	1	CHUTE (TOP SECTION)
9	80-57-0550	1	SPROCKET GUARD GROUP "STICKER INCLUDED"
10	81-21-0040	2	ADJUSTABLE STOPPER SPACER
11	84-04-0170	1	STOPPER
12	84-04-0175	1	ADJUSTABLE STOPPER
13	84-04-0177	1	ADJUSTABLE STOPPER
14	84-57-1305	1	CHUTE (BOTTOM SECTION)
15	84-57-1310	1	CHUTE DOOR
16	84-57-1330	1	GUIDE CHUTE GROUP
17	NC01-04-0110	1	CARR. BOLT GR2 ZINC 3/8-16 X 1 1/4"
18	NC01-07-0113	2	CARR. BOLT GR5 ZINC 3/8-16 X 2" LG
19	NC01-17-0118	14	HEX. BOLT GR2 ZINC 3/8-16 X 2"
20	NC01-17-0119	4	HEX. BOLT GR2 ZINC 3/8-16 X 2 1/4"
21	NC01-25-0116	2	HEX. BOLT GR5 ZINC 3/8-16 X 1 1/2"
22	NC01-37-0118	2	HEX. BOLT GR8 ZINC 3/8-24 X 2"
23	NC01-63-0026	2	COTTER PIN ZC 5/32" X 3"
24	NC01-63-0052	2	ADJUSTABLE LATCH (STRIKE)
25	NC01-67-0304	4	ROD END 3/8-24
26	NC01-69-0139	4	COTTER PIN ZINC 1/8" X 3/4"
27	NC01-69-0785	9	STRAIGHT GREASE FITTING 1/4-28
28	NC01-93-0011	22	LOCK NUT 3/8-16
29	NC01-94-0011	2	LOCK NUT 3/8-24
30	NC01-96-0006	4	NYLON NUT ZINC 3/16
31	NC01-96-0011	1	NYLON NUT 3/8-16
32	NC01-96-0014	1	NYLON-INSERT LOCKNUT ZINC 1/2-13
33	NC02-10-0018	4	NUT 3/8-24
34	NC02-25-0011	4	WASHER SAE ZINC 17/32 ID
35	NC02-25-0011	2	WASHER SAE ZINC 17/32 ID
36	NC02-26-1525	18	WASHER INOX .406" D.I. X .815" D.E.
37	NC02-40-0080	4	MACHINE SCREWS SQUARE SOCKET #10-24 X 1/2" LG
38	NC13-15-0334	2	PIVOT WASHER
39	NC13-45-0038	2	ELBOW 90 3/8 FEM. NPT X 3/8 MALE NPT
40	NC13-45-0153	2	HEX. REDUCER 1/4 NPT X 1/2 NPT
41	NC13-45-0369	2	QUICK COUPLER 1/2-14 NPTF
42	NC13-45-0404	1	HYDRAULIC CYLINDER 6"
43	NC17-02-0329	2	HYDRAULIC HOSE (87" LG)

84-57-1330

#	PART #	Qty	TITLE
44	80-42-0305	1	CHUTE GUIDE (UNDER)
45	80-42-0310	1	CHUTE GUIDE (UNDER)
46	80-42-0315	1	CHUTE GUIDE (TOP)
47	80-42-0320	1	CHUTE GUIDE (TOP)
48	NC17-46-0027	4	CHUTE GUIDE (UNDER)
49	NC17-46-0028	4	CHUTE GUIDE (TOP)

#	PART #	Qty	TITLE
1	48-01-7527	1	HYDRAULIC HOSE SUPPORT
2	48-50-1025	1	HYDRAULIC ENGINE SPROCKET
3	80-13-0100	2	HYDRAULIC RESTRICTOR
4	80-45-0000	2	HEX. REDUCER 1/4 NPT X 1/2 NPT
5	81-01-7600	1	HYDRAULIC HOSE SUPPORT
6	NC01-07-0111	1	CARR. BOLT GR5 ZINC 3/8-16 X 1 1/2"
7	NC01-17-0115	2	HEX. BOLT GR2 ZINC 3/8-16 X 1 1/4"
8	NC01-33-0113	4	HEX.BOLT GR8 ZINC 3/8-16 X 3/4"
9	NC01-45-0184	1	HEX. BOLT GR8.8 ZINC 8MM X 20MM
10	NC01-96-0011	1	NYLON NUT 3/8-16
11	NC02-07-0018	2	HEX. NUT ZINC 3/8-16
12	NC02-26-0504	1	WASHER
13	NC02-26-1525	2	WASHER INOX .406" D.I. X .815" D.E.
14	NC02-32-0011	1	LOCK WASHER ZINC 5/16"
15	NC02-32-0012	6	LOCK WASHER ZINC 3/8"
16	NC02-44-0103	2	SET SCREW 5/16-18 X 3/8"
17	NC13-45-0367	2	45°-7/8-14 MALE O RING X 1/2 FEM.TOUR.NPT PT
18	NC13-45-0369	2	QUICK COUPLER 1/2-14 NPTF
19	NC13-45-0378	2	HYDRAULIC RESTRICTOR BUSHING
20	NC14-45-0156	1	HYDRAULIC MOTOR
21	NC17-02-0328	2	HYDRAULIC HOSE (63" LG)
22	NC17-46-0031	1	HYDRAULIC MOTOR BUSHING

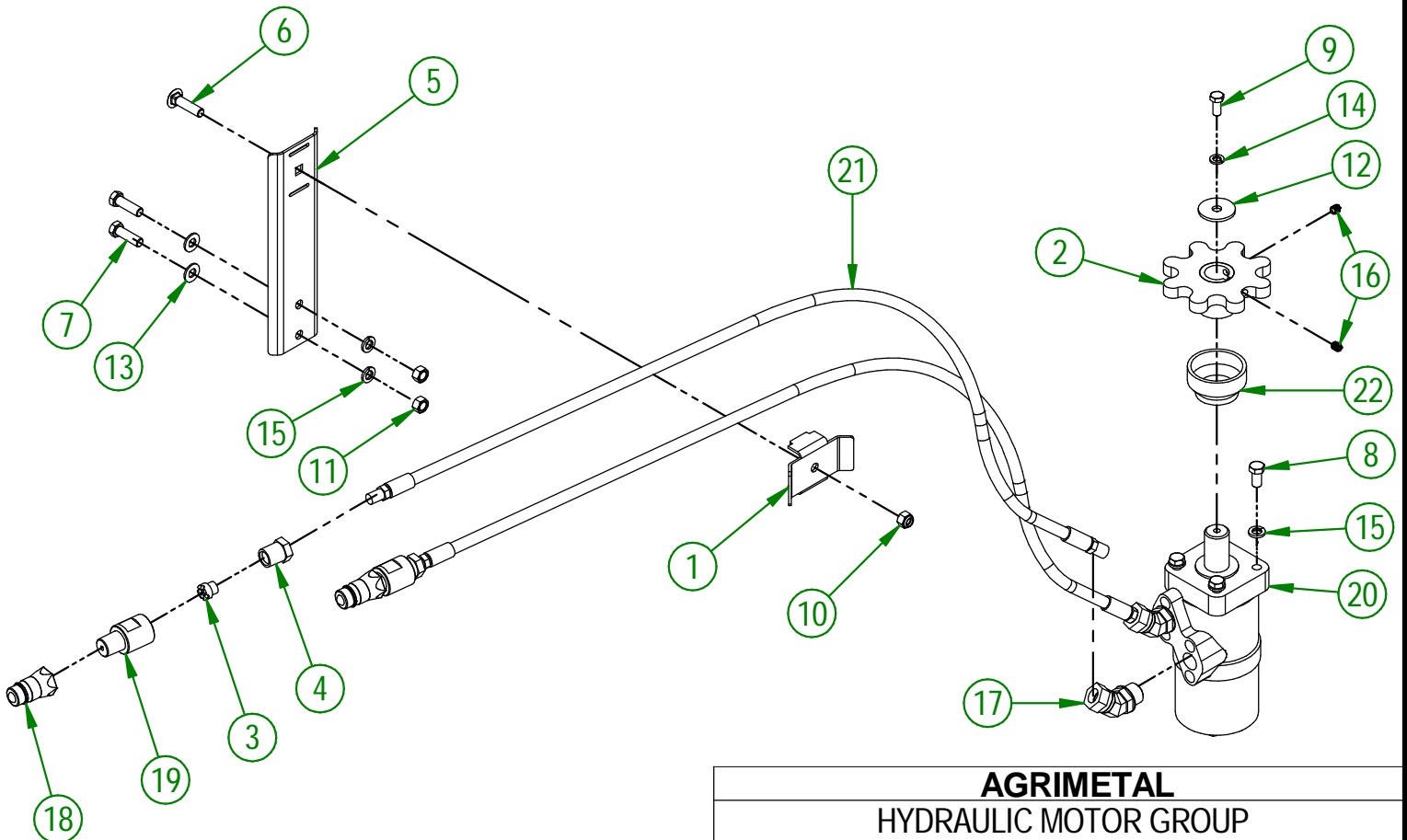

**AGRIMETAL**  
**HYDRAULIC MOTOR GROUP**

CREATION : 05/08/19  
 REVISION : 25/03/26

ASSEMBLY : **84-57-0410**  
 AUTHOR : F.HÉLIE

#	PART #	Qty	TITLE
1	NCI3-30-0237	1	PLASTIC TUBE FOR OPERATOR'S MANUAL
2	NC02-22-0008	2	WASHER ZINC 5/16"
3	NC01-17-0007	2	HEX. BOLT GR2 ZINC 1/4-20 X 1 1/4"
4	NC01-96-0009	2	NYLON-INSERT LOCKNUT ZINC 1/4-20
5	81-57-0030	1	SET OF 6 SHEAR BOLT WITH NUT
6	84-98-0520	1	ENGLISH OPERATOR'S MANUAL (MS2692-i, MS2482-i)

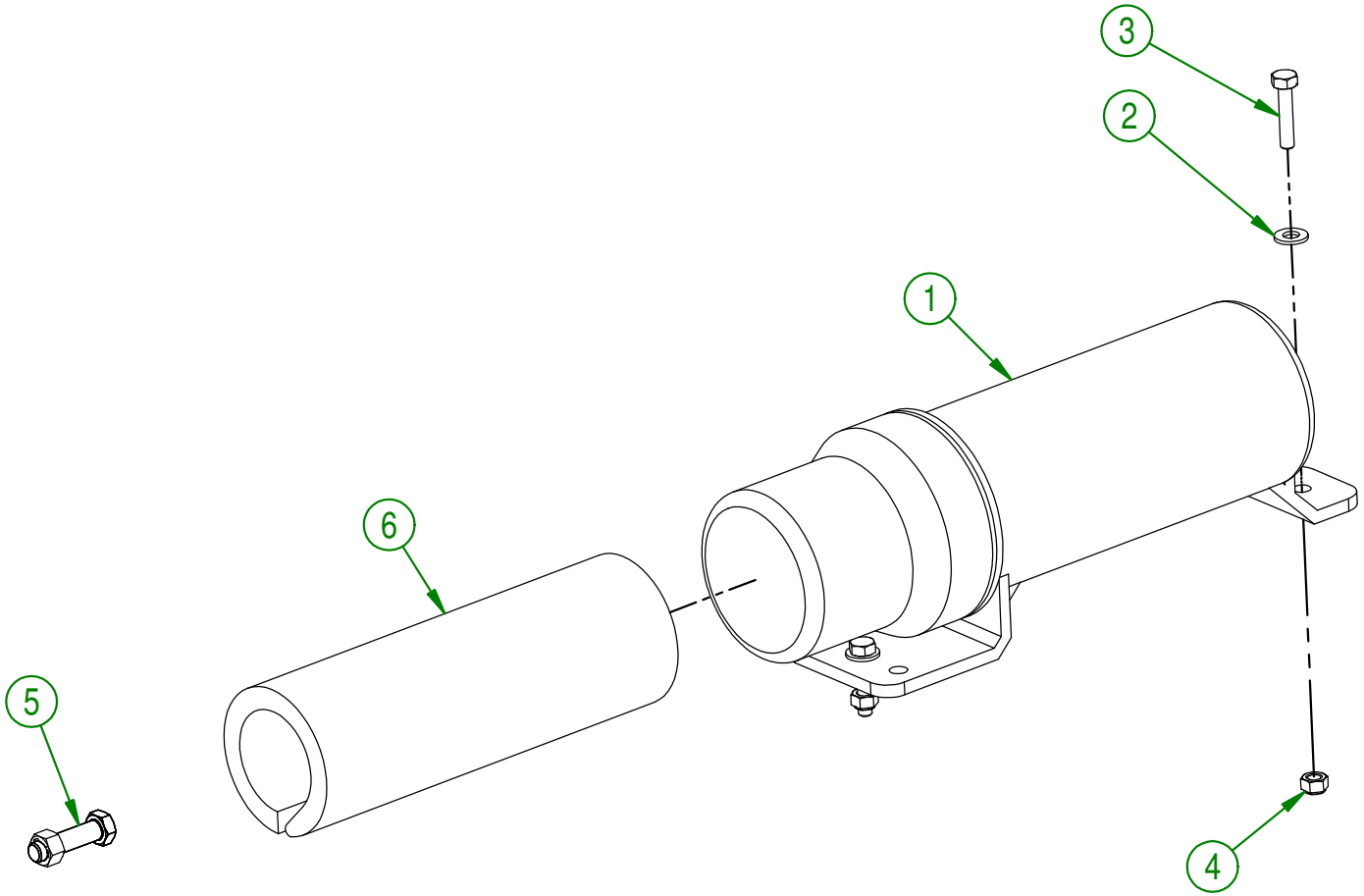

<b>AGRIMETAL</b>	
<b>OPERATOR'S MANUAL TUBE GROUP</b>	
CREATION : 03/01/18	ASSEMBLY : <b>84-57-1320</b>
REVISION : 03/01/18	AUTHOR : F.HÉLIE Page 16 de 17

#	PART #	QTY	TITLE
1	NCI3-33-0005	1	STICKER MAXIMUM 540 RPM
2	NCI3-33-0187	1	STICKER DANGER (PTO AND PERSON)
3	NCI3-33-0283	1	STICKER DANGER (PERSON AND CHAIN DRIVE)
4	NCI3-33-0249	4	STICKER DANGER
5	NCI3-33-0024	6	STICKER GREASE HERE
6	NCI3-33-0192	2	STICKER (PROJECTION RISK)
7	NCI3-33-0326	1	STICKER DANGER (HAND)
8	NCI3-33-0327	1	STICKER END ROTATION ADJUSTMENT
9	NCI3-33-0035	3	STICKER AGRIMETAL
10	NCI3-50-0086	1	SERIAL NUMBER PLATE
11	NCI3-33-0274	2	STICKER DANGER
12	NCI3-33-0281	1	STICKER SHEAR BOLT
13	NCI3-33-0248	1	STICKER IMPORTANT 4 1/4 INCHES 110mm
14	NCI3-33-0241	1	STICKER MAX-SNOW COMMERCIAL
15	NCI3-33-0317	1	STICKER GREASE DRIVE LINE TELESCOPIC SHAFT
16	NCI3-33-0189	1	STICKER DANGER (PERSON AND CHAIN DRIVE)
17	NCI3-33-0316	1	STICKER 2692-i

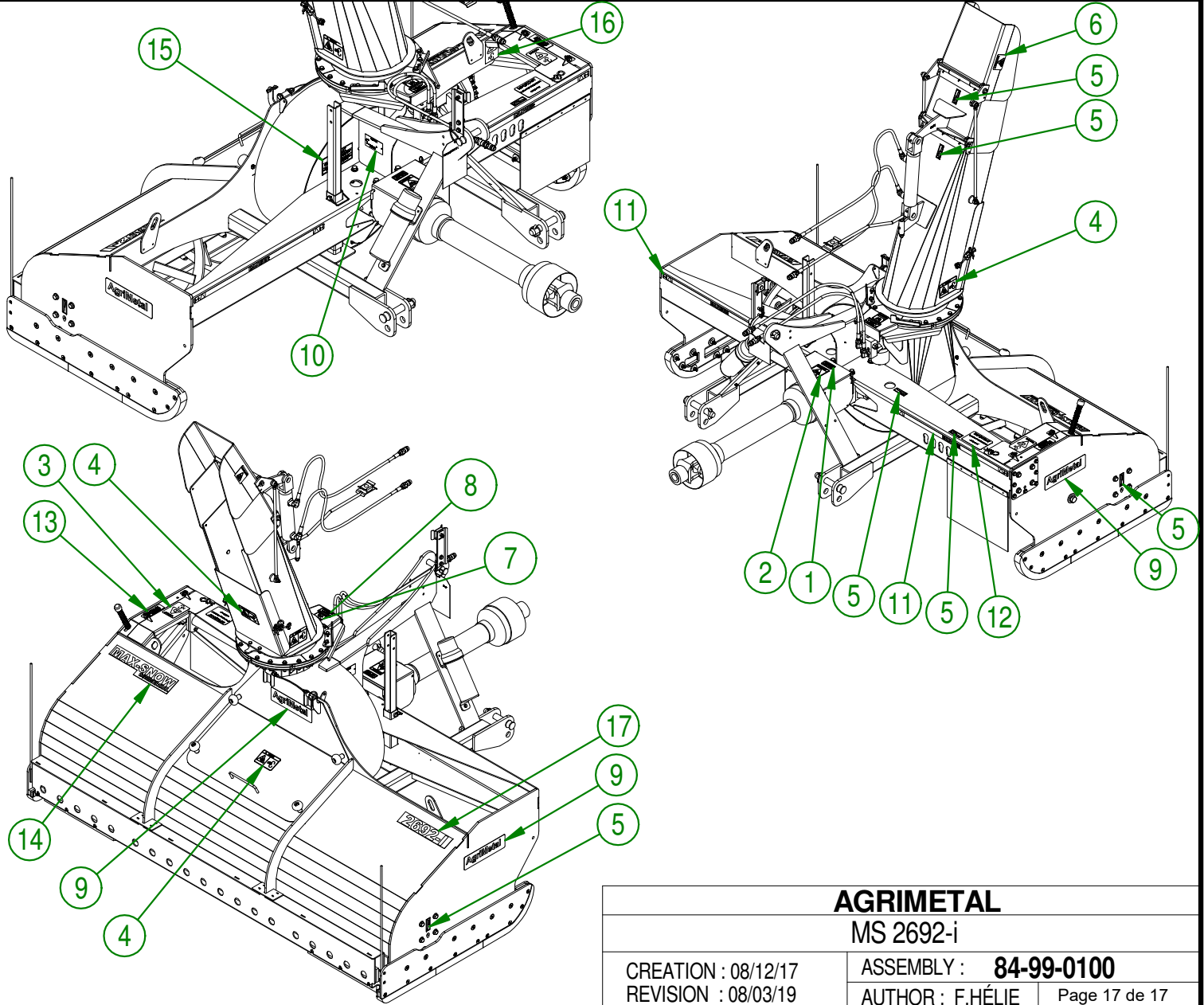

**AGRIMETAL**

MS 2692-i

CREATION : 08/12/17  
 REVISION : 08/03/19

ASSEMBLY : **84-99-0100**

AUTHOR : F.HÉLIE Page 17 de 17