

AgriMetal

PART LIST

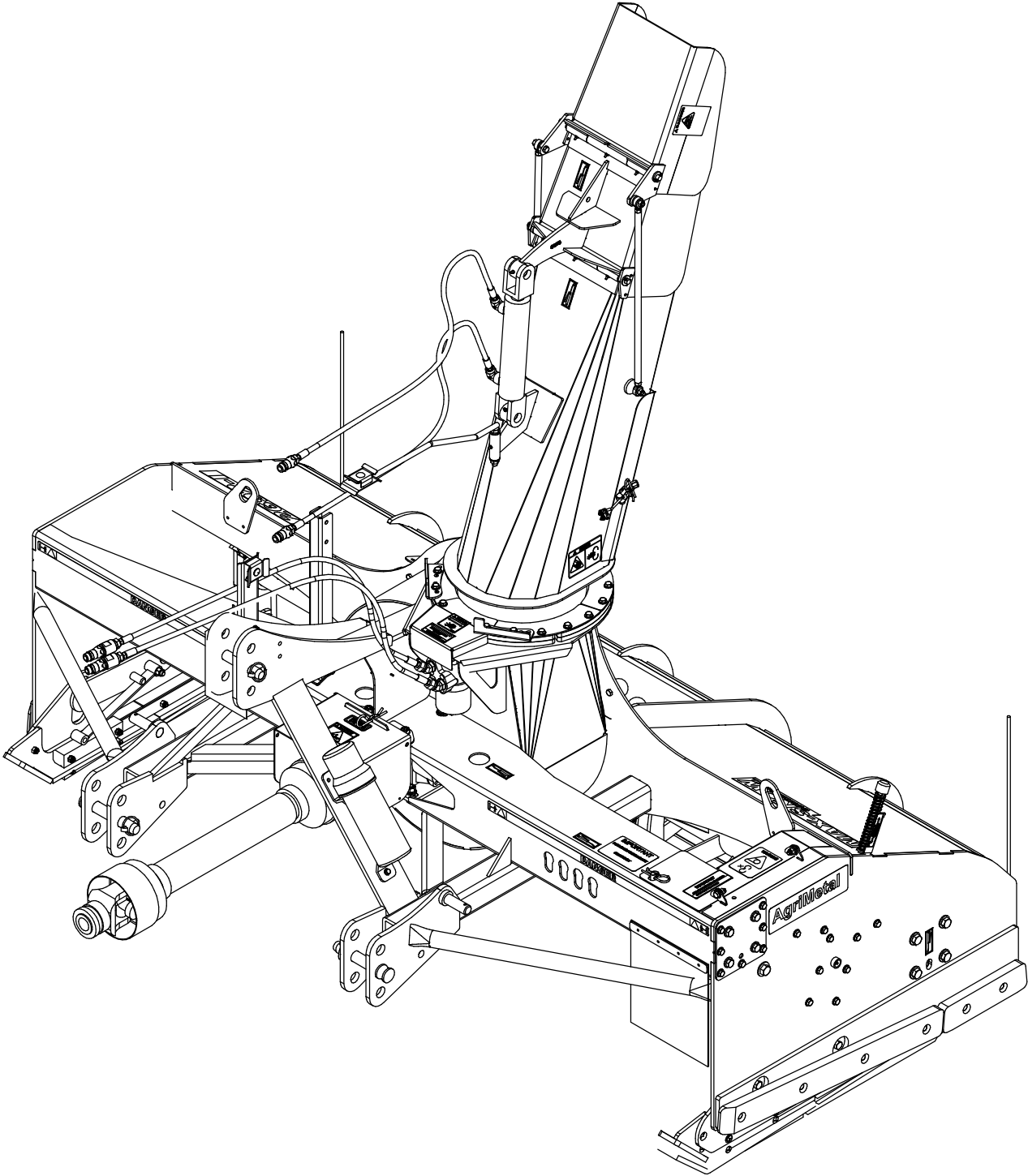

MS-2692-I

84-57-0229

#	PART #	Qty	TITLE
1	84-20-0151	2	KNIFE (#450 HARDNESS STEEL)
2	84-50-0226	1	FRONT RIGHT FLOATING SKATE (QT-450)
3	NC01-09-0039	12	PLOW BOLT GR5 5/8-11 X 1 1/2" LG
4	NC01-93-0016	12	LOCK NUT ZINC 5/8-11
5	84-42-0340	2	WEAR STRIP FOR SPRING BLADE
6	NC01-96-0011	12	NYLON NUT 3/8-16
7	84-50-0280	1	BACK RIGHT FLAOTING SKATE (QT-450)
8	84-50-0228	1	FRONT LEFT FLOATING SKATE (QT-450)
9	84-50-0283	1	BACK LEFT FLAOTING SKATE (QT-450)
10	NC01-09-0011	8	SQUARE-NECK FLAT HEAD PLOW BOLT 3/8-16 X 1 1/4"
11	NC02-48-0539	4	STAINLESS FLAT HEAD SOCKET CAP SREW 3/8-16 X 2 3/4"

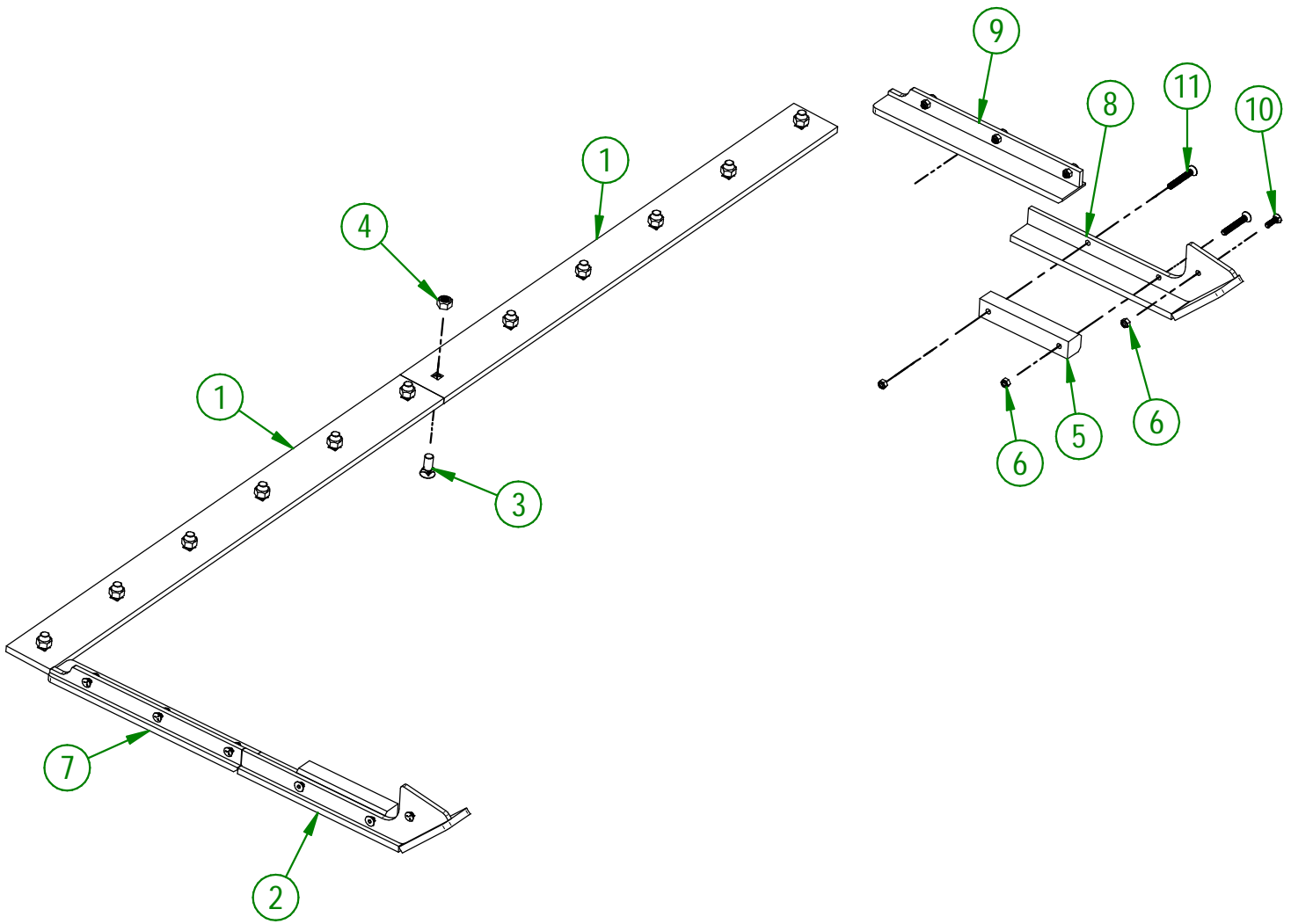

AGRIMETAL	
SET OF KNIVES (QT-450)	
CREATION : 02/03/23	ASSEMBLY : 84-57-0229
REVISION : 30/03/23	AUTHOR : D. CHASSÉ

84-57-0290

#	PART #	Qty	TITLE
1	NC02-48-0564	12	FLAT HEAD SOCKET CAP SCREW STAINLESS 5/8-11 X 2" LG
2	NC01-93-0016	12	LOCK NUT ZINC 5/8-11
3	84-50-0115	2	KNIFE BRACE (TOP)
4	84-42-0272	1	LEFT KNIFE (UHMW)
5	84-42-0275	1	RIGHT KNIFE (UHMW)
6	84-16-0010	2	FLOATING SKATE BRACE
7	84-42-0530	2	FLOATING SKATE (UHMW)
8	NC01-09-0016	10	SQUARE-NECK FLAT HEAD PLOW BOLT 3/8-16 X 2 1/2 LG
9	NC01-96-0011	10	NYLON NUT 3/8-16
10	84-13-0150	12	KNIFE RING

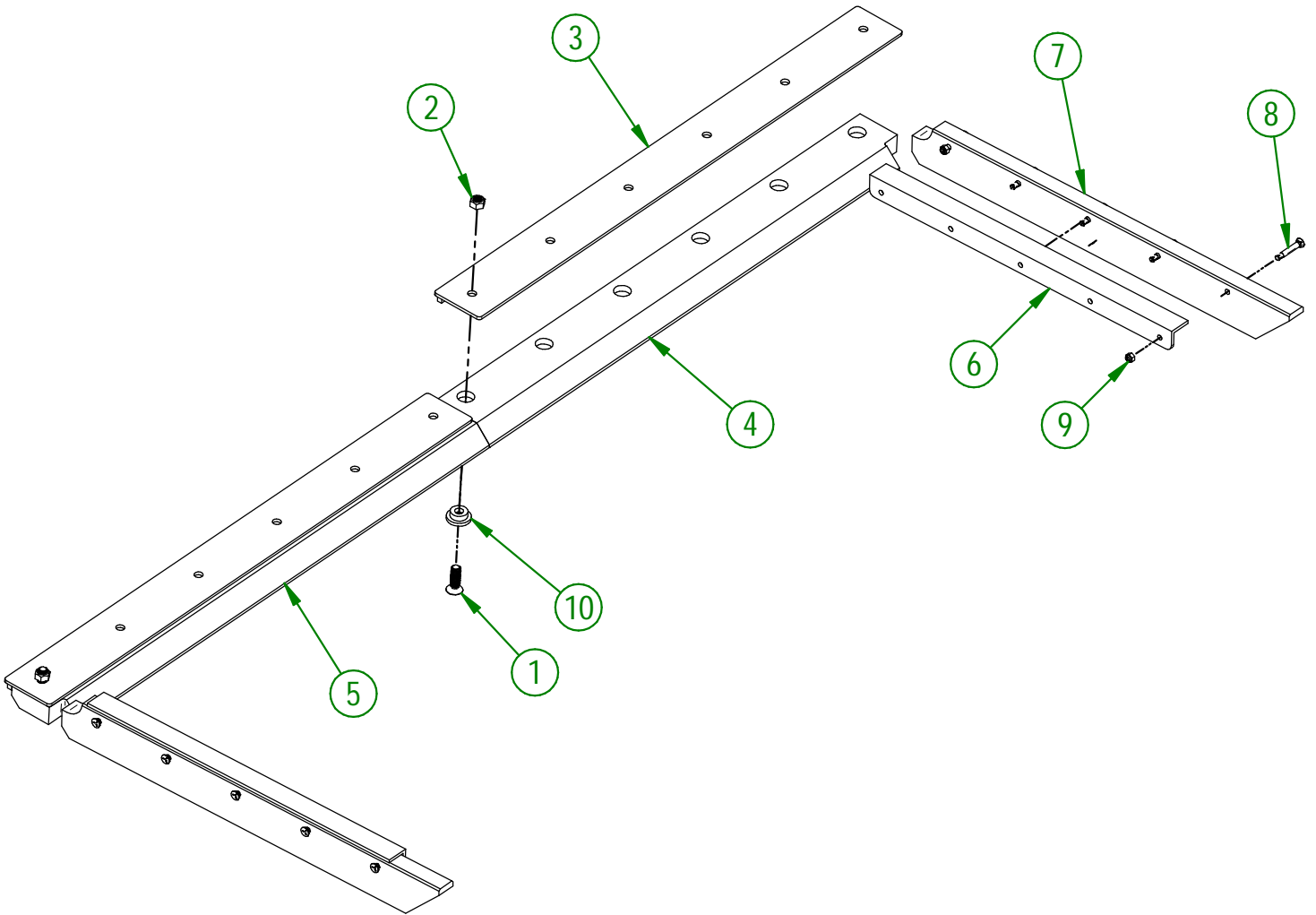

AGRIMETAL

SET OF KNIVES (UHMW)

CREATION : 03/03/23
 REVISION : 22/01/26

ASSEMBLY : **84-57-0290**
 AUTHOR : D. CHASSÉ

84-57-0239

#	PART #	Qty	TITLE
1	84-20-0156	2	KNIFE (STAINLESS STEEL)
2	NC02-48-0562	12	FLAT HEAD SOCKET CAP SCREW STAINLESS 5/8-11 X 1 1/2"
3	NC01-93-0016	12	LOCK NUT ZINC 5/8-11
4	84-42-0340	2	WEAR STRIP FOR SPRING BLADE
5	84-50-0290	1	FRONT RIGHT FLOATING SKATE (S/S)
6	84-50-0293	1	FRONT LEFT FLOATING SKATE (S/S)
7	84-50-0295	1	BACK RIGHT FLAOTING SKATE (S/S)
8	84-50-0298	1	BACK LEFT FLAOTING SKATE (S/S)
9	NC01-09-0011	8	SQUARE-NECK FLAT HEAD PLOW BOLT 3/8-16 X 1 1/4"
10	NC02-48-0539	4	STAINLESS FLAT HEAD SOCKET CAP SREW 3/8-16 X 2 3/4"
11	NC01-96-0011	12	NYLON NUT 3/8-16

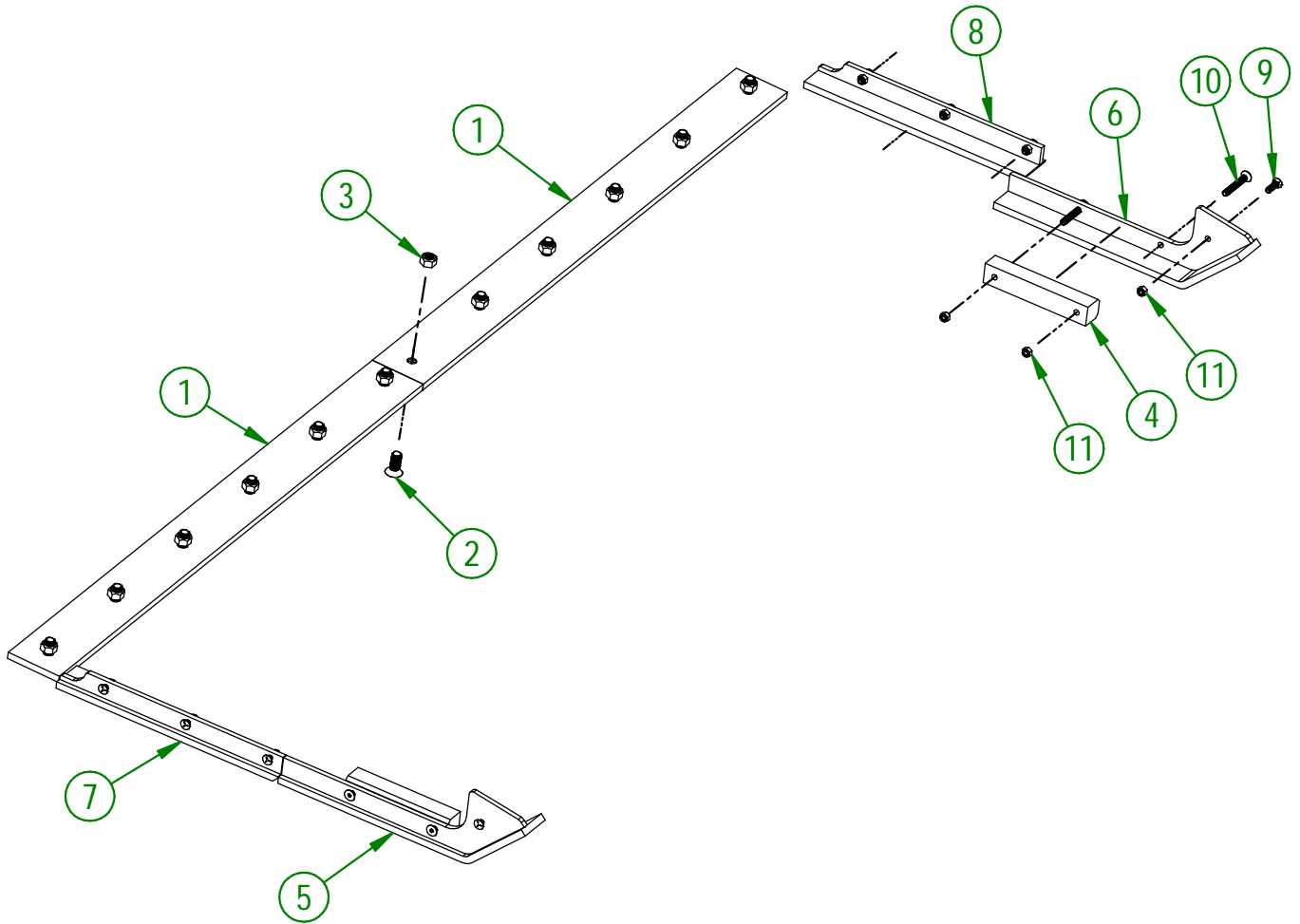

AGRIMETAL	
SET OF KNIVES (STAINLESS)	
CREATION : 03/03/23	ASSEMBLY : 84-57-0239
REVISION : 30/03/23	AUTHOR : D. CHASSÉ

#	PART #	Qty	TITLE
1	84-01-9155	2	COLLAR SUPPORT GUIDE ROD CLAMPING
2	84-20-9150	1	HYDRAULIC SKI PLATE
3	84-25-0000	5	HYDRAULIC SKI PIVOT WEAR RING
4	84-50-9150	5	ADJUSTABLE SKI RACK
5	84-50-9155	1	HYDRAULIC SKI
6	84-50-9160	2	HYDRAULIC CYLINDER SUPPORT
7	84-50-9165	1	HYDRAULIC CYLINDER REINFORCEMENT
8	NC01-25-0114	4	HEX. BOLT GR5 ZINC 3/8-16 X 1"
9	NC01-25-0115	20	HEX. BOLT GR5 ZINC 3/8-16 X 1 1/4"
10	NC01-25-0116	8	HEX. BOLT GR5 ZINC 3/8-16 X 1 1/2"
11	NC01-25-0398	5	HEX. BOLT GR5 ZINC 5/8-11 X 2 1/2" LG
12	NC01-69-0785	4	STRAIGHT GREASE FITTING 1/4-28
13	NC01-93-0010	12	LOCK NUT ZINC 5/16-18
14	NC01-93-0011	12	LOCK NUT 3/8-16
15	NC01-96-0016	5	NYLON INSERT NUT 5/8-11
16	NC02-25-0009	12	FLAT WASHER 14 GA X 13/16"OD X 25/64" ID
17	NC02-25-0009	20	FLAT WASHER 14 GA X 13/16"OD X 25/64" ID
18	NC02-32-0012	20	LOCK WASHER ZINC 3/8"
19	NC02-48-0021	12	FLAT HEAD SOCKET CAP SCREW 5/16-18 X 1"
20	NC13-45-0209	2	HYDRAULIC CYLINDER 6"

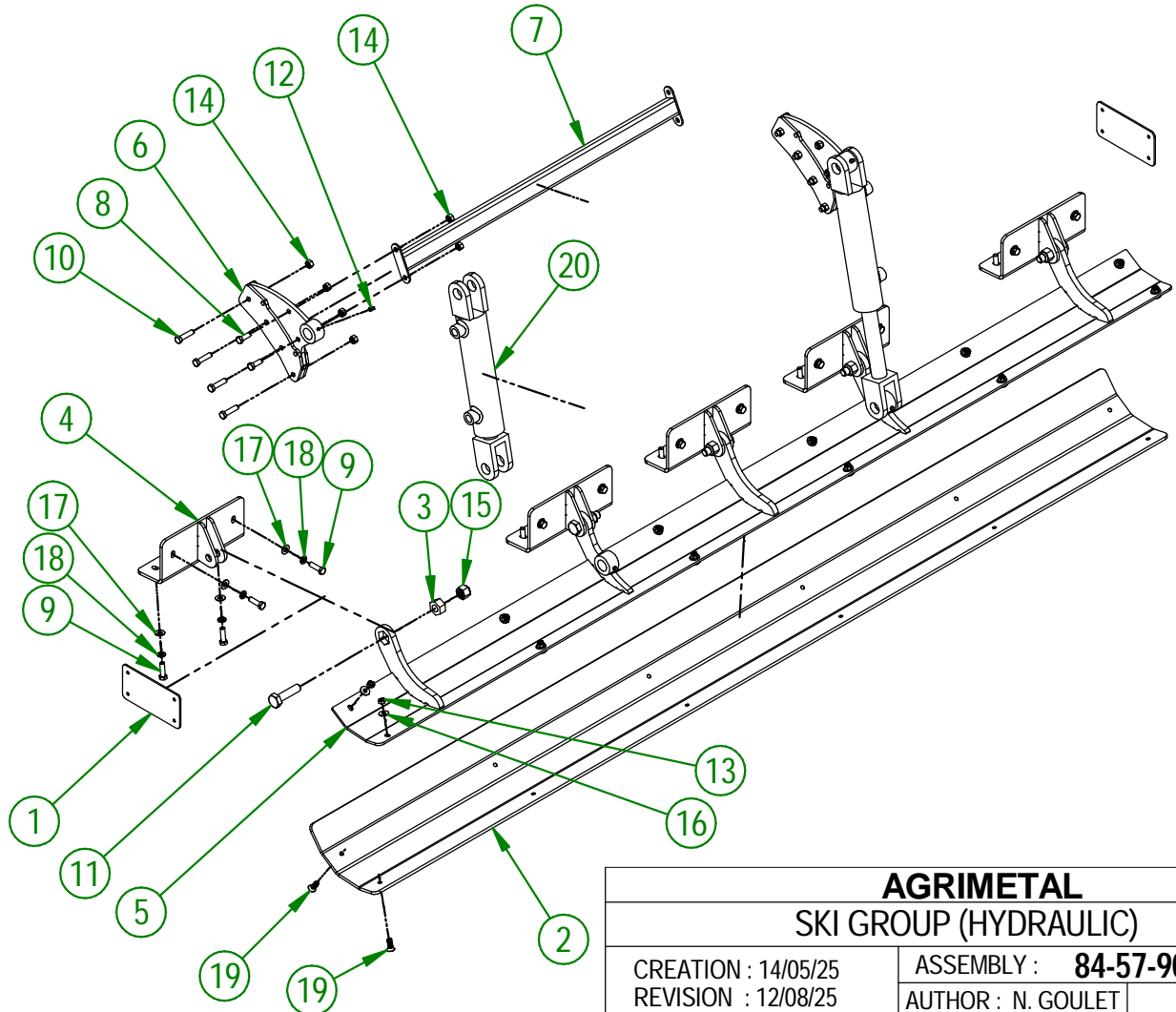

AGRIMETAL
SKI GROUP (HYDRAULIC)

CREATION : 14/05/25
REVISION : 12/08/25

ASSEMBLY : **84-57-9055**
AUTHOR : N. GOULET

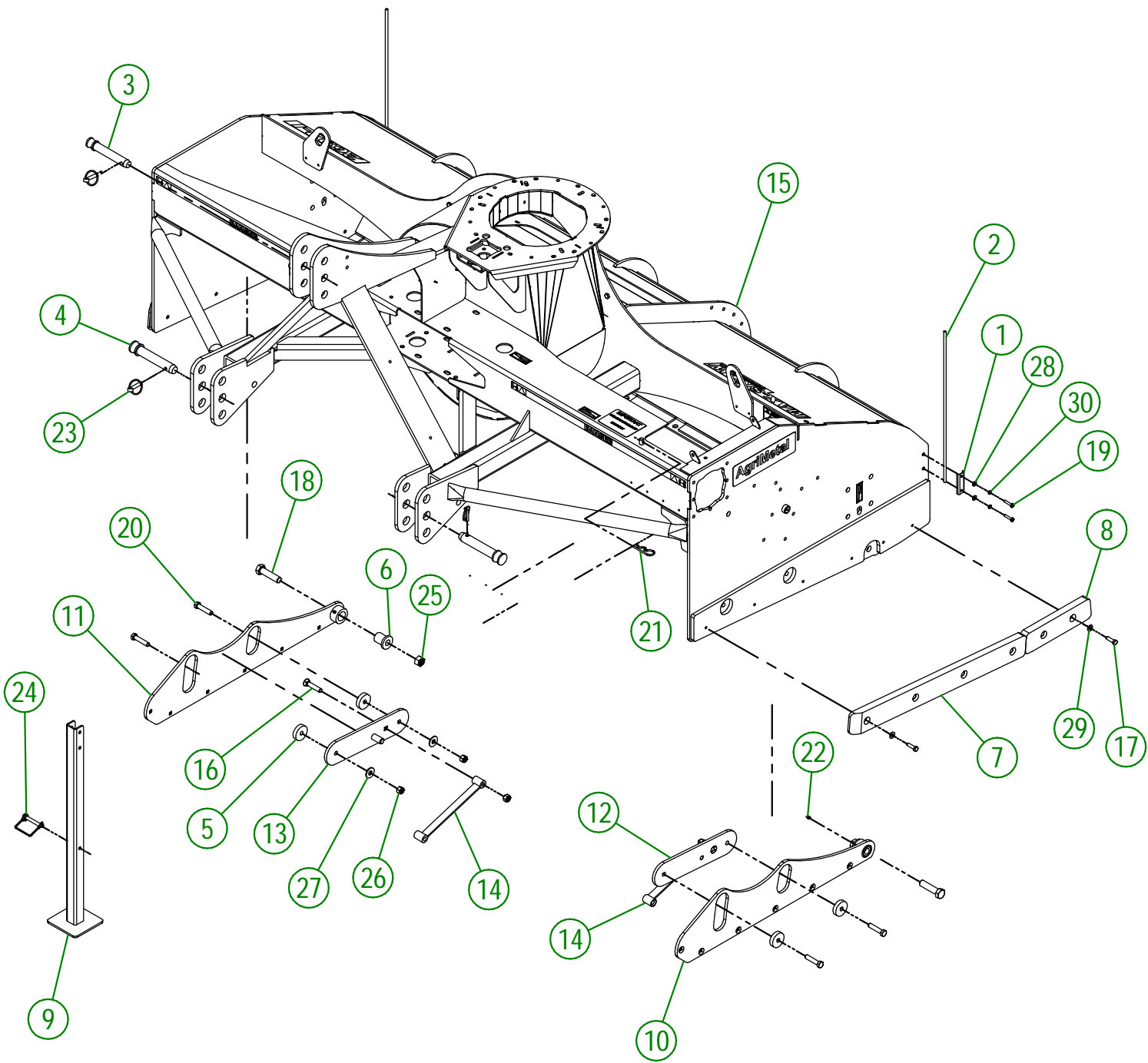

AGRIMETAL	
FRAME GROUP (MS2692-i)	
CREATION : 07/02/23	ASSEMBLY : 84-57-0140
REVISION : 22/12/25	AUTHOR : J. Houle

84-57-0140

#	PART #	Qty	TITLE
1	39-01-2440	2	GUIDE ROD CLAMP
2	39-42-0600	2	GUIDE ROD
3	48-20-0060	1	3 POINT PIN
4	48-20-0065	2	3 POINT PIN
5	84-13-2065	4	FLOATING SKATE BUSHING
6	84-13-2085	2	PIVOT BUSHING
7	84-42-0395	2	SIDE PROTECTION
8	84-42-0400	2	SIDE PROTECTION
9	84-50-0090	1	STAND
10	84-50-0210	1	LEFT FLOATING SKATE HOLDER
11	84-50-0215	1	RIGHT FLOATING SKATE HOLDER
12	84-50-0430	1	SPRING BLADE HOLDER (LEFT)
13	84-50-0435	1	SPRING BLADE HOLDER (RIGHT)
14	84-50-2005	2	SPRING BLADE
15	84-57-0124	1	FRAME
16	NC01-09-0034	2	PLOW BOLT GR5 1/2-13 X 2 1/2" LG
17	NC01-17-0115	12	HEX. BOLT GR2 ZINC 3/8-16 X 1 1/4"
18	NC01-25-0565	2	HEX. BOLT GR5 ZINC 3/4-10 X 3" LG.
19	NC01-29-0007	4	HEX. BOLT GR5 NF ZINC 1/4-28 X 1 1/4"
20	NC01-54-1252	4	HEX BOLT. GR2 STAINLESS 1/2-13 X 2 1/4"
21	NC01-63-0026	1	COTTER PIN ZC 5/32" X 3"
22	NC01-69-0785	3	STRAIGHT GREASE FITTING 1/4-28
23	NC01-69-1100	3	LINCH PIN 3/8"
24	NC01-69-1306	1	LOCKING PIN 3/8" X 2 1/2" LG
25	NC01-93-0017	2	HEX. LOCKNUT STEEL NC Z 3/4-10
26	NC01-96-0014	6	NYLON-INSERT LOCKNUT ZINC 1/2-13
27	NC02-22-0012	4	WASHER ZINC 1/2 BOLT = 9/16"Ø X 1 3/8" OD
28	NC02-25-0007	4	WASHER ZINC 0.281 = 9/32
29	NC02-26-1525	12	WASHER INOX .406" D.I. X .815" D.E.
30	NC02-32-0010	4	LOCK WASHER ZINC 1/4"

84-57-0138

#	PART #	Qty	TITLE
1	84-01-0014	1	IMPELLER ACCESS DOOR
2	84-55-0110	5	CLAMPING KNOB
3	84-57-0177	1	IMPELLER ACCESS DOOR
4	NC01-17-0114	2	HEX. BOLT GR2 ZINC 3/8-16 X 1"
5	NC01-64-0005	5	OVAL SLEEVE (ALUMINUM)
6	NC02-26-1525	2	WASHER INOX .406" D.I. X .815" D.E.
7	NC02-32-0012	2	LOCK WASHER ZINC 3/8"

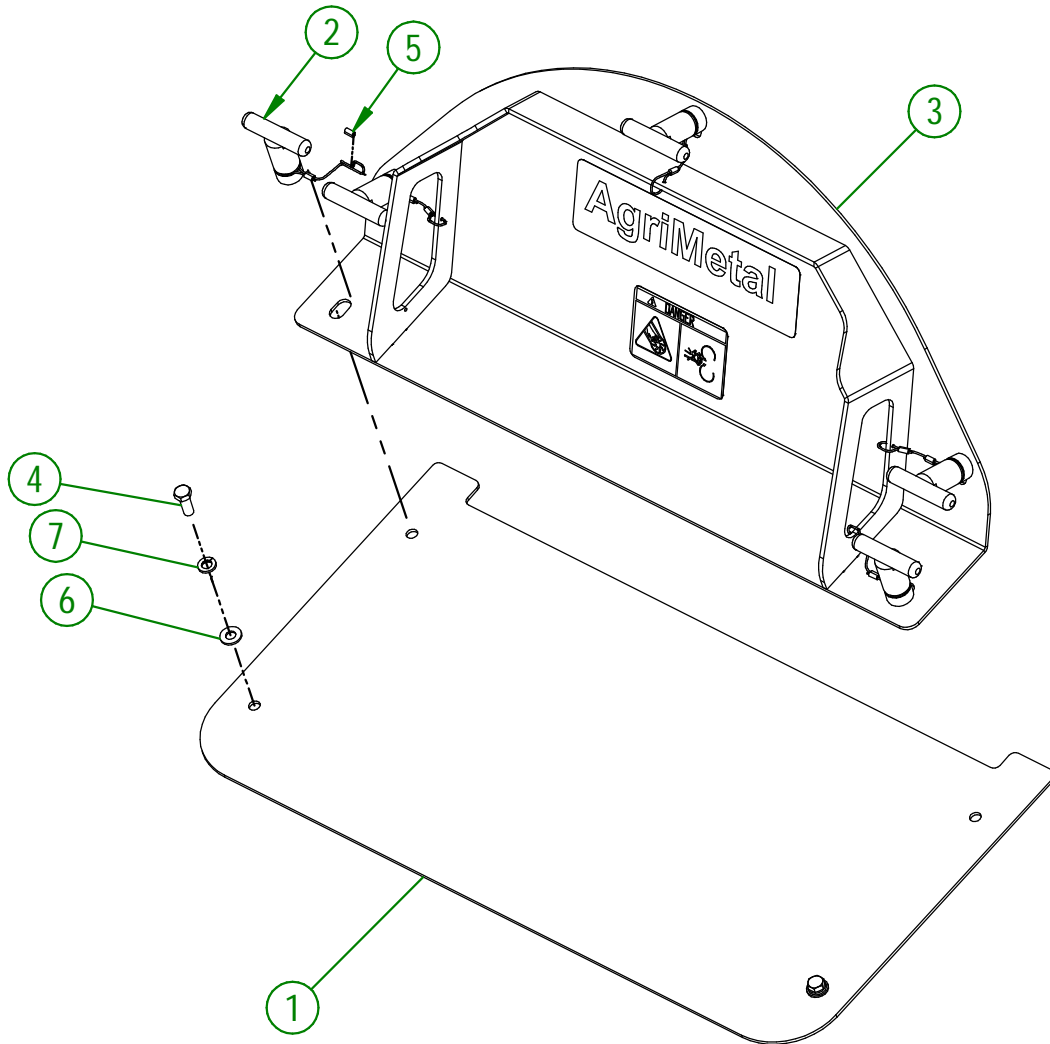

AGRIMETAL	
IMPELLER ACCESS DOOR GROUP	
CREATION : 20/04/23	ASSEMBLY : 84-57-0138
REVISION : 22/12/25	AUTHOR : J. Houle

80-57-0426

#	PART #	Qty	TITLE
1	80-50-0050	1	IMPELLER
2	NC01-94-0011	2	LOCK NUT 3/8-24
3	NC01-37-0121	2	HEX. BOLT GR8 ZINC 3/8-24 X 2 3/4" LG
4	NC02-32-0016	1	LOCK WASHER ZINC 5/8"
5	NC01-25-0395	1	HEX. BOLT GR5 ZINC 5/8-11 X 1 3/4" LG
6	80-04-0185	1	WASHER

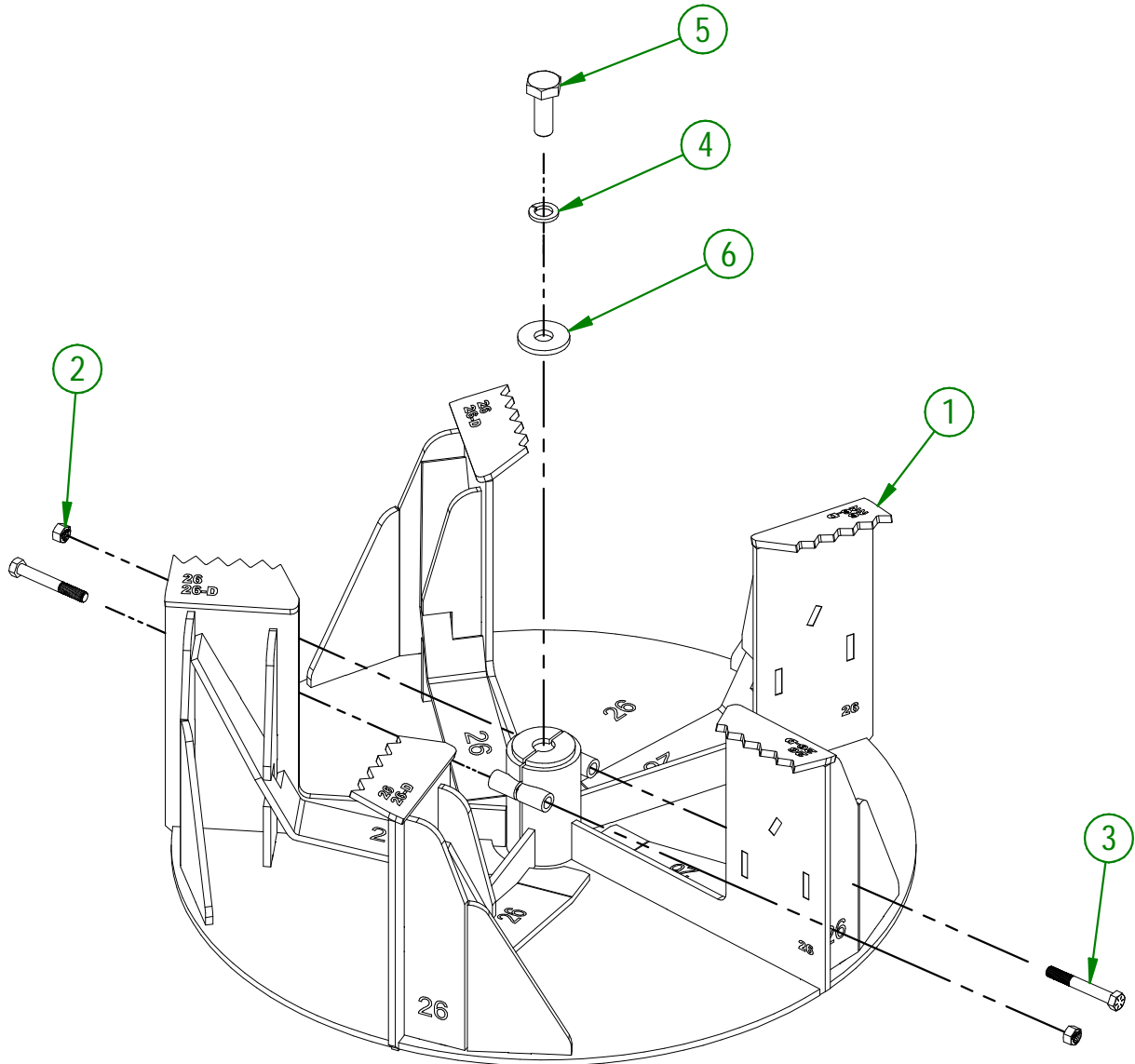

AGRIMETAL	
IMPELLER GROUP	
CREATION : 26/01/22	ASSEMBLY : 80-57-0426
REVISION : 30/03/22	AUTHOR : F.HÉLIE

84-57-0183

#	PART #	Qty	TITLE
1	NC14-75-0161	2	FLANGE BEARING UCF 208-24 1 1/2" ID
2	84-50-0173	1	SPIRAL
3	81-01-1511	1	ALIGNMENT SHIM
4	NC02-32-0016	8	LOCK WASHER ZINC 5/8"
5	NC02-07-0022	8	HEX. NUT ZINC 5/8-11
6	NC02-25-0013	8	WASHER ZINC SAE ZINC 21/32 ID
7	NC01-17-0396	8	HEX. BOLT GR2 ZINC 5/8-11 X 2"
8	NC14-55-0275	1	80A34 SPROCKET
9	NC01-29-0249	4	HEX. BOLT GR5 ZINC 1/2-20 X 1 1/2
10	NC01-94-0013	4	JAM NUT 1/2-20
11	102-51-1070	1	SHAFT OF THE SPIRAL
12	84-51-0360	1	SHAFT OF THE SPIRAL (SPROCKET)

REBUILD KIT

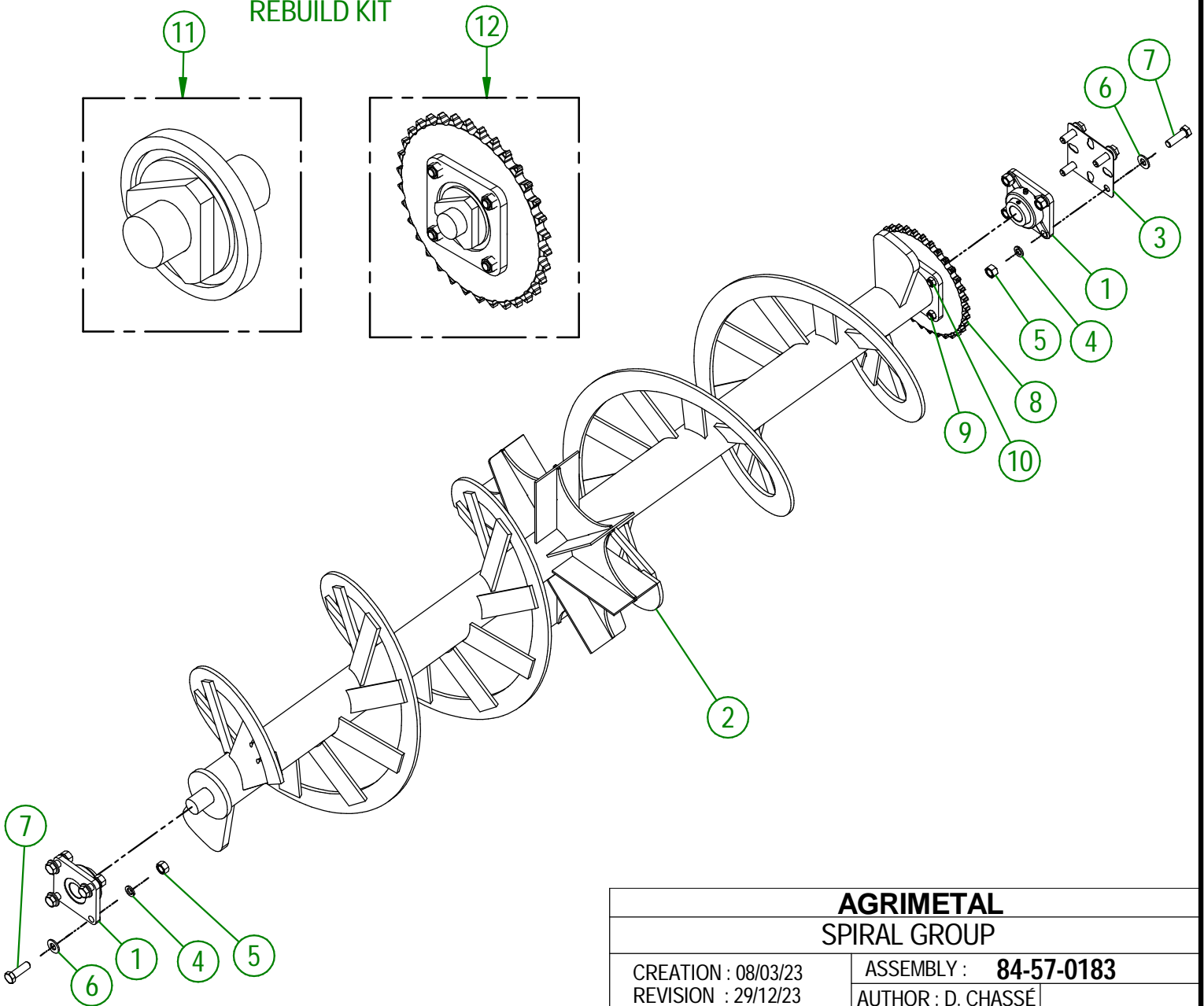

AGRIMETAL
SPIRAL GROUP

CREATION : 08/03/23
REVISION : 29/12/23

ASSEMBLY : **84-57-0183**
AUTHOR : D. CHASSÉ

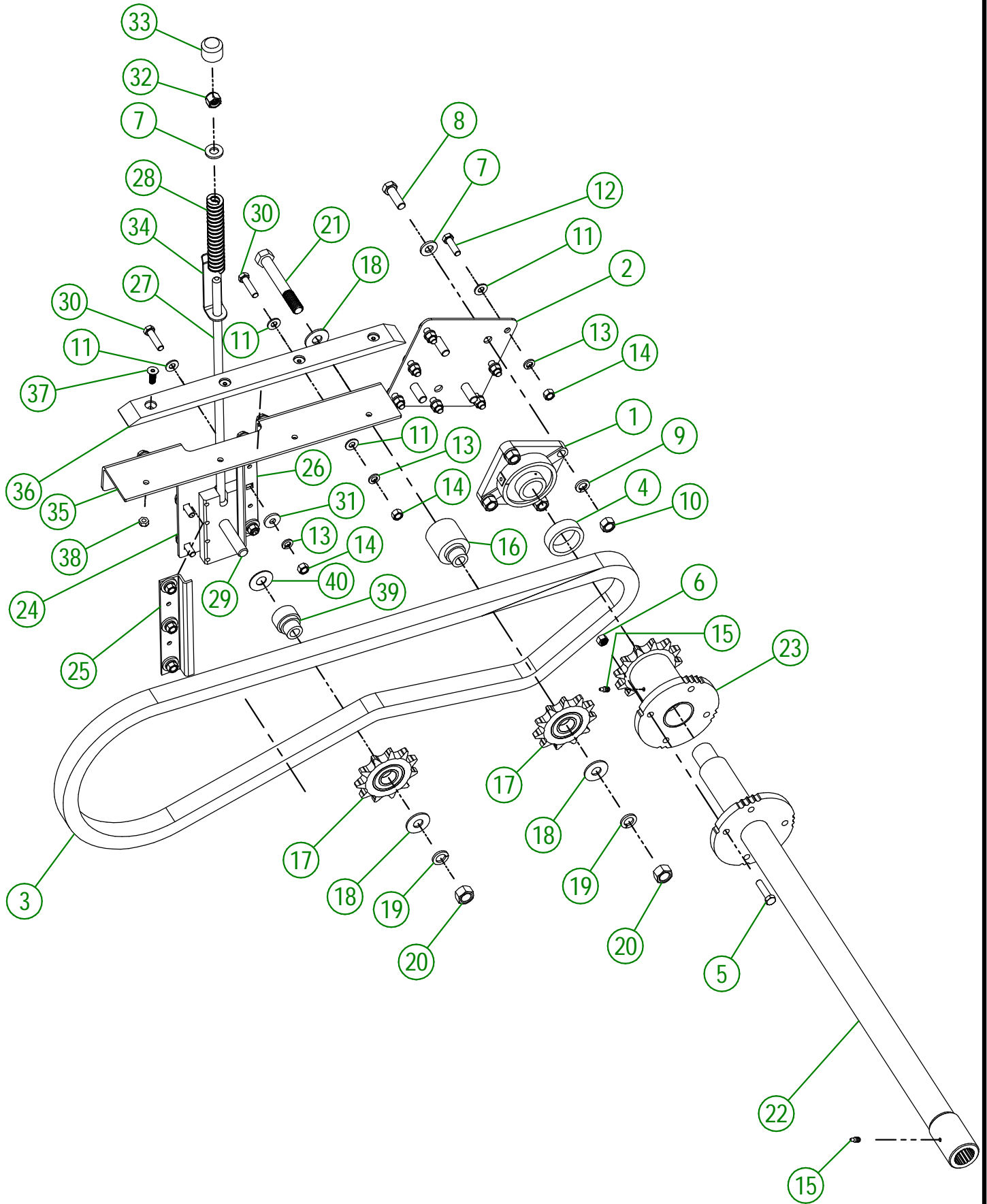

AGRIMETAL	
REGROUPEMENT ENTRAÎNEMENT DE SPIRALE	
CREATION : 07/02/23	ASSEMBLY : 84-57-0133
REVISION : 22/12/25	AUTHOR : D. CHASSÉ

84-57-0133

#	PART #	Qty	TITLE
1	NC14-75-0024	1	FLANGE BEARING 4 HOLES UCF207-20 I 1/4" DIA.
2	84-01-0905	1	COUNTER SHAFT BEARING SUPPORT
3	84-37-1007	1	CHAIN #80
4	84-24-0005	1	SPIRAL DRIVE TRAIN BUSHING
5	NC01-25-0116	1	HEX. BOLT GR5 ZINC 3/8-16 X I 1/2"
6	NC01-93-0011	1	LOCK NUT 3/8-16
7	NC02-25-0011	5	WASHER SAE ZINC 17/32 ID
8	NC01-17-0249	4	HEX. BOLT GR2 ZINC 1/2-13 X I 1/2"
9	NC02-32-0014	4	LOCK WASHER ZINC 1/2"
10	NC02-07-0020	4	HEX. NUT ZINC 1/2-13
11	NC02-26-1525	19	WASHER INOX .406" D.I. X .815" D.E.
12	NC01-17-0115	7	HEX. BOLT GR2 ZINC 3/8-16 X I 1/4"
13	NC02-32-0012	16	LOCK WASHER ZINC 3/8"
14	NC02-07-0018	16	HEX. NUT ZINC 3/8-16
15	NC01-69-0785	2	STRAIGHT GREASE FITTING 1/4-28
16	81-21-0002	1	CHAIN TENSIONER BUSHING
17	81-55-0005	2	CHAIN TENSIONER SPROCKET
18	NC02-22-0013	3	WASHER ZINC 5/8 ID X I 1/2 OD
19	NC02-32-0016	2	LOCK WASHER ZINC 5/8"
20	NC02-10-0022	2	HEX. NUT ZINC 5/8-18
21	NC01-17-0406	1	HEX. BOLT GR2 ZINC 5/8-11 X 4 1/2"
22	84-50-0166	1	SPIRAL DRIVE TRAIN
23	NC14-55-0328	1	SPROCKET
24	102-04-0180	1	CHAIN TENSIONER HOLD DOWN PLATE
25	81-01-0927	1	SUPPORT FOR CHAIN TENSIONER
26	81-01-0928	1	SUPPORT FOR CHAIN TENSIONER
27	84-50-0321	1	SUPPORT FOR CHAIN TENSIONER
28	NC13-86-0054	1	BLUE SPRING 1/2" ID X 1" OD X 6" LG
29	NC01-29-0400	1	HEX. BOLT GR5 ZINC 5/8-18 X 3"
30	NC01-17-0116	9	HEX. BOLT GR2 ZINC 3/8-16 X I 1/2"
31	21-01-0950	6	FLAT WASHER 10GA 1.005" DIA X 25/64"
32	NC01-96-0014	1	NYLON-INSERT LOCKNUT ZINC 1/2-13
33	80-42-0110	1	THREADED ROD CAP
34	83-57-0160	1	ADJUSTMENT INDICATOR
35	84-04-0576	1	SLIDING CHAIN STRIP SUPPORT
36	102-42-0010	1	SLIDING CHAIN STRIP
37	NC02-48-0021	4	FLAT HEAD SOCKET CAP SCREW 5/16-18 X 1"
38	NC01-93-0010	4	LOCK NUT ZINC 5/16-18
39	102-21-0015	1	CHAIN TENSIONER BUSHING
40	84-01-0200	1	CHAIN TENSIONER BUSHING SPACER

84-57-0161

#	PART #	Qty	TITLE
1	NC02-26-1525	4	WASHER INOX .406" D.I. X .815" D.E.
2	NC01-17-0114	2	HEX. BOLT GR2 ZINC 3/8-16 X 1"
3	NC01-96-0011	2	NYLON NUT 3/8-16
4	84-57-0156	1	CHAIN GUARD

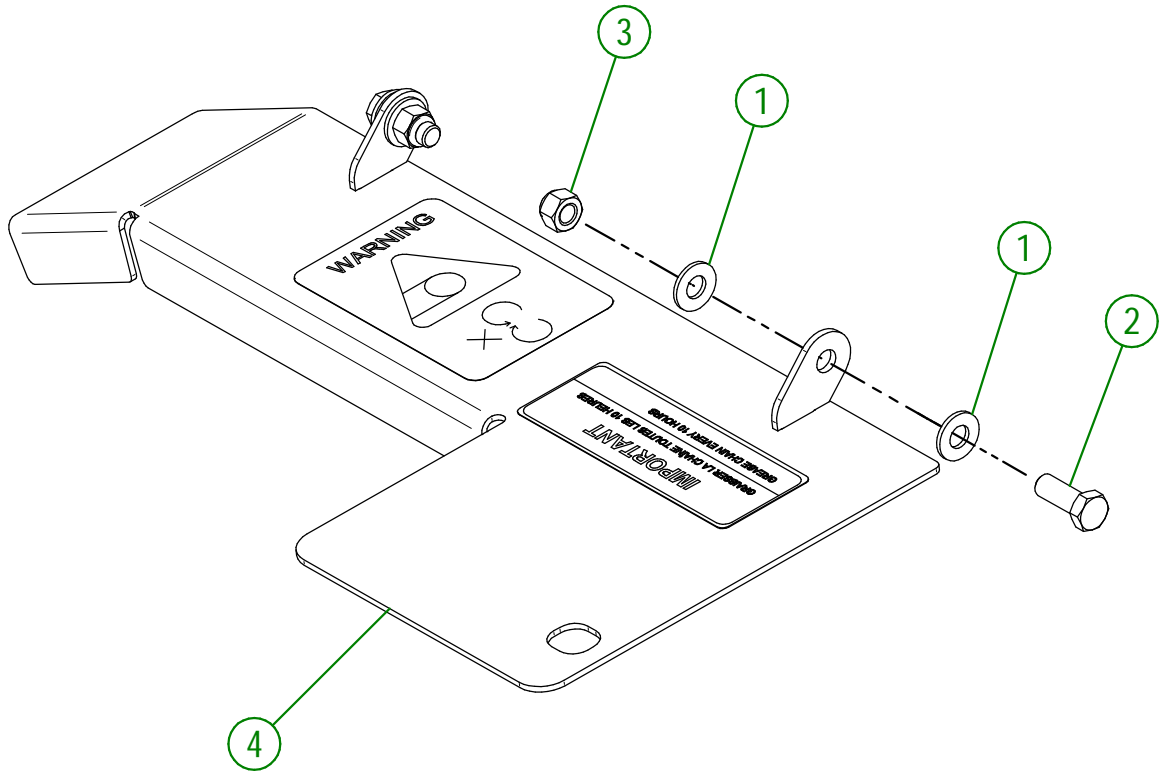

AGRIMETAL	
CHAIN GUARD GROUP	
CREATION : 30/03/22	ASSEMBLY : 84-57-0161
REVISION : 22/12/25	AUTHOR : J. Houle

#	PART #	Qty	TITLE
1	84-55-0010	1	GEARBOX
2	NC02-25-0011	14	WASHER SAE ZINC 17/32 ID
3	NC02-32-0014	12	LOCK WASHER ZINC 1/2"
4	NC01-33-0248	8	HEX. BOLT .GR8 NC ZINC 1/2-13 X 1 1/4"
5	80-41-0135	1	PTO GUARD STEEL CABLE
6	NC01-64-0005	2	OVAL SLEEVE (ALUMINUM)
7	80-41-0900	1	IMPELLER KEY
8	NC13-25-0019	1	BLACK TIE RAP
9	NC13-50-0110	1	IMPORTANT/NOTICE PTO POSTER
10	81-57-0040	1	PTO GUARD
11	80-34-0030	1	PTO SHAFT T60
12	84-01-0095	1	PTO GUARD SUPPORT
13	80-04-0485	1	GEARBOX BRACE
14	80-04-0480	1	GEARBOX BRACE
15	NC01-33-0249	4	CAP SCREW GR8 NC ZINC 1/2-13 X 1 1/2" LG
16	NC02-07-0020	4	HEX. NUT ZINC 1/2-13
17	NC01-63-0027	1	HAIRPIN COTTER
18	84-04-0660	2	GEARBOX SPACER

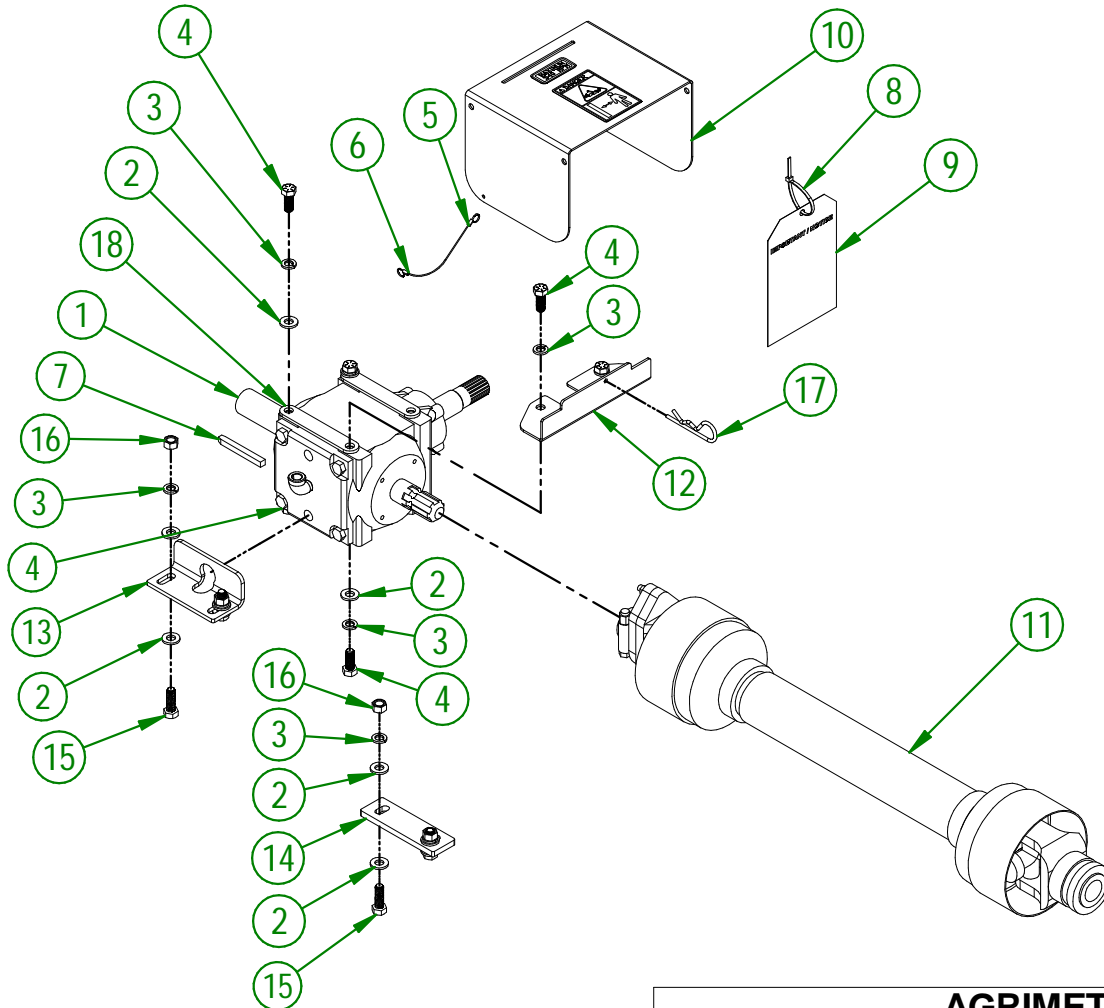

AGRIMETAL
GEARBOX GROUPING

CREATION : 06/12/17
REVISION : 25/05/22

ASSEMBLY : **84-57-0100**
AUTHOR : F.HÉLIE

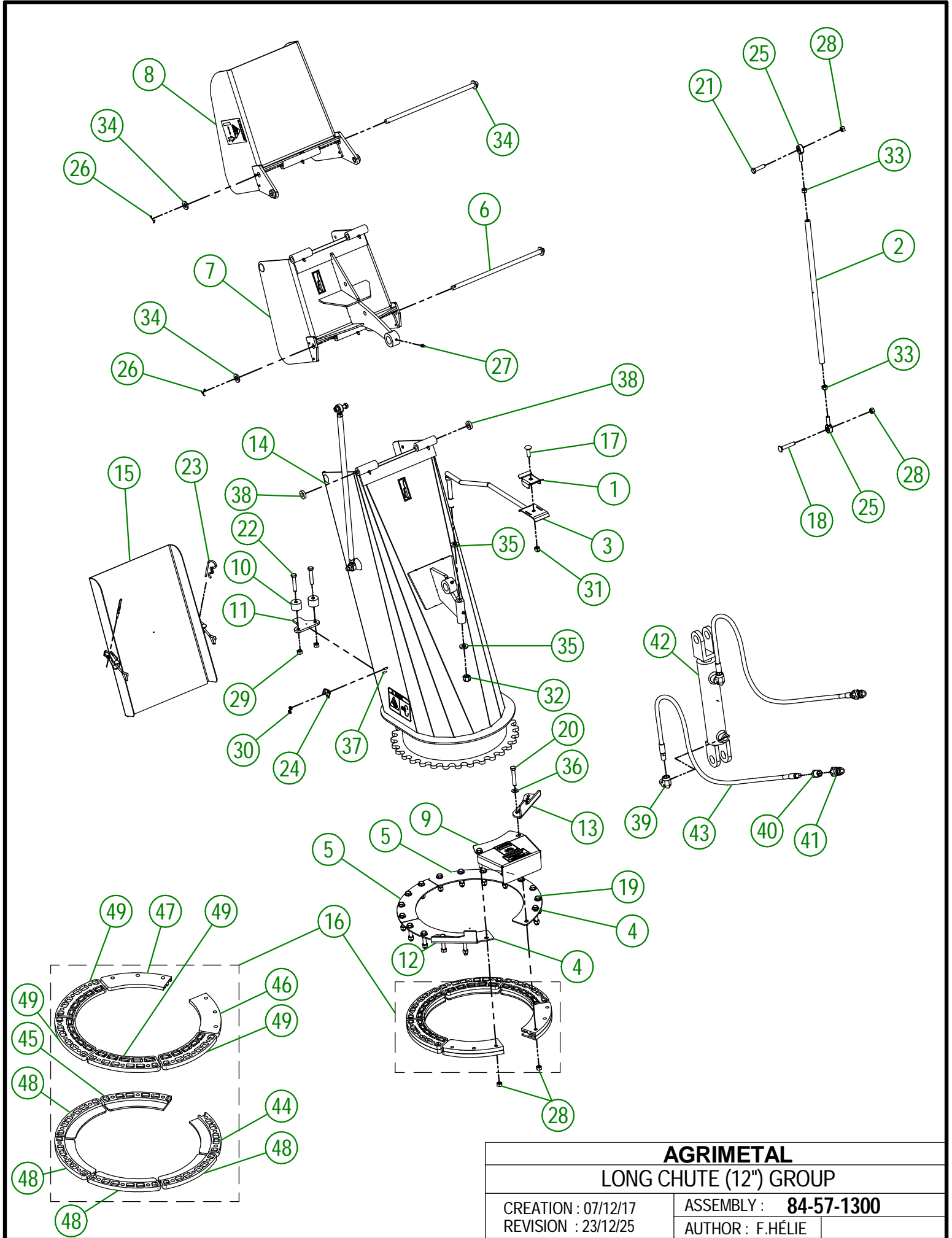

AGRIMETAL

LONG CHUTE (12") GROUP

CREATION : 07/12/17
 REVISION : 23/12/25

ASSEMBLY : **84-57-1300**
 AUTHOR : F.HÉLIE

84-57-1300

#	PART #	Qty	TITLE
1	48-01-7530	1	HYDRAULIC HOSE SUPPORT
2	48-13-0600	2	CHUTE ROD (DOUBLE)
3	48-50-1030	1	HYDRAULIC HOSE SUPPORT
4	80-01-1010	2	BRACE
5	80-01-1015	2	BRACE
6	80-20-0260	2	PIVOT
7	80-57-0312	1	CHUTE (MIDDLE SECTION)
8	80-57-0322	1	CHUTE (TOP SECTION)
9	80-57-0550	1	SPROCKET GUARD GROUP "STICKER INCLUDED"
10	81-21-0040	2	ADJUSTABLE STOPPER SPACER
11	84-04-0170	1	STOPPER
12	84-04-0175	1	ADJUSTABLE STOPPER
13	84-04-0177	1	ADJUSTABLE STOPPER
14	84-57-1305	1	CHUTE (BOTTOM SECTION)
15	84-57-1310	1	CHUTE DOOR
16	84-57-1330	1	GUIDE CHUTE GROUP
17	NC01-04-0110	1	CARR. BOLT GR2 ZINC 3/8-16 X 1 1/4"
18	NC01-07-0113	2	CARR. BOLT GR5 ZINC 3/8-16 X 2" LG
19	NC01-17-0118	14	HEX. BOLT GR2 ZINC 3/8-16 X 2"
20	NC01-17-0119	4	HEX. BOLT GR2 ZINC 3/8-16 X 2 1/4"
21	NC01-25-0116	2	HEX. BOLT GR5 ZINC 3/8-16 X 1 1/2"
22	NC01-37-0118	2	HEX. BOLT GR8 ZINC 3/8-24 X 2"
23	NC01-63-0026	2	COTTER PIN ZC 5/32" X 3"
24	NC01-63-0052	2	ADJUSTABLE LATCH (STRIKE)
25	NC01-67-0304	4	ROD END 3/8-24
26	NC01-69-0139	4	COTTER PIN ZINC 1/8" X 3/4"
27	NC01-69-0785	9	STRAIGHT GREASE FITTING 1/4-28
28	NC01-93-0011	22	LOCK NUT 3/8-16
29	NC01-94-0011	2	LOCK NUT 3/8-24
30	NC01-96-0006	4	NYLON NUT ZINC 3/16
31	NC01-96-0011	1	NYLON NUT 3/8-16
32	NC01-96-0014	1	NYLON-INSERT LOCKNUT ZINC 1/2-13
33	NC02-10-0018	4	NUT 3/8-24
34	NC02-25-0011	4	WASHER SAE ZINC 17/32 ID
35	NC02-25-0011	2	WASHER SAE ZINC 17/32 ID
36	NC02-26-1525	18	WASHER INOX .406" D.I. X .815" D.E.
37	NC02-40-0080	4	MACHINE SCREWS SQUARE SOCKET #10-24 X 1/2" LG
38	NC13-15-0334	2	PIVOT WASHER
39	NC13-45-0038	2	ELBOW 90 3/8 FEM. NPT X 3/8 MALE NPT
40	NC13-45-0153	2	HEX. REDUCER 1/4 NPT X 1/2 NPT
41	NC13-45-0369	2	QUICK COUPLER 1/2-14 NPTF
42	NC13-45-0404	1	HYDRAULIC CYLINDER 6"
43	NC17-02-0329	2	HYDRAULIC HOSE (87" LG)

84-57-1330

#	PART #	Qty	TITLE
44	80-42-0305	1	CHUTE GUIDE (UNDER)
45	80-42-0310	1	CHUTE GUIDE (UNDER)
46	80-42-0315	1	CHUTE GUIDE (TOP)
47	80-42-0320	1	CHUTE GUIDE (TOP)
48	NC17-46-0027	4	CHUTE GUIDE (UNDER)
49	NC17-46-0028	4	CHUTE GUIDE (TOP)

#	PART #	Qty	TITLE
1	48-01-7527	1	HYDRAULIC HOSE SUPPORT
2	48-50-1025	1	HYDRAULIC ENGINE SPROCKET
3	80-13-0100	2	HYDRAULIC RESTRICTOR
4	80-45-0000	2	HEX. REDUCER 1/4 NPT X 1/2 NPT
5	81-01-7600	1	HYDRAULIC HOSE SUPPORT
6	NC01-07-0111	1	CARR. BOLT GR5 ZINC 3/8-16 X 1 1/2"
7	NC01-17-0115	2	HEX. BOLT GR2 ZINC 3/8-16 X 1 1/4"
8	NC01-33-0113	4	HEX.BOLT GR8 ZINC 3/8-16 X 3/4"
9	NC01-45-0184	1	HEX. BOLT GR8.8 ZINC 8MM X 20MM
10	NC01-96-0011	1	NYLON NUT 3/8-16
11	NC02-07-0018	2	HEX. NUT ZINC 3/8-16
12	NC02-26-0504	1	WASHER
13	NC02-26-1525	2	WASHER INOX .406" D.I. X .815" D.E.
14	NC02-32-0011	1	LOCK WASHER ZINC 5/16"
15	NC02-32-0012	6	LOCK WASHER ZINC 3/8"
16	NC02-44-0103	2	SET SCREW 5/16-18 X 3/8"
17	NC13-45-0367	2	45°-7/8-14 MALE O RING X 1/2 FEM.TOUR.NPT PT
18	NC13-45-0369	2	QUICK COUPLER 1/2-14 NPTF
19	NC13-45-0378	2	HYDRAULIC RESTRICTOR BUSHING
20	NC14-45-0156	1	HYDRAULIC MOTOR
21	NC17-02-0328	2	HYDRAULIC HOSE (63" LG)
22	NC17-46-0031	1	HYDRAULIC MOTOR BUSHING

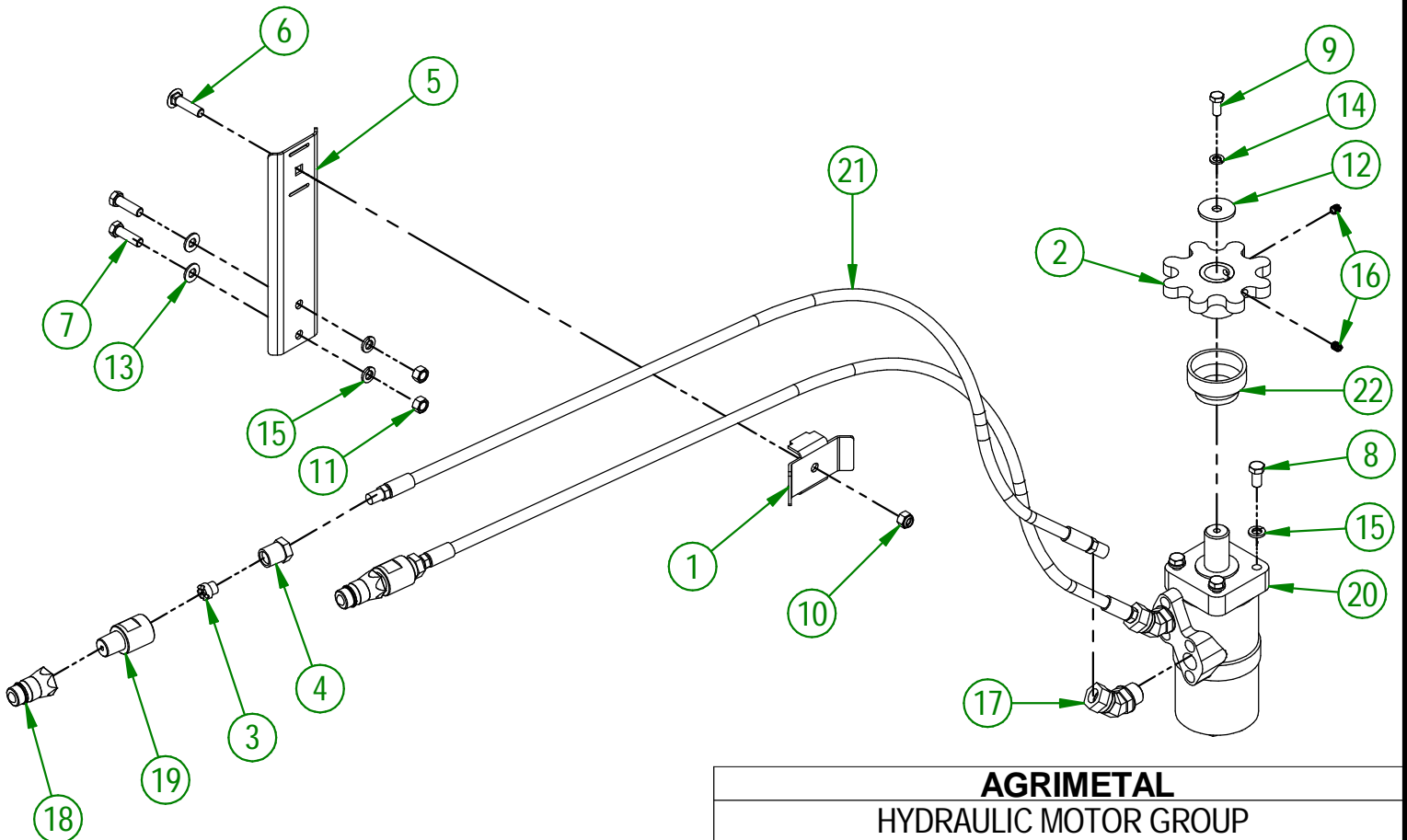

AGRIMETAL
HYDRAULIC MOTOR GROUP

CREATION : 05/08/19
 REVISION : 25/03/26

ASSEMBLY : **84-57-0410**
 AUTHOR : F.HÉLIE

#	PART #	Qty	TITLE
1	NC13-30-0237	1	PLASTIC TUBE FOR OPERATOR'S MANUAL
2	NC02-22-0008	2	WASHER ZINC 5/16"
3	NC01-17-0007	2	HEX. BOLT GR2 ZINC 1/4-20 X 1 1/4"
4	NC01-96-0009	2	NYLON-INSERT LOCKNUT ZINC 1/4-20
5	81-57-0030	1	SET OF 6 SHEAR BOLT WITH NUT
6	84-98-0520	1	ENGLISH OPERATOR'S MANUAL (MS2692-i, MS2482-i)

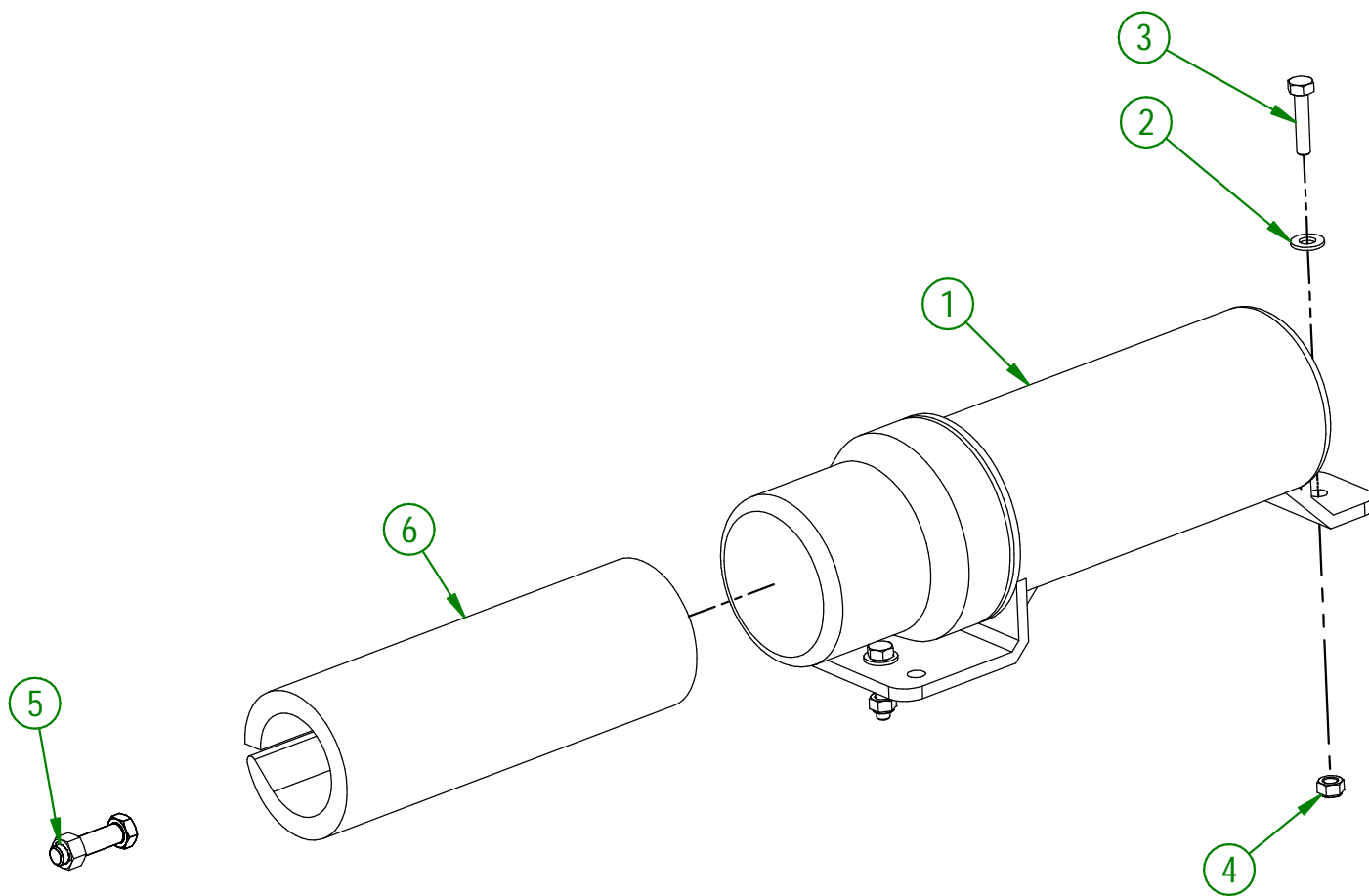

AGRIMETAL	
OPERATOR'S MANUAL TUBE GROUP	
CREATION : 03/01/18	ASSEMBLY : 84-57-1320
REVISION : 31/03/22	AUTHOR : F.HÉLIE

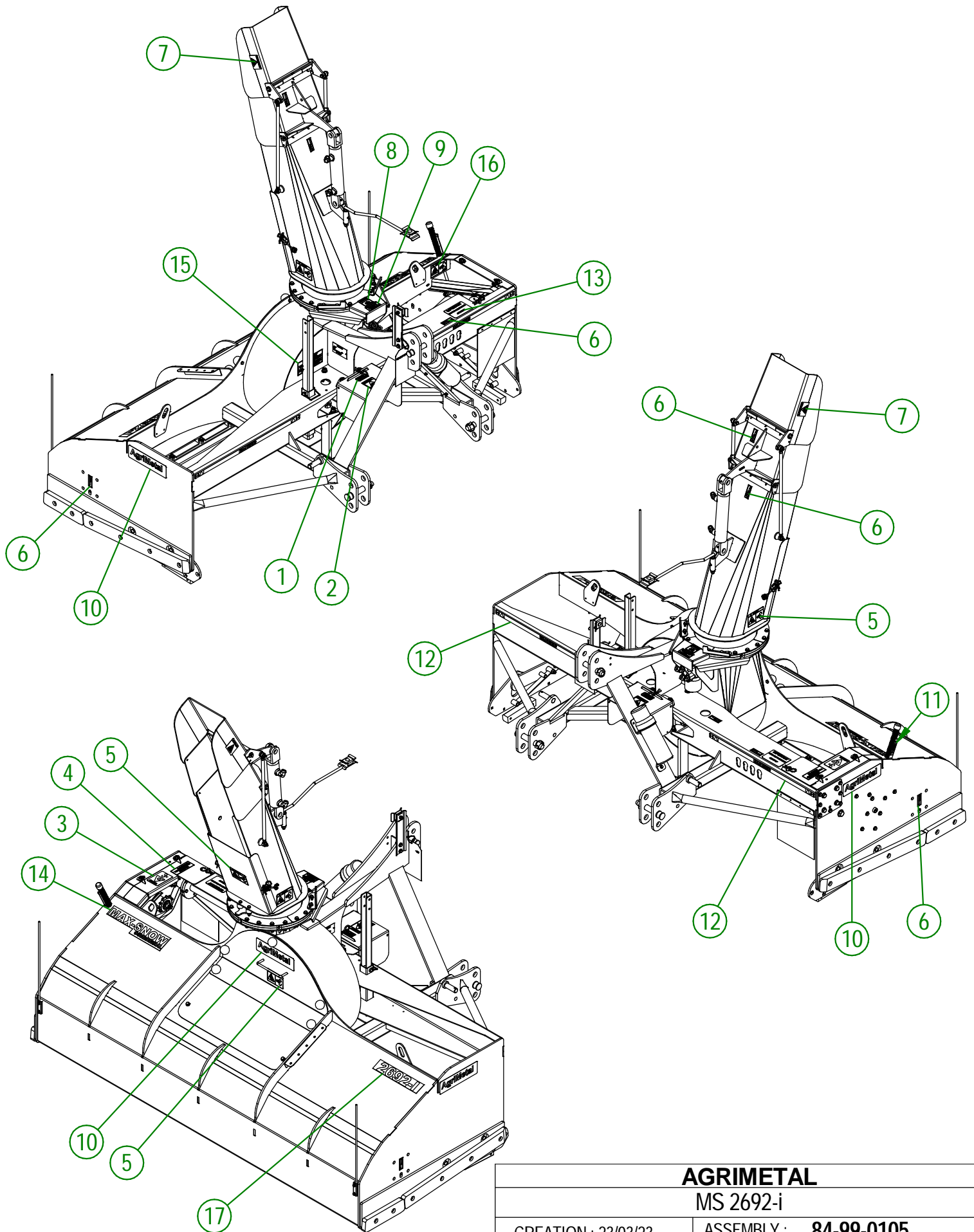

AGRIMETAL

MS 2692-i

CREATION : 23/03/23
 REVISION : 23/03/23

ASSEMBLY : **84-99-0105**
 AUTHOR : J. Houle

84-99-0105

#	PART #	Qty	TITLE
1	NC13-33-0005	1	STICKER MAXIMUM 540 RPM
2	NC13-33-0187	1	STICKER DANGER (PTO AND PERSON)
3	NC13-33-0283	1	STICKER DANGER (PERSON AND CHAIN DRIVE)
4	NC13-33-0343	1	GREASE CHAIN EVERY 10 HOURS STICKER
5	NC13-33-0249	4	STICKER DANGER
6	NC13-33-0024	6	STICKER GREASE HERE
7	NC13-33-0192	2	STICKER (PROJECTION RISK)
8	NC13-33-0326	1	STICKER DANGER (HAND)
9	NC13-33-0327	1	STICKER END ROTATION ADJUSTMENT
10	NC13-33-0035	3	STICKER AGRIMETAL
11	NC13-33-0344	1	ADJUSTMENT INDICATOR STICKER
12	NC13-33-0274	2	STICKER DANGER
13	NC13-33-0281	1	STICKER SHEAR BOLT
14	NC13-33-0241	1	STICKER MAX-SNOW COMMERCIAL
15	NC13-33-0317	1	STICKER GREASE DRIVE LINE TELESCOPIC SHAFT
16	NC13-33-0247	1	STICKER DANGER
17	NC13-33-0316	1	STICKER 2692-i