

AgriMetal

PART LIST

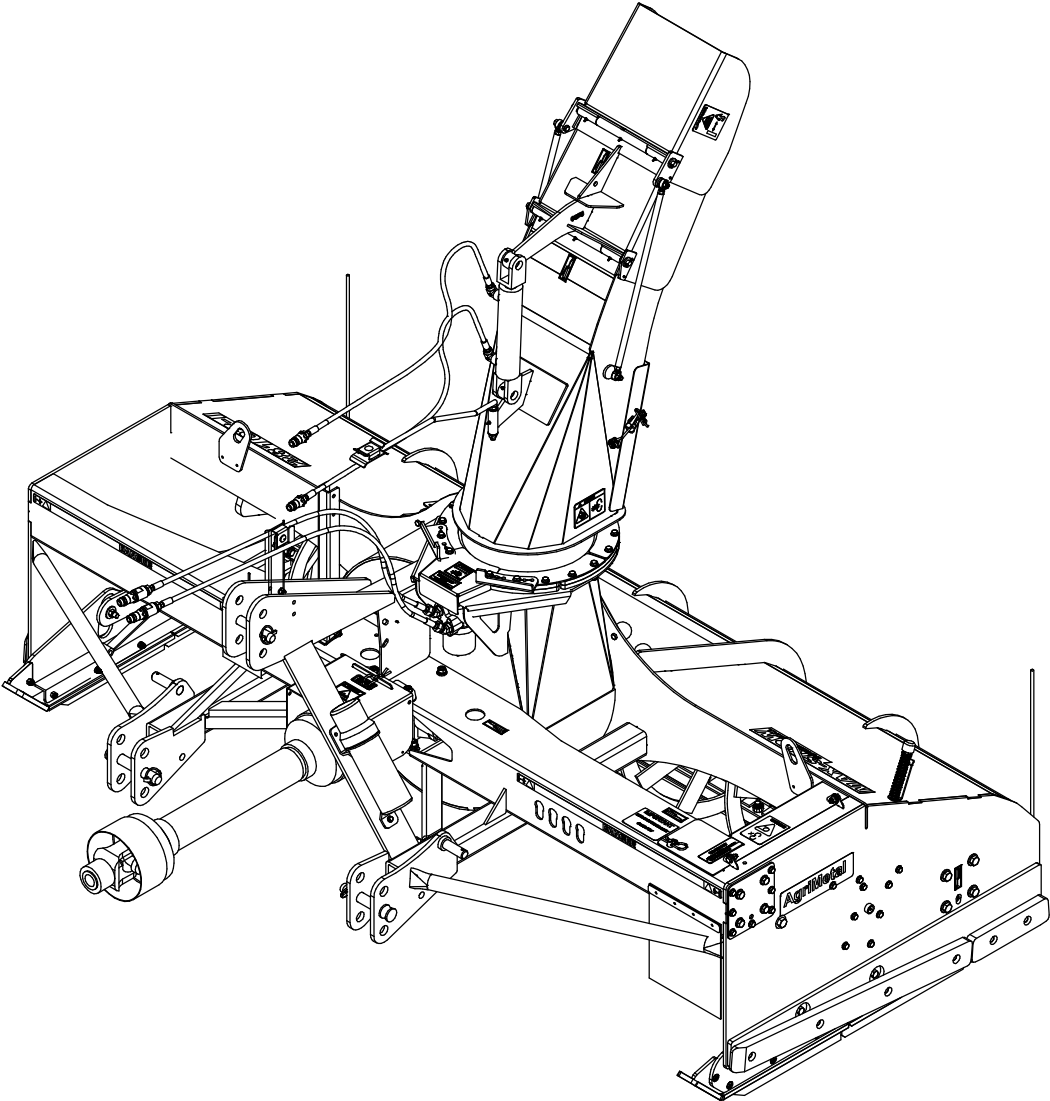

MS 28102-I

84-57-0327

#	PART #	Qty	TITLE
1	84-20-0450	2	KNIFE (#450 HARDNESS STEEL)
2	NC01-09-0039	14	PLOW BOLT GR5 5/8-11 X 1 1/2" LG
3	NC01-93-0016	14	LOCK NUT ZINC 5/8-11
4	84-42-0340	2	WEAR STRIP FOR SPRING BLADE
5	NC01-96-0011	14	NYLON NUT 3/8-16
6	NC01-09-0011	10	SQUARE-NECK FLAT HEAD PLOW BOLT 3/8-16 X 1 1/4"
7	NC02-48-0539	4	STAINLESS FLAT HEAD SOCKET CAP SREW 3/8-16 X 2 3/4"
8	84-50-0350	1	BACK RIGHT FLOATING SKATE (QT-450)
9	84-50-0355	1	BACK LEFT FLOATING SKATE (QT-450)
10	84-50-0360	1	FRONT LEFT FLOATING SKATE (QT-450)
11	84-50-0365	1	FRONT RIGHT FLOATING SKATE (QT-450)

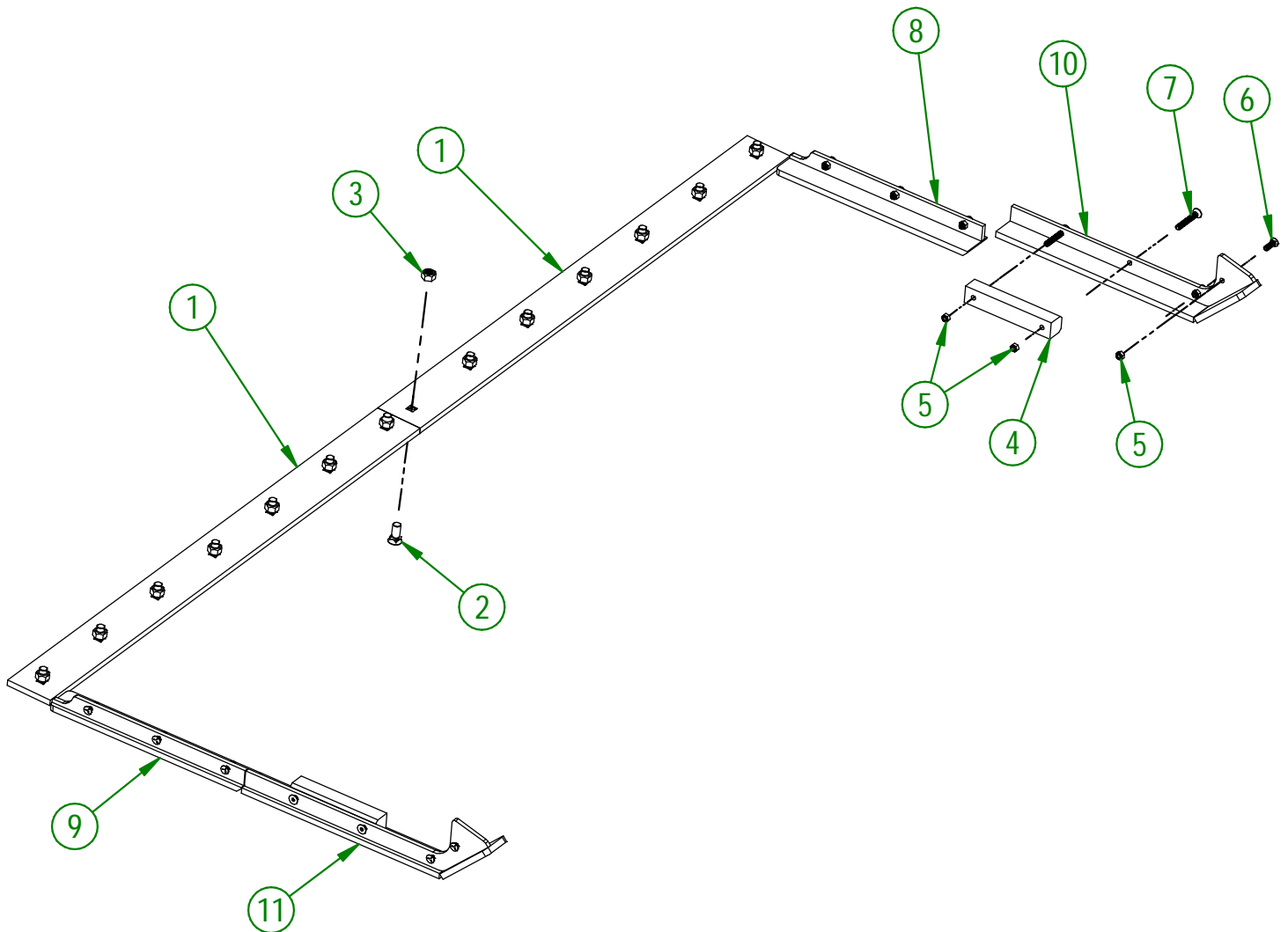

AGRIMETAL	
SET OF KNIVES (QT-450)	
CREATION : 06/03/23	ASSEMBLY : 84-57-0327
REVISION : 30/03/23	AUTHOR : D. CHASSÉ

84-57-0332

#	PART #	Qty	TITLE
1	84-50-0450	2	KNIFE BRACE (TOP)
2	84-42-0505	1	LEFT KNIFE (UHMW)
3	84-04-0815	2	KNIFE BRACE (UNDER)
4	NC01-96-0011	12	NYLON NUT 3/8-16
5	NC02-48-0564	14	FLAT HEAD SOCKET CAP SCREW STAINLESS 5/8-11 X 2" LG
6	NC01-93-0016	14	LOCK NUT ZINC 5/8-11
7	84-42-0510	1	RIGHT KNIFE (UHMW)
8	84-42-0525	2	FLOATING SKATE (UHMW)
9	84-16-0000	2	FLOATING SKATE BRACE
10	NC01-09-0016	12	SQUARE-NECK FLAT HEAD PLOW BOLT 3/8-16 X 2 1/2 LG

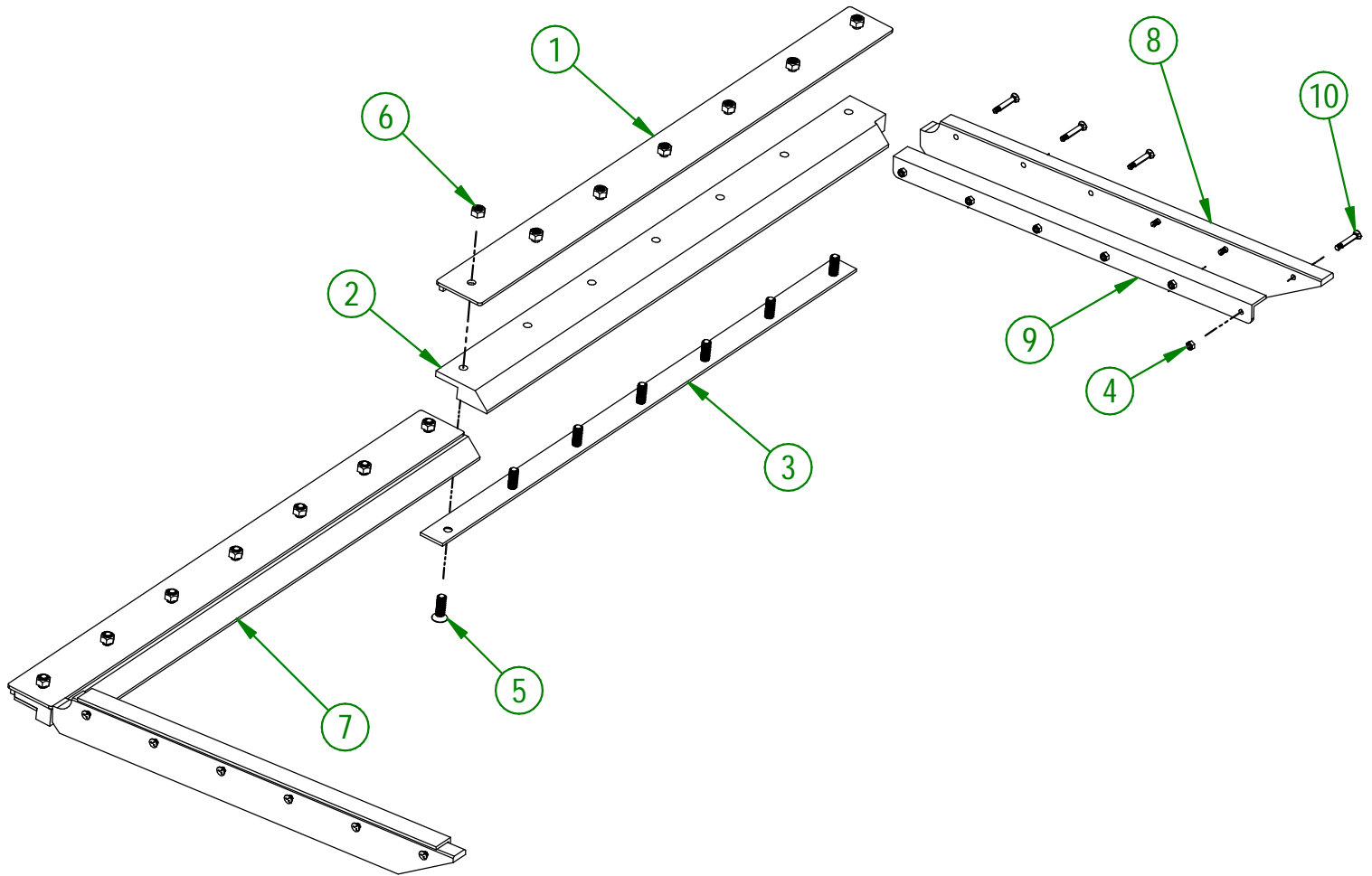

AGRIMETAL	
SET OF KNIVES (UHMW)	
CREATION : 06/03/23	ASSEMBLY : 84-57-0332
REVISION : 28/04/25	AUTHOR : D. CHASSÉ

84-57-0337

#	PART #	Qty	TITLE
1	84-20-0455	2	KNIFE (STAINLESS STEEL)
2	NC02-48-0562	14	FLAT HEAD SOCKET CAP SCREW STAINLESS 5/8-11 X 1 1/2"
3	NC01-93-0016	14	LOCK NUT ZINC 5/8-11
4	84-42-0340	2	WEAR STRIP FOR SPRING BLADE
5	NC02-48-0539	4	STAINLESS FLAT HEAD SOCKET CAP SREW 3/8-16 X 2 3/4"
6	NC01-96-0011	14	NYLON NUT 3/8-16
7	NC01-09-0011	10	SQUARE-NECK FLAT HEAD PLOW BOLT 3/8-16 X 1 1/4"
8	84-50-0330	1	FRONT RIGHT FLOATING SKATE
9	84-50-0340	1	BACK RIGHT FLOATING SKATE (STAINLESS)
10	84-50-0335	1	FRONT LEFT FLOATING SKATE (STAINLESS)
11	84-50-0345	1	BACK LEFT FLOATING SKATE (STAINLESS)

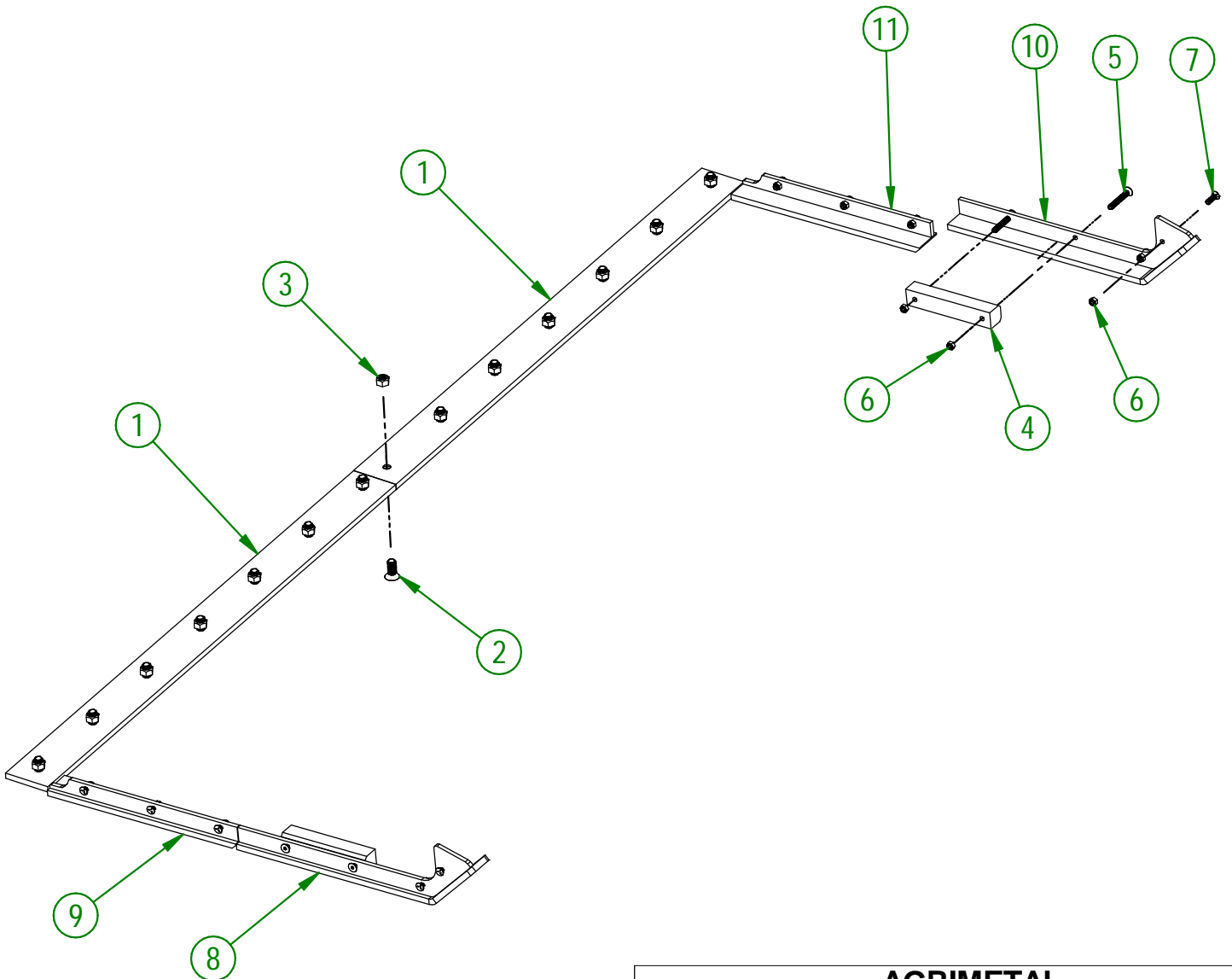

AGRIMETAL	
SET OF KNIVES (STAINLESS)	
CREATION : 06/03/23	ASSEMBLY : 84-57-0337
REVISION : 06/03/23	AUTHOR : D. CHASSÉ

#	PART #	Qty	TITLE
1	84-01-9155	2	COLLAR SUPPORT GUIDE ROD CLAMPING
2	84-20-9200	1	HYDRAULIC SKI PLATE
3	84-25-0000	5	HYDRAULIC SKI PIVOT WEAR RING
4	84-50-9150	5	ADJUSTABLE SKI RACK
5	84-50-9160	2	HYDRAULIC CYLINDER SUPPORT
6	84-50-9200	1	HYDRAULIC SKI
7	84-50-9205	1	CYLINDER SUPPORT REINFORCEMENT
8	NC01-25-0114	4	HEX. BOLT GR5 ZINC 3/8-16 X 1"
9	NC01-25-0115	20	HEX. BOLT GR5 ZINC 3/8-16 X 1 1/4"
10	NC01-25-0116	8	HEX. BOLT GR5 ZINC 3/8-16 X 1 1/2"
11	NC01-25-0398	5	HEX. BOLT GR5 ZINC 5/8-11 X 2 1/2" LG
12	NC01-69-0785	4	STRAIGHT GREASE FITTING 1/4-28
13	NC01-93-0010	16	LOCK NUT ZINC 5/16-18
14	NC01-93-0011	12	LOCK NUT 3/8-16
15	NC01-96-0016	5	NYLON INSERT NUT 5/8-11
16	NC02-25-0009	16	FLAT WASHER 14 GA X 13/16"OD X 25/64" ID
17	NC02-25-0009	20	FLAT WASHER 14 GA X 13/16"OD X 25/64" ID
18	NC02-32-0012	20	LOCK WASHER ZINC 3/8"
19	NC02-48-0021	16	FLAT HEAD SOCKET CAP SCREW 5/16-18 X 1"
20	NC13-45-0209	2	HYDRAULIC CYLINDER 6"

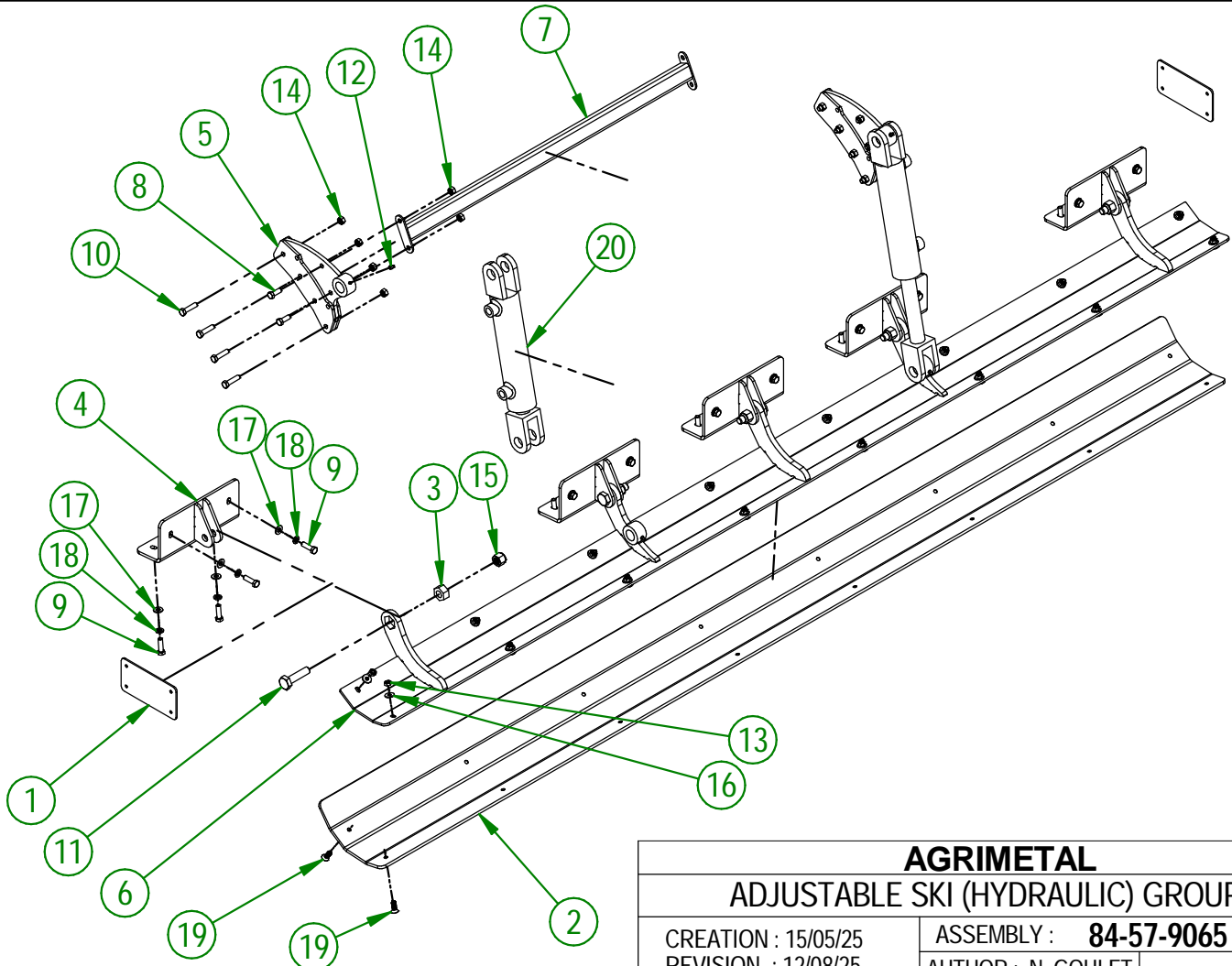
**AGRIMETAL****ADJUSTABLE SKI (HYDRAULIC) GROUP**

CREATION : 15/05/25
 REVISION : 12/08/25

ASSEMBLY : **84-57-9065**
 AUTHOR : N. GOULET

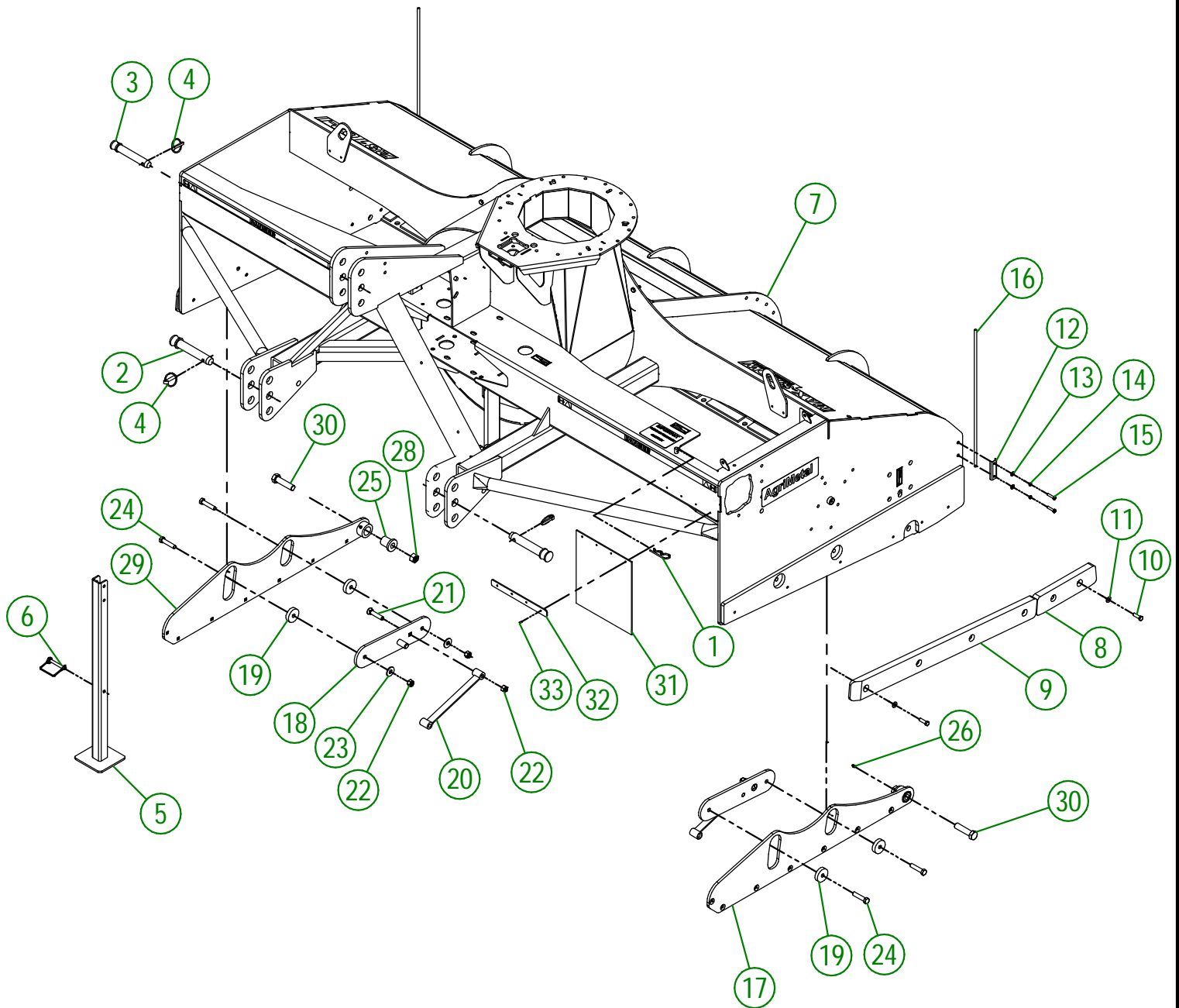

AGRIMETAL	
FRAME GROUP	
CREATION : 28/02/23	ASSEMBLY : 84-57-0346
REVISION : 06/01/26	AUTHOR : D. CHASSÉ

84-57-0346

#	PART #	Qty	TITLE
1	NC01-63-0026	1	COTTER PIN ZC 5/32" X 3"
2	48-20-0065	2	3 POINT PIN
3	48-20-0060	1	3 POINT PIN
4	NC01-69-1100	3	LINCH PIN 3/8"
5	84-50-0090	1	STAND
6	NC01-69-1306	1	LOCKING PIN 3/8" X 2 1/2" LG
7	84-57-0340	1	FRAME
8	84-42-0400	2	SIDE PROTECTION
9	84-42-0405	2	SIDE PROTECTION
10	NC01-17-0115	12	HEX. BOLT GR2 ZINC 3/8-16 X 1 1/4"
11	NC02-26-1525	12	WASHER INOX .406" D.I. X .815" D.E.
12	39-01-2440	2	GUIDE ROD CLAMP
13	NC02-25-0007	4	WASHER ZINC 0.281 = 9/32
14	NC02-32-0010	4	LOCK WASHER ZINC 1/4"
15	NC01-29-0007	4	HEX. BOLT GR5 NF ZINC 1/4-28 X 1 1/4"
16	39-42-0600	2	GUIDE ROD
17	84-50-0455	1	LEFT FLOATING SKATE HOLDER
18	84-50-0435	1	SPRING BLADE HOLDER (RIGHT)
19	84-13-2065	4	FLOATING SKATE BUSHING
20	84-50-2005	2	SPRING BLADE
21	NC01-09-0034	2	PLOW BOLT GR5 1/2-13 X 2 1/2" LG
22	NC01-96-0014	6	NYLON-INSERT LOCKNUT ZINC 1/2-13
23	NC02-22-0012	4	WASHER ZINC 1/2 BOLT = 9/16"Ø X 1 3/8" OD
24	NC01-54-1252	4	HEX BOLT. GR2 STAINLESS 1/2-13 X 2 1/4"
25	84-13-2085	2	PIVOT BUSHING
26	NC01-69-0785	3	STRAIGHT GREASE FITTING 1/4-28
27	84-50-0430	1	SPRING BLADE HOLDER (LEFT)
28	NC01-93-0017	2	HEX. LOCKNUT STEEL NC Z 3/4-10
29	84-50-0460	1	RIGHT FLOATING SKATE HOLDER
30	NC01-25-0565	2	HEX. BOLT GR5 ZINC 3/4-10 X 3" LG.
31	NC13-15-0315	1	SNOW GUARD
32	82-01-0970	1	SNOW GUARD BRACE
33	NC01-78-0041	4	POP RIVET STAINLESS STEEL ROD STEEL .187" X .690"

84-57-0356

#	PART #	Qty	TITLE
1	84-01-0130	1	IMPELLER ACCESS DOOR
2	84-55-0110	5	CLAMPING KNOB
3	84-57-0350	1	IMPELLER ACCESS DOOR
4	NC01-17-0114	2	HEX. BOLT GR2 ZINC 3/8-16 X 1"
5	NC01-64-0005	5	OVAL SLEEVE (ALUMINUM)
6	NC02-26-1525	2	WASHER INOX .406" D.I. X .815" D.E.
7	NC02-32-0012	2	LOCK WASHER ZINC 3/8"

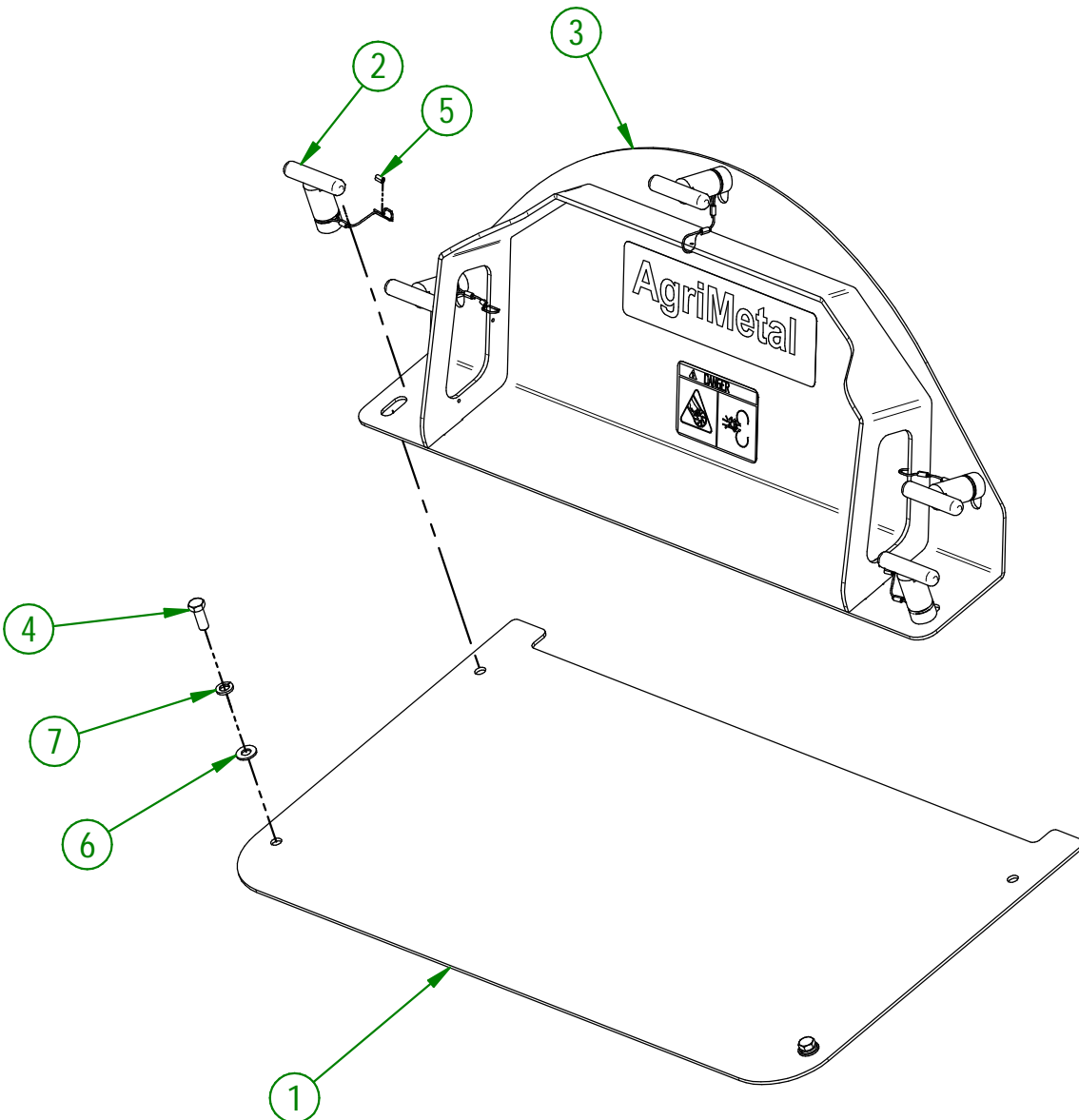

AGRIMETAL	
IMPELLER ACCESS DOOR GROUP	
CREATION : 28/02/23	ASSEMBLY : 84-57-0356
REVISION : 23/12/25	AUTHOR : J. Houle

81-57-0426

#	PART #	Qty	TITLE
1	81-50-0050	1	IMPELLER
2	NC02-32-0016	1	LOCK WASHER ZINC 5/8"
3	NC01-25-0395	1	HEX. BOLT GR5 ZINC 5/8-11 X 1 3/4" LG
4	80-04-0185	1	WASHER
5	NC01-37-0255	2	HEX BOLT GR8 1/2" X 3" LG.
6	NC01-94-0013	2	NYLON NUT ZINC 1/2-20"

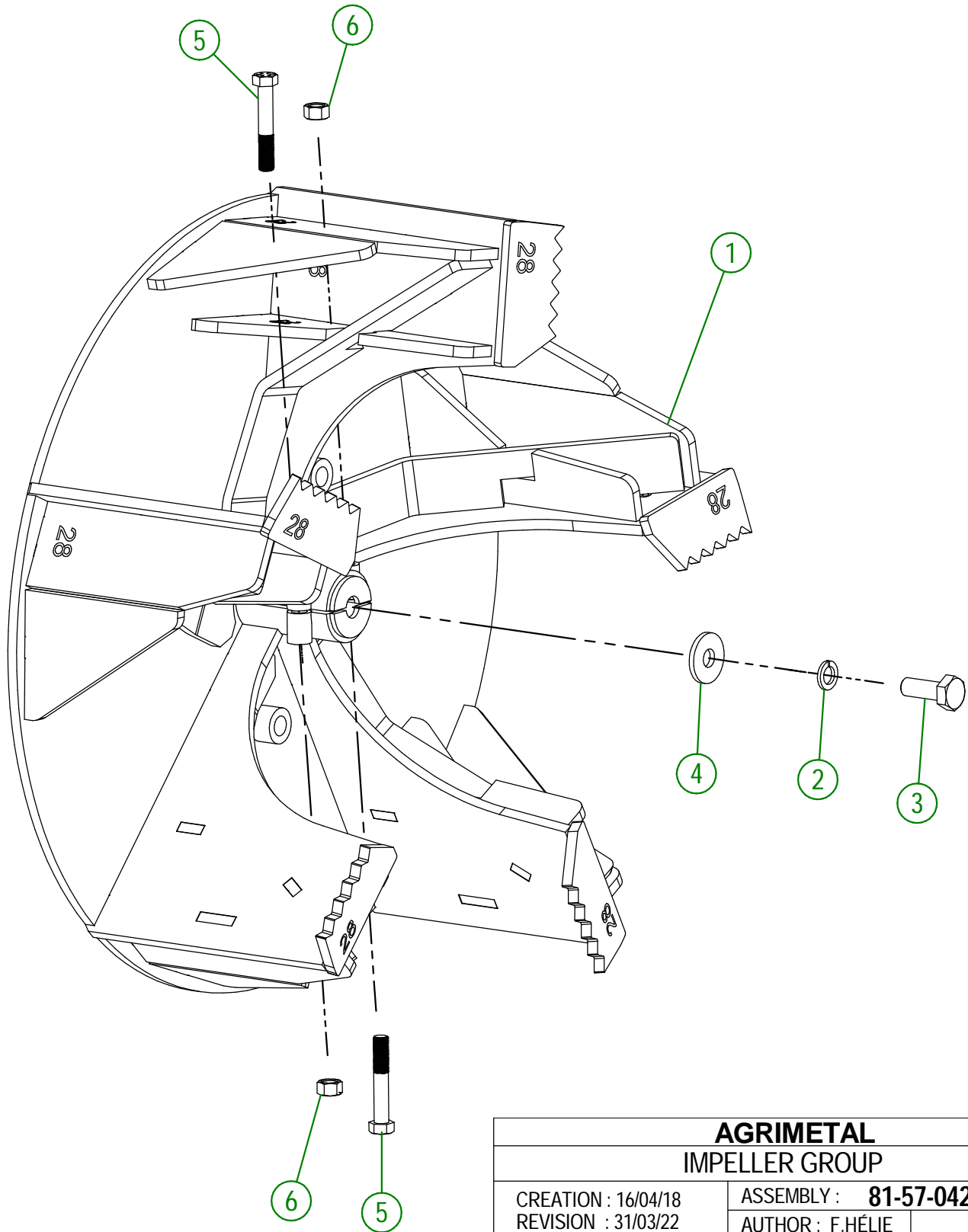

AGRIMETAL	
IMPELLER GROUP	
CREATION : 16/04/18	ASSEMBLY : 81-57-0426
REVISION : 31/03/22	AUTHOR : F.HÉLIE

84-57-0321

#	PART #	Qty	TITLE
1	NCI4-75-0161	2	FLANGE BEARING UCF 208-24 1 1/2" ID
2	84-50-0417	1	SPIRAL
3	NC02-25-0013	8	WASHER ZINC SAE ZINC 21/32 ID
4	NC01-17-0396	8	HEX. BOLT GR2 ZINC 5/8-11 X 2"
5	NC02-32-0016	8	LOCK WASHER ZINC 5/8"
6	NC02-07-0022	8	HEX. NUT ZINC 5/8-11
7	81-01-1511	1	ALIGNMENT SHIM
8	NCI4-55-0275	1	80A34 SPROCKET
9	NC01-29-0249	4	HEX. BOLT GR5 ZINC 1/2-20 X 1 1/2
10	NC01-94-0013	4	JAM NUT 1/2-20
11	102-51-1070	1	SHAFT OF THE SPIRAL
12	84-51-0360	1	SHAFT OF THE SPIRAL (SPROCKET)

REBUILD KIT

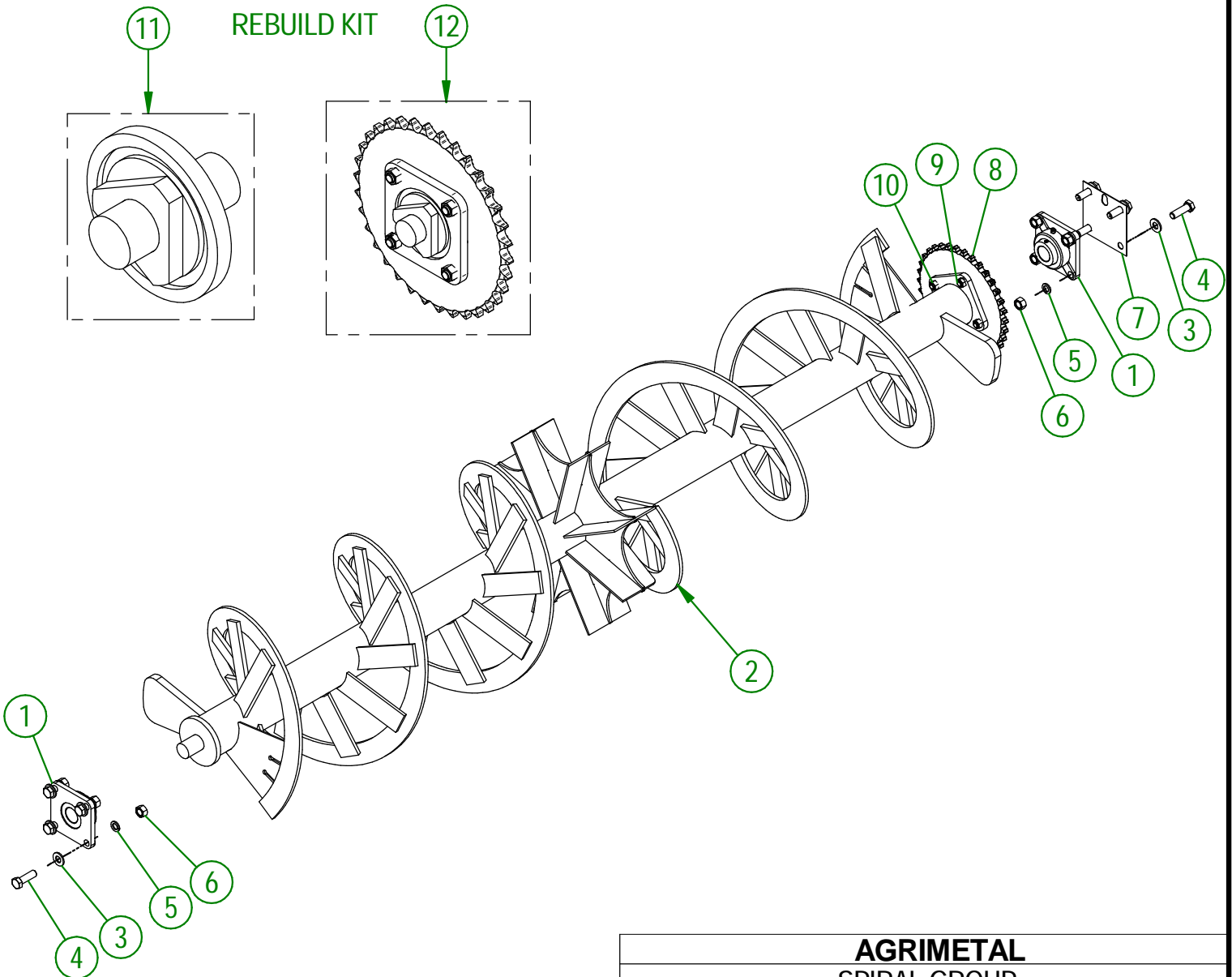

AGRIMETAL
SPIRAL GROUP

CREATION : 01/03/23
REVISION : 04/07/23

ASSEMBLY : **84-57-0321**
AUTHOR : J. Houle

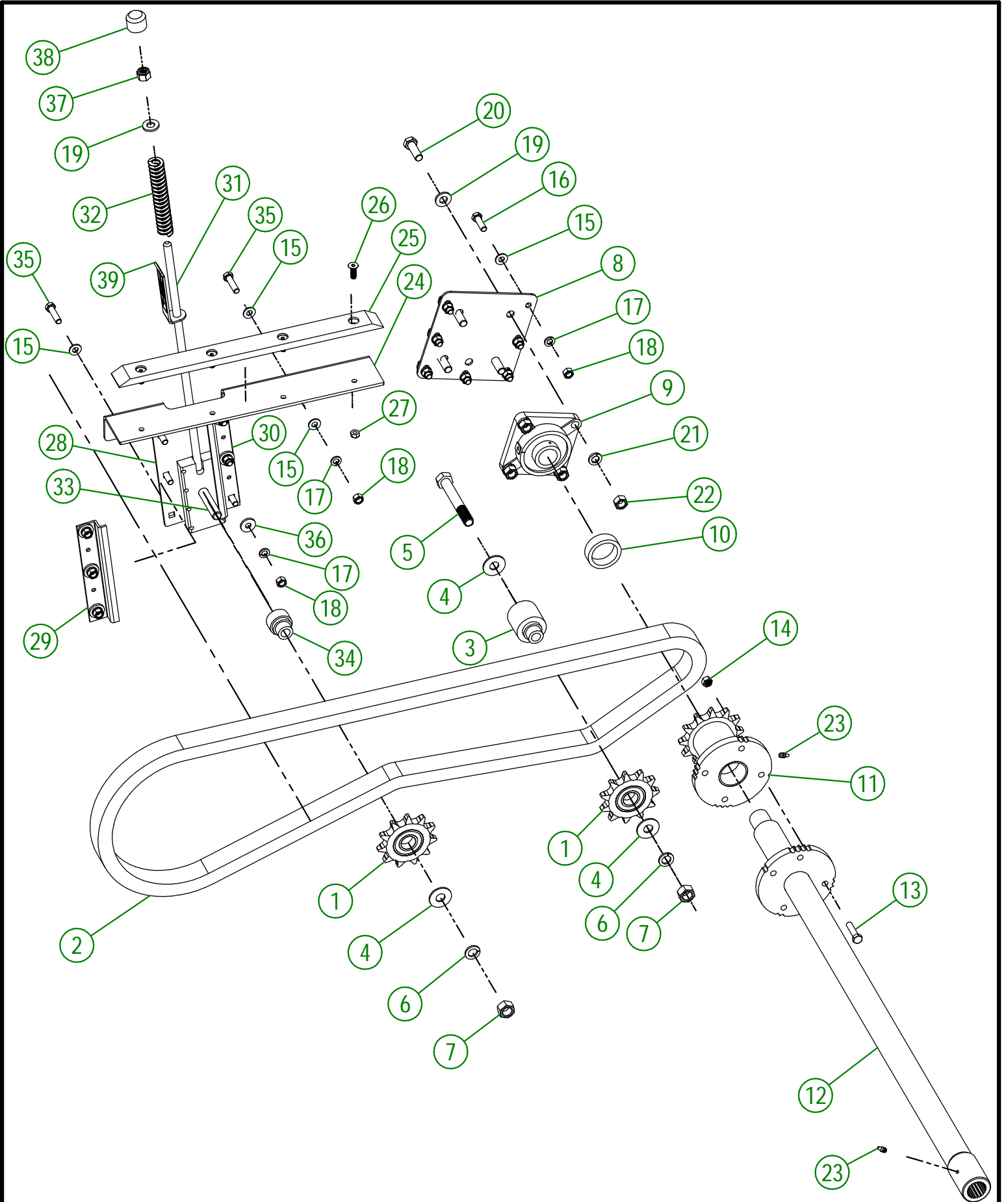

AGRIMETAL	
SPIRAL DRIVE TRAIN GROUP	
CREATION : 28/02/23	ASSEMBLY : 84-57-0366
REVISION : 23/12/25	AUTHOR : D. CHASSÉ

84-57-0366

#	PART #	Qty	TITLE
1	81-55-0005	2	CHAIN TENSIONER SPROCKET
2	84-37-1010	1	#80 CHAIN
3	81-21-0002	1	CHAIN TENSIONER BUSHING
4	NC02-22-0013	3	WASHER ZINC 5/8 ID X 1 1/2 OD
5	NC01-17-0406	1	HEX. BOLT GR2 ZINC 5/8-11 X 4 1/2"
6	NC02-32-0016	2	LOCK WASHER ZINC 5/8"
7	NC02-10-0022	2	HEX. NUT ZINC 5/8-18
8	84-01-0905	1	COUNTER SHAFT BEARING SUPPORT
9	NC14-75-0024	1	FLANGE BEARING 4 HOLES UCF207-20 1 1/4" DIA.
10	84-24-0005	1	SPIRAL DRIVE TRAIN BUSHING
11	NC14-55-0328	1	SPROCKET
12	84-50-0480	1	SPIRAL DRIVE TRAIN
13	NC01-25-0116	1	HEX. BOLT GR5 ZINC 3/8-16 X 1 1/2"
14	NC01-93-0011	1	LOCK NUT 3/8-16
15	NC02-26-1525	19	WASHER INOX .406" D.I. X .815" D.E.
16	NC01-17-0115	7	HEX. BOLT GR2 ZINC 3/8-16 X 1 1/4"
17	NC02-32-0012	16	LOCK WASHER ZINC 3/8"
18	NC02-07-0018	16	HEX. NUT ZINC 3/8-16
19	NC02-25-0011	5	WASHER SAE ZINC 17/32 ID
20	NC01-17-0249	4	HEX. BOLT GR2 ZINC 1/2-13 X 1 1/2"
21	NC02-32-0014	4	LOCK WASHER ZINC 1/2"
22	NC02-07-0020	4	HEX. NUT ZINC 1/2-13
23	NC01-69-0785	2	STRAIGHT GREASE FITTING 1/4-28
24	84-04-0575	1	WEAR STRIP SUPPORT
25	102-42-0010	1	SLIDING CHAIN STRIP
26	NC02-48-0021	4	FLAT HEAD SOCKET CAP SCREW 5/16-18 X 1"
27	NC01-93-0010	4	LOCK NUT ZINC 5/16-18
28	102-04-0180	1	CHAIN TENSIONER HOLD DOWN PLATE
29	81-01-0927	1	SUPPORT FOR CHAIN TENSIONER
30	81-01-0928	1	SUPPORT FOR CHAIN TENSIONER
31	84-50-0321	1	SUPPORT FOR CHAIN TENSIONER
32	NC13-86-0054	1	BLUE SPRING 1/2" ID X 1" OD X 6" LG
33	NC01-29-0400	1	HEX. BOLT GR5 ZINC 5/8-18 X 3"
34	102-21-0015	1	CHAIN TENSIONER BUSHING
35	NC01-17-0116	9	HEX. BOLT GR2 ZINC 3/8-16 X 1 1/2"
36	21-01-0950	6	FLAT WASHER 10GA 1.005" DIA X 25/64"
37	NC01-96-0014	1	NYLON-INSERT LOCKNUT ZINC 1/2-13
38	80-42-0110	1	THREADED ROD CAP
39	83-57-0160	1	ADJUSTMENT INDICATOR

84-57-0725

#	PART #	Qty	TITLE
1	NC02-26-1525	4	WASHER INOX .406" D.I. X .815" D.E.
2	NC01-17-0114	2	HEX. BOLT GR2 ZINC 3/8-16 X 1"
3	NC01-96-0011	2	NYLON NUT 3/8-16
4	84-57-0720	1	CHAIN GUARD

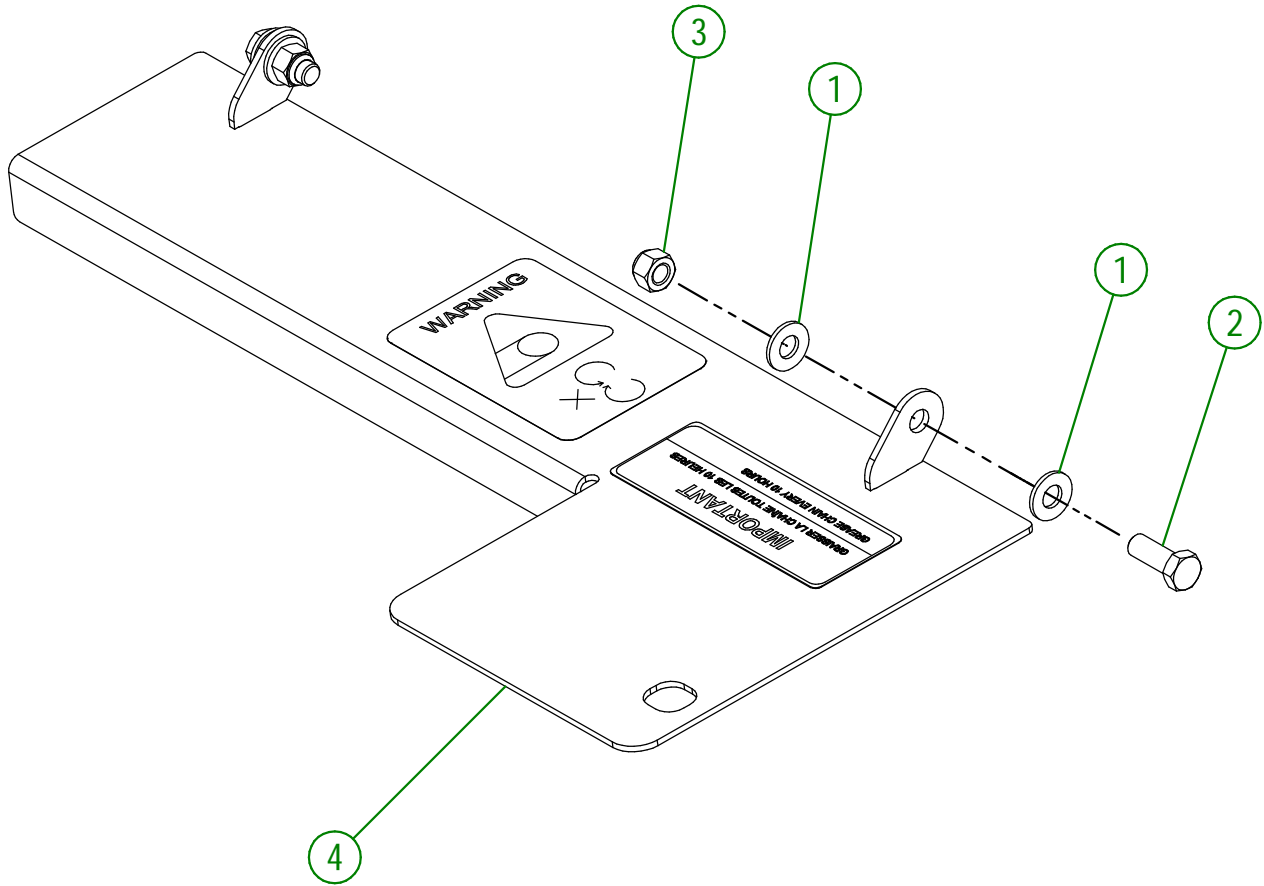

AGRIMETAL	
CHAIN GUARD GROUP	
CREATION : 31/03/22	ASSEMBLY : 84-57-0725
REVISION : 23/12/25	AUTHOR : J. Houle

#	PART #	Qty	TITLE
1	84-55-0010	1	GEARBOX
2	NC02-25-0011	14	WASHER SAE ZINC 17/32 ID
3	NC02-32-0014	12	LOCK WASHER ZINC 1/2"
4	NC01-33-0248	8	HEX. BOLT .GR8 NC ZINC 1/2-13 X 1 1/4"
5	80-41-0135	1	PTO GUARD STEEL CABLE
6	NC01-64-0005	2	OVAL SLEEVE (ALUMINUM)
7	80-41-0900	1	IMPELLER KEY
8	NC13-25-0019	1	BLACK TIE RAP
9	NC13-50-0110	1	IMPORTANT/NOTICE PTO POSTER
10	81-57-0040	1	PTO GUARD
11	84-01-0095	1	PTO GUARD SUPPORT
12	80-04-0485	1	GEARBOX BRACE
13	80-04-0480	1	GEARBOX BRACE
14	NC01-33-0249	4	CAP SCREW GR8 NC ZINC 1/2-13 X 1 1/2" LG
15	NC02-07-0020	4	HEX. NUT ZINC 1/2-13
16	NC01-63-0027	1	HAIRPIN COTTER
17	84-04-0660	2	GEARBOX SPACER
18	81-34-0035	1	PTO SHAFT T80

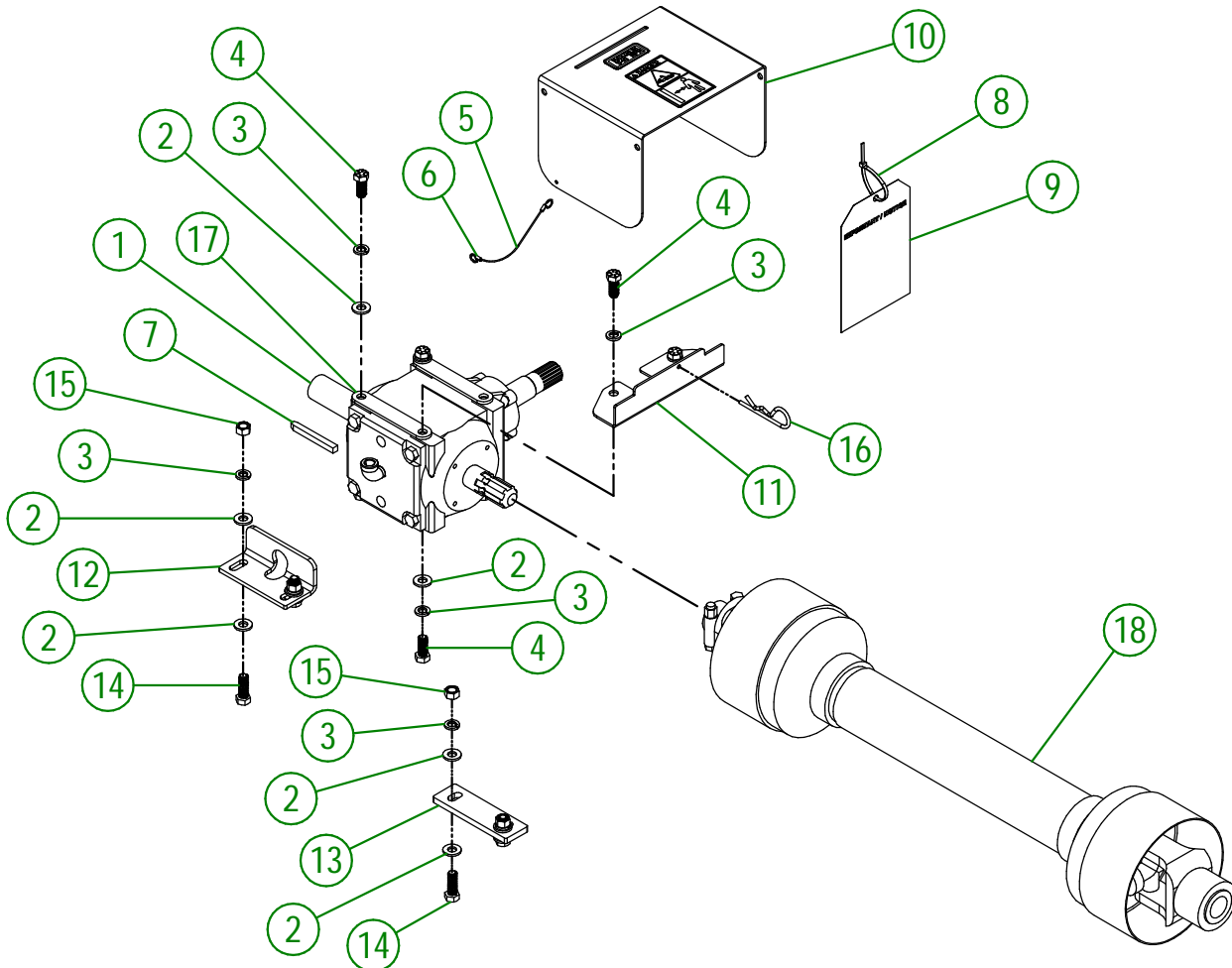

AGRIMETAL
GEARBOX GROUPING

CREATION : 31/03/22
REVISION : 31/03/22

ASSEMBLY : **84-57-0280**
AUTHOR : J. Houle

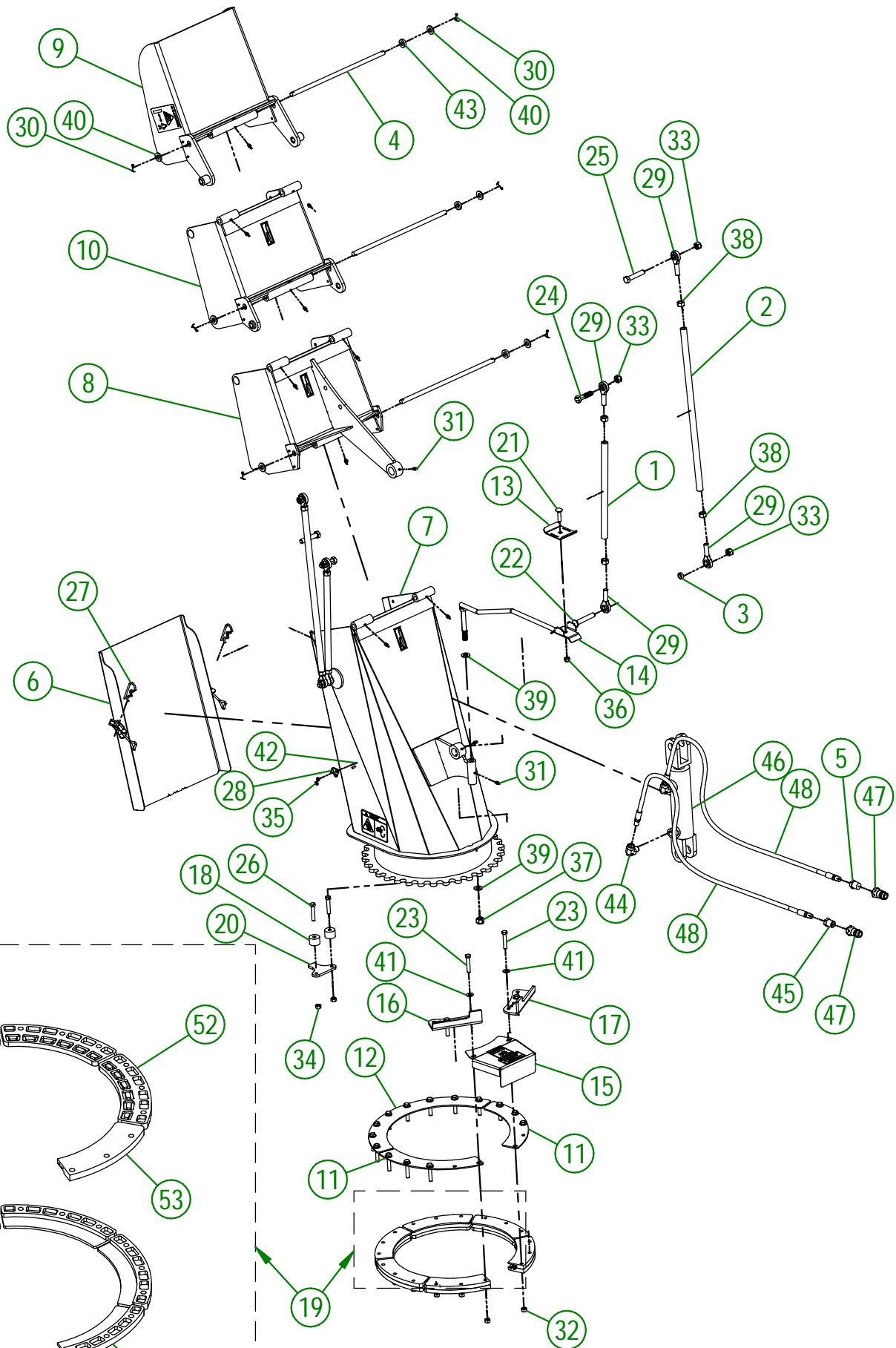

AGRIMETAL
CHUTE GROUP

CREATION : 19/09/23
 REVISION : 12/03/26

ASSEMBLY : **103-57-0016**
 AUTHOR : D. CHASSÉ

103-57-0016

#	PART #	Qty	TITLE
1	103-13-0000	2	CHUTE ROD (TRIPLE)
2	103-13-0005	2	CHUTE ROD (TRIPLE)
3	103-13-0025	2	CHUTE ROD SPACER
4	103-20-0010	3	PIVOT
5	103-25-0000	1	1/2 NPT STRAIGHT UNION X 3/64"
6	103-57-0041	1	CHUTE DOOR
7	103-57-0051	1	CHUTE BASE
8	103-57-0056	1	FIRST SECTION "STICKERS INCL."
9	103-57-0061	1	THIRD SECTION "STICKERS INCL."
10	103-57-0215	1	SECOND SECTION "STICKERS INCL"
11	48-01-1165	2	BRACE
12	48-01-1167	1	BRACE
13	48-01-7531	1	HYDRAULIC HOSE SUPPORT
14	48-50-1031	1	HYDRAULIC HOSE SUPPORT
15	80-57-0550	1	SPROCKET GUARD GROUP "STICKER INCLUDED"
16	81-04-0175	1	ADJUSTABLE STOPPER
17	81-04-0177	1	ADJUSTABLE STOPPER
18	81-21-0040	2	ADJUSTABLE STOPPER SPACER
19	81-57-0550	1	CHUTE GUIDE GROUP
20	84-04-0170	1	STOPPER
21	NC01-07-0111	1	CARR. BOLT GR5 ZINC 3/8-16 X 1 1/2"
22	NC01-07-0241	2	CARR. BOLT GR5 ZINC 1/2-13 X 3" LG
23	NC01-17-0118	18	HEX. BOLT GR2 ZINC 3/8-16 X 2"
24	NC01-25-0251	2	HEX.BOLT GR5 NC ZINC 1/2-13 X 2"
25	NC01-25-0253	2	HEX. BOLT GR5 NC ZINC 1/2-13 X 2 1/2"
26	NC01-37-0118	2	HEX. BOLT GR8 ZINC 3/8-24 X 2"
27	NC01-63-0026	2	COTTER PIN ZC 5/32" X 3"
28	NC01-63-0052	2	ADJUSTABLE LATCH (STRIKE)
29	NC01-67-0306	8	1/2-20 ROD END
30	NC01-69-0139	6	COTTER PIN ZINC 1/8" X 3/4"
31	NC01-69-0785	12	STRAIGHT GREASE FITTING 1/4-28
32	NC01-93-0011	18	LOCK NUT 3/8-16
33	NC01-93-0014	6	LOCK NUT ZINC 1/2-13
34	NC01-94-0011	2	LOCK NUT 3/8-24
35	NC01-96-0006	4	NYLON NUT ZINC 3/16
36	NC01-96-0011	1	NYLON NUT 3/8-16
37	NC01-96-0014	1	NYLON-INSERT LOCKNUT ZINC 1/2-13
38	NC02-10-0020	8	HEX. NUT ZINC 1/2-20
39	NC02-25-0011	2	WASHER SAE ZINC 17/32 ID
40	NC02-25-0011	6	WASHER SAE ZINC 17/32 ID
41	NC02-26-1525	18	WASHER INOX .406" D.I. X .815" D.E.
42	NC02-40-0080	4	MACHINE SCREWS SQUARE SOCKET #10-24 X 1/2" LG
43	NC13-15-0334	6	PIVOT WASHER
44	NC13-45-0038	2	ELBOW 90 3/8 FEM. NPT X 3/8 MALE NPT
45	NC13-45-0153	1	HEX. REDUCER 1/4 NPT X 1/2 NPT
46	NC13-45-0217	1	HYDRAULIC CYLINDER 4" STROKE

103-57-0016

#	PART #	Qty	TITLE
47	NC13-45-0369	2	QUICK COUPLER 1/2-14 NPTF
48	NC17-02-0347	2	HYDRAULIC HOSE (111" LG)

81-57-0550

#	PART #	Qty	TITLE
49	NC17-46-0025	4	CHUTE GUIDE (UNDER)
50	48-42-0305	1	CHUTE GUIDE (UNDER)
51	48-42-0310	1	CHUTE GUIDE (UNDER)
52	NC17-46-0026	4	CHUTE GUIDE (TOP)
53	48-42-0320	1	CHUTE GUIDE (TOP)
54	48-42-0315	1	CHUTE GUIDE (TOP)

#	PART #	Qty	TITLE
1	48-01-7527	1	HYDRAULIC HOSE SUPPORT
2	48-50-1025	1	HYDRAULIC ENGINE SPROCKET
3	80-13-0100	2	HYDRAULIC RESTRICTOR
4	80-45-0000	2	HEX. REDUCER 1/4 NPT X 1/2 NPT
5	81-01-7600	1	HYDRAULIC HOSE SUPPORT
6	NC01-07-0111	1	CARR. BOLT GR5 ZINC 3/8-16 X 1 1/2"
7	NC01-17-0115	2	HEX. BOLT GR2 ZINC 3/8-16 X 1 1/4"
8	NC01-33-0113	4	HEX.BOLT GR8 ZINC 3/8-16 X 3/4"
9	NC01-45-0184	1	HEX. BOLT GR8.8 ZINC 8MM X 20MM
10	NC01-96-0011	1	NYLON NUT 3/8-16
11	NC02-07-0018	2	HEX. NUT ZINC 3/8-16
12	NC02-26-0504	1	WASHER
13	NC02-26-1525	2	WASHER INOX .406" D.I. X .815" D.E.
14	NC02-32-0011	1	LOCK WASHER ZINC 5/16"
15	NC02-32-0012	6	LOCK WASHER ZINC 3/8"
16	NC02-44-0103	2	SET SCREW 5/16-18 X 3/8"
17	NC13-45-0367	2	45°-7/8-14 MALE O RING X 1/2 FEM.TOUR.NPT PT
18	NC13-45-0369	2	QUICK COUPLER 1/2-14 NPTF
19	NC13-45-0378	2	HYDRAULIC RESTRICTOR BUSHING
20	NC14-45-0156	1	HYDRAULIC MOTOR
21	NC17-02-0328	2	HYDRAULIC HOSE (63" LG)
22	NC17-46-0031	1	HYDRAULIC MOTOR BUSHING

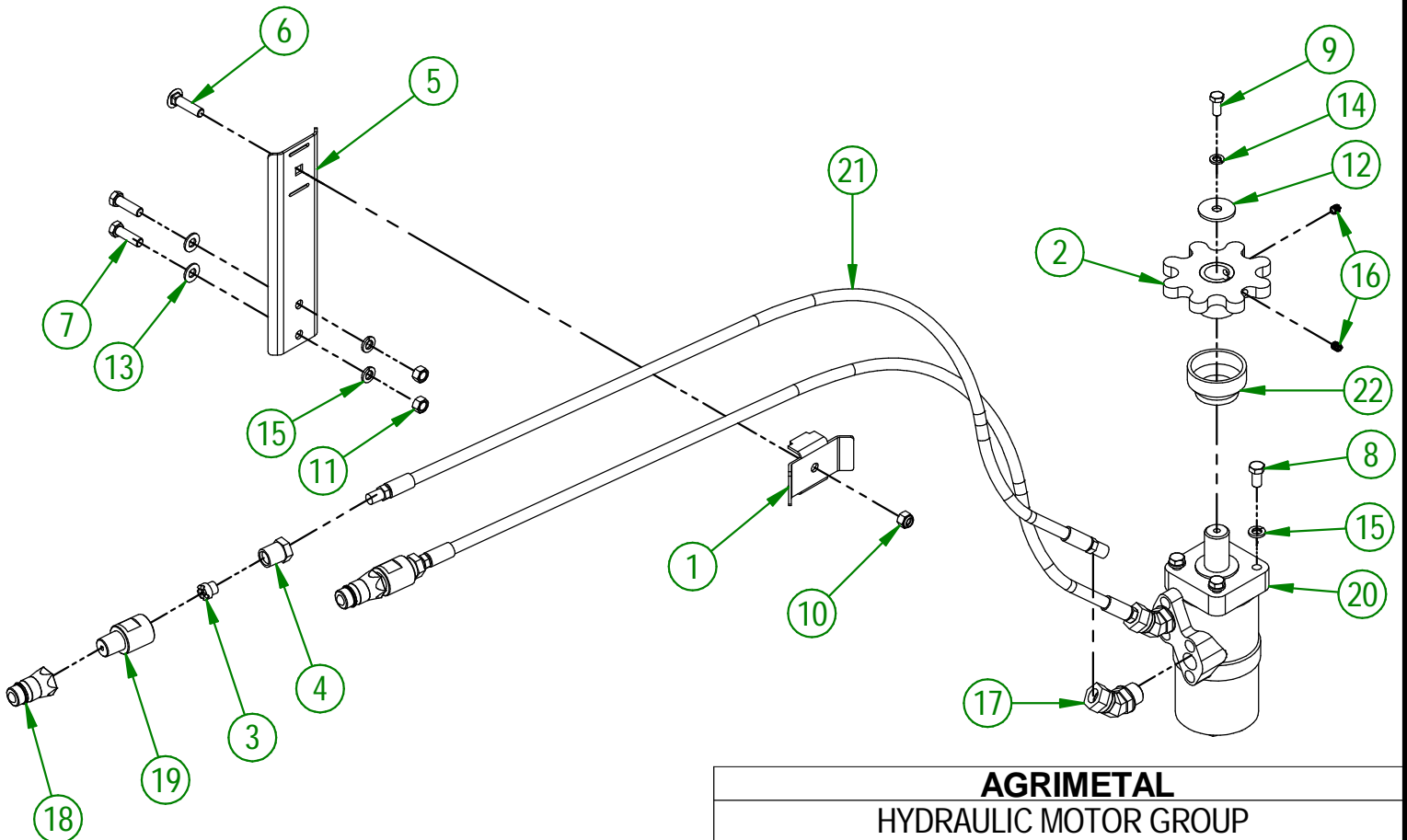

AGRIMETAL
HYDRAULIC MOTOR GROUP

CREATION : 05/08/19
 REVISION : 25/03/26

ASSEMBLY : **84-57-0410**
 AUTHOR : F.HÉLIE

#	PART #	Qty	TITLE
1	NC13-30-0237	1	PLASTIC TUBE FOR OPERATOR'S MANUAL
2	NC02-22-0008	2	WASHER ZINC 5/16"
3	NC01-17-0007	2	HEX. BOLT GR2 ZINC 1/4-20 X 1 1/4"
4	NC01-96-0009	2	NYLON-INSERT LOCKNUT ZINC 1/4-20
5	81-57-0030	1	SET OF 6 SHEAR BOLT WITH NUT
6	84-98-0520	1	ENGLISH OPERATOR'S MANUAL (MS2692-i, MS2482-i)

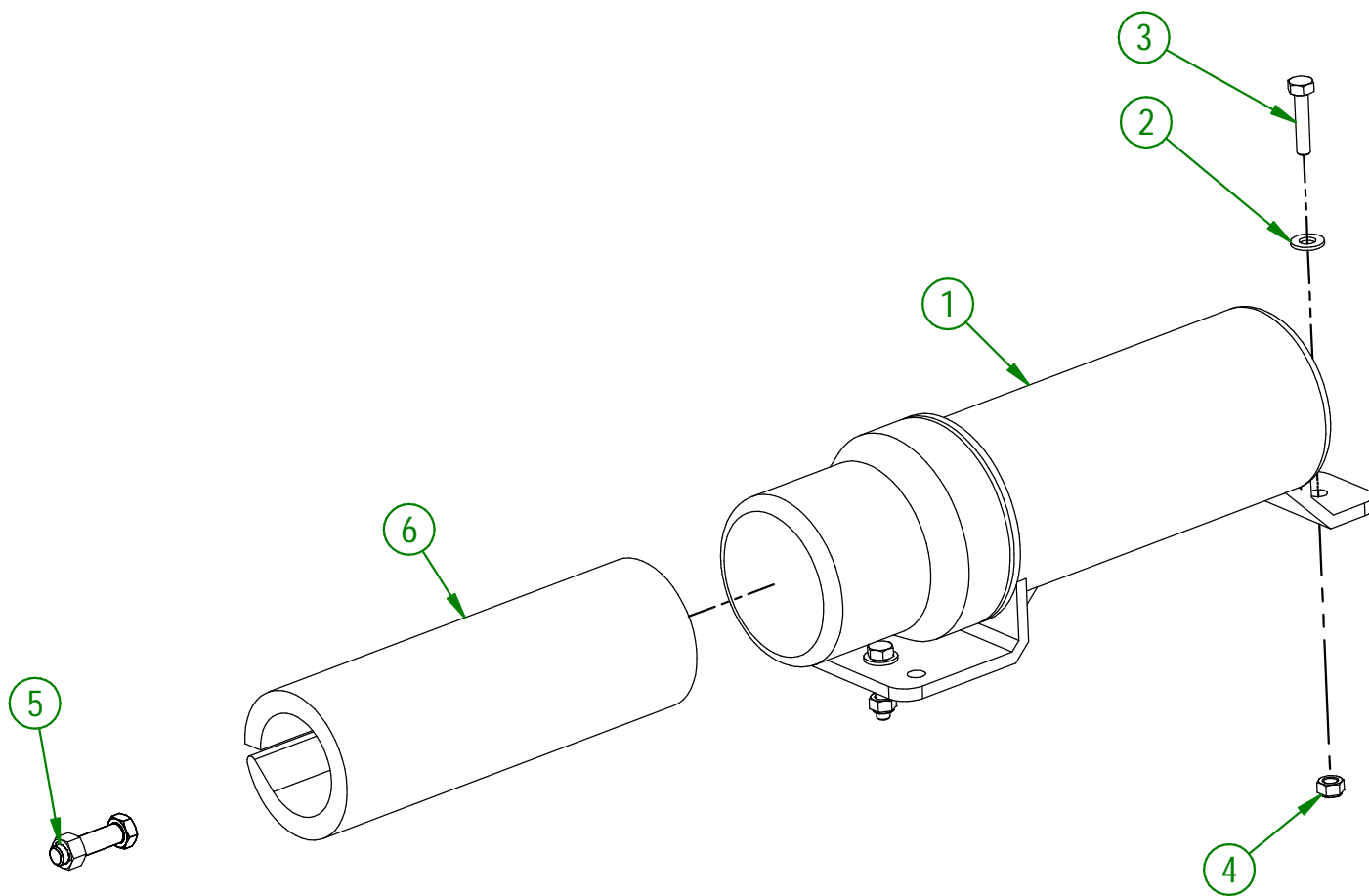

AGRIMETAL	
OPERATOR'S MANUAL TUBE GROUP	
CREATION : 03/01/18	ASSEMBLY : 84-57-1320
REVISION : 31/03/22	AUTHOR : F.HÉLIE

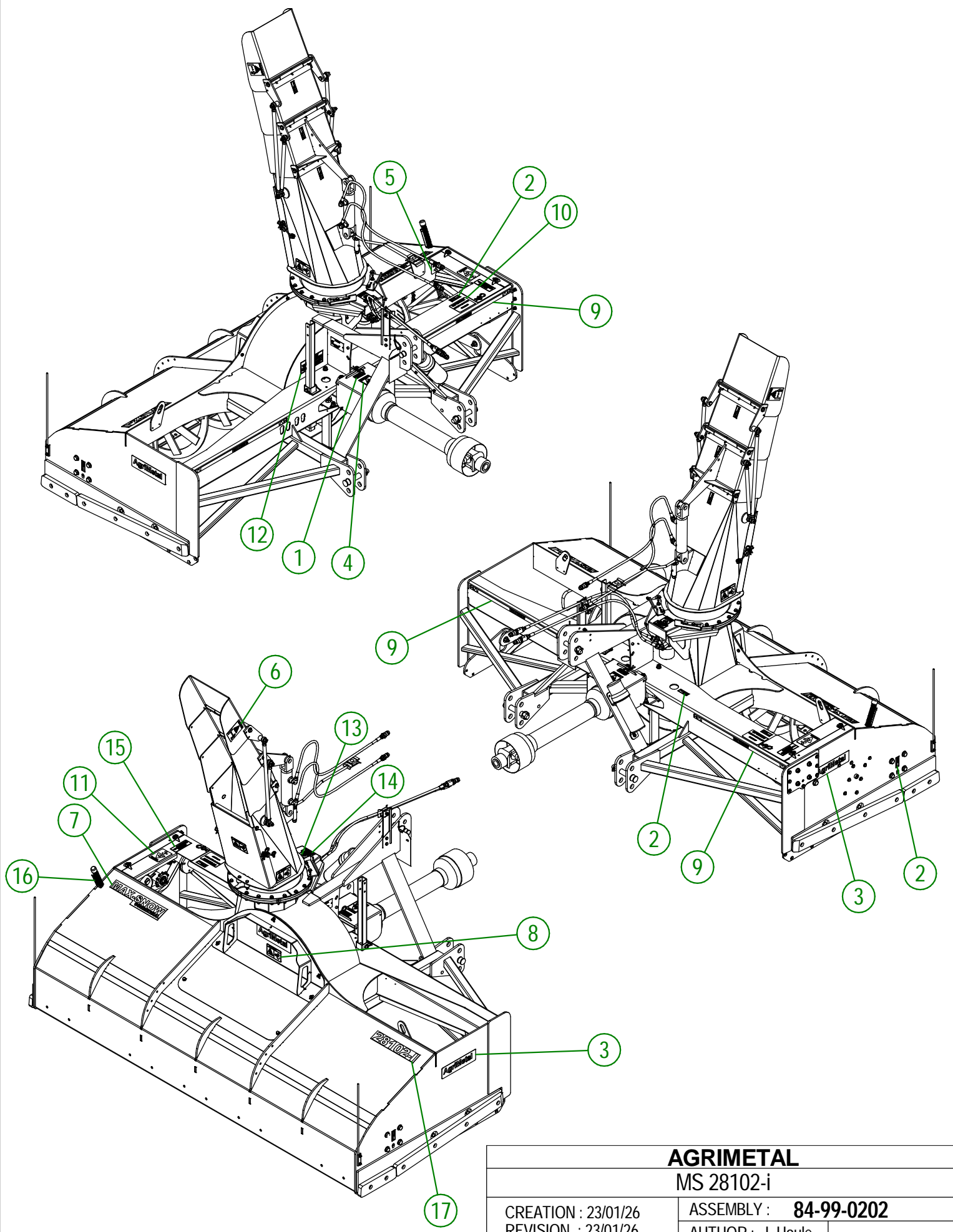

AGRIMETAL

MS 28102-i

CREATION : 23/01/26
 REVISION : 23/01/26

ASSEMBLY : **84-99-0202**
 AUTHOR : J. Houle

84-99-0202

#	PART #	Qty	TITLE
1	NC13-33-0005	1	STICKER MAXIMUM 540 RPM
2	NC13-33-0024	7	STICKER GREASE HERE
3	NC13-33-0035	3	STICKER AGRIMETAL
4	NC13-33-0187	1	STICKER DANGER (PTO AND PERSON)
5	NC13-33-0189	1	STICKER DANGER (PERSON AND CHAIN DRIVE)
6	NC13-33-0192	2	STICKER (PROJECTION RISK)
7	NC13-33-0241	1	STICKER MAX-SNOW COMMERCIAL
8	NC13-33-0249	4	STICKER DANGER
9	NC13-33-0274	2	STICKER DANGER
10	NC13-33-0281	1	STICKER SHEAR BOLT
11	NC13-33-0283	1	STICKER DANGER (PERSON AND CHAIN DRIVE)
12	NC13-33-0317	1	STICKER GREASE DRIVE LINE TELESCOPIC SHAFT
13	NC13-33-0326	1	STICKER DANGER (HAND)
14	NC13-33-0327	1	STICKER END ROTATION ADJUSTMENT
15	NC13-33-0343	1	GREASE CHAIN EVERY 10 HOURS STICKER
16	NC13-33-0344	1	ADJUSTEMENT INDICATOR STICKER
17	NC13-33-2653	1	STICKER 28102-i