

AgriMetal

PARTS LIST

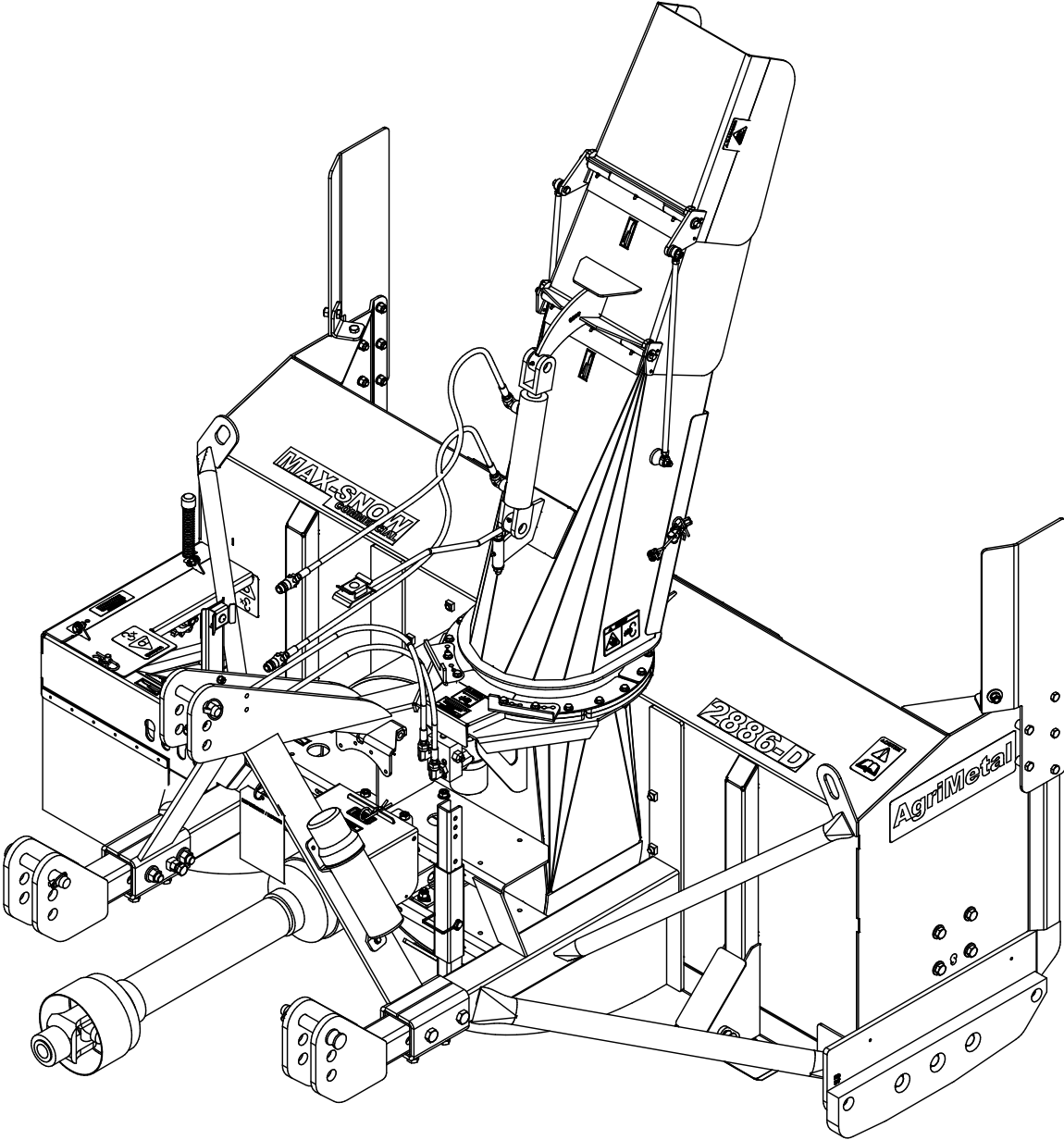

MS 2886-D

#	PART #	Qty	TITLE
1	81-50-0200	2	KNIFE BRACE (TOP)
2	81-42-0100	1	RIGHT KNIFE (UHMW)
3	81-42-0101	1	LEFT KNIFE (UHMW)
4	81-04-0355	2	KNIFE BRACE (UNDER)
5	NC01-93-0016	10	LOCK NUT ZINC 5/8-11
6	NC02-48-0564	10	FLAT HEAD SOCKET CAP SCREW STAINLESS 5/8-11 X 2" LG
7	81-42-0103	1	LATERAL KNIFE (RIGHT)
8	81-42-0104	1	LATERAL KNIFE (LEFT)
9	NC01-17-0394	6	HEX. BOLT GR2 ZINC 5/8-11 X 1 1/2"
10	80-04-0185	6	WASHER
11	NC02-25-0011	4	WASHER SAE ZINC 17/32 ID
12	NC01-17-0251	2	HEX. BOLT GR2 ZINC 1/2-13 X 2"
13	NC01-17-0250	2	HEX. BOLT GR2 ZINC 1/2-13 X 1 3/4"
14	NC01-93-0014	4	LOCK NUT ZINC 1/2-13

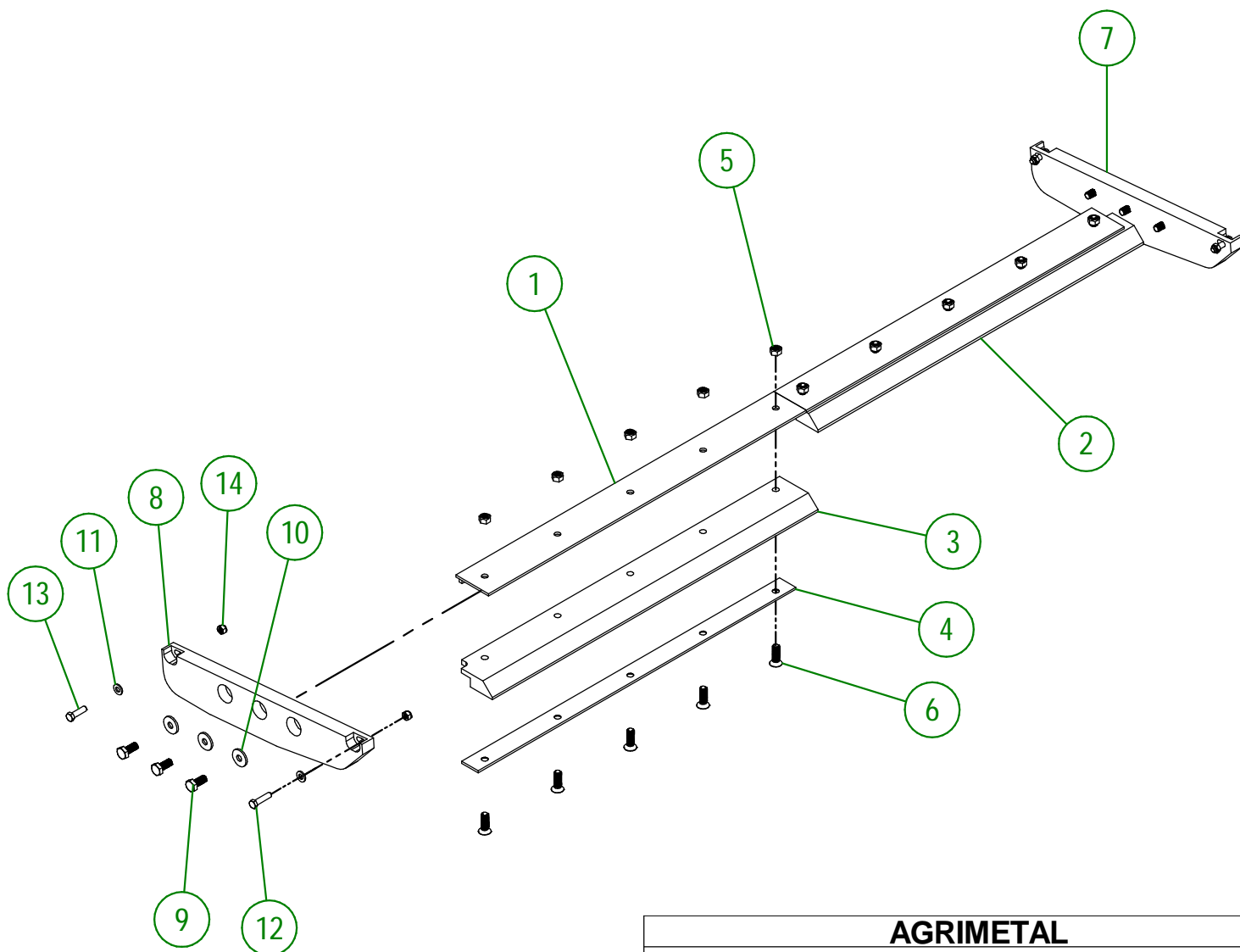

AGRIMETAL	
SET OF KNIVES (UHMW)	
CREATION : 18/07/16	ASSEMBLY : 81-57-0205
REVISION : 27/09/23	AUTHOR : J. HOULE

81-57-0200

#	PART #	Qty	TITLE
1	80-50-0085	2	LATERAL SKATE (#450 HARDNESS STEEL)
2	81-50-0055	2	ADJUSTABLE SKATE (#450 HARDNESS STEEL)
3	NC02-48-0586	4	FLAT HEAD SOCKET CAP SCREW 5/8-11 X 1" LG
4	81-57-0220	2	KNIFE (#450 HARDNESS STEEL) GROUP (BOLTS AND NUTS INCLUDED)
5	NC01-25-0481	2	HEX. BOLT GR5 NC 3/4-10 X 5"
6	NC01-96-0017	2	HEX. LOCK NUT NYLO. NC 3/4-10

81-57-0220

#	PART #	Qty	TITLE
7	NC01-09-0039	5	PLOW BOLT GR5 5/8-11 X 1 1/2" LG
8	NC01-93-0016	5	LOCK NUT ZINC 5/8-11

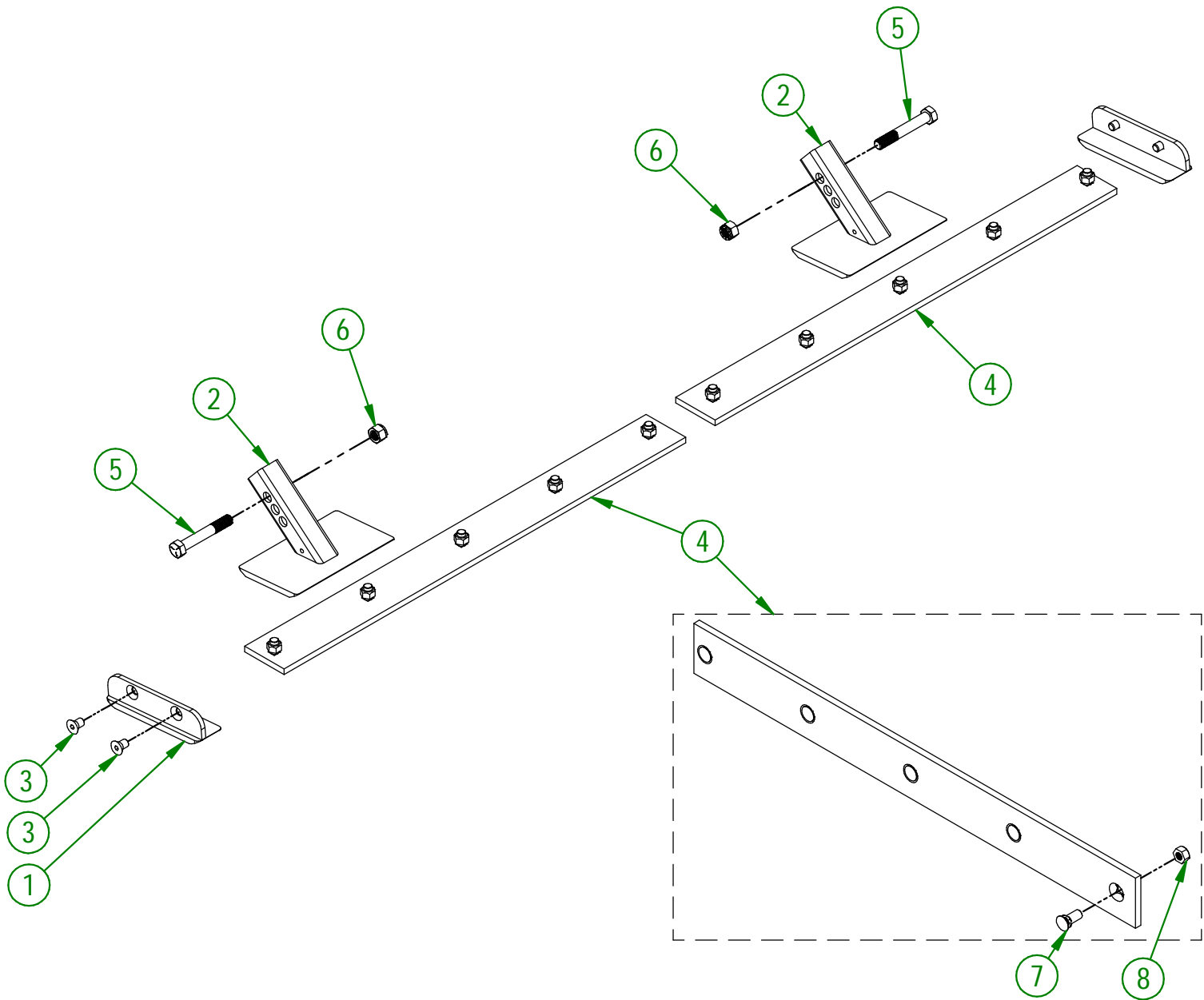

AGRIMETAL	
SET OF KNIVES (#450 HARDNESS STEEL)	
CREATION : 18/07/16	ASSEMBLY : 81-57-0200
REVISION : 20/05/25	AUTHOR : Dessin2

81-57-0210

#	PART #	Qty	TITLE
1	80-50-0087	2	LATERAL SKATE (STAINLESS STEEL)
2	81-50-0058	2	ADJUSTABLE SKATE (STAINLESS STEEL)
3	NC02-48-0586	4	FLAT HEAD SOCKET CAP SCREW 5/8-11 X 1" LG
4	81-57-0225	2	KNIFE (STAINLESS STEEL) GROUP (BOLTS AND NUTS INCLUDED)
5	NC01-25-0481	2	HEX. BOLT GR5 NC 3/4-10 X 5"
6	NC01-96-0017	2	HEX. LOCK NUT NYLO. NC 3/4-10

81-57-0225

#	PART #	Qty	TITLE
7	NC01-93-0016	5	LOCK NUT ZINC 5/8-11
8	NC02-48-0562	5	FLAT HEAD SOCKET CAP SCREW STAINLESS 5/8-11 X 1 1/2"

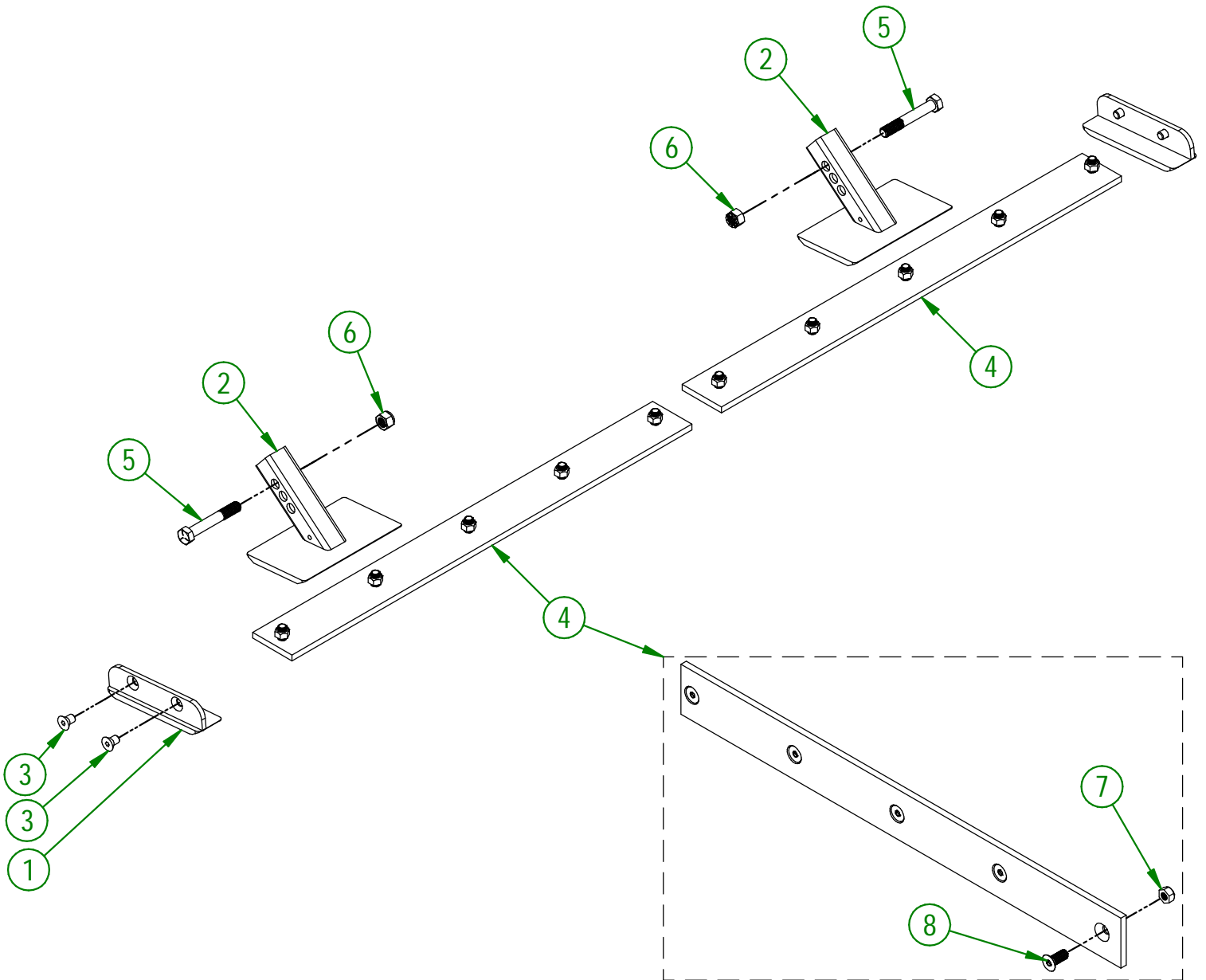

AGRIMETAL	
SET OF KNIVES (STAINLESS STEEL)	
CREATION : 18/07/16	ASSEMBLY : 81-57-0210
REVISION : 20/05/25	AUTHOR : Dessin2

81-57-0215

#	PART #	Qty	TITLE
1	81-20-0337	1	LATERAL CUTTER BLADES (LEFT)
2	81-20-0335	1	LATERAL CUTTER BLADES (RIGHT)
3	81-10-0000	4	LATERAL CUTTER BLADES BUSHING
4	NC01-33-0248	10	HEX. BOLT .GR8 NC ZINC 1/2-13 X 1 1/4"
5	NC01-33-0514	4	HEX. BOLT GR8 ZINC 1/2-13 X 2 1/4"
6	NC02-32-0014	14	LOCK WASHER ZINC 1/2"
7	NC02-07-0020	14	HEX. NUT ZINC 1/2-13
8	81-04-0525	2	LATERAL KNIFE REINFORCE
9	NC02-22-0012	2	WASHER ZINC 1/2 BOLT = 9/16"Ø X 1 3/8" OD

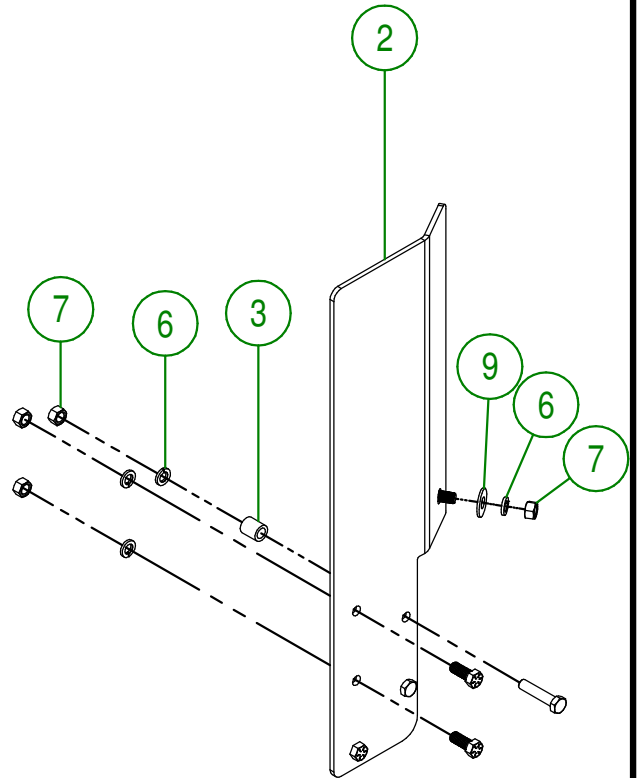
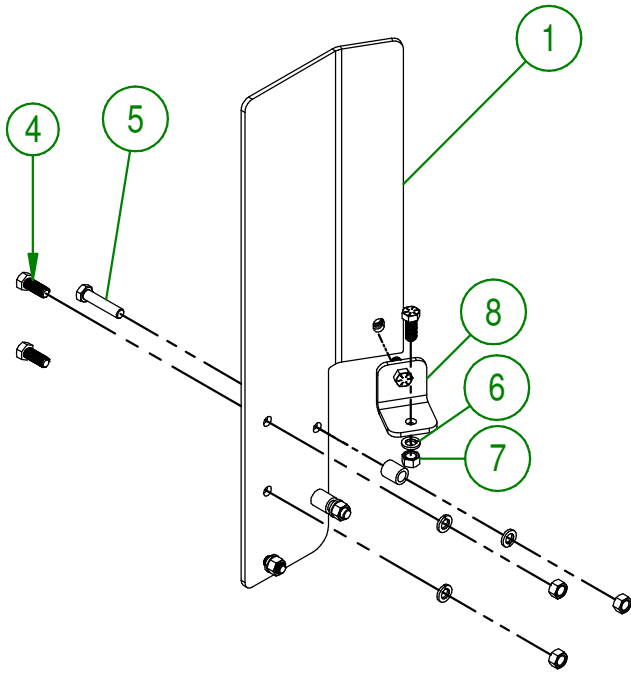

AGRIMETAL	
LATERAL CUTTER BLADES	
CREATION : 24/11/17	ASSEMBLY : 81-57-0215
REVISION : 06/12/21	AUTHOR : J. Houle

#	PART #	Qty	TITLE
1	81-21-0030	4	CHAIN CASE SUPPORT
2	81-55-5000	1	CHAIN CASE ASSY.
3	NC01-37-0124	4	HEX. BOLT GR8 3/8-24 X 3 1/2"
4	21-01-0950	8	FLAT WASHER 10GA 1.005" DIA X 25/64"
5	NC01-94-0011	4	LOCK NUT 3/8-24
6	NC02-26-1300	10	WASHER 17/32-.531"ID X 1 1/2"OD
7	NC01-37-0263	1	HEX. BOLT GR8 NF ZINC 1/2-20 X 5" LG
8	NC01-97-0008	1	HEX. LOCK NUT NYLO. NF Z 1/2-20
9	81-57-0045	1	PTO GUARD

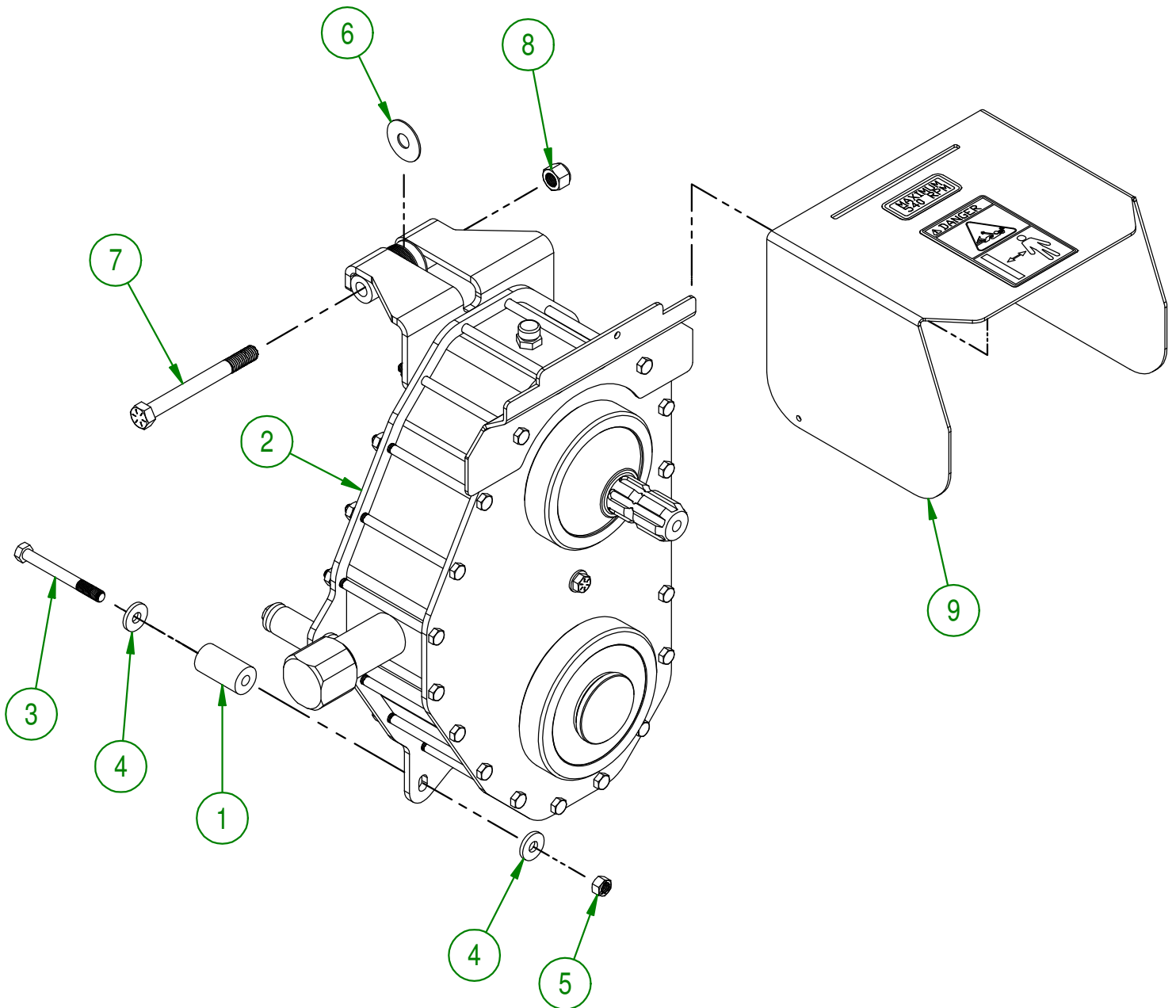

AGRIMETAL	
CHAIN CASE GROUP.	
CREATION : 09/04/18	ASSEMBLY : 81-57-5012
REVISION : 18/11/19	AUTHOR : J.KABWE Page 5 de 22

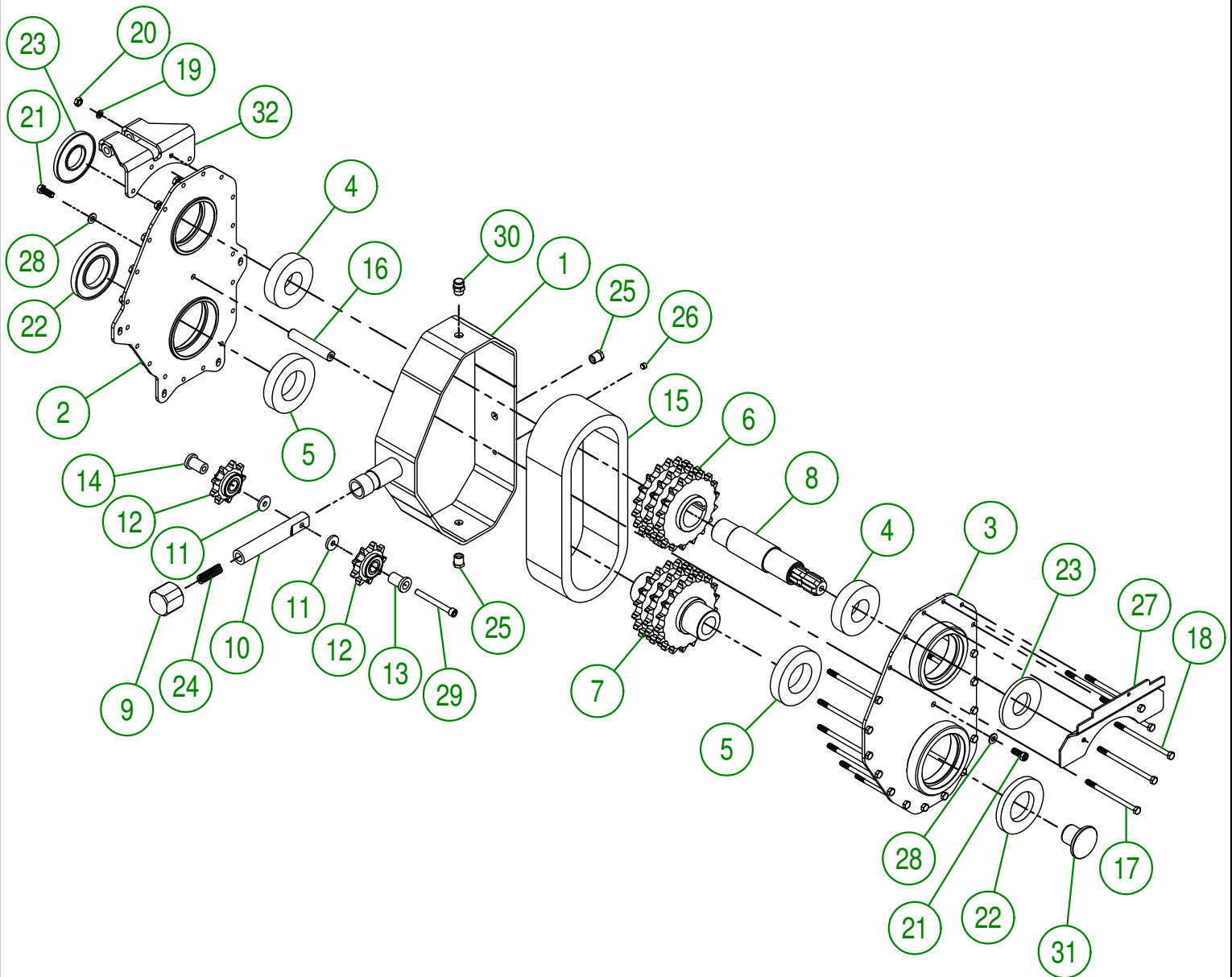

AGRIMETAL
CHAIN CASE ASSY.

CREATION : 09/04/18
 REVISION : 29/05/19

ASSEMBLY : **81-55-5000**

AUTHOR : J.KABWE

Page 6 de 22

#	PART #	Qty	TITLE
1	81-50-9000	1	CHAIN CASE SIDE
2	81-50-9005	1	CHAIN CASE BACK
3	81-50-9010	1	CHAIN CASE FRONT
4	NC14-75-0169	2	BEARING 6309-2RS
5	NC14-75-0168	2	BEARING 6212-2RS
6	81-50-9015	1	SPROCKET (TOP)
7	81-50-9020	1	SPROCKET (BOTTOM)
8	81-20-0040	1	SHAFT (CHAIN CASE)
9	81-21-0025	1	CHAIN CASE TIGHTENER PLUG
10	81-13-0005	1	SPRING
11	81-13-0015	2	SPACER
12	81-55-0000	2	CHAIN TENSIONER SPROCKET
13	81-13-0010	1	SPACER
14	81-13-0012	1	SPACER
15	81-37-1010	1	CHAIN #80 TRIPLE
16	81-13-0030	1	COVER BRACE
17	NC01-37-0076	15	HEX. BOLT ZINC GR8 5/16-24 X 5"
18	NC01-37-0078	4	HEX. BOLT ZINC GR8 5/16-24 X 5"
19	NC02-32-0011	19	LOCK WASHER ZINC 5/16"
20	NC02-11-0017	19	HEX. NUT 5/16-24
21	NC01-37-0114	2	BOLT GR8 3/8" X 1"
22	NC13-80-0281	2	SEALING GASKET 12mm X 60mm X 110mm
23	NC13-80-0280	2	SEALING GASKET 8mm X 45mm X 100mm
24	NC13-86-0008	1	BLUE SPRING (5/8" OD. X 4")
25	NC13-45-0221	2	HEXAGONAL PLUG
26	NC02-44-0202	1	PRESSURE SCREW 6PANS NPTF 1/8-27
27	81-01-0924	1	PTO GUARD SUPPORT (CHAIN CASE)
28	49-22-1810	2	WASHER
29	NC02-51-0128	1	SOCKET HAED SCREW 3/8-24 X 3 1/2"
30	NC14-10-0160	1	PLUG
31	81-42-0000	1	HUB PLUG
32	81-50-9025	1	CHAINCASE BRACE

AGRIMETAL
CHAIN CASE ASSY.

CREATION : 09/04/18
REVISION : 29/05/19

ASSEMBLY : **81-55-5000**

AUTHOR : J.KABWE

Page 7 de 22

#	PART #	Qty	TITLE
1	81-55-0100	1	1000 TO 540 RPM GEARBOX
2	NC02-32-0014	10	LOCK WASHER ZINC 1/2"
3	NC01-25-0248	8	HEX. BOLT GR5 ZINC 1/2-13 X 1 1/4"
4	01-01-0925	4	WASHER
5	NC01-25-0251	2	HEX.BOLT GR5 NC ZINC 1/2-13 X 2"
6	NC02-07-0020	2	HEX. NUT ZINC 1/2-13
7	NC02-22-0010	4	WASHER 13/32" ID
8	NC01-93-0011	4	LOCK NUT 3/8-16
9	81-13-0070	4	GEARBOX SPACER
10	NC01-07-0114	4	CARR. BOLT GR5 ZINC 3/8-16 X 2" LG
11	81-50-2080	1	GEARBOX HOLDER
12	81-57-0040	1	PTO GUARD
13	81-01-0235	1	PTO GUARD SUPPORT (GEARBOX)
14	NC01-63-0027	1	HAIRPIN COTTER

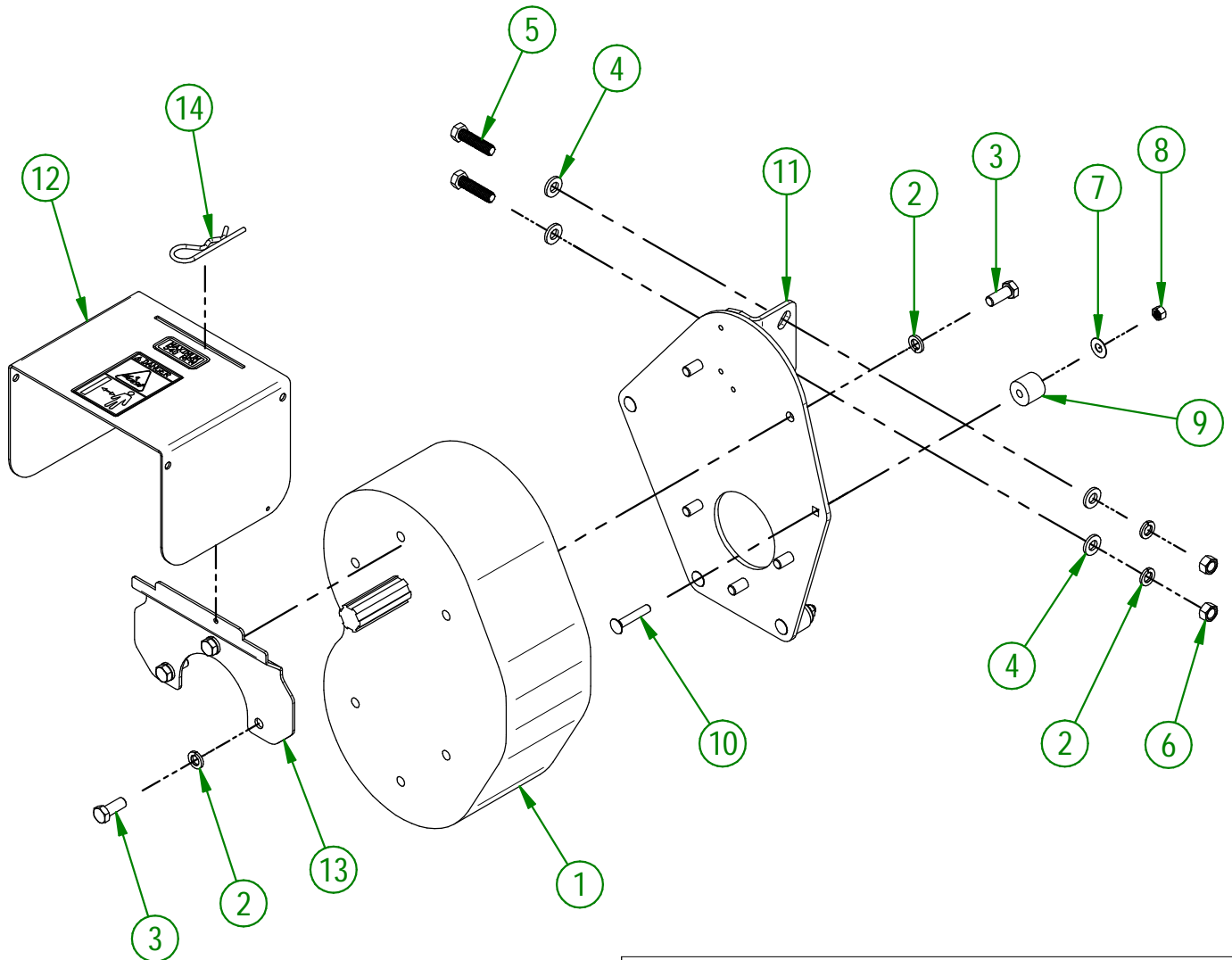

AGRIMETAL	
1000 TO 540 RPM GEARBOX GROUP	
CREATION : 22/02/22	ASSEMBLY : 81-57-5075
REVISION : 02/06/22	AUTHOR : J. Houle

#	PART #	QTY	TITLE
1	81-50-0090	1	STAND
2	NC01-63-0026	1	COTTER PIN ZC 5/32" X 3"
3	48-20-0065	2	3 POINT PIN
4	NC01-69-1100	3	LINCH PIN 3/8"
5	48-20-0060	1	3 POINT PIN
6	NC01-69-1306	1	LOCKING PIN 3/8" X 2 1/2" LG
7	NCI3-15-0300	1	SNOW GUARD
8	NC01-78-0041	6	POP RIVET STAINLESS STEEL ROD STEEL .187" X .690"
9	80-01-1075	1	SNOW GUARD BRACE
10	NC01-33-0481	4	HEX. BOLT GR8 ZINC 3/4-10 X 5 1/2"
11	22-04-6805	4	FLAT WASHER BEARING BASE
12	NC01-93-0017	4	HEX. LOCKNUT STEEL NC Z 3/4-10
13	81-57-5015	1	FRAME
14	81-50-5040	2	ATTACHMENT HAND
15	NCI3-15-0321	1	RUBBER
16	NC01-17-0060	7	HEX. BOLT GR2 ZINC 5/16-18 X 1"
17	NC01-93-0010	7	LOCK NUT ZINC 5/16-18
18	81-57-0250	1	RUBBER REINFORCEMENT
19	NC01-17-0396	6	HEX. BOLT GR2 ZINC 5/8-11 X 2"
20	NC02-07-0022	6	HEX. NUT ZINC 5/8-11

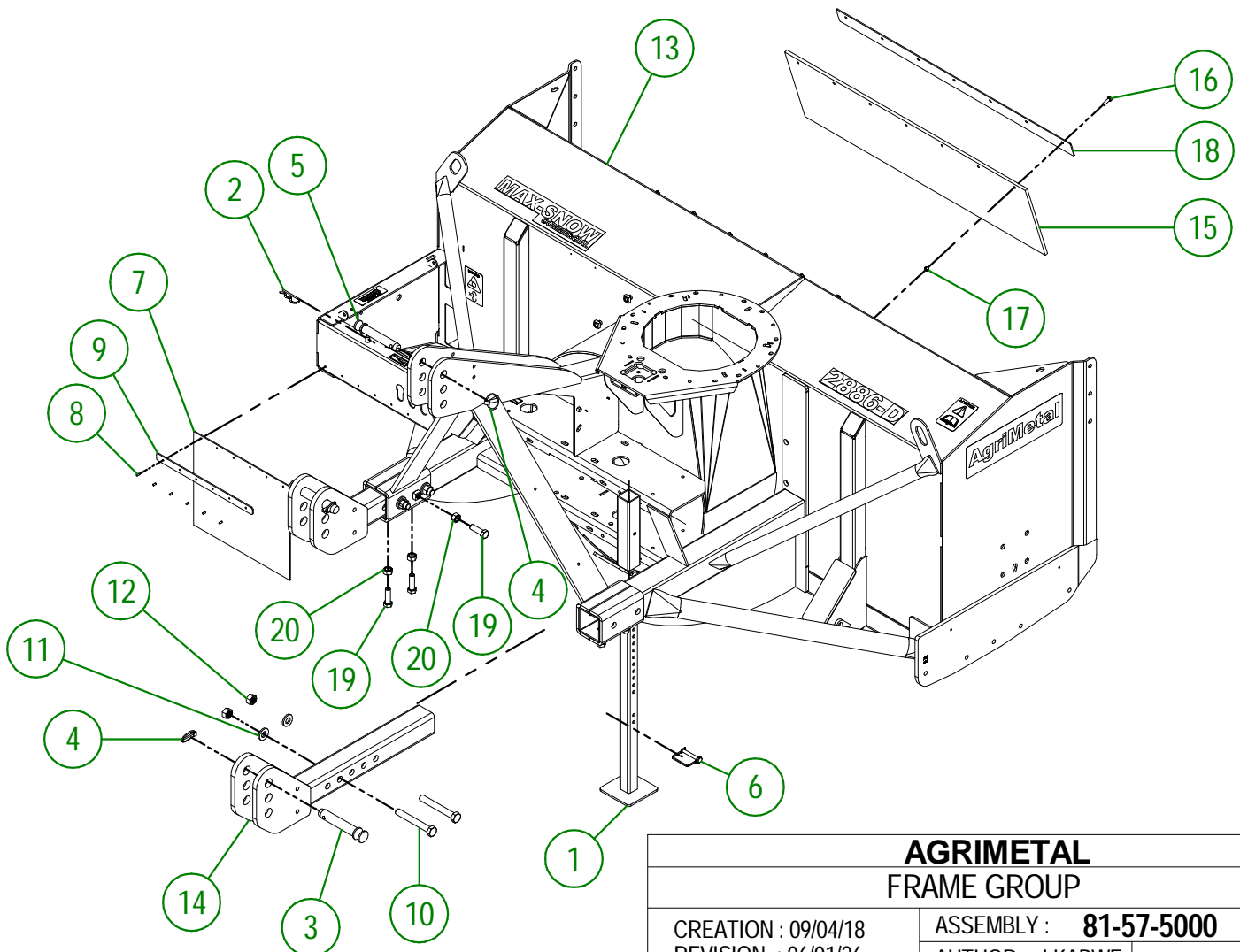

AGRIMETAL
FRAME GROUP

CREATION : 09/04/18
REVISION : 06/01/26

ASSEMBLY : **81-57-5000**
AUTHOR : J.KABWE

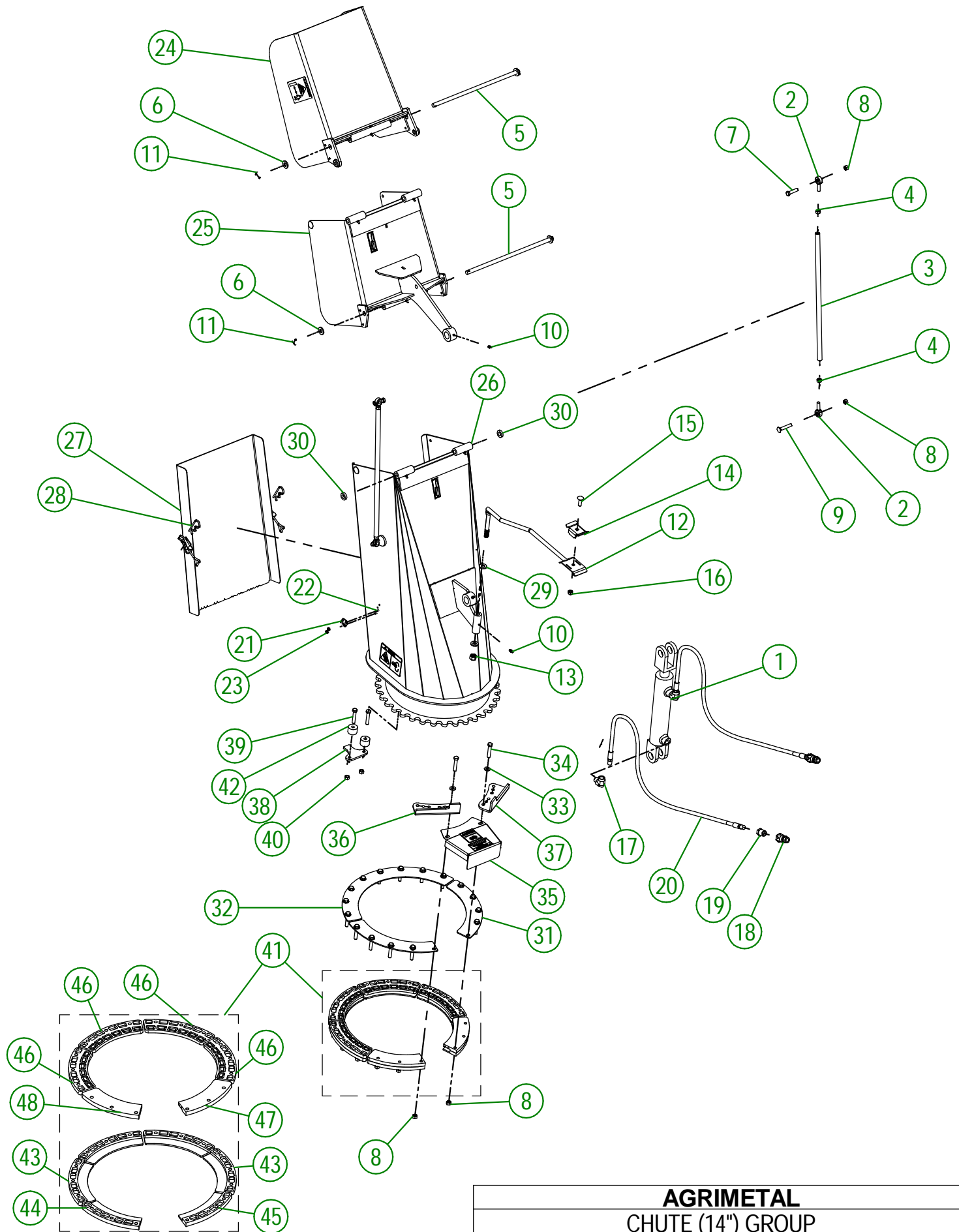

AGRIMETAL
CHUTE (14'') GROUP

CREATION : 12/04/19
 REVISION : 22/12/25

ASSEMBLY : **81-57-0331**
 AUTHOR : dessin3

81-57-0331

#	PART#	QTY	TITLE
1	NC13-45-0404	1	HYDRAULIC CYLINDER 6"
2	NC01-67-0304	4	ROD END 3/8-24
3	48-13-0600	2	CHUTE ROD (DOUBLE)
4	NC02-10-0018	4	NUT 3/8-24
5	81-20-0250	2	PIVOT
6	NC02-25-0011	4	WASHER SAE ZINC 17/32 ID
7	NC01-25-0116	2	HEX. BOLT GR5 ZINC 3/8-16 X 1 1/2"
8	NC01-93-0011	22	LOCK NUT 3/8-16
9	NC01-07-0113	2	CARR. BOLT GR5 ZINC 3/8-16 X 2" LG
10	NC01-69-0785	9	STRAIGHT GREASE FITTING 1/4-28
11	NC01-69-0139	4	COTTER PIN ZINC 1/8" X 3/4"
12	48-50-1030	1	HYDRAULIC HOSE SUPPORT
13	NC01-96-0014	1	NYLON-INSERT LOCKNUT ZINC 1/2-13
14	48-01-7530	1	HYDRAULIC HOSE SUPPORT
15	NC01-04-0110	1	CARR. BOLT GR2 ZINC 3/8-16 X 1 1/4"
16	NC01-96-0011	1	NYLON NUT 3/8-16
17	NC13-45-0038	2	ELBOW 90 3/8 FEM. NPT X 3/8 MALE NPT
18	NC13-45-0369	2	QUICK COUPLER 1/2-14 NPTF
19	NC13-45-0153	2	HEX. REDUCER 1/4 NPT X 1/2 NPT
20	NC17-02-0347	2	HYDRAULIC HOSE (111" LG)
21	NC01-63-0052	2	ADJUSTABLE LATCH (STRIKE)
22	NC02-40-0080	4	MACHINE SCREWS SQUARE SOCKET #10-24 X 1/2" LG
23	NC01-96-0006	4	NYLON NUT ZINC 3/16
24	81-57-0321	1	CHUTE (TOP SECTION)
25	81-57-0311	1	CHUTE (MIDDLE SECTION)
26	81-57-0302	1	CHUTE (BOTTOM SECTION)
27	81-57-0353	1	CHUTE DOOR
28	NC01-63-0026	2	COTTER PIN ZC 5/32" X 3"
29	NC02-25-0011	2	WASHER SAE ZINC 17/32 ID
30	NC13-15-0334	2	PIVOT WASHER
31	48-01-1165	2	BRACE
32	48-01-1167	1	BRACE
33	NC02-26-1525	18	WASHER INOX .406" D.I. X .815" D.E.
34	NC01-17-0118	18	HEX. BOLT GR2 ZINC 3/8-16 X 2"
35	80-57-0550	1	SPROCKET GUARD GROUP "STICKER INCLUDED"
36	81-04-0175	1	ADJUSTABLE STOPPER
37	81-04-0177	1	ADJUSTABLE STOPPER
38	84-04-0170	1	STOPPER
39	NC01-37-0118	2	HEX. BOLT GR8 ZINC 3/8-24 X 2"
40	NC01-94-0011	2	LOCK NUT 3/8-24
41	81-57-0550	1	CHUTE GUIDE GROUP
42	81-21-0040	2	ADJUSTABLE STOPPER SPACER

81-57-0550

#	PART#	QTY	TITLE
43	NC17-46-0025	4	CHUTE GUIDE (UNDER)
44	48-42-0305	1	CHUTE GUIDE (UNDER)
45	48-42-0310	1	CHUTE GUIDE (UNDER)
46	NC17-46-0026	4	CHUTE GUIDE (TOP)
47	48-42-0320	1	CHUTE GUIDE (TOP)
48	48-42-0315	1	CHUTE GUIDE (TOP)

#	PART #	Qty	TITLE
1	48-01-7527	1	HYDRAULIC HOSE SUPPORT
2	48-50-1025	1	HYDRAULIC ENGINE SPROCKET
3	80-13-0100	2	HYDRAULIC RESTRICTOR
4	80-45-0000	2	HEX. REDUCER 1/4 NPT X 1/2 NPT
5	81-01-7600	1	HYDRAULIC HOSE SUPPORT
6	NC01-04-0111	1	CARR. BOLT GR2 ZINC 3/8-16 X 1 1/2"
7	NC01-17-0115	2	HEX. BOLT GR2 ZINC 3/8-16 X 1 1/4"
8	NC01-33-0113	4	HEX.BOLT GR8 ZINC 3/8-16 X 3/4"
9	NC01-45-0184	1	HEX. BOLT GR8.8 ZINC 8MM X 20MM
10	NC01-96-0011	1	NYLON NUT 3/8-16
11	NC02-07-0018	2	HEX. NUT ZINC 3/8-16
12	NC02-26-0504	1	WASHER
13	NC02-26-1525	2	WASHER INOX .406" D.I. X .815" D.E.
14	NC02-32-0011	1	LOCK WASHER ZINC 5/16"
15	NC02-32-0012	6	LOCK WASHER ZINC 3/8"
16	NC02-44-0103	2	SET SCREW 5/16-18 X 3/8"
17	NC13-45-0367	2	45°-7/8-14 MALE O RING X 1/2 FEM.TOUR.NPT PT
18	NC13-45-0369	2	QUICK COUPLER 1/2-14 NPTF
19	NC13-45-0378	2	HYDRAULIC RESTRICTOR BUSHING
20	NC14-45-0156	1	HYDRAULIC MOTOR
21	NC17-02-0406	2	HYDRAULIC HOSE (87" LG)
22	NC17-46-0031	1	HYDRAULIC MOTOR BUSHING

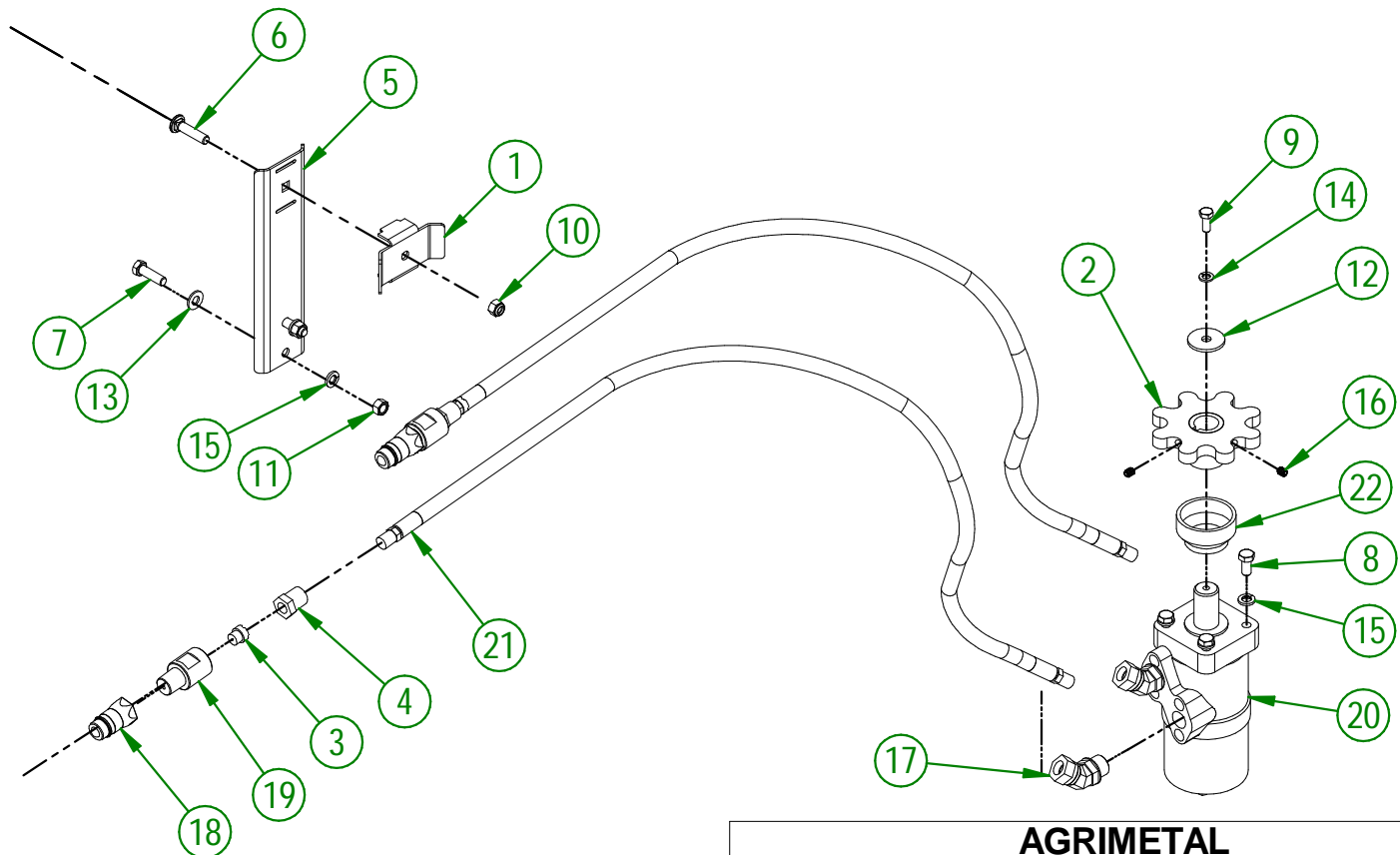

AGRIMETAL
HYDRAULIC MOTOR GROUP

CREATION : 05/12/17
REVISION : 25/03/26

ASSEMBLY : **81-57-5045**
AUTHOR : F.HÉLIE

#	PART #	Qty	TITLE
1	80-55-0010	1	GEARBOX
2	NC02-25-0011	14	WASHER SAE ZINC 17/32 ID
3	NC02-32-0014	12	LOCK WASHER ZINC 1/2"
4	NC01-33-0253	4	HEX. BOLT GR8 ZINC 1/2-13 X 2 1/2"
5	NC01-33-0248	4	HEX. BOLT .GR8 NC ZINC 1/2-13 X 1 1/4"
6	81-21-0005	4	TRANSMISSION BUSHING
7	80-41-0135	1	PTO GUARD STEEL CABLE
8	NC01-64-0005	2	OVAL SLEEVE (ALUMINUM)
9	80-41-0900	1	IMPELLER KEY
10	NC13-25-0019	1	BLACK TIE RAP
11	NC13-50-0110	1	IMPORTANT/NOTICE PTO POSTER
12	81-57-0040	1	PTO GUARD
13	81-34-0035	1	PTO SHAFT T80
14	NC01-63-0027	1	HAIRPIN COTTER
15	80-04-0485	1	GEARBOX BRACE
16	80-04-0480	1	GEARBOX BRACE
17	81-01-0921	1	PTO GUARD SUPPORT
18	NC01-33-0249	4	CAP SCREW GR8 NC ZINC 1/2-13 X 1 1/2" LG
19	NC02-07-0020	4	HEX. NUT ZINC 1/2-13

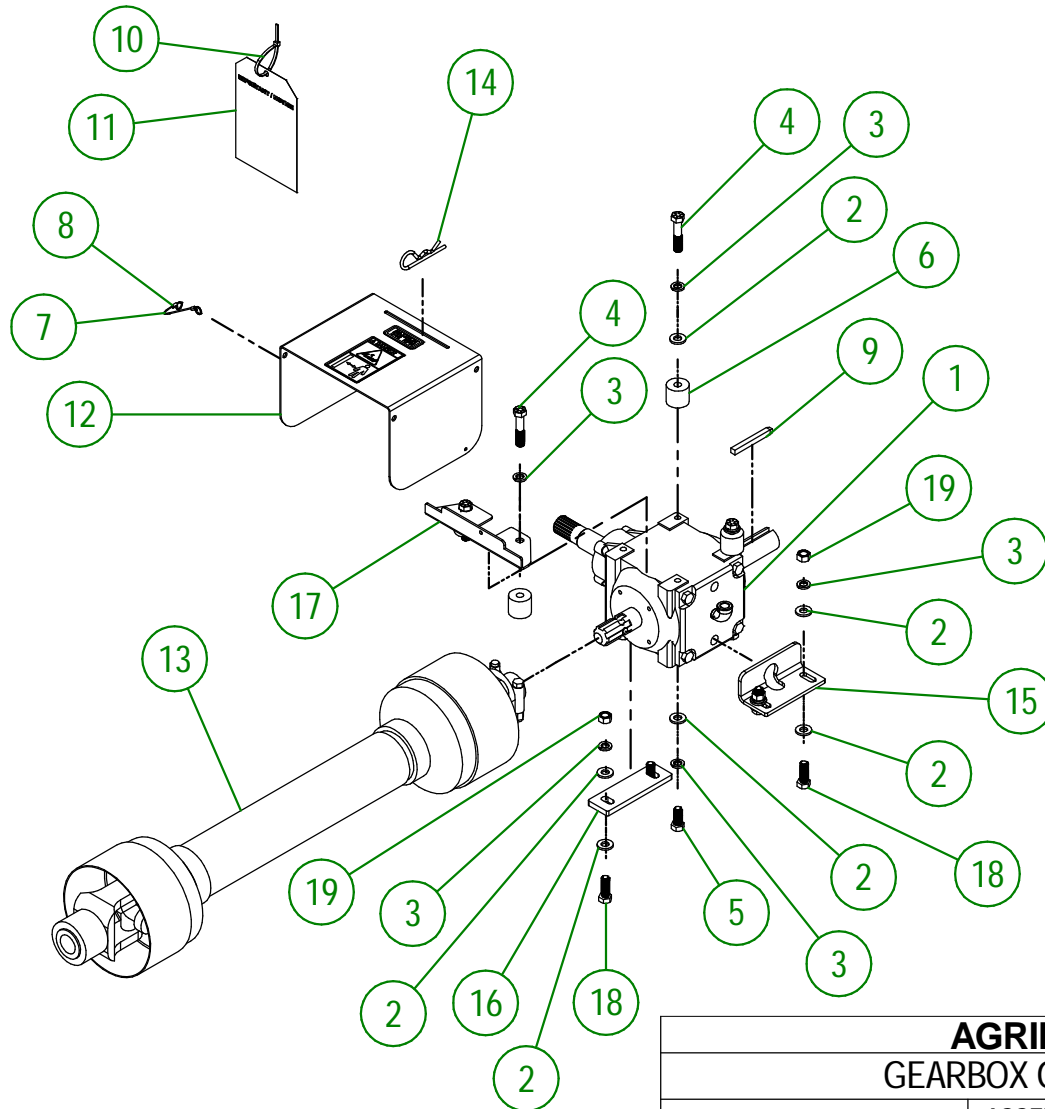

AGRIMETAL	
GEARBOX GROUPING	
CREATION : 19/07/16	ASSEMBLY : 81-57-0430
REVISION : 02/03/22	AUTHOR : Dessin2

#	PART #	Qty	TITLE
1	81-50-0050	1	IMPELLER
2	NC02-32-0016	1	LOCK WASHER ZINC 5/8"
3	NC01-25-0395	1	HEX. BOLT GR5 ZINC 5/8-11 X 1 3/4" LG
4	80-04-0185	1	WASHER
5	NC01-37-0255	2	HEX BOLT GR8 1/2" X 3" LG.
6	NC01-94-0013	2	NYLON NUT ZINC 1/2-20"
7	NC01-69-0791	1	GREASE FITTING 1/8 NPT STRAIGHT

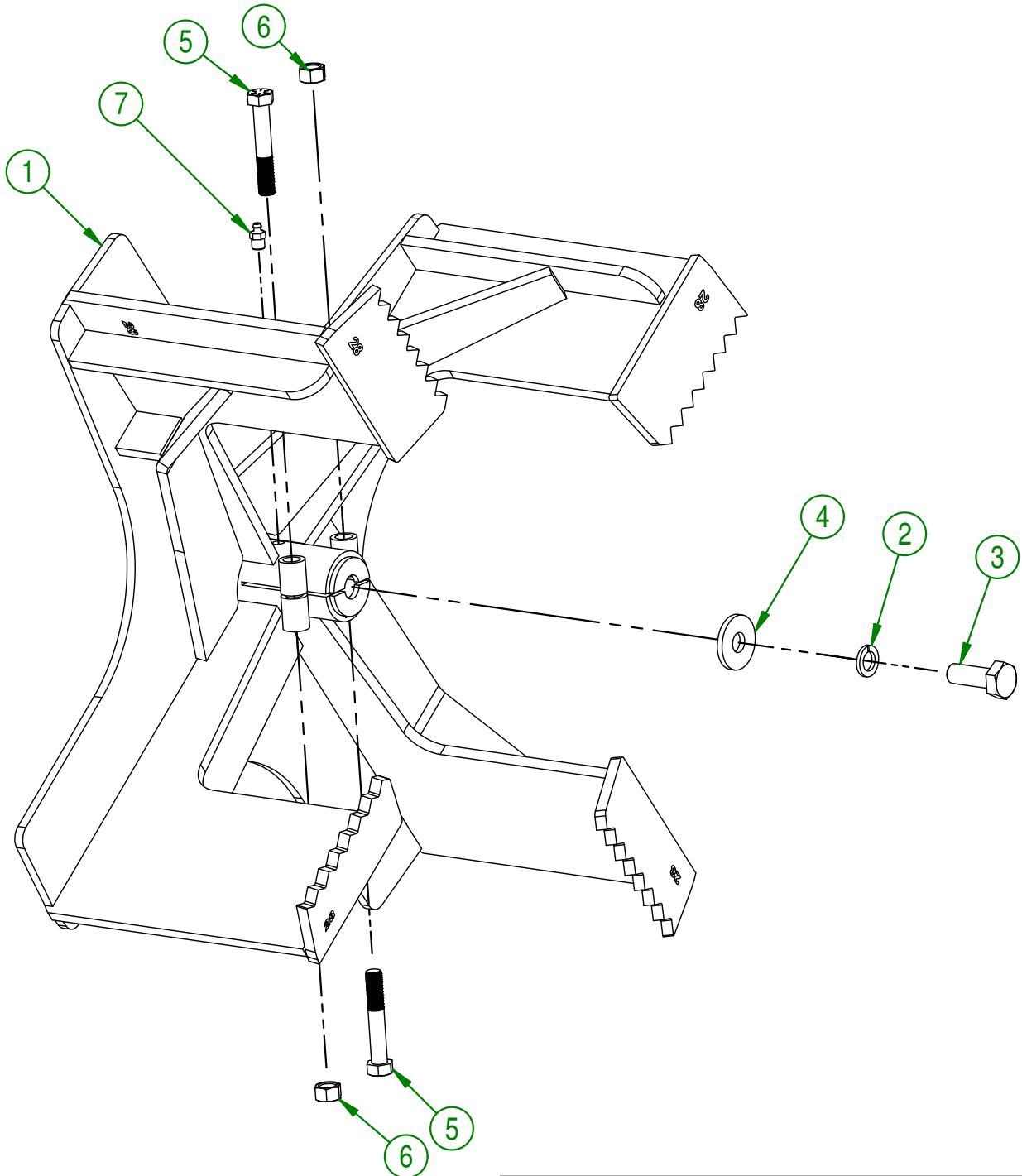

AGRIMETAL
IMPELLER GROUP

CREATION : 16/04/18
 REVISION : 26/02/19

ASSEMBLY : **81-57-0426**

AUTHOR : F.HÉLIE | Page 13 de 22

81-57-5035

#	PART #	Qty	TITLE
1	81-50-5015	1	LEFT SNOW GUARD
2	NC02-32-0014	6	LOCK WASHER ZINC 1/2"
3	NC01-25-0249	6	HEX. BOLT GR5 ZINC 1/2-13 X 1 1/2" LG
4	81-50-5020	1	RIGHT SNOW GUARD

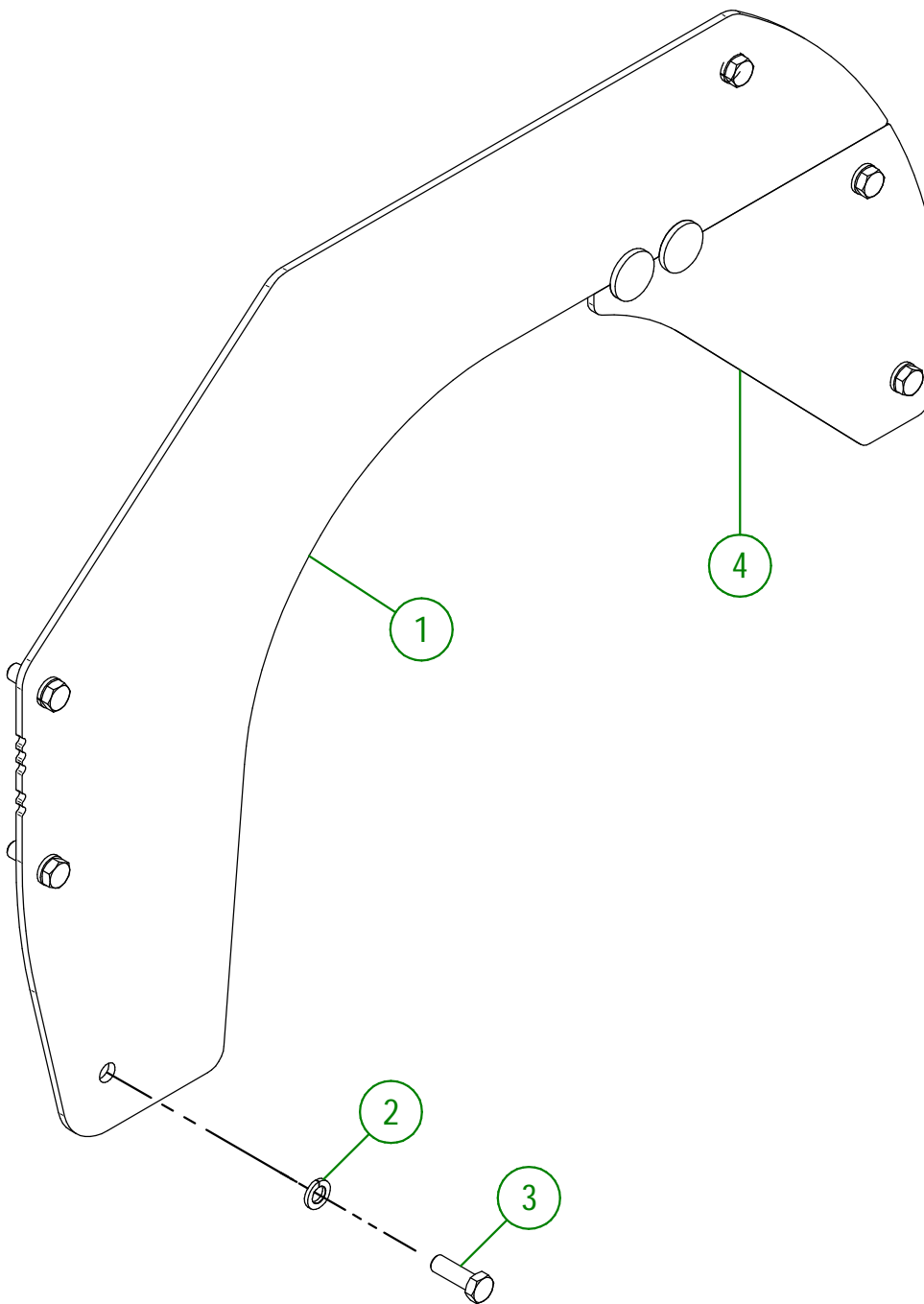

AGRIMETAL	
SNOW GUARD GROUP	
CREATION : 06/04/18	ASSEMBLY : 81-57-5035
REVISION : 29/09/22	AUTHOR : J.KABWE

#	PART #	Qty	TITLE
1	NC14-75-0161	2	FLANGE BEARING UCF 208-24 1 1/2" ID
2	81-50-5030	1	SPIRAL
3	NC02-32-0016	8	LOCK WASHER ZINC 5/8"
4	NC02-07-0022	8	HEX. NUT ZINC 5/8-11
5	NC02-25-0013	8	WASHER ZINC SAE ZINC 21/32 ID
6	NC01-17-0396	4	HEX. BOLT GR2 ZINC 5/8-11 X 2"
7	NC01-17-0395	4	HEX. BOLT GR2 ZINC 5/8-11 X 1 3/4"
8	NC14-55-0275	1	SPROCKET 80A34 X 1 1/2"
9	NC01-29-0249	4	HEX. BOLT GR2 NC ZINC 1/2-20 X 1 1/2"
10	NC01-94-0013	4	HEX. LOCK NUT NF ZINC 1/2-20
11	81-51-0086	1	SHAFT OF THE SPIRAL
12	81-51-0091	1	SHAFT OF THE SPIRAL (SPROCKET)

REBUILT KIT

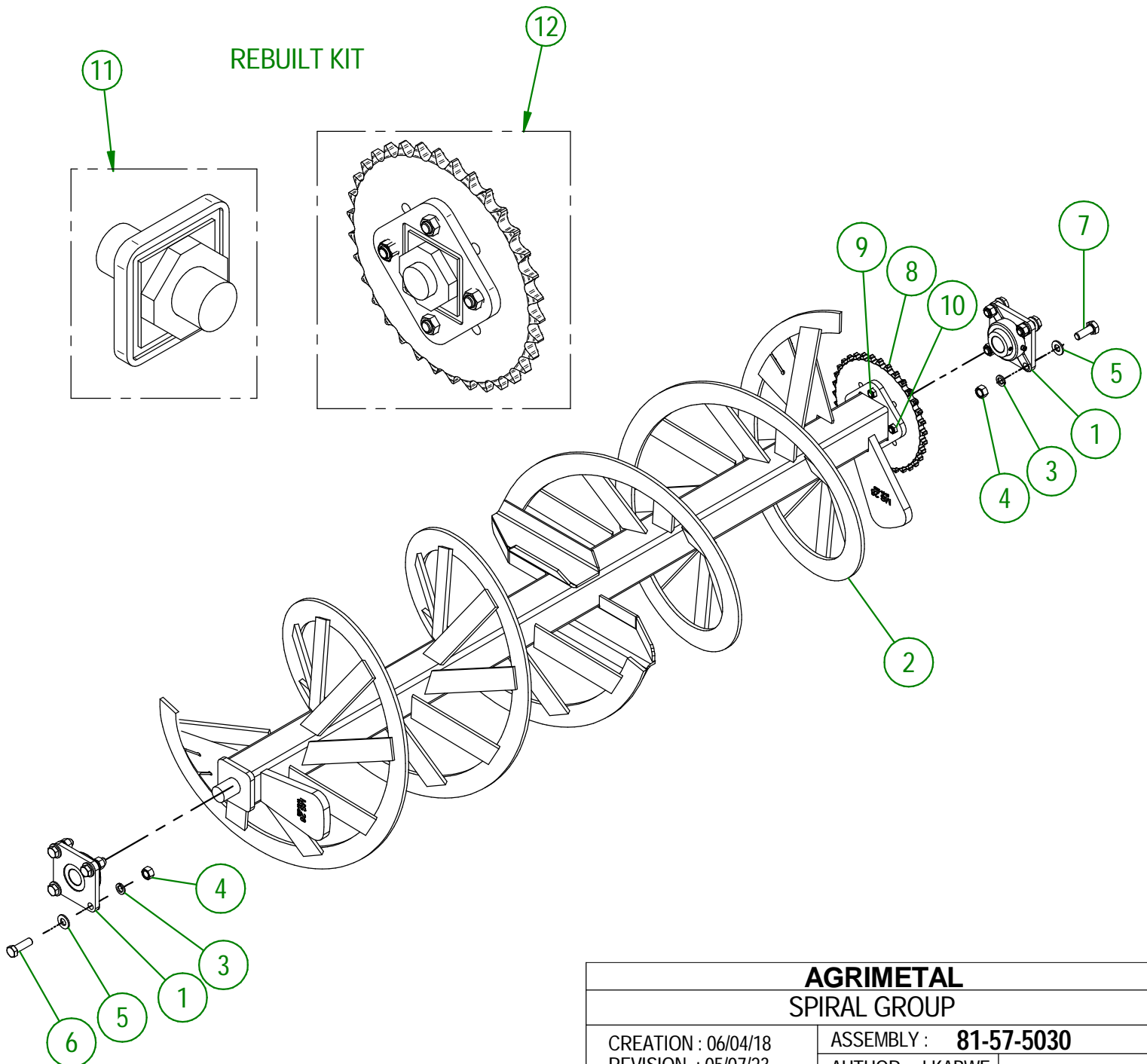

AGRIMETAL
SPIRAL GROUP

CREATION : 06/04/18
REVISION : 05/07/23

ASSEMBLY : **81-57-5030**
AUTHOR : J.KABWE

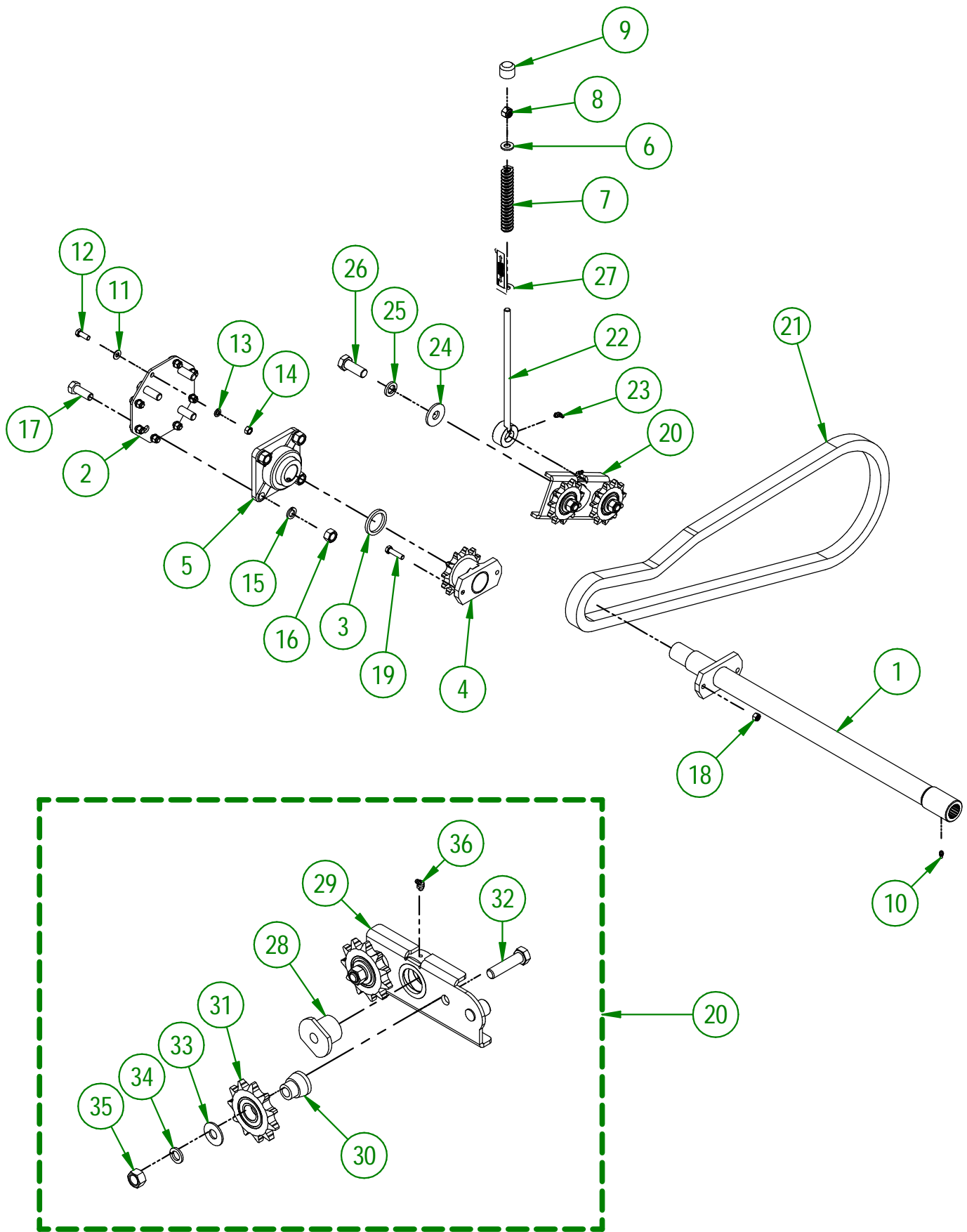

AGRIMETAL	
SPIRAL DRIVE TRAIN GROUP	
CREATION : 09/04/18	ASSEMBLY : 81-57-5005
REVISION : 22/12/25	AUTHOR : J.KABWE

#	PART #	Qty	TITLE
1	81-50-0065	1	SPIRAL DRIVE TRAIN
2	81-04-0010	1	BEARING SUPPORT
3	81-21-0010	1	SPIRAL DRIVE TRAIN BUSHING
4	NC14-55-0276	1	80B12H SPROCKET
5	NC14-75-0025	1	FLANGE BEARING 4 HOLES UCF 208-24 X 1 1/2"
6	NC02-25-0011	1	WASHER SAE ZINC 17/32 ID
7	NC13-86-0054	1	BLUE SPRING 1/2" ID X 1" OD X 6" LG
8	NC01-96-0014	1	NYLON-INSERT LOCKNUT ZINC 1/2-13
9	80-42-0110	1	THREADED ROD CAP
10	NC01-69-0785	1	STRAIGHT GREASE FITTING 1/4-28
11	NC02-26-1525	8	WASHER INOX .406" D.I. X .815" D.E.
12	NC01-17-0114	8	HEX. BOLT GR2 ZINC 3/8-16 X 1"
13	NC02-32-0012	8	LOCK WASHER ZINC 3/8"
14	NC02-07-0018	8	HEX. NUT ZINC 3/8-16
15	NC02-32-0016	4	LOCK WASHER ZINC 5/8"
16	NC02-07-0022	4	HEX. NUT ZINC 5/8-11
17	NC01-17-0395	4	HEX. BOLT GR2 ZINC 5/8-11 X 1 3/4"
18	NC01-93-0011	1	LOCK NUT 3/8-16
19	NC01-25-0116	1	HEX. BOLT GR5 ZINC 3/8-16 X 1 1/2"
20	81-55-0400	1	CHAIN TENSIONER GROUP
21	81-37-1005	1	#80 HD CHAIN
22	81-50-5035	1	CHAIN TENSIONER THREADED ROD
23	NC01-69-0787	1	GREASE FITTING STRAIGHT 1/4-28 X 90
24	81-04-0135	1	WASHER 2.015" DIA. X 49/64"
25	NC02-32-0017	1	LOCK WASHER ZINC 3/4"
26	NC01-25-0467	1	HEX. BOLT GR2 ZINC 3/4-10 X 2 " LG.
27	81-57-0160	1	ADJUSTEMENT INDICATOR

#	PART #	Qty	TITLE
28	88-13-0005	1	CHAIN TENSIONER BUSHING
29	81-50-5005	1	CHAIN TENSIONER
30	81-21-0020	2	CHAIN TENSIONER BUSHING
31	81-55-0005	2	CHAIN TENSIONER SPROCKET
32	NC01-17-0398	2	HEX. BOLT GR2 NC ZINC 5/8-11 X 2 1/2"
33	NC02-22-0013	2	WASHER ZINC 5/8 ID X 1 1/2 OD
34	NC02-32-0016	2	LOCK WASHER ZINC 5/8"
35	NC02-10-0022	2	HEX. NUT ZINC 5/8-18
36	NC01-69-0786	1	GREASE FITTING 1/4-28 X 45

AGRIMETAL	
SPIRAL DRIVE TRAIN GROUP	
CREATION : 09/04/18	ASSEMBLY : 81-57-5005
REVISION : 22/12/25	AUTHOR : J.KABWE

#	PART #	Qty	TITLE
1	81-50-0070	1	CHAIN GUARD
2	NC01-04-0107	6	CARR. BOLT GR2 ZINC 3/8-16 X 3/4"
3	NC02-14-0019	6	FLANGE NUT HEX. NC 3/8-16 GR. B

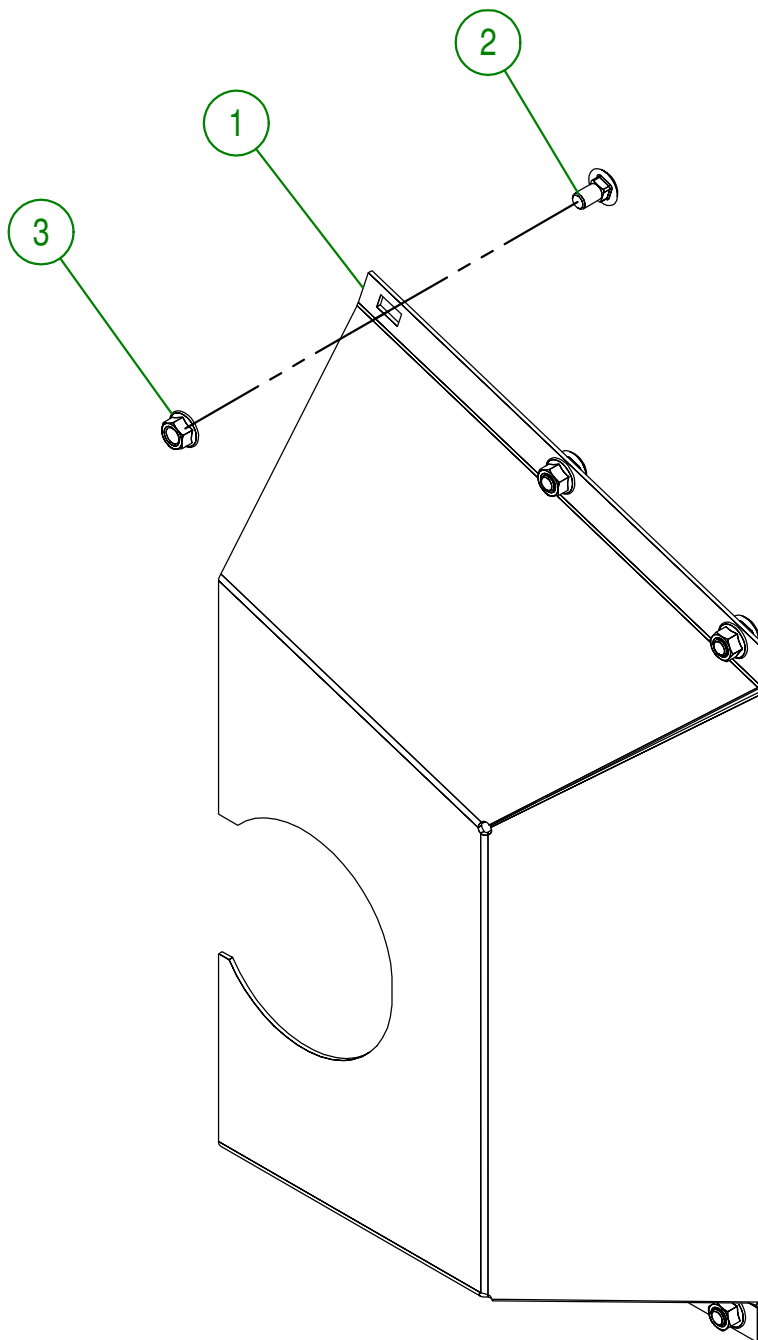

AGRIMETAL	
SPIRAL CHAIN GUARD GROUP	
CREATION : 19/07/16	ASSEMBLY : 81-57-0405
REVISION : 06/04/18	AUTHOR : J. HOULE Page 18 de 22

#	PART #	Qty	TITLE
1	81-57-5025	1	CHAIN GUARD
2	NC02-26-1525	4	WASHER INOX .406" D.I. X .815" D.E.
3	NC01-17-0114	2	HEX. BOLT GR2 ZINC 3/8-16 X 1"
4	NC01-96-0011	2	NYLON NUT 3/8-16

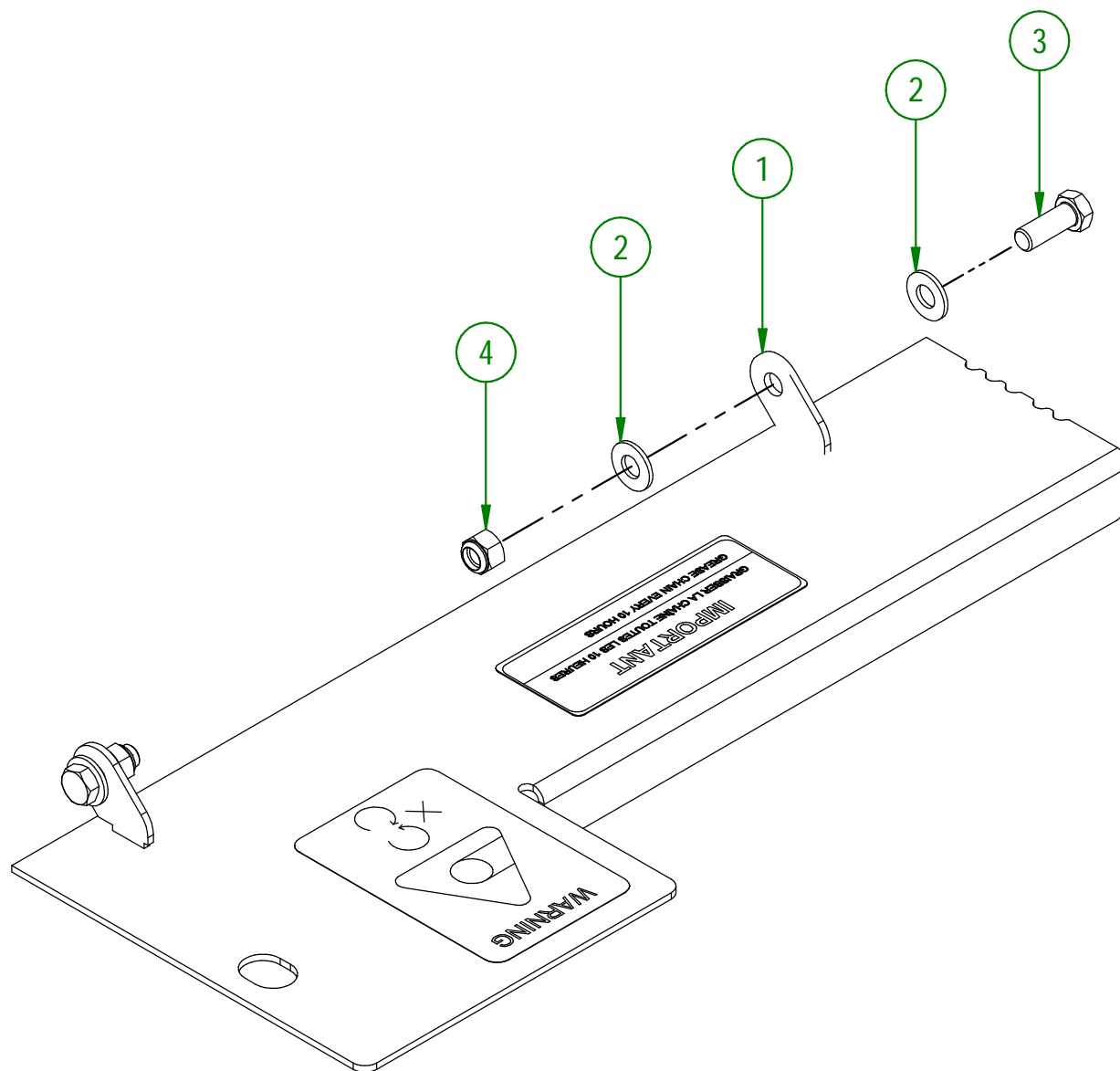

AGRIMETAL	
CHAIN GUARD GROUP	
CREATION : 09/04/18	ASSEMBLY : 81-57-5040
REVISION : 22/12/25	AUTHOR : J.KABWE

#	PART #	Qty	TITLE
1	NCI3-30-0237	1	PLASTIC TUBE FOR OPERATOR'S MANUAL
2	NC02-25-0007	2	WASHER ZINC 0.281 = 9/32
3	NC01-17-0007	2	HEX. BOLT GR2 ZINC 1/4-20 X 1 1/4"
4	NC01-96-0009	2	NYLON-INSERT LOCKNUT ZINC 1/4-20
5	81-57-0030	1	SET OF 6 SHEAR BOLT WITH NUT
6	81-98-0521	1	ENGLISH OPERATOR'S MANUAL (MS28 & 30)

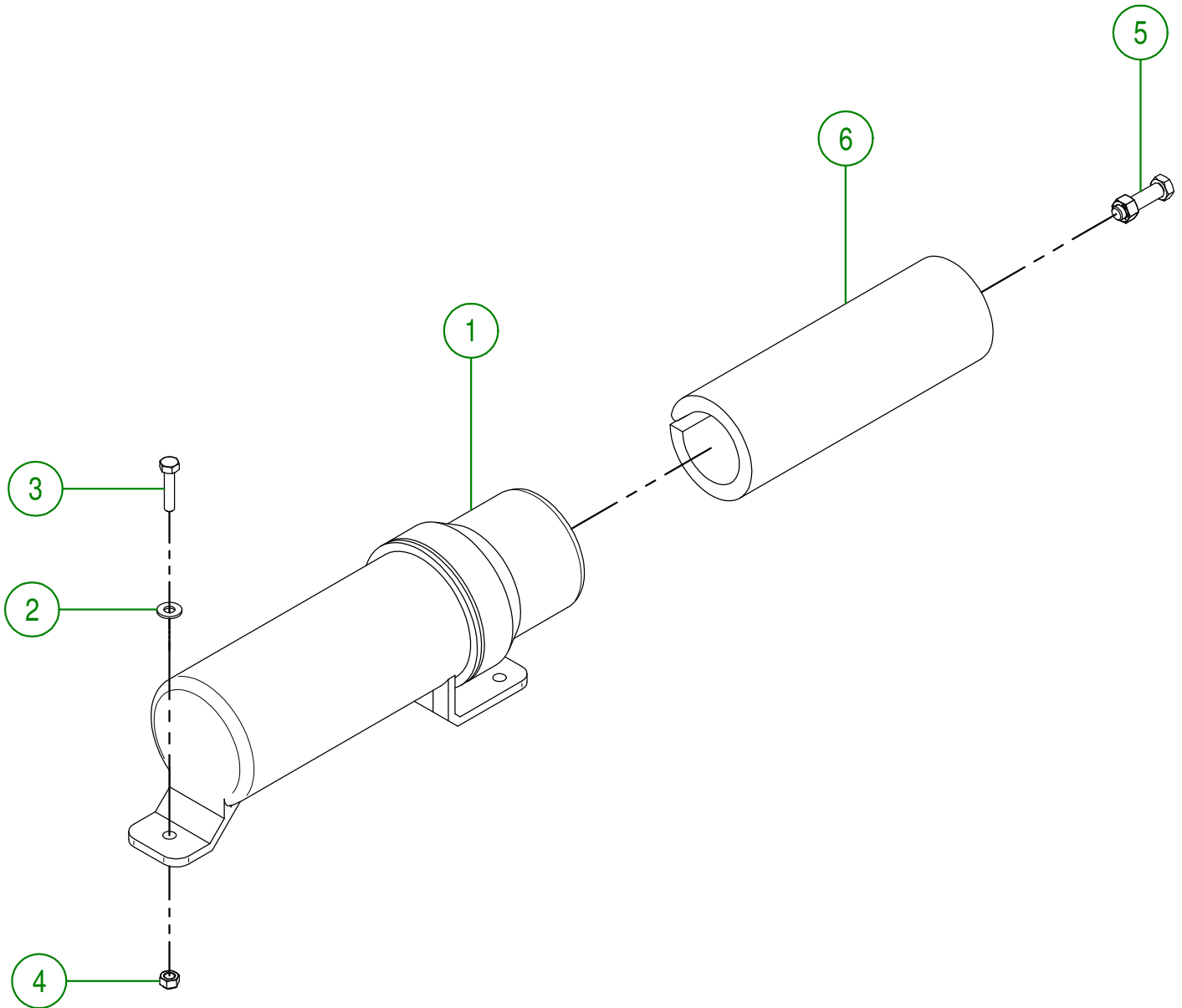

AGRIMETAL	
OPERATOR'S MANUAL TUBE GROUP	
CREATION : 19/07/16	ASSEMBLY : 81-57-0400
REVISION : 08/05/18	AUTHOR : J. HOULE Page 20 de 22

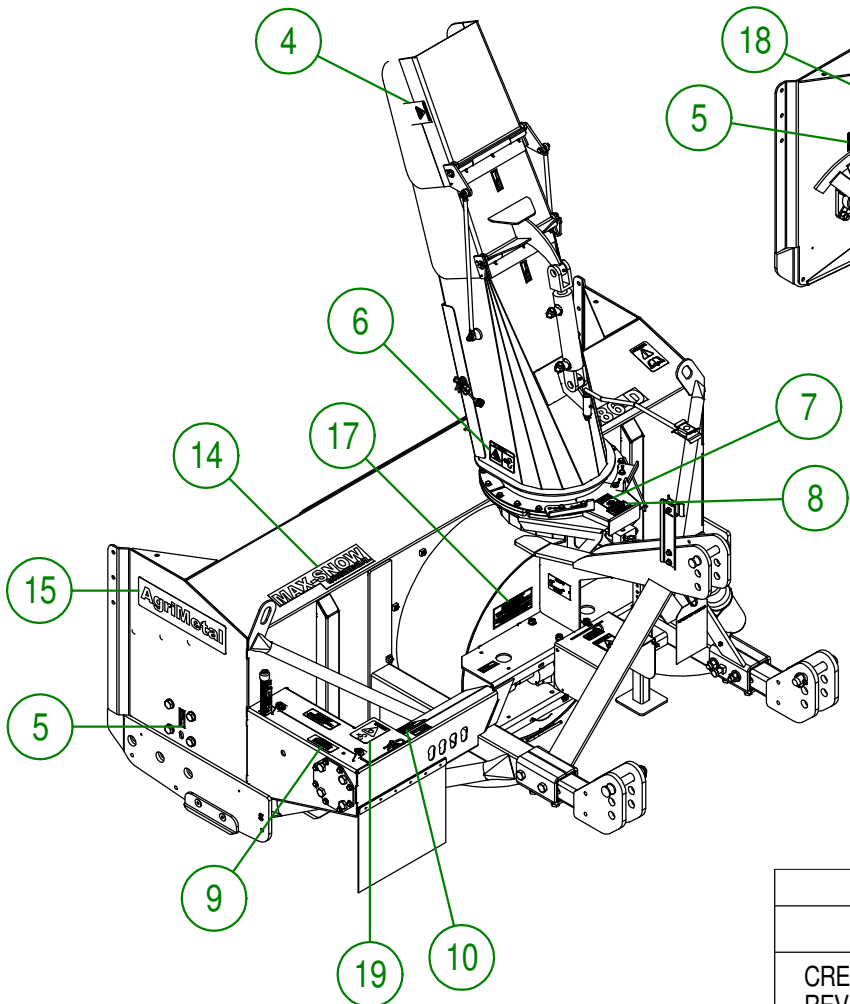
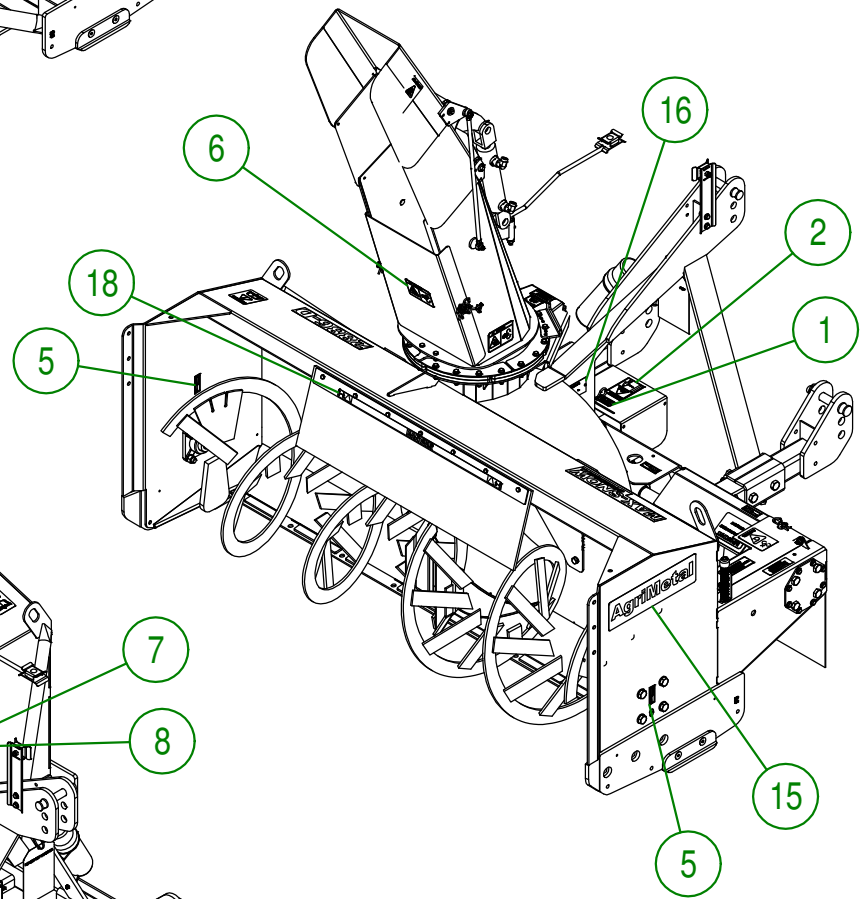
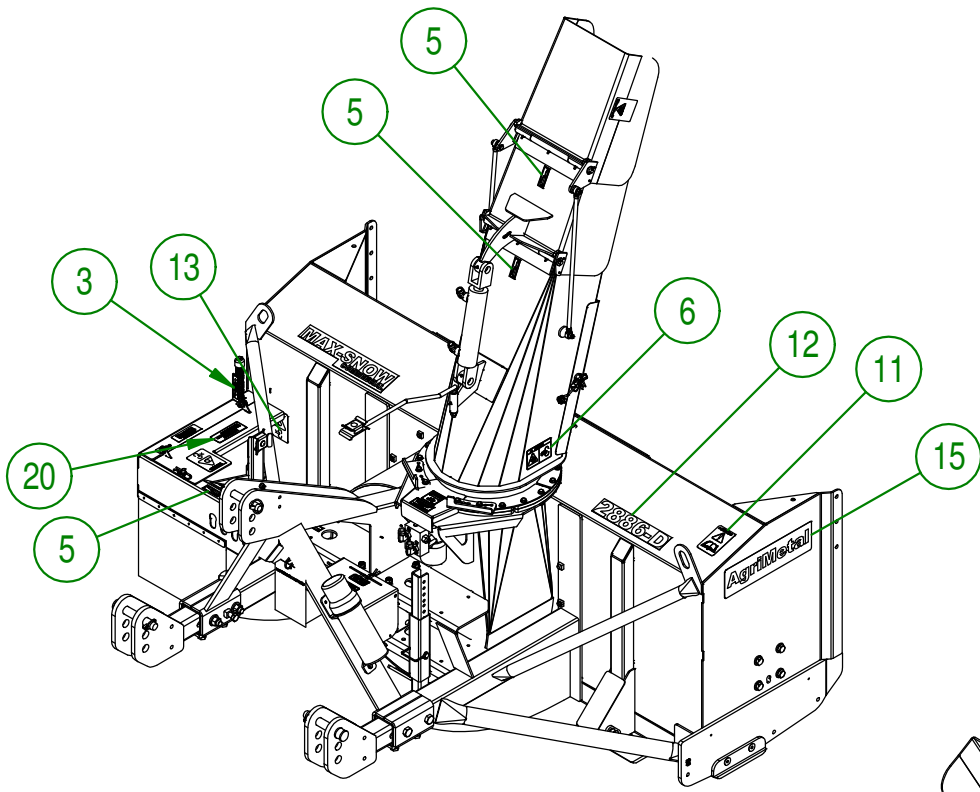

AGRIMETAL	
MS 2886-D	
CREATION : 06/04/18	ASSEMBLY : 81-99-1000
REVISION : 19/11/19	AUTHOR : J.KABWE Page 21 de 22

#	PART #	Qty	TITLE
1	NC13-33-0005	2	STICKER MAXIMUM 540 RPM
2	NC13-33-0187	2	STICKER DANGER (PTO AND PERSON)
3	NC13-33-0344	1	ADJUSTEMENT INDICATOR STICKER
4	NC13-33-0192	2	STICKER (PROJECTION RISK)
5	NC13-33-0024	6	STICKER GREASE HERE
6	NC13-33-0249	3	STICKER DANGER
7	NC13-33-0326	1	STICKER DANGER (HAND)
8	NC13-33-0327	1	STICKER END ROTATION ADJUSTMENT
9	NC13-33-0248	1	STICKER IMPORTANT 4 1/4 INCHES 110mm
10	NC13-33-0281	1	STICKER SHEAR BOLT
11	NC13-33-0183	1	STICKER CAUTION OPERATION MANUAL
12	NC13-33-0313	1	STICKER 2886-D
13	NC13-33-0189	1	STICKER DANGER (PERSON AND CHAIN DRIVE)
14	NC13-33-0241	1	STICKER MAX-SNOW COMMERCIAL
15	NC13-33-0001	2	STICKER AGRIMETAL
16	NC13-50-0086	1	SERIAL NUMBER PLATE
17	NC13-33-0317	1	STICKER GREASE DRIVE LINE TELESCOPIC SHAFT
18	NC13-33-0274	1	STICKER DANGER
19	NC13-33-0283	1	STICKER DANGER (PERSON AND CHAIN DRIVE)
20	NC13-33-0343	1	GREASE CHAIN EVERY 10 HOURS STICKER

AGRIMETAL**MS 2886-D**

CREATION : 06/04/18
 REVISION : 19/11/19

ASSEMBLY : **81-99-1000**

AUTHOR : J.KABWE | Page 22 de 22