

AgriMetal

PARTS LIST

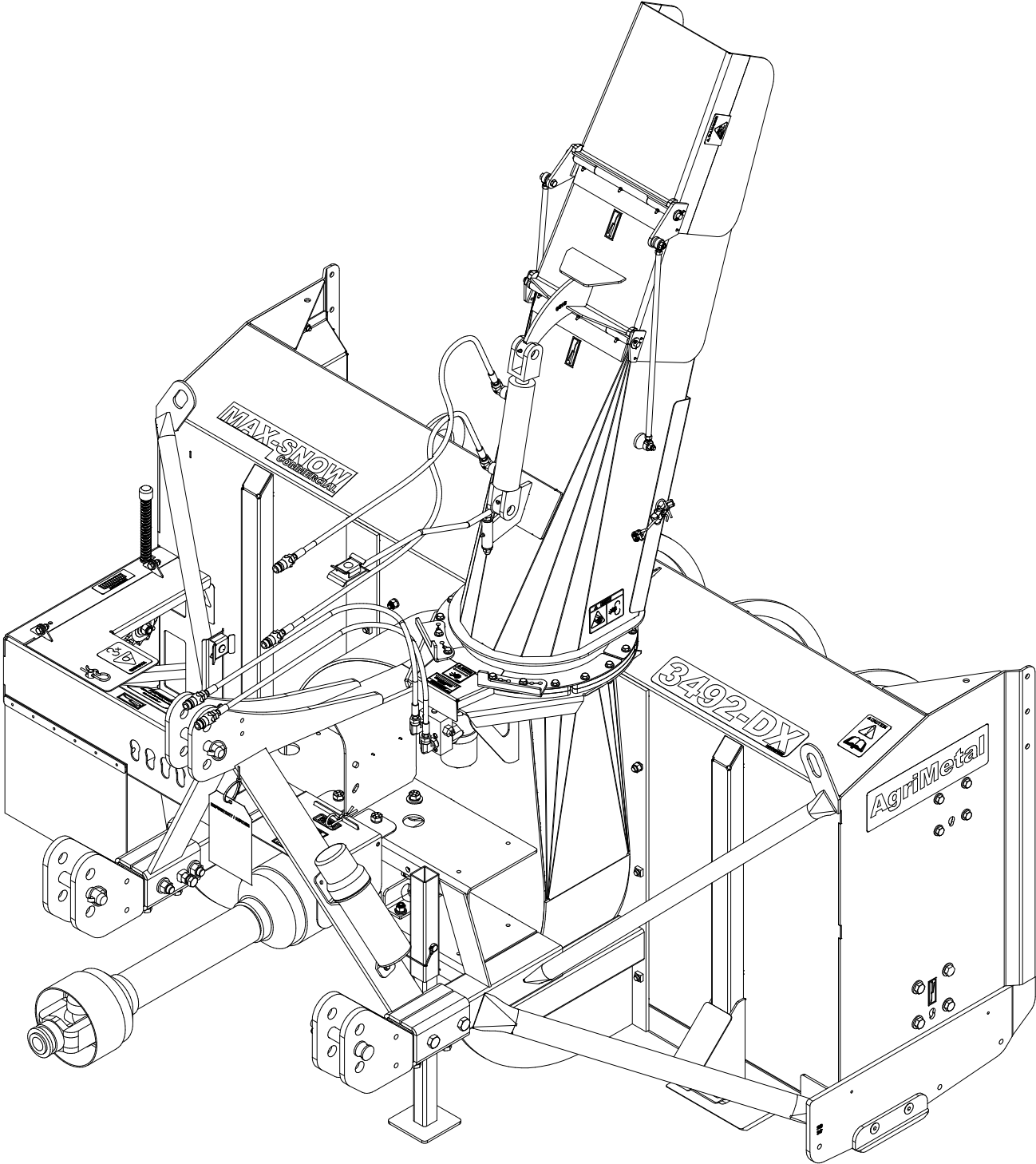

MS3492-DX

81-57-0700

#	PART #	Qty	TITLE
1	80-50-0085	2	LATERAL SKATE (#450 HARDNESS STEEL)
2	81-50-0055	2	ADJUSTABLE SKATE (#450 HARDNESS STEEL)
3	NC02-48-0586	4	FLAT HEAD SOCKET CAP SCREW 5/8-11 X 1" LG
4	81-57-0230	2	KNIFE (#450 HARDNESS STEEL) GROUP (BOLTS AND NUTS INCLUDED)
5	NC01-25-0481	2	HEX. BOLT GR5 NC 3/4-10 X 5"
6	NC01-96-0017	2	HEX. LOCK NUT NYLO. NC 3/4-10

81-57-0230

#	PART #	Qty	TITLE
7	NC01-93-0016	5	LOCK NUT ZINC 5/8-11
8	NC01-09-0039	5	PLOW BOLT GR5 5/8-11 X 1 1/2" LG

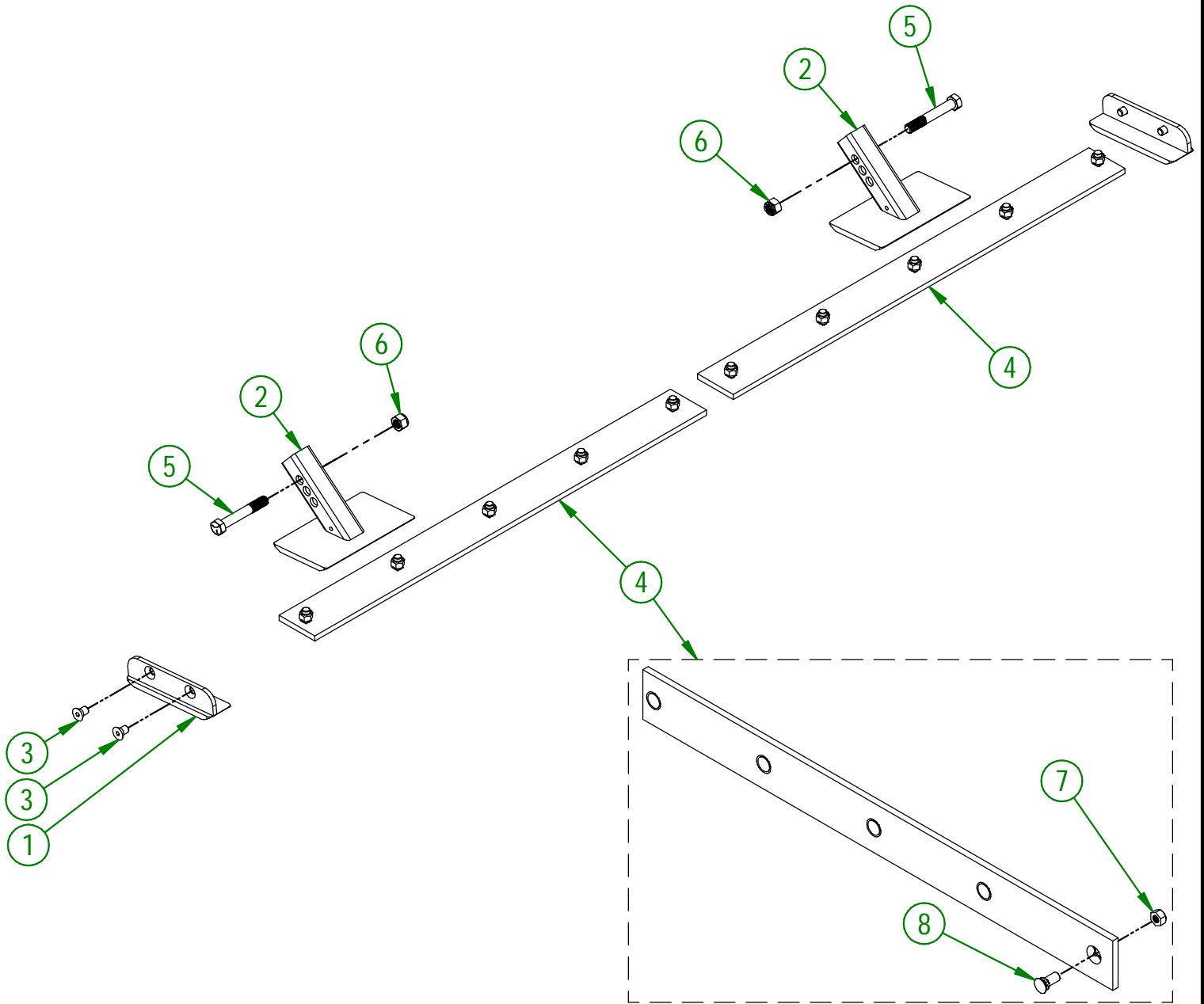

AGRIMETAL

SET OF KNIVES (#450 HARDNESS STEEL)

CREATION : 19/07/16
REVISION : 20/05/25

ASSEMBLY : **81-57-0700**
AUTHOR : Dessin2

81-57-0710

#	PART #	Qty	TITLE
1	NC02-48-0586	4	FLAT HEAD SOCKET CAP SCREW 5/8-11 X 1" LG
2	80-50-0087	2	LATERAL SKATE (STAINLESS STEEL)
3	81-50-0058	2	ADJUSTABLE SKATE (STAINLESS STEEL)
4	81-57-0235	2	KNIFE (STAINLESS STEEL) GROUP (BOLTS AND NUTS INCLUDED)
5	NC01-25-0481	2	HEX. BOLT GR5 NC 3/4-10 X 5"
6	NC01-96-0017	2	HEX. LOCK NUT NYLO. NC 3/4-10

81-57-0235

#	PART #	Qty	TITLE
5	NC02-48-0562	5	FLAT HEAD SOCKET CAP SCREW STAINLESS 5/8-11 X 1 1/2"
6	NC01-93-0016	5	LOCK NUT ZINC 5/8-11

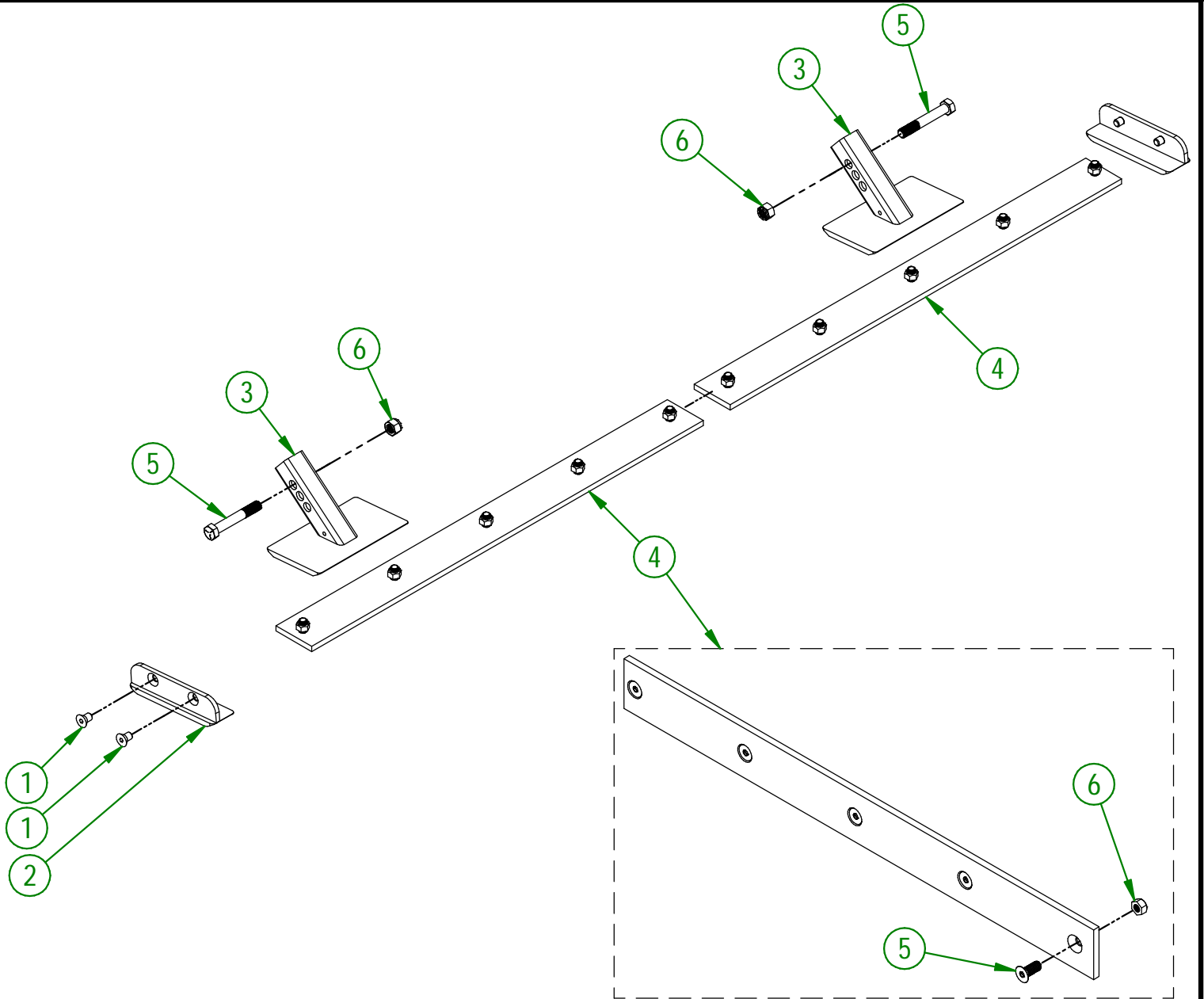

AGRIMETAL	
SET OF KNIVES (STAINLESS STEEL)	
CREATION : 19/07/16	ASSEMBLY : 81-57-0710
REVISION : 20/05/25	AUTHOR : Dessin2

81-57-0705

#	PART #	Qty	TITLE
1	81-50-0700	2	KNIFE BRACE (TOP)
2	81-42-0105	1	RIGHT KNIFE (UHMW)
3	81-42-0106	1	LEFT KNIFE (UHMW)
4	81-04-0350	2	KNIFE BRACE (UNDER)
5	NC02-48-0564	10	FLAT HEAD SOCKET CAP SCREW STAINLESS 5/8-11 X 2" LG
6	NC01-93-0016	10	LOCK NUT ZINC 5/8-11
7	81-42-0103	1	LATERAL KNIFE (RIGHT)
8	81-42-0104	1	LATERAL KNIFE (LEFT)
9	NC02-25-0011	4	WASHER SAE ZINC 17/32 ID
10	80-04-0185	6	WASHER
11	NC01-17-0394	6	HEX. BOLT GR2 ZINC 5/8-11 X 1 1/2"
12	NC01-17-0250	2	HEX. BOLT GR2 ZINC 1/2-13 X 1 3/4"
13	NC01-17-0251	2	HEX. BOLT GR2 ZINC 1/2-13 X 2"
14	NC01-93-0014	4	LOCK NUT ZINC 1/2-13

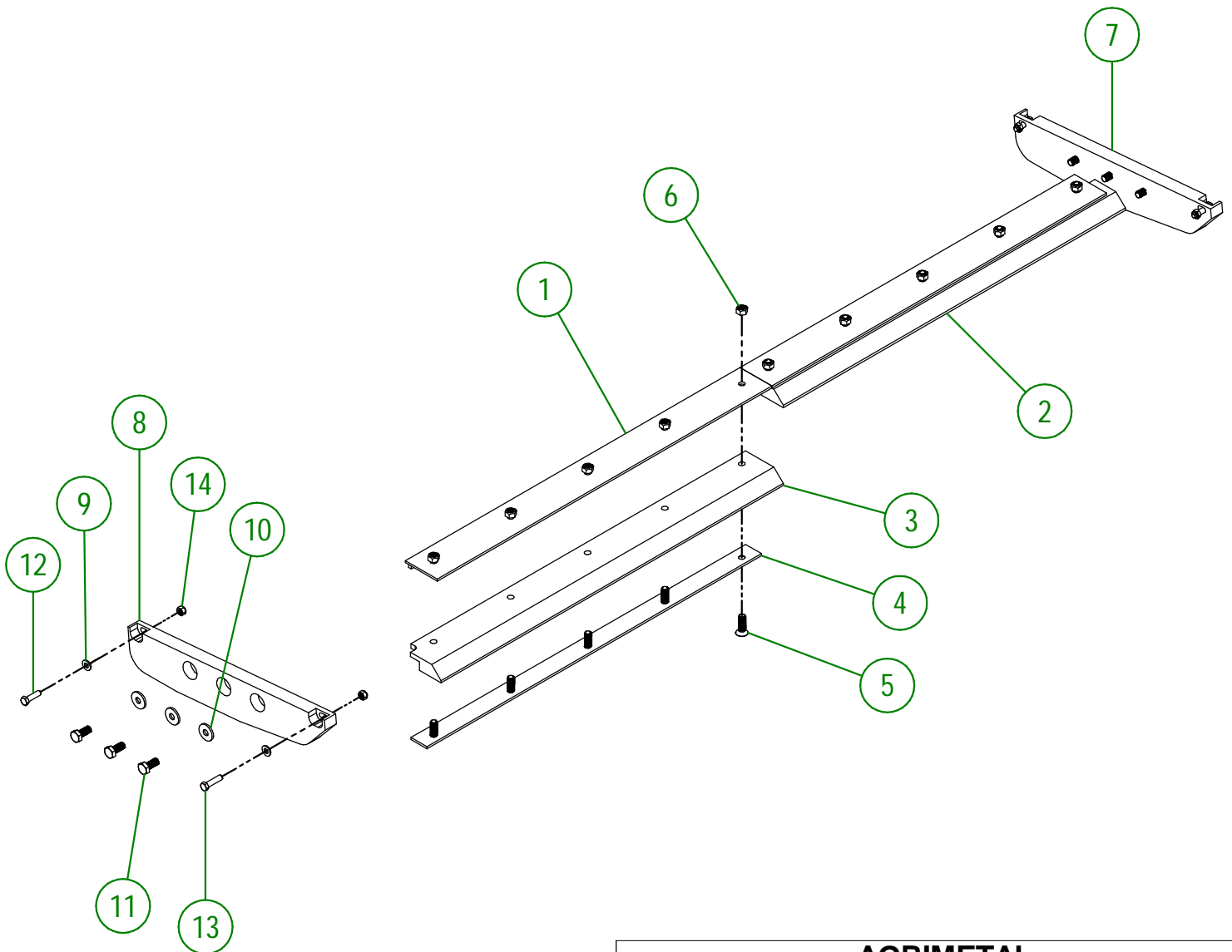

AGRIMETAL	
SET OF KNIVES (UHMW)	
CREATION : 19/07/16	ASSEMBLY : 81-57-0705
REVISION : 27/09/23	AUTHOR : J. HOULE

81-57-0215

#	PART #	Qty	TITLE
1	81-20-0337	1	LATERAL CUTTER BLADES (LEFT)
2	81-20-0335	1	LATERAL CUTTER BLADES (RIGHT)
3	81-10-0000	4	LATERAL CUTTER BLADES BUSHING
4	NC01-33-0248	10	HEX. BOLT .GR8 NC ZINC 1/2-13 X 1 1/4"
5	NC01-33-0514	4	HEX. BOLT GR8 ZINC 1/2-13 X 2 1/4"
6	NC02-32-0014	14	LOCK WASHER ZINC 1/2"
7	NC02-07-0020	14	HEX. NUT ZINC 1/2-13
8	81-04-0525	2	LATERAL KNIFE REINFORCE
9	NC02-22-0012	2	WASHER ZINC 1/2 BOLT = 9/16"Ø X 1 3/8" OD

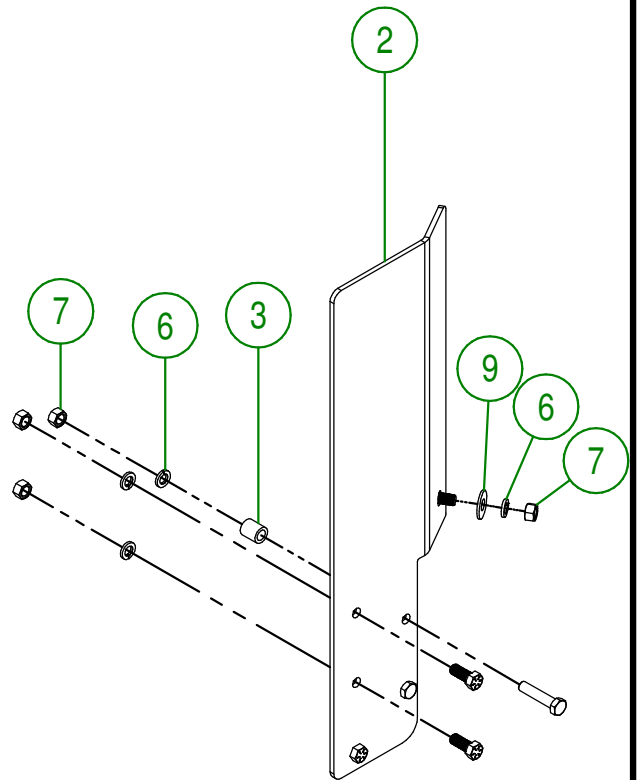
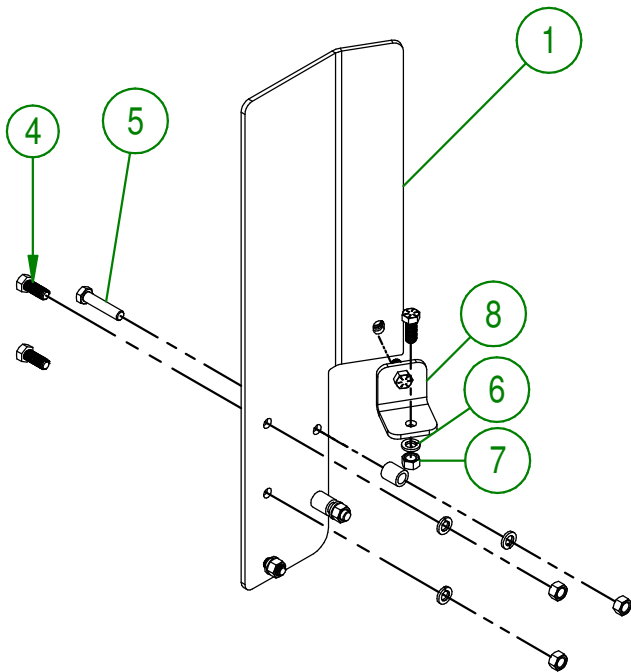

AGRIMETAL	
LATERAL CUTTER BLADES	
CREATION : 24/11/17	ASSEMBLY : 81-57-0215
REVISION : 06/12/21	AUTHOR : J. Houle

#	PART #	Qty	TITLE
1	83-50-5021	2	ATTACHMENT HAND
2	NC13-15-0300	1	SNOW GUARD
3	80-01-1075	1	SNOW GUARD BRACE
4	NC01-78-0041	6	POP RIVET STAINLESS STEEL ROD STEEL .187" X .690"
5	NC01-33-0481	4	HEX. BOLT GR8 ZINC 3/4-10 X 5 1/2"
6	22-04-6805	4	FLAT WASHER BEARING BASE
7	NC01-93-0017	4	HEX. LOCKNUT STEEL NC Z 3/4-10
8	48-20-0065	2	3 POINT PIN
9	48-20-0060	1	3 POINT PIN
10	NC01-69-1100	3	LINCH PIN 3/8"
11	NC01-63-0026	1	COTTER PIN ZC 5/32" X 3"
12	81-50-0090	1	STAND
13	NC01-69-1306	1	LOCKING PIN 3/8" X 2 1/2" LG
14	83-57-5056	1	FRAME
15	NC02-07-0022	6	HEX. NUT ZINC 5/8-11
16	NC01-17-0396	6	HEX. BOLT GR2 ZINC 5/8-11 X 2"

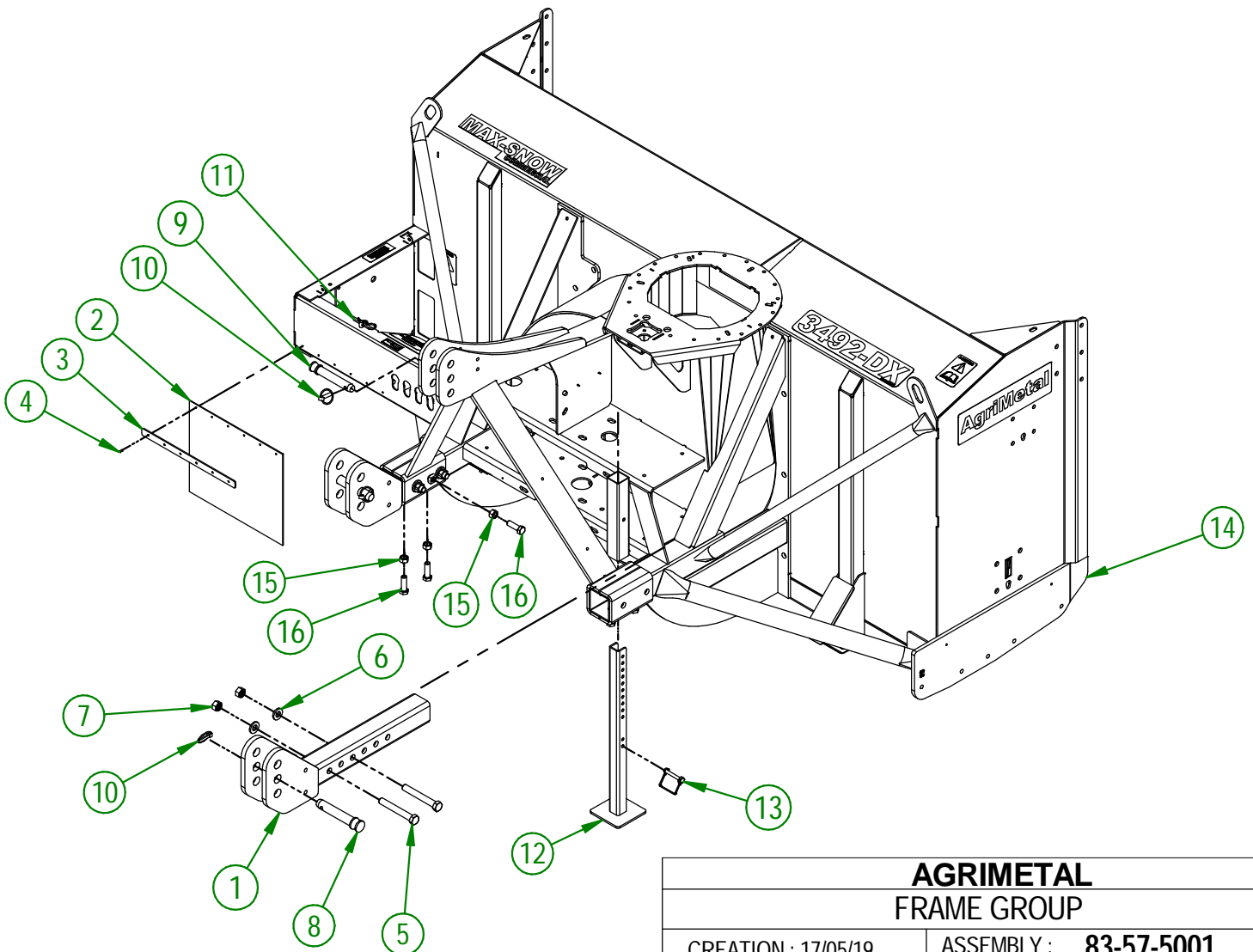

AGRIMETAL
FRAME GROUP

CREATION : 17/05/19
REVISION : 06/01/26

ASSEMBLY : **83-57-5001**
AUTHOR : F.HÉLIE

83-57-5011

#	PART #	Qty	TITLE
1	83-50-5026	1	LEFT SNOW GUARD
2	83-50-5030	1	RIGHT SNOW GUARD
3	NC02-32-0014	6	LOCK WASHER ZINC 1/2"
4	NC01-25-0249	6	HEX. BOLT GR5 ZINC 1/2-13 X 1 1/2" LG

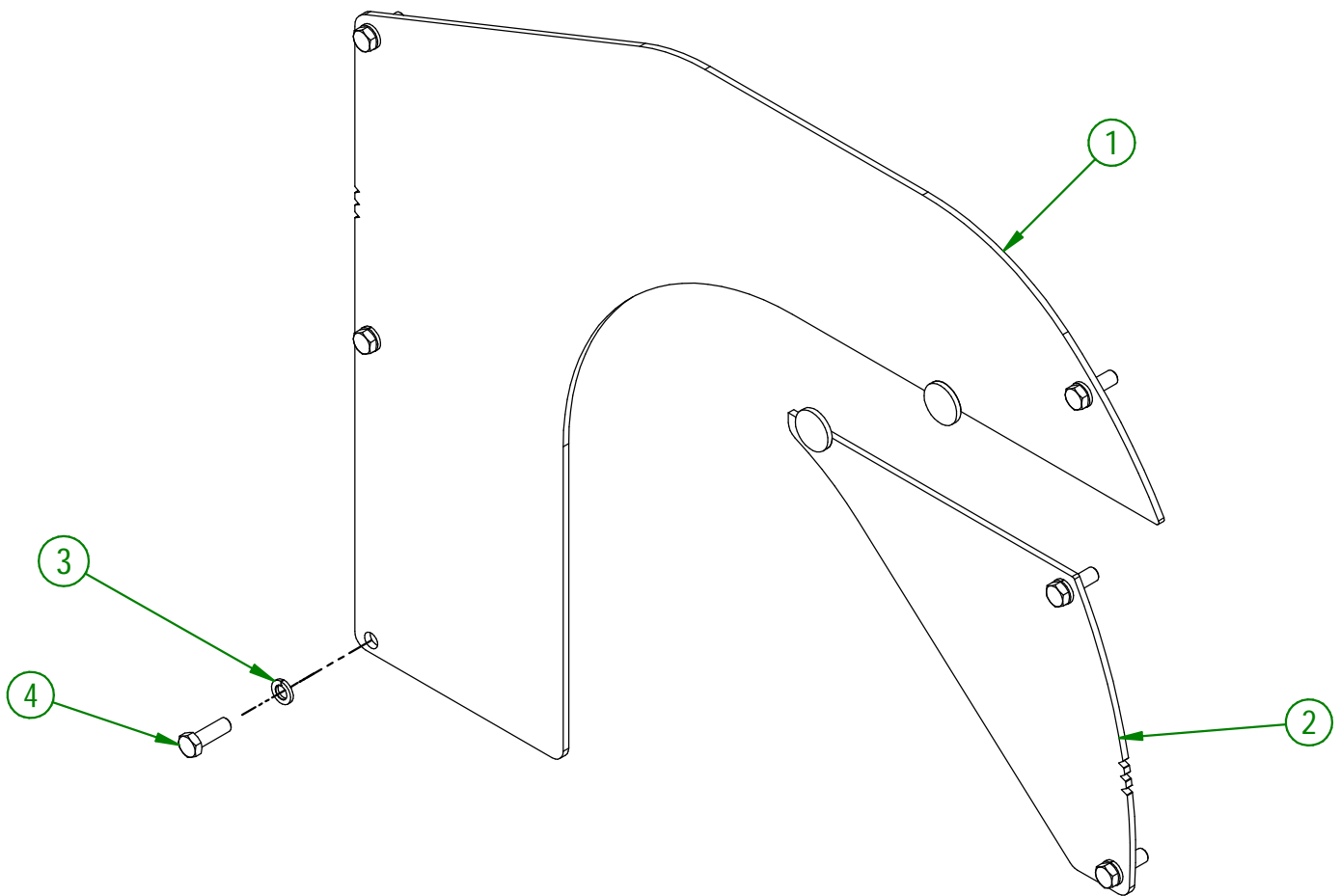

AGRIMETAL	
SNOW GUARD GROUP	
CREATION : 17/05/19	ASSEMBLY : 83-57-5011
REVISION : 06/10/22	AUTHOR : F.HÉLIE

#	PART #	Qty	TITLE
1	83-50-5000	1	IMPELLER
2	80-04-0185	1	WASHER
3	NC02-32-0016	1	LOCK WASHER ZINC 5/8"
4	NC01-25-0395	1	HEX. BOLT GR5 ZINC 5/8-11 X 1 3/4" LG
5	NC01-37-0259	2	HEX. BOLT GR8 NF ZINC 1/2-20 X 4" LG
6	NC01-94-0013	2	NYLON NUT ZINC 1/2-20"
7	83-01-5000	1	WASHER

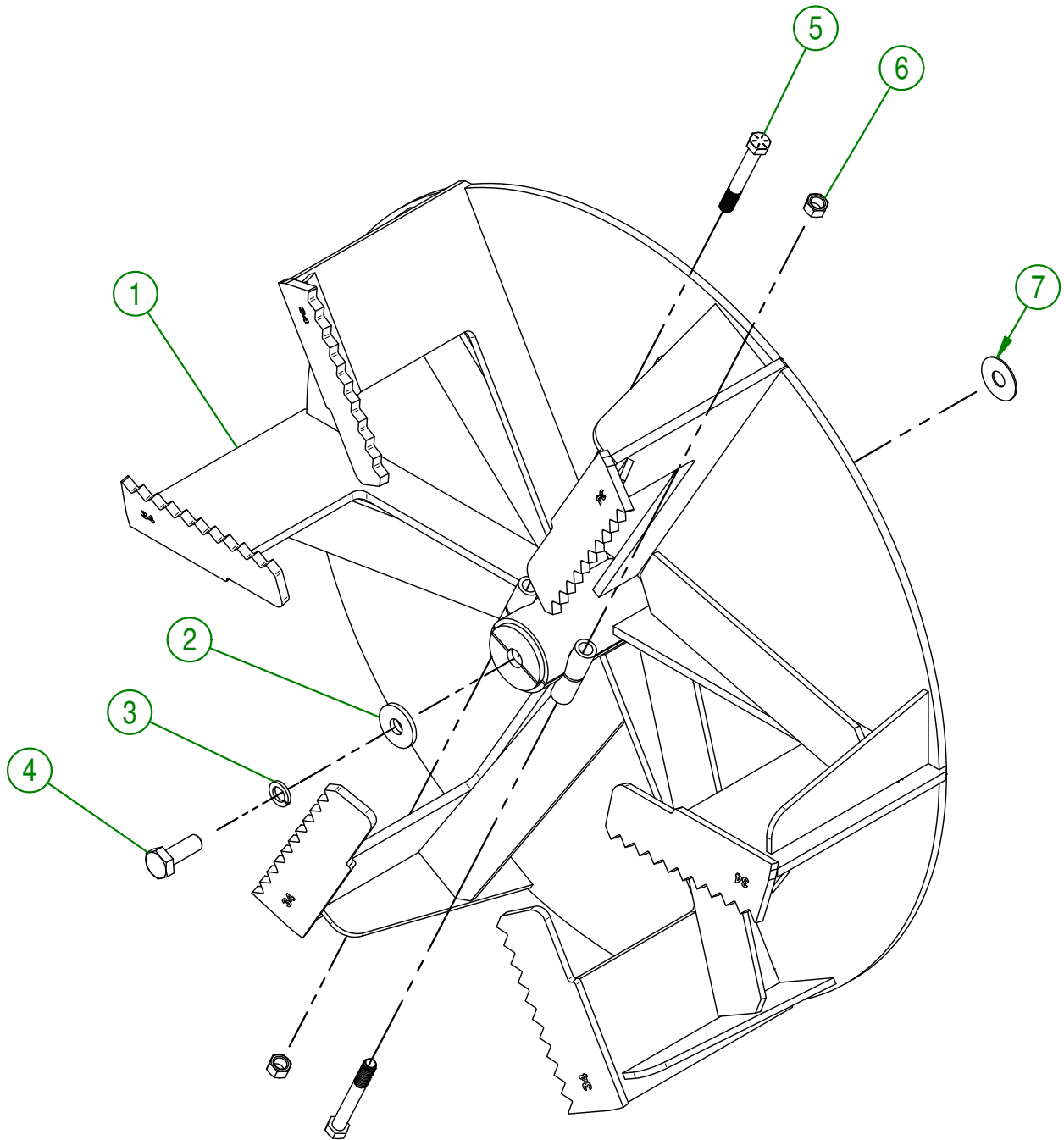

AGRIMETAL
IMPELLER GROUP

CREATION : 28/05/18
 REVISION : 01/02/19

ASSEMBLY : **83-57-5025**

AUTHOR : J. Houle

Page 7 de 21

#	PART #	Qty	TITLE
1	NC14-75-0160	2	FLANGE BEARING UCF207-20 1/4" ID
2	83-50-5055	1	17" SPIRAL
3	NC02-25-0011	12	WASHER SAE ZINC 17/32 ID
4	NC01-17-0250	4	HEX. BOLT GR2 ZINC 1/2-13 X 1 3/4"
5	NC01-17-0251	4	HEX. BOLT GR2 ZINC 1/2-13 X 2"
6	NC02-32-0014	8	LOCK WASHER ZINC 1/2"
7	NC02-07-0020	8	HEX. NUT ZINC 1/2-13
8	80-01-1525	2	SPIRAL SHIM
9	NC14-55-0275	1	80A34 SPROCKET
10	NC01-29-0249	4	HEX. BOLT GR5 ZINC 1/2-20 X 1 1/2
11	NC01-94-0013	4	LOCK NUT 1/2-20
12	82-51-0086	1	SHAFT OF THE SPIRAL
13	83-51-5091	1	SHAFT OF THE SPIRAL (SPROCKET)

REBUILT KIT

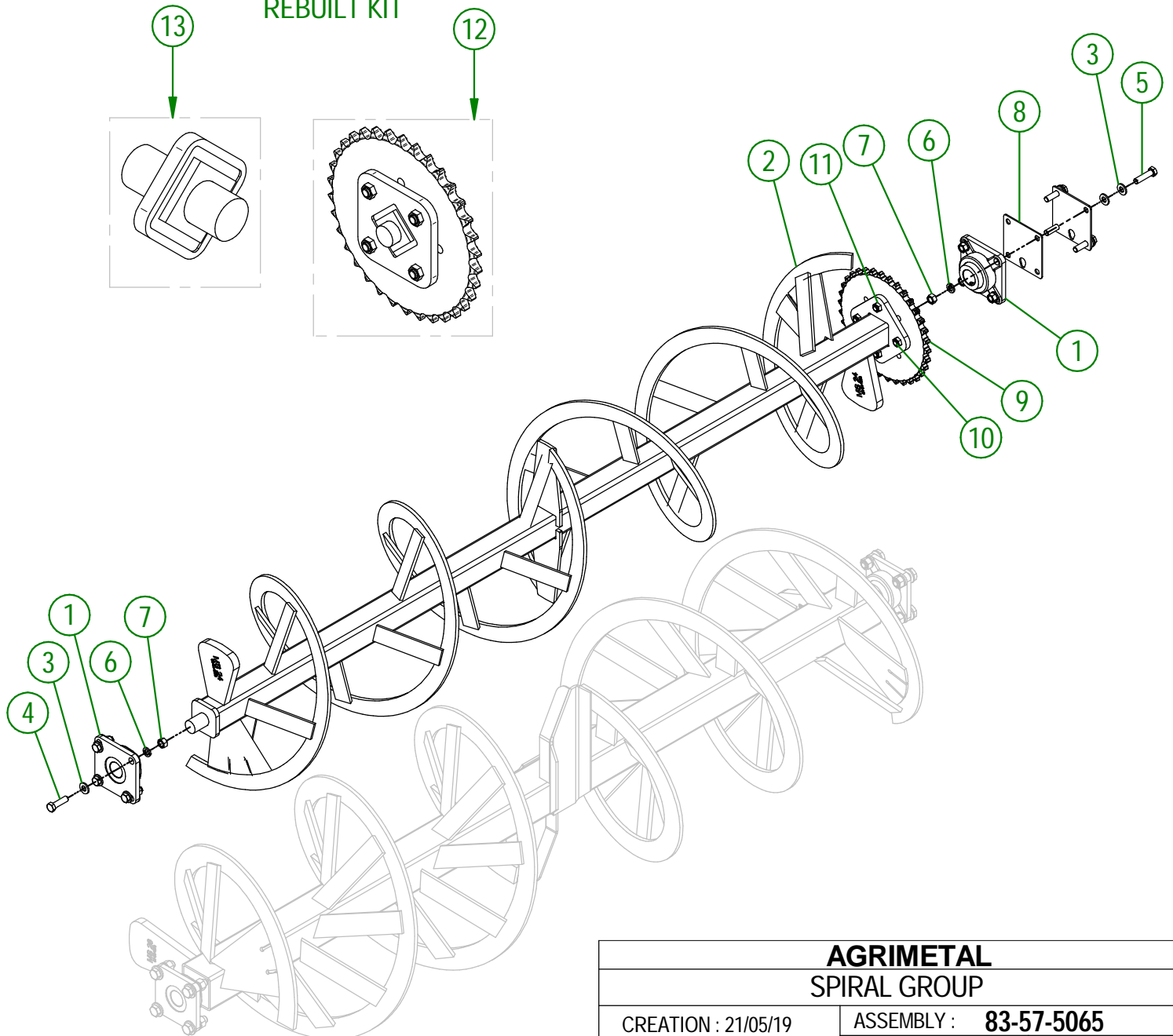

AGRIMETAL
SPIRAL GROUP

CREATION : 21/05/19
REVISION : 06/07/23

ASSEMBLY : **83-57-5065**
AUTHOR : F.HÉLIE

83-57-5046

#	PART #	QTY	TITLE
1	81-04-0010	1	BEARING SUPPORT
2	NC14-75-0025	1	FLANGE BEARING 4 HOLES UCF 208-24 X 1 1/2"
3	81-21-0010	1	SPIRAL DRIVE TRAIN BUSHING
4	NC14-55-0328	1	SPROCKET
5	83-50-0566	1	SPIRAL DRIVE TRAIN
6	81-55-0400	1	CHAIN TENSIONER GROUP
7	83-50-5071	1	CHAIN TENSIONER THREADED ROD
8	NC02-25-0011	1	WASHER SAE ZINC 17/32 ID
9	NC01-96-0014	1	NYLON-INSERT LOCKNUT ZINC 1/2-13
10	80-42-0110	1	THREADED ROD CAP
11	81-04-0135	1	WASHER 2.015" DIA. X 49/64"
12	NC02-32-0017	1	LOCK WASHER ZINC 3/4"
13	NC01-25-0467	1	HEX. BOLT GR2 ZINC 3/4-10 X 2 " LG.
14	NC02-26-1525	8	WASHER INOX .406" D.I. X .815" D.E.
15	NC01-17-0114	8	HEX. BOLT GR2 ZINC 3/8-16 X 1"
16	NC02-32-0012	8	LOCK WASHER ZINC 3/8"
17	NC02-07-0018	8	HEX. NUT ZINC 3/8-16
18	NC01-17-0395	4	HEX. BOLT GR2 ZINC 5/8-11 X 1 3/4"
19	NC02-32-0016	6	LOCK WASHER ZINC 5/8"
20	NC02-07-0022	4	HEX. NUT ZINC 5/8-11
21	NC01-25-0116	1	HEX. BOLT GR5 ZINC 3/8-16 X 1 1/2"
22	NC01-93-0011	1	LOCK NUT 3/8-16
23	NC01-69-0785	2	STRAIGHT GREASE FITTING 1/4-28
24	NC01-69-0787	1	GREASE FITTING STRAIGHT 1/4-28 X 90
25	83-37-0012	1	#80 HD CHAIN 126" LG
26	81-55-0005	2	CHAIN TENSIONER SPROCKET
27	NC02-10-0022	2	HEX. NUT ZINC 5/8-18
28	83-21-0011	2	CHAIN TENSIONER BUSHING
29	NC01-33-0406	2	HEX. BOLT GR8 ZINC 5/8-11 X 4 1/2" LG
30	NC13-86-0054	1	BLUE SPRING 1/2" ID X 1" OD X 6" LG
31	83-57-0160	1	ADJUSTMENT INDICATOR
32	83-04-0550	1	CHAIN TENSIONER BRACE
33	83-21-0020	2	CHAIN TENSIONER BUSHING
34	83-01-0265	1	CHAIN TENSIONER BRACE

81-55-0400

#	PART #	Qty	TITLE
35	88-13-0005	1	CHAIN TENSIONER BUSHING
36	81-50-5005	1	CHAIN TENSIONER
37	81-21-0020	2	CHAIN TENSIONER BUSHING
38	81-55-0005	2	CHAIN TENSIONER SPROCKET
39	NC01-17-0398	2	HEX. BOLT GR2 NC ZINC 5/8-11 X 2 1/2"
40	NC02-22-0013	2	WASHER ZINC 5/8 ID X 1 1/2 OD
41	NC02-32-0016	2	LOCK WASHER ZINC 5/8"
42	NC02-10-0022	2	HEX. NUT ZINC 5/8-18
43	NC01-69-0786	1	GREASE FITTING 1/4-28 X 45

#	PART #	Qty	TITLE
1	NC01-04-0109	10	CARR. BOLT GR2 ZINC 3/8-16 X 1"
2	NC02-14-0019	13	FLANGE NUT HEX. NC 3/8-16 GR. B
3	83-50-5045	1	CHAIN GUARD OF THE DOUBLE SPIRAL (BELOW)
4	83-50-5050	1	CHAIN GUARD OF THE DOUBLE SPIRAL (ABOVE)

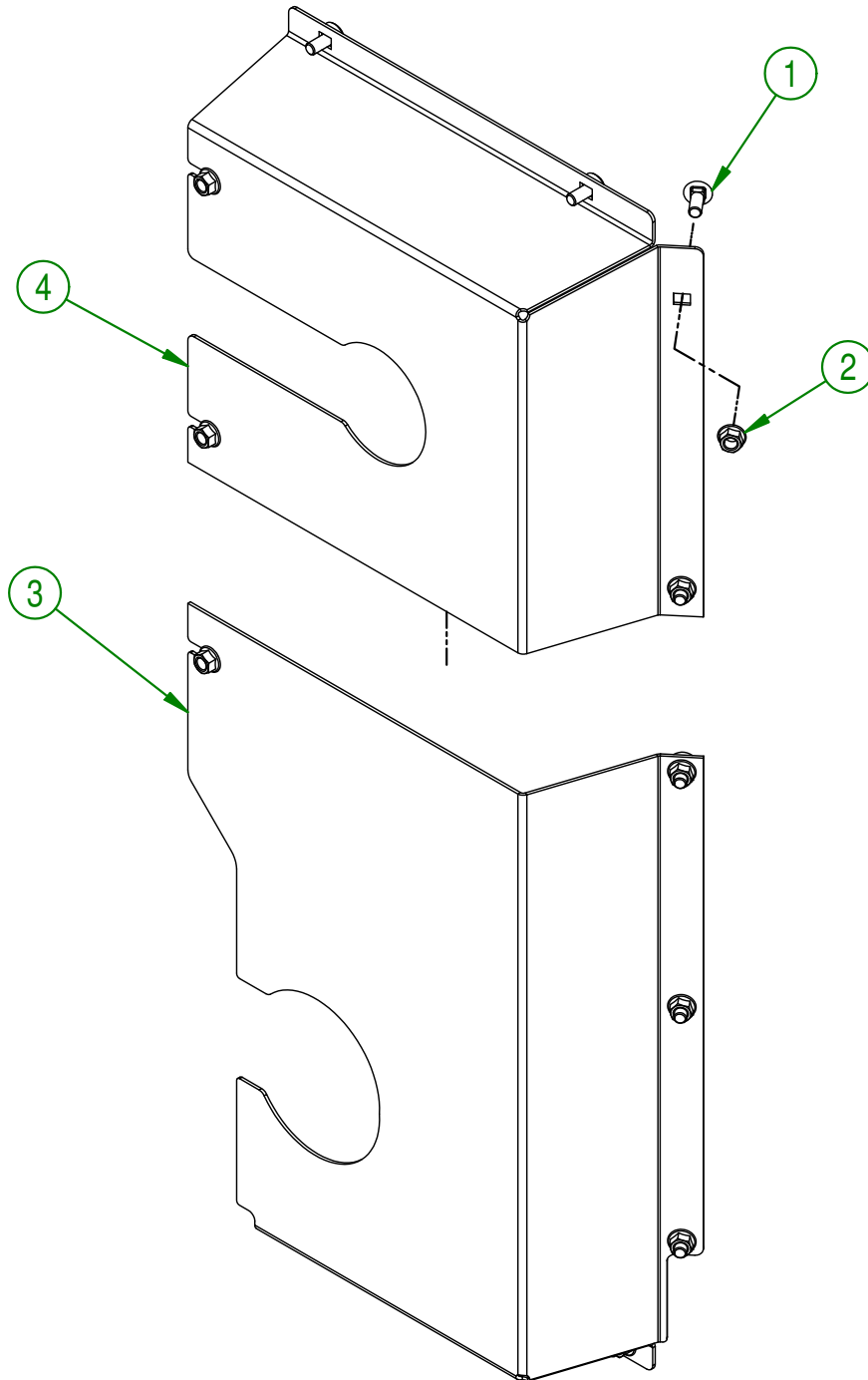

AGRIMETAL	
CHAIN GUARD GROUP	
CREATION : 17/05/19	ASSEMBLY : 83-57-5052
REVISION : 17/05/19	AUTHOR : F.HÉLIE Page 12 de 21

83-57-5016

#	PART #	Qty	TITLE
1	83-57-5006	1	CHAIN GUARD
2	NC02-26-1525	4	WASHER INOX .406" D.I. X .815" D.E.
3	NC01-17-0114	2	HEX. BOLT GR2 ZINC 3/8-16 X 1"
4	NC01-96-0011	2	NYLON NUT 3/8-16

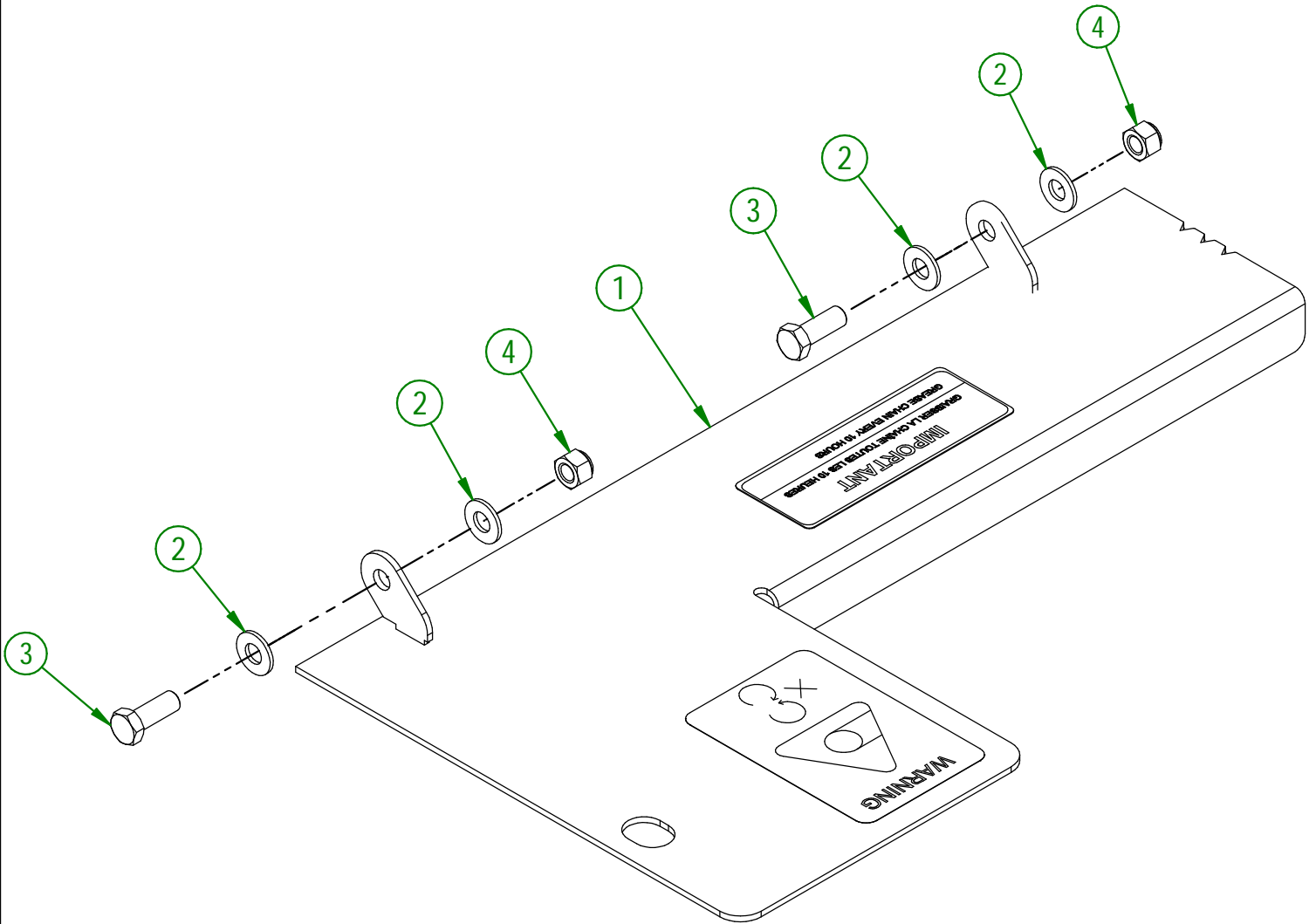

AGRIMETAL	
CHAIN GUARD GROUP	
CREATION : 17/05/19	ASSEMBLY : 83-57-5016
REVISION : 22/12/25	AUTHOR : F.HÉLIE

#	PART #	Qty	TITLE
1	83-55-0010	1	GEAR BOX ASSY.
2	81-57-0040	1	PTO GUARD
3	83-21-0000	4	TRANSMISSION BUSHING
4	83-41-0900	1	IMPELLER KEY
5	NC02-22-0013	6	WASHER ZINC 5/8 ID X 1 1/2 OD
6	NC02-32-0016	8	LOCK WASHER ZINC 5/8"
7	NC01-33-0394	4	HEX. BOLT GR8 NC ZINC 5/8-11 X 1 1/2" LG.
8	NC01-33-0400	4	CAP SCREW GR8 NC ZINC 5/8-11 X 3" LG
9	80-41-0135	1	PTO GUARD STEEL CABLE
10	NC01-64-0005	2	OVAL SLEEVE (ALUMINUM)
11	NC13-25-0019	1	BLACK TIE RAP
12	NC13-50-0110	1	IMPORTANT/NOTICE PTO POSTER
13	83-34-0030	1	PTO SHAFT T90
14	NC01-63-0027	1	HAIRPIN COTTER
15	83-01-0170	1	PTO GUARD SUPPORT
16	80-04-0485	1	GEARBOX BRACE
17	80-04-0480	1	GEARBOX BRACE
18	NC02-25-0011	8	WASHER SAE ZINC 17/32 ID
19	NC02-32-0014	4	LOCK WASHER ZINC 1/2"
20	NC02-07-0020	4	HEX. NUT ZINC 1/2-13
21	NC01-33-0249	4	CAP SCREW GR8 NC ZINC 1/2-13 X 1 1/2" LG
22	01-01-1660	2	WASHER SPACER

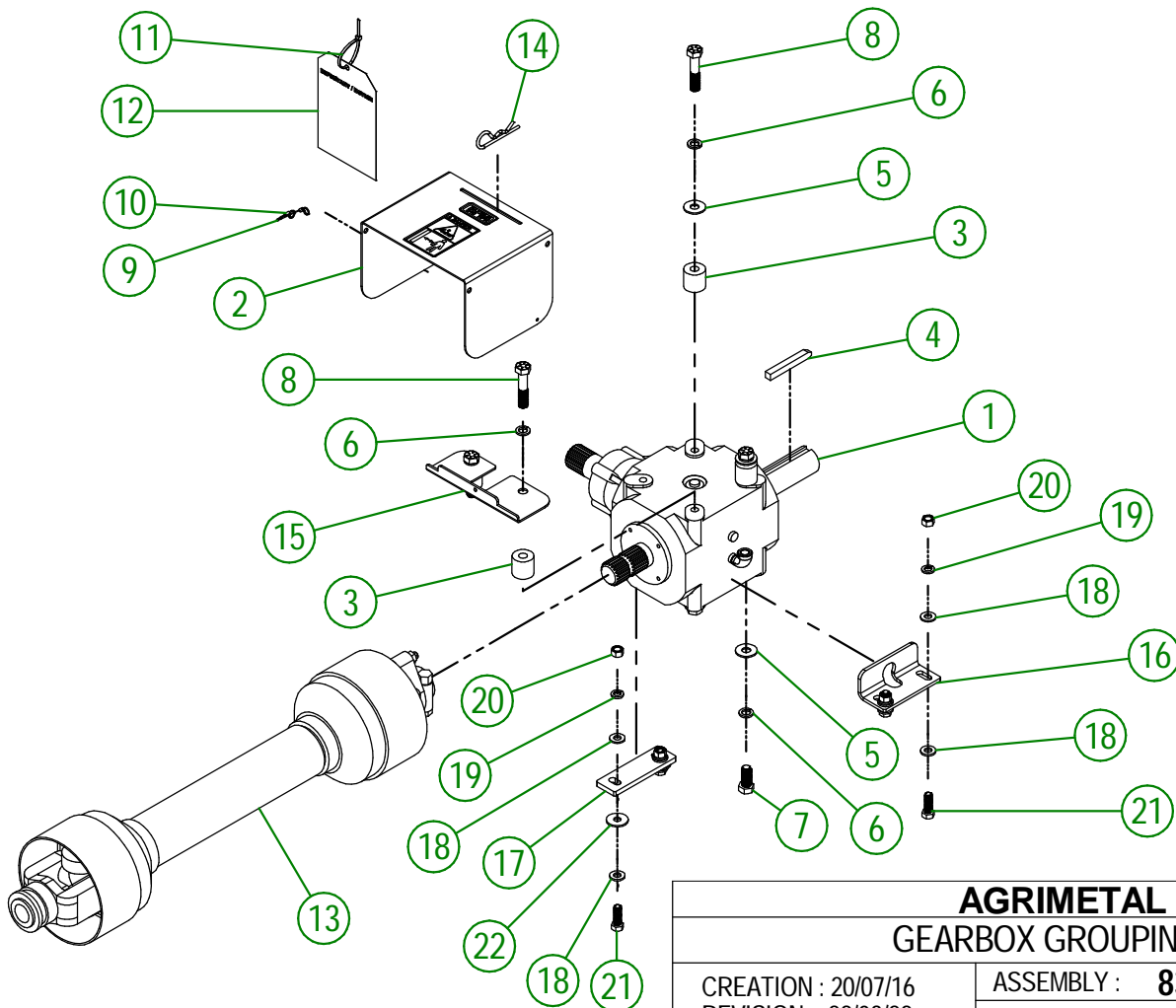

AGRIMETAL
GEARBOX GROUPING

CREATION : 20/07/16
REVISION : 28/03/22

ASSEMBLY : **83-57-0430**
AUTHOR : Dessin2

83-57-0050

#	PART #	Qty	TITLE
1	83-57-0055	1	PTO GUARD "INCL. STICKER"
2	NC01-33-0249	2	CAP SCREW GR8 NC ZINC 1/2-13 X 1 1/2" LG
3	NC02-22-0012	2	WASHER ZINC 1/2 BOLT = 9/16"Ø X 1 3/8" OD
4	NC01-37-0267	2	HEX. BOLT GR8 ZINC 1/2-20 X 6" LG
5	NC01-94-0013	6	NYLON NUT ZINC 1/2-20"
6	NC01-37-0265	4	HEX. BOLT GR8 ZINC 1/2-20 X 5 1/2" LG
7	NC01-93-0014	2	LOCK NUT ZINC 1/2-13
8	NC01-63-0027	1	HAIRPIN COTTER
9	83-50-0125	1	GEARBOX REDUCER SUPPORT
10	NC02-25-0011	10	WASHER SAE ZINC 17/32 ID
11	NC01-25-0251	2	HEX.BOLT GR5 NC ZINC 1/2-13 X 2"
12	NC02-32-0014	2	LOCK WASHER ZINC 1/2"
13	NC02-07-0020	2	HEX. NUT ZINC 1/2-13
14	83-55-0100	1	SPEED REDUCER 1000 TO 540 RPM

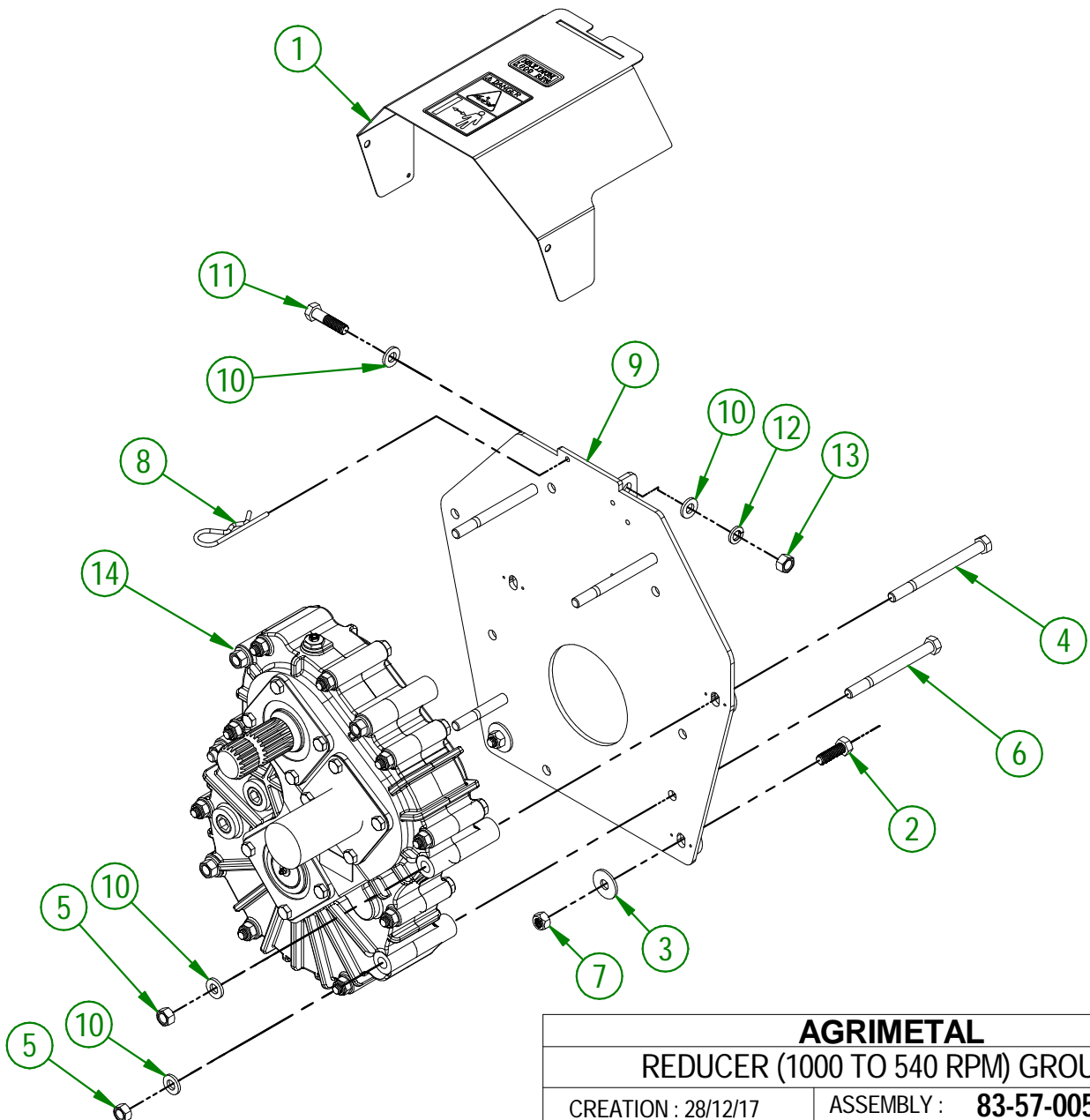

AGRIMETAL	
REDUCER (1000 TO 540 RPM) GROUP	
CREATION : 28/12/17	ASSEMBLY : 83-57-0050
REVISION : 02/07/25	AUTHOR : F.HÉLIE

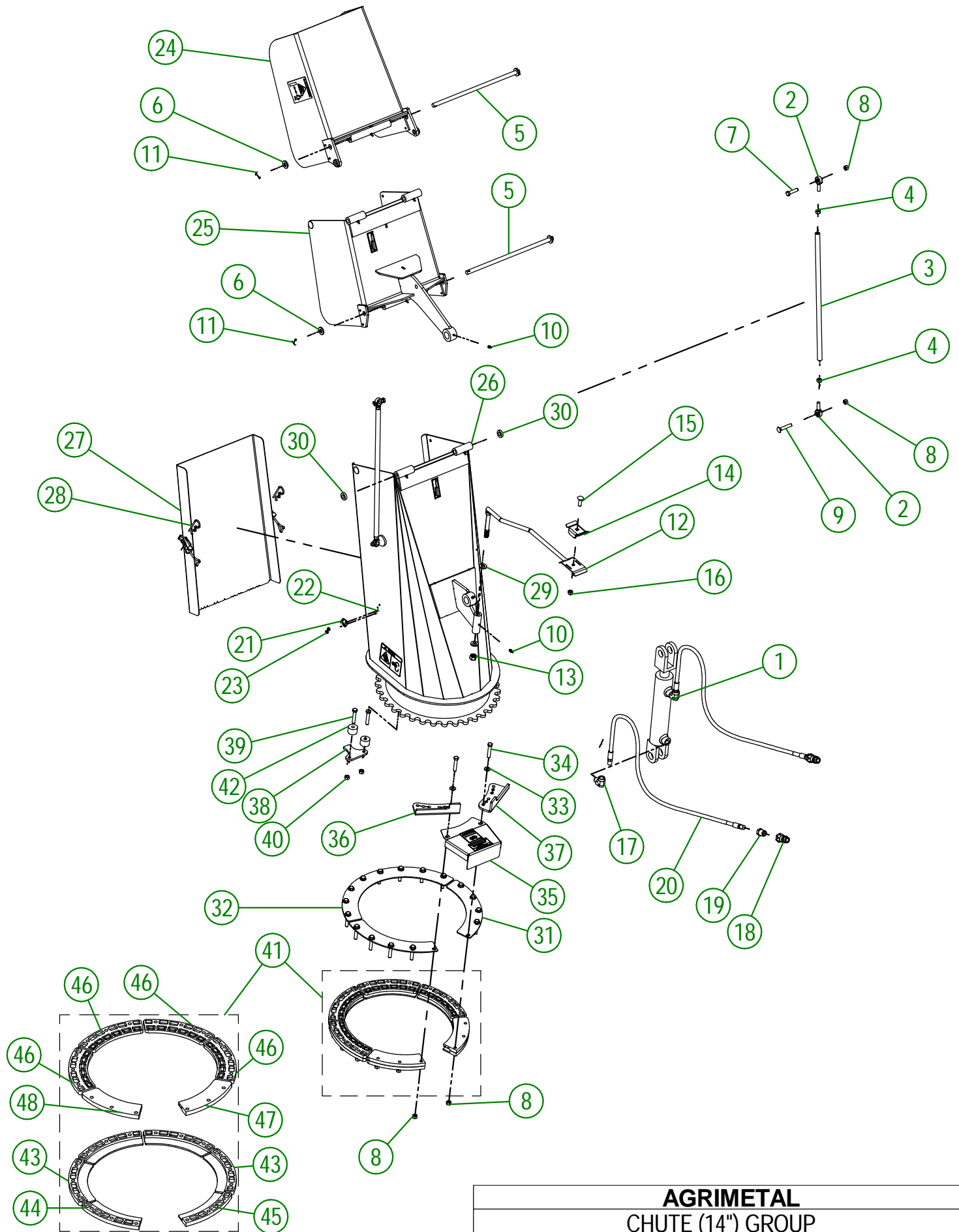

AGRIMETAL		
CHUTE (14'') GROUP		
CREATION : 12/04/19	ASSEMBLY :	81-57-0331
REVISION : 22/12/25	AUTHOR :	dessin3

81-57-0331

#	PART#	QTY	TITLE
1	NC13-45-0404	1	HYDRAULIC CYLINDER 6"
2	NC01-67-0304	4	ROD END 3/8-24
3	48-13-0600	2	CHUTE ROD (DOUBLE)
4	NC02-10-0018	4	NUT 3/8-24
5	81-20-0250	2	PIVOT
6	NC02-25-0011	4	WASHER SAE ZINC 17/32 ID
7	NC01-25-0116	2	HEX. BOLT GR5 ZINC 3/8-16 X 1 1/2"
8	NC01-93-0011	22	LOCK NUT 3/8-16
9	NC01-07-0113	2	CARR. BOLT GR5 ZINC 3/8-16 X 2" LG
10	NC01-69-0785	9	STRAIGHT GREASE FITTING 1/4-28
11	NC01-69-0139	4	COTTER PIN ZINC 1/8" X 3/4"
12	48-50-1030	1	HYDRAULIC HOSE SUPPORT
13	NC01-96-0014	1	NYLON-INSERT LOCKNUT ZINC 1/2-13
14	48-01-7530	1	HYDRAULIC HOSE SUPPORT
15	NC01-04-0110	1	CARR. BOLT GR2 ZINC 3/8-16 X 1 1/4"
16	NC01-96-0011	1	NYLON NUT 3/8-16
17	NC13-45-0038	2	ELBOW 90 3/8 FEM. NPT X 3/8 MALE NPT
18	NC13-45-0369	2	QUICK COUPLER 1/2-14 NPTF
19	NC13-45-0153	2	HEX. REDUCER 1/4 NPT X 1/2 NPT
20	NC17-02-0347	2	HYDRAULIC HOSE (111" LG)
21	NC01-63-0052	2	ADJUSTABLE LATCH (STRIKE)
22	NC02-40-0080	4	MACHINE SCREWS SQUARE SOCKET #10-24 X 1/2" LG
23	NC01-96-0006	4	NYLON NUT ZINC 3/16
24	81-57-0321	1	CHUTE (TOP SECTION)
25	81-57-0311	1	CHUTE (MIDDLE SECTION)
26	81-57-0302	1	CHUTE (BOTTOM SECTION)
27	81-57-0353	1	CHUTE DOOR
28	NC01-63-0026	2	COTTER PIN ZC 5/32" X 3"
29	NC02-25-0011	2	WASHER SAE ZINC 17/32 ID
30	NC13-15-0334	2	PIVOT WASHER
31	48-01-1165	2	BRACE
32	48-01-1167	1	BRACE
33	NC02-26-1525	18	WASHER INOX .406" D.I. X .815" D.E.
34	NC01-17-0118	18	HEX. BOLT GR2 ZINC 3/8-16 X 2"
35	80-57-0550	1	SPROCKET GUARD GROUP "STICKER INCLUDED"
36	81-04-0175	1	ADJUSTABLE STOPPER
37	81-04-0177	1	ADJUSTABLE STOPPER
38	84-04-0170	1	STOPPER
39	NC01-37-0118	2	HEX. BOLT GR8 ZINC 3/8-24 X 2"
40	NC01-94-0011	2	LOCK NUT 3/8-24
41	81-57-0550	1	CHUTE GUIDE GROUP
42	81-21-0040	2	ADJUSTABLE STOPPER SPACER

81-57-0550

#	PART#	QTY	TITLE
43	NC17-46-0025	4	CHUTE GUIDE (UNDER)
44	48-42-0305	1	CHUTE GUIDE (UNDER)
45	48-42-0310	1	CHUTE GUIDE (UNDER)
46	NC17-46-0026	4	CHUTE GUIDE (TOP)
47	48-42-0320	1	CHUTE GUIDE (TOP)
48	48-42-0315	1	CHUTE GUIDE (TOP)

#	PART #	Qty	TITLE
1	NCI3-30-0237	1	PLASTIC TUBE FOR OPERATOR'S MANUAL
2	NC02-25-0007	2	WASHER ZINC 0.281 = 9/32
3	NC01-17-0007	2	HEX. BOLT GR2 ZINC 1/4-20 X 1 1/4"
4	NC01-96-0009	2	NYLON-INSERT LOCKNUT ZINC 1/4-20
5	81-57-0030	1	SET OF 6 SHEAR BOLT WITH NUT
6	81-98-0521	1	ENGLISH OPERATOR'S MANUAL (MS28 & 30)

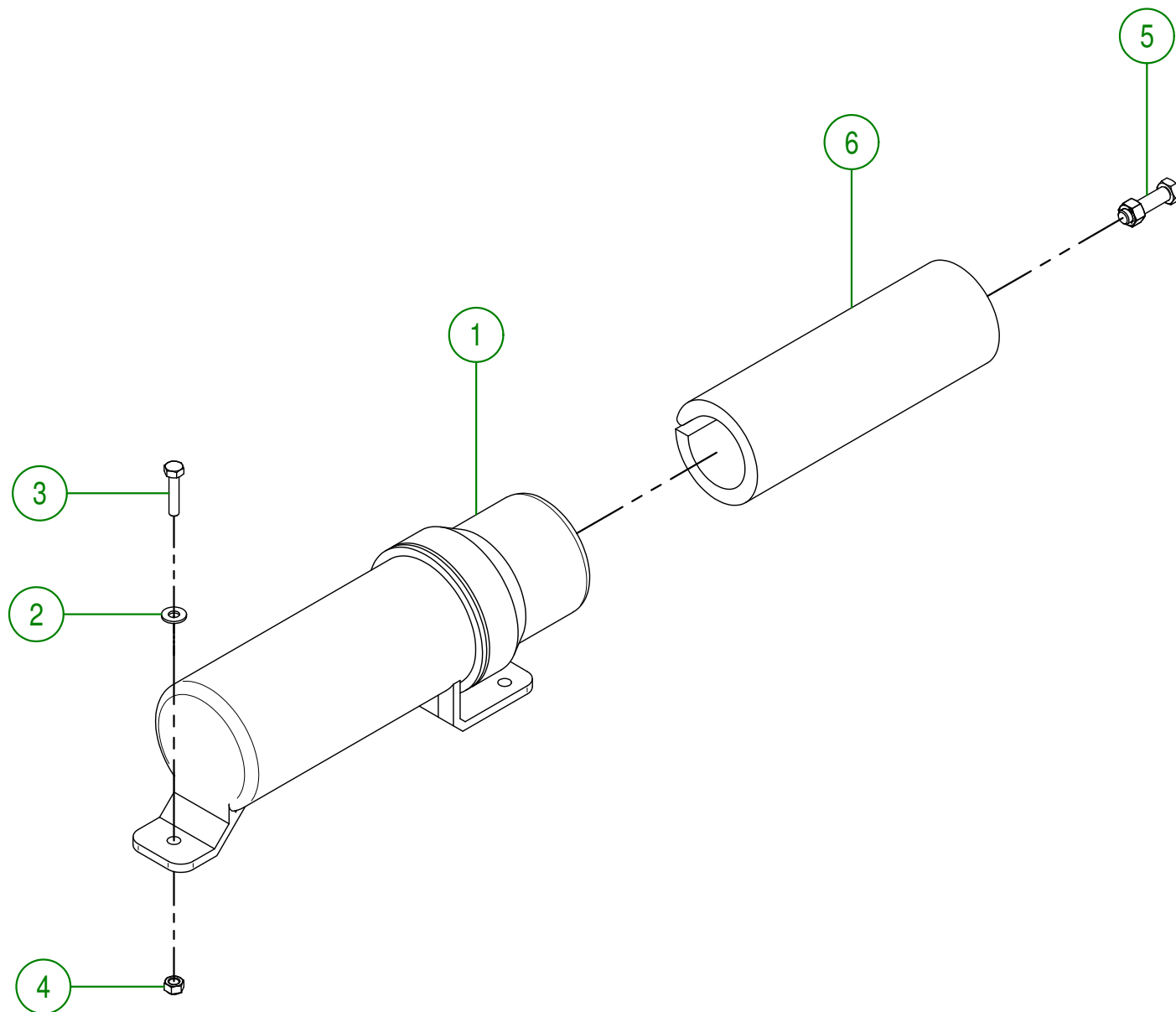

AGRIMETAL	
OPERATOR'S MANUAL TUBE GROUP	
CREATION : 19/07/16	ASSEMBLY : 81-57-0400
REVISION : 21/05/19	AUTHOR : J. HOULE Page 19 de 21

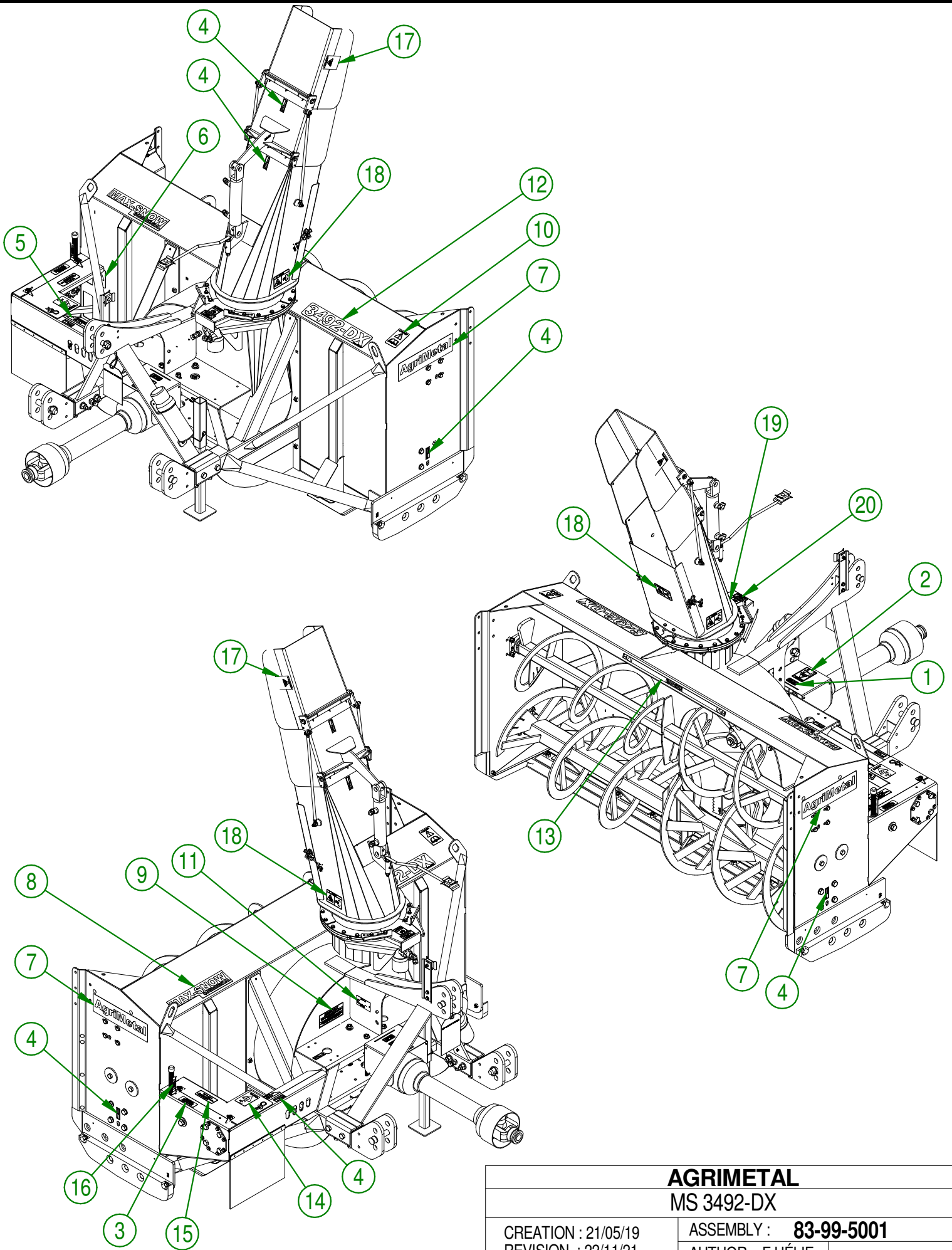

AGRIMETAL
MS 3492-DX

CREATION : 21/05/19
 REVISION : 22/11/21

ASSEMBLY : **83-99-5001**
 AUTHOR : F.HÉLIE

83-99-5001

#	PART #	QTY	TITLE
1	NC13-33-0005	1	STICKER MAXIMUM 540 RPM
2	NC13-33-0187	1	STICKER DANGER (PTO AND PERSON)
3	NC13-33-0248	1	STICKER IMPORTANT 4 1/4 INCHES 110mm
4	NC13-33-0024	6	STICKER GREASE HERE
5	NC13-33-0281	1	STICKER SHEAR BOLT
6	NC13-33-0189	1	STICKER DANGER (PERSON AND CHAIN DRIVE)
7	NC13-33-0001	2	STICKER AGRIMETAL
8	NC13-33-0241	1	STICKER MAX-SNOW COMMERCIAL
9	NC13-33-0317	1	STICKER GREASE DRIVE LINE TELESCOPIC SHAFT
10	NC13-33-0183	1	STICKER CAUTION OPERATION MANUAL
11	NC13-50-0086	1	SERIAL NUMBER PLATE
12	NC13-33-0320	1	STICKER 3492-DX
13	NC13-33-0274	1	STICKER DANGER
14	NC13-33-0283	1	STICKER DANGER (PERSON AND CHAIN DRIVE)
15	NC13-33-0343	1	GREASE CHAIN EVERY 10 HOURS STICKER
16	NC13-33-0344	1	ADJUSTEMENT INDICATOR STICKER
17	NC13-33-0192	2	STICKER (PROJECTION RISK)
18	NC13-33-0249	3	STICKER DANGER
19	NC13-33-0326	1	STICKER DANGER (HAND)
20	NC13-33-0327	1	STICKER END ROTATION ADJUSTMENT

AGRIMETAL**MS 3492-DX**

CREATION : 21/05/19
 REVISION : 22/11/21

ASSEMBLY : **83-99-5001**

AUTHOR : F.HÉLIE