

# AgriMetal

## PARTS LIST

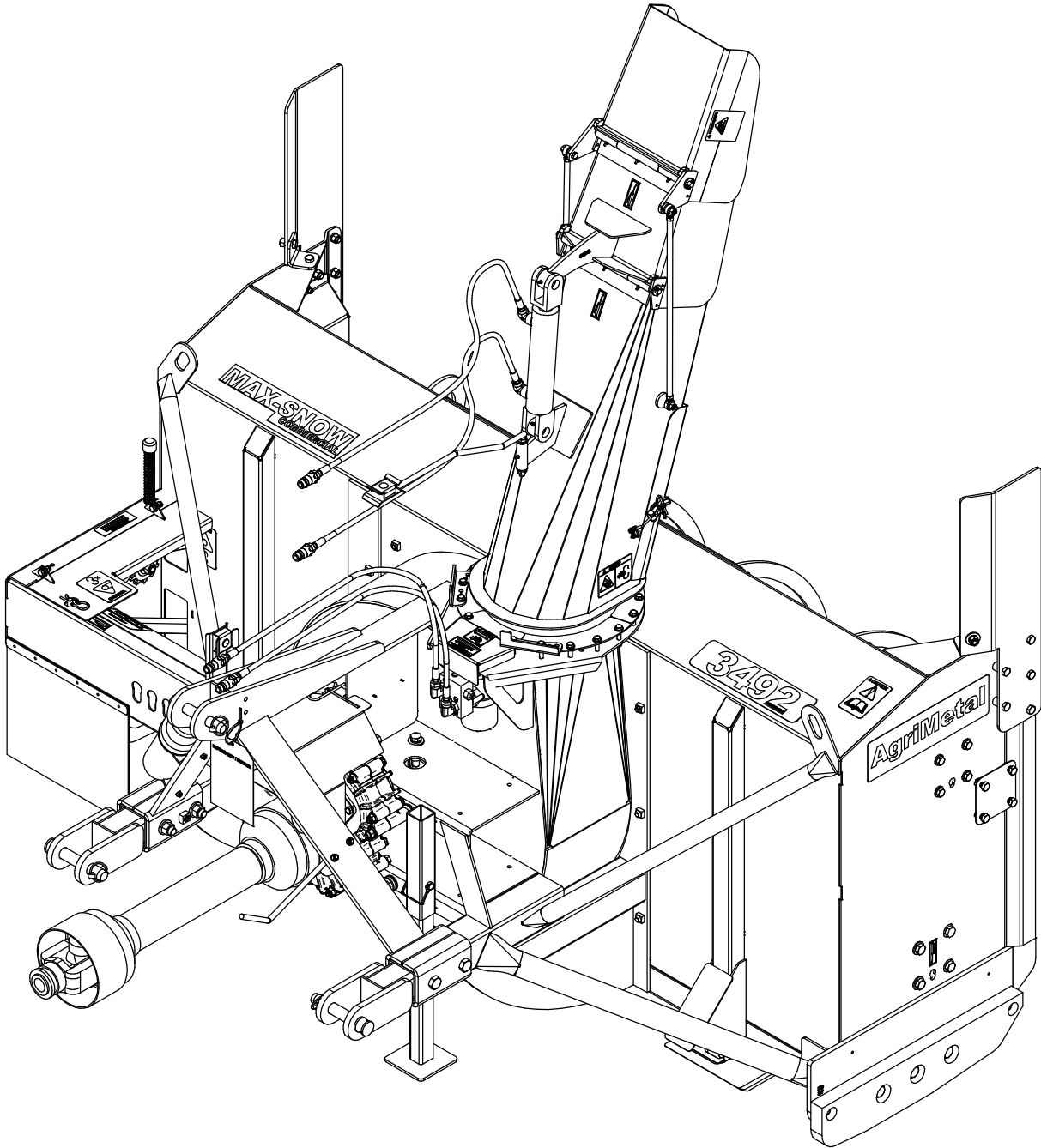

**MS 3492**

81-57-0700

#	PART #	Qty	TITLE
1	80-50-0085	2	LATERAL SKATE (#450 HARDNESS STEEL)
2	81-50-0055	2	ADJUSTABLE SKATE (#450 HARDNESS STEEL)
3	NC02-48-0586	4	FLAT HEAD SOCKET CAP SCREW 5/8-11 X 1" LG
4	81-57-0230	2	KNIFE (#450 HARDNESS STEEL) GROUP (BOLTS AND NUTS INCLUDED)
5	NC01-25-0481	2	HEX. BOLT GR5 NC 3/4-10 X 5"
6	NC01-96-0017	2	HEX. LOCK NUT NYLO. NC 3/4-10

81-57-0230

#	PART #	Qty	TITLE
7	NC01-93-0016	5	LOCK NUT ZINC 5/8-11
8	NC01-09-0039	5	PLOW BOLT GR5 5/8-11 X 1 1/2" LG

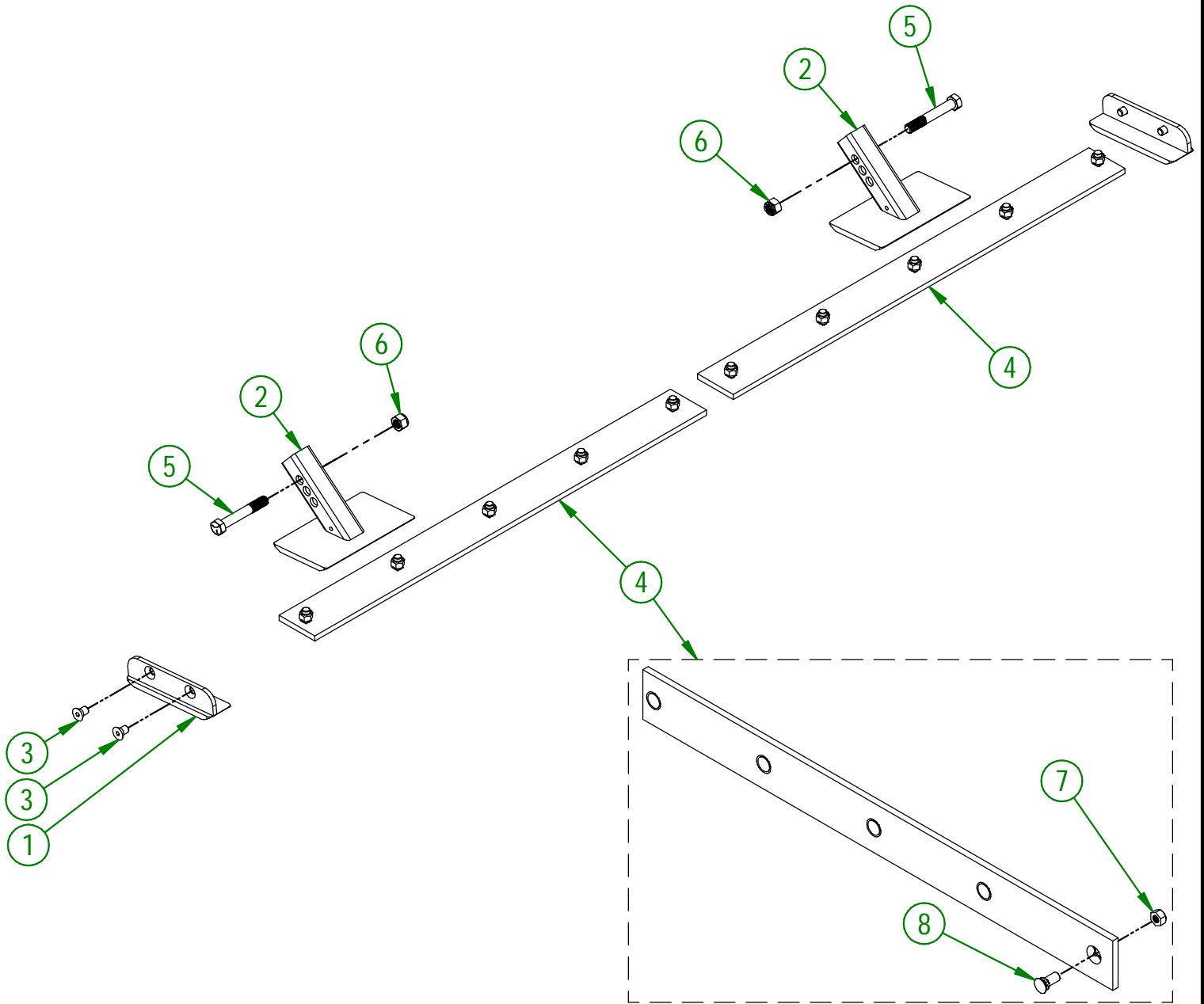

<b>AGRIMETAL</b>	
<b>SET OF KNIVES (#450 HARDNESS STEEL)</b>	
CREATION : 19/07/16	ASSEMBLY : <b>81-57-0700</b>
REVISION : 20/05/25	AUTHOR : Dessin2

81-57-0710

#	PART #	Qty	TITLE
1	NC02-48-0586	4	FLAT HEAD SOCKET CAP SCREW 5/8-11 X 1" LG
2	80-50-0087	2	LATERAL SKATE (STAINLESS STEEL)
3	81-50-0058	2	ADJUSTABLE SKATE (STAINLESS STEEL)
4	81-57-0235	2	KNIFE (STAINLESS STEEL) GROUP (BOLTS AND NUTS INCLUDED)
5	NC01-25-0481	2	HEX. BOLT GR5 NC 3/4-10 X 5"
6	NC01-96-0017	2	HEX. LOCK NUT NYLO. NC 3/4-10

81-57-0235

#	PART #	Qty	TITLE
5	NC02-48-0562	5	FLAT HEAD SOCKET CAP SCREW STAINLESS 5/8-11 X 1 1/2"
6	NC01-93-0016	5	LOCK NUT ZINC 5/8-11

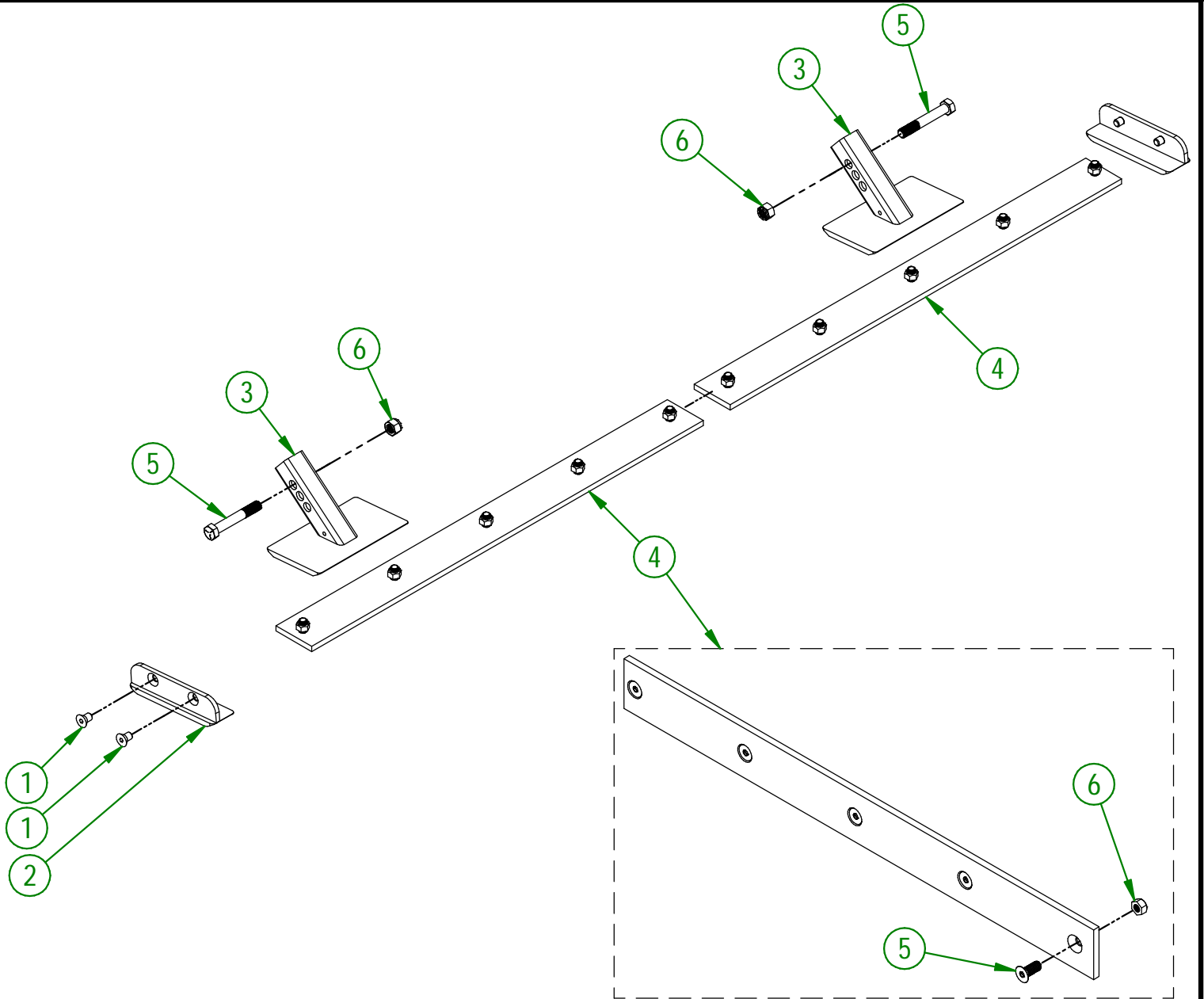

<b>AGRIMETAL</b>	
<b>SET OF KNIVES (STAINLESS STEEL)</b>	
CREATION : 19/07/16	ASSEMBLY : <b>81-57-0710</b>
REVISION : 20/05/25	AUTHOR : Dessin2

81-57-0705

#	PART #	Qty	TITLE
1	81-50-0700	2	KNIFE BRACE (TOP)
2	81-42-0105	1	RIGHT KNIFE (UHMW)
3	81-42-0106	1	LEFT KNIFE (UHMW)
4	81-04-0350	2	KNIFE BRACE (UNDER)
5	NC02-48-0564	10	FLAT HEAD SOCKET CAP SCREW STAINLESS 5/8-11 X 2" LG
6	NC01-93-0016	10	LOCK NUT ZINC 5/8-11
7	81-42-0103	1	LATERAL KNIFE (RIGHT)
8	81-42-0104	1	LATERAL KNIFE (LEFT)
9	NC02-25-0011	4	WASHER SAE ZINC 17/32 ID
10	80-04-0185	6	WASHER
11	NC01-17-0394	6	HEX. BOLT GR2 ZINC 5/8-11 X 1 1/2"
12	NC01-17-0250	2	HEX. BOLT GR2 ZINC 1/2-13 X 1 3/4"
13	NC01-17-0251	2	HEX. BOLT GR2 ZINC 1/2-13 X 2"
14	NC01-93-0014	4	LOCK NUT ZINC 1/2-13

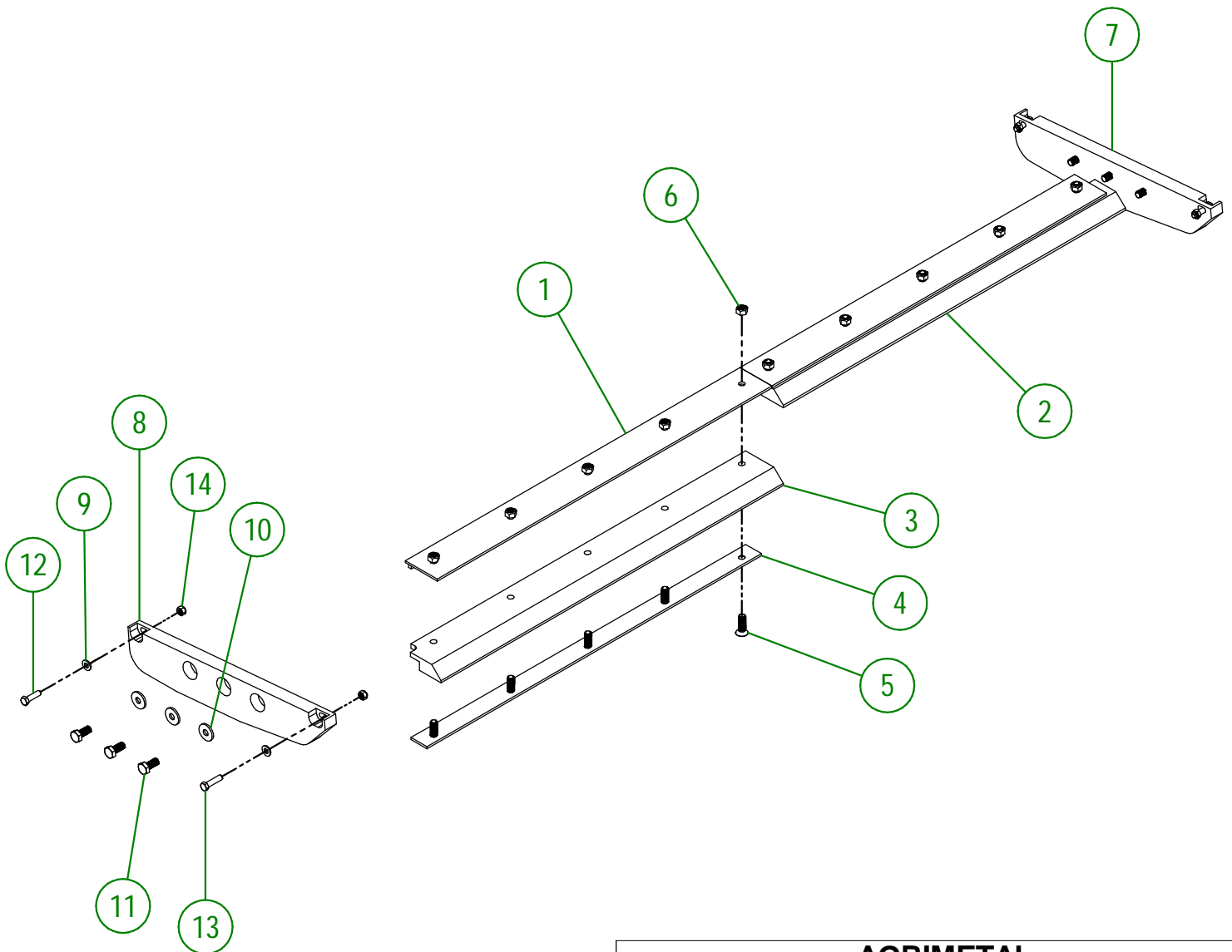

<b>AGRIMETAL</b>	
<b>SET OF KNIVES (UHMW)</b>	
CREATION : 19/07/16	ASSEMBLY : <b>81-57-0705</b>
REVISION : 27/09/23	AUTHOR : J. HOULE

#	PART #	Qty	TITLE
1	81-20-0337	1	LATERAL CUTTER BLADES (LEFT)
2	81-20-0335	1	LATERAL CUTTER BLADES (RIGHT)
3	81-10-0000	4	LATERAL CUTTER BLADES BUSHING
4	NC01-25-0248	10	HEX. BOLT GR5 ZINC 1/2-13 X 1 1/4"
5	NC01-25-0252	4	HEX. BOLT GR5 ZINC 1/2-13 X 2 1/4"
6	NC02-32-0014	14	LOCK WASHER ZINC 1/2"
7	NC02-07-0020	14	HEX. NUT ZINC 1/2-13
8	81-04-0525	2	LATERAL KNIFE REINFORCE
9	NC02-22-0012	2	WASHER ZINC 1/2 BOLT = 9/16"Ø X 1 3/8" OD

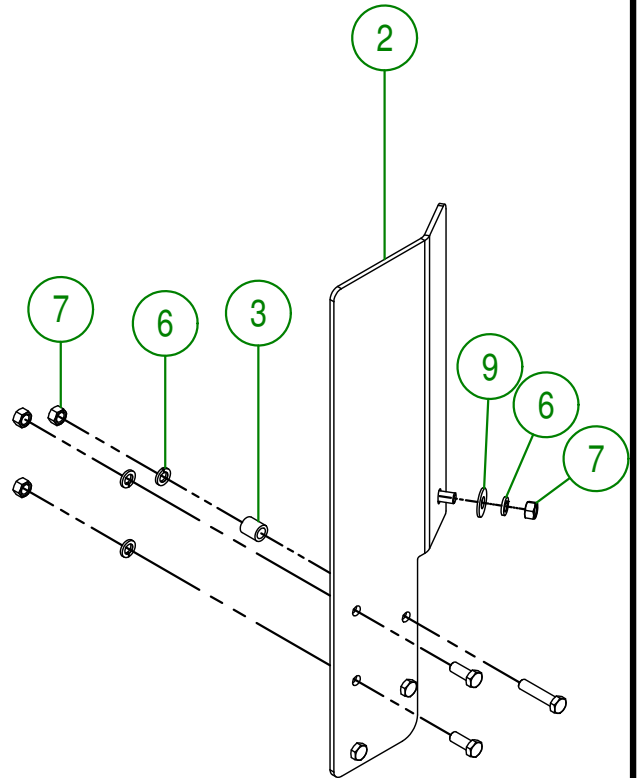
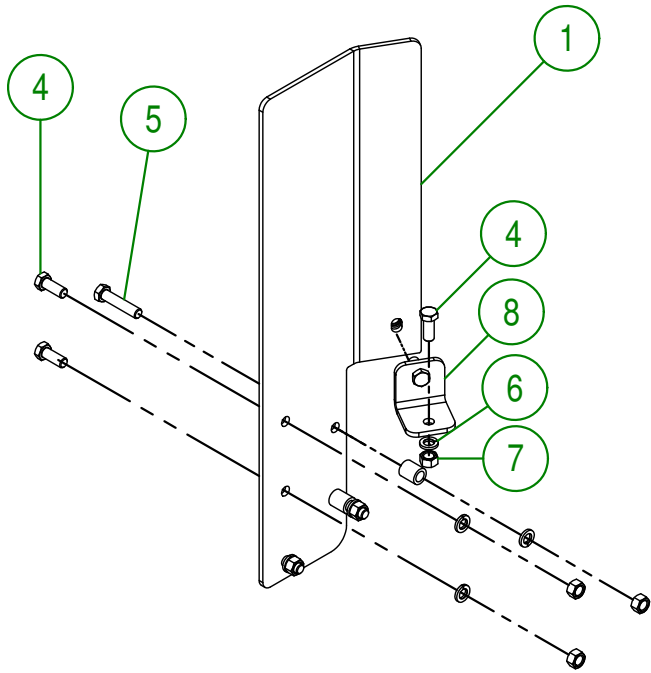

<b>AGRIMETAL</b>	
<b>LATERAL CUTTER BLADES</b>	
CREATION : 24/11/17	ASSEMBLY : <b>81-57-0215</b>
REVISION : 01/02/19	AUTHOR : J. Houle      Page 4 de 23

84-57-1315

#	PART #	Qty	TITLE
1	84-50-1310	1	PTO SUPPORT
2	01-01-2485	2	FLAT WASHER 14 GA X 13/16"OD X 25/64" ID
3	NC02-32-0012	2	LOCK WASHER ZINC 3/8"
4	NC02-07-0018	2	HEX. NUT ZINC 3/8-16

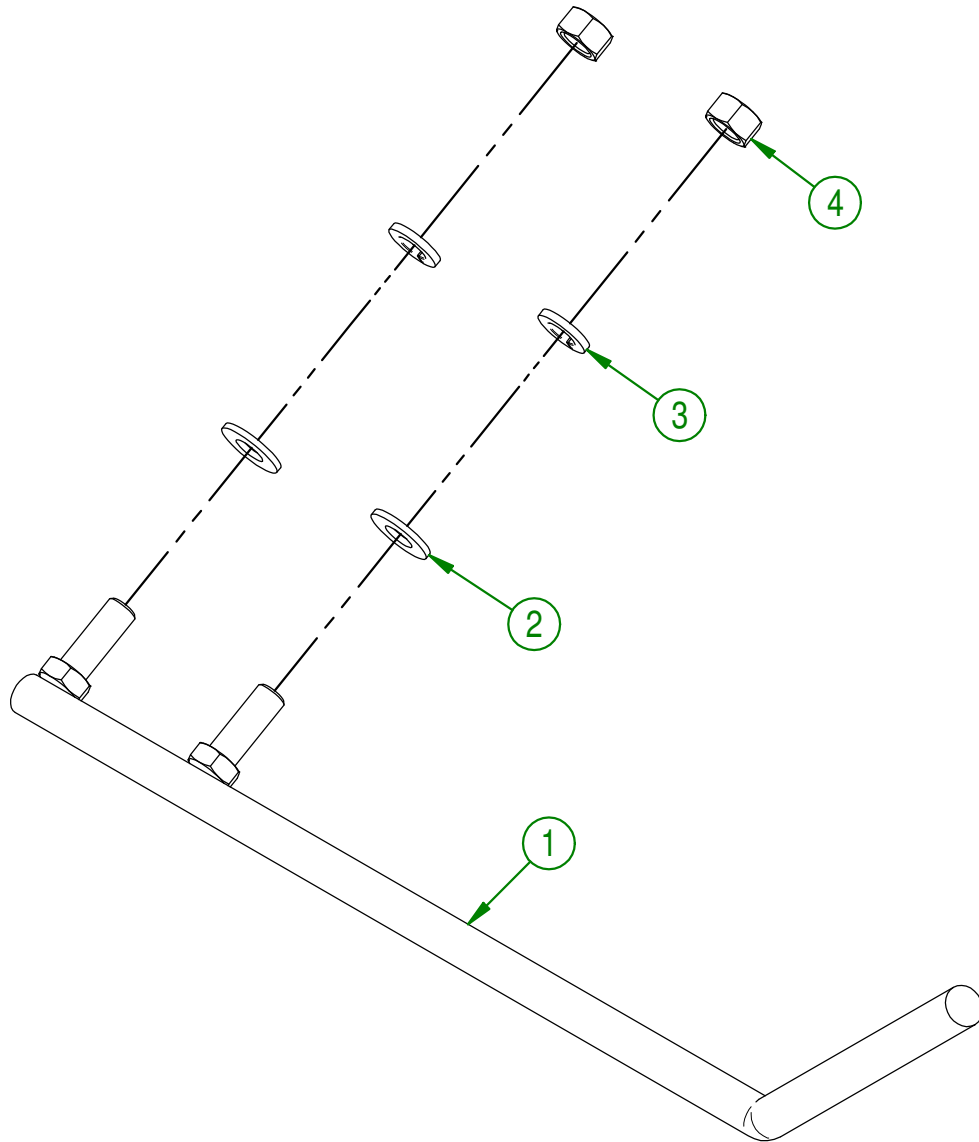

<b>AGRIMETAL</b>	
PTO SUPPORT GROUP (OPTION)	
CREATION : 06/12/17	ASSEMBLY : <b>84-57-1315</b>
REVISION : 17/10/18	AUTHOR : J.KABWE   Page 5 de 23

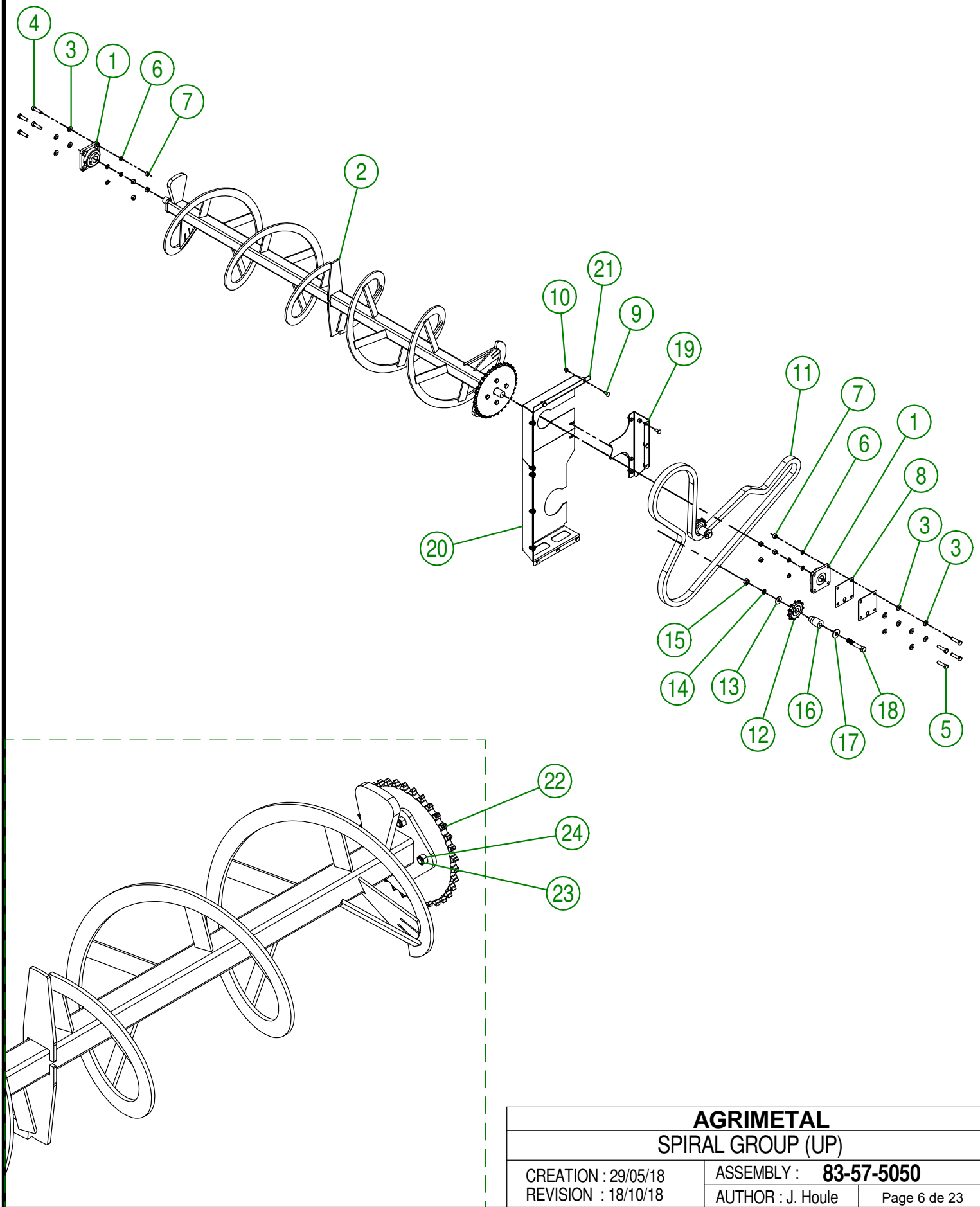

<b>AGRIMETAL</b>	
<b>SPIRAL GROUP (UP)</b>	
CREATION : 29/05/18	ASSEMBLY : <b>83-57-5050</b>
REVISION : 18/10/18	AUTHOR : J. Houle
	Page 6 de 23

#	PART #	Qty	TITLE
1	NC14-75-0160	2	FLANGE BEARING UCF207-20 1 1/4" ID
2	83-50-5055	1	17" SPIRAL
3	NC02-25-0011	12	WASHER SAE ZINC 17/32 ID
4	NC01-17-0250	4	HEX. BOLT GR2 ZINC 1/2-13 X 1 3/4"
5	NC01-17-0251	4	HEX. BOLT GR2 ZINC 1/2-13 X 2"
6	NC02-32-0014	8	LOCK WASHER ZINC 1/2"
7	NC02-07-0020	8	HEX. NUT ZINC 1/2-13
8	80-01-1525	2	SPIRAL SHIM
9	NC01-04-0109	13	CARR. BOLT GR2 ZINC 3/8-16 X 1"
10	NC02-14-0019	16	FLANGE NUT HEX. NC 3/8-16 GR. B
11	83-37-0010	1	#80 HD CHAIN
12	NC14-55-0292	2	80C11H SPROCKET
13	NC02-22-0013	2	WASHER ZINC 5/8 ID X 1 1/2 OD
14	NC02-32-0016	2	LOCK WASHER ZINC 5/8"
15	NC02-10-0022	2	HEX. NUT ZINC 5/8-18
16	83-21-0010	2	CHAIN TENSIONER BUSHING
17	80-04-0185	2	WASHER
18	NC01-17-0404	2	HEX. BOLT GR2 ZINC 5/8-11 X 3 1/2"
19	83-50-5040	1	CHAIN GUARD HOLDER
20	83-50-5045	1	CHAIN GUARD OF THE DOUBLE SPIRAL (BELOW)
21	83-50-5050	1	CHAIN GUARD OF THE DOUBLE SPIRAL (ABOVE)
22	NC14-55-0275	1	SPROCKET 80A34 X 1 1/2"
23	NC01-29-0249	4	HEX. BOLT GR5 NF ZINC 1/2-20 X 1 1/2"
24	NC01-94-0013	4	LOCKNUT ZINC 1/2-20

83-57-0050

#	PART #	Qty	TITLE
1	83-57-0055	1	PTO GUARD "INCL. STICKER"
2	NC01-33-0249	2	CAP SCREW GR8 NC ZINC 1/2-13 X 1 1/2" LG
3	NC02-22-0012	2	WASHER ZINC 1/2 BOLT = 9/16"Ø X 1 3/8" OD
4	NC01-37-0267	2	HEX. BOLT GR8 ZINC 1/2-20 X 6" LG
5	NC01-94-0013	6	NYLON NUT ZINC 1/2-20"
6	NC01-37-0265	4	HEX. BOLT GR8 ZINC 1/2-20 X 5 1/2" LG
7	NC01-93-0014	2	LOCK NUT ZINC 1/2-13
8	NC01-63-0027	1	HAIRPIN COTTER
9	83-50-0125	1	GEARBOX REDUCER SUPPORT
10	NC02-25-0011	10	WASHER SAE ZINC 17/32 ID
11	NC01-25-0251	2	HEX.BOLT GR5 NC ZINC 1/2-13 X 2"
12	NC02-32-0014	2	LOCK WASHER ZINC 1/2"
13	NC02-07-0020	2	HEX. NUT ZINC 1/2-13
14	83-55-0100	1	SPEED REDUCER 1000 TO 540 RPM

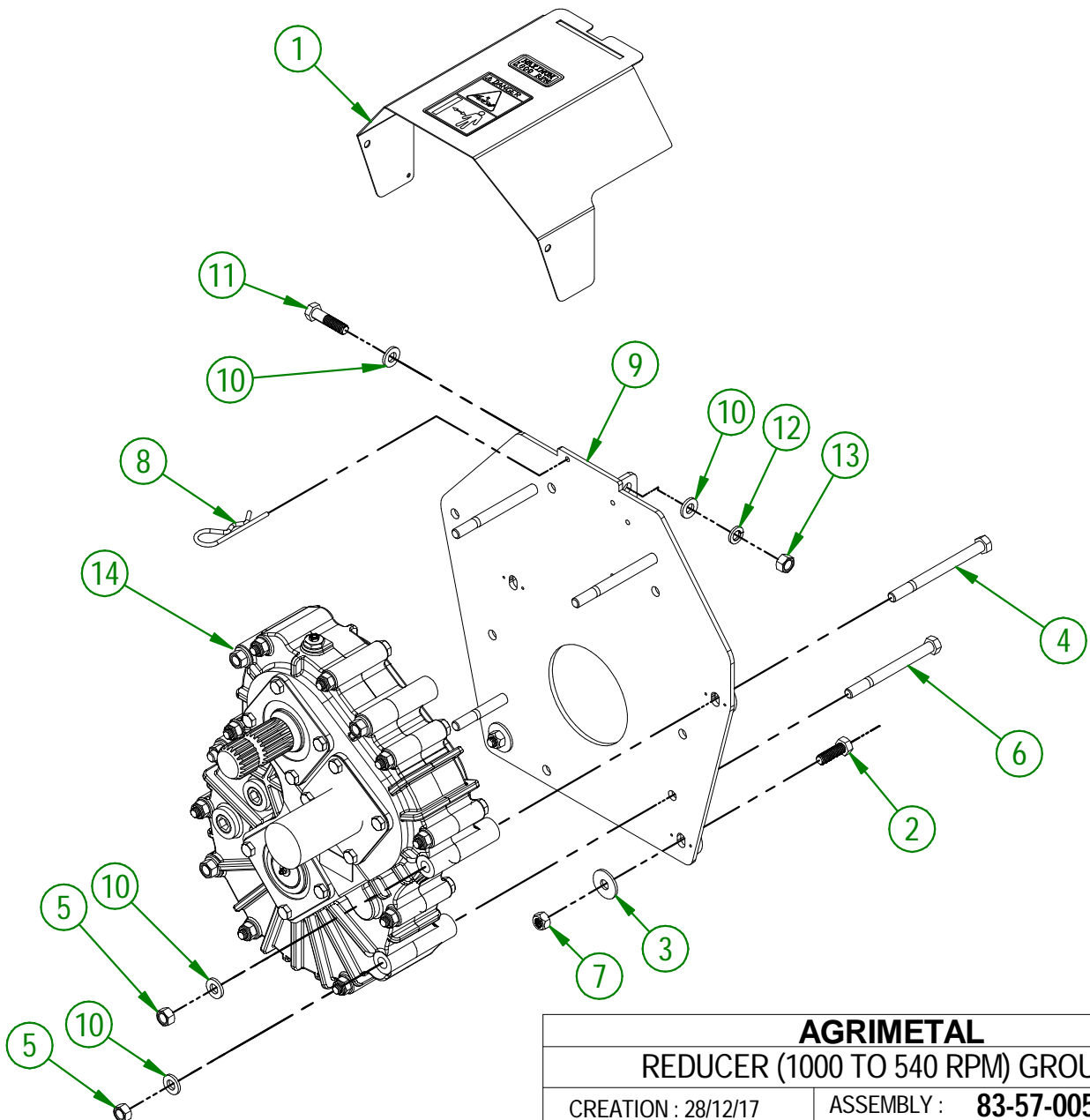

<b>AGRIMETAL</b>	
<b>REDUCER (1000 TO 540 RPM) GROUP</b>	
CREATION : 28/12/17	ASSEMBLY : <b>83-57-0050</b>
REVISION : 02/07/25	AUTHOR : F.HÉLIE

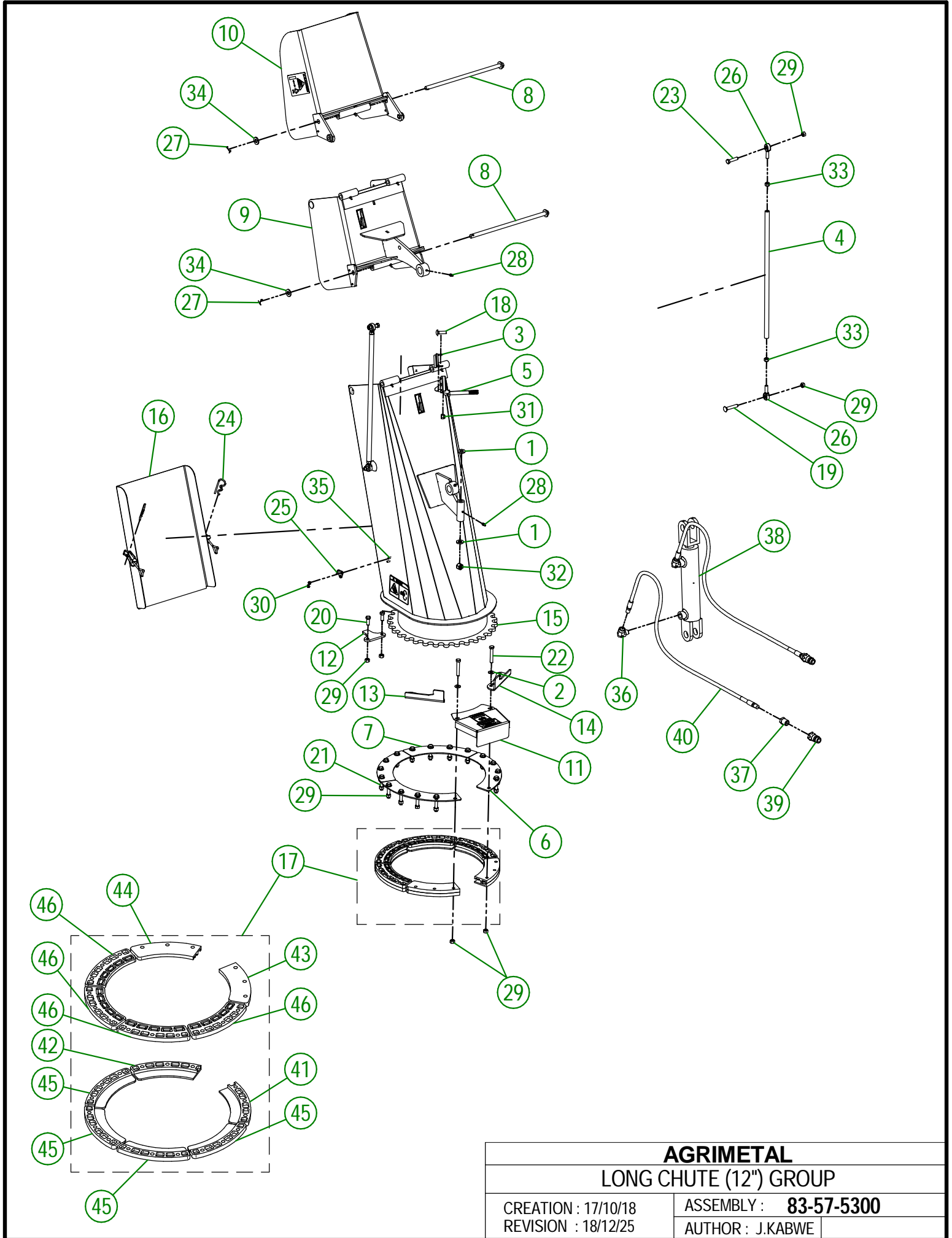

**AGRIMETAL**  
**LONG CHUTE (12") GROUP**

CREATION : 17/10/18  
 REVISION : 18/12/25

ASSEMBLY : **83-57-5300**  
 AUTHOR : J.KABWE

## 83-57-5300

#	PART #	Qty	TITLE
1	01-01-0925	2	WASHER
2	01-01-2485	18	FLAT WASHER 14 GA X 13/16"OD X 25/64" ID
3	48-01-7530	1	HYDRAULIC HOSE SUPPORT
4	48-13-0600	2	CHUTE ROD (DOUBLE)
5	48-50-1030	1	HYDRAULIC HOSE SUPPORT
6	80-01-1010	2	BRACE
7	80-01-1015	2	BRACE
8	80-20-0260	2	PIVOT
9	80-57-0312	1	CHUTE (MIDDLE SECTION)
10	80-57-0322	1	CHUTE (TOP SECTION)
11	80-57-0550	1	SPROCKET GUARD GROUP "STICKER INCLUDED"
12	84-04-0170	1	STOPPER
13	84-04-0175	1	ADJUSTABLE STOPPER
14	84-04-0177	1	ADJUSTABLE STOPPER
15	84-57-1305	1	CHUTE (BOTTOM SECTION)
16	84-57-1310	1	CHUTE DOOR
17	84-57-1330	1	GUIDE CHUTE GROUP
18	NC01-04-0110	1	CARR. BOLT GR2 ZINC 3/8-16 X 1 1/4"
19	NC01-07-0113	2	CARR. BOLT GR5 ZINC 3/8-16 X 2" LG
20	NC01-17-0114	2	HEX. BOLT GR2 ZINC 3/8-16 X 1"
21	NC01-17-0118	14	HEX. BOLT GR2 ZINC 3/8-16 X 2"
22	NC01-17-0119	4	HEX. BOLT GR2 ZINC 3/8-16 X 2 1/4"
23	NC01-25-0116	2	HEX. BOLT GR5 ZINC 3/8-16 X 1 1/2"
24	NC01-63-0026	2	COTTER PIN ZC 5/32" X 3"
25	NC01-63-0052	2	ADJUSTABLE LATCH (STRIKE)
26	NC01-67-0304	4	ROD END 3/8-24
27	NC01-69-0139	4	COTTER PIN ZINC 1/8" X 3/4"
28	NC01-69-0785	9	STRAIGHT GREASE FITTING 1/4-28
29	NC01-93-0011	24	LOCK NUT 3/8-16
30	NC01-96-0006	4	NYLON NUT ZINC 3/16
31	NC01-96-0011	1	NYLON NUT 3/8-16
32	NC01-96-0014	1	NYLON-INSERT LOCKNUT ZINC 1/2-13
33	NC02-10-0018	4	NUT 3/8-24
34	NC02-25-0011	4	WASHER SAE ZINC 17/32 ID
35	NC02-40-0080	4	MACHINE SCREWS SQUARE SOCKET #10-24 X 1/2" LG
36	NC13-45-0038	2	ELBOW 90 3/8 FEM. NPT X 3/8 MALE NPT
37	NC13-45-0153	2	HEX. REDUCER 1/4 NPT X 1/2 NPT
38	NC13-45-0209	1	HYDRAULIC CYLINDER 6"
39	NC13-45-0369	2	QUICK COUPLER 1/2-14 NPTF
40	NC17-02-0347	2	HYDRAULIC HOSE (111" LG)

84-57-1330

#	PART #	Qty	TITLE
41	80-42-0305	1	CHUTE GUIDE (UNDER)
42	80-42-0310	1	CHUTE GUIDE (UNDER)
43	80-42-0315	1	CHUTE GUIDE (TOP)
44	80-42-0320	1	CHUTE GUIDE (TOP)
45	NC17-46-0027	4	CHUTE GUIDE (UNDER)
46	NC17-46-0028	4	CHUTE GUIDE (TOP)

#	PART #	QTY	TITLE
1	83-50-5020	2	ATTACHMENT HAND
2	NC13-15-0300	1	SNOW GUARD
3	80-01-1075	1	SNOW GUARD BRACE
4	NC01-78-0041	6	POP RIVET STAINLESS STEEL ROD STEEL .187" X .690"
5	NC01-33-0481	4	HEX. BOLT GR8 ZINC 3/4-10 X 5 1/2"
6	22-04-6805	4	FLAT WASHER BEARING BASE
7	NC01-93-0017	4	HEX. LOCKNUT STEEL NC Z 3/4-10
8	48-20-0065	2	3 POINT PIN
9	48-20-0060	1	3 POINT PIN
10	NC01-69-1100	3	LINCH PIN 3/8"
11	NC01-63-0026	3	COTTER PIN ZC 5/32" X 3"
12	83-50-5035	1	STAND
13	NC01-69-1306	1	LOCKING PIN 3/8" X 2 1/2" LG
14	49-20-0210	2	ADJUSTABLE SKATE PIN
15	83-57-5055	1	FRAME
16	NC13-15-0326	1	RUBBER
17	81-57-0250	1	RUBBER REINFORCEMENT
18	NC01-17-0060	7	HEX. BOLT GR2 ZINC 5/16-18 X 1"
19	NC01-93-0010	7	LOCK NUT ZINC 5/16-18
20	NC02-07-0022	6	HEX. NUT ZINC 5/8-11
21	NC01-17-0396	6	HEX. BOLT GR2 ZINC 5/8-11 X 2"

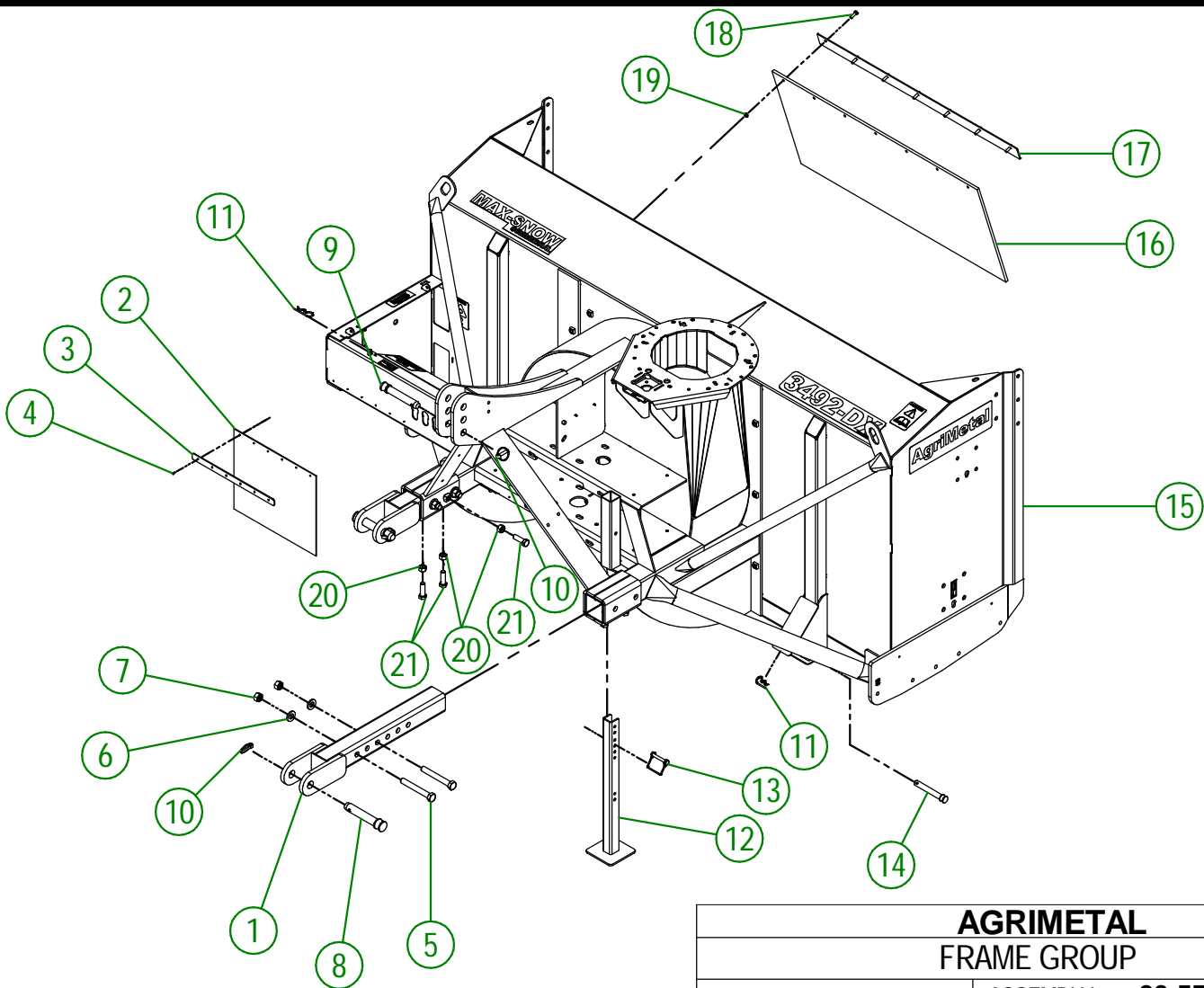

<b>AGRIMETAL</b>	
<b>FRAME GROUP</b>	
CREATION : 28/05/18	ASSEMBLY : <b>83-57-5000</b>
REVISION : 06/01/26	AUTHOR : J. Houle

#	PART #	Qty	TITLE
1	48-01-7527	1	HYDRAULIC HOSE SUPPORT
2	48-50-1025	1	HYDRAULIC ENGINE SPROCKET
3	80-13-0100	2	HYDRAULIC RESTRICTOR
4	80-45-0000	2	HEX. REDUCER 1/4 NPT X 1/2 NPT
5	81-01-7600	1	HYDRAULIC HOSE SUPPORT
6	NC01-04-0111	1	CARR. BOLT GR2 ZINC 3/8-16 X 1 1/2"
7	NC01-17-0115	2	HEX. BOLT GR2 ZINC 3/8-16 X 1 1/4"
8	NC01-33-0113	4	HEX.BOLT GR8 ZINC 3/8-16 X 3/4"
9	NC01-45-0184	1	HEX. BOLT GR8.8 ZINC 8MM X 20MM
10	NC01-96-0011	1	NYLON NUT 3/8-16
11	NC02-07-0018	2	HEX. NUT ZINC 3/8-16
12	NC02-26-0504	1	WASHER
13	NC02-26-1525	2	WASHER INOX .406" D.I. X .815" D.E.
14	NC02-32-0011	1	LOCK WASHER ZINC 5/16"
15	NC02-32-0012	6	LOCK WASHER ZINC 3/8"
16	NC02-44-0103	2	SET SCREW 5/16-18 X 3/8"
17	NC13-45-0367	2	45°-7/8-14 MALE O RING X 1/2 FEM.TOUR.NPT PT
18	NC13-45-0369	2	QUICK COUPLER 1/2-14 NPTF
19	NC13-45-0378	2	HYDRAULIC RESTRICTOR BUSHING
20	NC14-45-0156	1	HYDRAULIC MOTOR
21	NC17-02-0406	2	HYDRAULIC HOSE (87" LG)
22	NC17-46-0031	1	HYDRAULIC MOTOR BUSHING

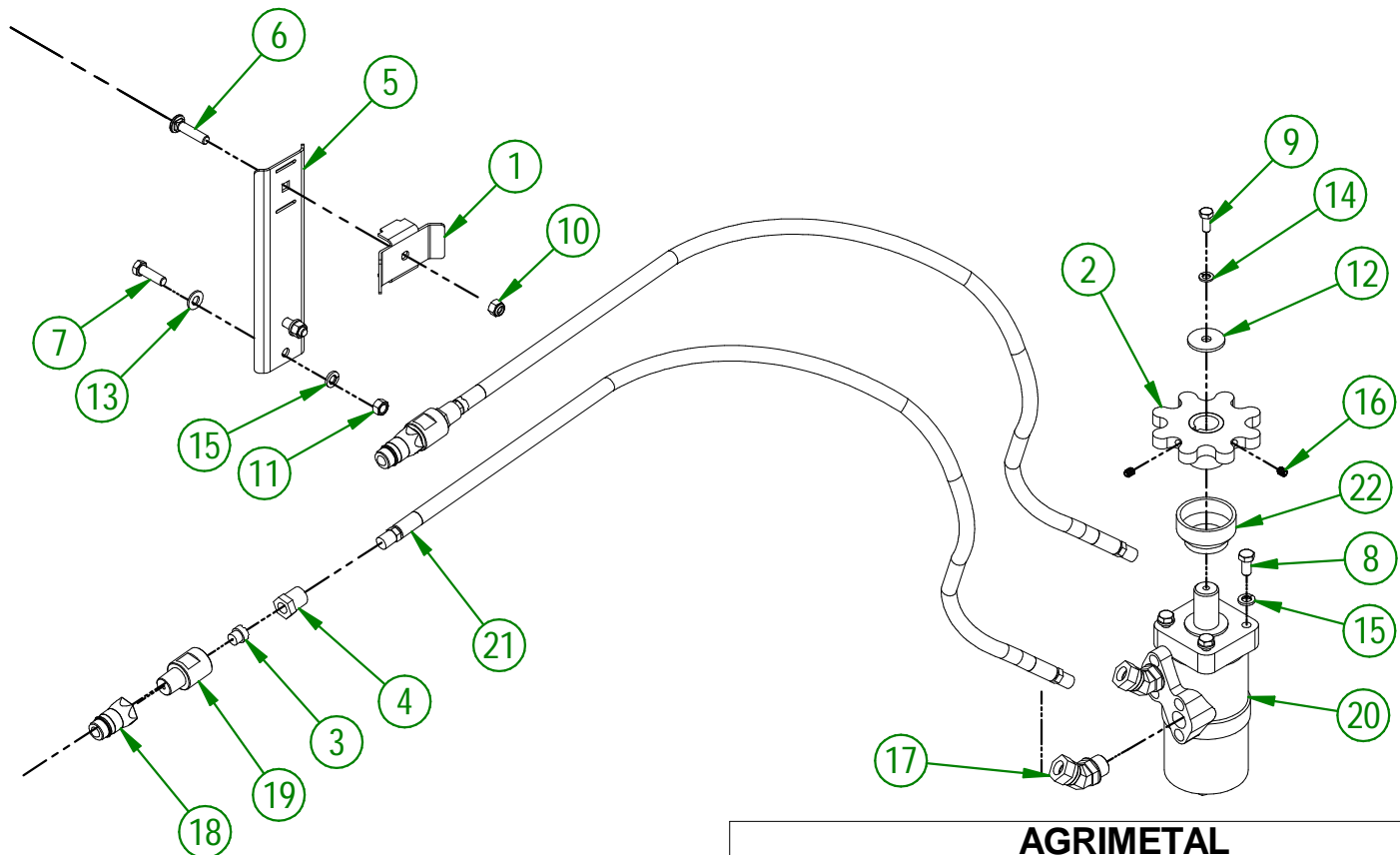

**AGRIMETAL**  
**HYDRAULIC MOTOR GROUP**

CREATION : 05/12/17  
REVISION : 25/03/26

ASSEMBLY : **81-57-5045**  
AUTHOR : F.HÉLIE

#	PART #	Qty	TITLE
1	83-55-0010	1	GEAR BOX ASSY.
2	81-57-0040	1	PTO GUARD
3	83-21-0000	4	TRANSMISSION BUSHING
4	83-41-0900	1	IMPELLER KEY
5	NC02-22-0013	6	WASHER ZINC 5/8 ID X 1 1/2 OD
6	NC02-32-0016	8	LOCK WASHER ZINC 5/8"
7	NC01-33-0394	4	HEX. BOLT GR8 NC ZINC 5/8-11 X 1 1/2" LG.
8	NC01-33-0400	4	CAP SCREW GR8 NC ZINC 5/8-11 X 3" LG
9	80-41-0135	1	PTO GUARD STEEL CABLE
10	NC01-64-0005	2	OVAL SLEEVE (ALUMINUM)
11	NCI3-25-0019	1	BLACK TIE RAP
12	NCI3-50-0110	1	IMPORTANT/NOTICE PTO POSTER
13	83-34-0030	1	PTO SHAFT T90
14	NC01-63-0027	1	HAIRPIN COTTER
15	83-01-0170	1	PTO GUARD SUPPORT
16	80-04-0485	1	GEARBOX BRACE
17	80-04-0480	1	GEARBOX BRACE
18	NC02-25-0011	8	WASHER SAE ZINC 17/32 ID
19	NC02-32-0014	4	LOCK WASHER ZINC 1/2"
20	NC02-07-0020	4	HEX. NUT ZINC 1/2-13
21	NC01-33-0249	4	CAP SCREW GR8 NC ZINC 1/2-13 X 1 1/2" LG

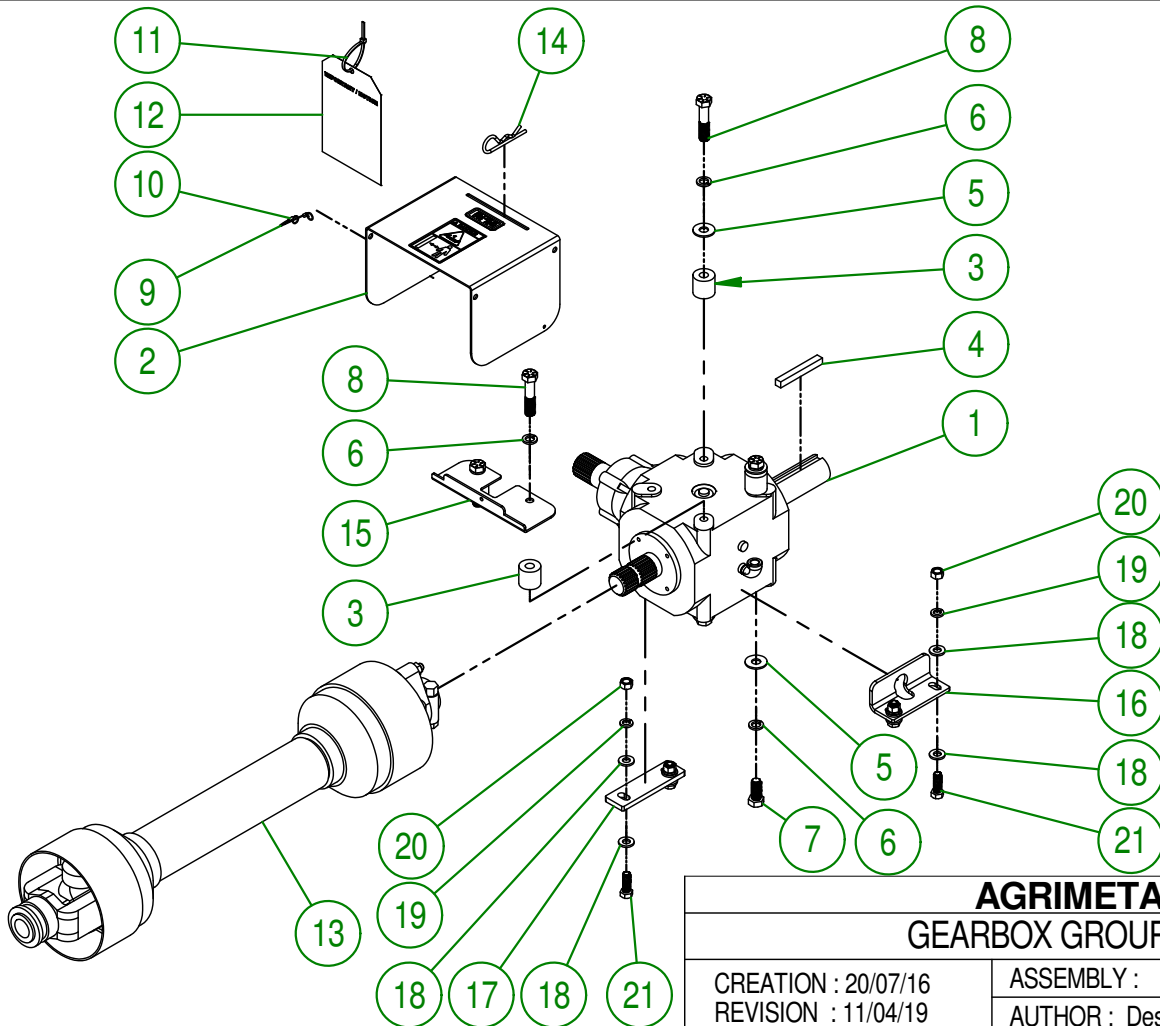

**AGRIMETAL**  
GEARBOX GROUPING

CREATION : 20/07/16  
REVISION : 11/04/19

ASSEMBLY : **83-57-0430**

AUTHOR : Dessin2 Page 13 de 23

#	PART #	Qty	TITLE
1	83-50-5000	1	IMPELLER
2	80-04-0185	1	WASHER
3	NC02-32-0016	1	LOCK WASHER ZINC 5/8"
4	NC01-25-0395	1	HEX. BOLT GR5 ZINC 5/8-11 X 1 3/4" LG
5	NC01-37-0259	2	HEX. BOLT GR8 NF ZINC 1/2-20 X 4" LG
6	NC01-94-0013	2	NYLON NUT ZINC 1/2-20"
7	NC01-69-0791	1	GREASE FITTING 1/8 NPT STRAIGHT
8	NC01-21-0463	2	HEX. BOLT GR2 ZINC 3/4-16 X 1" LG

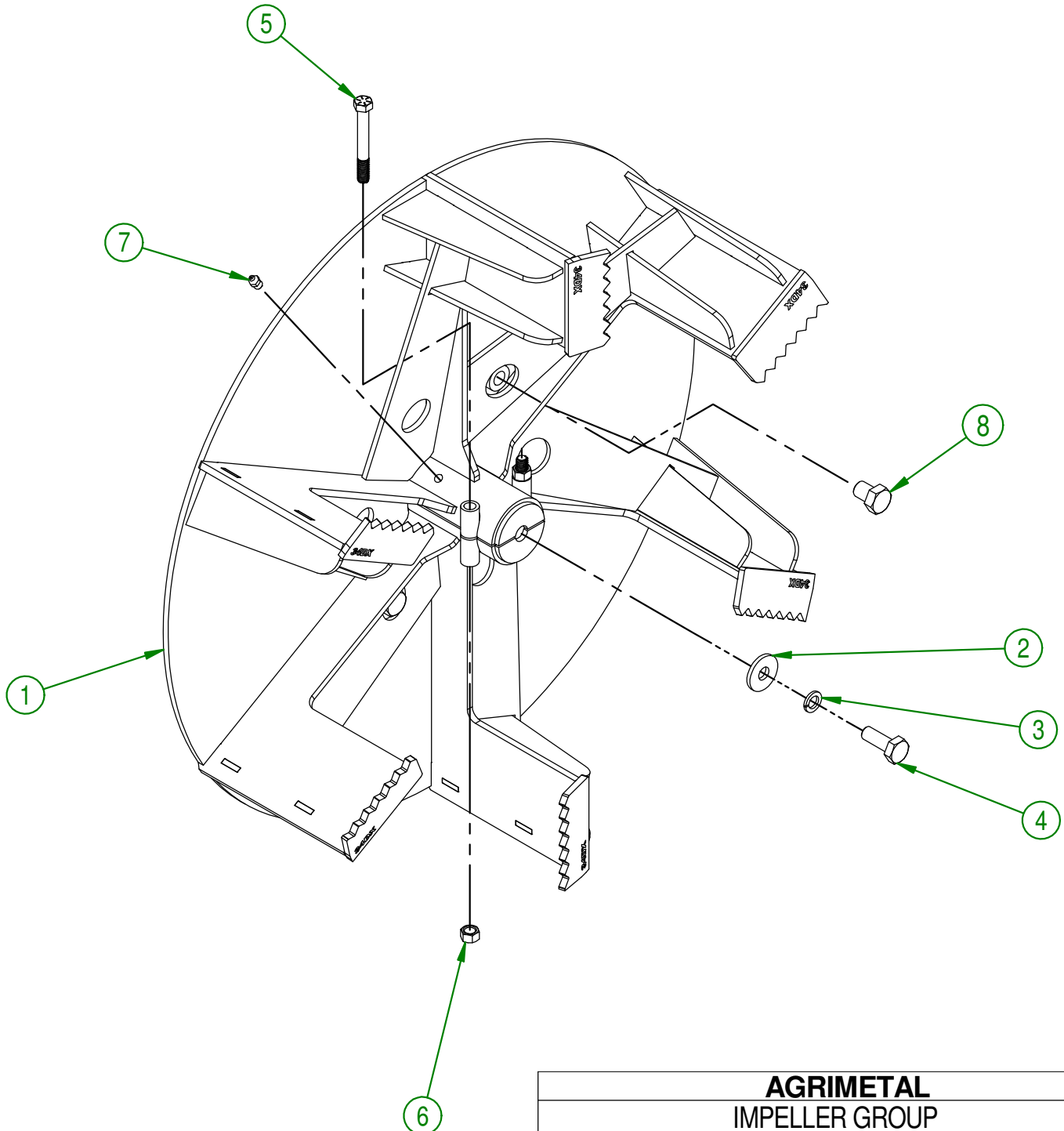

**AGRIMETAL**  
**IMPELLER GROUP**

CREATION : 16/05/19  
 REVISION : 06/11/19

ASSEMBLY : **83-57-5025**  
 AUTHOR : F.HÉLIE | Page 14 de 23

#	PART #	Qty	TITLE
1	83-50-5025	1	LEFT SNOW GUARD
2	83-50-5030	1	RIGHT SNOW GUARD
3	NC02-32-0014	6	LOCK WASHER ZINC 1/2"
4	NC01-25-0249	5	HEX. BOLT GR5 ZINC 1/2-13 X 1 1/2" LG
5	NC01-25-0247	1	HEX. BOLT GR5 ZINC 1/2-13 X 1" LG

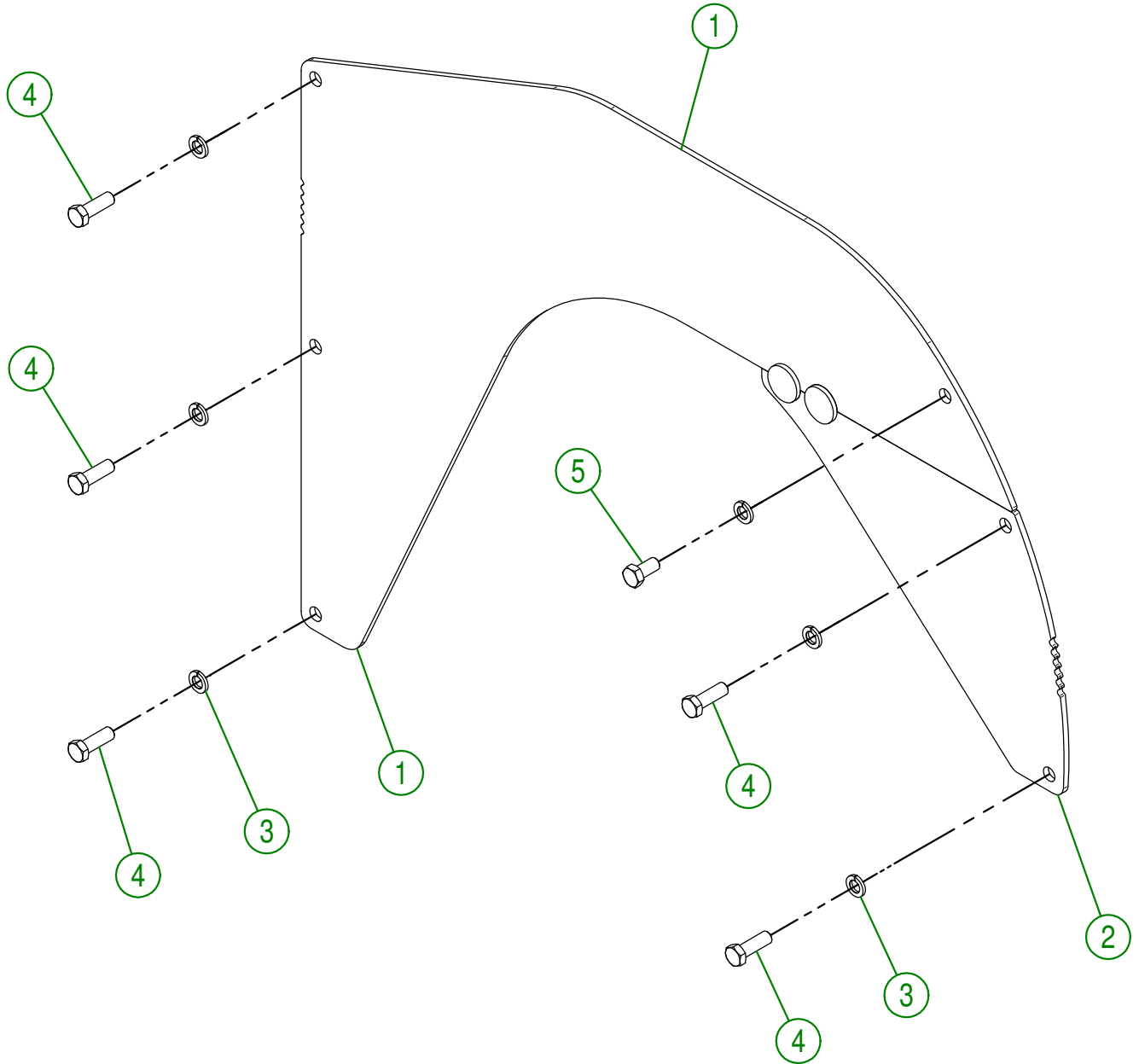

<b>AGRIMETAL</b>	
<b>SNOW GUARD GROUP</b>	
CREATION : 28/05/18	ASSEMBLY : <b>83-57-5010</b>
REVISION : 17/10/18	AUTHOR : J. Houle Page 15 de 23

#	PART #	Qty	TITLE
1	NC14-75-0161	2	FLANGE BEARING UCF 208-24 1 1/2" ID
2	81-50-1530	1	SPIRAL
3	NC02-32-0016	8	LOCK WASHER ZINC 5/8"
4	NC02-07-0022	8	HEX. NUT ZINC 5/8-11
5	NC02-25-0013	8	WASHER ZINC SAE ZINC 21/32 ID
6	NC01-17-0396	4	HEX. BOLT GR2 ZINC 5/8-11 X 2"
7	NC01-17-0395	4	HEX. BOLT GR2 ZINC 5/8-11 X 1 3/4"
8	NC14-55-0275	1	SPROCKET 80A34 X 1 1/2"
9	NC01-29-0249	4	HEX. BOLT GR2 NC ZINC 1/2-20 X 1 1/2"
10	NC01-94-0013	4	HEX. LOCK NUT NF ZINC 1/2-20
11	81-51-0085	1	SHAFT OF THE SPIRAL
12	81-50-0150	1	SHAFT OF THE SPIRAL (SPROCKET)

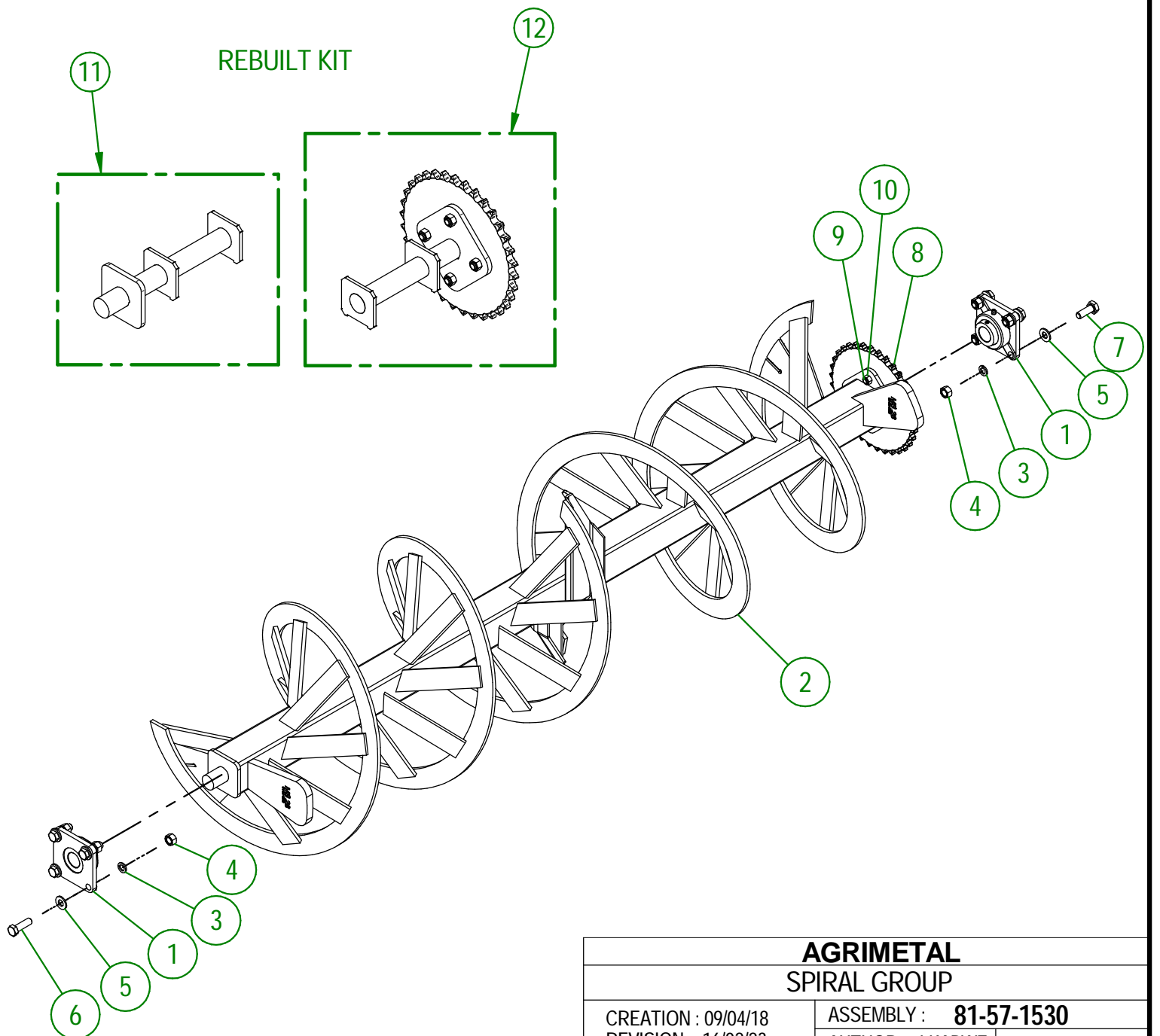

**AGRIMETAL**  
**SPIRAL GROUP**

CREATION : 09/04/18  
 REVISION : 16/02/23

ASSEMBLY : **81-57-1530**  
 AUTHOR : J.KABWE

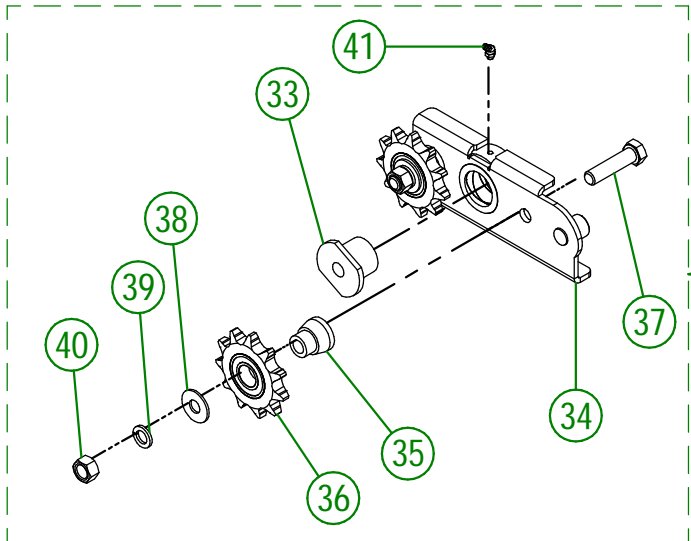
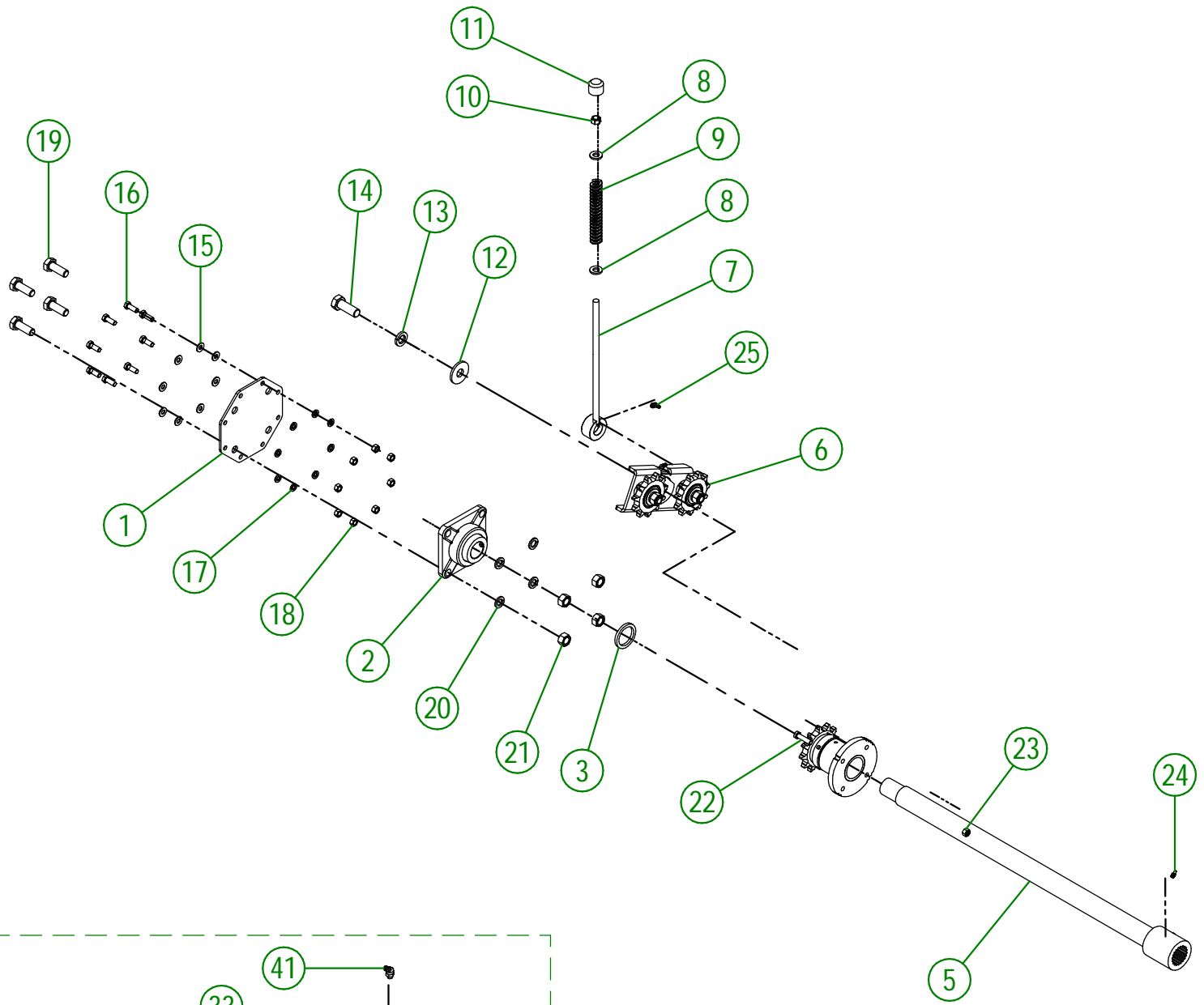

<b>AGRIMETAL</b>	
<b>SPIRAL DRIVE TRAIN GROUP</b>	
CREATION : 28/05/18	ASSEMBLY : <b>83-57-5045</b>
REVISION : 15/07/22	AUTHOR : J. Houle

## 83-57-5045

#	PART #	Qty	TITLE
1	81-04-0010	1	BEARING SUPPORT
2	NC14-75-0025	1	FLANGE BEARING 4 HOLES UCF 208-24 X 1 1/2"
3	81-21-0010	1	SPIRAL DRIVE TRAIN BUSHING
4*	83-50-7016	1	SPROCKET (80A12H)
5	83-50-0566	1	SPIRAL DRIVE TRAIN
6	81-55-0400	1	CHAIN TENSIONER GROUP
7	83-50-5071	1	CHAIN TENSIONER THREADED ROD
8	NC02-25-0011	2	WASHER SAE ZINC 17/32 ID
9	NC13-86-0341	1	GREEN SPRING 1/2" ID X 1" OD X 6" LG
10	NC01-96-0014	1	NYLON-INSERT LOCKNUT ZINC 1/2-13
11	80-42-0110	1	THREADED ROD CAP
12	81-04-0135	1	WASHER 2.015" DIA. X 49/64"
13	NC02-32-0017	1	LOCK WASHER ZINC 3/4"
14	NC01-17-0467	1	HEX. BOLT GR2 ZINC 3/4-10 X 2"
15	01-01-2485	8	FLAT WASHER 14 GA X 13/16"OD X 25/64" ID
16	NC01-17-0114	8	HEX. BOLT GR2 ZINC 3/8-16 X 1"
17	NC02-32-0012	8	LOCK WASHER ZINC 3/8"
18	NC02-07-0018	8	HEX. NUT ZINC 3/8-16
19	NC01-17-0395	4	HEX. BOLT GR2 ZINC 5/8-11 X 1 3/4"
20	NC02-32-0016	6	LOCK WASHER ZINC 5/8"
21	NC02-07-0022	4	HEX. NUT ZINC 5/8-11
22	NC01-25-0116	1	HEX. BOLT GR5 ZINC 3/8-16 X 1 1/2"
23	NC01-93-0011	1	LOCK NUT 3/8-16
24	NC01-69-0785	1	STRAIGHT GREASE FITTING 1/4-28
25	NC01-69-0787	1	GREASE FITTING STRAIGHT 1/4-28 X 90
26	83-37-0011	1	#80 HD CHAIN
27	81-55-0005	2	CHAIN TENSIONER SPROCKET
28	NC02-22-0013	2	WASHER ZINC 5/8 ID X 1 1/2 OD
29	NC02-10-0022	2	HEX. NUT ZINC 5/8-18
30	83-21-0010	2	CHAIN TENSIONER BUSHING
31*	80-04-0185	2	WASHER
32	NC01-17-0404	2	HEX. BOLT GR2 ZINC 5/8-11 X 3 1/2"

## 81-55-0400

#	PART #	Qty	TITLE
33	88-13-0005	1	CHAIN TENSIONER BUSHING
34	81-50-5005	1	CHAIN TENSIONER
35	81-21-0020	2	CHAIN TENSIONER BUSHING
36	81-55-0005	2	CHAIN TENSIONER SPROCKET
37	NC01-17-0398	2	HEX. BOLT GR2 NC ZINC 5/8-11 X 2 1/2"
38	NC02-22-0013	2	WASHER ZINC 5/8 ID X 1 1/2 OD
39	NC02-32-0016	2	LOCK WASHER ZINC 5/8"
40	NC02-10-0022	2	HEX. NUT ZINC 5/8-18
41	NC01-69-0786	1	GREASE FITTING 1/4-28 X 45

#	PART #	Qty	TITLE
1	83-50-5010	1	CHAIN GUARD
2	NC01-04-0107	10	CARR. BOLT GR2 ZINC 3/8-16 X 3/4"
3	NC02-14-0019	10	FLANGE NUT HEX. NC 3/8-16 GR. B
4	83-01-0085	1	GUARD OF HOLE
5	83-01-0087	1	PLATE
6	NC01-17-0247	4	HEX. BOLT GR2 ZINC 1/2-13 X 1"
7	NC02-32-0014	4	LOCK WASHER ZINC 1/2"
8	NC02-07-0020	4	HEX. NUT ZINC 1/2-13

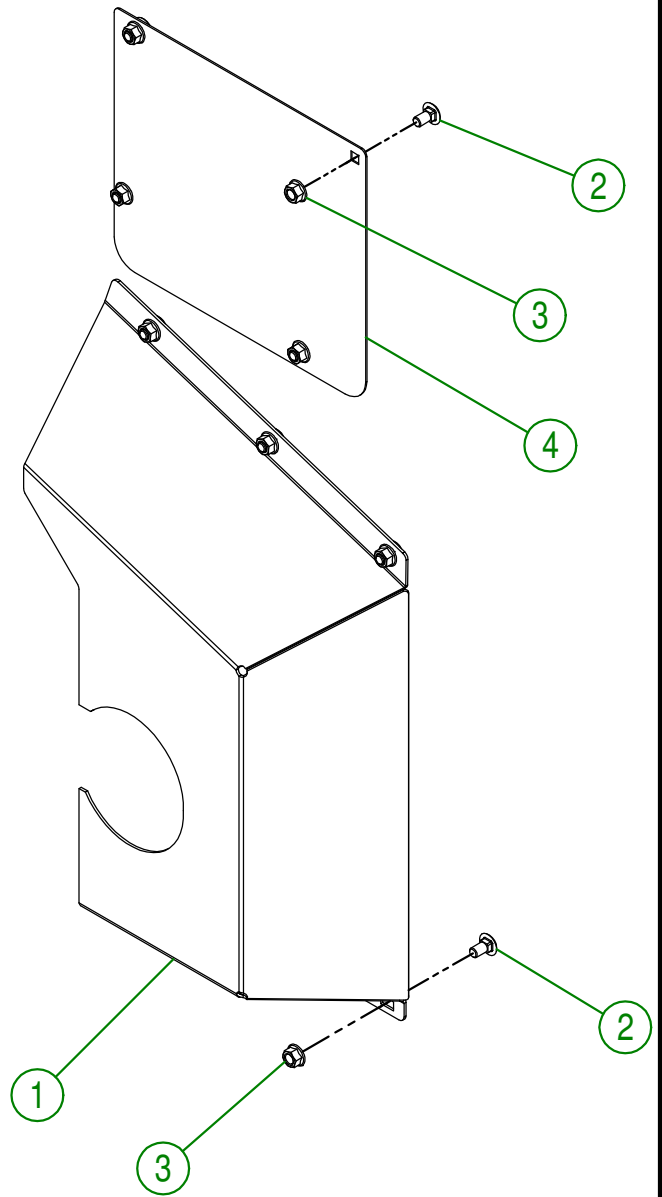
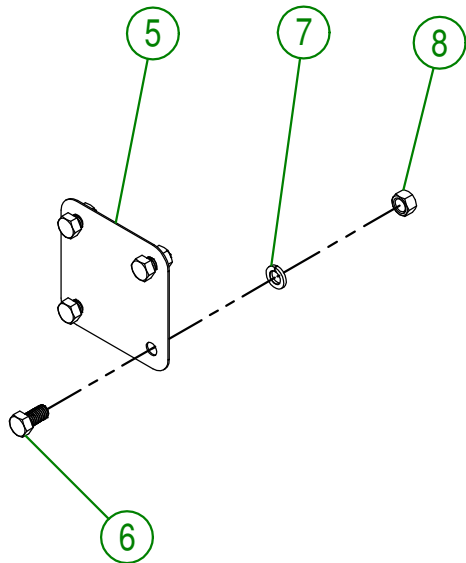

<b>AGRIMETAL</b>	
<b>CHAIN GUARD GROUP</b>	
CREATION : 28/05/18	ASSEMBLY : <b>83-57-5020</b>
REVISION : 18/10/18	AUTHOR : J. Houle Page 19 de 23

#	PART #	Qty	TITLE
1	83-57-5005	1	CHAIN GUARD
2	NC02-26-1525	4	WASHER INOX .406" D.I. X .815" D.E.
3	NC01-17-0114	2	HEX. BOLT GR2 ZINC 3/8-16 X 1"
4	NC01-96-0011	2	NYLON NUT 3/8-16

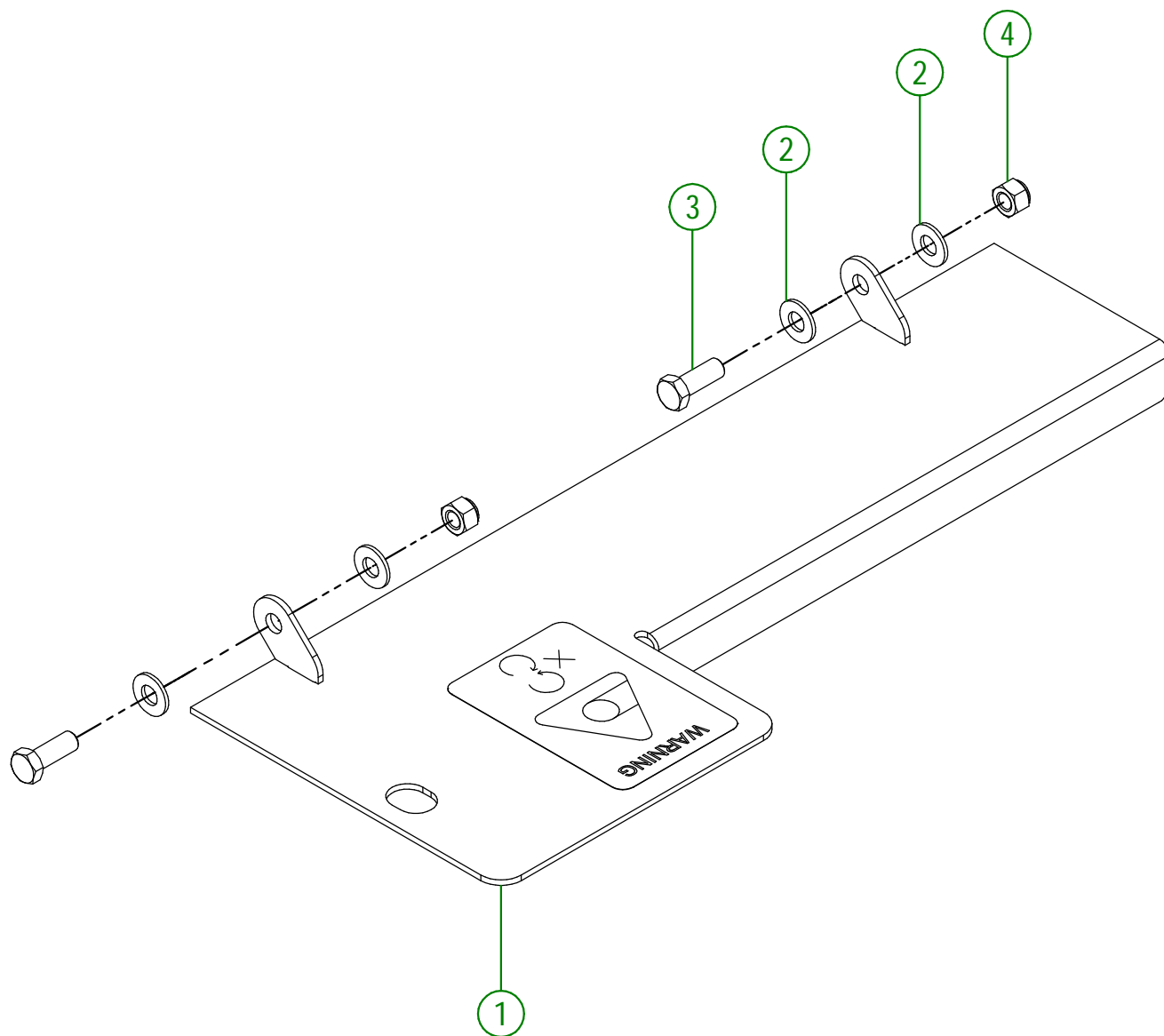

<b>AGRIMETAL</b>	
<b>CHAIN GUARD GROUP</b>	
CREATION : 28/05/18	ASSEMBLY : <b>83-57-5015</b>
REVISION : 22/12/25	AUTHOR : J. Houle

#	PART #	Qty	TITLE
1	NCI3-30-0237	1	PLASTIC TUBE FOR OPERATOR'S MANUAL
2	NC02-25-0007	2	WASHER ZINC 0.281 = 9/32
3	NC01-17-0007	2	HEX. BOLT GR2 ZINC 1/4-20 X 1 1/4"
4	NC01-96-0009	2	NYLON-INSERT LOCKNUT ZINC 1/4-20
5	81-57-0030	1	SET OF 6 SHEAR BOLT WITH NUT
6	81-98-0521	1	ENGLISH OPERATOR'S MANUAL (MS28 & 30)

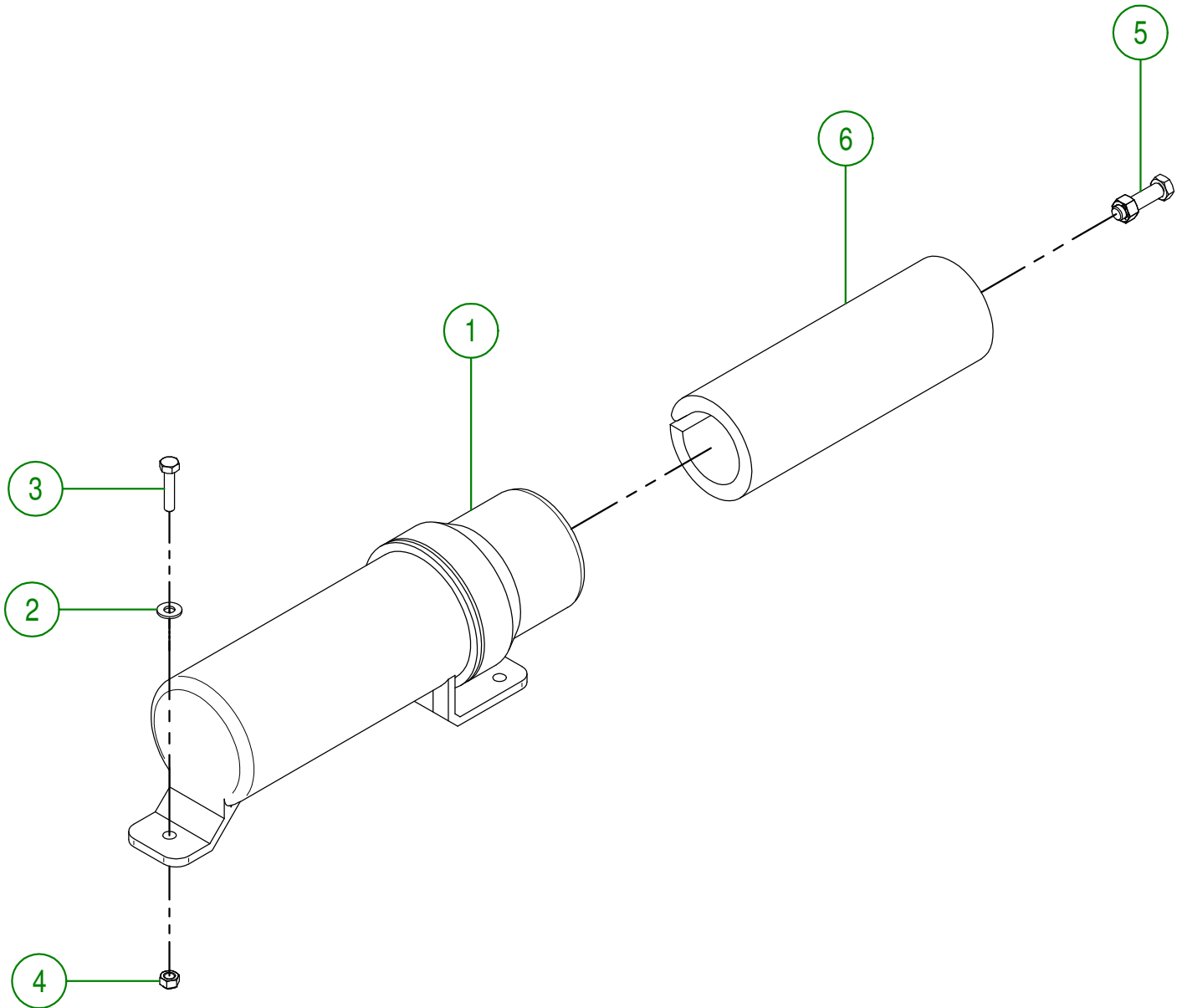

<b>AGRIMETAL</b>	
<b>OPERATOR'S MANUAL TUBE GROUP</b>	
CREATION : 19/07/16	ASSEMBLY : <b>81-57-0400</b>
REVISION : 08/05/18	AUTHOR : J. HOULE   Page 21 de 23

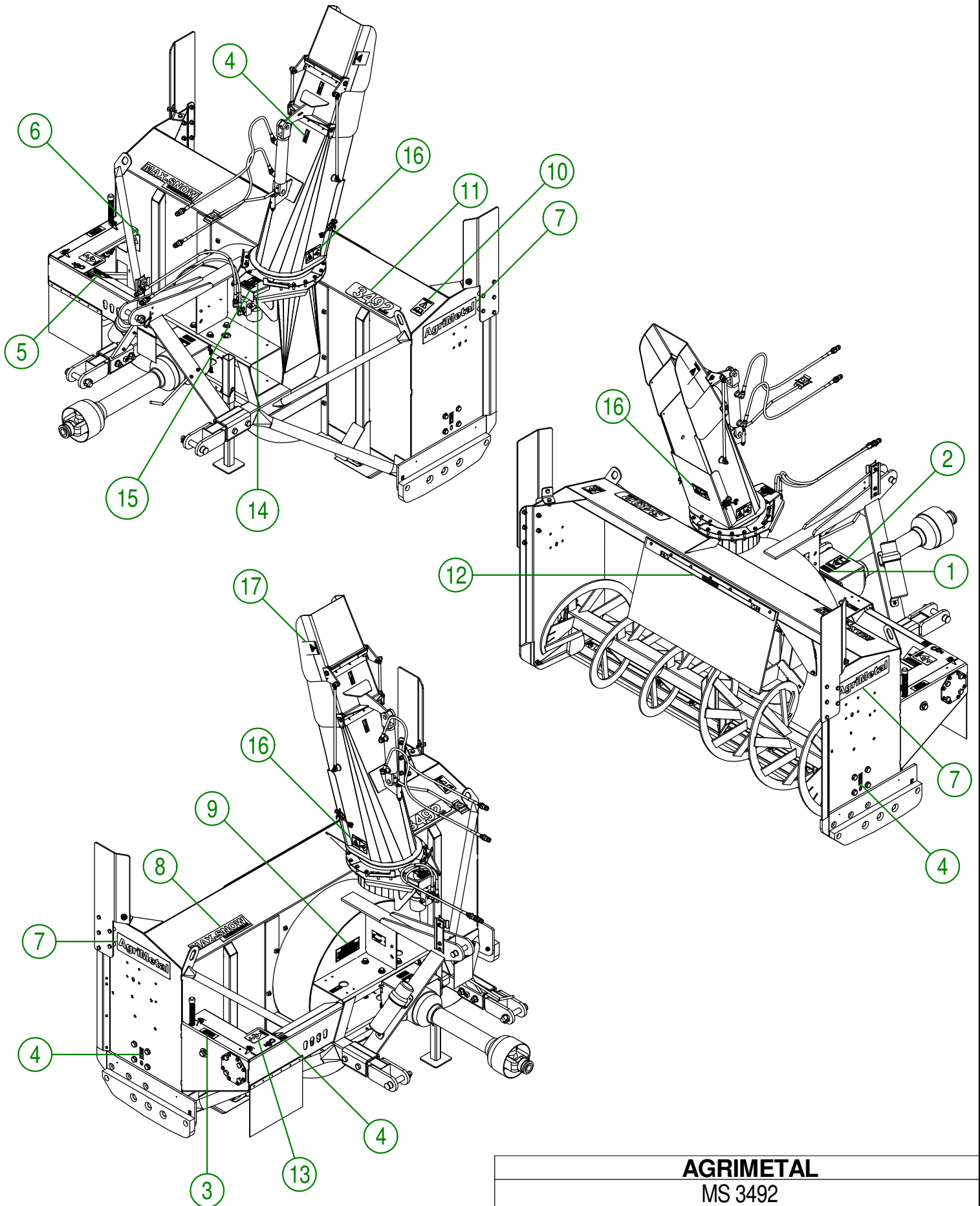

## AGRIMETAL

MS 3492

CREATION : 17/10/18  
REVISION : 11/03/19

ASSEMBLY : **83-99-5000**

AUTHOR : J.KABWE Page 22 de 23

#	PART #	Qty	TITLE
1	NC13-33-0005	1	STICKER MAXIMUM 540 RPM
2	NC13-33-0187	1	STICKER DANGER (PTO AND PERSON)
3	NC13-33-0248	1	STICKER IMPORTANT 4 1/4 INCHES 110mm
4	NC13-33-0024	6	STICKER GREASE HERE
5	NC13-33-0281	1	STICKER SHEAR BOLT
6	NC13-33-0189	1	STICKER DANGER (PERSON AND CHAIN DRIVE)
7	NC13-33-0001	2	STICKER AGRIMETAL
8	NC13-33-0241	1	STICKER MAX-SNOW COMMERCIAL
9	NC13-33-0317	1	STICKER GREASE DRIVE LINE TELESCOPIC SHAFT
10	NC13-33-0183	1	STICKER CAUTION OPERATION MANUAL
11	NC13-33-0320	1	STICKER 3492
12	NC13-33-0274	1	STICKER DANGER
13	NC13-33-0283	1	STICKER DANGER (PERSON AND CHAIN DRIVE)
14	NC13-33-0326	1	STICKER DANGER (HAND)
15	NC13-33-0327	1	STICKER END ROTATION ADJUSTMENT
16	NC13-33-0249	3	STICKER DANGER
17	NC13-33-0192	2	STICKER (PROJECTION RISK)