

AgriMetal

PARTS LIST

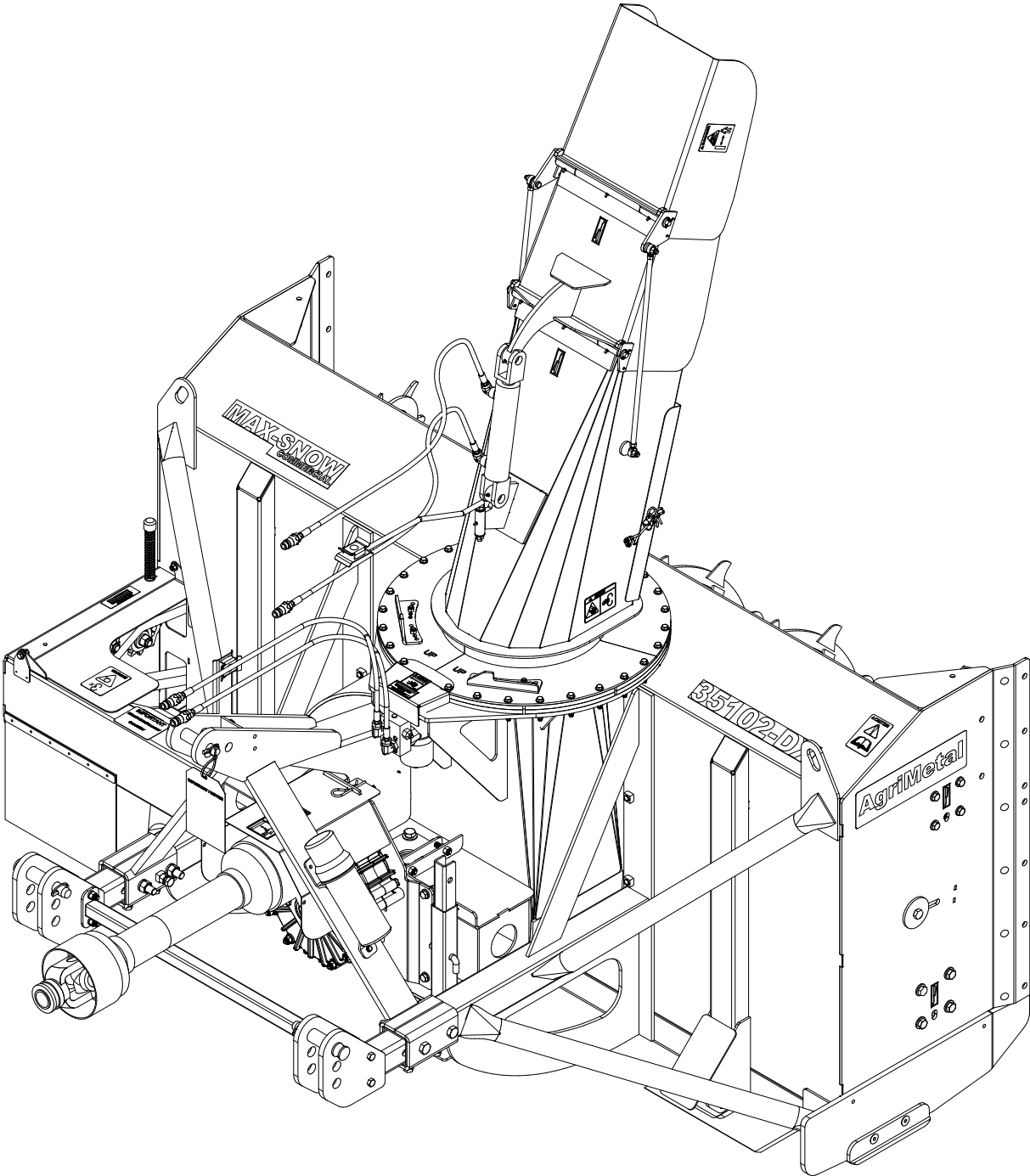

MS 35102-DX

88-57-0055

#	PART #	Qty	TITLE
1	88-50-0115	2	LATERAL SKATE (#450 HARDNESS STEEL)
2	88-50-0050	2	ADJUSTABLE SKATE (STAINLESS STEEL)
3	NC02-48-0586	4	FLAT HEAD SOCKET CAP SCREW 5/8-11 X 1" LG
4	88-57-0120	2	KNIFE (#450 HARDNESS STEEL)

88-57-0120

#	PART #	Qty	TITLE
5	88-20-0075	1	KNIFE (#450 HARDNESS STEEL)
6	NC01-09-0039	6	PLOW BOLT GR5 5/8-11 X 1 1/2" LG
7	NC01-93-0016	6	LOCK NUT ZINC 5/8-11

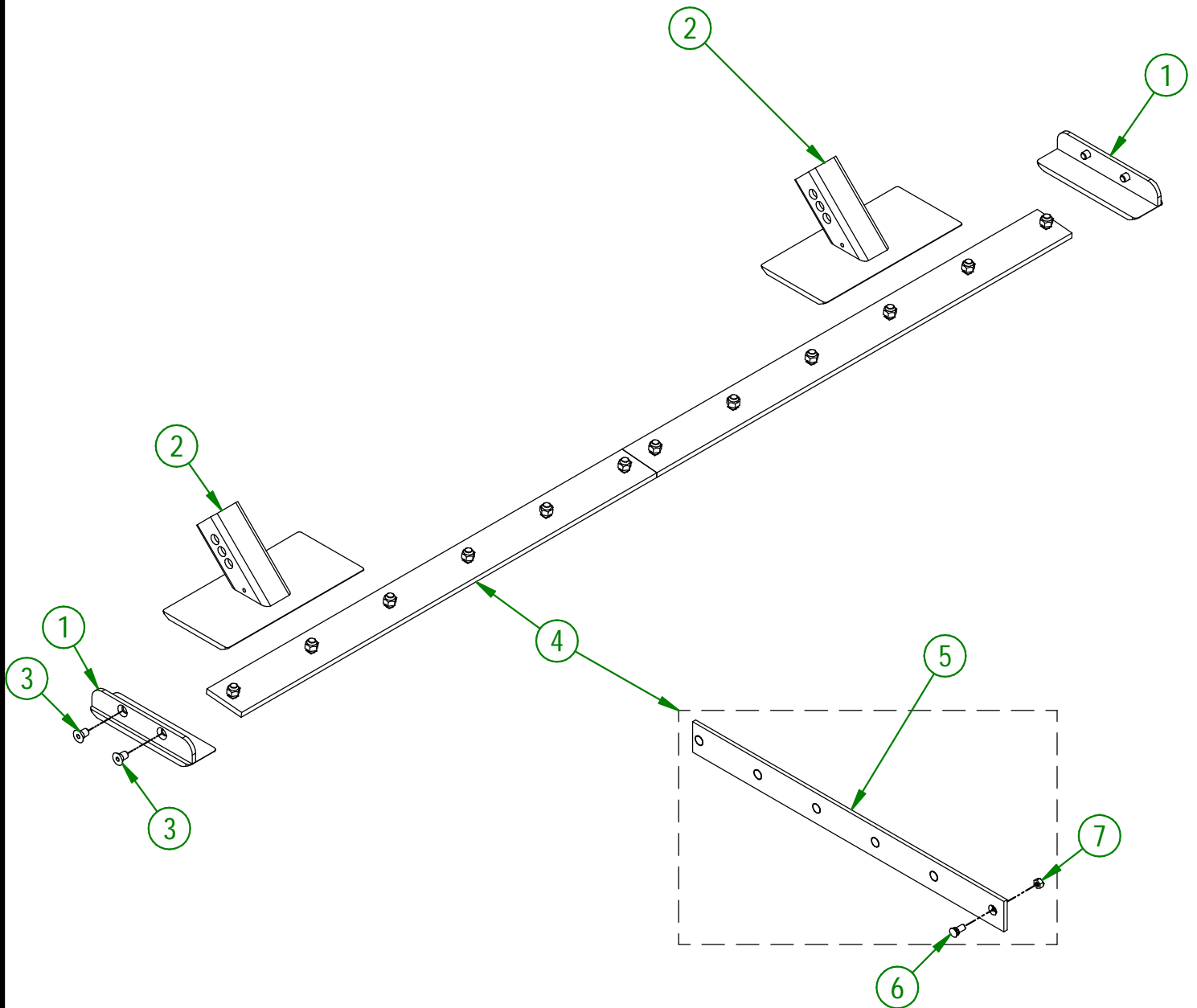

AGRIMETAL	
SET OF KNIVES (#450 HARDNESS STEEL)	
CREATION : 27/05/19	ASSEMBLY : 88-57-0055
REVISION : 26/09/23	AUTHOR : F.HÉLIE

#	PART #	Qty	TITLE
1	88-20-0080	1	LATERAL CUTTER BLADE (LEFT)
2	88-20-0085	1	LATERAL CUTTER BLADE (RIGHT)
3	88-20-0087	1	LATERAL CUTTER BLADE (LEFT)
4	88-20-0083	1	LATERAL CUTTER BLADE (RIGHT)
5	NC01-04-0266	14	BOLT CARR. GR2 ZINC 5/8-11 X 2"
6	NC02-22-0013	18	WASHER ZINC 5/8 ID X 1 1/2 OD
7	NC02-32-0016	18	LOCK WASHER ZINC 5/8"
8	NC02-07-0022	18	HEX. NUT ZINC 5/8-11
9	NC01-04-0270	4	CARR. BOLT GR2 ZINC 5/8 - 11 X 2 1/2"
10	88-10-0015	4	LATERAL CUTTER BLADE BUSHING
11	81-04-0525	2	LATERAL KNIFE REINFORCE
12	NC01-25-0248	4	HEX. BOLT GR5 ZINC 1/2-13 X 1 1/4"
13	NC02-32-0014	4	LOCK WASHER ZINC 1/2"
14	NC02-07-0020	4	HEX. NUT ZINC 1/2-13

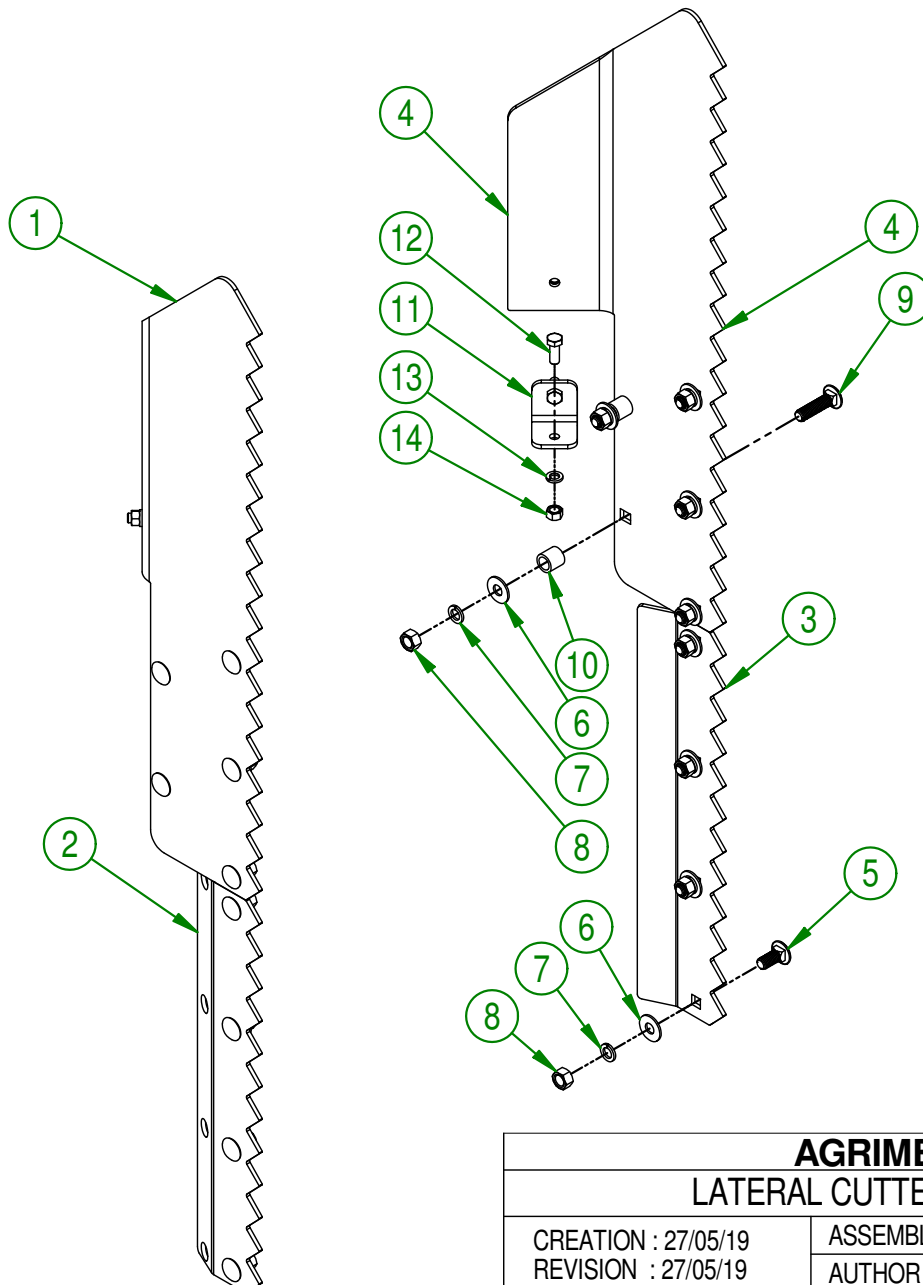

AGRIMETAL	
LATERAL CUTTER BLADES	
CREATION : 27/05/19	ASSEMBLY : 88-57-0065
REVISION : 27/05/19	AUTHOR : F.HÉLIE Page 2 de 19

88-57-0075

#	PART #	Qty	TITLE
1	88-50-0055	1	SNOW DEFLECTOR
2	NC01-04-0110	6	CARR. BOLT GR2 ZINC 3/8-16 X 1 1/4"
3	21-01-0950	6	FLAT WASHER IOGA 1.005" DIA X 25/64"
4	NC02-32-0012	6	LOCK WASHER ZINC 3/8"
5	NC02-07-0018	6	HEX. NUT ZINC 3/8-16

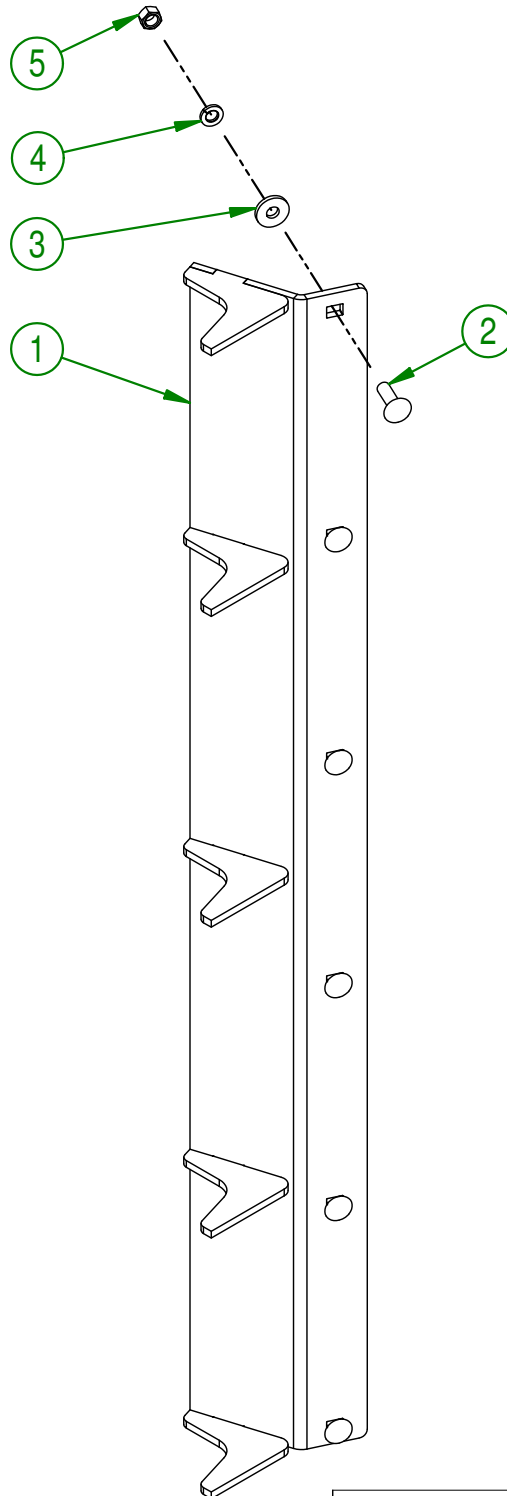

AGRIMETAL	
SNOW DEFLECTOR GROUP	
CREATION : 27/05/19	ASSEMBLY : 88-57-0075
REVISION : 27/05/19	AUTHOR : F.HÉLIE Page 3 de 19

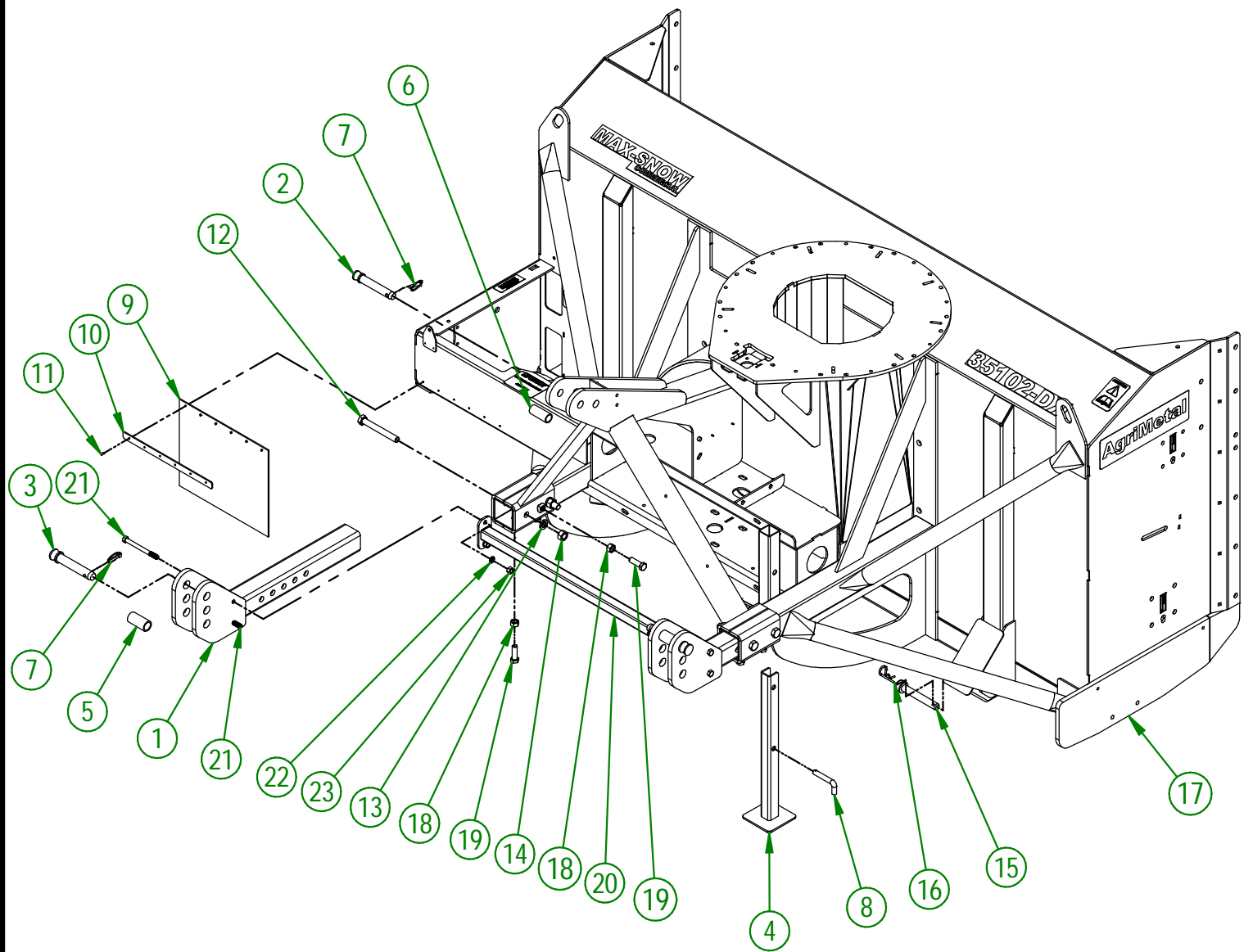

AGRIMETAL
FRAME GROUP

CREATION : 24/05/19
 REVISION : 06/01/26

ASSEMBLY : **88-57-0002**
 AUTHOR : F.HÉLIE

88-57-0002

#	PART #	Qty	TITLE
1	81-50-5040	2	ATTACHMENT HAND
2	48-20-0060	1	3 POINT PIN
3	48-20-0065	2	3 POINT PIN
4	88-50-0060	1	STAND
5	88-09-0035	2	(CAT.3) 3 POINTS BOTTOM BUSHING
6	88-09-0040	1	(CAT,3) 3 POINTS TOP BUSHING
7	NC01-69-1100	3	LINCH PIN 3/8"
8	NC01-69-1310	1	BENT CLEVIS 5/8" X 3" WITH "R" PIN
9	NC13-15-0300	1	SNOW GUARD
10	80-01-1075	1	SNOW GUARD BRACE
11	NC01-78-0041	6	POP RIVET STAINLESS STEEL ROD STEEL .187" X .690"
12	NC01-33-0482	4	HEX. BOLT GR8 ZINC 3/4-10 X 6"
13	NC02-32-0017	4	LOCK WASHER ZINC 3/4"
14	NC02-07-0023	4	HEX. NUT ZINC 3/4-10
15	88-20-0095	2	ADJUSTABLE SKATE PIN
16	NC01-63-0027	2	HAIRPIN COTTER
17	88-57-0072	1	FRAME (STICKER INCLUDED)
18	NC02-07-0022	6	HEX. NUT ZINC 5/8-11
19	NC01-17-0396	6	HEX. BOLT GR2 ZINC 5/8-11 X 2"
20	88-50-0140	1	ATTACHMENT HAND BRACE
21	NC01-25-0265	4	HEX. BOLT GR5 ZINC 1/2-13 X 5 1/2"
22	NC02-32-0014	4	LOCK WASHER ZINC 1/2"
23	NC02-07-0020	4	HEX. NUT ZINC 1/2-13

AGRIMETAL

REGROUPEMENT DE CHASSIS

CREATION : 24/05/19
 REVISION : 06/01/26

ASSEMBLY : **88-57-0002**
 AUTHOR : F.HÉLIE

#	PART #	Qty	TITLE
1	88-50-0031	1	SNOW GUARD (LEFT)
2	88-50-0035	1	SNOW GUARD (RIGHT)
3	NC02-32-0016	8	LOCK WASHER ZINC 5/8"
4	NC01-17-0394	8	HEX. BOLT GR2 ZINC 5/8-11 X 1 1/2"

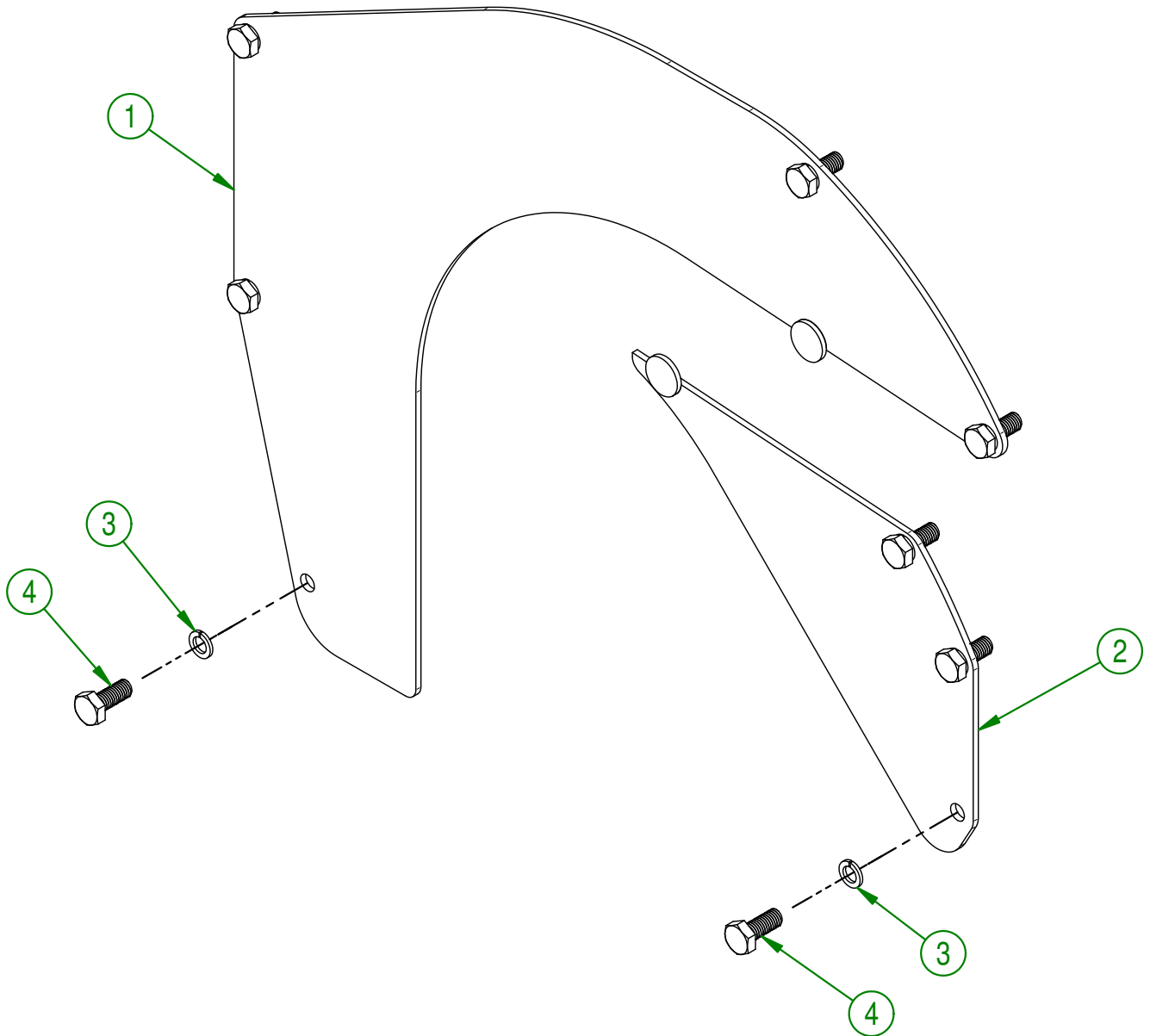

AGRIMETAL	
SNOW GUARD GROUP	
CREATION : 27/05/19	ASSEMBLY : 88-57-0051
REVISION : 27/05/19	AUTHOR : F.HÉLIE
	Page 6 de 19

#	PART #	Qty	TITLE
1	88-50-0005	1	IMPELLER
2	80-04-0185	1	WASHER
3	NC02-32-0016	1	LOCK WASHER ZINC 5/8"
4	NC01-25-0395	1	HEX. BOLT GR5 ZINC 5/8-11 X 1 3/4" LG
5	NC01-37-0259	2	HEX. BOLT GR8 NF ZINC 1/2-20 X 4" LG
6	NC01-94-0013	2	NYLON NUT ZINC 1/2-20"
7	NC01-69-0791	1	GREASE FITTING 1/8 NPT STRAIGHT
8	NC01-21-0463	2	HEX. BOLT GR2 ZINC 3/4-16 X 1" LG

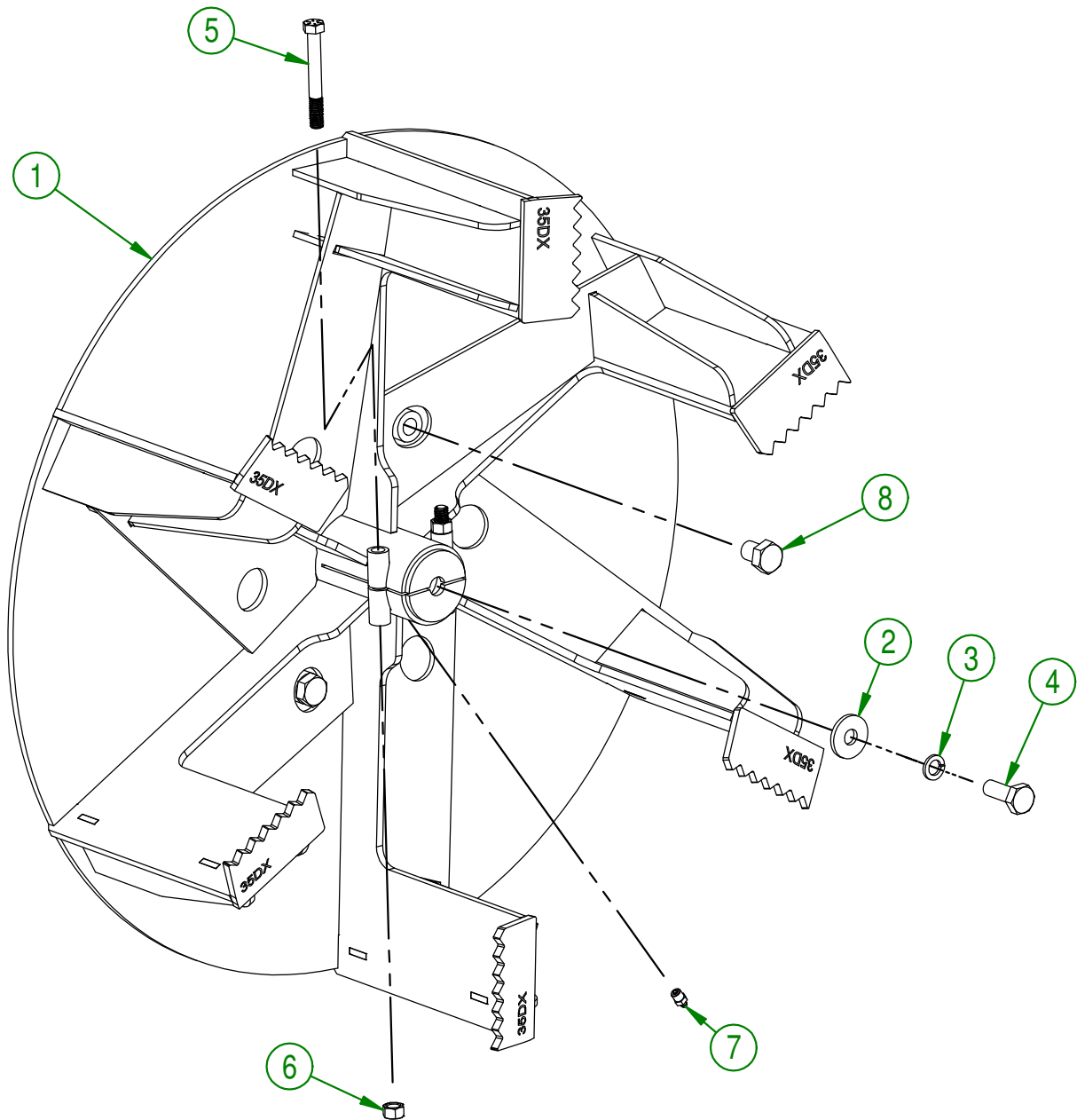

AGRIMETAL
IMPELLER GROUP

CREATION : 24/05/19
 REVISION : 06/11/19

ASSEMBLY : **88-57-0015**

AUTHOR : F.HÉLIE

Page 7 de 19

#	PART #	Qty	TITLE
1	NC14-75-0165	2	FLANGE BEARING 4 HOLES UCF 209-28 X I 3/4"
2	NC14-75-0160	2	FLANGE BEARING 4 HOLES UCF 207-20 X I 1/4"
3	88-37-0000	1	#80 HD CHAIN X 80"
4	81-55-0005	1	CHAIN TENSIONER SPROCKET
5	83-04-0615	1	WASHER
6	NC01-29-0406	1	HEX. BOLT GR5 ZINC 5/8-18 X 4"
7	NC02-22-0013	1	WASHER ZINC 5/8 ID X I 1/2 OD
8	NC02-32-0016	9	LOCK WASHER ZINC 5/8"
9	NC02-10-0022	1	HEX. NUT ZINC 5/8-18
10	NC02-07-0020	10	HEX. NUT ZINC 1/2-13
11	88-50-0066	1	CHAIN TENSIONER
12	88-50-0092	1	SPIRAL
13	88-50-0097	1	SPIRAL
14	80-01-1525	3	SPIRAL SHIM
15	NC02-25-0013	8	WASHER ZINC SAE ZINC 21/32 ID
16	NC01-17-0396	8	HEX. BOLT GR2 ZINC 5/8-11 X 2"
17	NC02-07-0022	8	HEX. NUT ZINC 5/8-11
18	NC02-25-0011	8	WASHER SAE ZINC 17/32 ID
19	NC02-32-0014	8	LOCK WASHER ZINC 1/2"
20	NC01-17-0250	4	HEX. BOLT GR2 ZINC 1/2-13 X I 3/4"
21	NC01-17-0251	4	HEX. BOLT GR2 ZINC 1/2-13 X 2"

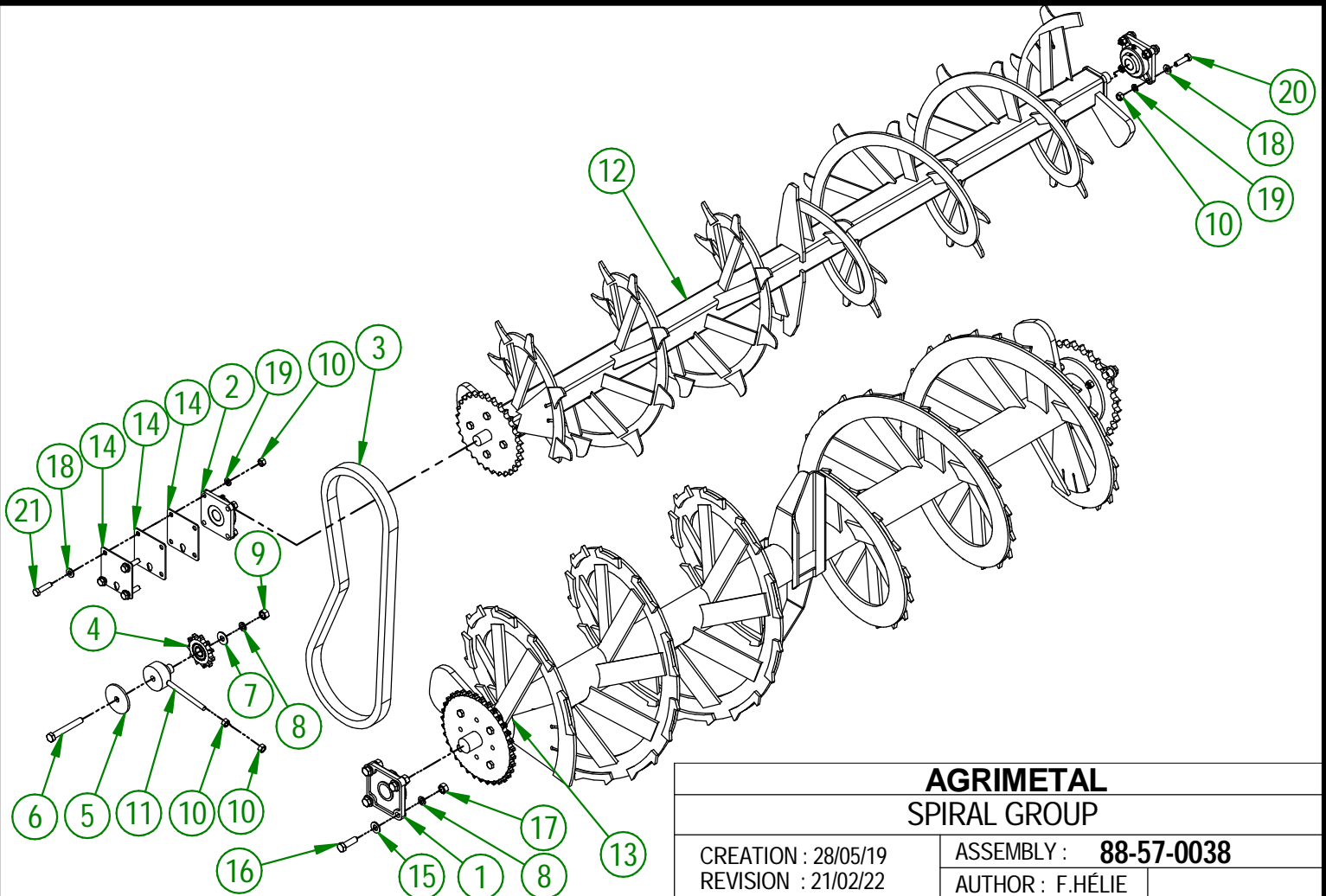

AGRIMETAL
SPIRAL GROUP

CREATION : 28/05/19
REVISION : 21/02/22

ASSEMBLY : **88-57-0038**
AUTHOR : F.HÉLIE

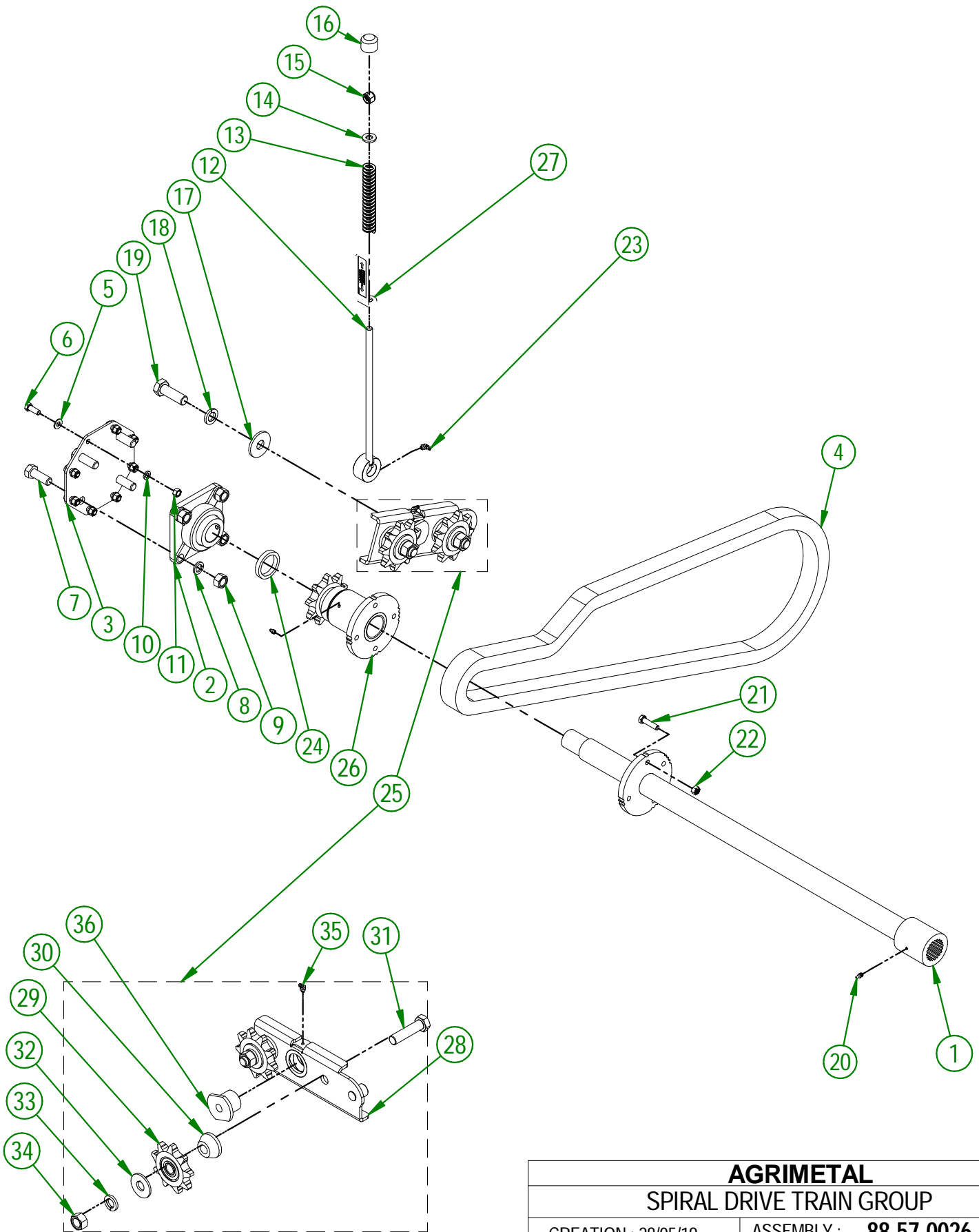

AGRIMETAL	
SPIRAL DRIVE TRAIN GROUP	
CREATION : 28/05/19	ASSEMBLY : 88-57-0026
REVISION : 23/12/25	AUTHOR : F.HÉLIE

88-57-0026

#	PART #	Qty	TITLE
1	88-50-0021	1	SPIRAL DRIVE TRAIN
2	NC14-75-0025	1	FLANGE BEARING 4 HOLES UCF 208-24 X 1 1/2"
3	81-04-0010	1	BEARING SUPPORT
4	88-37-0006	1	#100 HD CHAIN X 87 1/2"
5	NC02-26-1525	8	WASHER INOX .406" D.I. X .815" D.E.
6	NC01-17-0114	8	HEX. BOLT GR2 ZINC 3/8-16 X 1"
7	NC01-17-0395	4	HEX. BOLT GR2 ZINC 5/8-11 X 1 3/4"
8	NC02-32-0016	4	LOCK WASHER ZINC 5/8"
9	NC02-07-0022	4	HEX. NUT ZINC 5/8-11
10	NC02-32-0012	8	LOCK WASHER ZINC 3/8"
11	NC02-07-0018	8	HEX. NUT ZINC 3/8-16
12	88-50-0046	1	CHAIN TENSIONER THREADED ROD
13	NC13-86-0054	1	BLUE SPRING 1/2" ID X 1" OD X 6" LG
14	NC02-25-0011	1	WASHER SAE ZINC 17/32 ID
15	NC01-96-0014	1	NYLON-INSERT LOCKNUT ZINC 1/2-13
16	80-42-0110	1	THREADED ROD CAP
17	80-04-0170	1	WASHER
18	NC02-32-0017	1	LOCK WASHER ZINC 3/4"
19	NC01-17-0468	1	HEX. BOLT GR2 ZINC 3/4-10 X 2 1/4" LG.
20	NC01-69-0785	2	STRAIGHT GREASE FITTING 1/4-28
21	NC01-25-0116	1	HEX. BOLT GR5 ZINC 3/8-16 X 1 1/2"
22	NC01-93-0011	1	LOCK NUT 3/8-16
23	NC01-69-0787	1	GREASE FITTING STRAIGHT 1/4-28 X 90
24	88-21-0001	1	SPIRAL DRIVE SPROCKET SHIM
25	88-55-0020	1	CHAIN TENSIONER GROUP
26	88-55-0030	1	SPIRAL DRIVE TRAIN SPROCKET
27	83-57-0160	1	ADJUSTEMENT INDICATOR

88-55-0020

#	PART #	Qty	TITLE
28	88-50-0040	1	CHAIN TENSIONER
29	NC14-55-0316	2	SPROCKET 100A9H X 6205-2RS X 3/4"
30	88-21-0010	2	TENSIONER BUSHING
31	NC01-17-0471	2	HEX BOLT GR2 NC ZINC 3/4-10 X 3" LG
32	NC02-22-0016	2	WASHER ZINC 3/4"
33	NC02-32-0017	2	LOCK WASHER ZINC 3/4"
34	NC02-07-0023	2	HEX. NUT ZINC 3/4-10
35	NC01-69-0786	1	GREASE FITTING 1/4-28 X 45
36	88-13-0005	1	CHAIN TENSIONER BUSHING

AGRIMETAL**SPIRAL DRIVE TRAIN GROUP**

CREATION : 28/05/19

REVISION : 23/12/25

ASSEMBLY : **88-57-0026**

AUTHOR : F.HÉLIE

#	PART #	Qty	TITLE
1	NC01-04-0109	6	CARR. BOLT GR2 ZINC 3/8-16 X 1"
2	NC02-14-0019	6	FLANGE NUT HEX. NC 3/8-16 GR. B
3	88-50-0120	1	SPIRAL CHAIN GUARD

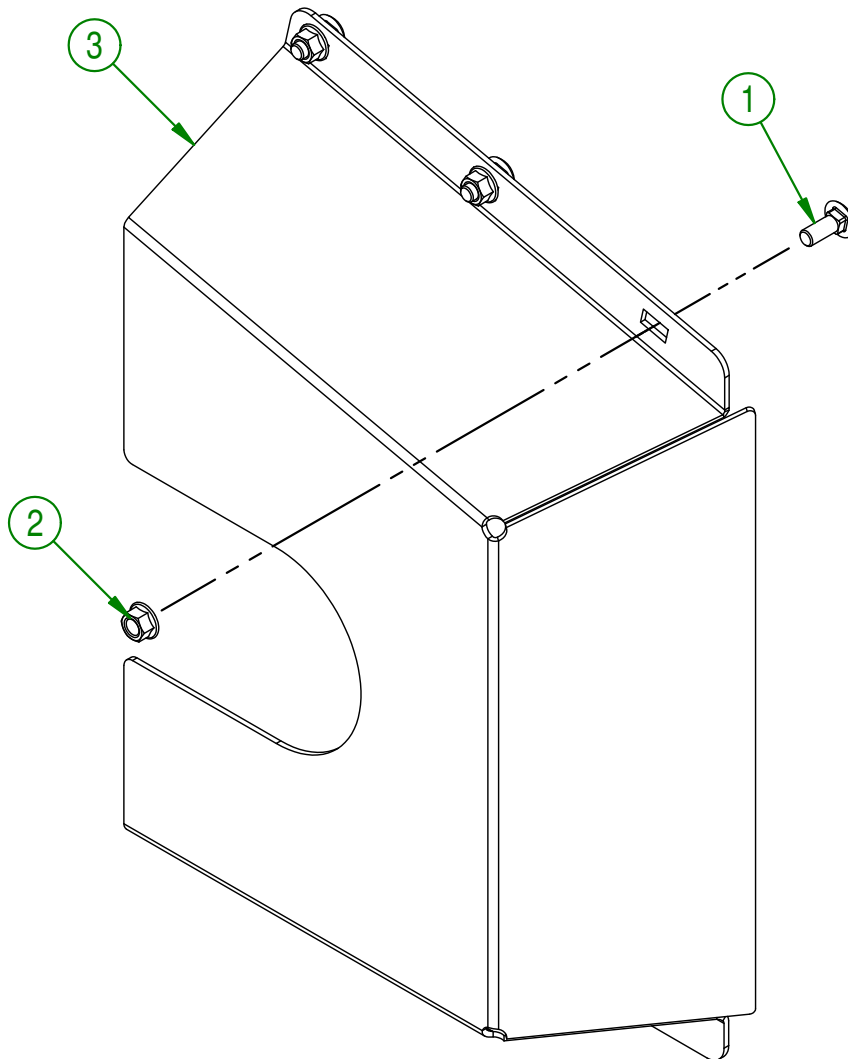
**AGRIMETAL****SPIRAL CHAIN GUARD GROUP**CREATION : 27/05/19
REVISION : 27/05/19ASSEMBLY : **88-57-0030**

AUTHOR : F.HÉLIE | Page 11 de 19

88-57-0006

#	PART #	Qty	TITLE
1	NC02-29-0028	2	PLASTIC WASHER 13/16" OD X 13/32" ID
2	NC01-17-0114	2	HEX. BOLT GR2 ZINC 3/8-16 X 1"
3	NC01-96-0011	2	NYLON NUT 3/8-16
4	NC02-26-1525	4	WASHER INOX .406" D.I. X .815" D.E.
5	88-57-0081	1	CHAIN GUARD

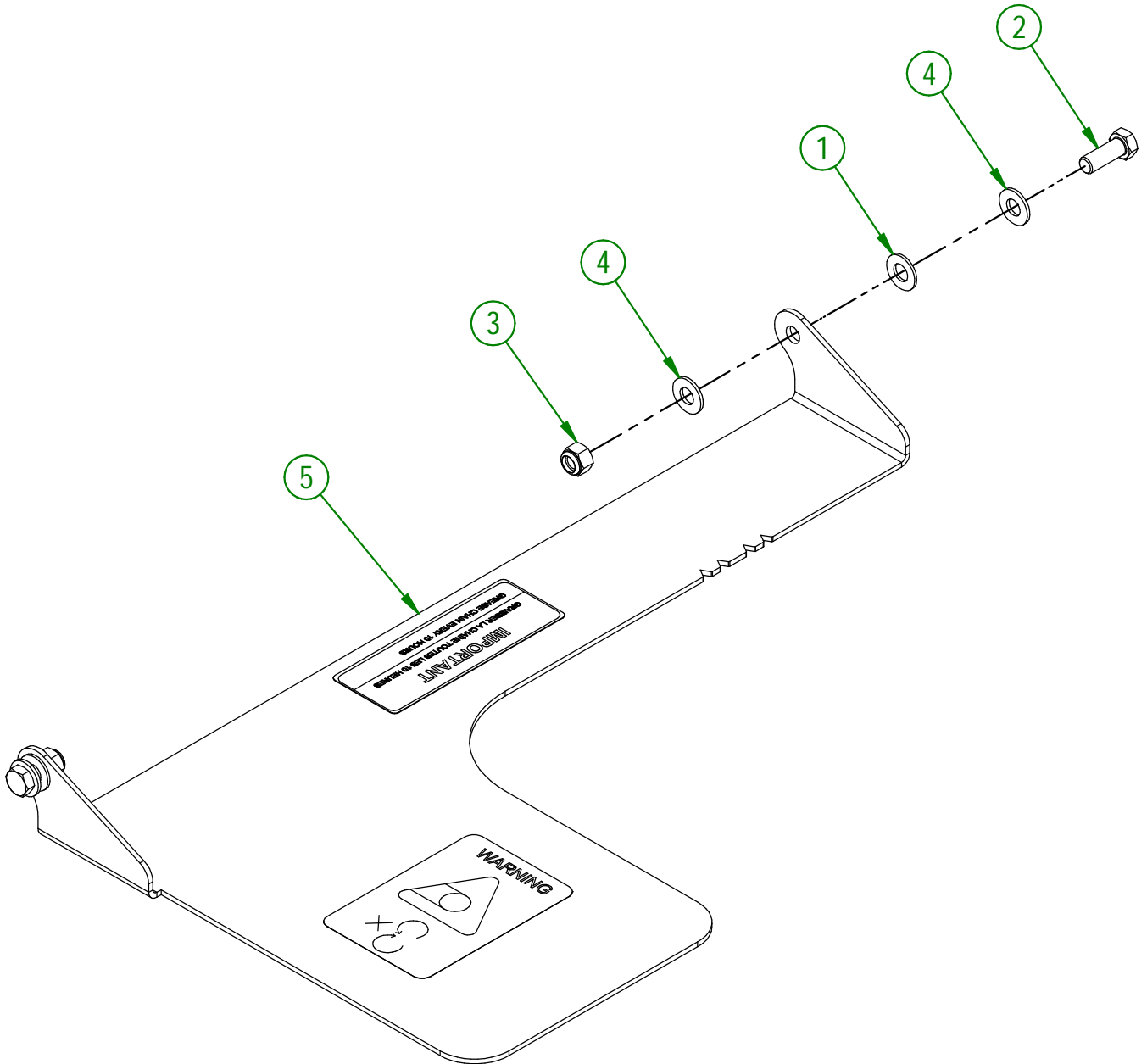

AGRIMETAL	
CHAIN GUARD GROUP	
CREATION : 27/05/19	ASSEMBLY : 88-57-0006
REVISION : 23/12/25	AUTHOR : F.HÉLIE

88-57-0010

#	PART #	Qty	TITLE
1	NC13-65-0003	1	BRASS ELBOW 90 3/8 FEM. NPT X 3/8 MALE NPT
2	83-34-0100	1	GEARBOX T279A
3	88-50-0010	1	GEARBOX ADJUSTMENT PLATE
4	NC02-22-0013	8	WASHER ZINC 5/8 ID X 1 1/2 OD
5	NC02-32-0016	8	LOCK WASHER ZINC 5/8"
6	NC01-17-0394	8	HEX. BOLT GR2 ZINC 5/8-11 X 1 1/2"
7	NC02-07-0020	16	HEX. NUT ZINC 1/2-13
8	83-55-0100	1	SPEED REDUCER 1000 TO 540 RPM
9	NC01-25-0265	6	HEX. BOLT GR5 ZINC 1/2-13 X 5 1/2"
10	01-01-0925	18	WASHER
11	NC02-32-0014	12	LOCK WASHER ZINC 1/2"
12	88-57-0040	1	PTO GUARD
13	NC01-63-0027	1	HAIRPIN COTTER
14	NC01-25-0249	4	HEX. BOLT GR5 ZINC 1/2-13 X 1 1/2" LG
15	NC13-25-0019	1	BLACK TIE RAP
16	NC13-50-0110	1	IMPORTANT/NOTICE PTO POSTER
17	88-50-0130	1	GEARBOX REDUCER SUPPORT
18	NC01-25-0251	2	HEX.BOLT GR5 NC ZINC 1/2-13 X 2"
19	88-41-0000	1	PTO GUARD STEEL CABLE
20	NC01-64-0005	2	OVAL SLEEVE (ALUMINUM)
21	88-34-0000	1	PTO DRIVE SHAFT IND-SNOW V90 1 3/4-20 X 1 3/4-20 SBIB

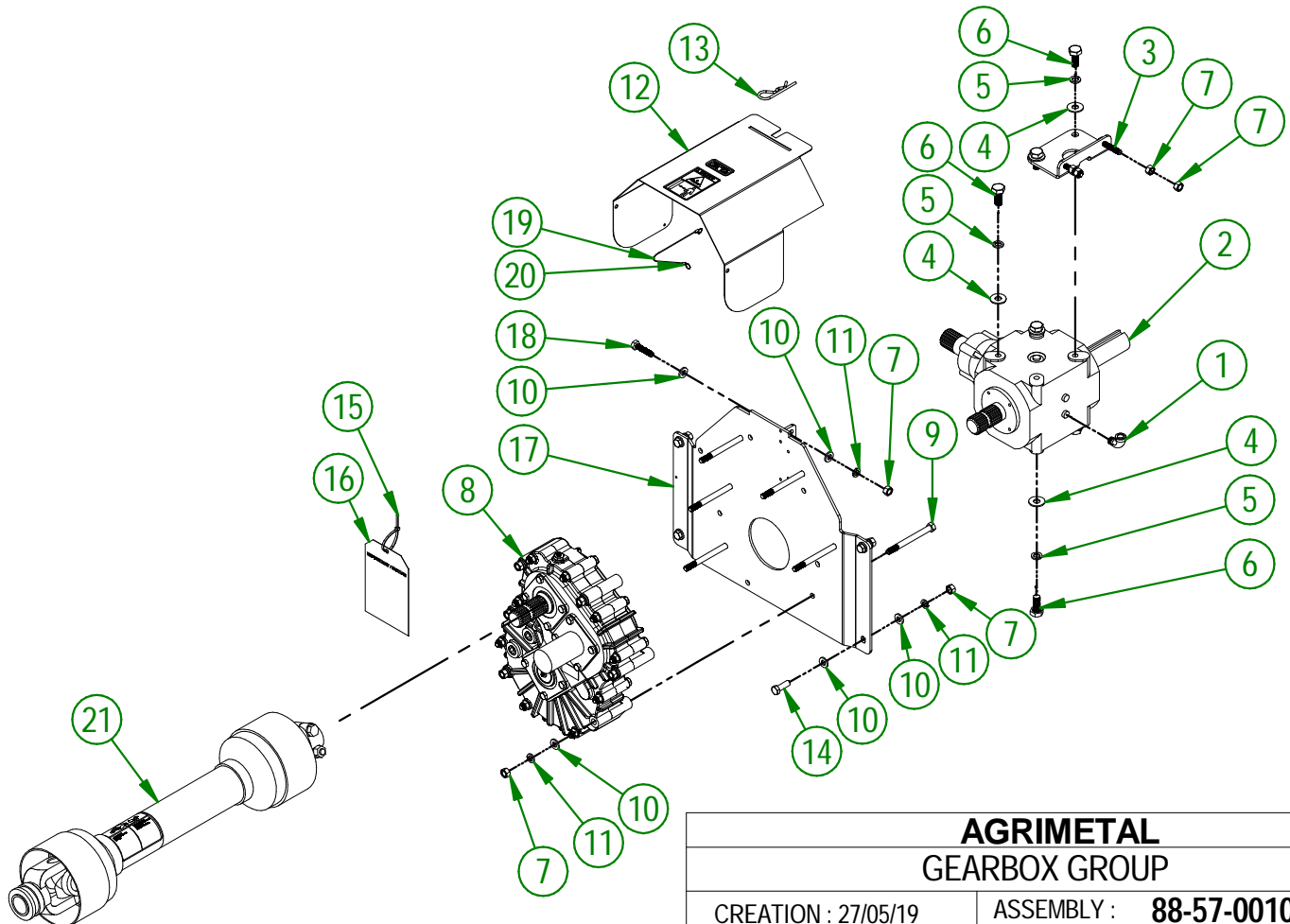

AGRIMETAL
GEARBOX GROUP

CREATION : 27/05/19
REVISION : 06/06/22

ASSEMBLY : **88-57-0010**
AUTHOR : F.HÉLIE

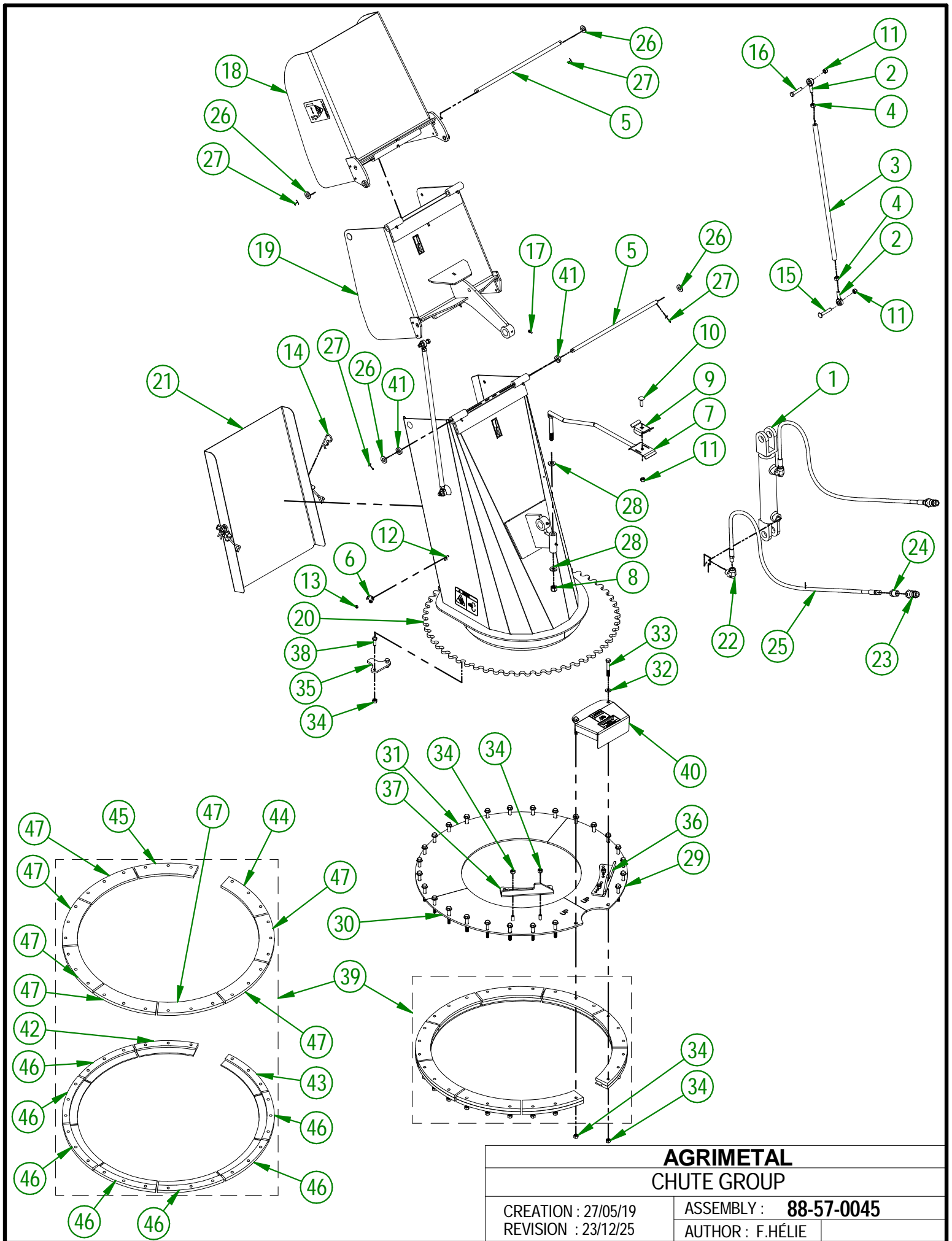

AGRIMETAL
CHUTE GROUP

CREATION : 27/05/19
REVISION : 23/12/25

ASSEMBLY : **88-57-0045**
AUTHOR : F.HÉLIE

88-57-0045

#	PART #	Qty	TITLE
1	NC13-45-0404	1	HYDRAULIC CYLINDER 6"
2	NC01-67-0304	4	ROD END 3/8-24
3	88-13-0030	2	CHUTE ROD
4	NC02-10-0018	4	NUT 3/8-24
5	88-20-0100	2	PIVOT
6	NC01-63-0052	2	ADJUSTABLE LATCH (STRIKE)
7	48-50-1030	1	HYDRAULIC HOSE SUPPORT
8	NC01-96-0014	1	NYLON-INSERT LOCKNUT ZINC 1/2-13
9	48-01-7530	1	HYDRAULIC HOSE SUPPORT
10	NC01-04-0110	1	CARR. BOLT GR2 ZINC 3/8-16 X 1 1/4"
11	NC01-96-0011	5	NYLON NUT 3/8-16
12	NC02-40-0080	4	MACHINE SCREWS SQUARE SOCKET #10-24 X 1/2" LG
13	NC01-96-0006	4	NYLON NUT ZINC 3/16
14	NC01-63-0026	2	COTTER PIN ZC 5/32" X 3"
15	NC01-07-0113	2	CARR. BOLT GR5 ZINC 3/8-16 X 2" LG
16	NC01-25-0117	2	HEX. BOLT GR5 ZINC 3/8-16 X 1 3/4" LG
17	NC01-69-0785	9	STRAIGHT GREASE FITTING 1/4-28
18	88-57-0085	1	CHUTE (TOP SECTION)
19	88-57-0090	1	CHUTE (MIDDLE SECTION)
20	88-57-0095	1	CHUTE (BOTTOM SECTION "STICKER INCLUDED)
21	88-57-0100	1	CHUTE DOOR
22	NC13-45-0038	2	ELBOW 90 3/8 FEM. NPT X 3/8 MALE NPT
23	NC13-45-0369	2	QUICK COUPLER 1/2-14 NPTF
24	NC13-45-0153	2	HEX. REDUCER 1/4 NPT X 1/2 NPT
25	NC17-02-0347	2	HYDRAULIC HOSE (111" LG)
26	NC02-25-0011	4	WASHER SAE ZINC 17/32 ID
27	NC01-69-0139	4	COTTER PIN ZINC 1/8" X 3/4"
28	NC02-25-0011	2	WASHER SAE ZINC 17/32 ID
29	88-50-0100	1	GUIDE CHUTE BRACE
30	88-50-0105	1	GUIDE CHUTE BRACE
31	88-50-0110	1	GUIDE CHUTE BRACE
32	NC02-26-1525	27	WASHER INOX .406" D.I. X .815" D.E.
33	NC01-17-0120	27	HEX.BOLT GR2 NC ZINC 3/8-16 X 2 1/2
34	NC01-93-0011	33	LOCK NUT 3/8-16
35	84-04-0170	1	STOPPER
36	88-04-0320	1	ADJUSTABLE STOPPER
37	88-04-0325	1	ADJUSTABLE STOPPER
38	NC01-17-0114	2	HEX. BOLT GR2 ZINC 3/8-16 X 1"
39	88-57-0110	1	GUIDE CHUTE GROUP
40	88-57-0115	1	SPROCKET GUARD GROUP
41	NC13-15-0334	2	PIVOT WASHER

88-57-0110

#	PART #	Qty	TITLE
42	49-42-0136	1	CHUTE GUIDE (UNDER)
43	49-42-0137	1	CHUTE GUIDE (UNDER)
44	49-42-0131	1	CHUTE GUIDE (TOP)
45	49-42-0132	1	CHUTE GUIDE (TOP)
46	49-42-0135	7	CHUTE GUIDE (UNDER)
47	49-42-0130	7	CHUTE GUIDE (TOP)

#	PART #	Qty	TITLE
1	48-01-7527	1	HYDRAULIC HOSE SUPPORT
2	48-50-1025	1	HYDRAULIC ENGINE SPROCKET
3	81-01-7600	1	HYDRAULIC HOSE SUPPORT
4	NC01-07-0111	1	CARR. BOLT GR5 ZINC 3/8-16 X 1 1/2"
5	NC01-17-0116	2	HEX. BOLT GR2 ZINC 3/8-16 X 1 1/2"
6	NC01-33-0113	4	HEX.BOLT GR8 ZINC 3/8-16 X 3/4"
7	NC01-45-0184	1	HEX. BOLT GR8.8 ZINC 8MM X 20MM
8	NC02-07-0018	3	HEX. NUT ZINC 3/8-16
9	NC02-26-0504	1	WASHER
10	NC02-26-1525	2	WASHER INOX .406" D.I. X .815" D.E.
11	NC02-32-0011	1	LOCK WASHER ZINC 5/16"
12	NC02-32-0012	7	LOCK WASHER ZINC 3/8"
13	NC02-44-0103	2	SET SCREW 5/16-18 X 3/8"
14	NC13-45-0014	2	QUICK COUPLER 1/2-14 NPTF
15	NC13-45-0153	2	HEX. REDUCER 1/4 NPT X 1/2 NPT
16	NC13-45-0367	2	45°-7/8-14 MALE O RING X 1/2 FEM.TOUR.NPT PT
17	NC14-45-0156	1	HYDRAULIC MOTOR
18	NC17-02-0329	2	HYDRAULIC HOSE (63" LG)
19	NC17-46-0031	1	HYDRAULIC MOTOR BUSHING

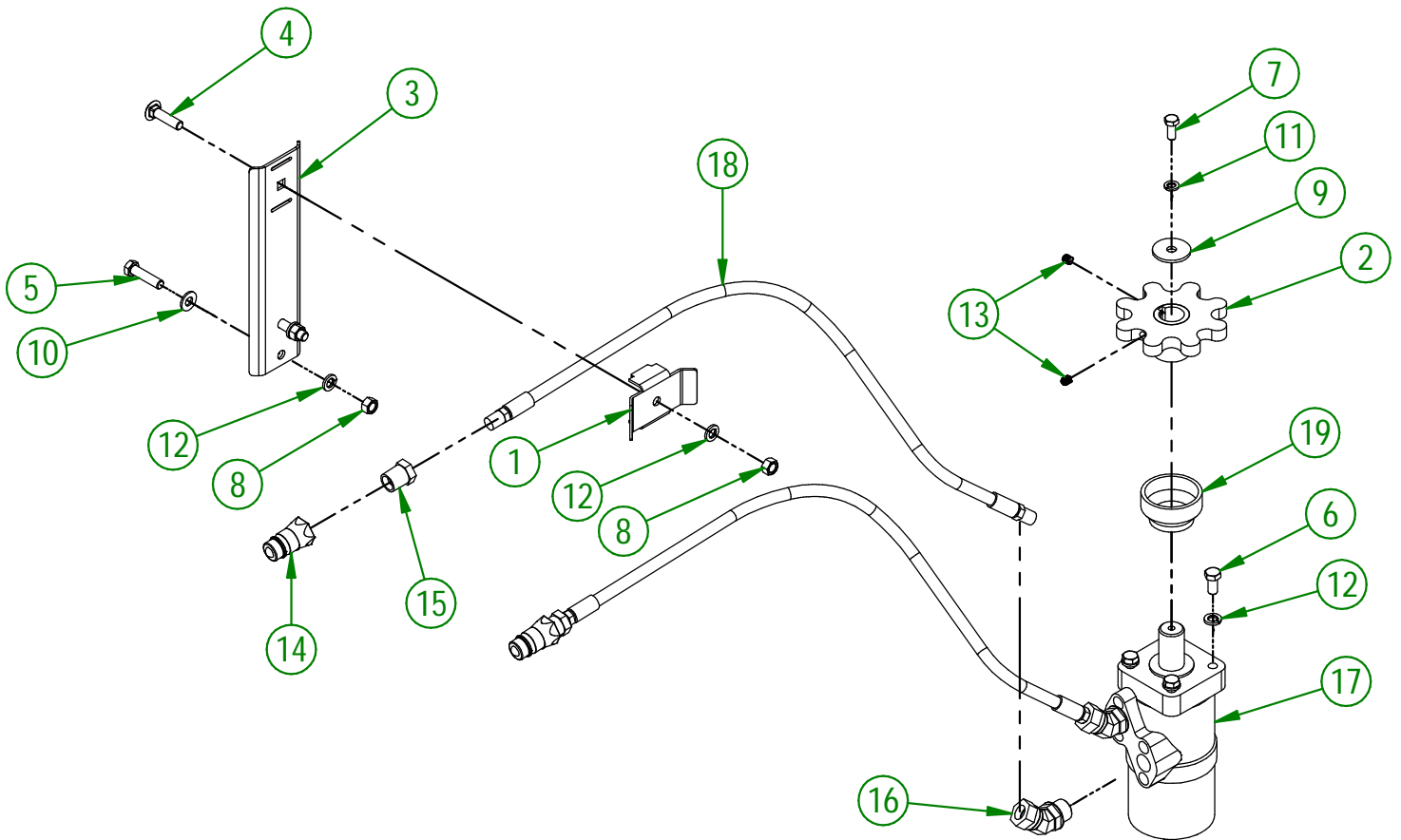

AGRIMETAL
HYDRAULIC MOTOR GROUP

CREATION : 27/05/19
 REVISION : 25/03/26

ASSEMBLY : **88-57-0020**
 AUTHOR : F.HÉLIE

#	PART #	Qty	TITLE
1	NC13-30-0237	1	PLASTIC TUBE FOR OPERATOR'S MANUAL
2	NC02-25-0007	2	WASHER ZINC 0.281 = 9/32
3	NC01-96-0009	2	NYLON-INSERT LOCKNUT ZINC 1/4-20
4	NC01-17-0008	2	HEX. BOLT GR2 ZINC 1/4-20 X 1 1/2"
5	81-98-0531	1	FRENCH OPERATOR'S MANUAL (MS28 & 30)

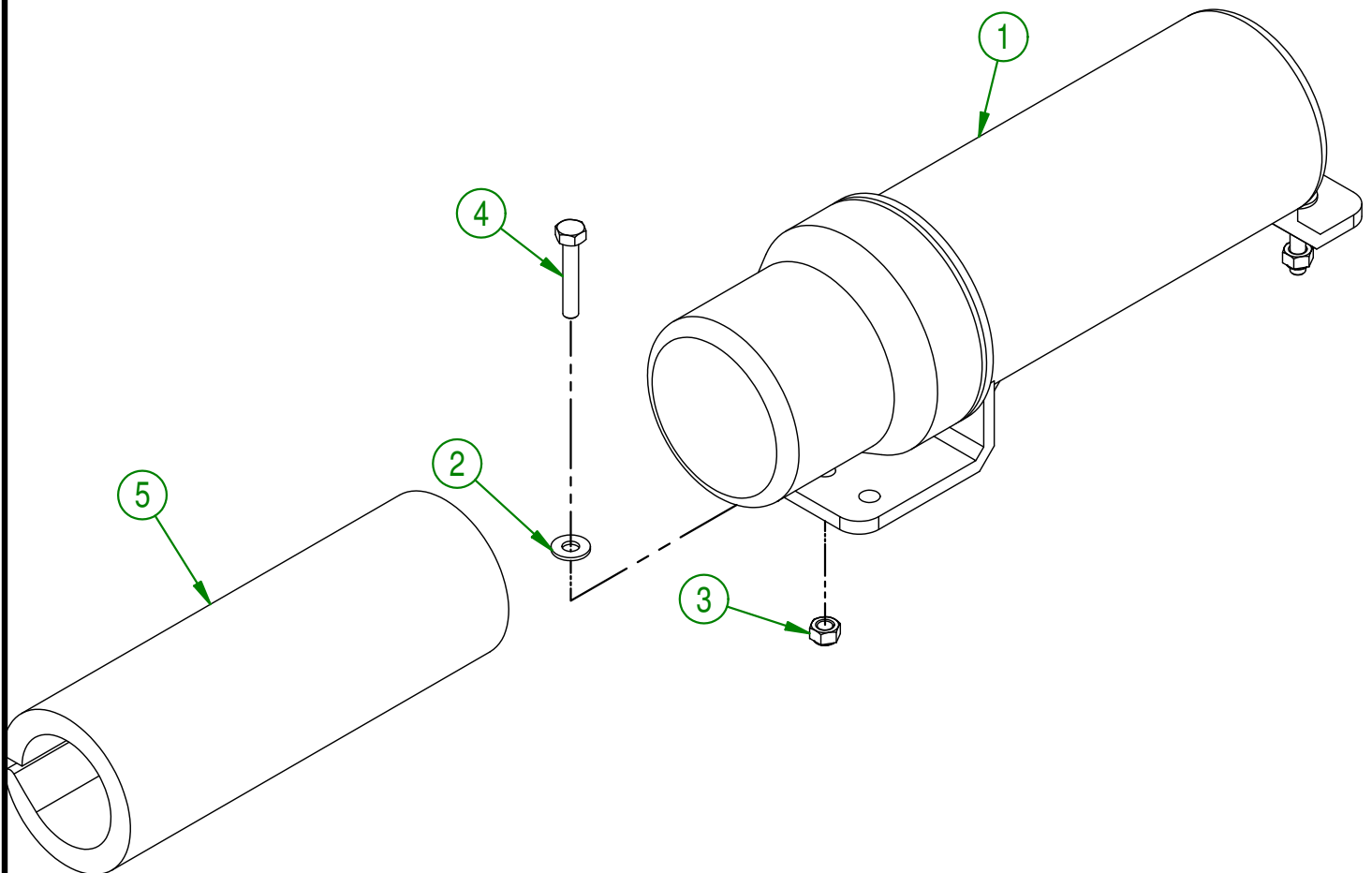
**AGRIMETAL****OPERATOR'S MANUAL TUBE GROUP**

CREATION : 27/05/19
 REVISION : 26/08/19

ASSEMBLY : **88-57-0061**

AUTHOR : F.HÉLIE | Page 17 de 19

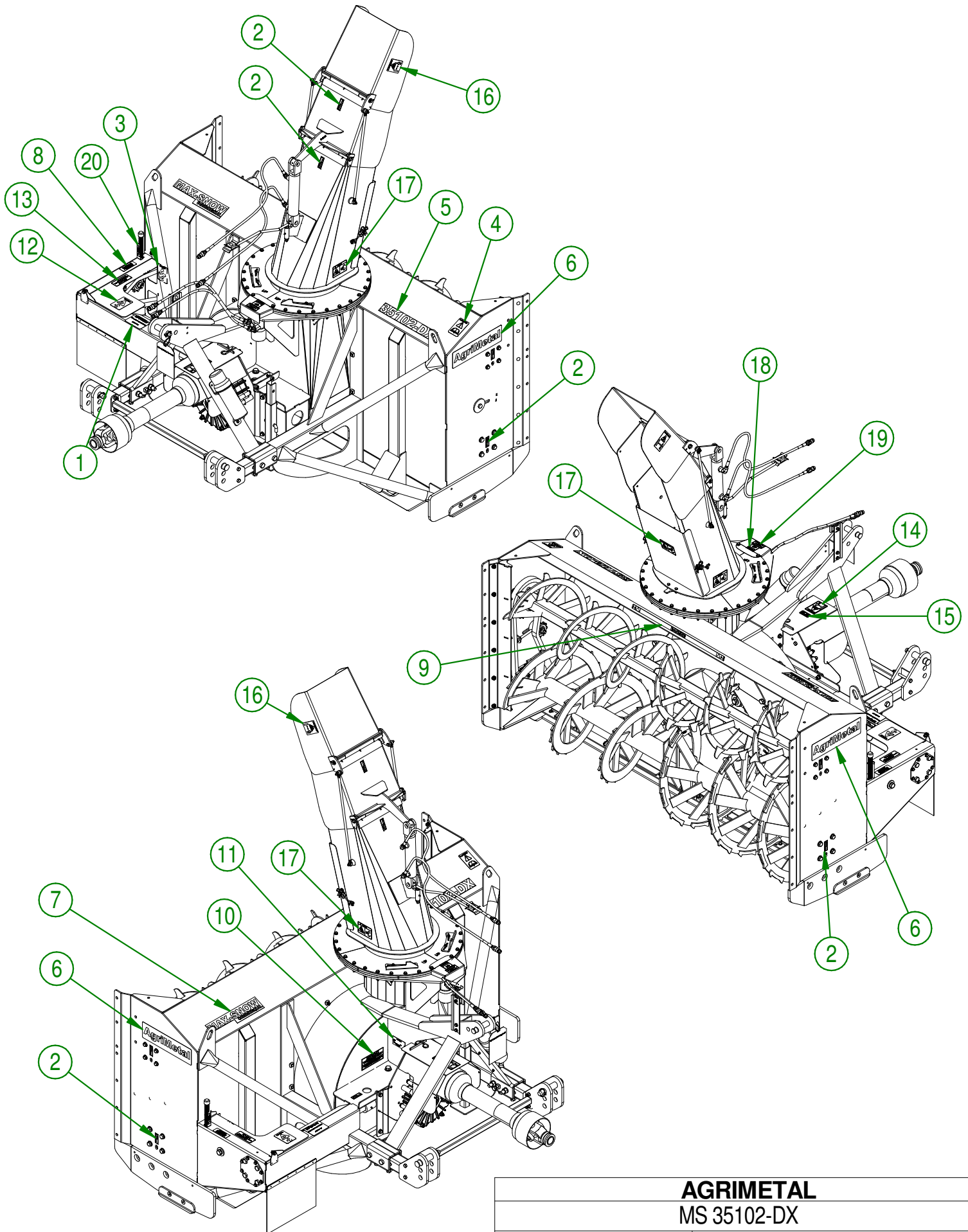

AGRIMETAL
MS 35102-DX

CREATION : 28/05/19
 REVISION : 24/11/21

ASSEMBLY : **88-99-0001**
 AUTHOR : F.HÉLIE

88-99-0001

#	PART #	QTY	TITLE
1	NC13-33-0281	1	STICKER SHEAR BOLT
2	NC13-33-0024	8	STICKER GREASE HERE
3	NC13-33-0189	1	STICKER DANGER (PERSON AND CHAIN DRIVE)
4	NC13-33-0183	1	STICKER CAUTION OPERATION MANUAL
5	NC13-33-0331	1	STICKER 30102
6	NC13-33-0001	2	STICKER AGRIMETAL
7	NC13-33-0241	1	STICKER MAX-SNOW COMMERCIAL
8	NC13-33-0248	1	STICKER IMPORTANT 4 1/4 INCHES 110mm
9	NC13-33-0274	1	STICKER DANGER
10	NC13-33-0317	1	STICKER GREASE DRIVE LINE TELESCOPIC SHAFT
11	NC13-50-0086	1	SERIAL NUMBER PLATE
12	NC13-33-0283	1	STICKER DANGER (PERSON AND CHAIN DRIVE)
13	NC13-33-0343	1	GREASE CHAIN EVERY 10 HOURS STICKER
14	NC13-33-0187	1	STICKER DANGER (PTO AND PERSON)
15	NC13-33-0228	1	STICKER MAXIMUM 1000 RPM
16	NC13-33-0192	2	STICKER (PROJECTION RISK)
17	NC13-33-0249	3	STICKER DANGER
18	NC13-33-0326	1	STICKER DANGER (HAND)
19	NC13-33-0327	1	STICKER END ROTATION ADJUSTMENT
20	NC13-33-0344	1	ADJUSTEMENT INDICATOR STICKER

AGRIMETAL**MS 35102-DX**

CREATION : 28/05/19

REVISION : 24/11/21

ASSEMBLY : **88-99-0001**

AUTHOR : F.HÉLIE